

SW991WZ50

Wireless PTAC Thermostat

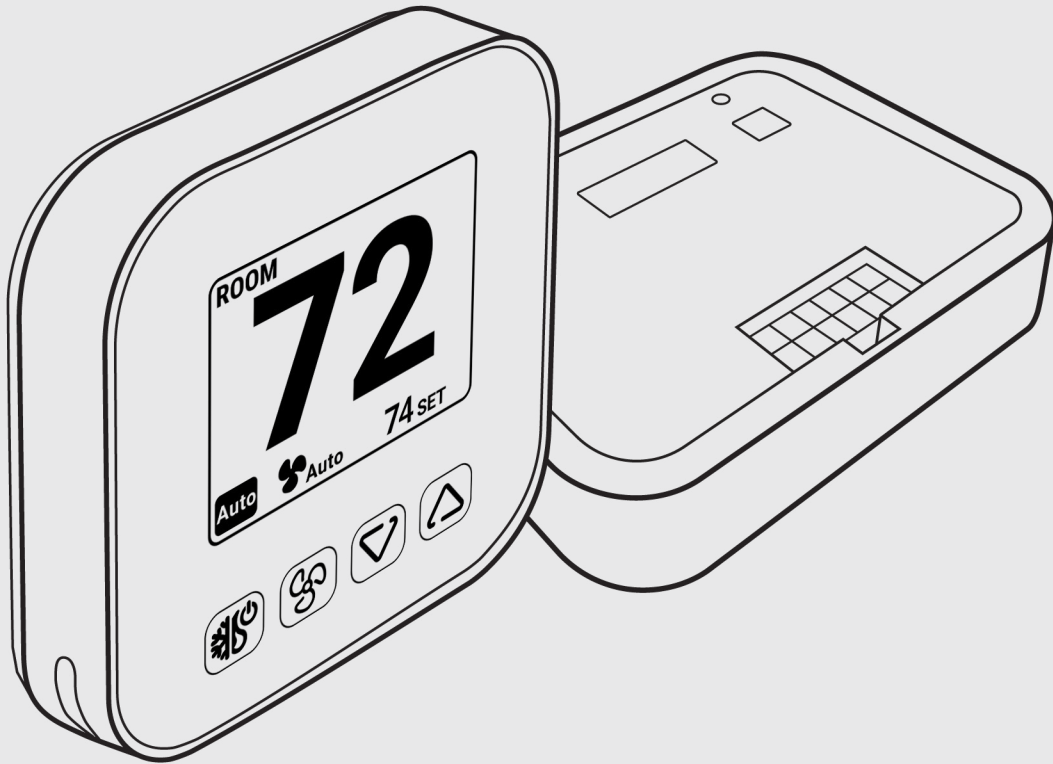

User Manual

Table of Contents

Important Safety Instructions	3
FCC and IC Regulatory Statements	4
Battery Warning	5
Installation and Wiring	
Important Things to Know Before Installation	6
In the Box	7
Required but Not Supplied	7
Thermostat and Controller Layouts	8
Specifications	9
Installation and Wiring Processes	13
Configuration	
About the EC Tool Pro App	18
Create Your First Profile	19
Manage Properties and Profiles	25
Install a Saved Profile	29
Download a Thermostat's Profile	32
View Thermostat's Profile	33
Error Messages and Troubleshooting	34
Engineering Menus	42
Configuration via the Thermostat Menu	45
Power Outages	46
Restore Factory Defaults	46
Operation	
Wake up Screen	47
Schedule	48
Filter Change Reminder	48
Set HVAC Mode	48
Set Fan Mode	49
Switch Temperature Unit Between °F and °C	50
Adjust Set Temperature	50
Restore Profile Defaults	51
Maintenance	51

Support

HD Supply is here to help.

Online Chat
hdsupplysolutions.com

Email
customercare@hdsupply.com

Call
 1-800-431-3000

HDPRO USN #
 334676860

HDS Part #
 364604

Important Safety Instructions

SAVE THESE INSTRUCTIONS

The applied nameplate is located at the bottom or rear of the product.

When using your thermostat equipment, basic safety precautions should always be followed to reduce the risk of fire, electric shock and injury, including the following:

1. This product should be installed by a qualified technician.
2. Read and understand all instructions.
3. Follow all warnings and instructions marked on the product.
4. Do not use liquid or aerosol cleaners. Use a damp cloth for cleaning.
5. Do not expose the product to liquid or install this in wet areas such as bathroom, near a sink, near a swimming pool, or in a damp basement.
6. Do not install this product on an unstable surface.
7. This product should not be installed near or over a radiator or heat register, or in any area where proper ventilation is not provided.
8. This product should be operated only from the type of power source indicated on the marking label.
9. To reduce the risk of electric shock, do not disassemble this product. Opening or removing parts of the thermostat may expose you to dangerous voltages or other risks. Incorrect reassembling can cause electric shock.
10. Remove this product and refer servicing to an authorized service facility under the following conditions:
 - a. If liquid has spilled onto the product.
 - b. If the product has exposed to rain or water.
 - c. If the product does not operate normally by following the operating instructions. Adjust only the controls that are covered by the operating instructions.
 - d. If the product has been dropped resulting in physical damage.
 - e. If the product exhibits a distinct change in performance.
11. Avoid using the thermostat during an electrical storm. There is a remote risk of electric shock.
12. The thermostat should be mounted at a height of less than 6 feet.

CAUTION:

- Keep small metallic objects such as pins and staples away from the thermostat.
- Do not mix old and new batteries and Do not mix alkaline, standard (carbon-zinc) or rechargeable (ni-cad, ni-mh, etc.) batteries.
- Avoid using the battery in the following conditions:
 - High or low extreme temperature during use, storage or transportation.
 - Replacement of a battery with an incorrect type that can defeat a safeguard.
 - Disposal of a battery into fire or a hot oven, or mechanically crushing or cutting of a battery can result in an explosion.
 - Leaving a battery in an extremely high temperature surrounding environment that can result in an explosion or the leakage of flammable liquid or gas.
 - Extremely high temperature and/or extremely low air pressure that can result in an explosion or the leakage of flammable liquid or gas.
- Use 18~24 AWG only.
- For supply connections, use wires rated for 167°F (75°C) minimum.

FCC and IC Regulatory Statements

FCC Compliance Statement

This device complies with Part 15 of the FCC Rules. Operation is subject to the following two conditions: (1) this device may not cause harmful interference, and (2) this device must accept any interference received, including interference that may cause undesired operation.

Warning: Changes or modifications to this unit not expressly approved by the manufacturer could void the user's authority to operate the equipment.

NOTE: This equipment has been tested and found to comply with the limits for a Class B digital device, pursuant to Part 15 of the FCC Rules. These limits are designed to provide reasonable protection against harmful interference in a residential installation. This equipment generates, uses, and can radiate radio frequency energy and, if not installed and used in accordance with the instructions, may cause harmful interference to radio communications. However, there is no guarantee that interference will not occur in a particular installation. If this equipment does cause harmful interference to radio or television reception, which can be determined by turning the equipment off and on, the user is encouraged to try to correct the interference by one or more of the following measures:

- Reorient or relocate the receiving antenna.
- Increase the separation between the equipment and receiver.
- Connect the equipment into an outlet on a circuit different from that to which the receiver is connected.
- Consult the dealer or an experienced radio/TV technician for help.

RF Exposure Information

This equipment complies with FCC radiation exposure limits set forth for an uncontrolled environment. In order to avoid the possibility of exceeding the FCC radio frequency exposure limits, human proximity to the antenna shall not be less than 20cm during normal operation.

ISED Warning

This device complies with Innovation, Science, and Economic Development Canada license exempt RSS standard(s). Operation is subject to the following two conditions:

1. this device may not cause interference.
2. this device must accept any interference, including interference that may cause undesired operation of the device.

Operation in the band 5150–5250 MHz is only for indoor use to reduce the potential for harmful interference to co-channel mobile satellite systems.

⚠ WARNING

- **INGESTION HAZARD:** This product contains a button cell or coin battery. **DEATH** or serious injury can occur if ingested.
- A swallowed button cell or coin battery can cause **Internal Chemical Burns** in as little as **2 hours**.
- **KEEP** new and used batteries **OUT OF REACH of CHILDREN**.
- **Seek immediate medical attention** if a battery is suspected to be swallowed or inserted inside any part of the body.
- The product contains **Non-replaceable batteries**.
Compatible battery type: CR1220
Nominal battery voltage: 3V



ⓘ Cautions

- The factory installed clock backup battery is not replaceable and rechargeable. There may be a risk of explosion if a wrong type of clock backup battery is used. Use only the factory installed non-replaceable battery (Compatible battery type CR1220, Nominal battery voltage 3V) and do NOT recharge the battery.
- Even used batteries may cause severe injury or death.
- Do not force discharge, recharge, disassemble, heat above 212°F (100°C) or incinerate. Doing so may result in injury due to venting, leakage or explosion resulting in chemical burns.
- Call a local poison control center for treatment information.
- Remove and immediately recycle or dispose of used batteries according to local regulations and keep away from children. Do NOT dispose of batteries in household trash or incinerate.
- Battery must be removed from the thermostat before it is scrapped.
- Thermostat must be disconnected from the supply mains when removing the battery.
- Battery is to be disposed of safely.

Installation and Wiring

Important Things to Know Before Installation

- This product should be installed by a qualified technician.
- Carefully read these instructions. You could damage this product or cause a hazardous condition if you fail to follow these instructions.
- Electrical Hazard Caution: Turn OFF power to your HVAC system before installation. Failure to disconnect the power before beginning to install this product can cause electrical shock or equipment damage.
- Do not over-tighten the screws during mounting.

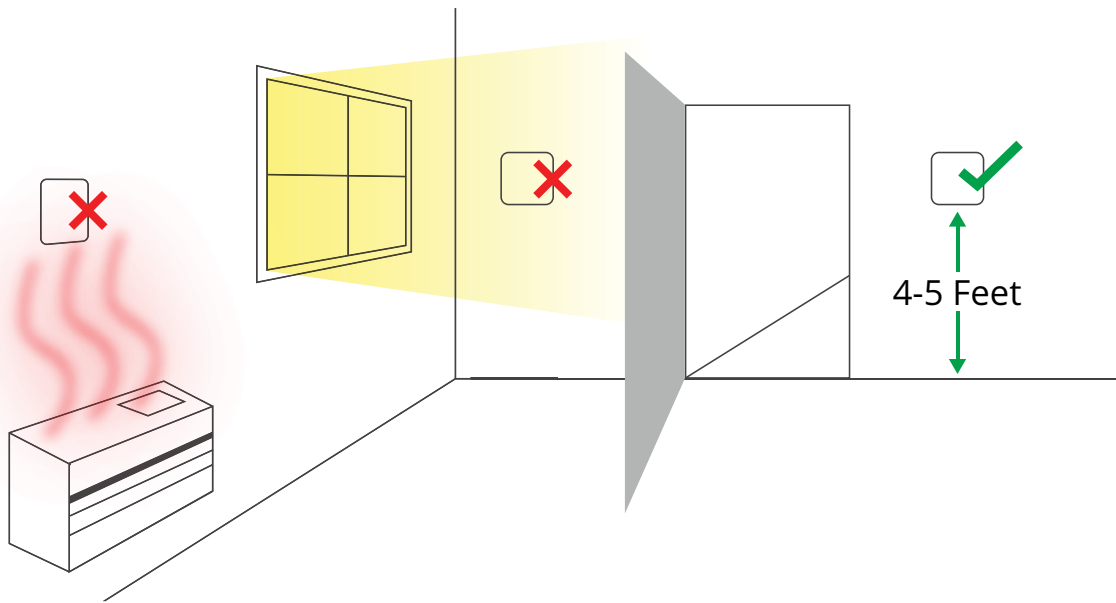

The thermostat **should be mounted:**

- Approximately 4 - 5 feet above the floor
- In a central location with average temperature and humidity
- On an interior wall that is easily accessible
- In a location with good air circulation

The thermostat **should not be mounted:**

- Where it is exposed to direct sunlight
- To a wall that contains concealed chimneys or pipes
- Where there is obstructed air flow such as in corners or behind doors
- Directly above or below an hot or cold air ducts
- On an exterior wall

In the Box



Thermostat

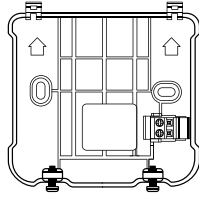

Wall Plate



AA Batteries x3

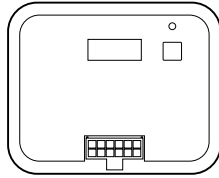

Controller

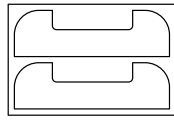

Double-sided Tape

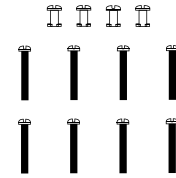

T-Locks & Junction
Box Screws

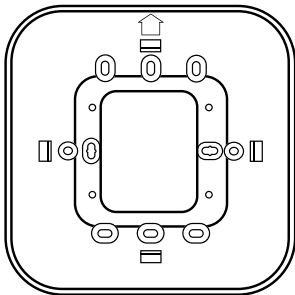

Universal Deco Plate

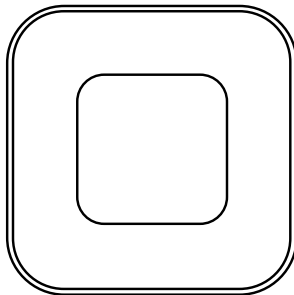

Deco Plate Cover

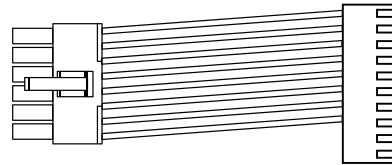

Wire Harness

Required but Not Supplied

- Screwdriver set
- Drill and drill bits; 3/16" for drywall and 7/32" for plaster
- Pencil
- Level

Device Required for App

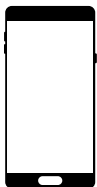

Smartphone with Bluetooth® feature

- iOS 15 or higher
- Android 12.0 or higher

Thermostat and Controller Layouts

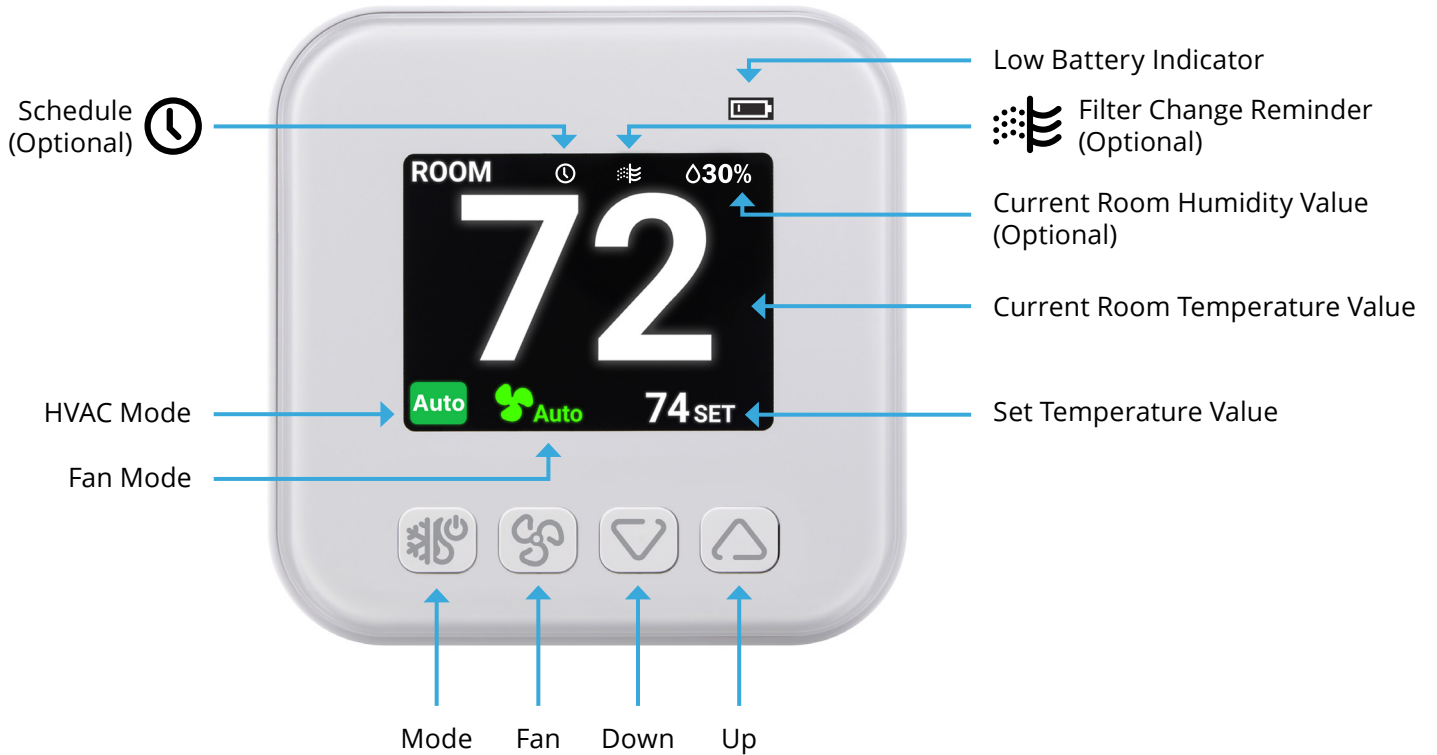

Note

Only when the humidity, schedule, and filter change reminder features are enabled via the EC Tool Pro app, can the current room humidity, schedule, and filter change reminder be displayed on the screen.

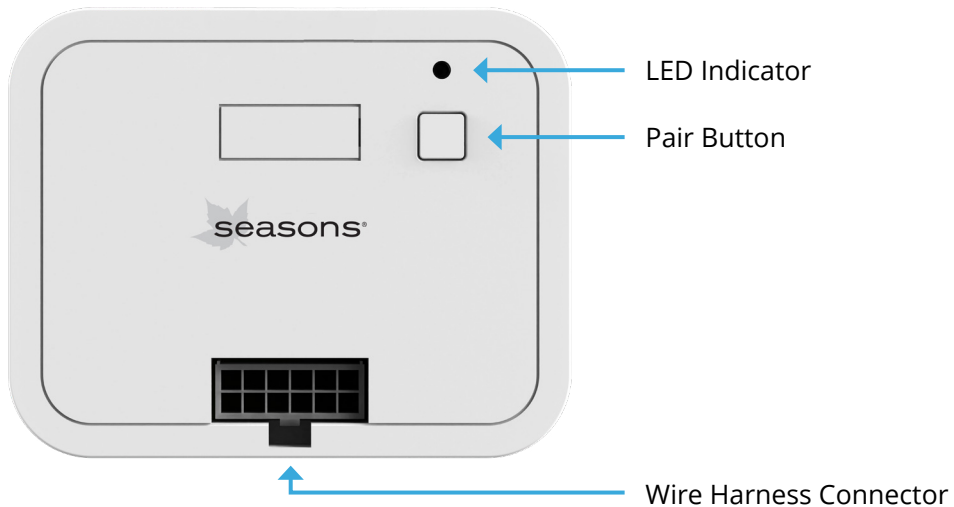

Specifications

	Thermostat	Controller
Product Dimensions	3.9" x 3.9" x 1" (9.9cm x 9.9cm x 2.6cm)	3.94" x 3.15" x 0.94" (10cm x 8cm x 2.4cm)
Mounting Type	Surface Mount, Junction Box*	Double-sided Tape
HVAC Systems	Seasons PTACs - Conventional or Heat Pump with Aux Heat	Seasons PTACs - Conventional or Heat Pump with Aux Heat
Power Requirement	Either 3 x AA battery or 24V AC (60Hz 0.5A with "C" common wire)	Input: 24V AC 60Hz 3.0A with "C" common wire Output: 3.0A Max @ 24V AC
Battery Life	12 months	—
Display	2.8" TFT (240 x 320, RGB)	—
Display Back Light	Configurable - Dimming or Off	—
Display Brightness	3 Levels	—
Number of Buttons	4 Hard Buttons	1, Pair Button
LED Indicator	1, Red Color	1, Dual Color
HVAC System Modes	Auto, Cool, Heat, and Off	—
Fan Modes	2 Fan Speeds Settings: Auto, Low, High, and Off	—
Temperature Set Range	49°F-89°F / 9.5°C-31.5°C	—
Room Temperature Display Range	32°F-122°F / 0°C-50°C (If the real room temperature drops below 0°C or rises above 50°C, the thermostat screen will still show 0°C or 50°C.)	—

* A universal deco plate kit is required for junction box mounting.

Specifications

	Thermostat	Controller
Room Humidity Display Range	0%-95% RH (If the real room humidity drops below 0% or rises above 95%, the thermostat screen will still show 0% or 95%.)	—
Terminal Connections	C, R	Wire harness for 10-pin mode B connection
Max Stage Supported	PTAC: Conventional 1H1C 2 Speed Fan PTAC: Heat Pump 2H1C 2 Speed Fan	PTAC: Conventional 1H1C 2 Speed Fan PTAC: Heat Pump 2H1C 2 Speed Fan
Recommended Wire	18 Gauge (Solid) - max. length: 40 m 24 Gauge (Solid) - max. length: 11 m	18 Gauge (Solid) - max. length: 40 m 24 Gauge (Solid) - max. length: 11 m
Disconnection Type	—	1.B
Rated Impulse Voltage	—	800V
Pollution Degree	—	2
Automation Cycle	—	50,000

Caractéristiques

	Thermostat	Controller
Dimensions du produit	9,9 cm x 9,9 cm x 2,6 cm (3,9" x 3,9" x 1")	10 cm x 8 cm x 2,4 cm (3,94" x 3,15" x 0,94")
Type de montage	Montage en surface, boîte de jonction*	Ruban adhésif double face
Systèmes CVC	Climatiseurs de piscine Seasons - Pompes à chaleur conventionnelles ou avec chauffage auxiliaire	Climatiseurs de piscine Seasons - Pompes à chaleur conventionnelles ou avec chauffage auxiliaire
Besoin en énergie	Soit 3 piles AA ou 24 V CA (60 Hz 0,5 A avec fil commun « C »)	Entrée : 24 V CA 60 Hz 3,0 A avec fil commun « C » Sortie : 3,0 A max à 24 V CA
Autonomie de la batterie	12 mois	—
Afficher	Écran TFT 2,8" (240 x 320, RVB)	—
Rétroéclairage de l'écran	Configurable - Atténuation ou arrêt	—
Luminosité de l'écran	3 niveaux	—
Nombre de boutons	4 boutons durs	1, bouton Pair
Indicateur LED	1, couleur rouge	1, double couleur
Modes du système CVC	Auto, refroidissement, chauffage et arrêt	—
Modes de ventilation	2 réglages de vitesse du ventilateur : Auto, Faible, Élevé et Arrêt	—
Plage de réglage de la température	49°F-89°F / 9,5°C-31,5°C	—
Température ambiante Plage d'affichage	32°F-122°F / 0°C-50°C (Si la température réelle de la pièce descend en dessous de 0°C ou monte au-dessus de 50°C, l'écran du thermostat affichera toujours 0°C ou 50°C.)	—

* Un kit de plaque décorative universelle est requis pour le montage de la boîte de jonction. 9

Caractéristiques

	Thermostat	Contrôleur
Affichage de l'humidité ambiante Gamme	0%-95% HR (si l'humidité réelle de la pièce descend en dessous de 0% ou monte au-dessus de 95%, l'écran du thermostat affichera toujours 0% ou 95%.)	—
Connexions des terminaux	C, R	Faisceau de câbles pour connexion mode B à 10 broches
Niveau maximal pris en charge	PTAC : Ventilateur conventionnel 1H1C à 2 vitesses PTAC : Pompe à chaleur 2H1C à 2 vitesses	PTAC : Ventilateur conventionnel 1H1C à 2 vitesses PTAC : Pompe à chaleur 2H1C à 2 vitesses
Fil recommandé	Calibre 18 (solide) - longueur max. : 40 m Calibre 24 (solide) - longueur max. : 11 m	Calibre 18 (solide) - longueur max. : 40 m Calibre 24 (solide) - longueur max. : 11 m
Type de déconnexion	—	1.B
Tension d'impulsion nominale	—	800V
Degré de pollution	—	2
Cycle d'automatisation	—	50,000

Installation and Wiring Processes

1. Power off your PTAC

Disconnecting the power protects you and avoids damage. After disconnecting, adjust the set temperature to confirm the system is off.

2. Verify system compatibility

The SW991WZ50 wireless thermostat includes a wire harness that connects directly to the Seasons PTAC's Mode B 10-pin connector. If your Seasons PTAC supports a legacy Mode A, wired thermostat connection (individual screw type wire terminals), then you will need to cut the 10-pin connector and secure the individual control wires to the wired thermostat terminals using a precision screw driver.

CAUTION: The SW991WZ50 is compatible with low-voltage (24V), single transformer systems only. If you inspect and find any of the following, then this thermostat is not compatible with your system.

1. Labels on the wiring or old thermostat warning of High Voltage, 120V, or 240V connections.
2. Thick electrical wires that are connected using wire nuts.
3. Your old thermostat supports RC and RH terminals that are wired separately (not connected via jumper wire).

If you have any enquiries about system compatibility, email: customercare@hdsupply.com

3. Confirm that your PTAC is set/configured to be controlled by a wired wall thermostat

When adding this thermostat to a Seasons branded PTAC, confirm that the PTAC's Dip Switches are in the correct position. This thermostat requires switch S3 to be in the Up/On position and S9 to be in the Down/Off position to function properly.

Note: The Dip Switch labels are located on the PCB, just below the switch assembly.

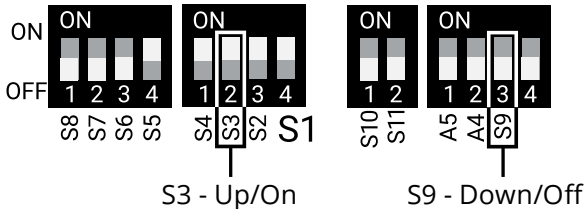

Installation and Wiring Processes

4. Controller Mounting and Wiring

Depending on your Seasons PTAC model, follow one of the two wiring modes described below.

Mode A

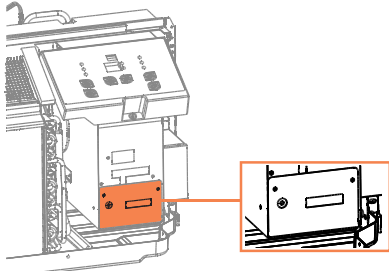

Mode B

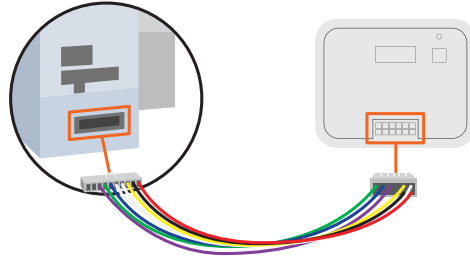

Terminal	Designation	Wire Color
FC (L)	Front Desk Control Terminal L	
FC (N)	Front Desk Control Terminal N	
LOW-FAN	Low-Fan Speed	Purple
HI-FAN	High-Fan Speed	Green
4-WAY	4-Way Valve; Reverse Cycle (Energized in Heat) for Heat Pump Models	Blue
HEAT2	Electrical Heater 2	White
HEAT1	Electrical Heater 1	White
COMP	Compressor	Yellow
24V (N)	24VAC Terminal N (Neutral), Common	Black
24V (L)	24VAC Terminal L	Red

Installation and Wiring Processes

4. Controller Mounting and Wiring

- Attach the controller behind the front grill of the PTAC and secure it with the supplied double-sided tape.
- Cover/protect any unused or loose wire leads. Route the wires so they do not sag into the condensation pan.

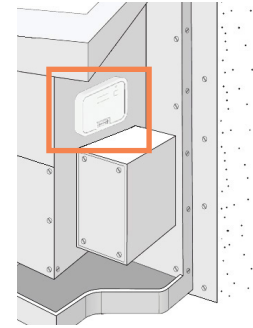

Note

The thermostat can be mounted up to 200 feet away from the controller with no obstructions, or 100 feet away with standard building materials in between.

5. Attach the wall plate

Wall Plate Mounting Option 1: Direct Wall Mounting

Hold the wall plate up to the wall where you want the thermostat to be mounted. Make sure that the wire bundle aligns near the center of the wall plate. Verify the plate is level with a bubble level, then mark the screw positions through the screw holes in the wall plate.

Using your marks as reference, drill 2 holes and install the provided wall anchors. If you will be using c-wire or 24vac adapter to power the thermostat, route the wires through the opening in the center of the wall plate, then secure it to the wall with the provided screws. The slots in the wall plate will help to compensate for any minor misalignment.

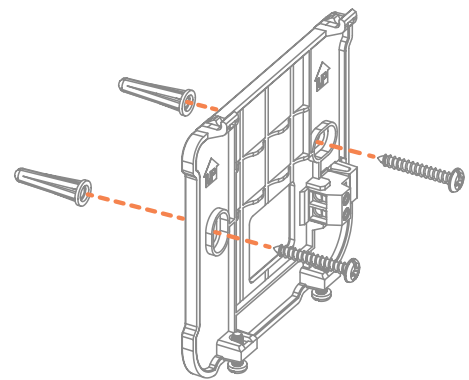

Wall Plate Mounting Option 2: Direct Wall Mounting with Deco Plate Kit

Hold the deco plate up to the wall where you want the thermostat to be mounted. Make sure that the wire bundle aligns near the center of the deco plate. Verify the plate is level with a bubble level, then mark the screw positions through the screw holes in the deco plate.

1. Push the cover towards the deco plate until it clicks into place.
2. Using your marks as reference, drill 2 holes and install the provided wall anchors. Route the wires through the opening in the center of the deco plate, then the wall plate.
3. Align the screw holes and secure them to the wall with the provided screws. The slots in the wall plate will help to compensate for any minor misalignment.

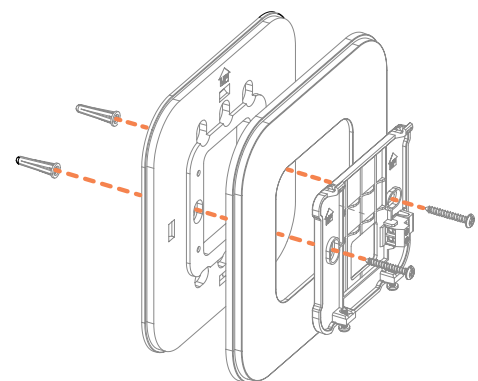

Installation and Wiring Processes

Wall Plate Mounting Option 3: Junction Box Mounting with Deco Plate Kit

1. Attach the deco plate to the junction box with the provided junction box screws.
2. Push the cover towards the deco plate until it clicks into place.
3. Attach the wall plate to the deco plate with the provided T locks.
4. Route the wires in the junction box through the openings in the centers of the deco plate and the wall plate.

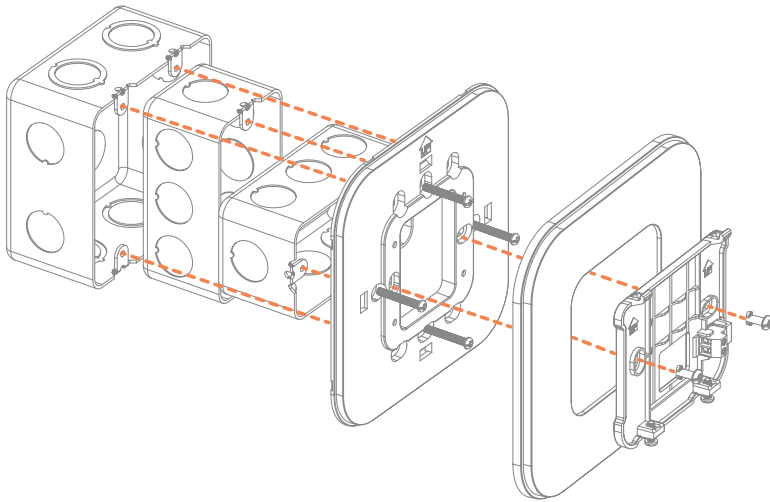

6. Install thermostat batteries or connect wall plate power wires

Battery powered application: Install 3 x AA batteries into the rear housing of the thermostat.

C-Wire/24VAC supply application: Route the 24V C (common) and R (load) wires through the center of the wall plate. Using a precision screw driver, connect the wires to the C and R terminals. Once connected, press down on the wires to ensure they are flush with the wall plate. Once wires are securely connected, press the wires down to ensure they are flush with the wall plate.

7. Attach the thermostat

Swing the thermostat into position by engaging the lugs at the top of the wall plate before pushing it carefully home into its plug-in terminal block.

Lock the thermostat into place by tightening the 2 Phillips screws located on the bottom edge of the thermostat.

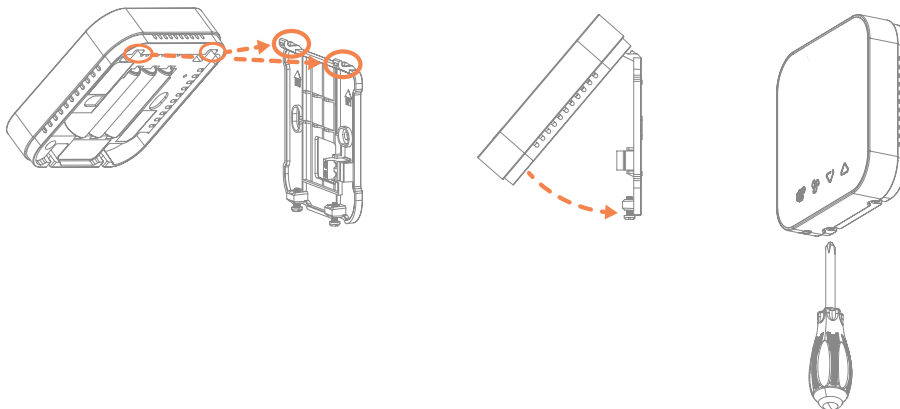

Installation and Wiring Processes

8. Switch the power back on

Restore power to your HVAC system. When the thermostat powers up, install your saved profile from the EC Tool Pro app into the thermostat.

Tap Installation tab, then locate the profile you want to install.

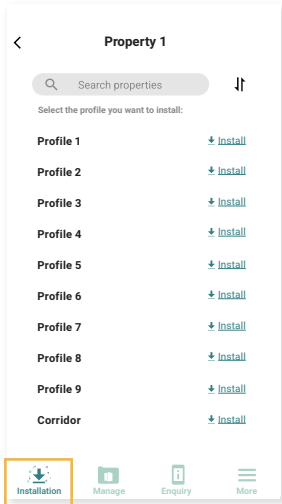

Tap Next after previewing the wiring diagram.

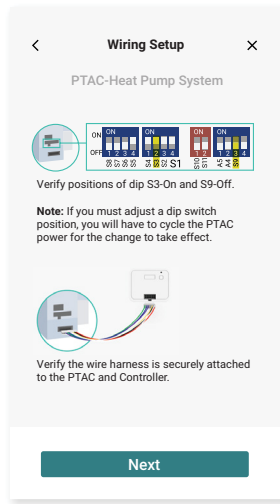

Once you see the Connect Device screen in the app, move to the thermostat. Using Mode (⌘), Up (△), and Down (▽) buttons, select System Settings > System Configuration > Adv. Config. via App > Bluetooth. Using the app, tap Scan QR Code, then use your camera to scan the QR code displayed by the thermostat. Enter the Bluetooth passkey that appears on the thermostat into the app, then tap Start to install the profile. Once the profile has been installed, you will see Success popup in the app and the thermostat. The thermostat will reboot upon completion and tap the Done button in the app. You can now test the thermostat.

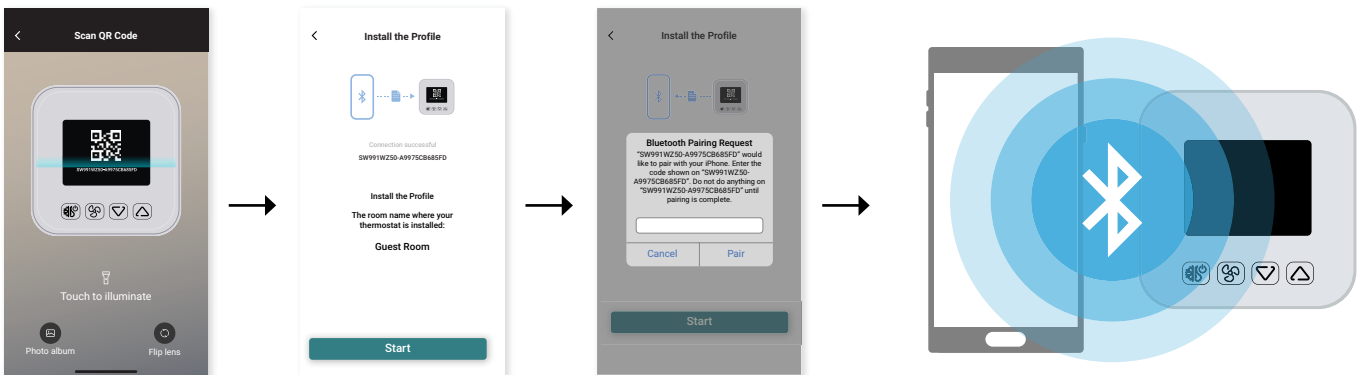

Note

For more information related to creating or managing your thermostat's profile, refer to the Configuration section of this manual.

Configuration

About the EC Tool Pro App

The EC Tool Pro app is an essential tool that will allow you to configure your SW991WZ50 thermostat to control a variety of your Seasons PTAC. Once you have installed the app and completed custom profile, the app will guide you through the wiring configuration and allow you to quickly and securely transfer the profile from the app to your thermostat in seconds.



EC Tool Pro App

Scan the QR code or click the link of one of the App stores



Setting up your thermostat is easy:

1. Get the app.



2. Create a custom profile for your HVAC system.



3. Follow the in-app wiring instructions.

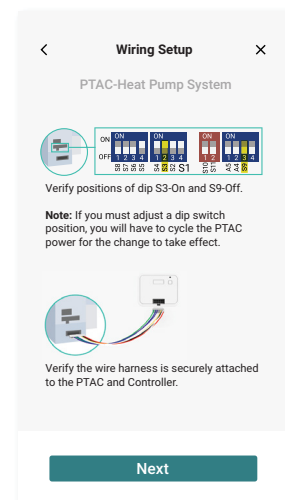

About the EC Tool Pro App

4. Install your profile on the thermostat via Bluetooth and take control of your HVAC system.

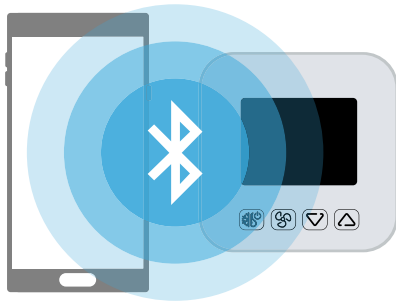

Check for More Information About the EC Tool Pro App

Tap More tab, then About the App to view the version number.

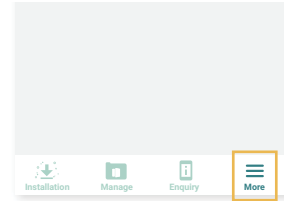

Create Your First Profile

The EC Tool Pro app organizes custom HVAC profiles by property name. When using the EC Tool Pro for the first time, it will be necessary to create a property name under which you will save all of the custom profiles for this property for future reference.

Note

When you visit the EC tool Pro app for the first time after this tool is installed on your smartphone, where no property or profile has been created, the message Create new property! will pop up.

1. Tap Create, then enter your property name (example Property 1) and tap Next.

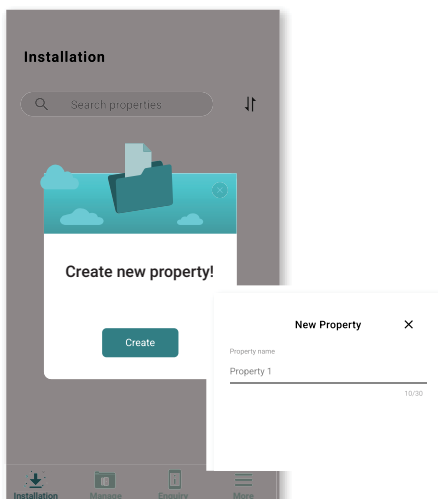

2. Tap Create when the message Create new profile! pops up. Enter your profile name and tap Next.

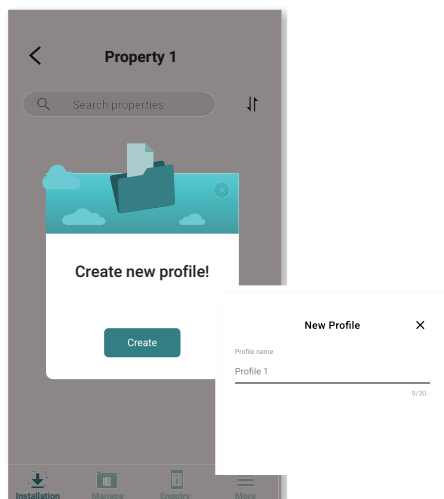

Note

1. Property/profile naming rule: Only numbers, letters and spaces up to 30 characters are allowed.
2. Each property name must be unique and not repeated.
3. Profile names can be duplicated, but must be unique within each property.

Create Your First Profile

3. Tap to select your thermostat's model (SW991WZ50) and tap Next.

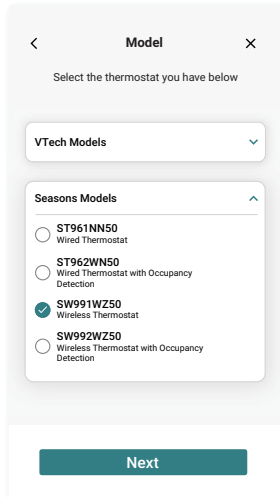

4. Select your system type and tap Next, review the wiring setup, and tap Next.

Note
To verify your system type, review the product model number label. If your model number is SP__E___, select PTAC-Conventional System. If SP__H___, select Heat Pump with Aux Heat System.

5. Tap Create to save this new profile without changing any default settings or values. Or you can define this profile's settings and values on this interface and then tap Create.

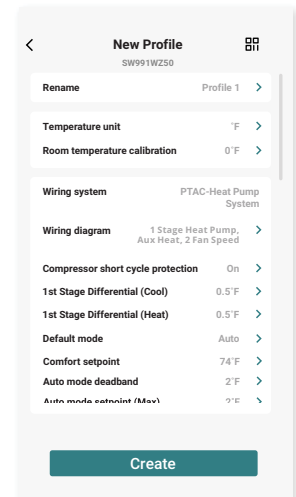

Item	Setting Options or Values	Default Setting or Value
Rename	Fill in the new profile name or ignore this item. Note <ul style="list-style-type: none"> In this item, you can rename the profile name that you have input in step 2. If you don't want to rename it, just ignore this item. Only numbers, letters and spaces up to 30 characters are allowed. Padding profile name with ellipsis on this interface if it's too long. Profile names can be duplicated, but must be unique within each property. 	The auto generated profile name or the profile name you have input in Step 2 (e.g., Profile 1).
Temperature Unit	Fahrenheit (°F) or Celsius (°C)	Fahrenheit (°F)

Note: The Setpoint Range resets to default values after changing temperature unit.

Create Your First Profile

Item	Setting Options or Values	Default Setting or Value
Room Temperature Calibration	Range: -4°F (-2°C) to 4°F (2°C)	0°F (0°C)
	<p>Note: This allows you to adjust the calibration of the ambient room temperature in order to increase its accuracy and ensure that you're getting a proper temperature reading.</p>	
Wiring System	<ul style="list-style-type: none"> • PTAC-Conventional System • PTAC-Heat Pump System 	The option you have chosen in Step 4.
	<p>Note</p> <ul style="list-style-type: none"> • In this item, you can change your wiring system choice in step 4. If you don't want to change it, just ignore this item. • Please consult with your wiring technician to match your choices with the wiring system that will be wired for your thermostat. Selecting an incorrect wiring system may damage your system. 	
Wiring Diagram	<ul style="list-style-type: none"> • 1 Stage Cool, 1 Stage Heat • 1 Stage Heat Pump, Aux Heat 	The option you have chosen in Step 4.
	<p>Note</p> <ul style="list-style-type: none"> • In this item, you can change your wiring diagram choice in step 4. If you don't want to change it, just ignore this item. • Please consult with your wiring technician to match your choices with the wiring diagram that will be wired for your thermostat. Selecting an incorrect wiring diagram may damage your system. 	
Changeover Valve (PTAC-Heat Pump Only)	<ul style="list-style-type: none"> • Energized in cooling (O) • Energized in heating (B) 	Energized in heating (B)
Compressor Short Cycle	On or Off Options when setting to On: 3, 4, or 5 minutes	On - 3 minutes
1 st Stage Differential (Cool)	0.5°F (0.25°C), 1°F (0.5°C), or 1.5°F (0.75°C)	0.5°F (0.25°C)
	<p>Note: 1st Stage Differential (Cool) - determines the level of control and consequently the cycle rate. Adjustable between 0.5°F (0.25°C) and 1.5°F (0.75°C), this is the value above the set point that the temperature must rise to start the cooling. It is also the value below the set point that the temperature must fall for the cooling to stop.</p>	

Create Your First Profile

Item	Setting Options or Values	Default Setting or Value
1 st Stage Differential (Heat)	0.5°F (0.25°C), 1°F (0.5°C), or 1.5°F (0.75°C)	0.5°F (0.25°C)
	<p>Note: Determines the level of control and consequently the cycle rate. Adjustable between 0.5°F (0.25°C) and 1.5°F (0.25°C), this is the value below the set point that the temperature must fall to start the heating. It is also the value above the set point that the temperature must rise for the heating to stop.</p>	
2 nd Stage Differential (Heat) (PTAC-Heat Pump Only)	1°F (0.5°C) or 2°F (1°C)	2°F (1°C)
	<p>Note: Adjustable between 1°F (0.5°C) and 2°F (1°C), this also determines the level of control by determining when to use the 2nd stage of heating. It can also be used to keep 2nd stage heating from coming on too soon when 1st stage is acting to control temperature levels or to keep costly auxiliary heat from coming on too soon when the heat pump is sufficient.</p>	
Default Mode	Auto, Heat, or Cool	Auto
	<p>Note: The default mode will be the primary HVAC mode that is activated each time the system is turned on.</p>	
Comfort Setpoint	Range: 55°F-82°F (13°C-28°C)	74°F (23.5°C)
	<p>Note: The value of Comfort setpoint is not allowed to be bigger than the maximum cool mode setpoint and smaller than the minimum cool mode setpoint.</p>	
Auto Mode Deadband	2°F (1°C), 4°F (2°C), 6°F (3°C), 8°F (4°C), or 10°F (5°C)	2°F (1°C)
	<p>Note: A deadband is a temperature range in which neither heating nor cooling system turns on. The deadband prevents the thermostat from activating heating and cooling in rapid succession. This conserves energy by providing a range of temperatures requiring no energy consumption.</p>	
Auto Mode Setpoint (Max)	Range from comfort setpoint +1°F to 89°F (+0.5°C to 31.5°C)	80°F (26.5°C)
	<p>Note - Example of Auto Mode Setpoint: If the comfort setpoint is set to the default value 74°F (23.5°C), the maximum auto mode setpoint range is 75°F-89°F (24°C-31.5°C).</p>	
Auto Mode Setpoint (Min)	Range from comfort setpoint -1°F to 49°F (-0.5°C to 9.5°C)	65°F (18.5°C)
	<p>Note - Example of Auto Mode Setpoint: If the comfort setpoint is set to the default value 74°F (23.5°C), the minimum auto mode setpoint range is 49°F-73°F (9.5°C-23°C).</p>	

Create Your First Profile

Item	Setting Options or Values	Default Setting or Value
Cool Mode Setpoint (Max)	Range from comfort setpoint +1°F to 89°F (+0.5°C to 31.5°C)	80°F (26.5°C)
Cool Mode Setpoint (Min)	Range from comfort setpoint -1°F to 49°F (-0.5°C to 9.5°C)	65°F (18.5°C)
Heat Mode Setpoint (Max)	Range from comfort setpoint +1°F to 89°F (+0.5°C to 31.5°C)	80°F (26.5°C)
Heat Mode Setpoint (Min)	Range from comfort setpoint -1°F to 49°F (-0.5°C to 9.5°C)	65°F (18.5°C)
Protection Setpoint	On or Off When setting to On, the range of the protection heat setpoint will be 41°F-48°F (5°C-9°C), and the range of the protection cool range 90°F-95°F (32°C-35°C).	Off When setting to On, the default protection heat setpoint will be 45°F (7°C), and the default protection cool setpoint 90°F (32°C).
Fan Operation (PTAC-Conventional Only)	<ul style="list-style-type: none"> Gas (for system control) Electric (for thermostat control) 	Electric (for thermostat control)
Override Mode	On or Off When set to On, the following options will appear: 30, 45, 60, 75, 90, 105, or 120 minutes	On
Schedule	On or Off When setting to On, Create schedule button will appear. Tap Create schedule, select the days of the week and then tap Add block 1 of 4. Set the starting time and temperature and then tap Save.	Off

Note: Each day of the week must be created with block(s). Otherwise, the schedule's setting cannot be saved.

Create Your First Profile

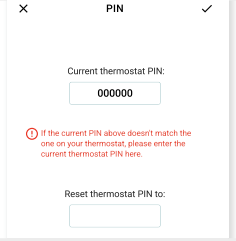
Item	Setting Options or Values	Default Setting or Value
Humidity	On or Off When setting to On, the current room humidity value will be displayed on the screen.	Off
Always-on Display	On or Off When setting to On, the following options will appear: Level 1 (Min), Level 2, or Level 3 (Max)	Always-on Display: On Automatic Display Dimming: On When set to On, the default is Level 2.
Daylight Saving Time	On or Off Note: Daylight savings time (DST), (United States, Canada, and Australia), or summer time (United Kingdom, European Union, and others), is the practice of advancing clocks (typically by one hour) during warmer months so that darkness falls at a later time.	On
Filter Change Reminder	On or Off When setting to On, the following options will appear: 15, 30, 60, 90, 120, 150, or 180 days	Off When set to On, the default is 30 days
PIN	Enter your new 6-digit PIN to reset PIN, or ignore this item to let the current PIN remain unchanged. 	000000

Note

- 6 digits are required for a valid PIN.
- Both profile and thermostat's default PINs are 000000.
- It is allowed to set new PIN identical to current PIN.
- Reset thermostat's PIN
 1. Enter the thermostat's current and new PINs in this item.
 2. Install the updated profile on your thermostat.
- If you need to upload a profile to a thermostat, enter the current PIN of the thermostat you are setting up in this item. To check your thermostat's current PIN, refer to pages 39-41.

Manage Properties and Profiles

Create a Property

1. Tap the Manage tab.

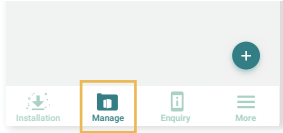

2. Tap the Add button (+).

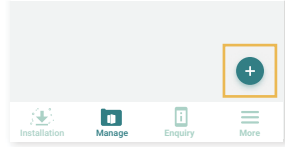

3. Enter your property name and then tap Save.

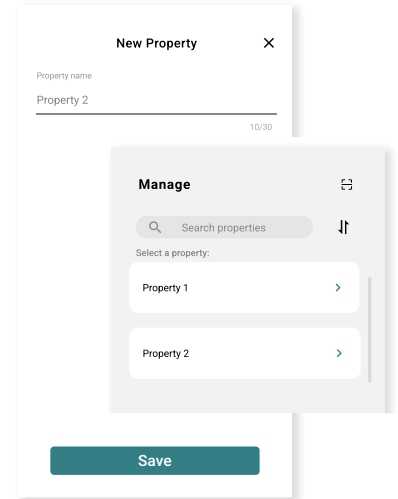

Note

The system will automatically generate a property name during creating a new property, such as Property 2.

Edit a Property

1. Tap the property you want to edit.

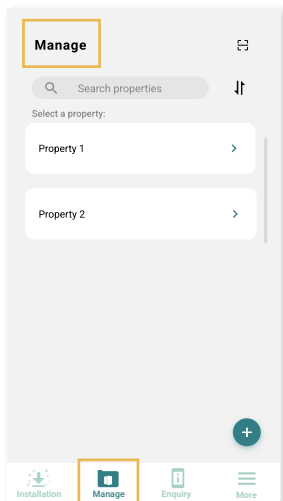

2. Tap the Edit icon (✎), then select Edit Property from the drop down menu and then enter the new property name and tap Save.

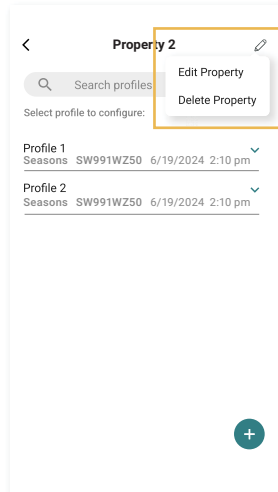

Manage Properties and Profiles

Delete a Property

1. Tap on the property you want to delete.

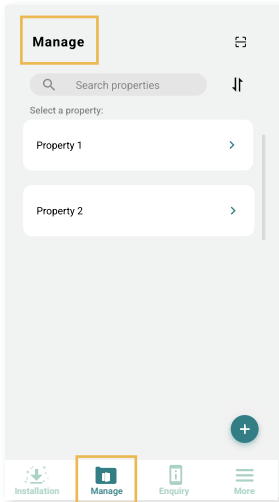

2. Tap on the Edit icon (✎) and select Delete Property from the drop-down menu

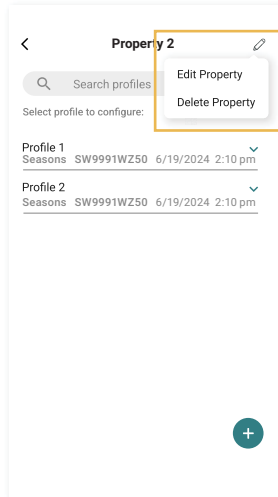

3. Tap Delete on the popup window to confirm deletion.

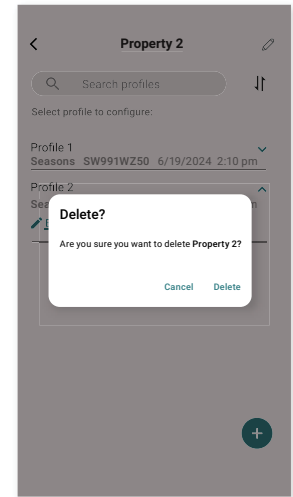

Create a Profile

1. Tap to select a property.

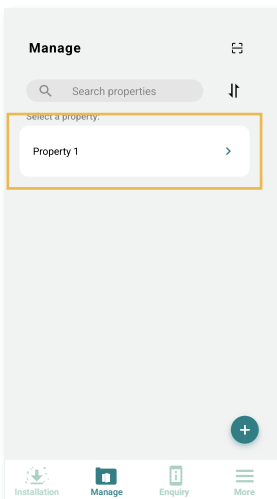

2. Tap the Add icon (+) to create a new profile.

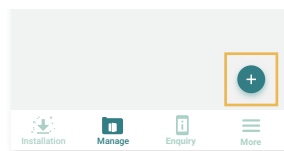

3. Follow the steps on pages 16-21 to create a new profile: Enter your profile name, and select thermostat model, wiring diagram, etc.

