

W992WZ82 Universal Wireless Thermostat

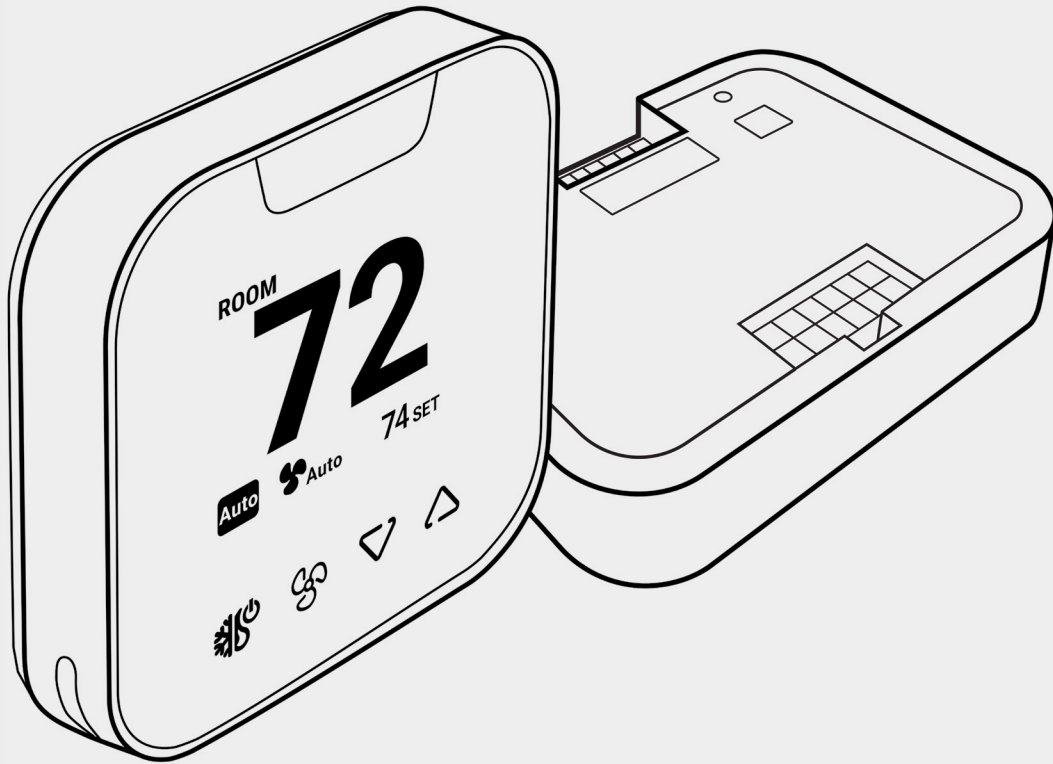

User Manual

Installation | Setup and Configuration | Operation

Table of Contents

Support

tstatsupport@vtechhotelphones.com

Important Safety Instructions	3
FCC and IC Regulatory Statements	5
Battery Warning	6
Maintenance	8
Installation	
Important Things to Know Before Installation	9
In the Box	11
Required but Not Supplied	11
Thermostat and Controller Layouts	12
Specifications	13
Installation Process	17
Setup and Configuration	
Controller Setup	23
About the EC Tool Pro App	24
Create Your First Profile	25
Occupancy Sensor (PIR) Settings	34
Manage Properties and Profiles	35
Install a Saved Profile	40
View and Save Thermostat Profile	42
App Error Messages and Troubleshooting	44
Engineering Menus	50
Configuration via the Thermostat Menu	54
Power Outages	55
Restore Factory Defaults	55
Thermostat Error Alerts and Troubleshooting	56
Operation	
Wake up Screen	58
Set HVAC Mode	59
Set Fan Mode	60
Switch Temperature Unit Between °F and °C	61
Adjust Set Temperature	62
Occupancy Sensor	63
Restore Profile Defaults	63
Warranty	64

Important Safety Instructions

SAVE THESE INSTRUCTIONS

The applied nameplate is located at the bottom or rear of the product.

When using your thermostat equipment, basic safety precautions should always be followed to reduce the risk of fire, electric shock and injury, including the following:

1. This product should be installed by a qualified technician.
2. Read and understand all instructions.
3. Follow all warnings and instructions marked on the product.
4. Do not use liquid or aerosol cleaners. Use a damp cloth for cleaning.
5. Do not expose the product to liquid or install this in wet areas such as bathroom, near a sink, near a swimming pool, or in a damp basement.
6. Do not install this product on an unstable surface.
7. This product should not be installed near or over a radiator or heat register, or in any area where proper ventilation is not provided.
8. This product should be operated only from the type of power source indicated on the marking label.
9. To reduce the risk of electric shock, do not disassemble this product. Opening or removing parts of the thermostat may expose you to dangerous voltages or other risks. Incorrect reassembling can cause electric shock.
10. Remove this product and refer servicing to an authorized service facility under the following conditions:
 - a. If liquid has spilled onto the product.
 - b. If the product has exposed to rain or water.
 - c. If the product does not operate normally by following the operating instructions. Adjust only the controls that are covered by the operating instructions.
 - d. If the product has been dropped resulting in physical damage.
 - e. If the product exhibits a distinct change in performance.
11. Avoid using the thermostat during an electrical storm. There is a remote risk of electric shock.
12. The thermostat should be mounted at a height of less than 6 feet.

CAUTION:

- Keep small metallic objects such as pins and staples away from the thermostat.
- Do not mix old and new batteries and Do not mix alkaline, standard (carbon-zinc) or rechargeable (ni-cad, ni-mh, etc.) batteries.
- Avoid using the battery in the following conditions:
 - High or low extreme temperature during use, storage or transportation.
 - Replacement of a battery with an incorrect type that can defeat a safeguard.
 - Disposal of a battery into fire or a hot oven, or mechanically crushing or cutting of a battery can result in an explosion.
 - Leaving a battery in an extremely high temperature surrounding environment that can result in an explosion or the leakage of flammable liquid or gas.
 - Extremely high temperature and/or extremely low air pressure that can result in an explosion or the leakage of flammable liquid or gas.
- Use 18~24 AWG only.
- For supply connections, use wires rated for 167°F (75°C) minimum.

Instructions de sécurité importantes

CONSERVEZ CES INSTRUCTIONS

La plaque signalétique se trouve en bas ou à l'arrière de l'appareil.

Lors de l'utilisation de l'équipement de votre thermostat, des précautions de base doivent toujours être prises pour réduire les risques d'incendie, d'électrocution et de blessure, notamment les suivantes :

1. Ce produit doit être installé par un technicien qualifié.
2. Lire et comprendre toutes les instructions.
3. Respectez tous les avertissements et toutes les instructions figurant sur le produit.
4. N'utilisez pas de nettoyeurs liquides ou en aérosol. Utilisez un chiffon humide pour le nettoyage.
5. N'exposez pas le produit à des liquides et ne l'installez pas dans des endroits humides, tels qu'une salle de bain, près d'un évier, près d'une piscine ou dans un sous-sol humide.
6. Ne pas installer ce produit sur une surface instable.
7. Ce produit ne doit pas être installé à proximité ou au-dessus d'un radiateur ou d'une bouche de chaleur, ni dans un endroit où une ventilation adéquate n'est pas assurée.
8. Ce produit ne doit être utilisé qu'avec le type de source d'alimentation indiqué sur l'étiquette de marquage.
9. Pour réduire le risque d'électrocution, ne pas démonter ce produit. Ouvrir ou retirer des pièces du thermostat peut vous exposer à des tensions dangereuses ou à d'autres risques. Un réassemblage incorrect peut provoquer une électrocution.
10. Retirez ce produit et confiez-le à un service de réparation agréé dans les conditions suivantes :
 - a. Si du liquide s'est répandu sur le produit.
 - b. Si le produit a été exposé à la pluie ou à l'eau.
 - c. Si le produit ne fonctionne pas normalement en suivant les instructions d'utilisation. Ne réglez que les commandes couvertes par le mode d'emploi.
 - d. Si le produit est tombé et a subi des dommages physiques.
 - e. Si le produit présente un changement distinct de performance.
11. Évitez d'utiliser le thermostat pendant un orage. Il y a un risque d'électrocution.
12. Le thermostat doit être fixé à une hauteur inférieure à 6 pieds.

   MISE EN GARDE :

- Tenir les petits objets métalliques, tels que les épingles et les agrafes à l'écart du thermostat.
- Évitez d'utiliser la pile dans les conditions suivantes :
 - Température élevée ou basse extrême pendant l'utilisation, l'entreposage ou le transport.
 - Remplacement d'une pile par un type de pile incorrect qui peut neutraliser une mesure de protection.
 - L'élimination d'une pile dans le feu ou dans un four chaud, ou l'écrasement ou le découpage mécanique d'une pile, ce qui peut entraîner une explosion.
 - Laisser une batterie dans un environnement à température extrêmement élevée, ce qui peut entraîner une explosion ou une fuite de liquide ou de gaz inflammable.
 - Température extrêmement élevée et/ou pression atmosphérique extrêmement basse pouvant entraîner une explosion ou une fuite de liquide ou de gaz inflammable.
- Utiliser uniquement des câbles 18~24 AWG.
- Pour les connexions d'alimentation, utiliser des fils prévus pour une température minimale de 167°F (75°C).

FCC and IC Regulatory Statements

FCC Compliance Statement

This device complies with Part 15 of the FCC Rules. Operation is subject to the following two conditions: (1) this device may not cause harmful interference, and (2) this device must accept any interference received, including interference that may cause undesired operation.

Warning: Changes or modifications to this unit not expressly approved by the manufacturer could void the user's authority to operate the equipment.

NOTE: This equipment has been tested and found to comply with the limits for a Class B digital device, pursuant to Part 15 of the FCC Rules. These limits are designed to provide reasonable protection against harmful interference in a residential installation. This equipment generates, uses, and can radiate radio frequency energy and, if not installed and used in accordance with the instructions, may cause harmful interference to radio communications. However, there is no guarantee that interference will not occur in a particular installation. If this equipment does cause harmful interference to radio or television reception, which can be determined by turning the equipment off and on, the user is encouraged to try to correct the interference by one or more of the following measures:

- Reorient or relocate the receiving antenna.
- Increase the separation between the equipment and receiver.
- Connect the equipment into an outlet on a circuit different from that to which the receiver is connected.
- Consult the dealer or an experienced radio/TV technician for help.

RF Exposure Information

This equipment complies with FCC radiation exposure limits set forth for an uncontrolled environment. In order to avoid the possibility of exceeding the FCC radio frequency exposure limits, human proximity to the antenna shall not be less than 20cm during normal operation.

ISED Warning

This device complies with Innovation, Science, and Economic Development Canada license exempt RSS standard(s). Operation is subject to the following two conditions:

1. this device may not cause interference.
2. this device must accept any interference, including interference that may cause undesired operation of the device.

Operation in the band 5150–5250 MHz is only for indoor use to reduce the potential for harmful interference to co-channel mobile satellite systems.

⚠ WARNING

- **INGESTION HAZARD:** This product contains a button cell or coin battery. **DEATH** or serious injury can occur if ingested.
- A swallowed button cell or coin battery can cause **Internal Chemical Burns** in as little as **2 hours**.
- **KEEP** new and used batteries **OUT OF REACH of CHILDREN**.
- **Seek immediate medical attention** if a battery is suspected to be swallowed or inserted inside any part of the body.
- The product contains **Non-replaceable batteries**.
Compatible battery type: CR1220
Nominal battery voltage: 3V



ⓘ Cautions

- The factory installed clock backup battery is not replaceable and rechargeable. There may be a risk of explosion if a wrong type of clock backup battery is used. Use only the factory installed non-replaceable battery (Compatible battery type CR1220, Nominal battery voltage 3V) and do NOT recharge the battery.
- Even used batteries may cause severe injury or death.
- Do not force discharge, recharge, disassemble, heat above 212°F (100°C) or incinerate. Doing so may result in injury due to venting, leakage or explosion resulting in chemical burns.
- Call a local poison control center for treatment information.
- Remove and immediately recycle or dispose of used batteries according to local regulations and keep away from children. Do NOT dispose of batteries in household trash or incinerate.
- Battery must be removed from the thermostat before it is scrapped.
- Thermostat must be disconnected from the supply mains when removing the battery.
- Battery is to be disposed of safely.

⚠️ AVERTISSEMENT

- **RISQUE D'INGESTION** : Ce produit contient une pile bouton ou une pile bouton. **LA MORT** ou des blessures graves peuvent survenir en cas d'ingestion.
- Une pile bouton ou une pièce de monnaie avalée peut provoquer des **brûlures chimiques internes** en seulement **2 heures**.
- **CONSERVEZ** piles neuves et usagées **HORS DE LA PORTÉE des ENFANTS**.
- **Consulter immédiatement un médecin** en cas de suspicion d'ingestion ou d'insertion d'une pile dans une partie quelconque du corps.
- Le produit contient **Piles non remplaçables**.
Pile compatible de type CR1220. Tension nominale de la pile de 3 V.



ⓘ Mises en garde

- La pile de secours de l'horloge installée en usine n'est ni remplaçable ni rechargeable. Il peut y avoir un risque d'explosion si l'on utilise un mauvais type de pile de sauvegarde de l'horloge. Utilisez uniquement la pile non remplaçable installée en usine (pile compatible de type CR1220, tension nominale de la pile 3V) et ne rechargez PAS la pile.
- La pile de secours de l'horloge installée en usine n'est ni remplaçable ni rechargeable. Il peut y avoir un risque d'explosion en cas d'utilisation d'un mauvais type de pile de sauvegarde de l'horloge. Utilisez uniquement la pile non remplaçable installée en usine (pile compatible de type CR1220, tension nominale de la pile 3V) et ne rechargez PAS la pile.
- Les piles, même usagées, peuvent provoquer des blessures graves, voire mortelles.
- Ne pas forcer la décharge, ne pas recharger, ne pas démonter, ne pas chauffer à plus de 100°C (212°F) et ne pas incinérer. Vous risqueriez de vous blesser en raison d'un dégagement, d'une fuite ou d'une explosion entraînant des brûlures chimiques.
- Appelez un centre antipoison local pour obtenir des informations sur le traitement.
- Retirez les piles usagées et recyclez-les immédiatement ou mettez-les au rebut conformément aux réglementations locales et tenez-les hors de portée des enfants. Ne jetez PAS les piles dans les ordures ménagères et ne les incinerez pas.
- La pile doit être retirée du thermostat avant d'être mise au rebut.
- Le thermostat doit être déconnecté du réseau d'alimentation lors du retrait de la pile, qui doit être mise au rebut en toute sécurité.
- La pile doit être mise au rebut en toute sécurité.

Maintenance

Avoid rough treatment

Place the thermostat down gently. Save the original packing materials to protect your thermostat if you ever need to ship it.

Avoid water

Your thermostat can be damaged if it gets wet. Do not use the thermostat outdoors in the rain or handle it with wet hands. Do not install thermostat near a sink, bathtub, or display.

Electrical storms

Electrical storms can sometimes cause power surges harmful to electronic equipment. For your own safety, take caution when using electrical appliances during storms.

Cleaning your thermostat

Your thermostat has a durable plastic casing that should retain its luster for many years. Clean it only with a soft cloth slightly dampened.

Installation

Important Things to Know Before Installation

- This product should be installed by a qualified technician.
- Carefully read these instructions. You could damage this product or cause a hazardous condition if you fail to follow these instructions.
- Electrical Hazard Caution: Turn OFF power to your HVAC system before installation. Failure to disconnect the power before beginning to install this product can cause electrical shock or equipment damage.
- Do not over-tighten the screws during mounting.

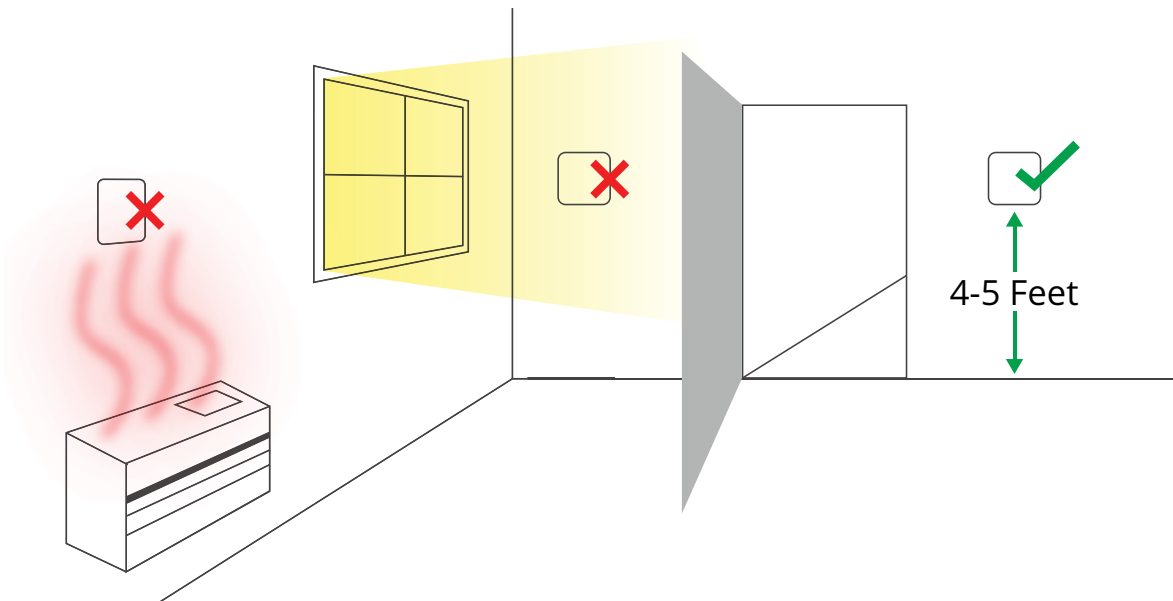

The thermostat **should be mounted:**

- Approximately 4 - 5 feet above the floor
- In a central location with average temperature and humidity
- On an interior wall that is easily accessible
- In a location with good air circulation

The thermostat **should not be mounted:**

- Where it is exposed to direct sunlight
- To a wall that contains concealed chimneys or pipes
- Where there is obstructed air flow such as in corners or behind doors
- Directly above or below an hot or cold air ducts
- On an exterior wall

Ce qu'il faut savoir avant l'installation

- Ce produit doit être installé par un technicien qualifié.
- Lisez attentivement ces instructions. Vous risquez d'endommager ce produit ou de provoquer une situation dangereuse si vous ne suivez pas ces instructions.
- Risque électrique Attention : Coupez l'alimentation de votre système de chauffage, de ventilation et de climatisation avant l'installation. Si vous ne coupez pas l'alimentation avant de commencer l'installation de ce produit, vous risquez de vous électrocuter ou d'endommager l'équipement.
- Ne pas trop serrer les vis pendant le montage.

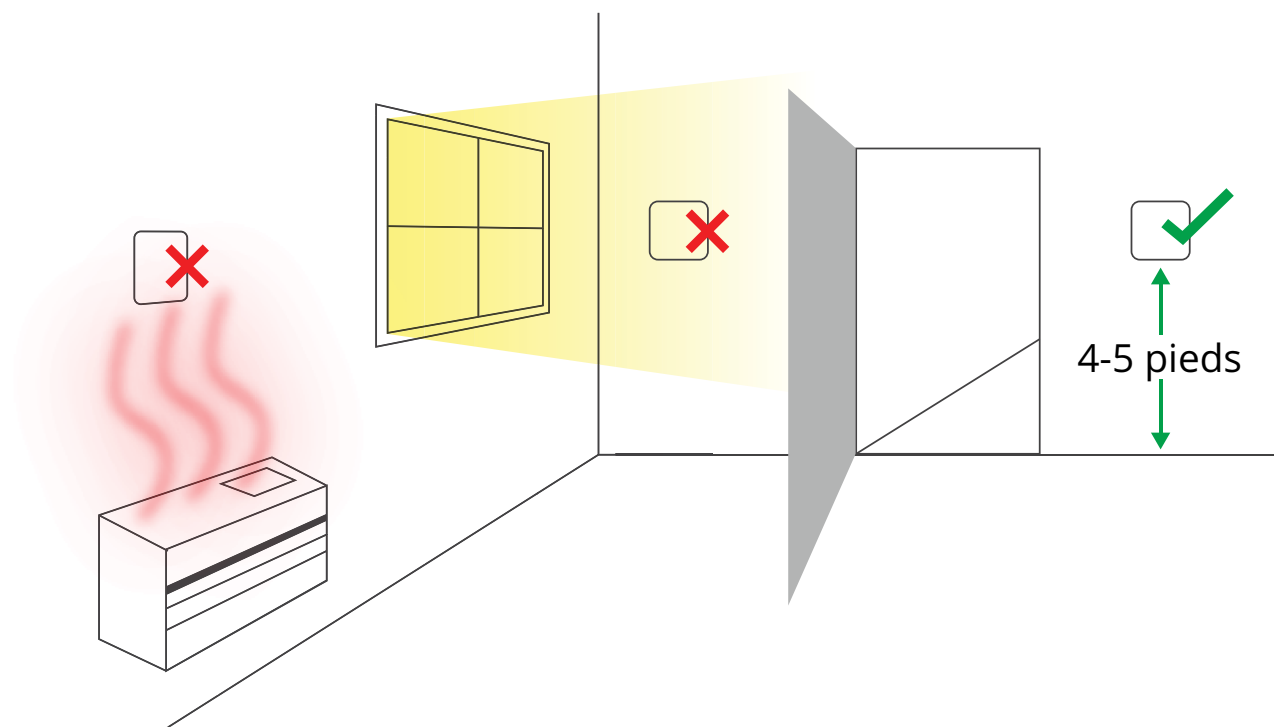

Le thermostat **doit être installé** :

- Environ 4 à 5 pieds au-dessus du sol
- Dans un endroit central où la température et l'humidité sont moyennes
- Sur un mur intérieur facilement accessible
- Dans un endroit où l'air circule bien

Le thermostat **ne doit pas être installé** :

- Lorsqu'il est exposé à la lumière directe du soleil
- Sur un mur qui contient des cheminées ou des tuyaux cachés
- Là où le débit d'air est obstrué, par exemple dans les coins ou derrière les portes
- Directement au-dessus ou au-dessous d'un conduit d'air chaud ou froid
- Sur un mur extérieur

In the Box



Thermostat

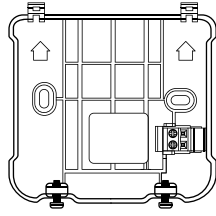

Wall Plate

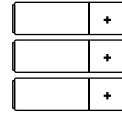

AA Batteries x3

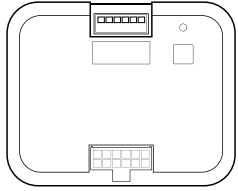

Controller

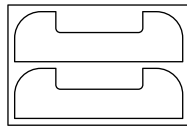

Double-sided Tape

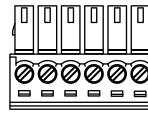

Connector

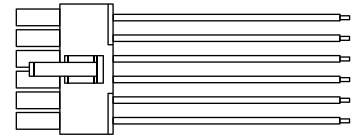

Wire Harness

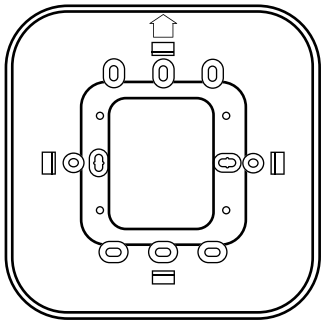

Universal Deco Plate

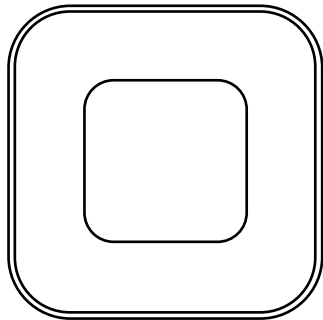

Deco Plate Cover

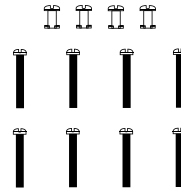

T-Locks & Junction Box Screws

Required but Not Supplied

- Screwdriver set
- Drill and drill bits; 3/16" for drywall and 7/32" for plaster
- Pencil
- Level

Device Required

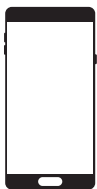

Smartphone with Bluetooth® feature

- iOS 15 or higher
- Android 12.0 or higher

Thermostat and Controller Layouts

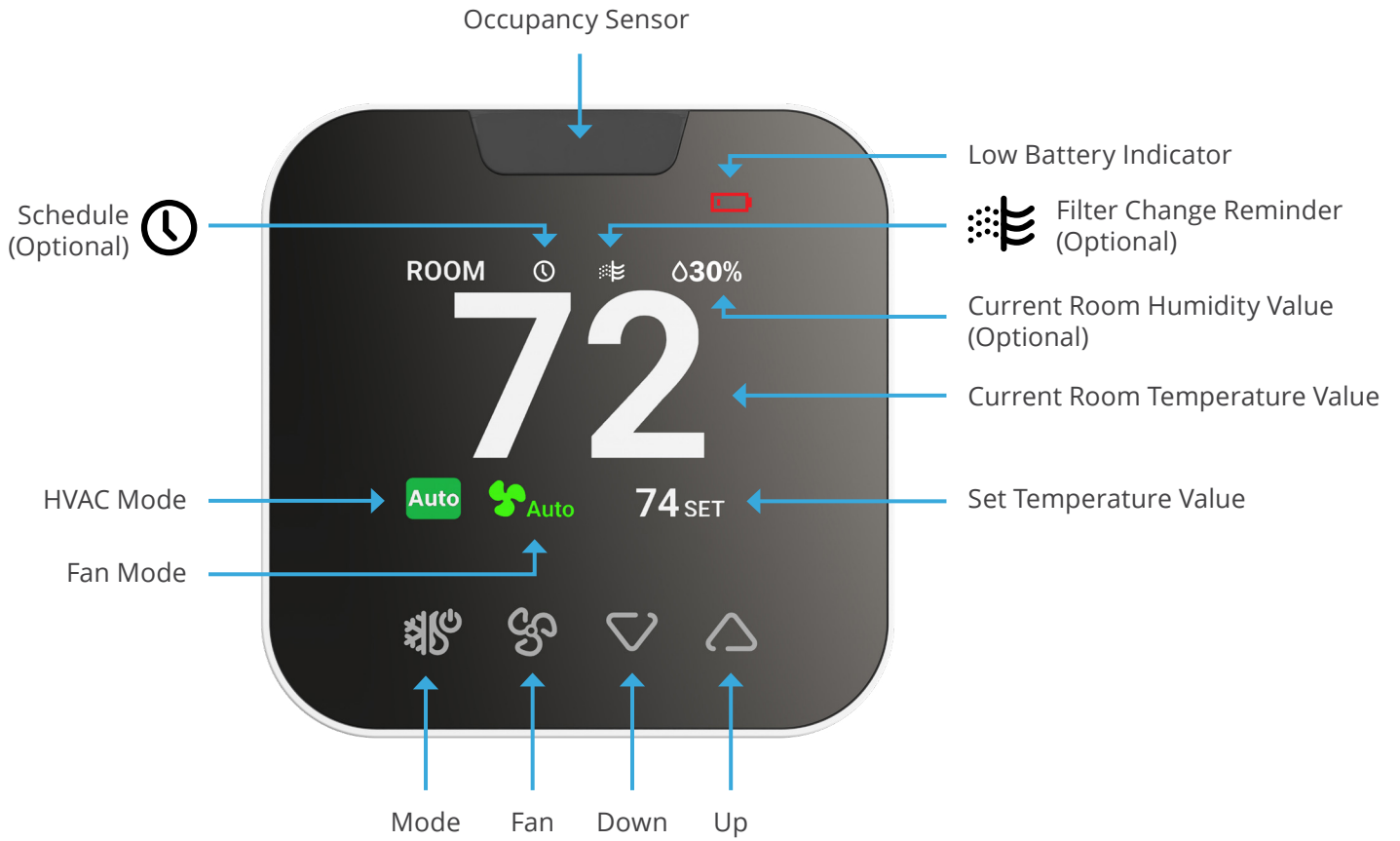

Note

Only when the humidity, schedule, and filter change reminder features are enabled via the EC Tool Pro app, can the current room humidity, schedule, and filter change reminder be displayed on the screen.

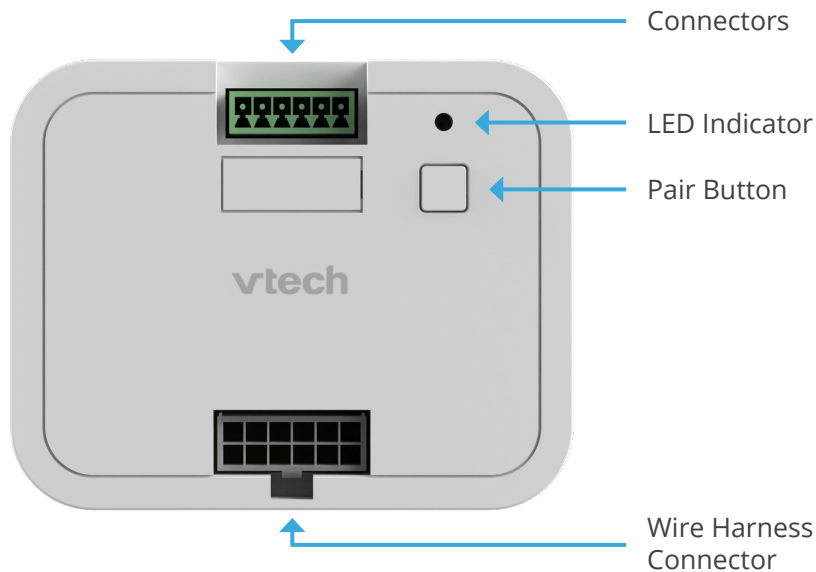

Specifications

	Thermostat	Controller
Product Dimensions	3.9" x 3.9" x 1" (9.9cm x 9.9cm x 2.6cm)	3.94" x 3.15" x 0.94" (10cm x 8cm x 2.4cm)
Mounting Type	Surface Mount, Junction Box*	Double-sided Tape
HVAC Systems	PTAC/VTAC/Heat Pump/Conventional/ FCU	PTAC/VTAC/Heat Pump/Conventional/ FCU
Power Requirement	Either 3 x AA battery or 24V AC (60Hz 0.5A with "C" common wire)	Input: 24V AC 60Hz 3.0A with "C" common wire Output: 3.0A Max @ 24V AC
Battery Life	12 months	—
Display	2.8" TFT (240 x 320, RGB)	—
Display Back Light	Configurable - Dimming or Off	—
Display Brightness	3 Levels	—
Number of Buttons	4 Touch Buttons	1, Pair Button
LED Indicator	1, Red Color	1, Dual Color
HVAC System Modes	Auto, Cool, Heat, and Off	—
Fan Modes	Fan Modes in 1 Fan Speed Setting: Auto, On, and Off Fan Modes in 2 Fan Speed Setting: Auto, Low, High, and Off Fan Modes in 3 Fan Speed Setting: Auto, Low, Mid, High, and Off	—
Temperature Set Range	49°-89°F / 9.5°-31.5°C	—
Room Temperature Display Range	32°-122°F / 0°-50°C (If the real room temperature drops below 0°C or rises above 50°C, the thermostat screen will still show 0°C or 50°C.)	—
Occupancy Sensing	Maximum Detection Distance: 9 m	—

* A universal deco plate kit is required for junction box mounting.

Specifications

	Thermostat	Controller
Room Humidity Display Range	0-95% RH (If the real room humidity drops below 0% or rises above 95%, the thermostat screen will still show 0% or 95%.)	—
Terminal Connections	C, R	SC (GND), Ds1, Rs2, Rs1, Ao1 U1, U1, U2, U2, Y2 Gh, W2 O/B Gm, G Gl, W3 E, Y1, W1 Gh, C, R
Max Stage Supported	PTAC/VTAC: 2H1C 2-Speed Fan Heat Pump: 3H2C 1-Speed Fan Conventional: 2H1C 1-Speed Fan FCU: 1H1C 3-Speed Fan	PTAC/VTAC: 2H1C 2-Speed Fan Heat Pump: 3H2C 1-Speed Fan Conventional: 2H1C 1-Speed Fan FCU: 1H1C 3-Speed Fan
Recommended Wire	18 Gauge (Solid) - max. length: 40 m 24 Gauge (Solid) - max. length: 11 m	18 Gauge (Solid) - max. length: 40 m 24 Gauge (Solid) - max. length: 11 m
Disconnection Type	—	1.B
Rated Impulse Voltage	—	800V
Pollution Degree	—	2
Automation Cycle	—	50,000

Spécifications

	Thermostat	Contrôleur
Dimensions du produit	3,9 po x 3,9 po x 1 po (9,9 cm x 9,9 cm x 2,6 cm)	3,94 po x 3,15 po x 0,94 po (10 cm x 8 cm x 2,4 cm)
Type de fixation	Fixation en surface, boîte de jonction*	Ruban adhésif double face
Systèmes CVC	PTAC/VTAC/Heat Pump/Conventionel/ FCU	PTAC/VTAC/Heat Pump/Conventionel/ FCU
Exigences d'alimentation	Soit 3 piles AA ou 24 V CA (60 Hz 0,5 A avec fil commun "C")	Entrée : 24 V CA 60 Hz 3,0 A avec fil commun "C" Sortie : 3,0 A max. @ 24 V A
Autonomie de la pile	12 mois	—
Affichage	2,8 po TFT (240 x 320, RVB)	—
Rétroéclairage de l'écran	Configurable - Gradation ou désactivation	—
Luminosité de l'affichage	3 niveaux	—
Nombre de boutons	4 boutons tactiles	1 paire de boutons
Voyant à DEL	1 de couleur rouge	1 à deux couleurs
Modes de systèmes CVC	Auto, Cool, Heat, et Off	—
Modes du ventilateur	Modes de ventilation en 1 réglage de la vitesse de ventilation : Auto, On, et Off Modes de ventilation en 2 réglages de vitesse de ventilation : Auto, Low, High, et Off Modes de ventilation en 3 réglages de vitesse de ventilation : Auto, Low, Mid, High, et Off	—
Plage de réglage de la température	49-89°F / 9,5-31,5°C	—
Plage d'affichage de la température ambiante	32-122°F / 0-50°C (Si la température réelle de la pièce descend en dessous de 0°C ou monte au-dessus de 50°C, l'écran du thermostat indiquera toujours 0°C ou 50°C).	—
Détection de l'occupation	Distance de détection maximale : 9 m	—

* Une trousse de plaque décorative universelle est nécessaire pour le montage de la boîte de jonction.

Spécifications

	Thermostat	Contrôleur
Plage d'affichage de l'humidité ambiante	0-95% RH (Si l'humidité réelle de la pièce descend en dessous de 0% ou augmente au-dessus de 95 %, l'écran du thermostat indiquera toujours 0 % ou 95 %).	—
Connexions terminales	C, R	SC (GND), Ds1, Rs2, Rs1, Ao1 U1, U1, U2, U2, Y2 Gh, W2 O/B Gm, G Gl, W3 E, Y1, W1 Gh, C, R
Stade maximum supporté	PTAC/VTAC : 2H1C Ventilateur à 2 vitesses Pompe à chaleur : 3H2C Ventilateur à 1 vitesse Conventionnel : 2H1C Ventilateur à 1 vitesse FCU : 1H1C Ventilateur à 3 vitesses	PTAC/VTAC : 2H1C Ventilateur à 2 vitesses Pompe à chaleur : 3H2C Ventilateur à 1 vitesse Conventionnel : 2H1C Ventilateur à 1 vitesse FCU : 1H1C Ventilateur à 3 vitesses
Fil recommandé	Calibre 18 (solide) - longueur max. longueur : 40 m Calibre 24 (solide) - longueur max. Longueur : 11 m	Calibre 18 (solide) - longueur max. longueur : 40 m Calibre 24 (solide) - longueur max. Longueur : 11 m
Type de déconnexion	—	1.B
Tension d'impulsion nominale	—	800 V
Degré de pollution	—	2
Cycle d'automatisation	—	50,000

Installation Process

1. Power off your HVAC system

Disconnecting the power protects you and avoids damage. After disconnecting, adjust the set temperature to confirm the system is off.

2. Verify system compatibility

Inspect the remote wall thermostat wire connections to verify system compatibility.

CAUTION: The W992WZ82 is compatible with low-voltage (24V), single transformer systems only. If you inspect and find any of the following, then the W992WZ82 is not compatible with your system.

1. Labels on the wiring or old thermostat warning of High Voltage, 120V, or 240V connections.
2. Thick electrical wires that are connected using wire nuts.
3. If your old thermostat supports RC and RH terminals that are wired separately (not connected via jumper wire)

If you have any enquiries about system compatibility, email tstatsupport@vtechhotelphones.com.

3. Controller Mounting

- Up to 200 feet away from the thermostat with no obstructions or walls in between, or up to 100 feet away with standard building materials in between.
- Attach the controller behind the front grill of the PTAC and secure it with the supplied double-sided tape.

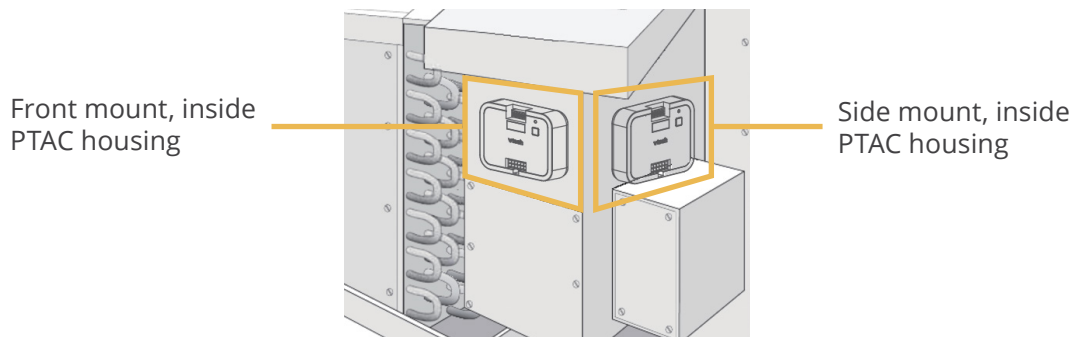

For controller wiring, please refer to the W992WZ82 Wiring Guide.

Installation Process

4. Attach the wall plate

Mounting Option 1: Direct Wall Mounting

Hold the wall plate up to the wall where you want the thermostat to be mounted. Make sure that the wire bundle aligns near the center of the wall plate. Verify the plate is level with a bubble level, then mark the screw positions through the screw holes in the wall plate.

Using your marks as reference, drill 2 holes and install the provided wall anchors. If you will be using c-wire or 24vac adapter to power the thermostat, route the wires through the opening in the center of the wall plate, then secure it to the wall with the provided screws. The slots in the wall plate will help to compensate for any minor misalignment.

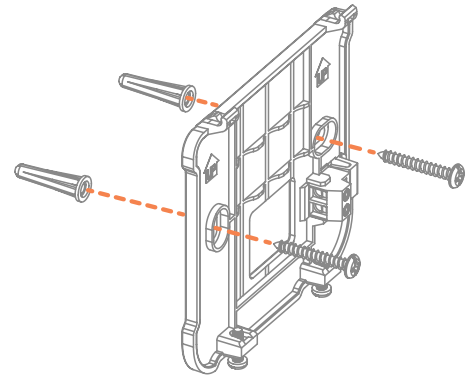

Mounting Option 2: Direct Wall Mounting with Deco Plate Kit

Hold the deco plate up to the wall where you want the thermostat to be mounted. Make sure that the wire bundle aligns near the center of the deco plate. Verify the plate is level with a bubble level, then mark the screw positions through the screw holes in the deco plate.

1. Push the cover towards the deco plate until it clicks into place.
2. Using your marks as reference, drill 2 holes and install the provided wall anchors. Route the wires through the opening in the center of the deco plate, then the wall plate.
3. Align the screw holes and secure them to the wall with the provided screws. The slots in the wall plate will help to compensate for any minor misalignment.

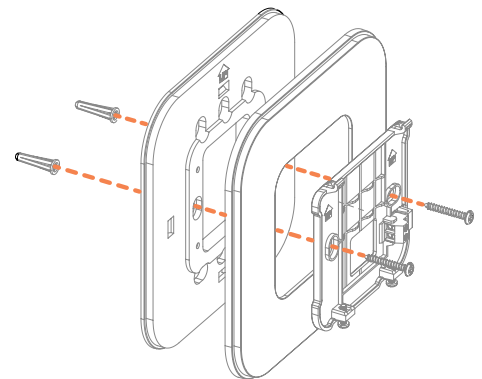

Installation Process

4. Attach the wall plate

Mounting Option 3: Junction Box Mounting with Deco Plate Kit

1. Attach the deco plate to the junction box with the provided junction box screws.
2. Push the cover towards the deco plate until it clicks into place.
3. Attach the wall plate to the deco plate with the provided T locks.
4. Route the wires in the junction box through the openings in the centers of the deco plate and the wall plate.

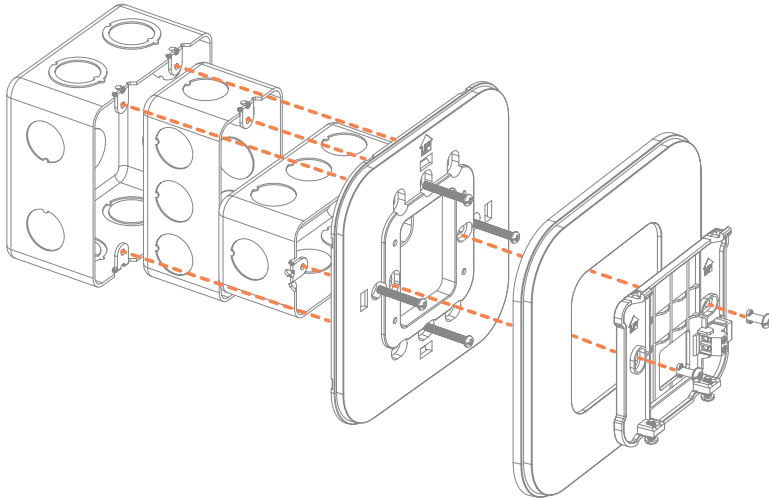

5. Install batteries or Connect thermostat power wires

Battery powered application: Install 3 x AA batteries into the rear housing of the thermostat.

C-Wire/24VAC supply application: Route the 24V C (common) and R (load) wires through the center of the wall plate. Using a precision screw driver, connect the wires to the C and R terminals. Once connected, press down on the wires to ensure they are flush with the wall plate. Once wires are securely connected, press the wires down to ensure they are flush with the wall plate.

6. Attach the thermostat

Swing the thermostat into position by engaging the lugs at the top of the wall plate before pushing it carefully home into its plug-in terminal block.

Lock the thermostat into place by tightening the 2 Phillips screws located on the bottom edge of the thermostat. Restore power to your HVAC system.

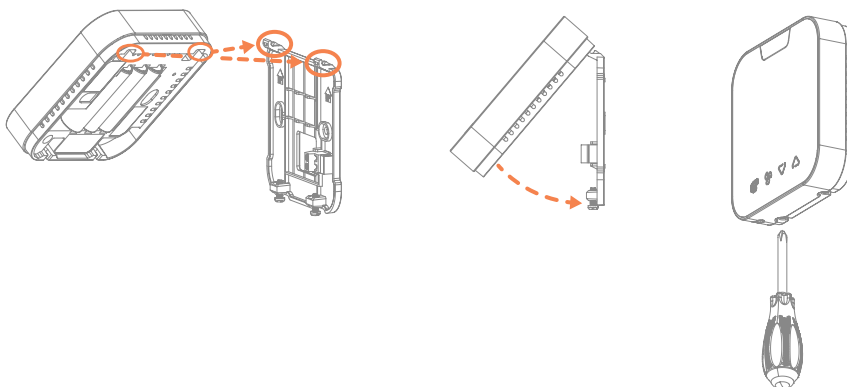

For controller wiring, please refer to the W992WZ82 Wiring Guide.

Processus d'installation

1. Mettez votre système CVC hors tension

Le fait de couper l'alimentation électrique vous protège et évite les dommages. Après avoir coupé l'alimentation, réglez la température de consigne pour confirmer que le système est éteint.

2. Vérifiez la compatibilité du système

Inspecter les connexions des fils du thermostat mural à distance pour vérifier la compatibilité du système.

MISE EN GARDE : Le W992WZ82 n'est compatible qu'avec les systèmes à basse tension (24 V), à transformateur unique. Si vous inspectez et trouvez l'un des éléments suivants, le W992WZ82 n'est pas compatible avec votre système.

1. Étiquettes sur le câblage ou l'ancien thermostat avertissant des connexions à haute tension, 120 V ou 240 V.
2. Fils électriques épais qui sont connectés à l'aide d'écrous à fils.
3. Si votre ancien thermostat comporte des bornes RC et RH câblées séparément (non reliées par un fil de liaison).

Si vous avez des questions sur la compatibilité des systèmes, envoyez un courriel à l'adresse suivante tstatsupport@vtechhotelphones.com.

3. Fixation du contrôleur

- Jusqu'à une distance de 200 pieds du thermostat sans obstacles ni murs entre les deux, ou jusqu'à une distance de 100 pieds avec des matériaux de construction standard entre les deux.
- Fixez le contrôleur derrière la grille avant du PTAC et fixez-le avec le ruban adhésif double face fourni.

Montage frontal,
à l'intérieur du
boîtier du PTAC

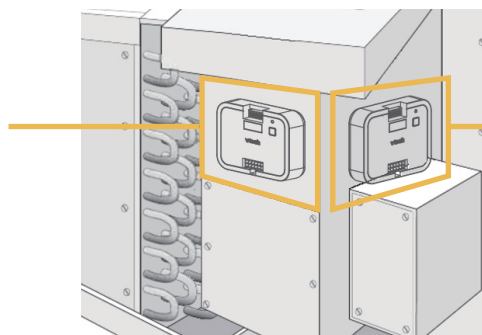

Montage latéral,
à l'intérieur du
boîtier PTAC

Pour le câblage du contrôleur, veuillez vous référer au guide de câblage du W992WZ82.

Processus d'installation

4. Fixer la plaque murale

Option de montage 1 : Montage mural direct

Tenez la plaque murale contre le mur à l'endroit où vous voulez installer le thermostat. Assurez-vous que le faisceau de fils est aligné près du centre de la plaque murale. Vérifiez que la plaque est de niveau à l'aide d'un niveau à bulle, puis marquez les positions des vis à travers les trous de vis de la plaque murale.

En vous référant à vos marques, percez deux trous et installez les ancrages muraux fournis. Si vous utilisez un fil en cuivre ou un adaptateur 24 V CA pour alimenter le thermostat, faites passer les fils par l'ouverture au centre de la plaque murale, puis fixez-la au mur à l'aide des vis fournies. Les fentes de la plaque murale permettent de compenser tout désalignement mineur.

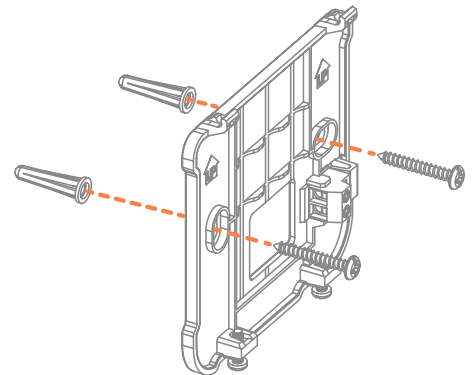

Option de montage 2 : Fixation murale directe avec la trousse de plaque décorative

Tenez la plaque décorative contre le mur à l'endroit où vous souhaitez installer le thermostat. Assurez-vous que le faisceau de fils est aligné près du centre de la plaque. Vérifiez que la plaque est de niveau à l'aide d'un niveau à bulle, puis marquez les positions des vis à travers les trous de vis de la plaque décorative.

1. Pousser le couvercle vers la plaque décorative jusqu'à ce qu'il s'enclenche.
2. En vous référant à vos marques, percez deux trous et installez les ancrages muraux fournis. Faites passer les câbles par l'ouverture au centre de la plaque décorative, puis par la plaque murale.
3. Alignez les trous de vis et fixez-les au mur à l'aide des vis fournies. Les fentes de la plaque murale permettent de compenser tout léger défaut d'alignement.

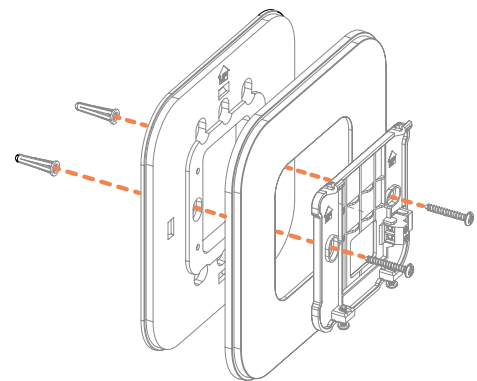

Processus d'installation

4. Fixer la plaque murale

Option de montage 3 : Montage sur boîte de jonction avec kit de plaque décorative

1. Fixer la plaque décorative à la boîte de jonction à l'aide des vis de la boîte de jonction fournies.
2. Pousser le couvercle vers la plaque décorative jusqu'à ce qu'il s'enclenche.
3. Fixer la plaque murale à la plaque décorative à l'aide des verrous en T fournis.
4. Faites passer les fils de la boîte de jonction par les ouvertures situées au centre de la plaque décorative et de la plaque murale.

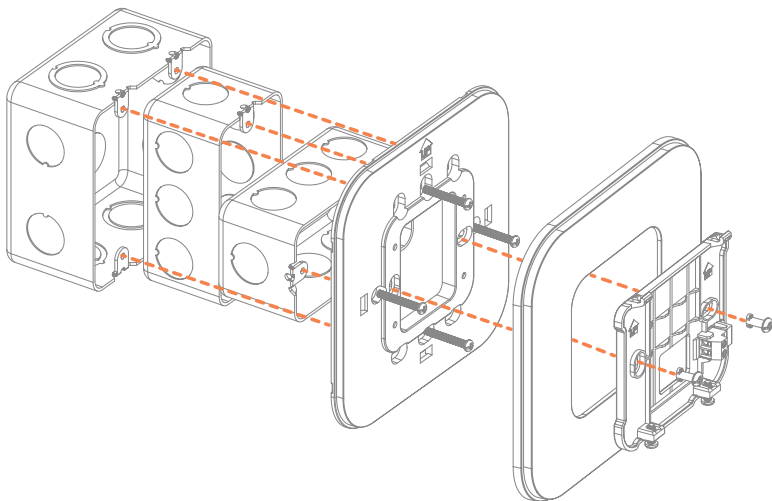

5. Installer les piles ou connecter les fils d'alimentation du thermostat

Application alimentée par piles : Installez 3 piles AA dans le boîtier arrière du thermostat.

Application de l'alimentation C-Wire/24 V CA : Faites passer les fils 24 V CA (commun) et R (charge) par le centre de la plaque murale. À l'aide d'un tournevis de précision, connectez les fils aux bornes C et R. Une fois connectés, appuyez sur les fils pour vous assurer qu'ils affleurent la plaque murale. Une fois les fils solidement connectés, appuyez sur les fils pour vous assurer qu'ils sont au même niveau que la plaque murale.

6. Fixer le thermostat

Faites pivoter le thermostat en position en engageant les ergots situés en haut de la plaque murale avant de l'enfoncer avec précaution dans son bornier enfichable.

Verrouillez le thermostat en place en serrant les deux vis Phillips situées sur le bord inférieur du thermostat.

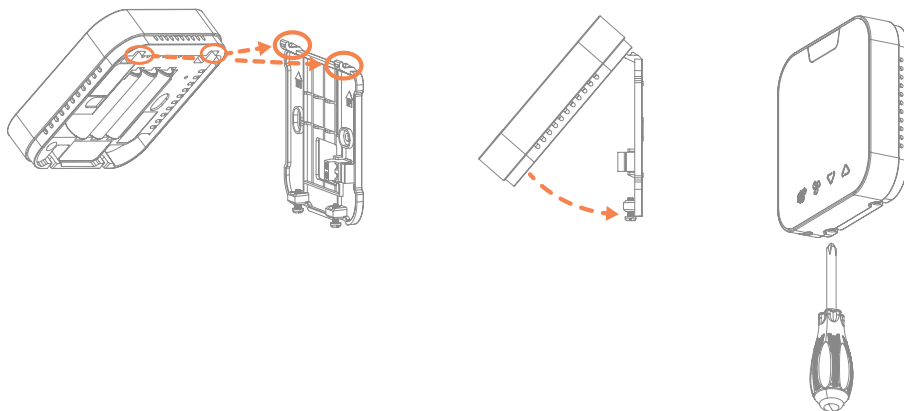

Pour le câblage du contrôleur, veuillez vous référer au guide de câblage du W992WZ82.

Setup and Configuration

Controller Setup

Tricolor LED	Condition	Note
Flashing Green	Searching / establishing Zigbee connection	<ul style="list-style-type: none">• Seen when controller first connected to power and searching for paired devices.• To initiate the pairing of a new device, press and hold pair button for ~five seconds, then follow the Register Device process in thermostat engineering menu.• To cancel the pairing process, press and hold pairing for 10 seconds.
Solid Green	Communicating with thermostat and operating normally	—
Flashing Yellow	Removing all paired devices from system / factory resetting	Occurs during the reset process while removing all connected devices. Once LED returns to solid yellow, follow procedure to re-pair the thermostat to the controller to restore functionality.
Solid Yellow	No devices registered to this controller	Controller may have been reset and registration deleted by a guest or maintenance. To resolve, follow procedure for re-pairing the thermostat to the controller.
Alternating Green / Red	Controller lost communication with the thermostat	After disconnecting the thermostat, the controller keeps searching for the thermostat.
Flashing Blue	Bluetooth activated and in discovery mode	—
Solid Blue	Bluetooth connected to the smartphone app	—
Alternating Purple / Blue	Attempting to reconnect to the DMS	Verify that the DMS connection settings are accurate for the property and that there is no interruption in service. If setting changes are required, edit the DMS section of the thermostat profile then re-provision the thermostat.
Solid Red	Error	Any problems that cause the HVAC or Controller to not work. Please contact the authorized technical support.

About the EC Tool Pro App

The EC Tool Pro app is an essential tool that will allow you to configure your VTech W992WZ82 thermostat to control a variety of HVAC systems across multiple properties. Once you have installed the app and created a custom profile, the app will guide you through the wiring instructions and allow you to quickly and securely transfer the profile from the app to your thermostat in seconds.



EC Tool Pro App

Scan the QR code or click the link of one of the App stores



Setting up your thermostat is easy:

1. Get the app.



2. Create a custom profile for your HVAC system.



3. Follow the in-app wiring instructions.
Example diagram:

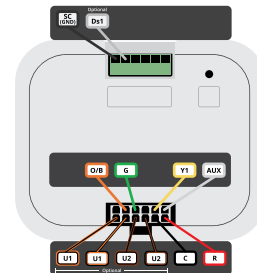

4. Install your profile on the thermostat via Bluetooth and take control of your HVAC system.

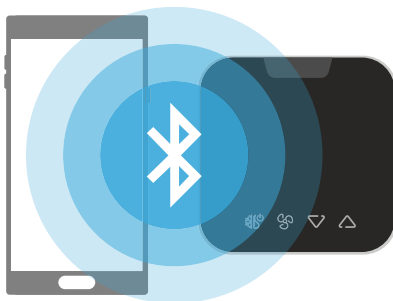

Check for More Information About the EC Tool Pro App

Tap More tab, then About the App to view the version number.

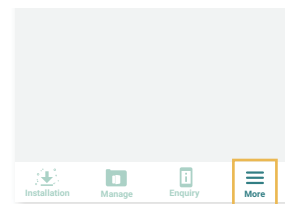

Create Your First Profile

The EC Tool Pro app organizes custom HVAC profiles by property name. When using the EC Tool Pro for the first time, it will be necessary to create a property name under which you will save all of the custom profiles for this property for future reference.

Note

When you visit the EC tool Pro app for the first time after this tool is installed on your smartphone, where no property or profile has been created, the message Create new property! will pop up.

1. Tap Create, then enter your property name (example Property 1) and tap Next.

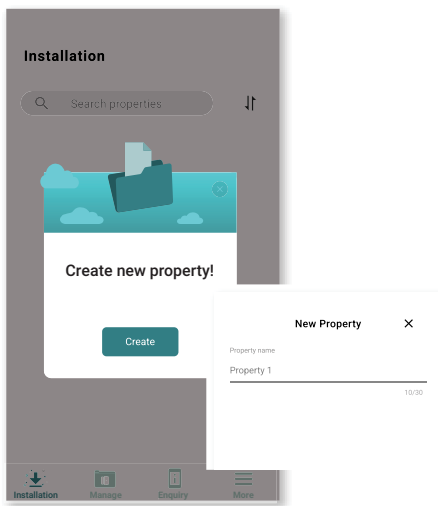

2. Tap Create when the message Create new profile! pops up. Enter your profile name and tap Next.

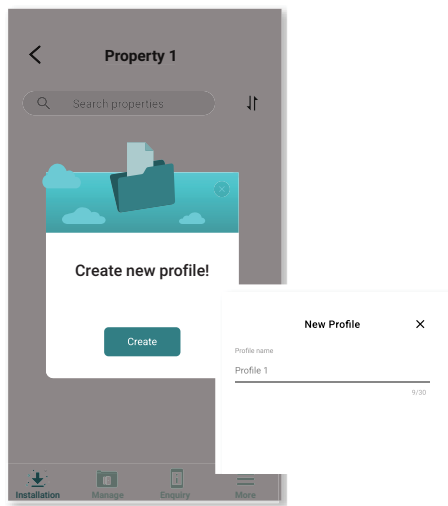

Note

1. Property/profile naming rule: Only numbers, letters and spaces up to 30 characters are allowed.
2. Each property name must be unique and not repeated.
3. Profile names can be duplicated, but must be unique within each property.

3. Tap to select your thermostat's model, W992WZ82, and tap Next.

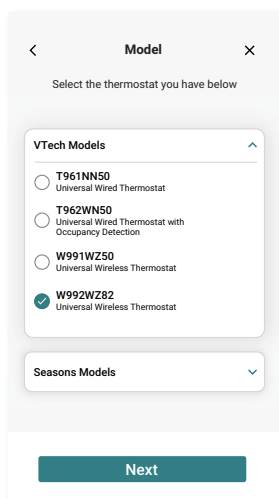

4. Select a wiring system and tap Next, wiring diagram and tap Next, fan speed and tap Next, and review your wiring setup and tap Next.

Note

1. If you do not know the type of HVAC system you will be controlling, please refer to the manufacturer of your HVAC system or contact an authorized HVAC technician.
2. Please consult with your wiring technician to match your choices with the wiring system that will be wired for your thermostat. Selecting an incorrect wiring diagram may damage your system.

5. Tap Create to save this new profile without changing any default settings or values. Or you can define this profile's settings and values on this interface and then tap Create.

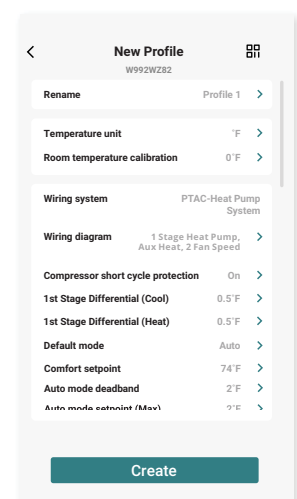

Create Your First Profile

The items in the table below are available in all wiring diagrams

Item	Setting Options or Values	Default Setting or Value
Rename	Fill in the new profile name or ignore this item.	The auto generated profile name or the profile name you have input in Step 2 (e.g., Profile 1).
	<p>Note</p> <ul style="list-style-type: none"> • In this item, you can rename the profile name that you have input in step 2. If you don't want to rename it, just ignore this item. • Only numbers, letters and spaces up to 30 characters are allowed. Padding profile name with ellipsis on this interface if it's too long. • Profile names can be duplicated, but must be unique within each property. 	
Wiring System	<ul style="list-style-type: none"> • PTAC-Conventional System • PTAC-Heat Pump System • Conventional System • Heat Pump System • 2-Pipe FCU System • 4-Pipe FCU System 	The option you have chosen in Step 4.
	<p>Note</p> <ul style="list-style-type: none"> • In this item, you can change your wiring system choice in step 4. If you don't want to change it, just ignore this item. • Please consult with your wiring technician to match your choices with the wiring system that will be wired for your thermostat. Selecting an incorrect wiring system may damage your system. 	
Wiring Diagram	<ul style="list-style-type: none"> • 1 Stage Cool • 2 Stage Cool • 1 Stage Cool, 1 Stage Heat • 1 Stage Cool, 2 Stage Heat • 2 Stage Cool, 1 Stage Heat • 2 Stage Cool, 2 Stage Heat • 2 Stage Cool, 3 Stage Heat • 1 Stage Heat • 2 Stage Heat • 3 Stage Heat • 1 Stage Heat Pump • 1 Stage Heat Pump, Aux Heat • 1 Stage Heat Pump, Emergency Heat • 1 Stage Heat Pump. Emergency Heat, Aux Heat • 2 Stage Heat Pump • 2 Stage Heat Pump, Aux Heat • 2 Stage Heat Pump, Emergency Heat • 2 Stage Heat Pump. Emergency Heat, Aux Heat • 1 Cool or Heat On/Off Valve Actuator • 1 Cool or Heat On/Off Valve Actuator, Electric Heat 	The option you have chosen in Step 4.

Create Your First Profile

The items in the table below are available in all wiring diagrams

Item	Setting Options or Values	Default Setting or Value
Wiring Diagram	<ul style="list-style-type: none"> • 1 Cool and Heat On/Off Valve Actuator • 1 Cool and Heat On/Off Valve Actuator, Electric Heat <p>Note</p> <ul style="list-style-type: none"> • In this item, you can change your wiring diagram choice in step 4. If you don't want to change it, just ignore this item. • Please consult with your wiring technician to match your choices with the wiring diagram that will be wired for your thermostat. Selecting an incorrect wiring diagram may damage your system. 	The option you have chosen in Step 4.
Fan Speed	<ul style="list-style-type: none"> • 1 Fan Speed • 2 Fan Speeds • 3 Fan Speeds <p>Note</p> <ul style="list-style-type: none"> • In this item, you can change your fan speed choice in step 4. If you don't want to change it, just ignore this item. • Please consult with your wiring technician to match your choices with the fan speed that will be wired for your thermostat. Selecting an incorrect fan speed may damage your system. 	The option you have chosen in Step 4.
Changeover Switch	Normally Open (Switch is normally open for hot water) Normally Closed (Switch is normally closed and must be activated for hot water)	Normally Open (Switch is normally open for hot water)
Default Mode	<ul style="list-style-type: none"> • Auto • Heat • Cool <p>Note</p> <p>The default mode will be the primary HVAC mode that is activated each time the system is turned on.</p>	Auto
Humidifier Setpoint	Humidifier Range: 30-95%, RH +/- 5% Dehumidifier Range: 30-95%, RH +/- 5%	Humidifier Default Value: 50% Dehumidifier Default Value: 50%

Create Your First Profile

The items in the table below are available in all wiring diagrams

Item	Setting Options or Values	Default Setting or Value
Override Mode	<ul style="list-style-type: none">• On• Off <p>When set to On, the following options will appear:</p> <ul style="list-style-type: none">• 30 minutes• 45 minutes• 60 minutes• 75 minutes• 90 minutes• 105 minutes• 120 minutes	On
Temperature Unit	<ul style="list-style-type: none">• Fahrenheit (°F)• Celsius (°C) <p>Note The Setpoint Range resets to default values after changing temperature unit.</p>	Fahrenheit (°F)
Comfort Setpoint	Range: 55-82°F (13-28°C)	74°F (23.5°C)
	<p>Note The value of Comfort setpoint is not allowed to be bigger than the maximum cool mode setpoint and smaller than the minimum cool mode setpoint.</p>	
Protection Setpoint	<ul style="list-style-type: none">• On• Off <p>When setting to On, the range of the protection heat setpoint will be 41-48°F (5-9°C), and the range of the protection cool range 90-95°F (32-35°C).</p>	Off <p>When setting to On, the default protection heat setpoint will be 45°F (7°C), and the default protection cool setpoint 90°F (32°C).</p>
Room Temperature Calibration	<ul style="list-style-type: none">• -4°F (-2°C)• -3°F (-1.5°C)• -2°F (-1°C)• -1°F (-0.5°C)• 0°F (0°C)• 1°F (0.5°C)• 2°F (1°C)• 3°F (1.5°C)• 4°F (2°C) <p>Note This allows you to adjust the calibration of the ambient room temperature in order to increase its accuracy and ensure that you're getting a proper temperature reading.</p>	0°F (0°C)

Create Your First Profile

The items in the table below are available in all wiring diagrams

Item	Setting Options or Values	Default Setting or Value
Always-on Display	<ul style="list-style-type: none">• On• Off <p>When setting to On, the following options will appear:</p> <ul style="list-style-type: none">• Level 1 (Min)• Level 2• Level 3 (Max)	Always-on Display: On Automatic Display Dimming: On When set to On, the default is Level 2.
Automatic Display Dimming	<ul style="list-style-type: none">• On• Off	On
Schedule	<ul style="list-style-type: none">• On• Off <p>When setting to On, Create schedule button will appear. Tap Create schedule, select the days of the week and then tap Add block 1 of 4. Set the starting time and temperature and then tap Save.</p> <p>Note Each day of the week must be created with block(s). Otherwise, the schedule's setting cannot be saved.</p>	Off
Filter Change Reminder	<ul style="list-style-type: none">• On• Off <p>When setting to On, the following options will appear:</p> <ul style="list-style-type: none">• 15 days• 30 days• 60 days• 90 days• 120 days• 150 days• 180 days	Off When set to On, the default is 30 days.

Create Your First Profile

The items in the table below are available in all wiring diagrams

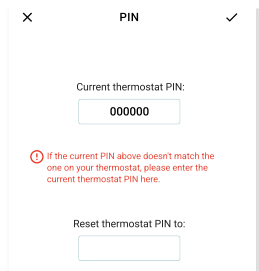
Item	Setting Options or Values	Default Setting or Value
Humidity	<ul style="list-style-type: none">• On• Off	Off
When setting to On, the current room humidity value will be displayed on the screen.		
Daylight Saving Time	<ul style="list-style-type: none">• On• Off	On
Note Daylight savings time (DST), (United States, Canada, and Australia), or summer time (United Kingdom, European Union, and others), is the practice of advancing clocks (typically by one hour) during warmer months so that darkness falls at a later time.		
PIN	Enter your new 6-digit PIN to reset PIN, 000000 or ignore this item to let the current PIN remain unchanged.	
		
Note <ul style="list-style-type: none">• 6 digits are required for a valid PIN.• Both profile and thermostat's default PINs are 000000.• It is allowed to set new PIN identical to current PIN.• Reset thermostat's PIN<ol style="list-style-type: none">1. Enter the thermostat's current and new PINs in this item.2. Install the updated profile on your thermostat.• If you need to upload a profile to a thermostat, enter the current PIN of the thermostat you are setting up in this item. To check your thermostat's current PIN, refer to pages 43 & 45.		
DMS (Device Management Services)	<ul style="list-style-type: none">• On• Off	Off

Create Your First Profile

The items in the table below are only available in some wiring systems:

PTAC-Conventional System | Conventional System

Item	Setting Options or Values	Default Setting or Value
Fan Operation	<ul style="list-style-type: none"> Gas (for system control) Electric (for thermostat control) 	Electric (for system control)

PTAC-Heat Pump System

Item	Setting Options or Values	Default Setting or Value
Changeover Valve	<ul style="list-style-type: none"> Energized in cooling (O) Energized in heating (B) 	Energized in heating (B)

The items in the table below are only available in some wiring diagrams:

1 Stage Cool, 1 Stage Heat | 1 Stage Cool, 1 Stage Heat, Aux Heat | 1 Stage Cool, 2 Stage Heat
2 Stage Cool, 2 Stage Heat | 2 Stage Cool, 2 Stage Heat, Aux Heat

Item	Setting Options or Values	Default Setting or Value
Auto Mode Deadband	<ul style="list-style-type: none"> 2°F (1°C) 4°F (2°C) 6°F (3°C) 8°F (4°C) 10°F (5°C) <p>Note A deadband is a temperature range in which neither heating nor cooling system turns on. The deadband prevents the thermostat from activating heating and cooling in rapid succession. This conserves energy by providing a range of temperatures requiring no energy consumption.</p>	2°F (1°C)
Auto Mode Setpoint (Max)	Range from comfort setpoint +1 to 89°F (31.5°C).	80°F (26.5°C)
Auto Mode Setpoint (Min)	Range from comfort setpoint -1 to 49°F (9.5°C).	65°F (18.5°C)
<p>Note - Example of Auto Mode Setpoint If the comfort setpoint is set to the default value 74°F (23.5°C), the maximum auto mode setpoint range is 75-89°F (24-31.5°C), and the minimum auto mode setpoint range is 49-73°F (9.5-23°C).</p>		

Create Your First Profile

The items in the table below are only available in some wiring diagrams:

1 Stage Cool	1 Stage Cool, 1 Stage Heat	1 Stage Cool, 1 Stage Heat, Aux Heat
1 Stage Cool, 2 Stage Heat	2 Stage Cool, 2 Stage Heat	2 Stage Cool, 2 Stage Heat, Aux Heat
2 Stage Cool	2 Stage Cool, 1 Stage Heat	2 Stage Cool, 3 Stage Heat
1 Cool or 1 Heat On/Off Valve Actuator	1 Cool or 1 Heat On/Off Valve Actuator, Electric Heat	1 Cool and 1 Heat On/Off Valve Actuator
1 Cool and 1 Heat On/Off Valve Actuator, Electric Heat		

Item	Setting Options or Values	Default Setting or Value
Compressor Short Cycle	<ul style="list-style-type: none"> On Off Options when setting to On: <ul style="list-style-type: none"> 3 minutes 4 minutes 5 minutes 	On - 3 minutes
Cool Mode Setpoint (Max)	Range from comfort setpoint +1 to 89°F (31.5°C).	77°F (25°C)
Cool Mode Setpoint (Min)	Range from comfort setpoint -1 to 49°F (9.5°C).	64°F (18°C)
1 st Stage Differential (Cool)	<ul style="list-style-type: none"> 0.5°F (0.25°C) 1°F (0.5°C) 1.5°F (0.75°C) 	0.5°F (0.25°C)
<p>Note - 1st Stage Differential (Cool) 1st Stage Differential (Cool) - determines the level of control and consequently the cycle rate. Adjustable between 0.5°F (0.25°C) and 1.5°F (0.75°C), this is the value above the set point that the temperature must rise to start the cooling. It is also the value below the set point that the temperature must fall for the cooling to stop.</p>		
2 nd Stage Differential (Cool)	<ul style="list-style-type: none"> 1°F (0.5°C) 2°F (1°C) 	2°F (1°C)
<p>Note - 2nd Stage Differential (Cool) Adjustable between 1°F (0.5°C) and 2°F (1°C), this also determines the level of control by determining when to use the 2nd stage of cooling. It can also be used to keep 2nd stage cooling from coming on too soon when 1st stage is acting to control temperature levels.</p>		

Create Your First Profile

The items in the table below are only available in some wiring diagrams:

1 Stage Cool, 1 Stage Heat	1 Stage Cool, 1 Stage Heat, Aux Heat	1 Stage Cool, 2 Stage Heat
2 Stage Cool, 2 Stage Heat	2 Stage Cool, 2 Stage Heat , Aux Heat	1 Stage Heat
2 Stage Heat	2 Stage Cool, 1 Stage Heat	2 Stage Cool, 3 Stage Heat
3 Stage Heat	1 Stage Heat Pump, Emergency Heat	2 Stage Heat Pump, Emergency Heat
1 Cool or 1 Heat On/Off Valve Actuator	1 Cool or 1 Heat On/Off Valve Actuator, Electric Heat	1 Cool and 1 Heat On/Off Valve Actuator
1 Cool and 1 Heat On/Off Valve Actuator, Electric Heat		

Item	Setting Options or Values	Default Setting or Value
1 st Stage Differential (Heat)	<ul style="list-style-type: none"> • 0.5°F (0.25°C) • 1°F (0.5°C) • 1.5°F (0.75°C) <p>Note - 1st Stage Differential (Heat) Determines the level of control and consequently the cycle rate. Adjustable between 0.5°F (0.25°C) and 1.5°F (0.25°C), this is the value below the set point that the temperature must fall to start the heating. It is also the value above the set point that the temperature must rise for the heating to stop.</p>	0.5°F (0.25°C)
2 nd Stage Differential (Heat)	<ul style="list-style-type: none"> • 1°F (0.5°C) • 2°F (1°C) <p>Note - 2nd Stage Differential (Heat) Adjustable between 1°F (0.5°C) and 2°F (1°C), this also determines the level of control by determining when to use the 2nd stage of heating. It can also be used to keep 2nd stage heating from coming on too soon when 1st stage is acting to control temperature levels or to keep costly auxiliary heat from coming on too soon when the heat pump is sufficient.</p>	2°F (1°C)
3 rd Stage Differential (Heat)	<ul style="list-style-type: none"> • 1°F (0.5°C) • 2°F (1°C) 	2°F (1°C)
Heat Mode Setpoint (Max)	Range from comfort setpoint +1 to 89°F (31.5°C).	80°F (26.5°C)
Heat Mode Setpoint (Min)	Range from comfort setpoint -1 to 49°F (9.5°C).	65°F (18.5°C)

Note - Example of Heat Mode Setpoint

If the comfort setpoint is set to the default value 74°F (23.5°C), the maximum heat mode setpoint range is 75-89°F (24-31.5°C), and the minimum heat mode setpoint range is 49-73°F (9.5-23°C).