

TEST REPORT

Report No.: 23081166HKG-005R1

VTech Telecommunications Ltd.

Application For Original Grant of 47 CFR Part 15 Certification

New Family of RSS-247 Issue 3 Certification

Thermostat

FCC ID: EW780-T118-00

IC: 1135B-80T11800

This report supersedes previous report with report number 24081166HKG-005 dated March 03, 2025

Prepared and Checked by:

Approved by:

Signed on File

Leung Chun Ning, Peter
Engineer

Wong Cheuk Ho, Herbert
Assistant Manager
Date: June 04, 2025

Intertek's standard Terms and Conditions can be obtained at our website <http://www.intertek.com/terms/>.

The test report only allows to be revised within the retention period unless further standard or the requirement was noticed.

This report is for the exclusive use of Intertek's Client and is provided pursuant to the agreement between Intertek and its Client. Intertek's responsibility and liability are limited to the terms and conditions of the agreement. Intertek assumes no liability to any party, other than to the Client in accordance with the agreement, for any loss, expense or damage occasioned by the use of this report. Only the Client is authorized to permit copying or distribution of this report and then only in its entirety. Any use of the Intertek name or one of its marks for the sale or advertisement of the tested material, product or service must first be approved in writing by Intertek. The observations and test results in this report are relevant only to the sample tested. This report by itself does not imply that the material, product, or service is or has ever been under an Intertek certification program.

© 2017 Intertek

TEST REPORT

GENERAL INFORMATION

Grantee:	VTech Telecommunications Ltd.
Grantee Address:	23/F., Tai Ping Industrial Centre, Block 1, 57 Ting Kok Road, Tai Po, Hong Kong.
Manufacturer Name:	VTech (Dongguan) Telecommunications Limited
Manufacturer Address:	VTech Science Park, Xia Ling Bei Management Zone, Liaobu, Dongguan, Guangdong, China.
FCC Specification Standard:	FCC Part 15, October 1, 2023 Edition
FCC ID:	EW780-T118-00
FCC Model(s):	W992WZ82, SW992WZ50, SW991WZ50
IC Specification Standard:	RSS-247 Issue 3, August 2023 RSS-Gen Issue 5 Amendment 2, February 2021
IC:	1135B-80T11800
HVIN:	35-400588T
PMN:	W992WZ82, SW992WZ50, SW991WZ50
Type of EUT:	Spread Spectrum Transmitter
Description of EUT:	Thermostat
Brand Name:	VTech, Seasons
Sample Receipt Date:	August 30, 2024
Date of Test:	August 30, 2024 to October 30, 2024
Report Date:	March 03, 2025
Environmental Conditions:	Temperature: +10 to 40°C Relative Humidity: 10 to 90%
Conclusion:	Test was conducted by client submitted sample. The submitted sample as received complied with the 47 CFR Part 15 / RSS-247 Issue 3 Certification.

AMENDMENT HISTORY

Report No.	Issue Date	Content
24081166HKG-005	March 03, 2025	Original Report
24081166HKG-005R1	June 04, 2025	Revised Model Differences

TEST REPORT

SUMMARY OF TEST RESULT

Test Items	FCC Part 15 Section	RSS-247 / RSS-Gen# Section	Results
Antenna Requirement	15.203	7.1.2 [#]	Complied
Max. Conducted Output Power (Peak)	15.247(b)(3)&(4)	5.4(4)	Complied
Min. 6dB RF Bandwidth	15.247(a)(2)	5.2(1)	Complied
Max. Power Density (Average)	15.247(e)	5.2(2)	Complied
Out of Band Antenna Conducted Emission	15.247(d)	5.5	Complied
Radiated Emission in Restricted Bands and Spurious Emissions	15.247(d), 15.209 & 15.109	5.5	Complied
AC Power Line Conducted Emission	15.207 & 15.107	7.2.4 [#]	Complied

Note: Pursuant to FCC Part 15 Section 15.215(c), the 20dB bandwidth of the emission was contained within the frequency band designated (mentioned as above) which the EUT operated. The effects, if any, from frequency sweeping, frequency hopping, other modulation techniques and frequency stability over expected variations in temperature and supply voltage were considered.

For all technical data, which can be referred to Annex B – Report cover sheet.

For electronic filing, the Annex B – Report cover sheet is saved with filename: Annex B.pdf.

The equipment under test is found to be complying with the following standards:

FCC Part 15, October 1, 2023 Edition

RSS-247 Issue 3, August 2023

RSS-Gen Issue 5 Amendment 2, February 2021

TEST REPORT

TABLE OF CONTENTS

EXHIBIT 1	GENERAL DESCRIPTION	5
1.1	Product Description	5
1.2	Test Methodology	5
1.3	Test Facility.....	5
1.4	Related Submittal(s) Grants	5
EXHIBIT 2	SYSTEM TEST CONFIGURATION	6
2.1	Justification	6
2.2	EUT Exercising Software.....	7
2.3	Description of Accessories	8
2.4	Measurement Uncertainty.....	8
EXHIBIT 3	TEST RESULTS.....	9
3.1	Maximum Conducted (Peak) Output Power at Antenna Terminals.....	9
3.2	Minimum 6dB RF Bandwidth	11
3.3	Minimum Power Spectral Density	12
3.4	Out of Band Conducted Emissions.....	13
3.5	Field Strength Calculation	14
3.6	Transmitter Radiated Emissions in Restricted Bands and Spurious Emissions	15
3.7	Transmitter Duty Cycle Calculation	21
3.8	AC Power Line Conducted Emission	21
EXHIBIT 4	EQUIPMENT LIST	24

TEST REPORT

EXHIBIT 1 GENERAL DESCRIPTION

1.1 Product Description

The W992WZ82 (35-400588T) is a Thermostat.

The Equipment Under Test (EUT) operates at frequency range of 2405 MHz to 2480 MHz with 16 channels, the channels are separated with 5MHz spacing.

The EUT is powered by 3 x 1.5V AA batteries or 24VAC.

The antenna(s) used in the EUT is integral, and the test sample is a prototype.

Peak Antenna Gain: 0dBi

The difference in model number represent the following as declared by client:

Models	Description
W992WZ82	Fully popularize
SW992WZ50	Removed 3 relays and digital/analog control terminals at Thermostat Controller; Removed light sensor at Thermostat
SW991WZ50	Removed 3 relays and digital/analog control terminals at Thermostat Controller; Removed buzzer; light sensor, PIR sensor, change touch buttons to hard button (on board) at Thermostat

The representative model(s) W992WZ82 was selected to test.

The circuit description is saved with filename: descri.pdf.

1.2 Test Methodology

Both AC power line-conducted and radiated emission measurements were performed according to the procedures in ANSI C63.10 (2013). Preliminary radiated scans and all radiated measurements were performed in radiated emission test sites. All Radiated tests were performed at an antenna to EUT distance of 3 meters, unless stated otherwise in the "**Justification Section**" of this Application.

Antenna port conducted measurements were performed according to ANSI C63.10 (2013) and KDB Publication No. 558074 D01 v05r02 (April 02, 2019) All other measurements were made in accordance with the procedures in 47 CFR Part 2 and RSS-Gen Issue 5 Amendment 2, February 2021.

1.3 Test Facility

The radiated emission test site and antenna port conducted measurement facility used to collect the radiated data and conductive data are at Workshop No. 3, G/F., World-Wide Industrial Centre, 43-47 Shan Mei Street, Fo Tan, Sha Tin, N.T., Hong Kong SAR, China. This test facility and site measurement data have been fully placed on file with the FCC and Industry Canada No.: 2042H, CABID is "HKAP01".

1.4 Related Submittal(s) Grants

This is a single application for certification of a transceiver (Zigbee Portion).

TEST REPORT

EXHIBIT 2 SYSTEM TEST CONFIGURATION

2.1 Justification

For radiated emissions testing, the equipment under test (EUT) was setup to transmit / receive continuously to simplify the measurement methodology. Care was taken to ensure proper power supply voltages during testing. During testing, all cables (if any) were manipulated to produce worst case emissions.

The EUT was powered by 4.5VDC (3 x 1.5V AA Batteries) or 24VAC during test.

For the measurements, the EUT was attached to a plastic stand if necessary and placed on the wooden turntable at 0.8m height from the ground plane for emission testing at or below 1GHz and 1.5m for emission measurements above 1GHz. If the EUT attached to peripherals, they were connected and operational (as typical as possible).

The signal was maximized through rotation and placement in the three orthogonal axes. The antenna height and polarization were varied during the search for maximum signal level. The antenna height was varied from 1 to 4 meters. Radiated emissions were taken at three meters unless the signal level was too low for measurement at that distance. If necessary, a pre-amplifier was used and/or the test was conducted at a closer distance.

For any intentional radiator powered by AC power line, measurements of the radiated signal level of the fundamental frequency component of the emission was performed with the supply voltage varied between 85% and 115% of the nominal rated supply voltage.

Radiated emission measurement for transmitter were performed from the lowest radio frequency signal generated in the device which is greater than 9 kHz to the tenth harmonic of the highest fundamental frequency or to 40 GHz, whichever is lower.

Emission that are directly caused by digital circuits in the transmit path and transmitter portion were measured, and the limit are according to FCC Part 15 Section 15.209 / RSS-247 2.5. Digital circuitries used to control additional functions other than the operation of the transmitter are subject to FCC Part 15 Section 15.109 / RSS-247 Section 5.5 Limits.

TEST REPORT

2.1 Justification (Cont'd)

Detector function for radiated emissions was in peak mode. Average readings, when required, were taken by measuring the duty cycle of the equipment under test and subtracting the corresponding amount in dB from the measured peak readings. A detailed description for the calculation of the average factor can be found in section 4.8.3.

Determination of pulse desensitization was made according to *Hewlett Packard Application Note 150-2, Spectrum Analysis... Pulsed RF*. The effective period (Teff) was referred to Exhibit 4.8.3. With the resolution bandwidth 1MHz and spectrum analyzer IF bandwidth 3dB, the pulse desensitization factor was 0dB.

For AC power line-conducted emission test, the EUT along with its peripherals were placed on a 1.0m(W)x1.5m(L) and 0.8m in height wooden table and the EUT was adjusted to maintain a 0.4 meter space from a vertical reference plane. The EUT was connected to power mains through a line impedance stabilization network (LISN), which provided 50ohm coupling impedance for measuring instrument. The LISN housing, measuring instrument case, reference ground plane, and vertical ground plane were bounded together. The excess power cable between the EUT and the LISN was bundled.

All connecting cables of EUT and peripherals were manipulated to find the maximum emission.

Different data rates have been tested. Worst case is reported only.

All relevant operation modes have been tested, and the worst-case data is included in this report.

2.2 EUT Exercising Software

The EUT exercise program (SSCOM V5.13.1) used during radiated and conducted testing was designed to exercise the various system components in a manner similar to a typical use.

TEST REPORT

2.3 Description of Accessories

Description	Remark
24V Transformer	Provided by Intertek

2.4 Measurement Uncertainty

Decision Rule for compliance: For FCC/IC standard, the measured value must be within the limits of applicable standard without accounting for the measurement uncertainty. For EN/IEC/HKTA/HKTC standard, conformity rules will be used as per standard directly excepted EN/IEC 61000-3-2, EN/IEC 61000-3-3, HKTA1004, HKCA1008, HKTA1019, HKTA1020, HKTA1041 and HKTA1044.

Uncertainty and Compliance - Unless the standard specifically states that measured values are to be extended by the measurement uncertainty in determining compliance, all compliance determinations are based on the actual measured value.

TEST REPORT

EXHIBIT 3 TEST RESULTS

3.1 Maximum Conducted (Peak) Output Power at Antenna Terminals

RF Conduct Measurement Test Setup

The figure below shows the test setup, which is utilized to make these measurements.

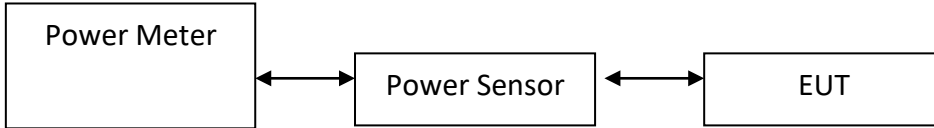

The antenna port of the EUT was connected to the input of a spectrum analyzer.

- The antenna power of the EUT was connected to the input of a power meter. Power was read directly and cable loss correction was added to the reading to obtain power at the EUT antenna terminals. The measurement procedure 8.3.2.3 was used.
- The EUT should be configured to transmit continuously (at a minimum duty cycle of 98%) at full power over the measurement duration. The measurement procedure AVG1 was used.

Peak Antenna Gain = 0 dBi

Frequency (MHz)	Output in dBm	Output in mW
Low Channel: 2405	9.73	9.40
Middle Channel: 2440	9.62	9.16
High Channel: 2480	8.87	7.71

TEST REPORT

3.1 Maximum Conducted (Peak) Output Power at Antenna Terminals (Cont'd)

Cable loss: 0.5 dB External Attenuation: 0 dB

Cable loss, external attenuation: included in OFFSET function
 added to SA raw reading

Max. Conducted (Peak) Output Level = 9.73 dBm

Limits:

1W (30dBm) for antennas with gains of 6dBi or less.

TEST REPORT**3.2 Minimum 6dB RF Bandwidth**

The figure below shows the test setup, which is utilized to make these measurements.

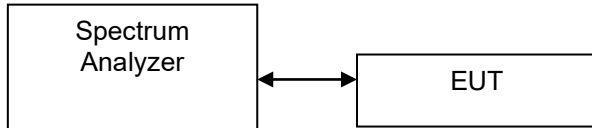

The antenna port of the EUT was connected to the input of a spectrum analyzer. The EBW measurement procedure was used. A PEAK output reading was taken, a DISPLAY line was drawn 6dB lower than PEAK level. The 6dB bandwidth was determined from where the channel output spectrum intersected the display line.

(Refer to Test Data.pdf)

Frequency (MHz)	6dB Bandwidth (MHz)
Low Channel: 2405 (P.4)	1.650
Middle Channel: 2440 (P.17)	1.650
High Channel: 2480 (P.25)	1.650

Limits:

6dB bandwidth shall be at least 500kHz.

TEST REPORT**3.3 Minimum Power Spectral Density**

The figure below shows the test setup, which is utilized to make these measurements.

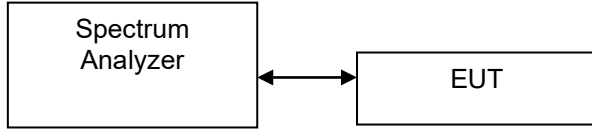

Antenna output of the EUT was coupled directly to spectrum analyzer. The measurement procedure 10.2 PKPSD was used. If an external attenuator and/or cable was used, these losses are compensated for using the OFFSET function of the analyser.

(Refer to Test Data.pdf)

Frequency (MHz)	PSD in 100kHz (dBm)
Low Channel: 2405 (P.7)	4.800
Middle Channel: 2440 (P.18)	0.006
High Channel: 2480 (P.26)	-1.071

Cable Loss: 0.5dB

Limit: 8dBm in 3kHz

TEST REPORT

3.4 Out of Band Conducted Emissions

The figure below shows the test setup, which is utilized to make these measurements.

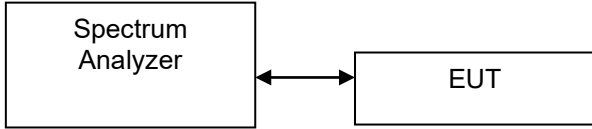

The maximum conducted (peak) output power was used to demonstrate compliance as described in 9.1. Then the display line (in red) shown in the following plots denotes the limit at 20dB below maximum measured in-band peak PSD level in 100 KHz bandwidth.

The measurement procedures under sections 11 of KDB558074 D01 v05r02 (April 2, 2019) were used.

Furthermore, delta measurement technique for measuring bandedge emissions was incorporated in the test of the edge at 2483.5MHz.

Limits:

All spurious emission and up to the tenth harmonic was measured and they were found to be at least 20dB below the maximum measured in-band peak PSD level.

(Refer to Test Data.pdf)

Frequency (MHz)	Out of Band Conducted Emissions	Band Edge
Low Channel: 2405	P.12	P.8
Middle Channel: 2440	P.20	N/A
High Channel: 2480	P.31	P.27

TEST REPORT

3.5 Field Strength Calculation

The field strength is calculated by adding the reading on the Spectrum Analyzer to the factors associated with preamplifiers (if any), antennas, cables, pulse desensitization and average factors (when specified limit is in average and measurements are made with peak detectors). A sample calculation is included below.

$$FS = RA + AF + CF - AG + PD + AV$$

Where	FS	=	Field Strength in dB μ V/m
	RA	=	Receiver Amplitude (including preamplifier) in dB μ V
	CF	=	Cable Attenuation Factor in dB
	AF	=	Antenna Factor in dB
	AG	=	Amplifier Gain in dB
	PD	=	Pulse Desensitization in dB
	AV	=	Average Factor in -dB

In the radiated emission table which follows, the reading shown on the data table may reflect the preamplifier gain. An example of the calculations, where the reading does not reflect the preamplifier gain, follows:

$$FS = RA + AF + CF - AG + PD + AV$$

Example:

Assume a receiver reading of 62.0 dB μ V is obtained. The antenna factor of 7.4 dB and cable factor of 1.6 dB is added. The amplifier gain of 29.0 dB is subtracted. The pulse desensitization factor of the spectrum analyzer is 0.0 dB, and the resultant average factor is -10.0 dB. The net field strength for comparison to the appropriate emission limit is 32.0 dB μ V/m. This value in dB μ V/m is converted to its corresponding level in μ V/m.

RA	=	62.0 dB μ V
AF	=	7.4 dB
CF	=	1.6 dB
AG	=	29.0 dB
PD	=	0.0 dB
AV	=	-10.0 dB
FS	=	$62.0 + 7.4 + 1.6 - 29.0 + 0.0 + -10.0 = 32.0$ dB μ V/m

$$\text{Level in } \mu\text{V/m} = \text{Common Antilogarithm } [(32.0 \text{ dB}\mu\text{V/m})/20] = 39.8 \mu\text{V/m}$$

TEST REPORT

3.6 Transmitter Radiated Emissions in Restricted Bands and Spurious Emissions

Data is included of the worst-case configuration (the configuration which resulted in the highest emission levels). A sample calculation, configuration photographs and data tables of the emissions are included.

The data on the following pages list the significant emission frequencies, the limit and the margin of compliance.

3.6.1 Radiated Emission Configuration Photograph

Worst Case Restricted Band Radiated Emission at 7440 MHz.

The worst case radiated emission configuration photographs are saved with filename:
Setup Photos.pdf

3.6.2 Radiated Emission Data

The data in tables 1-4 list the significant emission frequencies, the limit and the margin of compliance.

Judgement – Passed by 0.3 dB margin

TEST REPORT

3.6.3 Radiated Emission Test Setup

The figure below shows the test setup, which is utilized to make these measurements.

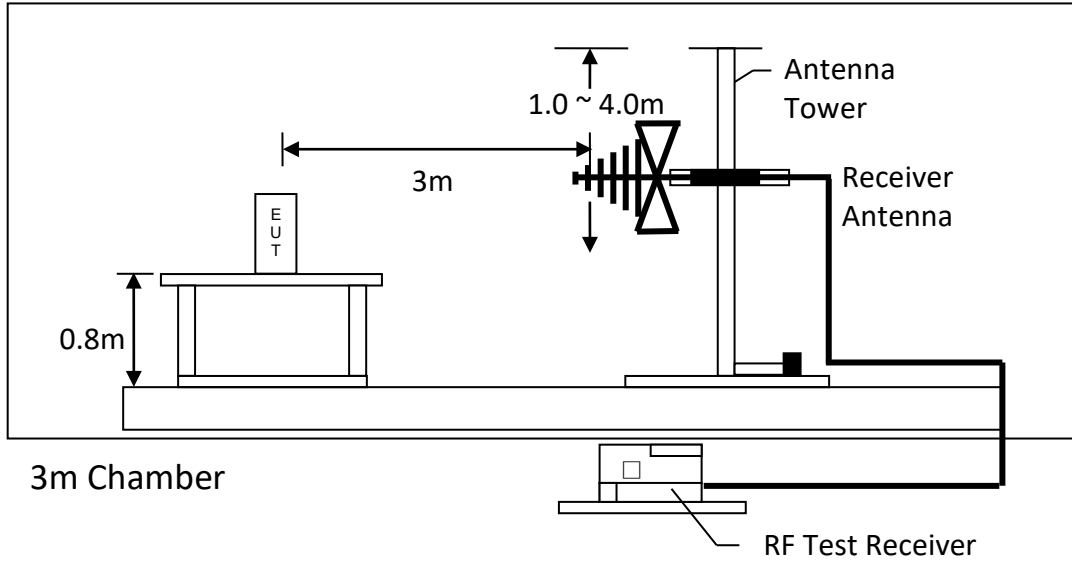

Test setup of radiated emissions up to 1GHz

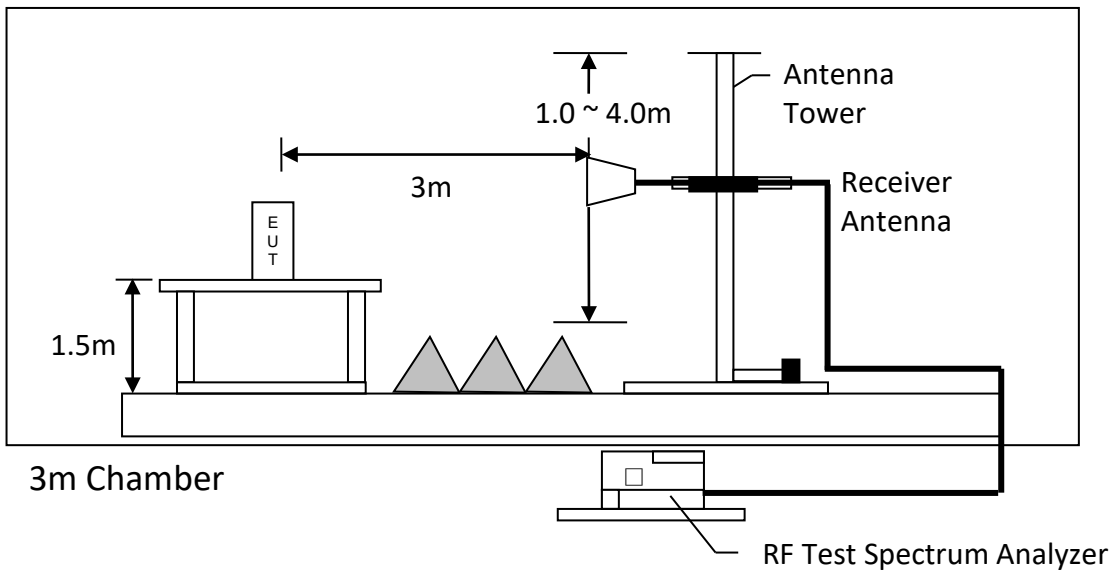

Test setup of radiated emissions above 1GHz

TEST REPORT

RADIATED EMISSION DATA

Mode: TX-Channel 2405MHz (Zigbee)

Table 1

Polarization	Frequency (MHz)	Reading (dB μ V)	Pre-Amp Gain (dB)	Antenna Factor (dB)	Net at 3m (average) (dB μ V/m)	Average Limit at 3m (dB μ V/m)	Margin (dB)
H	2390.000	36.1	33	29.4	32.5	54.0	-21.5
V	4810.000	47.5	33	34.9	49.4	54.0	-4.6
V	7215.000	43.1	33	37.9	48.0	54.0	-6.0
V	9620.000	36.2	33	40.4	43.6	54.0	-10.4
V	12025.000	38.7	33	40.5	46.2	54.0	-7.8
H	14430.000	43.5	33	40.0	50.5	54.0	-3.5

Polarization	Frequency (MHz)	Reading (dB μ V)	Pre-Amp Gain (dB)	Antenna Factor (dB)	Net at 3m - Peak (dB μ V/m)	Peak Limit at 3m (dB μ V/m)	Margin (dB)
H	2390.000	64.5	33	29.4	60.9	74.0	-13.1
V	4810.000	59.9	33	34.9	61.8	74.0	-12.2
V	7215.000	56.7	33	37.9	61.6	74.0	-12.4
V	9620.000	50.3	33	40.4	57.7	74.0	-16.3
V	12025.000	52.6	33	40.5	60.1	74.0	-13.9
H	14430.000	60.2	33	40.0	67.2	74.0	-6.8

- Notes:
1. Peak detector is used for the emission measurement.
 2. Average detector is used for the average data of emission measurement.
 3. All measurements were made at 3 meters.
 4. Negative value in the margin column shows emission below limit.
 5. Horn antenna is used for the emission over 1000MHz.
 6. Emissions within the restricted band meets the requirement of FCC Part 15 Section 15.205 / RSS-Gen Section 8.10.
 7. Measurement Uncertainty is ± 5.3 dB at a level of confidence of 95%.
 8. For the measurement of radiated emission, summation method was used which numerical integrating (in terms of linear power) over the transmitter occupied bandwidth.
 9. For the linear power measurement, data in 1MHz spacing was collected by spectrum analyzer with 1MHz resolution bandwidth.

TEST REPORT

RADIATED EMISSION DATA

Mode: TX-Channel 2440 (Zigbee)

Table 2

Polarization	Frequency (MHz)	Reading (dB μ V)	Pre-Amp Gain (dB)	Antenna Factor (dB)	Net at 3m (average) (dB μ V/m)	Average Limit at 3m (dB μ V/m)	Margin (dB)
V	4880.000	47.0	33	34.9	48.9	54.0	-5.1
V	7320.000	44.1	33	37.9	49.0	54.0	-5.0
V	9760.000	35.5	33	40.4	42.9	54.0	-11.1
V	12200.000	38.6	33	40.5	46.1	54.0	-7.9
H	14640.000	39.0	33	38.4	44.4	54.0	-9.6

Polarization	Frequency (MHz)	Reading (dB μ V)	Pre-Amp Gain (dB)	Antenna Factor (dB)	Net at 3m - Peak (dB μ V/m)	Peak Limit at 3m (dB μ V/m)	Margin (dB)
V	4880.000	59.6	33	34.9	61.5	74.0	-12.5
V	7320.000	58.7	33	37.9	63.6	74.0	-10.4
V	9760.000	49.1	33	40.4	56.5	74.0	-17.5
V	12200.000	51.7	33	40.5	59.2	74.0	-14.8
H	14640.000	52.1	33	38.4	57.5	74.0	-16.5

- Notes:
1. Peak detector is used for the emission measurement.
 2. Average detector is used for the average data of emission measurement.
 3. All measurements were made at 3 meters.
 4. Negative value in the margin column shows emission below limit.
 5. Horn antenna is used for the emission over 1000MHz.
 6. Emissions within the restricted band meets the requirement of FCC Part 15 Section 15.205 / RSS-Gen Section 8.10.
 7. Measurement Uncertainty is ± 5.3 dB at a level of confidence of 95%.
 8. For the measurement of radiated emission, summation method was used which numerical integrating (in terms of linear power) over the transmitter occupied bandwidth.
 9. For the linear power measurement, data in 1MHz spacing was collected by spectrum analyzer with 1MHz resolution bandwidth.

TEST REPORT

RADIATED EMISSION DATA

Mode: TX-Channel 2480 (Zigbee)

Table 3

Polarization	Frequency (MHz)	Reading (dB μ V)	Pre-Amp Gain (dB)	Antenna Factor (dB)	Net at 3m (average) (dB μ V/m)	Average Limit at 3m (dB μ V/m)	Margin (dB)
H	2483.500	44.1	33	29.4	40.5	54.0	-13.5
V	4960.000	50.2	33	34.9	52.1	54.0	-1.9
V	7440.000	48.8	33	37.9	53.7	54.0	-0.3
V	9920.000	37.6	33	40.4	45.0	54.0	-9.0
V	12400.000	43.0	33	40.5	50.5	54.0	-3.5
H	14880.000	38.6	33	38.4	44.0	54.0	-10.0

Polarization	Frequency (MHz)	Reading (dB μ V)	Pre-Amp Gain (dB)	Antenna Factor (dB)	Net at 3m - Peak (dB μ V/m)	Peak Limit at 3m (dB μ V/m)	Margin (dB)
H	2483.500	72.9	33	29.4	69.3	74.0	-4.7
V	4960.000	62.5	33	34.9	64.4	74.0	-9.6
V	7440.000	61.6	33	37.9	66.5	74.0	-7.5
V	9920.000	51.2	33	40.4	58.6	74.0	-15.4
V	12400.000	56.8	33	40.5	64.3	74.0	-9.7
H	14880.000	52.3	33	38.4	57.7	74.0	-16.3

- Notes:
1. Peak detector is used for the emission measurement.
 2. Average detector is used for the average data of emission measurement.
 3. All measurements were made at 3 meters.
 4. Negative value in the margin column shows emission below limit.
 5. Horn antenna is used for the emission over 1000MHz.
 6. Emissions within the restricted band meets the requirement of FCC Part 15 Section 15.205 / RSS-Gen Section 8.10.
 7. Measurement Uncertainty is ± 5.3 dB at a level of confidence of 95%.
 8. For the measurement of radiated emission, summation method was used which numerical integrating (in terms of linear power) over the transmitter occupied bandwidth.
 9. For the linear power measurement, data in 1MHz spacing was collected by spectrum analyzer with 1MHz resolution bandwidth.

TEST REPORT

RADIATED EMISSION DATA

Mode: Zigbee and NFC tag Operating

Table 4

Polarization	Frequency (MHz)	Reading (dB μ V)	Pre-amp (dB)	Antenna Factor (dB)	Net at 3m (dB μ V/m)	Limit at 3m (dB μ V/m)	Margin (dB)
V	69.043	19.9	16	7.0	10.9	40.0	-29.1
V	95.718	21.1	16	12.0	17.1	43.5	-26.4
V	148.098	16.1	16	14.0	14.1	43.5	-29.4
V	210.178	12.9	16	17.0	13.9	43.5	-29.6
H	249.948	15.0	16	20.0	19.0	46.0	-27.0
H	624.974	16.8	16	29.0	29.8	46.0	-16.2

- Notes:
1. Peak detector is used for the emission measurement.
 2. All measurements were made at 3 meters.
 3. Negative value in the margin column shows emission below limit.
 4. Emissions within the restricted band meets the requirement of FCC Part 15 Section 15.205 / RSS-Gen Section 8.10.
 5. Measurement Uncertainty is ± 5.3 dB at a level of confidence of 95%.

TEST REPORT

3.7 Transmitter Duty Cycle Calculation

Not Applicable – No average factor is required

3.8 AC Power Line Conducted Emission

- Not Applicable – EUT is only powered by battery for operation.
- EUT connects to AC power line. Emission Data is listed in following pages.
- Base Unit connects to AC power line and has transmission. Handset connects to AC power line but has no transmission. Emission Data of Base Unit is listed in following pages.

3.8.1 AC Power Line Conducted Emission Configuration Photograph

The worst-case line conducted configuration photographs are attached in the Appendix and saved with filename: Setup Photos.pdf.

3.8.2 AC Power Line Conducted Emission Data

The plot(s) and data in the following pages list the significant emission frequencies, the limit and the margin of compliance.

Passed by over 20 dB margin

3.8.3 Conducted Emission Test Setup

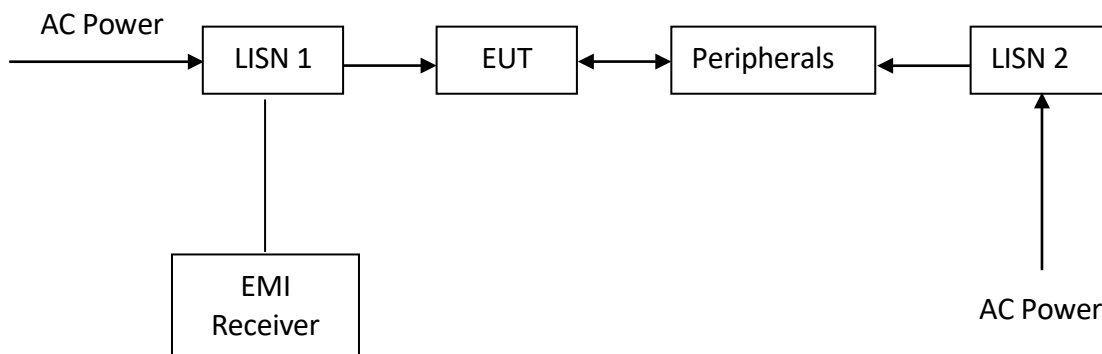

The EUT along with its peripherals were placed on a 1.0m(W)×1.5m(L) and 0.8m in height wooden table and the EUT was adjusted to maintain a 0.4 meter space from a vertical reference plane. The EUT was connected to power mains through a line impedance stabilization network (LISN), which provided 50 ohm coupling impedance for measuring instrument and the chassis ground was bounded to the horizontal ground plane of shielded room. The excess power cable between the EUT and the LISN was bundled.

All connecting cables of EUT and peripherals were moved to find the maximum emission.

TEST REPORT

AC POWER LINE CONDUCTED EMISSION

Worst Case: Zigbee and NFC tag Operating



RBW 9 kHz
MT 20 ms

Att 10 dB AUTOC PREAMP OFF

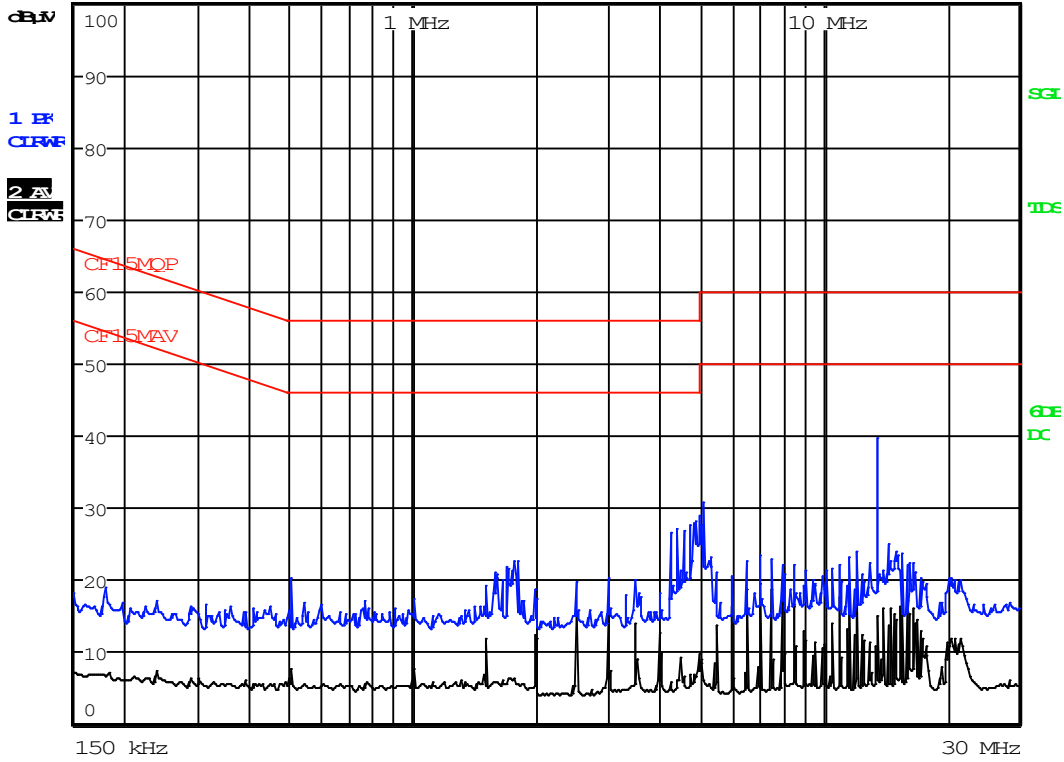

TEST REPORT

OCCUPIED BANDWIDTH

The figure below shows the test setup, which is utilized to make these measurements.

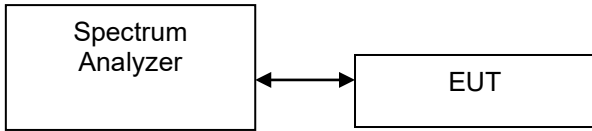

Occupied Bandwidth Results: (Refer to Test Data.pdf)

Frequency (MHz)	Occupied Bandwidth (MHz)
Low Channel: 2405 (P.5)	2.340
Middle Channel: 2440 (P.15)	2.280
High Channel: 2480 (P.23)	2.295

TEST REPORT

EXHIBIT 4 EQUIPMENT LIST

1) Radiated Emissions Test

Equipment	EMI Test Receiver (9kHz to 26.5GHz)	Biconical Antenna (30MHz to 300MHz)	Log Periodic Antenna
Registration No.	EW-3156	EW-3242	EW-3243
Manufacturer	ROHDESCHWARZ	EMCO	EMCO
Model No.	ESR26	3110C	3148B
Calibration Date	January 31, 2024	July 30, 2024	July 30, 2024
Calibration Due Date	January 31, 2025	July 30, 2026	January 30, 2026

Equipment	Double Ridged Guide Antenna (1GHz - 18GHz)	Active Loop Antenna (H-field) (9kHz to 30MHz)	RF Pre-amplifier (9kHz to 6000MHz)
Registration No.	EW-0194	EW-3326	EW-3006b
Manufacturer	EMCO	EMCO	SCHWARZBECK
Model No.	3115	6502	BBV9718
Calibration Date	May 10, 2023	January 05, 2024	October 20, 2023
Calibration Due Date	November 10, 2024	July 05, 2025	January 20, 2025

Equipment	2.4GHz Notch Filter	14m Double Shield RF Cable (9kHz - 6GHz)	RF Cable 14m (1GHz to 26.5GHz)
Registration No.	EW-3435	EW-2376	EW-2781
Manufacturer	MICROWAVE	RADIALL	GREATBILLION
Model No.	N0324413	n m/br56/bnc m 14m	SMA m/SHF5MPU /SMA m ra14m,26G
Calibration Date	September 26, 2023	September 19, 2023	January 16, 2024
Calibration Due Date	December 26, 2024	December 19, 2024	January 16, 2025

Equipment	12 metre RF Cable (1-40)GHz	Pyramidal Horn Antenna
Registration No.	EW-2774	EW-0905
Manufacturer	GREATBILLION	EMCO
Model No.	SMA m-m ra 12m 40G outdoor	3160-09
Calibration Date	January 16, 2024	December 15, 2023
Calibration Due Date	January 16, 2025	June 15, 2025

TEST REPORT

EXHIBIT 4 EQUIPMENT LIST (CONT'D)

2) Conducted Emissions Test

Equipment	RF Cable 240cm (RG142) - (9kHz to 30MHz)	Artificial Mains Network	EMI Test Receiver (9kHz to 3GHz)
Registration No.	EW-2454	EW-3360	EW-3095
Manufacturer	RADIALL	ROHDESCHWARZ	ROHDESCHWARZ
Model No.	bnc m st / 142 /bnc m ra 240cm	ENV-216	ESCI
Calibration Date	June 20, 2024	April 07, 2024	January 18, 2024
Calibration Due Date	June 20, 2025	April 07, 2025	January 18, 2025

3) Conductive Measurement Test

Equipment	RF Power Meter with Power Sensor (N1921A)	EMI Test Receiver (9kHz to 26.5GHz)
Registration No.	EW-3309	EW-3156
Manufacturer	ROHDESCHWARZ	ROHDESCHWARZ
Model No.	NRP-Z81	ESR26
Calibration Date	January 23, 2024	January 31, 2024
Calibration Due Date	January 23, 2025	January 31, 2025

4) Control Software for Radiated Emission

Software Information	
Software Name	EMC32
Manufacturer	ROHDESCHWARZ
Software version	10.50.40

END OF TEST REPORT