

TEST REPORT

Report No.: 24120088HKG-001

VTech Telecommunications Ltd.

Application For Original Grant of 47 CFR Part 15 Certification

New Family of RSS-247 Issue 3 Certification

VoIP Phone

FCC ID: EW780-S258-00

IC: 1135B-80S25800

This report contains the data of 2.4GHz Wi-Fi portion only

Prepared and Checked by:

Approved by:

Signed on File

Leung Chun Ning, Peter

Engineer

Wong Cheuk Ho, Herbert

Assistant Manager

Date: March 12, 2025

Intertek's standard Terms and Conditions can be obtained at our website <http://www.intertek.com/terms/>.

The test report only allows to be revised within the retention period unless further standard or the requirement was noticed.

This report is for the exclusive use of Intertek's Client and is provided pursuant to the agreement between Intertek and its Client. Intertek's responsibility and liability are limited to the terms and conditions of the agreement. Intertek assumes no liability to any party, other than to the Client in accordance with the agreement, for any loss, expense or damage occasioned by the use of this report. Only the Client is authorized to permit copying or distribution of this report and then only in its entirety. Any use of the Intertek name or one of its marks for the sale or advertisement of the tested material, product or service must first be approved in writing by Intertek. The observations and test results in this report are relevant only to the sample tested. This report by itself does not imply that the material, product, or service is or has ever been under an Intertek certification program.

© 2017 Intertek

TEST REPORT

GENERAL INFORMATION

Grantee:	VTech Telecommunications Ltd.
Grantee Address:	23/F., Tai Ping Industrial Centre, Block 1, 57 Ting Kok Road, Tai Po, Hong Kong.
Manufacturer Name:	VTech (Dongguan) Telecommunications Limited
Manufacturer Address:	VTech Science Park, Xia Ling Bei Management Zone, Liaobu, Dongguan, Guangdong, China.
FCC Specification Standard:	FCC Part 15, October 1, 2023 Edition
FCC ID:	EW780-S258-00
FCC Model(s):	D815WB, P850BW IP PRO, P855BW IP PRO
IC Specification Standard:	RSS-247 Issue 3, August 2023 RSS-Gen Issue 5 Amendment 2, February 2021
IC:	1135B-80S25800
HVIN:	35-400509BSB
PMN:	D815WB, P850BW IP PRO, P855BW IP PRO
Type of EUT:	Spread Spectrum Transmitter
Description of EUT:	VoIP Phone
Brand Name:	Snom, Gigaset
Sample Receipt Date:	September 27, 2023
Date of Test:	October 12, 2023 to February 26, 2025
Report Date:	March 12, 2025
Environmental Conditions:	Temperature: +10 to 40°C Relative Humidity: 10 to 90%
Conclusion:	Test was conducted by client submitted sample. The submitted sample as received complied with the 47 CFR Part 15 / RSS-247 Issue 3 Certification.

This report contains the data of 2.4GHz Wi-Fi portion only

TEST REPORT

SUMMARY OF TEST RESULT

Test Items	FCC Part 15 Section	RSS-247 / RSS-Gen# Section	Test Engineer	Results
Antenna Requirement	15.203	7.1.2 [#]	N/A	Complied
Max. Conducted Output Power (Peak)	15.247(b)(3)&(4)	5.4(4)	Rain Wang	Complied
Min. 6dB RF Bandwidth	15.247(a)(2)	5.2(1)	Rain Wang	Complied
Max. Power Density (Average)	15.247(e)	5.2(2)	Rain Wang	Complied
Out of Band Antenna Conducted Emission	15.247(d)	5.5	Rain Wang	Complied
Radiated Emission in Restricted Bands and Spurious Emissions	15.247(d), 15.209 & 15.109	5.5	Fire Huo	Complied
AC Power Line Conducted Emission	15.207 & 15.107	7.2.4 [#]	Linson Xie	Complied

Note: Pursuant to FCC Part 15 Section 15.215(c), the 20dB bandwidth of the emission was contained within the frequency band designated (mentioned as above) which the EUT operated. The effects, if any, from frequency sweeping, frequency hopping, other modulation techniques and frequency stability over expected variations in temperature and supply voltage were considered.

For all technical data, which can be referred to Annex B – Report cover sheet.

For electronic filing, the Annex B – Report cover sheet is saved with filename: Annex B.pdf.

The equipment under test is found to be complying with the following standards:

FCC Part 15, October 1, 2023 Edition

RSS-247 Issue 3, August 2023

RSS-Gen Issue 5 Amendment 2, February 2021

TEST REPORT

TABLE OF CONTENTS

EXHIBIT 1 GENERAL DESCRIPTION 5

 1.1 Product Description5

 1.2 Test Methodology5

 1.3 Test Facility.....6

 1.4 Related Submittal(s) Grants6

EXHIBIT 2 SYSTEM TEST CONFIGURATION 7

 2.1 Justification7

 2.2 EUT Exercising Software.....8

 2.3 Details of EUT and Description of Accessories9

 2.4 Measurement Uncertainty.....9

EXHIBIT 3 TEST RESULTS 10

 3.1 Maximum Conducted (Peak) Output Power at Antenna Terminals.....10

 3.2 Minimum 6dB RF Bandwidth12

 3.3 Minimum Power Spectral Density19

 3.4 Out of Band Conducted Emissions.....26

 3.5 Field Strength Calculation42

 3.6 Transmitter Radiated Emissions in Restricted Bands and Spurious Emissions43

 3.7 Transmitter Duty Cycle Calculation56

 3.8 AC Power Line Conducted Emission56

EXHIBIT 4 EQUIPMENT LIST 63

TEST REPORT

EXHIBIT 1 GENERAL DESCRIPTION

1.1 Product Description

The D815WB (35-400509BSB) is a VoIP Phone.

The Equipment Under Test (EUT) operates at frequency range of 2412 MHz to 2462 MHz with 11 channels.

For IEEE 802.11b mode, it operates at frequency range of 2412.000 MHz to 2462.000 MHz with 11 channels. It transmits via Direct-sequence spread spectrum (DSSS) modulation. Maximum bit rate can be up to 11Mbps.

For IEEE 802.11g mode, it operates at frequency range of 2412.000 MHz to 2462.000 MHz with 11 channels. It transmits via Orthogonal Frequency Division Multiplexing (OFDM) modulation. Maximum bit rate can be up to 54Mbps.

For IEEE 802.11n (with 20 MHz bandwidth) mode, it operates at frequency range of 2412.000 MHz to 2462.000 MHz with 11 channels. It transmits via Orthogonal Frequency Division Multiplexing (OFDM) modulation. Maximum bit rate can support up to 65Mbps.

The EUT is powered by 100-240VAC 50/60Hz 0.3A or 100-240VAC 50/60Hz 0.5A adaptor.

The difference in model number represent the following as declared by client:

Models	Description
D815WB	Has 1 USB port, directory, conference, Built-in Wi-Fi (2.4GHz + 5GHz), built-in BT and without DECT
P850BW IP PRO	Identical to Model D815WB except for Model number and brand name
P855BW IP PRO	Identical to Model D815WB except for Model number and brand name, and with mechanical hinge on LCD

The representative model(s) D815WB was selected to test.

The antenna(s) used in the EUT is integral, and the test sample is a prototype.
Peak Antenna Gain: 1dBi

The circuit description is saved with filename: descri.pdf.

1.2 Test Methodology

Both AC power line-conducted and radiated emission measurements were performed according to the procedures in ANSI C63.10 (2013). Preliminary radiated scans and all radiated measurements were performed in radiated emission test sites. All Radiated tests were performed at an antenna to EUT distance of 3 meters, unless stated otherwise in the "Justification Section" of this Application. Antenna port conducted measurements were performed according to ANSI C63.10 (2013) and KDB Publication No. 558074 D01 v05r02 (April 02, 2019) All other measurements were made in accordance with the procedures in 47 CFR Part 2 and RSS-Gen Issue 5 Amendment 2, February 2021.

TEST REPORT

1.3 Test Facility

The radiated emission (15.209) test site are at Workshop No. 3, G/F., World-Wide Industrial Centre, 43-47 Shan Mei Street, Fo Tan, Sha Tin, N.T., Hong Kong SAR, China. This test facility and site measurement data have been fully placed on file with the FCC and Industry Canada No.: 2042H, CABID is "HKAP01".

The radiated emission (except 15.209) test site and antenna port conducted measurement facility used to collect the radiated data and conductive data are at Shenzhen UnionTrust Quality and Technology Co., Ltd. at 16/F., Block A, Building 6, Baoneng Science and Technology Park, Qingxiang Road No.1, Longhua New District, Shenzhen, China 518109. This test facility and site measurement data have been fully placed on file with the FCC and Industry Canada No.: 21600, CABID "HKAP01", "CN0023".

1.4 Related Submittal(s) Grants

This is a single application for certification of a transceiver (WiFi Portion).

TEST REPORT

EXHIBIT 2 SYSTEM TEST CONFIGURATION

2.1 Justification

For radiated emissions testing, the equipment under test (EUT) was setup to transmit / receive continuously to simplify the measurement methodology. Care was taken to ensure proper power supply voltages during testing. During testing, all cables (if any) were manipulated to produce worst case emissions.

The EUT was powered by 120VAC during test.

For the measurements, the EUT was attached to a plastic stand if necessary and placed on the wooden turntable at 0.8m height from the ground plane for emission testing at or below 1GHz and 1.5m for emission measurements above 1GHz. If the EUT attached to peripherals, they were connected and operational (as typical as possible).

The signal was maximized through rotation and placement in the three orthogonal axes. The antenna height and polarization were varied during the search for maximum signal level. The antenna height was varied from 1 to 4 meters. Radiated emissions were taken at three meters unless the signal level was too low for measurement at that distance. If necessary, a pre-amplifier was used and/or the test was conducted at a closer distance.

For any intentional radiator powered by AC power line, measurements of the radiated signal level of the fundamental frequency component of the emission was performed with the supply voltage varied between 85% and 115% of the nominal rated supply voltage.

Radiated emission measurement for transmitter were performed from the lowest radio frequency signal generated in the device which is greater than 9 kHz to the tenth harmonic of the highest fundamental frequency or to 40 GHz, whichever is lower.

Emission that are directly caused by digital circuits in the transmit path and transmitter portion were measured, and the limit are according to FCC Part 15 Section 15.209 / RSS-247 2.5. Digital circuitries used to control additional functions other than the operation of the transmitter are subject to FCC Part 15 Section 15.109 / RSS-247 Section 5.5 Limits.

TEST REPORT

2.1 Justification (Cont'd)

Detector function for radiated emissions was in peak mode. Average readings, when required, were taken by measuring the duty cycle of the equipment under test and subtracting the corresponding amount in dB from the measured peak readings. A detailed description for the calculation of the average factor can be found in section 4.8.3.

Determination of pulse desensitization was made according to *Hewlett Packard Application Note 150-2, Spectrum Analysis... Pulsed RF*. The effective period (Teff) was referred to Exhibit 4.8.3. With the resolution bandwidth 1MHz and spectrum analyzer IF bandwidth 3dB, the pulse desensitization factor was 0dB.

For AC power line-conducted emission test, the EUT along with its peripherals were placed on a 1.0m(W)x1.5m(L) and 0.8m in height wooden table and the EUT was adjusted to maintain a 0.4 meter space from a vertical reference plane. The EUT was connected to power mains through a line impedance stabilization network (LISN), which provided 50ohm coupling impedance for measuring instrument. The LISN housing, measuring instrument case, reference ground plane, and vertical ground plane were bounded together. The excess power cable between the EUT and the LISN was bundled.

All connecting cables of EUT and peripherals were manipulated to find the maximum emission.

Different data rates have been tested. Worst case is reported only.

Different adaptors have been used for testing. Worst case is reported only.

All relevant operation modes have been tested, and the worst-case data is included in this report.

All data rates were tested under normal mode of WiFi. Only the worst-case data is shown in the report for DSSS and OFDM.

For simultaneous transmission, both Wi-Fi and Bluetooth portions are also switched on when taking radiated emission for determining worst-case spurious emission.

2.2 EUT Exercising Software

The EUT exercise program (Tera Terms Version 4.106) used during radiated and conducted testing was designed to exercise the various system components in a manner similar to a typical use.

TEST REPORT

2.3 Details of EUT and Description of Accessories

Details of EUT:

An AC/DC Adaptor (provided with the unit) was used to power the device.
Their descriptions are listed below.

- (1) An AC adaptor (Model: NBS12E050200UV; Brand Name: MASS POWER; Input: 100-240VAC 50/60Hz 0.3A; Output: 5.0VDC 2.0A 10.0W) (Provided by Applicant)
- (2) An AC adaptor (Model: VT07EUS05200; Brand Name: VTPL; Input: 100-240VAC 50/60Hz 0.5A; Output: 5.0VDC 2.0A 10.0W) (Provided by Applicant)

Description of Accessories:

Not Applicable

2.4 Measurement Uncertainty

Decision Rule for compliance: For FCC/IC standard, the measured value must be within the limits of applicable standard without accounting for the measurement uncertainty. For EN/IEC/HKTA/HKTC standard, conformity rules will be used as per standard directly excepted EN/IEC 61000-3-2, EN/IEC 61000-3-3, HKTA1004, HKCA1008, HKTA1019, HKTA1020, HKTA1041 and HKTA1044.

Uncertainty and Compliance - Unless the standard specifically states that measured values are to be extended by the measurement uncertainty in determining compliance, all compliance determinations are based on the actual measured value.

TEST REPORT

EXHIBIT 3 TEST RESULTS

3.1 Maximum Conducted (Peak) Output Power at Antenna Terminals

RF Conduct Measurement Test Setup

The figure below shows the test setup, which is utilized to make these measurements.

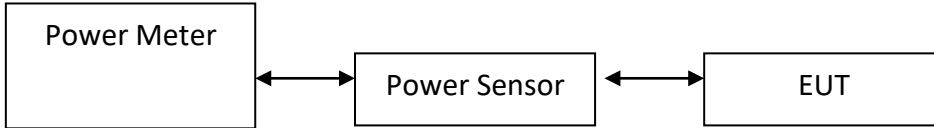

The antenna port of the EUT was connected to the input of a spectrum analyzer.

- The antenna power of the EUT was connected to the input of a power meter. Power was read directly and cable loss correction was added to the reading to obtain power at the EUT antenna terminals. The measurement procedure 8.3.2.3 was used.
- The EUT should be configured to transmit continuously (at a minimum duty cycle of 98%) at full power over the measurement duration. The measurement procedure AVG1 was used.

IEEE 802.11b (DSSS, 1 Mbps) Peak Antenna Gain = 1 dBi

Frequency (MHz)	Output in dBm	Output in mW
Low Channel: 2412	19.27	84.53
Middle Channel: 2437	19.06	80.54
High Channel: 2462	18.67	73.62

IEEE 802.11g (OFDM, 6 Mbps) Peak Antenna Gain = 1 dBi

Frequency (MHz)	Output in dBm	Output in mW
Low Channel: 2412	23.80	239.88
Middle Channel: 2437	23.41	219.28
High Channel: 2462	23.18	207.97

IEEE 802.11n (20MHz) (OFDM, MCS0) Peak Antenna Gain = 1 dBi

Frequency (MHz)	Output in dBm	Output in mW
Low Channel: 2412	23.37	217.27
Middle Channel: 2437	22.96	197.70
High Channel: 2462	22.63	183.23

TEST REPORT

3.1 Maximum Conducted (Peak) Output Power at Antenna Terminals (Cont'd)

Cable loss: 0.5 dB External Attenuation: 0 dB

Cable loss, external attenuation: included in OFFSET function
 added to SA raw reading

IEEE 802.11b (DSSS, 1 Mbps)

Max. Conducted (Peak) Output Level = 19.27 dBm

IEEE 802.11g (OFDM, 6 Mbps)

Max. Conducted (Peak) Output Level = 23.80 dBm

IEEE 802.11n (20MHz) (OFDM, MCS0)

Max. Conducted (Peak) Output Level = 23.37 dBm

Limits:

1W (30dBm) for antennas with gains of 6dBi or less.

TEST REPORT

3.2 Minimum 6dB RF Bandwidth

The figure below shows the test setup, which is utilized to make these measurements.

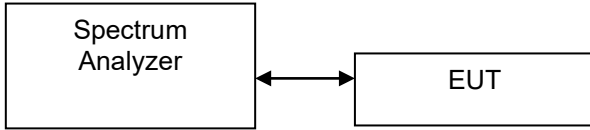

The antenna port of the EUT was connected to the input of a spectrum analyzer. The EBW measurement procedure was used. A PEAK output reading was taken, a DISPLAY line was drawn 6dB lower than PEAK level. The 6dB bandwidth was determined from where the channel output spectrum intersected the display line.

IEEE 802.11b (DSSS, 1 Mbps)

Frequency (MHz)	6dB Bandwidth (MHz)
Low Channel: 2412	10.11
Middle Channel: 2437	10.10
High Channel: 2462	10.11

IEEE 802.11g (OFDM, 6 Mbps)

Frequency (MHz)	6dB Bandwidth (MHz)
Low Channel: 2412	16.54
Middle Channel: 2437	16.54
High Channel: 2462	16.52

IEEE 802.11n (20MHz) (OFDM, MCS0)

Frequency (MHz)	6dB Bandwidth (MHz)
Low Channel: 2412	17.65
Middle Channel: 2437	17.71
High Channel: 2462	17.68

Limits:

6dB bandwidth shall be at least 500kHz.

The plots of 6dB RF bandwidth are saved as below.

TEST REPORT

PLOTS OF 6dB RF BANDWIDTH

802.11b, Lowest Channel

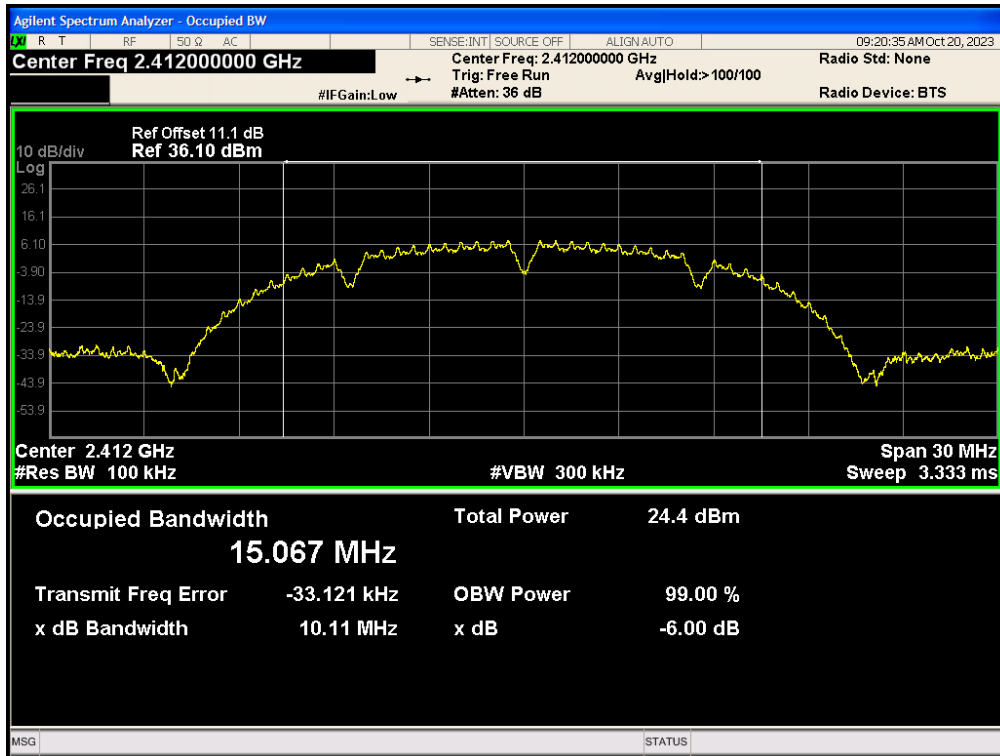

802.11b, Middle Channel

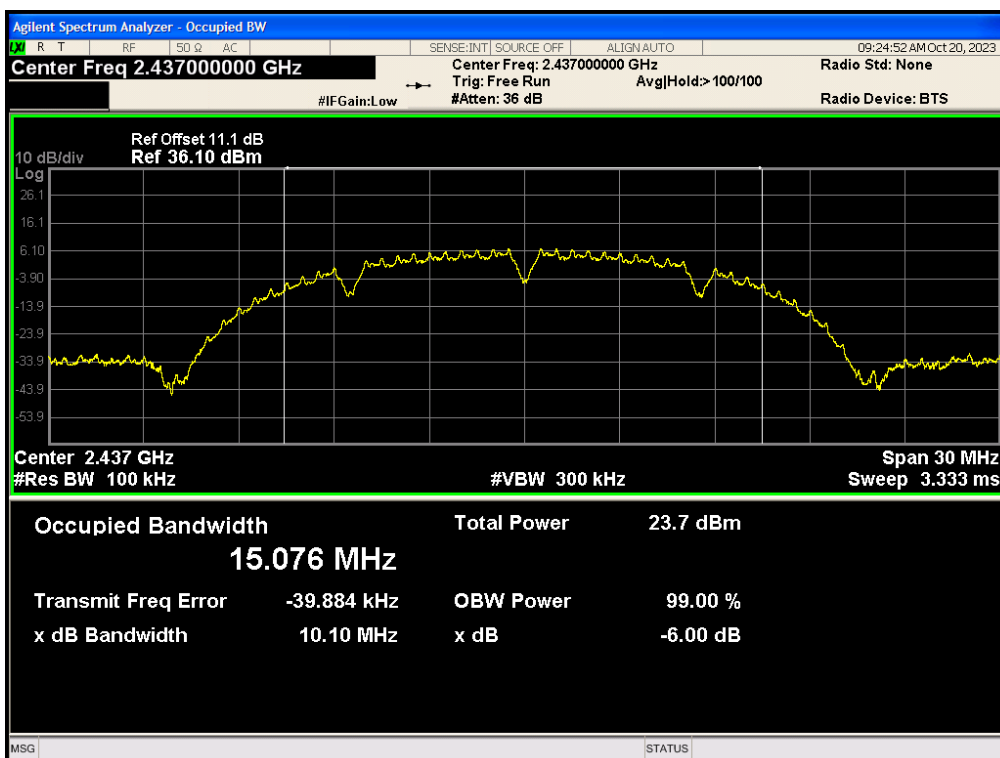

TEST REPORT

PLOTS OF 6dB RF BANDWIDTH

802.11b, Highest Channel

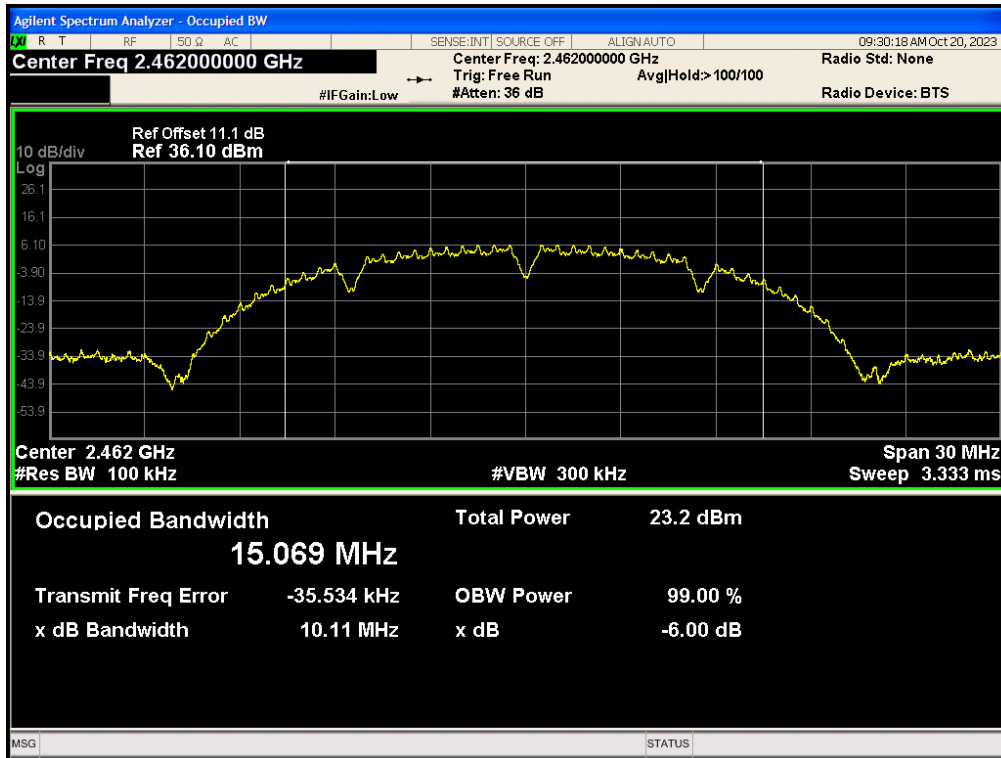

TEST REPORT

PLOTS OF 6dB RF BANDWIDTH

802.11g, Lowest Channel

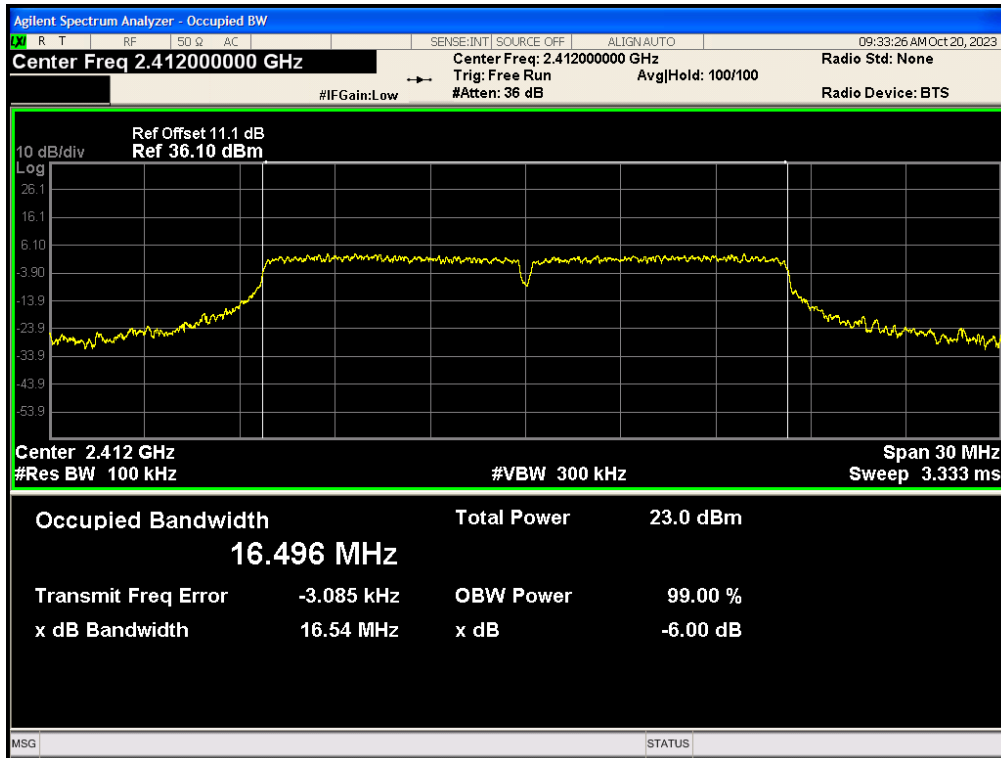

802.11g, Middle Channel

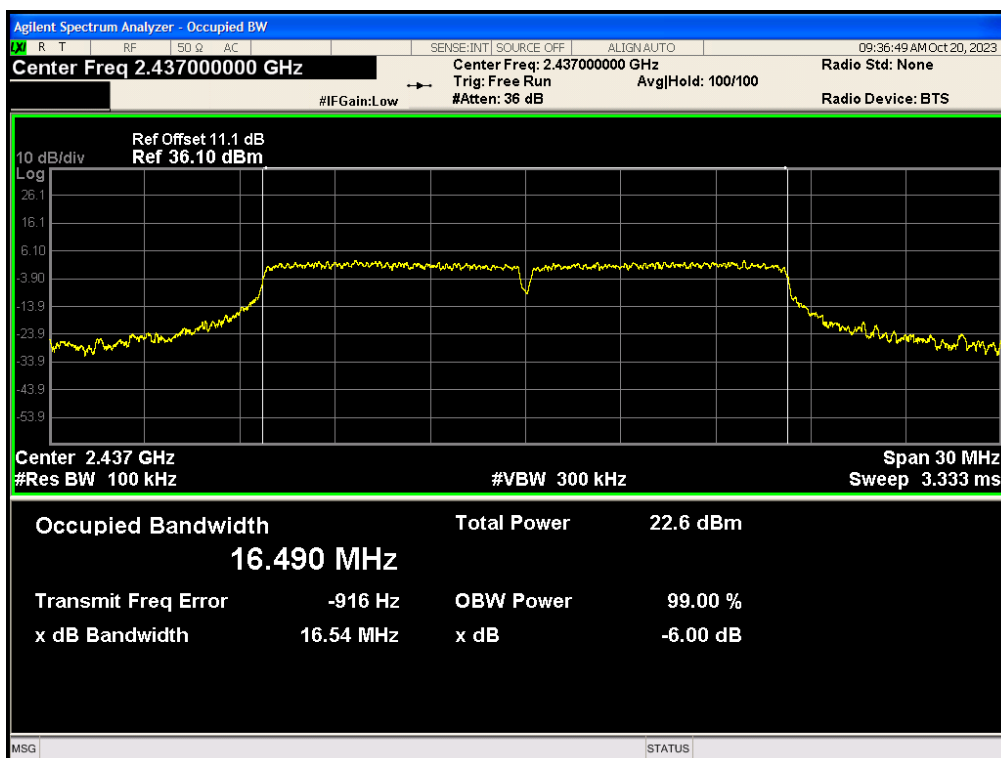

TEST REPORT

PLOTS OF 6dB RF BANDWIDTH

802.11g, Highest Channel

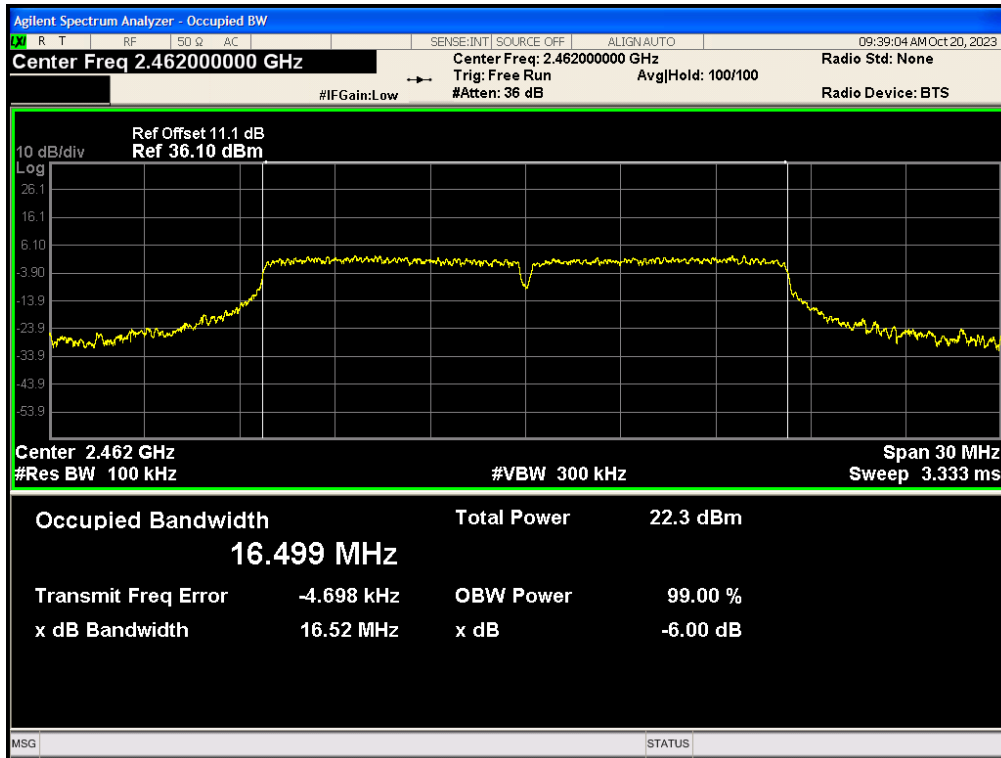

TEST REPORT

PLOTS OF 6dB RF BANDWIDTH

802.11n (20MHz), Lowest Channel

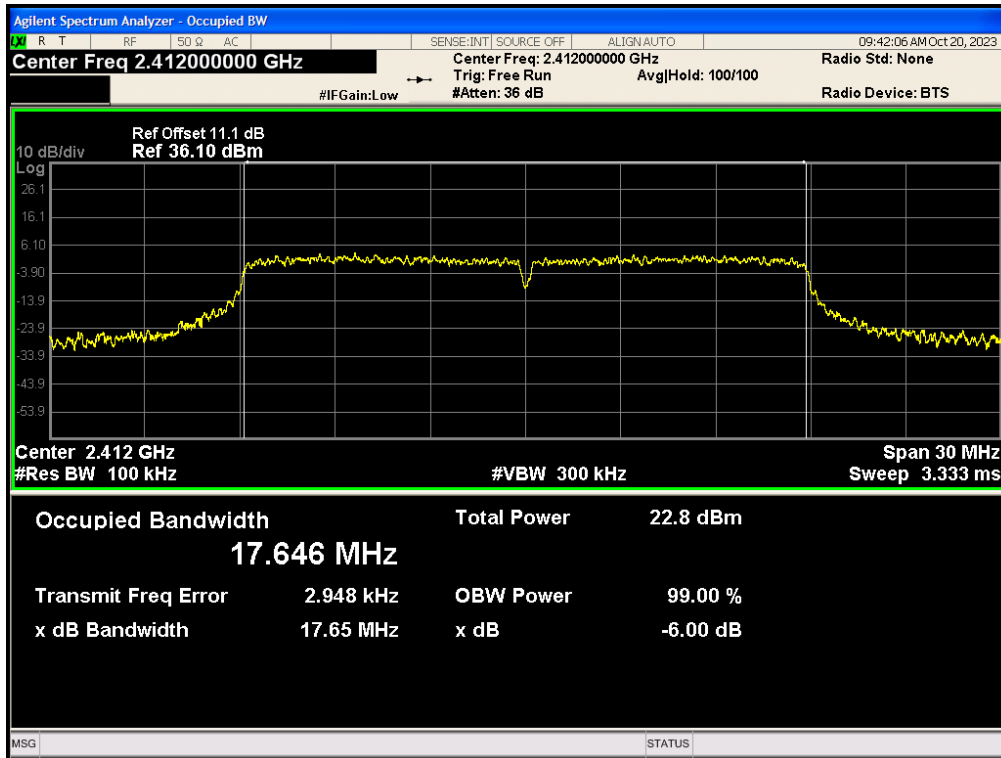

802.11n (20MHz), Middle Channel

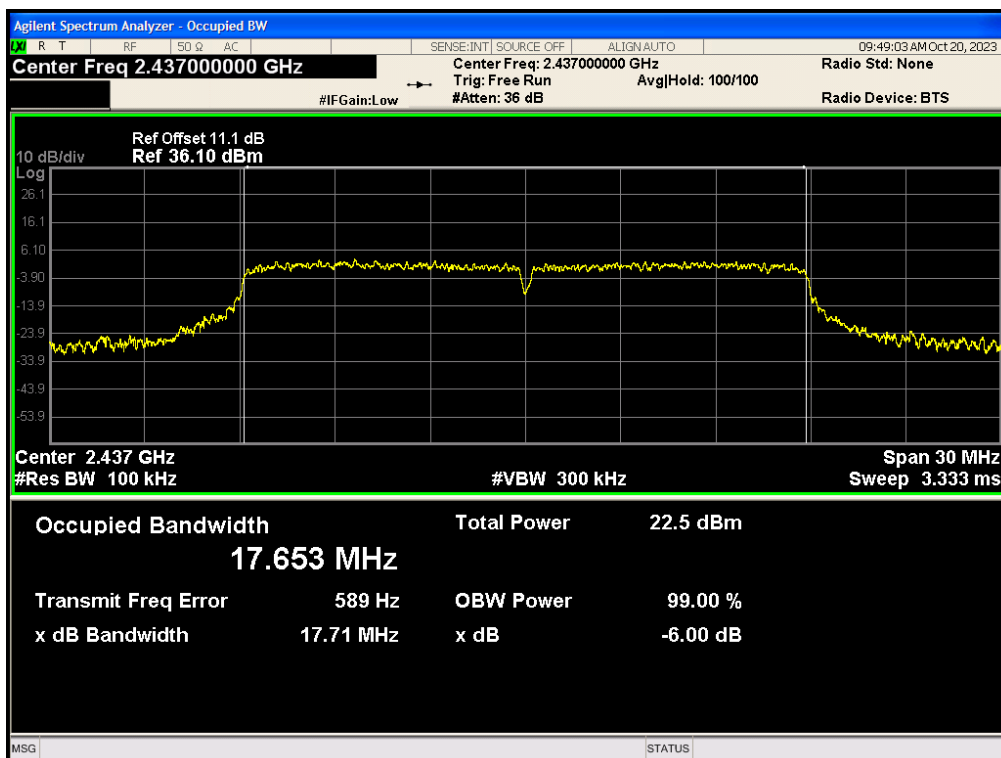

TEST REPORT

PLOTS OF 6dB RF BANDWIDTH

802.11n (20MHz), Highest Channel

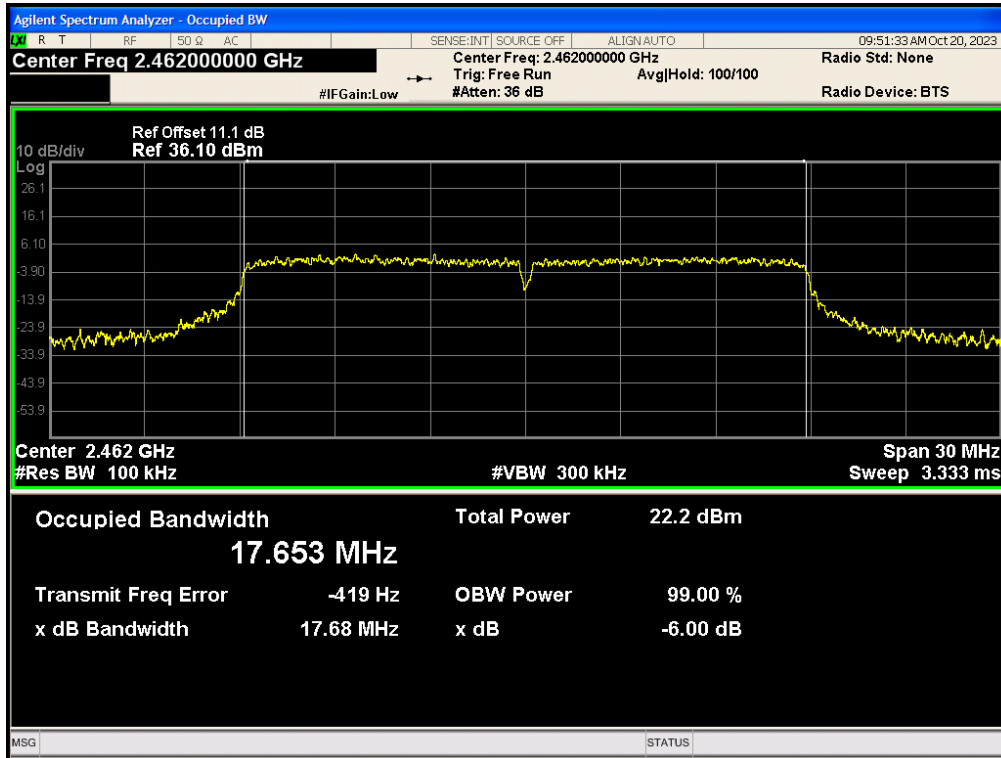

TEST REPORT

3.3 Minimum Power Spectral Density

The figure below shows the test setup, which is utilized to make these measurements.

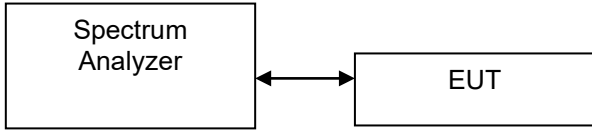

Antenna output of the EUT was coupled directly to spectrum analyzer. The measurement procedure 10.2 PKPSD was used. If an external attenuator and/or cable was used, these losses are compensated for using the OFFSET function of the analyser.

IEEE 802.11b (DSSS, 1 Mbps)

Frequency (MHz)	PSD in 3kHz (dBm)
Low Channel: 2412	-12.770
Middle Channel: 2437	-13.302
High Channel: 2462	-13.770

IEEE 802.11g (OFDM, 6 Mbps)

Frequency (MHz)	PSD in 3kHz (dBm)
Low Channel: 2412	-11.219
Middle Channel: 2437	-11.470
High Channel: 2462	-11.823

IEEE 802.11n (20MHz) (OFDM, MCS0)

Frequency (MHz)	PSD in 3kHz (dBm)
Low Channel: 2412	-10.052
Middle Channel: 2437	-10.446
High Channel: 2462	-10.715

Cable Loss: 0.5dB

Limit: 8dBm in 3kHz

The plots of power spectral density are as below.

TEST REPORT

PLOTS OF POWER SPECTRAL DENSITY

802.11b, Lowest channel

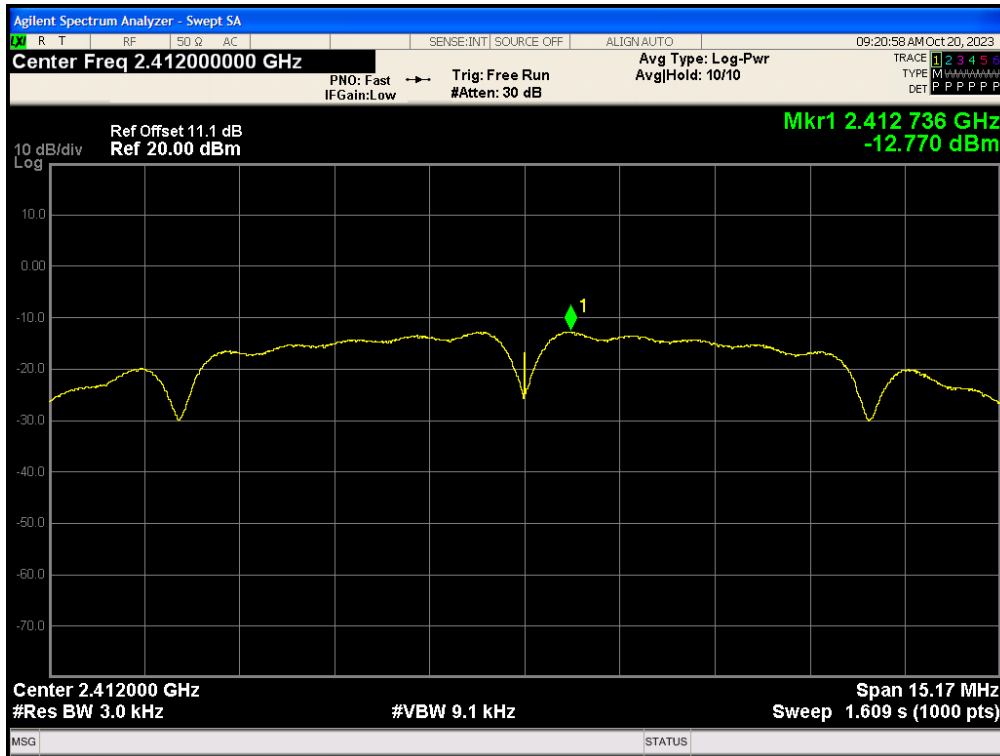

802.11b, Middle channel

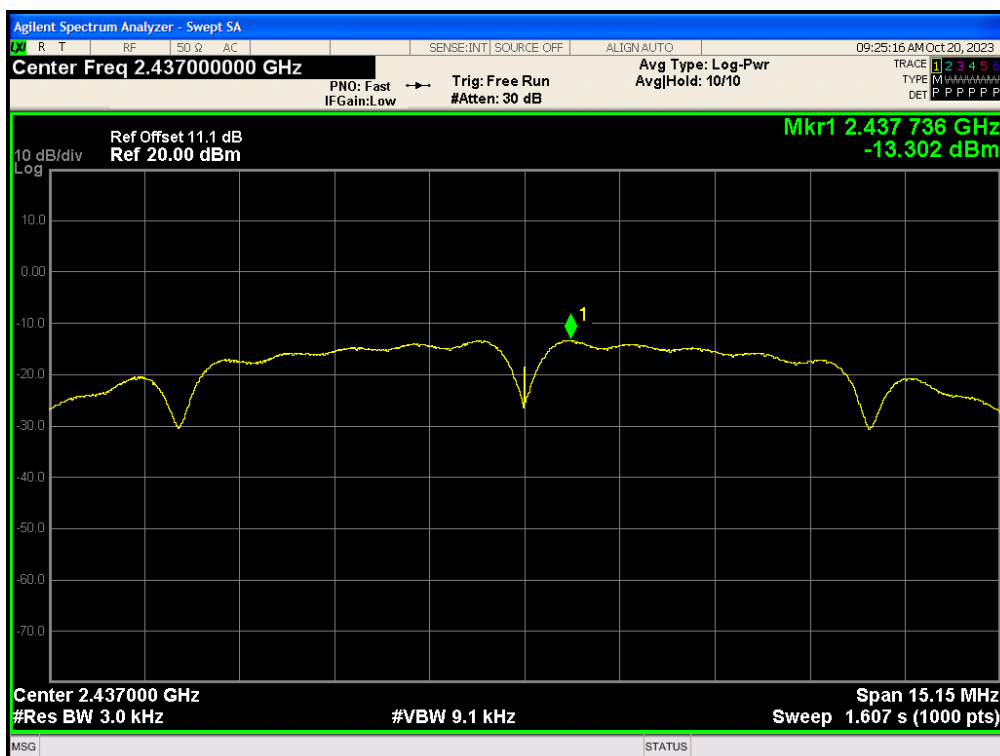

TEST REPORT

PLOTS OF POWER SPECTRAL DENSITY

802.11b, Highest channel

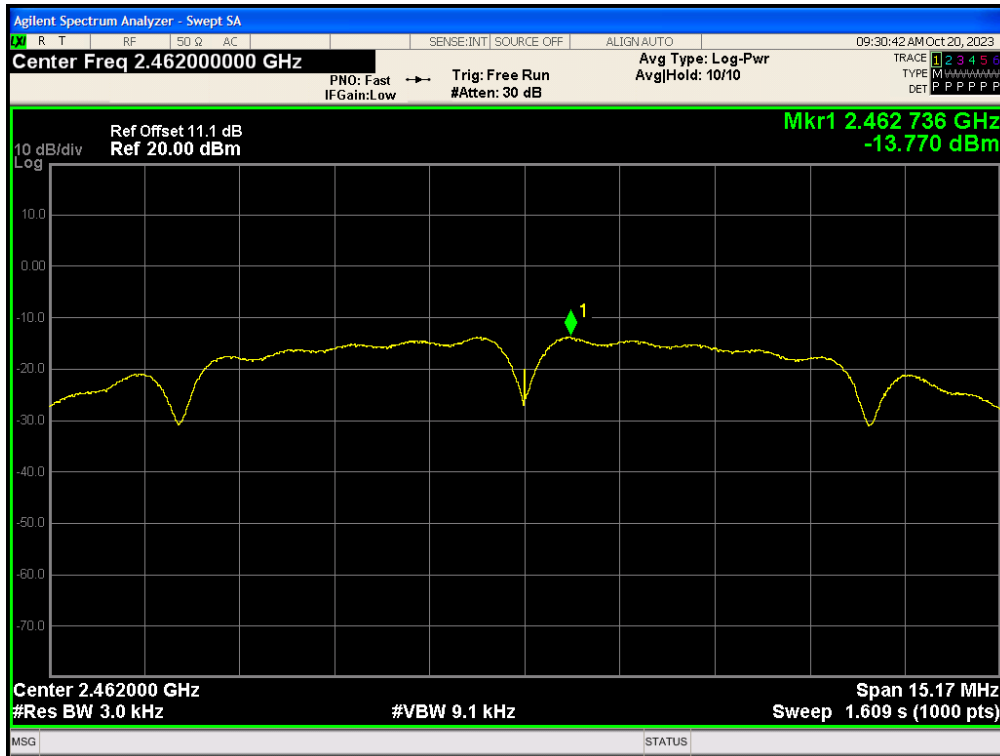

TEST REPORT

PLOTS OF POWER SPECTRAL DENSITY

802.11g, Lowest channel

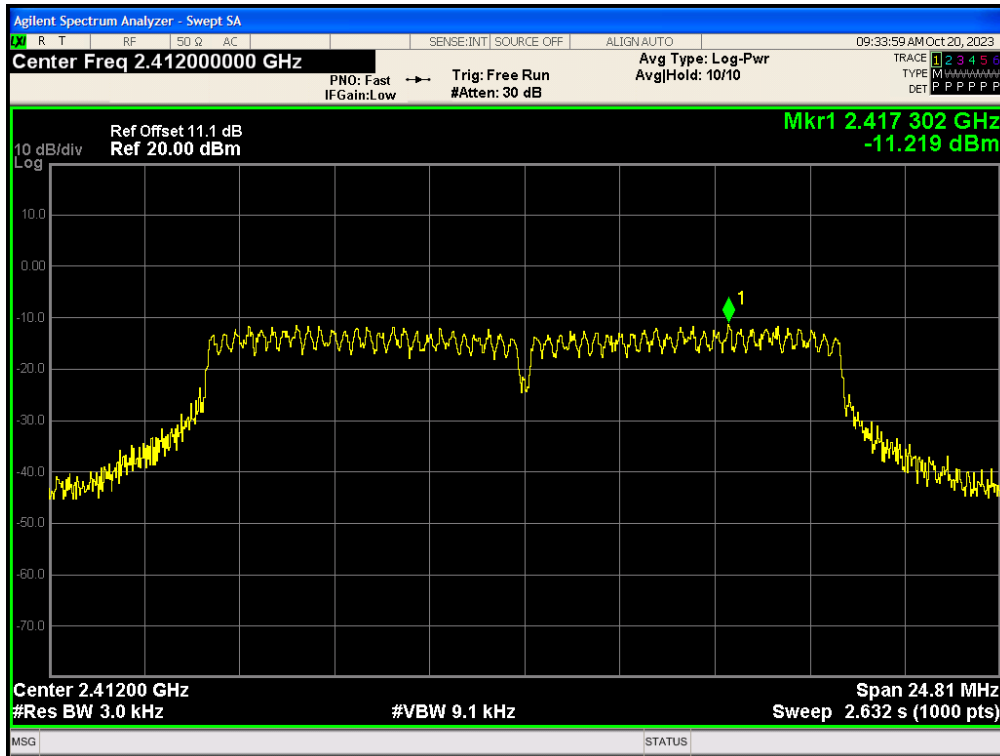

802.11g, Middle channel

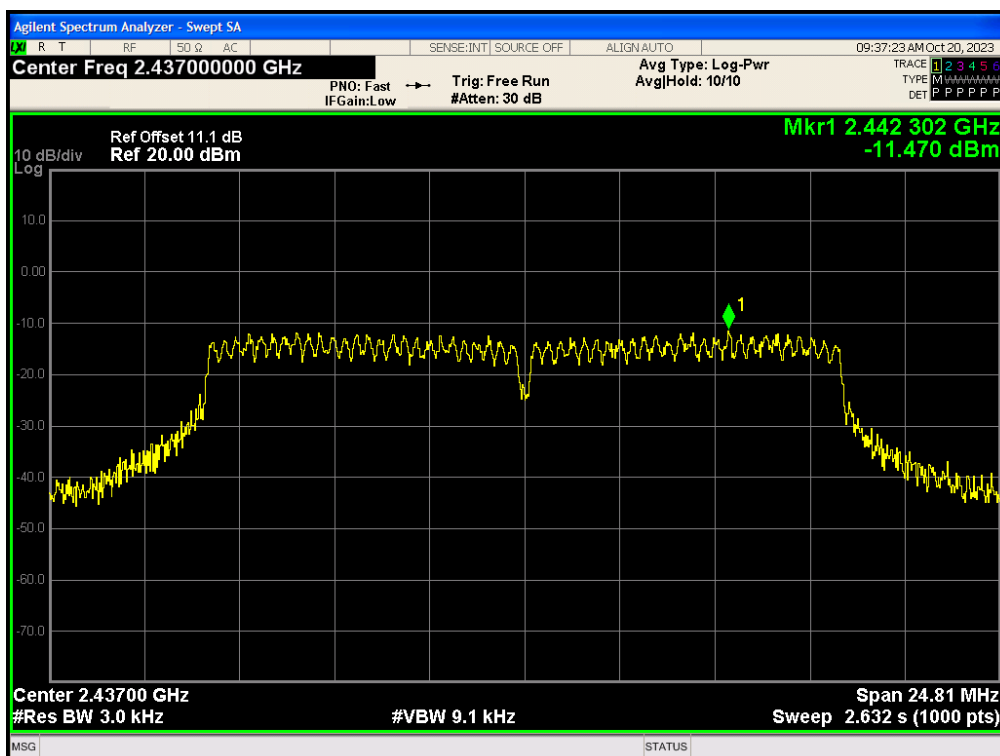

TEST REPORT

PLOTS OF POWER SPECTRAL DENSITY

802.11g, Highest channel

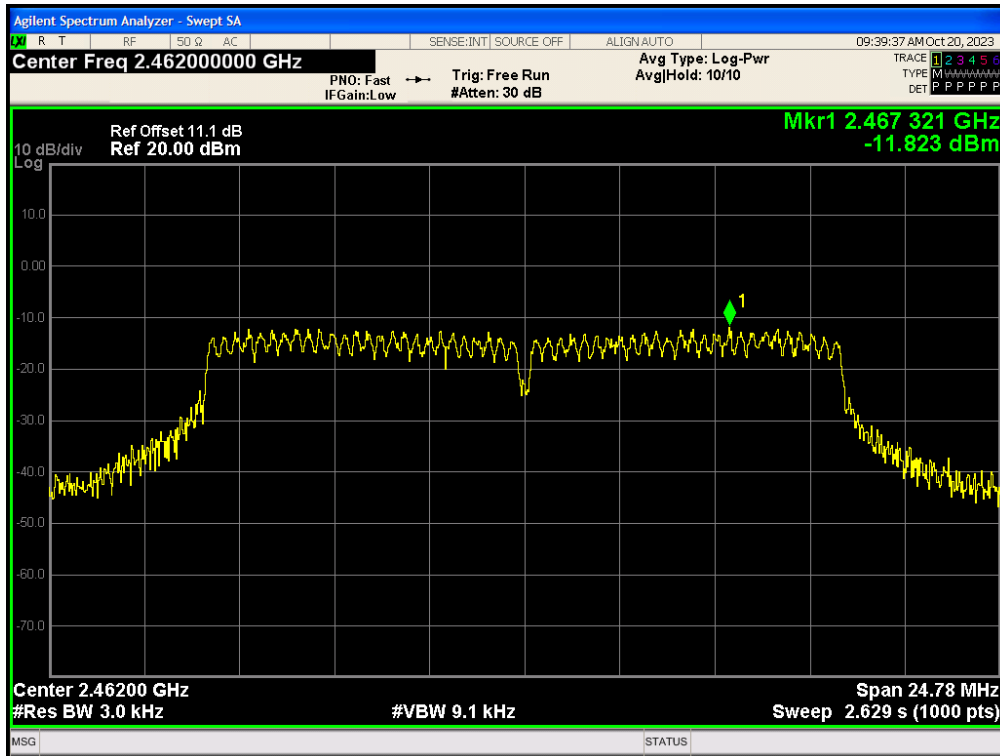

TEST REPORT

PLOTS OF POWER SPECTRAL DENSITY

802.11n (20MHz), Lowest channel

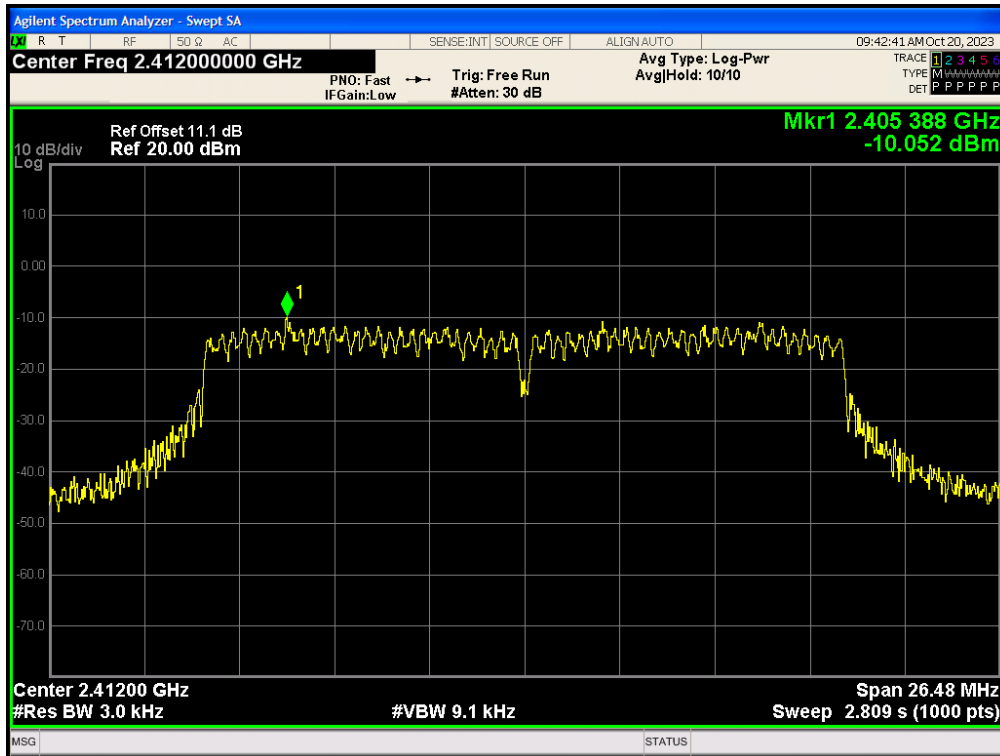

802.11n (20MHz), Middle channel

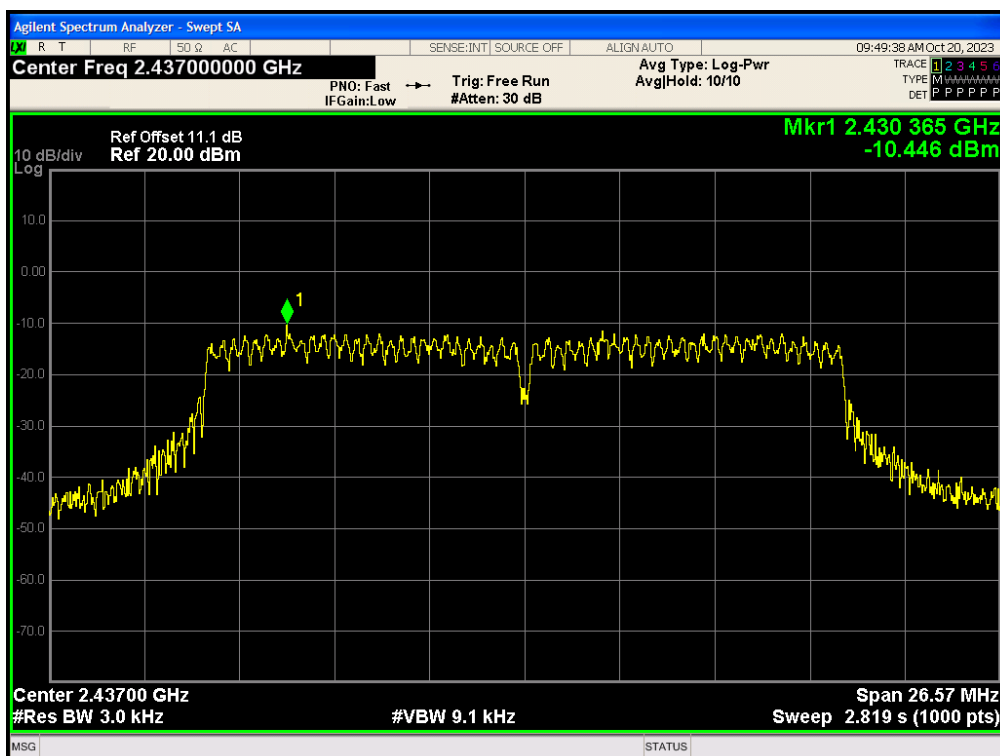

TEST REPORT

PLOTS OF POWER SPECTRAL DENSITY

802.11n (20MHz), Highest channel

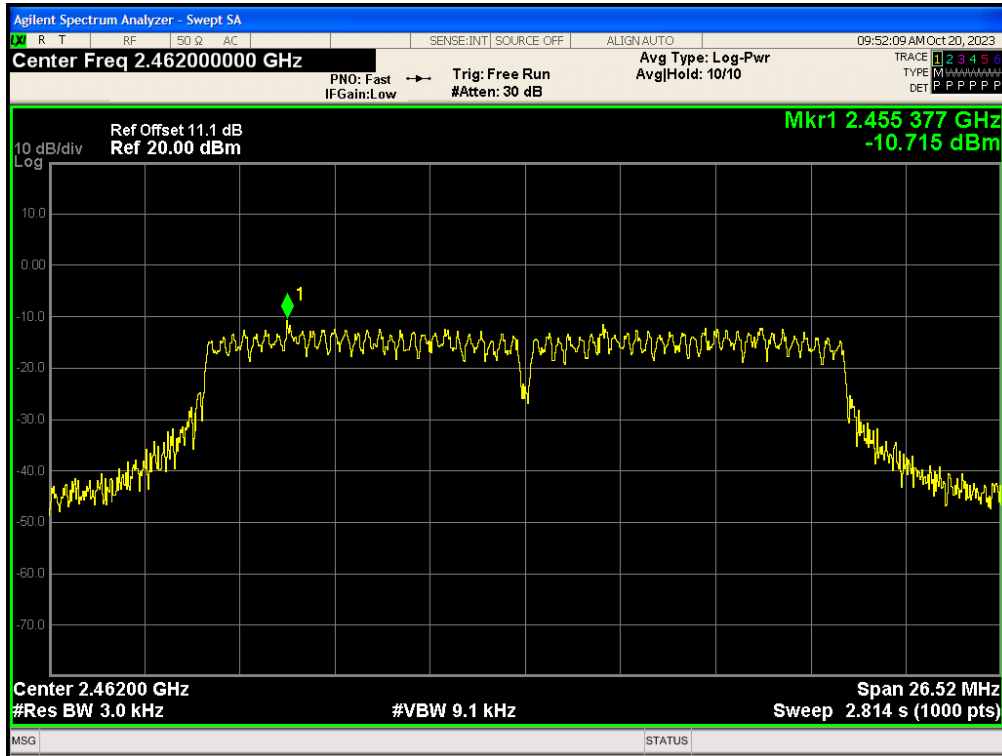

TEST REPORT

3.4 Out of Band Conducted Emissions

The figure below shows the test setup, which is utilized to make these measurements.

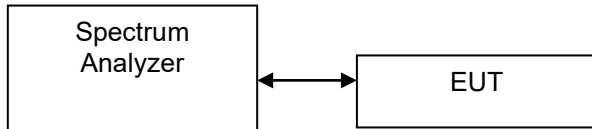

For IEEE 802.11b/g/n20MHz, the maximum conducted (peak) output power was used to demonstrate compliance as described in 9.1. Then the display line (in red) shown in the following plots denotes the limit at 20dB below maximum measured in-band peak PSD level in 100 KHz bandwidth for IEEE 802.11b/g/n20MHz.

The measurement procedures under sections 11 of KDB558074 D01 v05r02 (April 2, 2019) were used.

Furthermore, delta measurement technique for measuring bandedge emissions was incorporated in the test of the edge at 2483.5MHz.

Limits:

All spurious emission and up to the tenth harmonic was measured and they were found to be at least 20dB below the maximum measured in-band peak PSD level for IEEE 802.11b/g/n20MHz.

The plots of out of band conducted emissions are as below.

TEST REPORT

PLOTS OF OUT OF BAND CONDUCTED EMISSIONS

802.11b, Lowest Channel, PSD in 100k

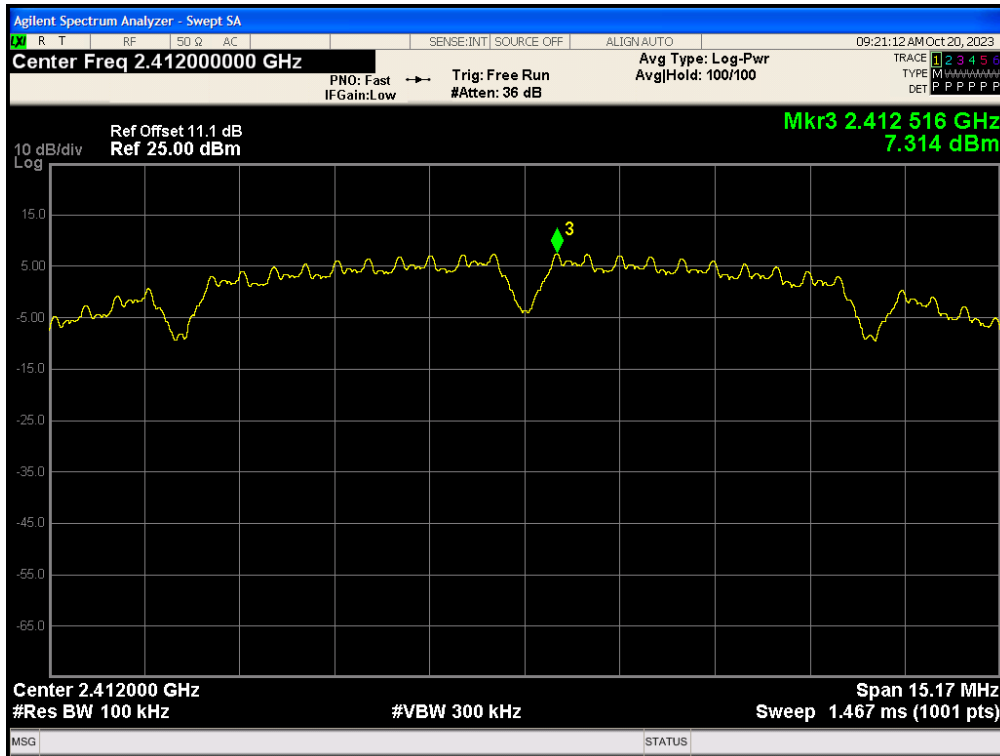

802.11b, Lowest Channel, Bandedge

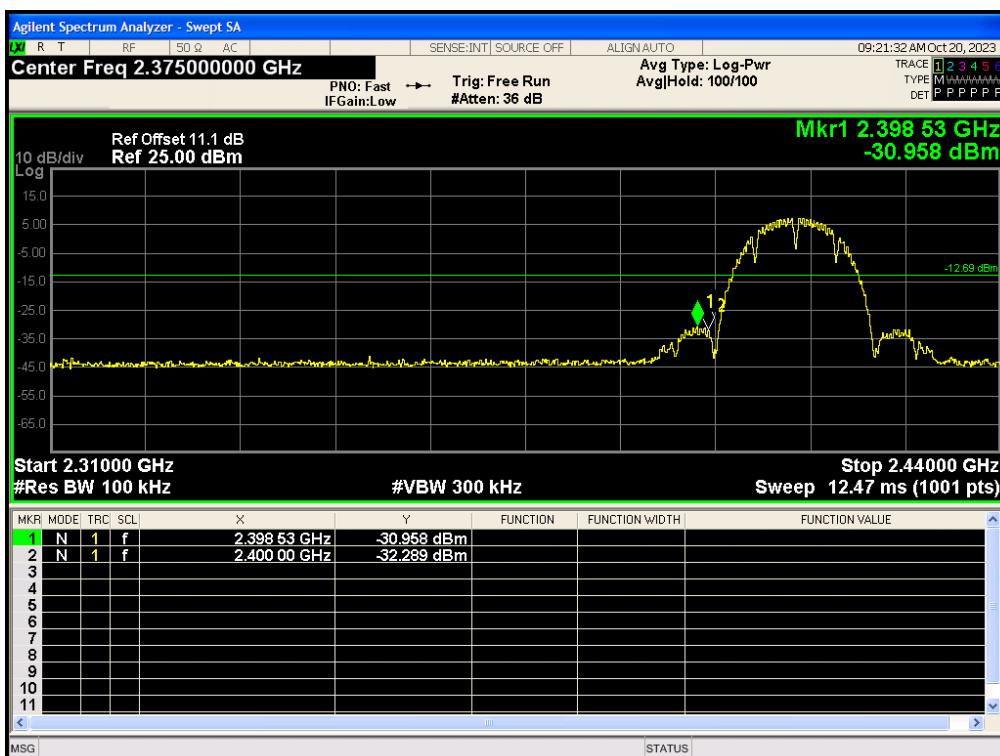

TEST REPORT

PLOTS OF OUT OF BAND CONDUCTED EMISSIONS

802.11b, Lowest Channel, Plot

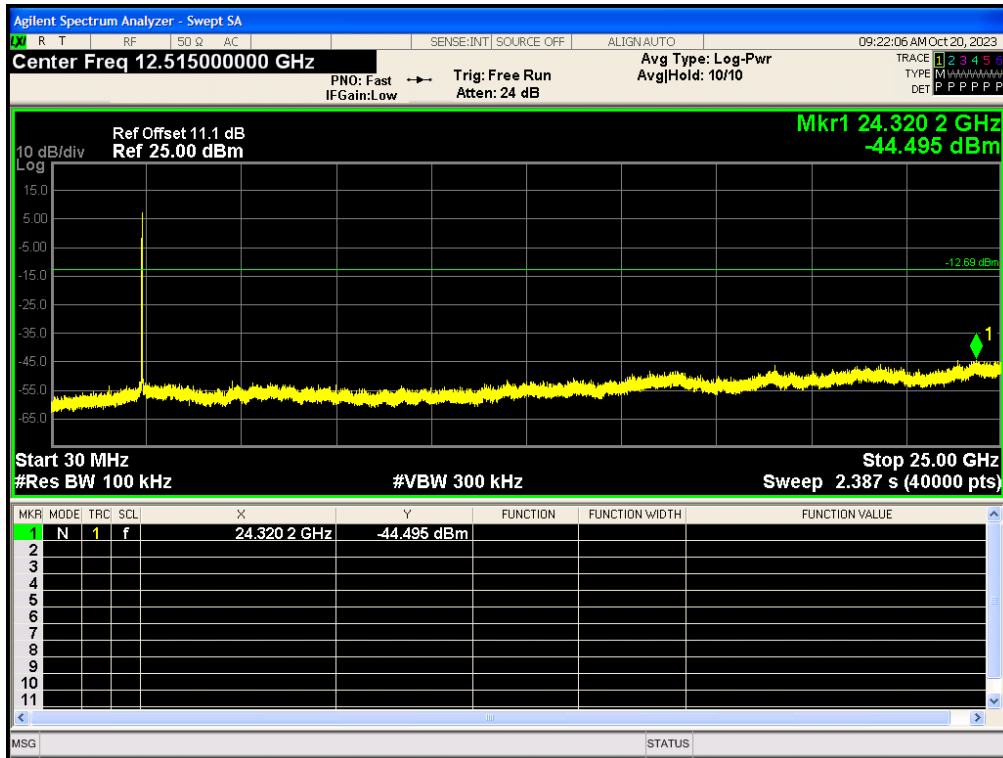

TEST REPORT

PLOTS OF OUT OF BAND CONDUCTED EMISSIONS

802.11b, Middle Channel, PSD in 100k

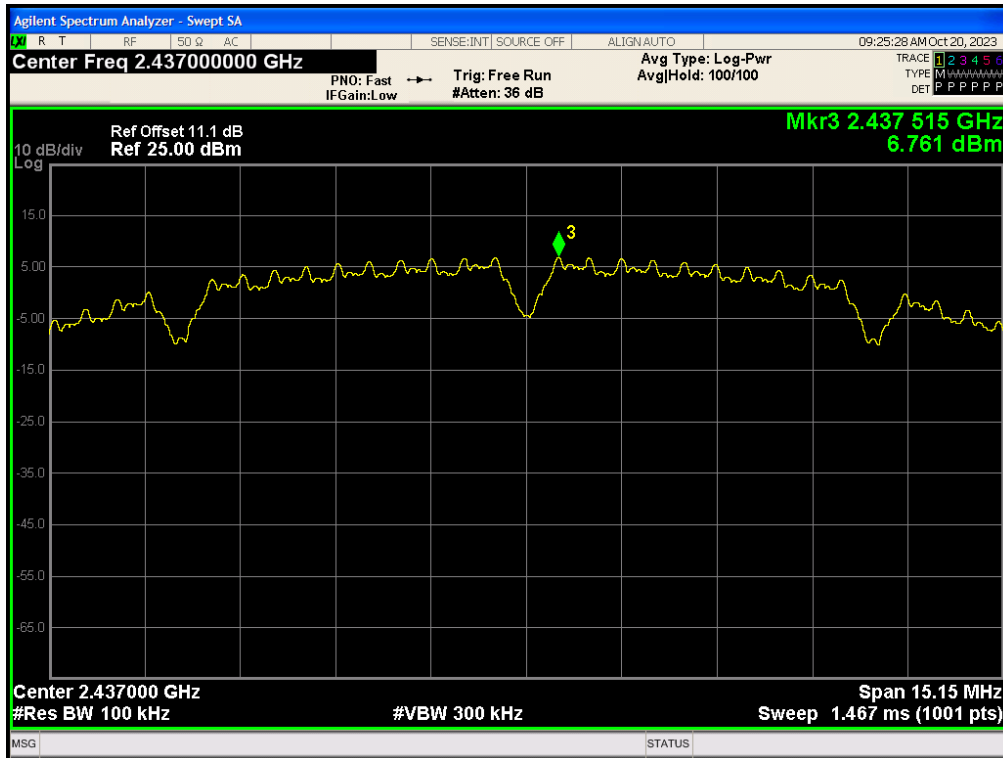

802.11b, Middle Channel, Plot

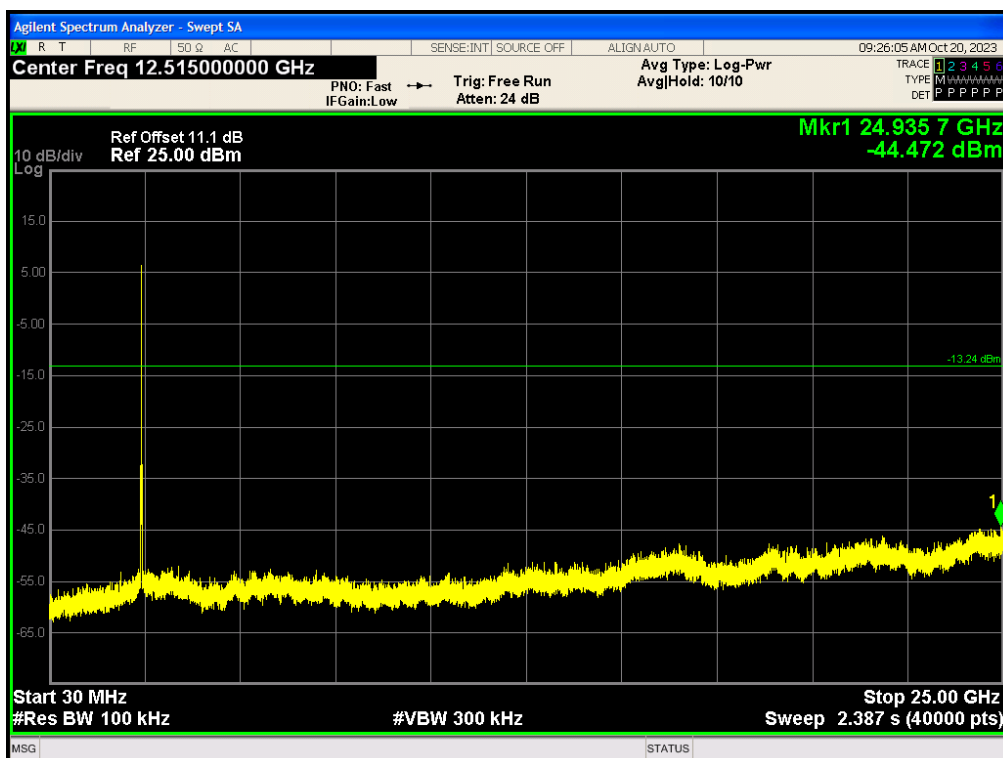

TEST REPORT

PLOTS OF OUT OF BAND CONDUCTED EMISSIONS

802.11b, Highest Channel, PSD in 100k

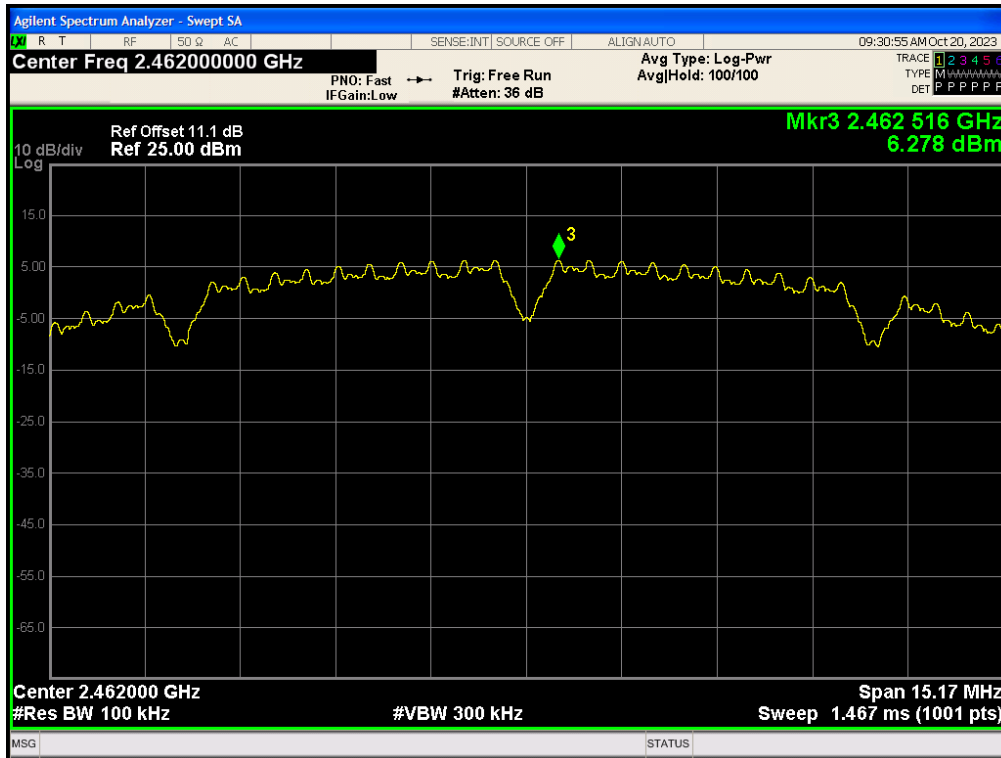

802.11b, Highest Channel, Bandedge

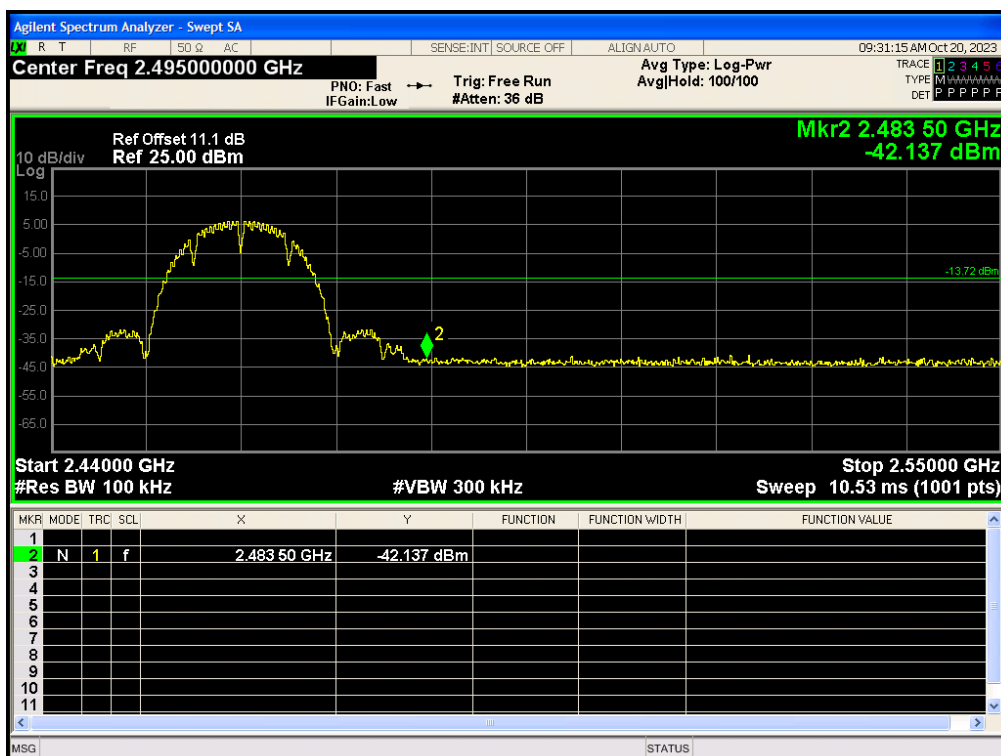

TEST REPORT

PLOTS OF OUT OF BAND CONDUCTED EMISSIONS

802.11b, Highest Channel, Plot

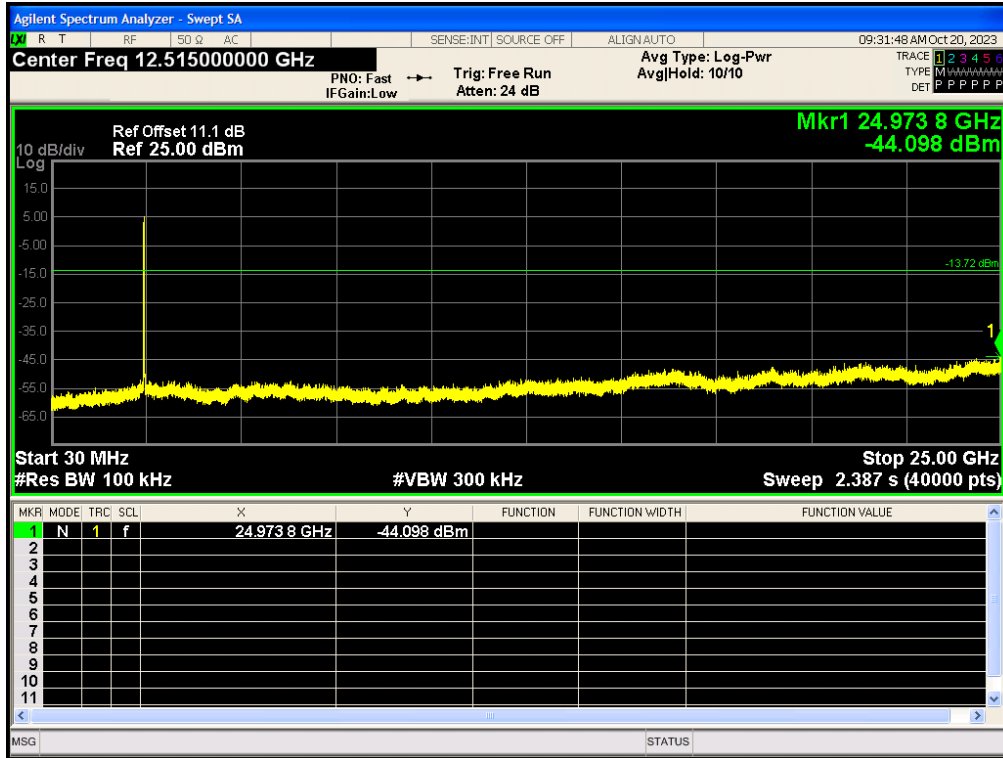

TEST REPORT

PLOTS OF OUT OF BAND CONDUCTED EMISSIONS

802.11g, Lowest Channel, PSD in 100k

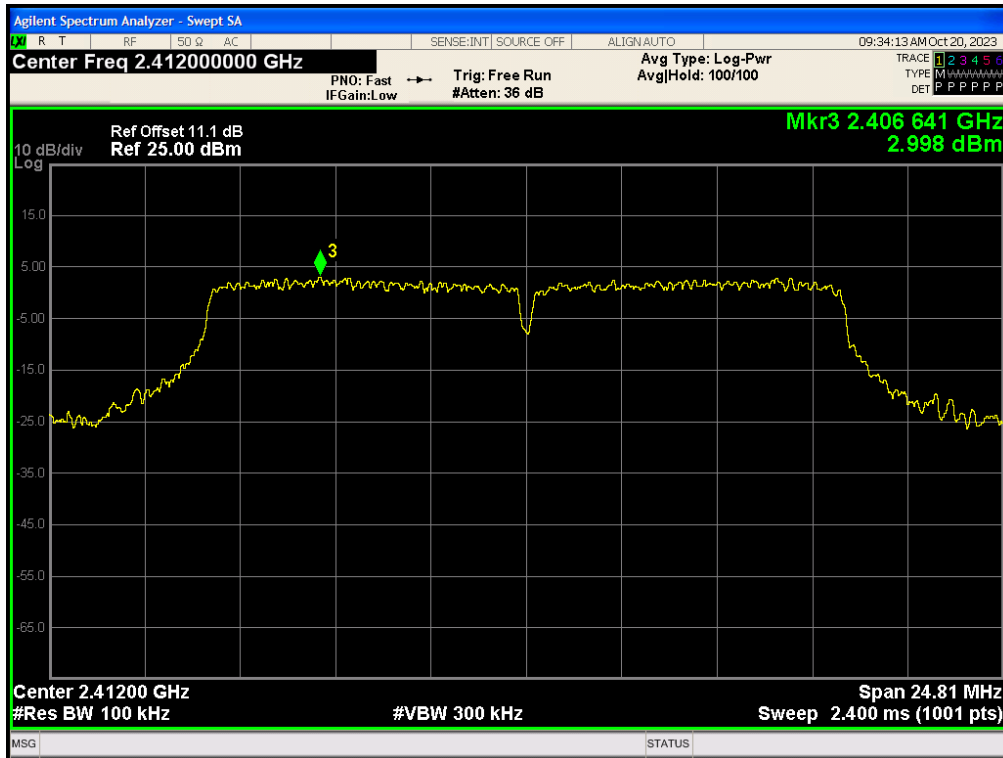

802.11g, Lowest Channel, Bandedge

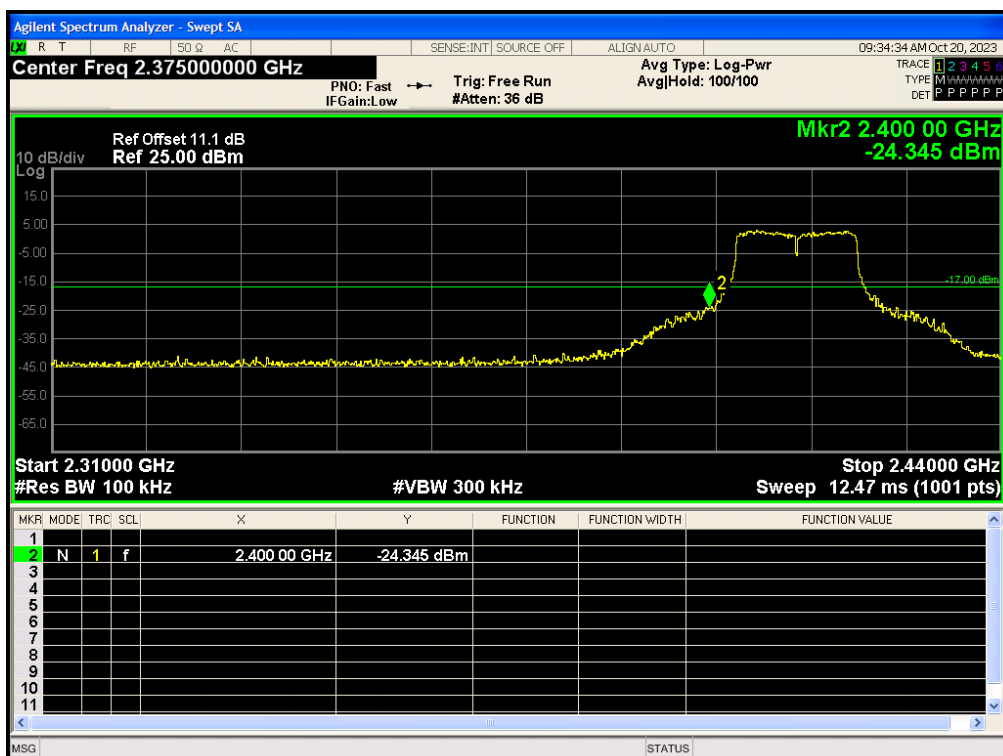

TEST REPORT

PLOTS OF OUT OF BAND CONDUCTED EMISSIONS

802.11g, Lowest Channel, Plot

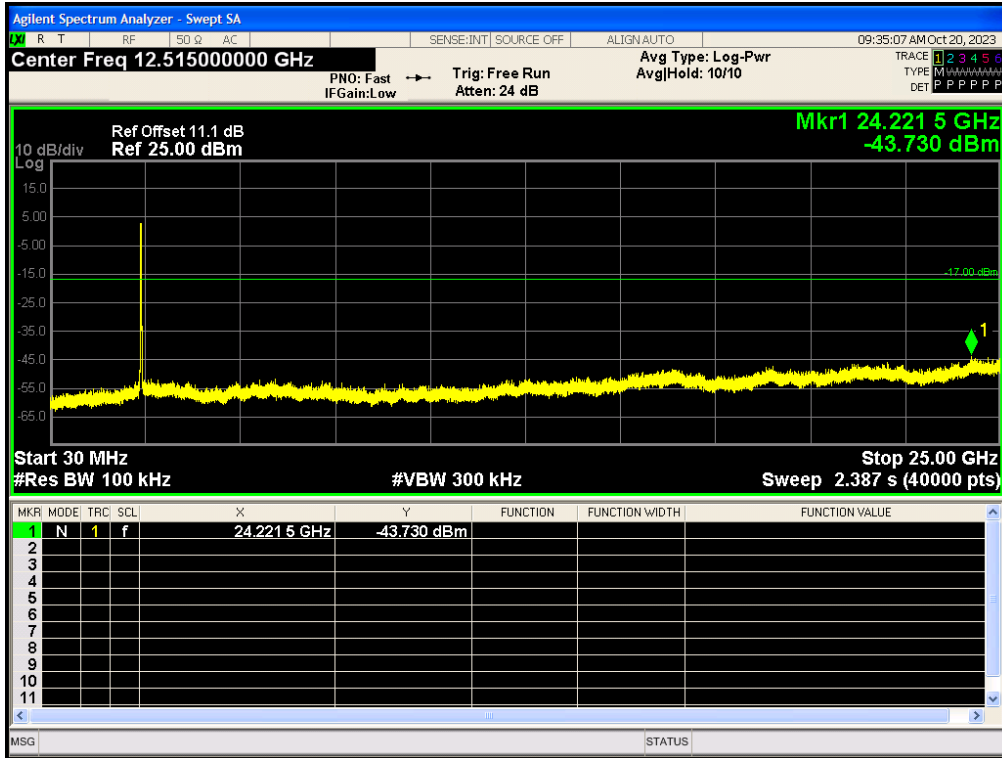

TEST REPORT

PLOTS OF OUT OF BAND CONDUCTED EMISSIONS

802.11g, Middle Channel, PSD in 100k

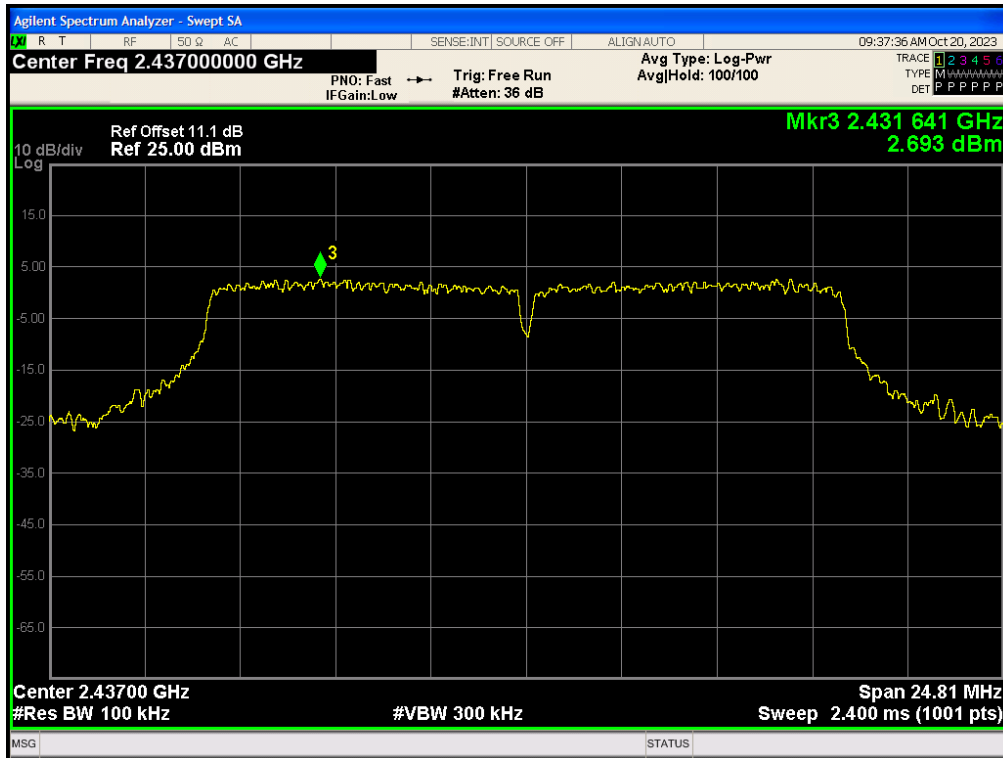

802.11g, Middle Channel, Plot

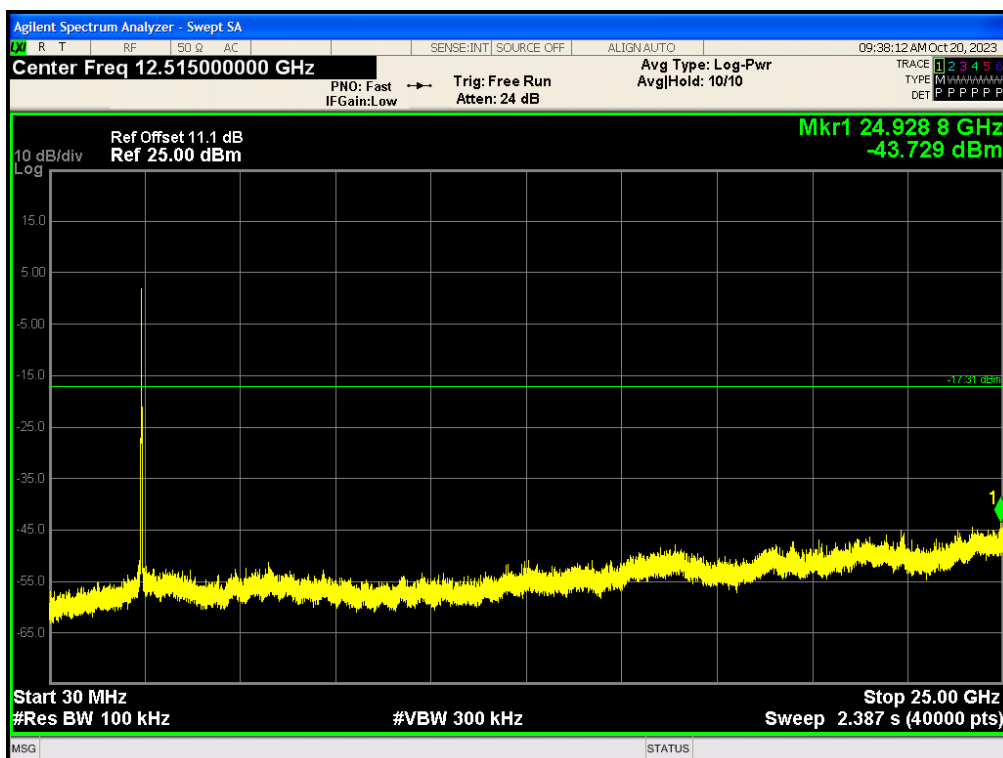

TEST REPORT

PLOTS OF OUT OF BAND CONDUCTED EMISSIONS

802.11g, Highest Channel, PSD in 100k

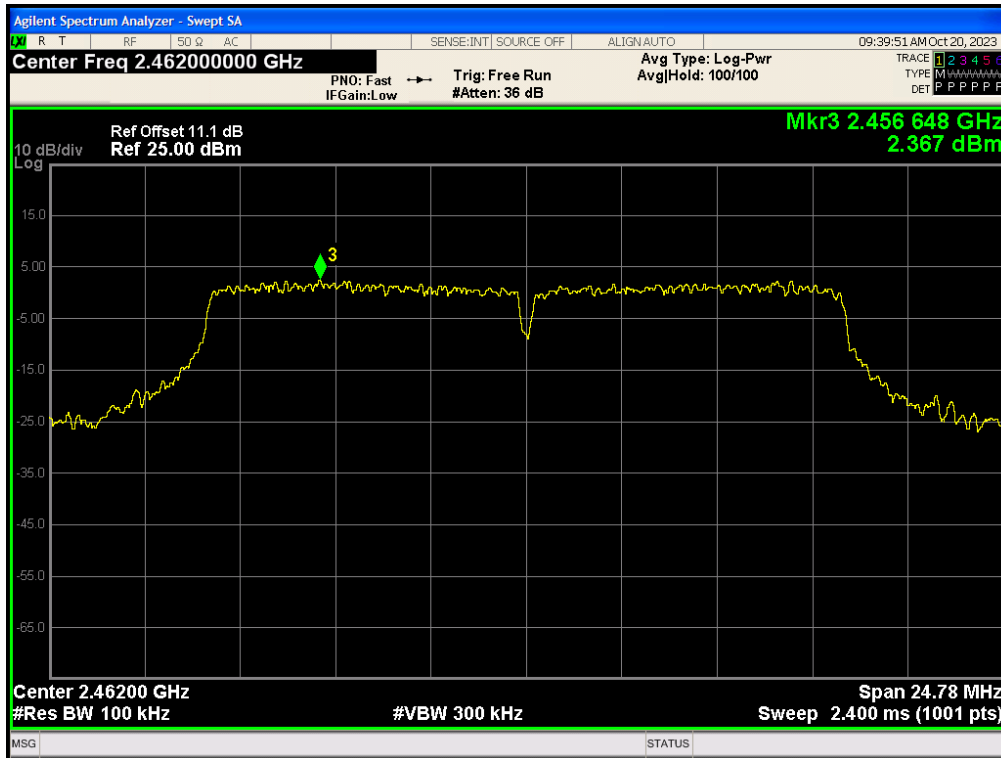

802.11g, Highest Channel, Bandedge

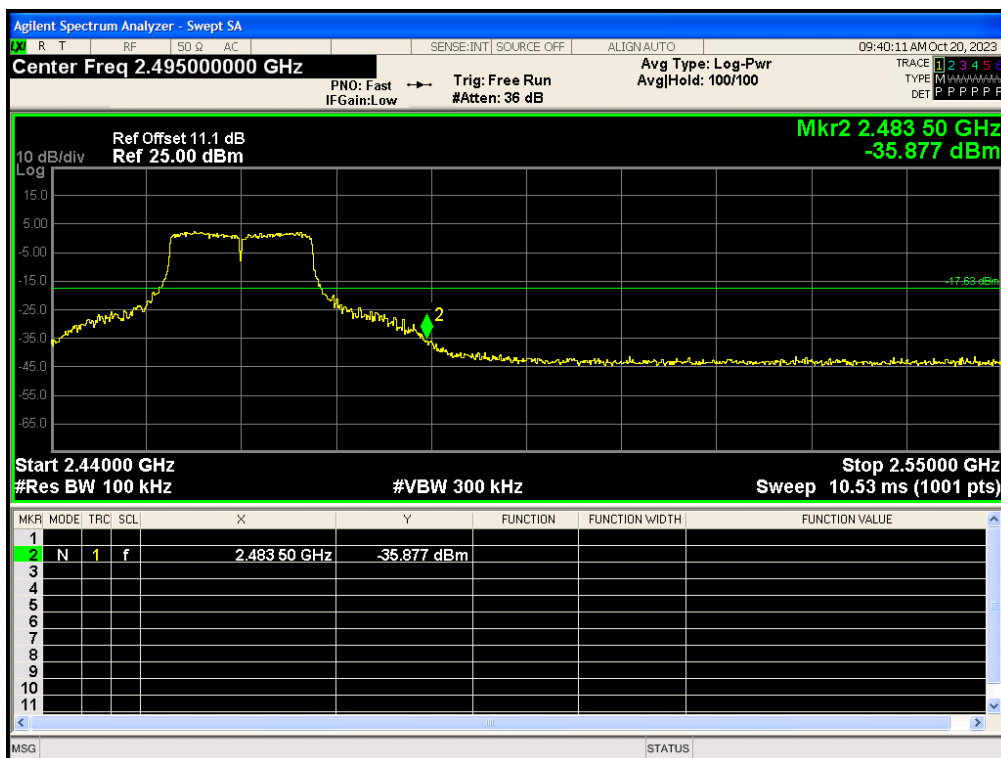

TEST REPORT

PLOTS OF OUT OF BAND CONDUCTED EMISSIONS

802.11g, Highest Channel, Plot

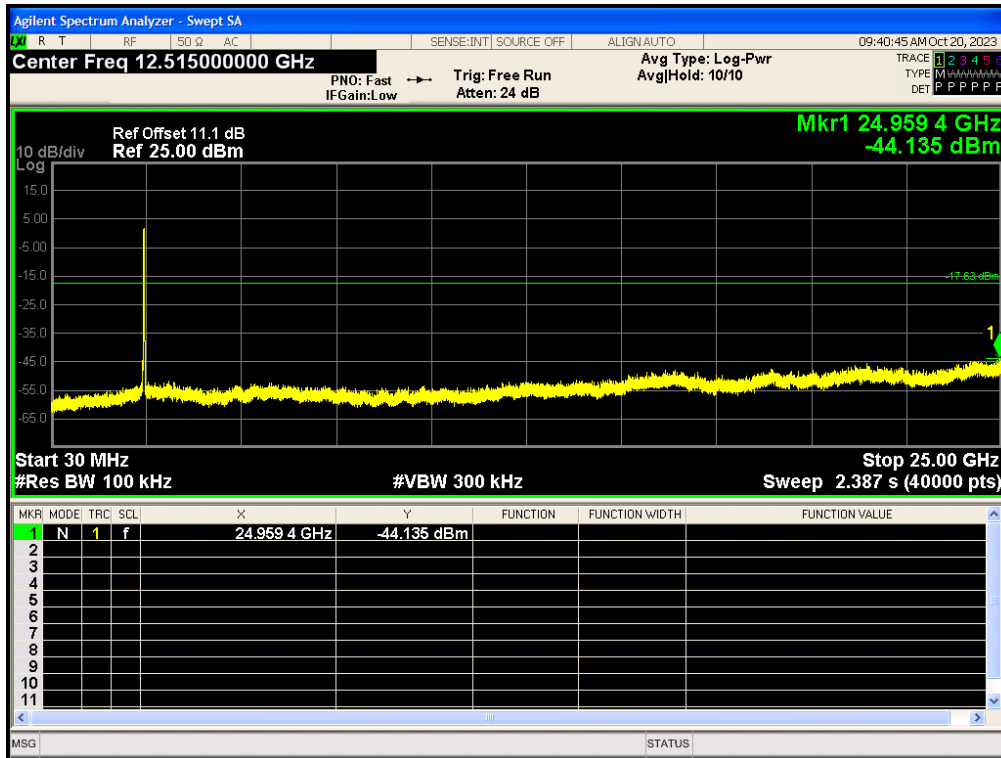

TEST REPORT

PLOTS OF OUT OF BAND CONDUCTED EMISSIONS

802. 11n (20MHz), Lowest Channel, PSD in 100k

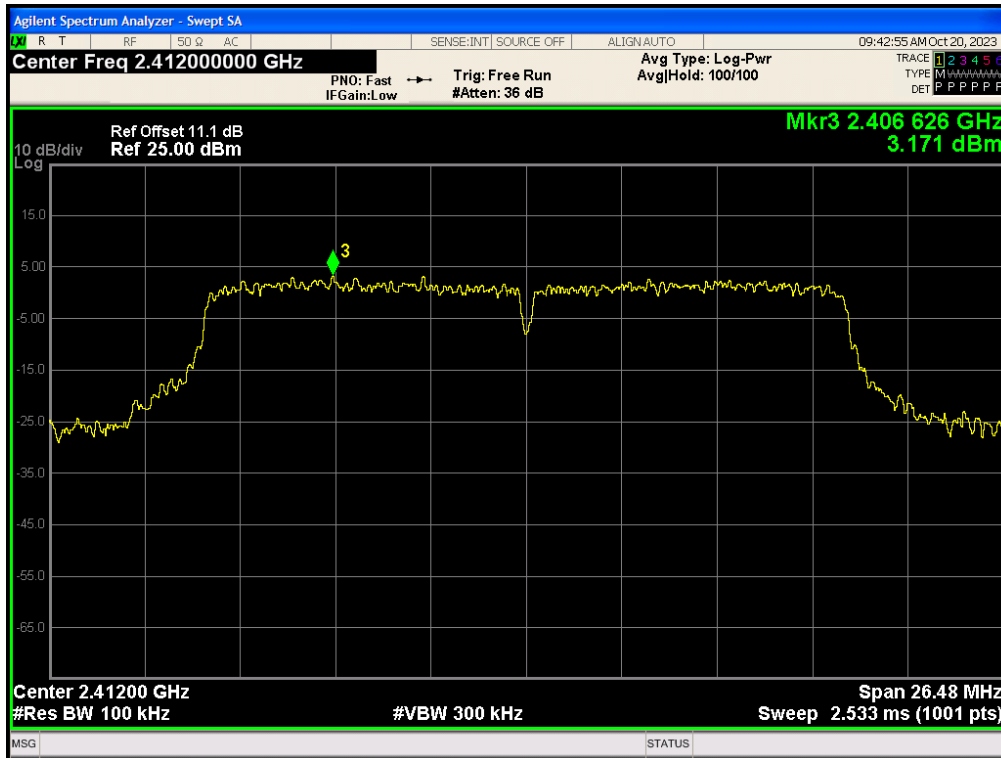

802. 11n (20MHz), Lowest Channel, Bandedge

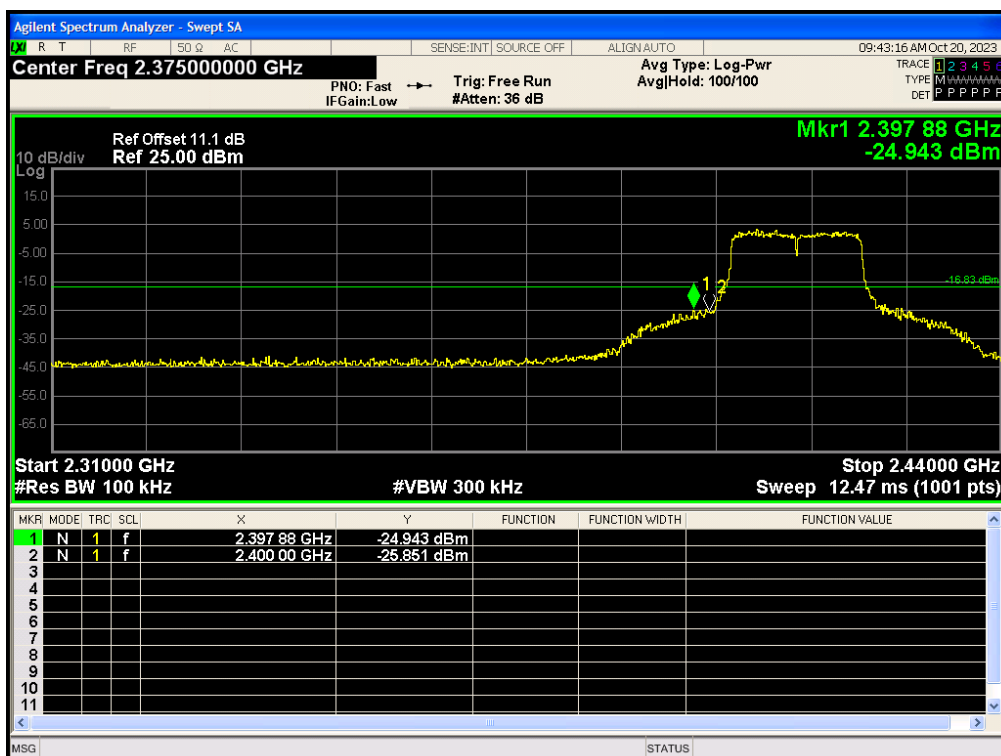

TEST REPORT

PLOTS OF OUT OF BAND CONDUCTED EMISSIONS

802.11n (20MHz), Lowest Channel, Plot

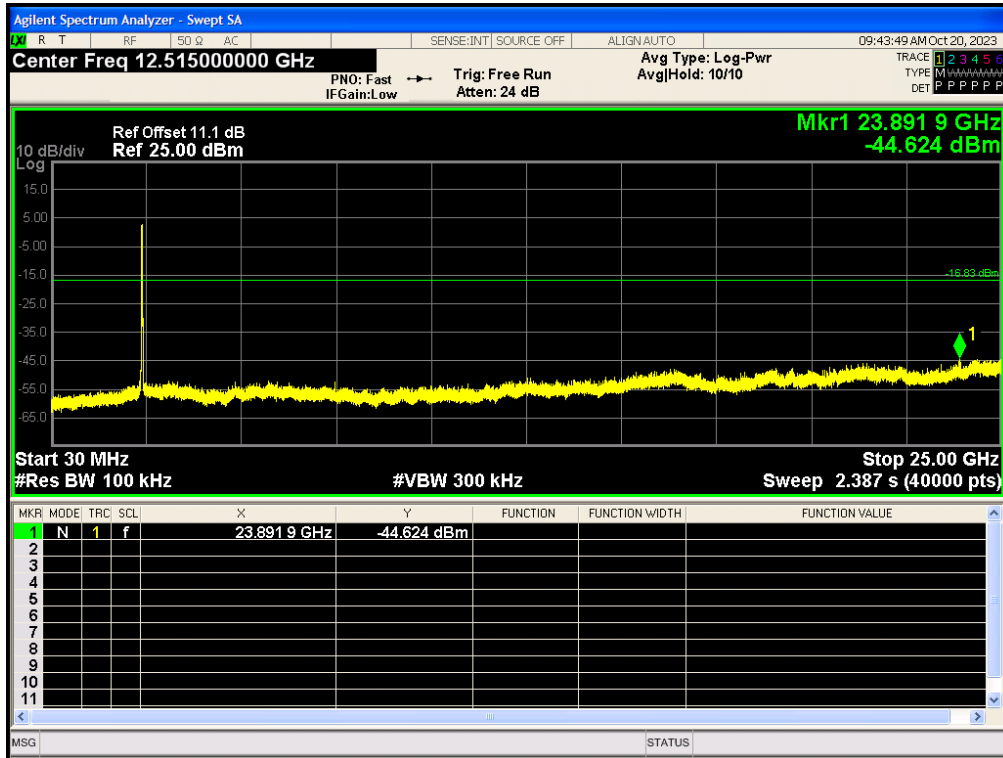

TEST REPORT

PLOTS OF OUT OF BAND CONDUCTED EMISSIONS

802.11n (20MHz), Middle Channel, PSD in 100k

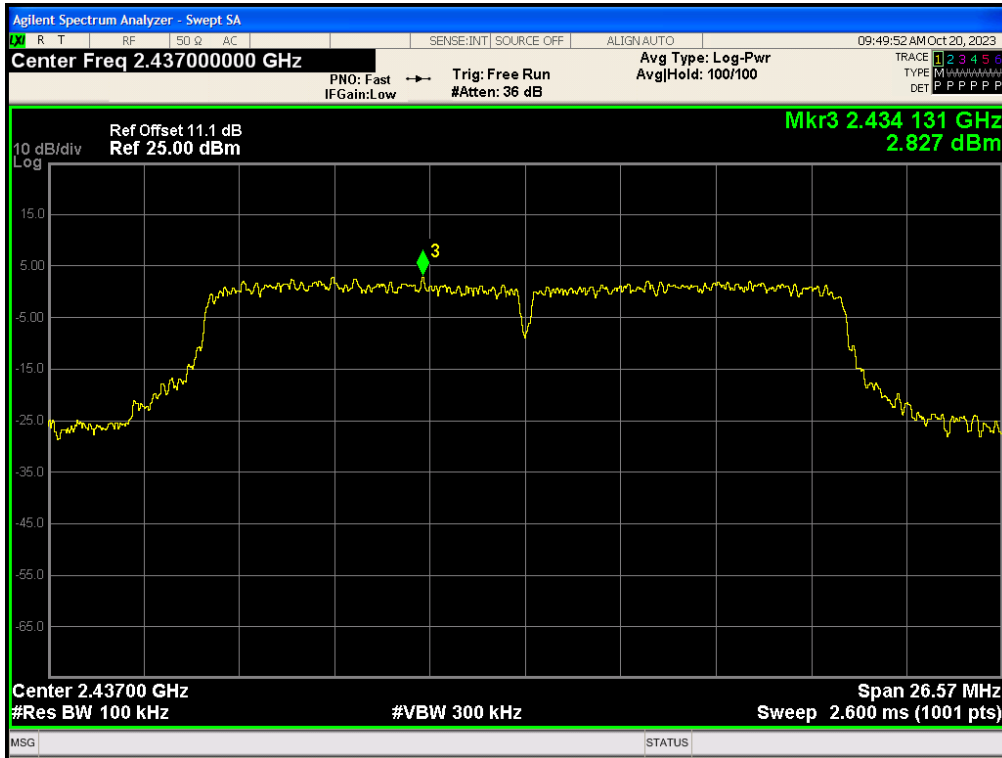

802.11n (20MHz), Middle Channel, Plot

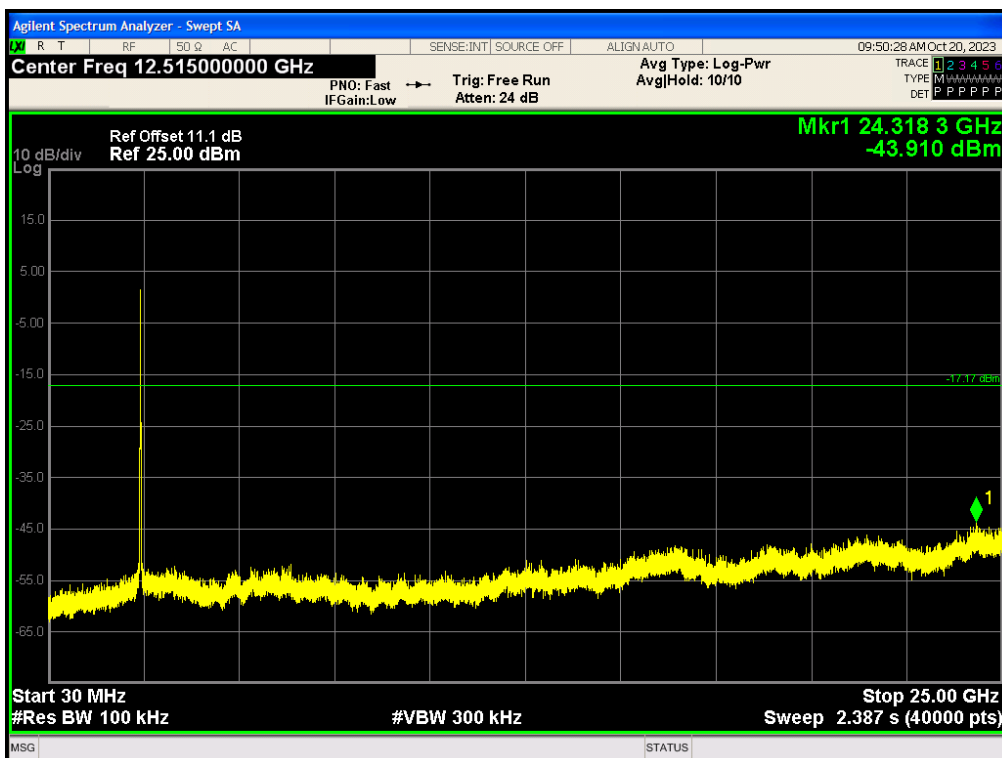

TEST REPORT

PLOTS OF OUT OF BAND CONDUCTED EMISSIONS

802.11n (20MHz), Highest Channel, PSD in 100k

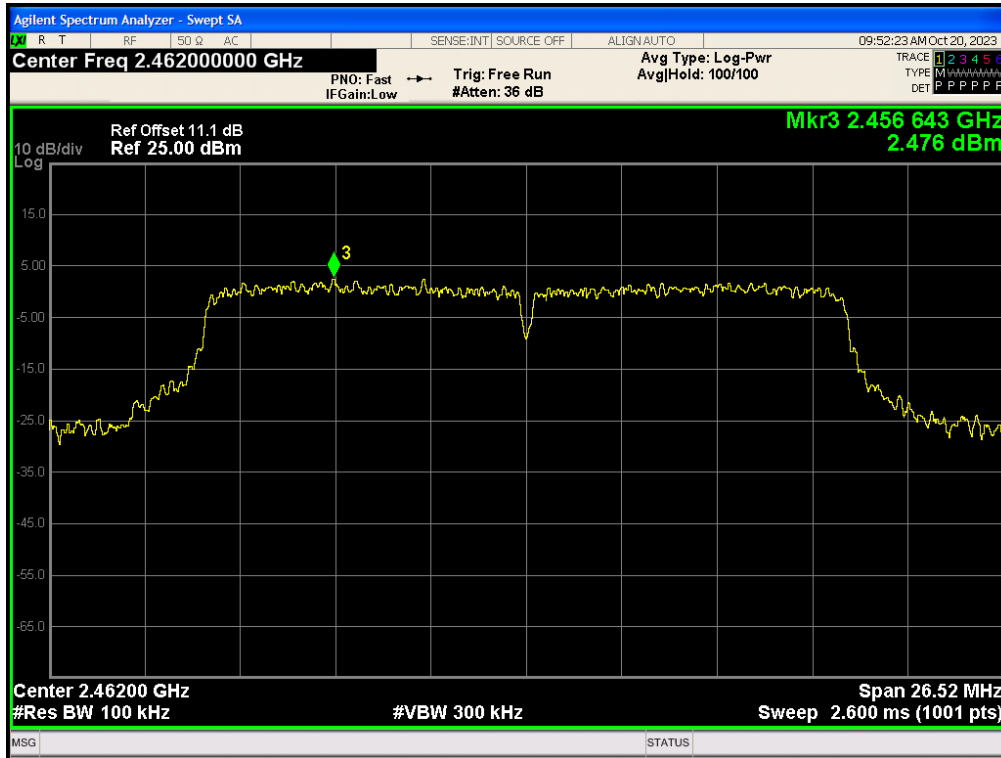

802.11n (20MHz), Highest Channel, Bandedge

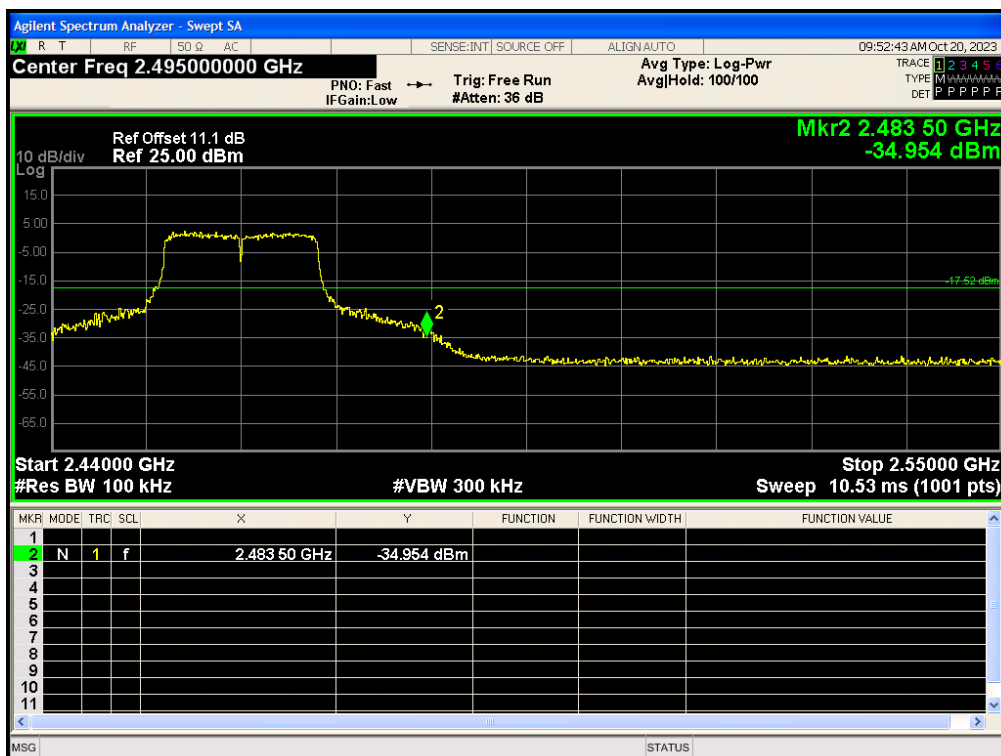

TEST REPORT

PLOTS OF OUT OF BAND CONDUCTED EMISSIONS

802.11n (20MHz), Highest Channel, Plot

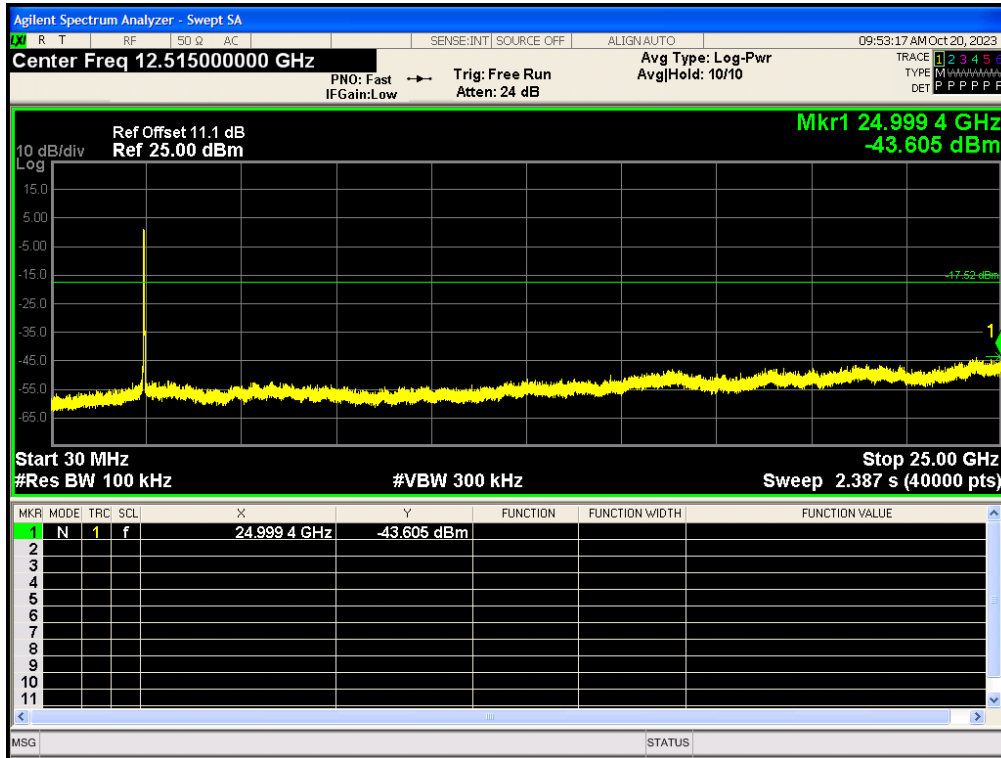

TEST REPORT

3.5 Field Strength Calculation

The field strength is calculated by adding the reading on the Spectrum Analyzer to the factors associated with preamplifiers (if any), antennas, cables, pulse desensitization and average factors (when specified limit is in average and measurements are made with peak detectors). A sample calculation is included below.

$$FS = RA + AF + CF - AG + PD + AV$$

Where	FS	=	Field Strength in dB μ V/m
	RA	=	Receiver Amplitude (including preamplifier) in dB μ V
	CF	=	Cable Attenuation Factor in dB
	AF	=	Antenna Factor in dB
	AG	=	Amplifier Gain in dB
	PD	=	Pulse Desensitization in dB
	AV	=	Average Factor in -dB

In the radiated emission table which follows, the reading shown on the data table may reflect the preamplifier gain. An example of the calculations, where the reading does not reflect the preamplifier gain, follows:

$$FS = RA + AF + CF - AG + PD + AV$$

Example:

Assume a receiver reading of 62.0 dB μ V is obtained. The antenna factor of 7.4 dB and cable factor of 1.6 dB is added. The amplifier gain of 29.0 dB is subtracted. The pulse desensitization factor of the spectrum analyzer is 0.0 dB, and the resultant average factor is -10.0 dB. The net field strength for comparison to the appropriate emission limit is 32.0 dB μ V/m. This value in dB μ V/m is converted to its corresponding level in μ V/m.

RA	=	62.0 dB μ V
AF	=	7.4 dB
CF	=	1.6 dB
AG	=	29.0 dB
PD	=	0.0 dB
AV	=	-10.0 dB
FS	=	$62.0 + 7.4 + 1.6 - 29.0 + 0.0 + -10.0 = 32.0$ dB μ V/m

$$\text{Level in } \mu\text{V/m} = \text{Common Antilogarithm } [(32.0 \text{ dB}\mu\text{V/m})/20] = 39.8 \mu\text{V/m}$$

TEST REPORT

3.6 Transmitter Radiated Emissions in Restricted Bands and Spurious Emissions

Data is included of the worst-case configuration (the configuration which resulted in the highest emission levels). A sample calculation, configuration photographs and data tables of the emissions are included.

The data on the following pages list the significant emission frequencies, the limit and the margin of compliance.

3.6.1 Radiated Emission Configuration Photograph

Worst Case Restricted Band Radiated Emission at 165.558 MHz.

The worst case radiated emission configuration photographs are saved with filename:
Setup Photos.pdf

3.6.2 Radiated Emission Data

The data in tables 1-10 list the significant emission frequencies, the limit and the margin of compliance.

Judgement – Passed by 0.7 dB margin

TEST REPORT

3.6.3 Radiated Emission Test Setup

The figure below shows the test setup, which is utilized to make these measurements.

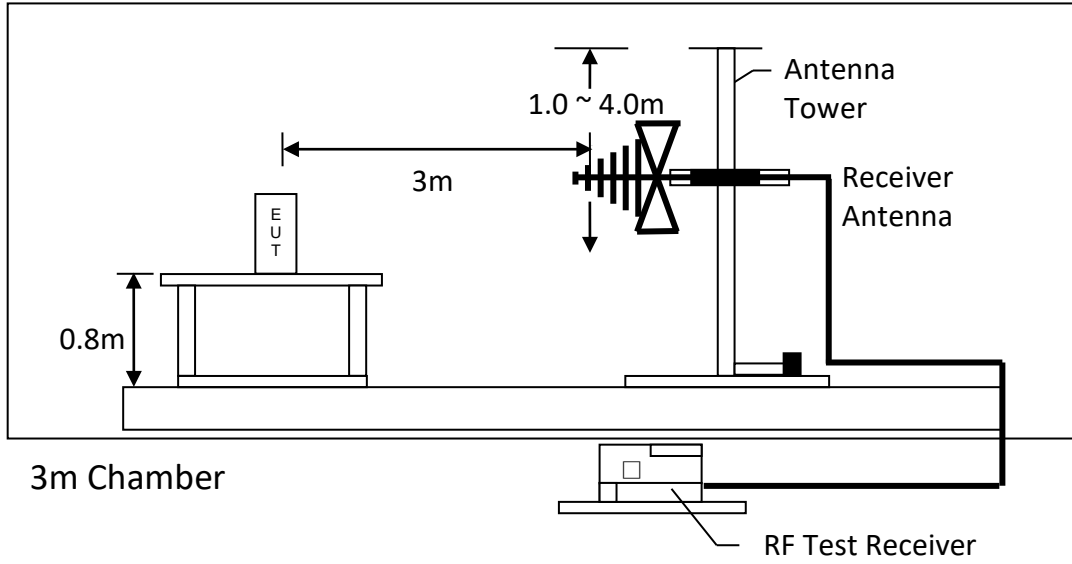

Test setup of radiated emissions up to 1GHz

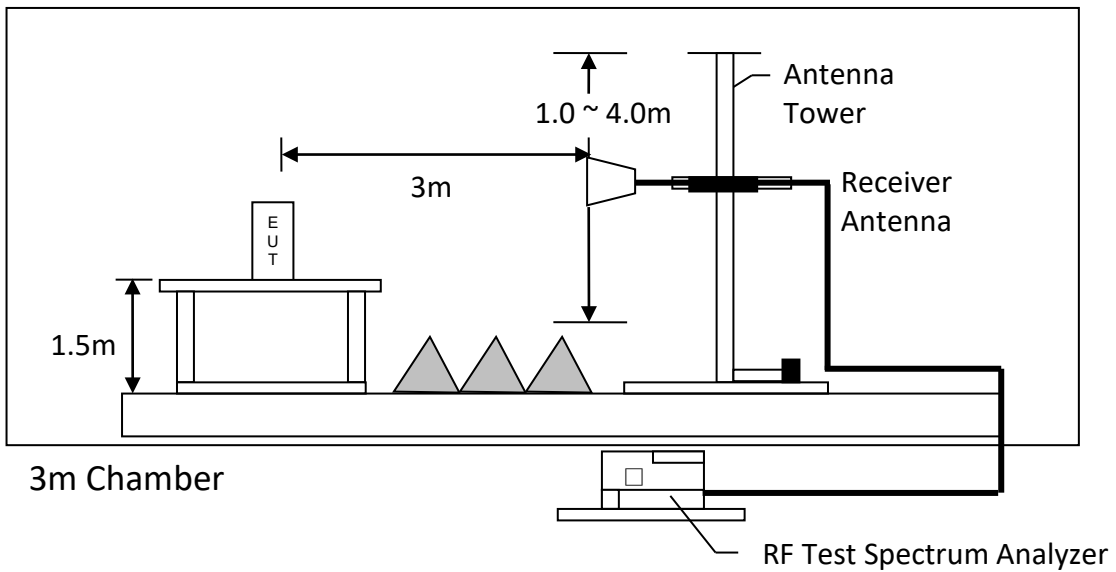

Test setup of radiated emissions above 1GHz

TEST REPORT

RADIATED EMISSION DATA

Table 1:								
IEEE 802.11b_Channel 1:								
No.	Frequency (MHz)	Reading (dBµV)	Correction factor (dB/m)	Result (dBµV/m)	Limit (dBµV/m)	Margin (dB)	Detector	Antenna Polaxis
1	4824	58.03	-1.54	56.49	74.00	-17.51	Peak	Horizontal
2	4824	41.25	-1.54	39.71	54.00	-14.29	Average	Horizontal
3	7236	40.17	2.29	42.46	74.00	-31.54	Peak	Horizontal
4	7236	28.25	2.29	30.54	54.00	-23.46	Average	Horizontal
5	4824	56.98	-1.54	55.44	74.00	-18.56	Peak	Vertical
6	4824	39.70	-1.54	38.16	54.00	-15.84	Average	Vertical
7	7236	41.00	2.29	43.29	74.00	-30.71	Peak	Vertical
8	7236	28.41	2.29	30.70	54.00	-23.30	Average	Vertical
IEEE 802.11b_Channel 6:								
1	4874	50.17	-1.47	48.70	74.00	-25.30	Peak	Horizontal
2	4874	42.08	-1.47	40.61	54.00	-13.39	Average	Horizontal
3	7311	39.56	2.32	41.88	74.00	-32.12	Peak	Horizontal
4	7311	28.18	2.32	30.50	54.00	-23.50	Average	Horizontal
5	4874	60.78	-1.47	59.31	74.00	-14.69	Peak	Vertical
6	4874	42.42	-1.47	40.95	54.00	-13.05	Average	Vertical
7	7311	40.48	2.32	42.80	74.00	-31.20	Peak	Vertical
8	7311	28.01	2.32	30.33	54.00	-23.67	Average	Vertical
IEEE 802.11b_Channel 11:								
1	4924	50.17	-1.47	48.70	74.00	-25.30	Peak	Horizontal
2	4924	34.33	-1.47	32.86	54.00	-21.14	Average	Horizontal
3	7386	39.56	2.32	41.88	74.00	-32.12	Peak	Horizontal
4	7386	27.95	2.32	30.27	54.00	-23.73	Average	Horizontal
5	4924	48.37	-1.41	46.96	74.00	-27.04	Peak	Vertical
6	4924	31.96	-1.41	30.55	54.00	-23.45	Average	Vertical
7	7386	38.89	2.36	41.25	74.00	-32.75	Peak	Vertical
8	7386	26.36	2.36	28.72	54.00	-25.28	Average	Vertical

- Notes:
1. Peak detector is used for the emission measurement.
 2. Average detector is used for the average data of emission measurement.
 3. All measurements were made at 3 meters.
 4. Negative value in the margin column shows emission below limit.
 5. Horn antenna is used for the emission over 1000MHz.
 6. Emissions within the restricted band meets the requirement of FCC Part 15 Section 15.205 / RSS-Gen Section 8.10.
 7. Correct Factor = Antenna Factor + Cable Loss - Amplifier Gain, the value was added to Original Receiver Reading by the software automatically.

TEST REPORT

RADIATED EMISSION DATA

Table 2:								
IEEE 802.11g_Channel 1:								
No.	Frequency (MHz)	Reading (dBμV)	Correction factor (dB/m)	Result (dBμV/m)	Limit (dBμV/m)	Margin (dB)	Detector	Antenna Polaxis
1	4824	49.10	-1.54	47.56	74.00	-26.44	Peak	Horizontal
2	4824	38.34	-1.54	36.80	54.00	-17.20	Average	Horizontal
3	7236	40.09	2.29	42.38	74.00	-31.62	Peak	Horizontal
4	7236	28.13	2.29	30.42	54.00	-23.58	Average	Horizontal
5	4824	48.22	-1.54	46.68	74.00	-27.32	Peak	Vertical
6	4824	38.49	-1.54	36.95	54.00	-17.05	Average	Vertical
7	7236	40.82	2.29	43.11	74.00	-30.89	Peak	Vertical
8	7236	28.52	2.29	30.81	54.00	-23.19	Average	Vertical
IEEE 802.11g_Channel 6:								
1	4874	54.45	-1.47	52.98	74.00	-21.02	Peak	Horizontal
2	4874	42.48	-1.47	41.01	54.00	-12.99	Average	Horizontal
3	7311	40.12	2.32	42.44	74.00	-31.56	Peak	Horizontal
4	7311	28.72	2.32	31.04	54.00	-22.96	Average	Horizontal
5	4874	53.77	-1.47	52.30	74.00	-21.70	Peak	Vertical
6	4874	42.34	-1.47	40.87	54.00	-13.13	Average	Vertical
7	7311	41.18	2.32	43.50	74.00	-30.50	Peak	Vertical
8	7311	28.46	2.32	30.78	54.00	-23.22	Average	Vertical
IEEE 802.11g_Channel 11:								
1	4924	50.23	-1.41	48.82	74.00	-25.18	Peak	Horizontal
2	4924	32.99	-1.41	31.58	54.00	-22.42	Average	Horizontal
3	7386	38.57	2.36	40.93	74.00	-33.07	Peak	Horizontal
4	7386	26.43	2.36	28.79	54.00	-25.21	Average	Horizontal
5	4924	49.88	-1.41	48.47	74.00	-25.53	Peak	Vertical
6	4924	32.79	-1.41	31.38	54.00	-22.62	Average	Vertical
7	7386	38.88	2.36	41.24	74.00	-32.76	Peak	Vertical
8	7386	26.36	2.36	28.72	54.00	-25.28	Average	Vertical

- Notes:
1. Peak detector is used for the emission measurement.
 2. Average detector is used for the average data of emission measurement.
 3. All measurements were made at 3 meters.
 4. Negative value in the margin column shows emission below limit.
 5. Horn antenna is used for the emission over 1000MHz.
 6. Emissions within the restricted band meets the requirement of FCC Part 15 Section 15.205 / RSS-Gen Section 8.10.
 7. Correct Factor = Antenna Factor + Cable Loss - Amplifier Gain, the value was added to Original Receiver Reading by the software automatically.

TEST REPORT

RADIATED EMISSION DATA

Table 3:								
IEEE 802.11n-HT20_Channel 1:								
No.	Frequency (MHz)	Reading (dBµV)	Correction factor (dB/m)	Result (dBµV/m)	Limit (dBµV/m)	Margin (dB)	Detector	Antenna Polaxis
1	4824	48.00	-1.54	46.46	74.00	-27.54	Peak	Horizontal
2	4824	36.34	-1.54	34.80	54.00	-19.20	Average	Horizontal
3	7236	40.67	2.29	42.96	74.00	-31.04	Peak	Horizontal
4	7236	28.08	2.29	30.37	54.00	-23.63	Average	Horizontal
5	4824	48.55	-1.54	47.01	74.00	-26.99	Peak	Vertical
6	4824	36.16	-1.54	34.62	54.00	-19.38	Average	Vertical
7	7236	40.47	2.29	42.76	74.00	-31.24	Peak	Vertical
8	7236	28.19	2.29	30.48	54.00	-23.52	Average	Vertical
IEEE 802.11n-HT20_Channel 6:								
1	4874	54.33	-1.47	52.86	74.00	-21.14	Peak	Horizontal
2	4874	38.84	-1.47	37.37	54.00	-16.63	Average	Horizontal
3	7311	40.97	2.32	43.29	74.00	-30.71	Peak	Horizontal
4	7311	27.95	2.32	30.27	54.00	-23.73	Average	Horizontal
5	4874	55.32	-1.47	53.85	74.00	-20.15	Peak	Vertical
6	4874	39.36	-1.47	37.89	54.00	-16.11	Average	Vertical
7	7311	41.82	2.32	44.14	74.00	-29.86	Peak	Vertical
8	7311	28.29	2.32	30.61	54.00	-23.39	Average	Vertical
IEEE 802.11n-HT20_Channel 11:								
1	4924	49.34	-1.41	47.93	74.00	-26.07	Peak	Horizontal
2	4924	32.21	-1.41	30.80	54.00	-23.20	Average	Horizontal
3	7386	39.62	2.36	41.98	74.00	-32.02	Peak	Horizontal
4	7386	27.09	2.36	29.45	54.00	-24.55	Average	Horizontal
5	4924	47.25	-1.41	45.84	74.00	-28.16	Peak	Vertical
6	4924	31.51	-1.41	30.10	54.00	-23.90	Average	Vertical
7	7386	38.16	2.36	40.52	74.00	-33.48	Peak	Vertical
8	7386	26.50	2.36	28.86	54.00	-25.14	Average	Vertical

- Notes:
1. Peak detector is used for the emission measurement.
 2. Average detector is used for the average data of emission measurement.
 3. All measurements were made at 3 meters.
 4. Negative value in the margin column shows emission below limit.
 5. Horn antenna is used for the emission over 1000MHz.
 6. Emissions within the restricted band meets the requirement of FCC Part 15 Section 15.205 / RSS-Gen Section 8.10.
 7. Correct Factor = Antenna Factor + Cable Loss - Amplifier Gain, the value was added to Original Receiver Reading by the software automatically.

TEST REPORT

RADIATED EMISSION DATA (BAND EDGE MEASUREMENTS)

Table 4, IEEE 802.11b

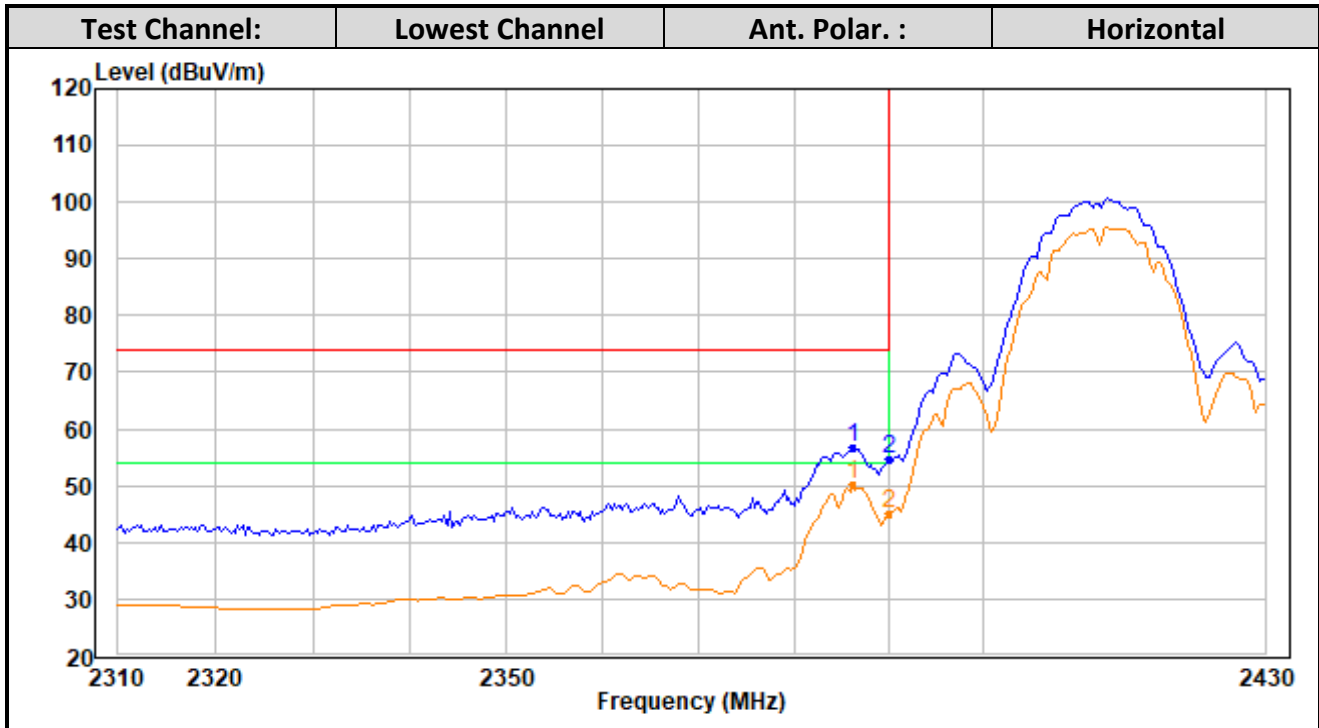

Frequency (MHz)	Peak level (dBuV/m)	Peak Limit (dBuV/m)	AV level (dBuV/m)	AV Limit (dBuV/m)	Conclusion
2386.232	56.62	74.00	50.13	54.00	Pass
2390.000	54.54	74.00	45.12	54.00	Pass

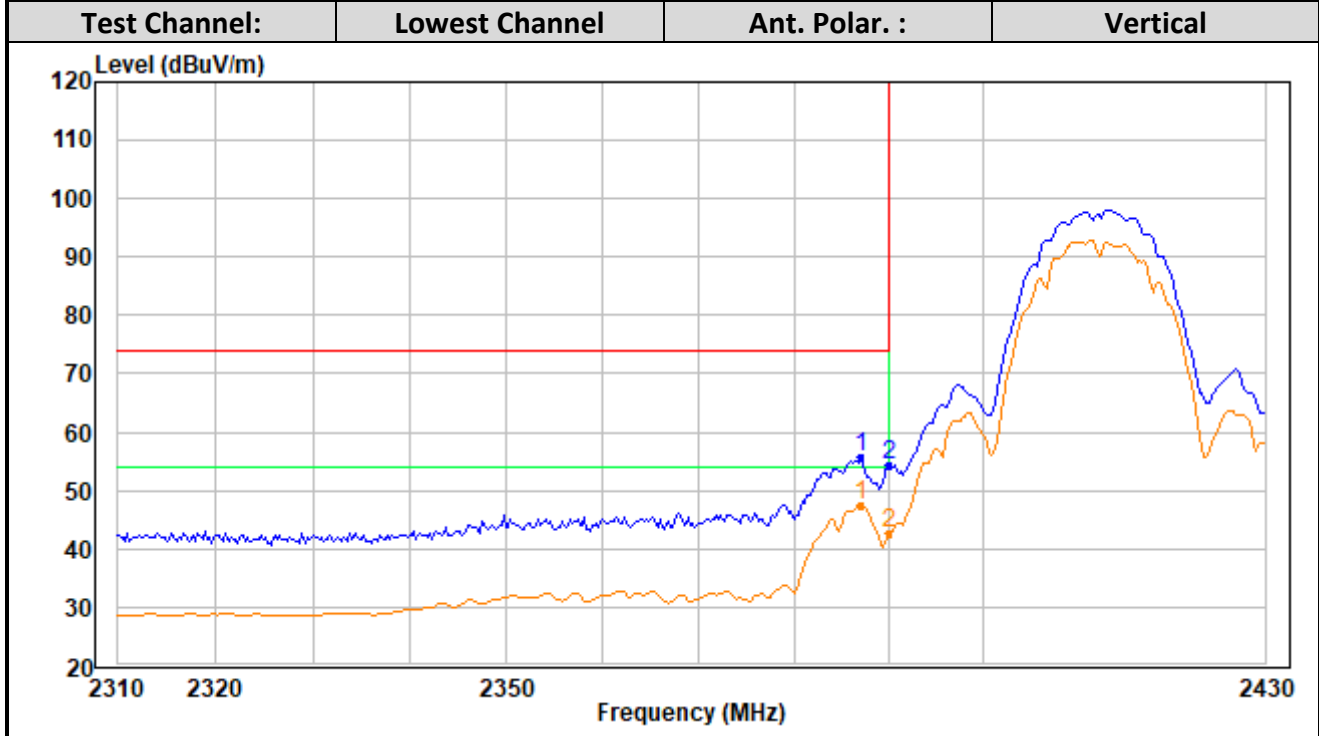

Frequency (MHz)	Peak level (dBuV/m)	Peak Limit (dBuV/m)	AV level (dBuV/m)	AV Limit (dBuV/m)	Conclusion
2386.954	55.58	74.00	47.34	54.00	Pass
2390.000	54.42	74.00	42.61	54.00	Pass

TEST REPORT

RADIATED EMISSION DATA (BAND EDGE MEASUREMENTS)

Table 5, IEEE 802.11b

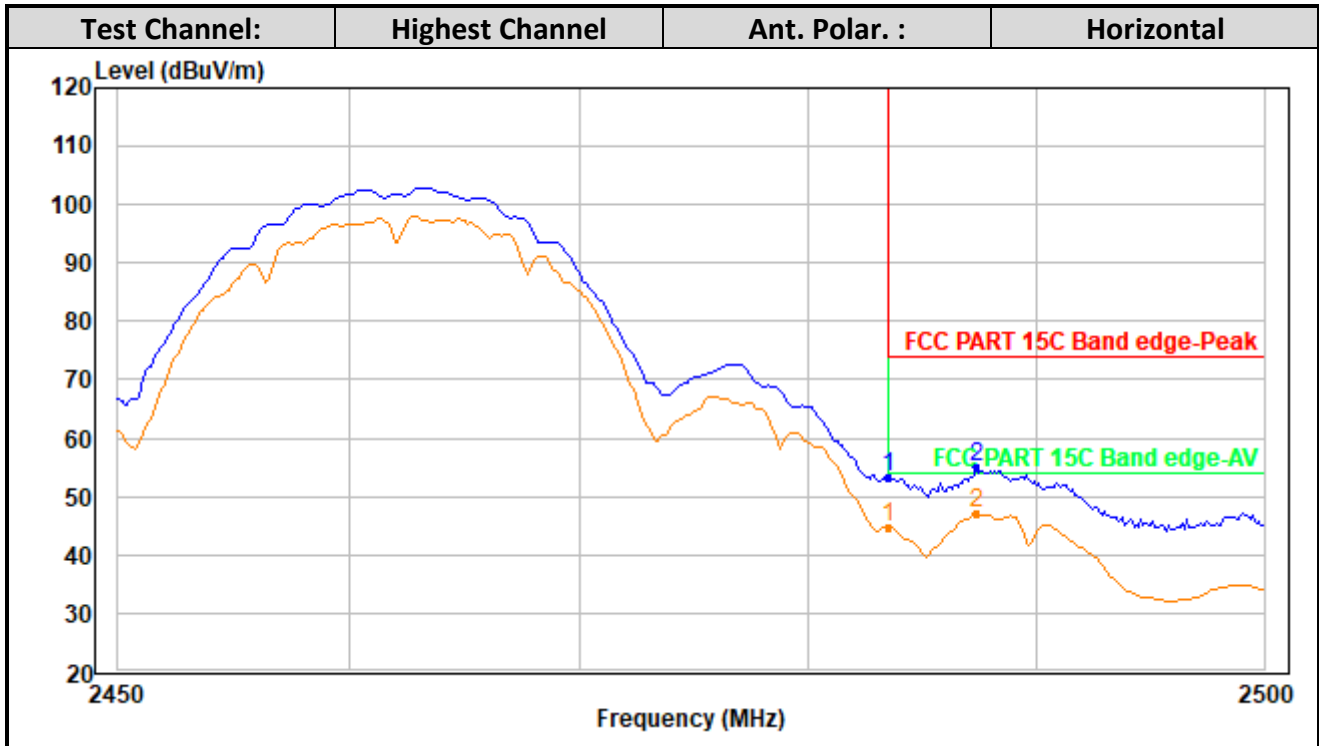

Frequency (MHz)	Peak level (dBuV/m)	Peak Limit (dBuV/m)	AV level (dBuV/m)	AV Limit (dBuV/m)	Conclusion
2483.500	53.44	74.00	44.88	54.00	Pass
2487.375	55.20	74.00	47.13	54.00	Pass

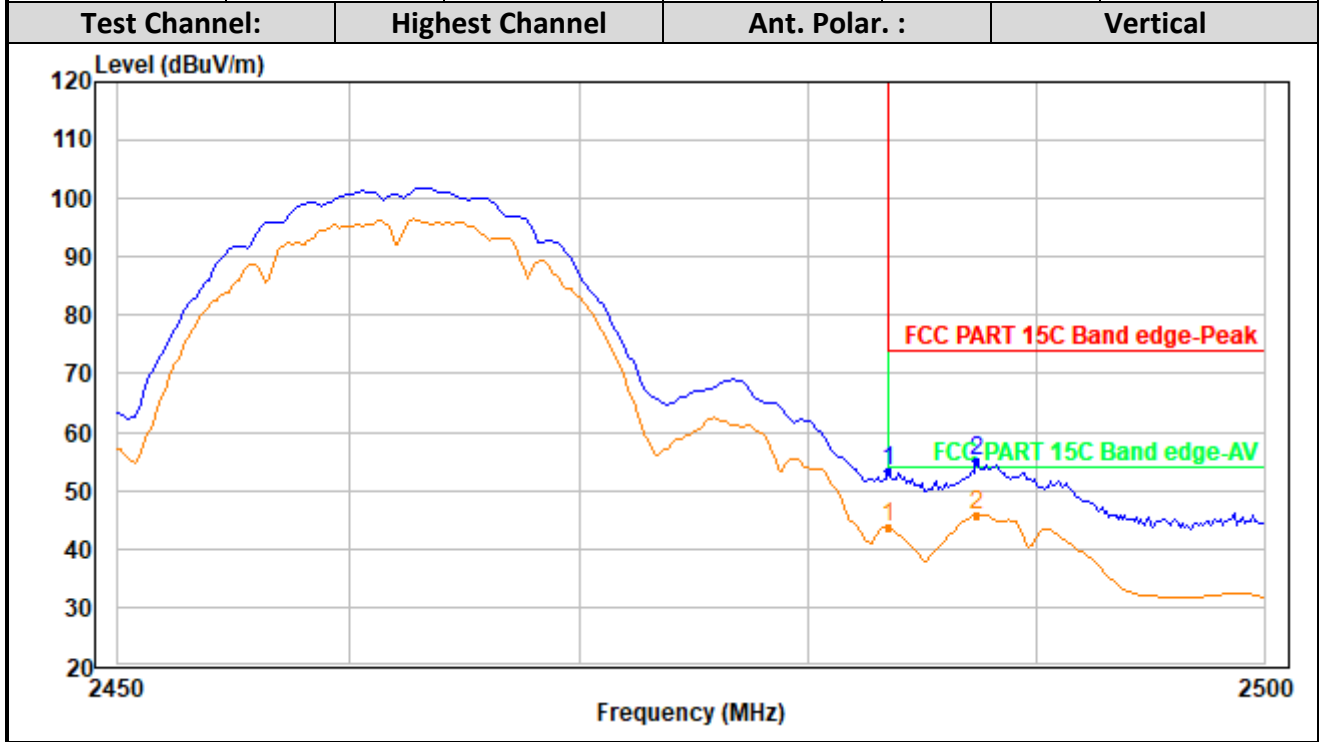

Frequency (MHz)	Peak level (dBuV/m)	Peak Limit (dBuV/m)	AV level (dBuV/m)	AV Limit (dBuV/m)	Conclusion
2483.500	53.24	74.00	43.68	54.00	Pass
2487.375	54.95	74.00	45.80	54.00	Pass

TEST REPORT

RADIATED EMISSION DATA (BAND EDGE MEASUREMENTS)

Table 6, IEEE 802.11g

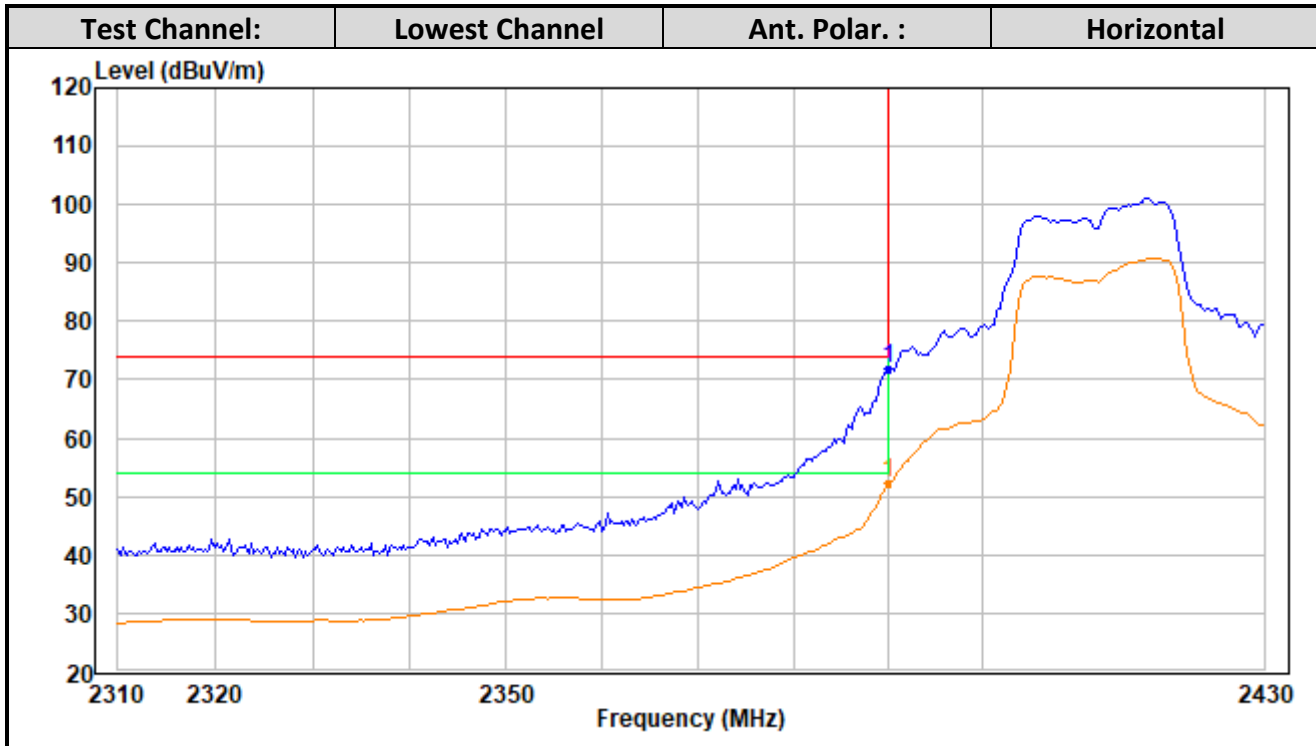

Frequency (MHz)	Peak level (dBuV/m)	Peak Limit (dBuV/m)	AV level (dBuV/m)	AV Limit (dBuV/m)	Conclusion
2390.000	71.84	74.00	52.14	54.00	Pass

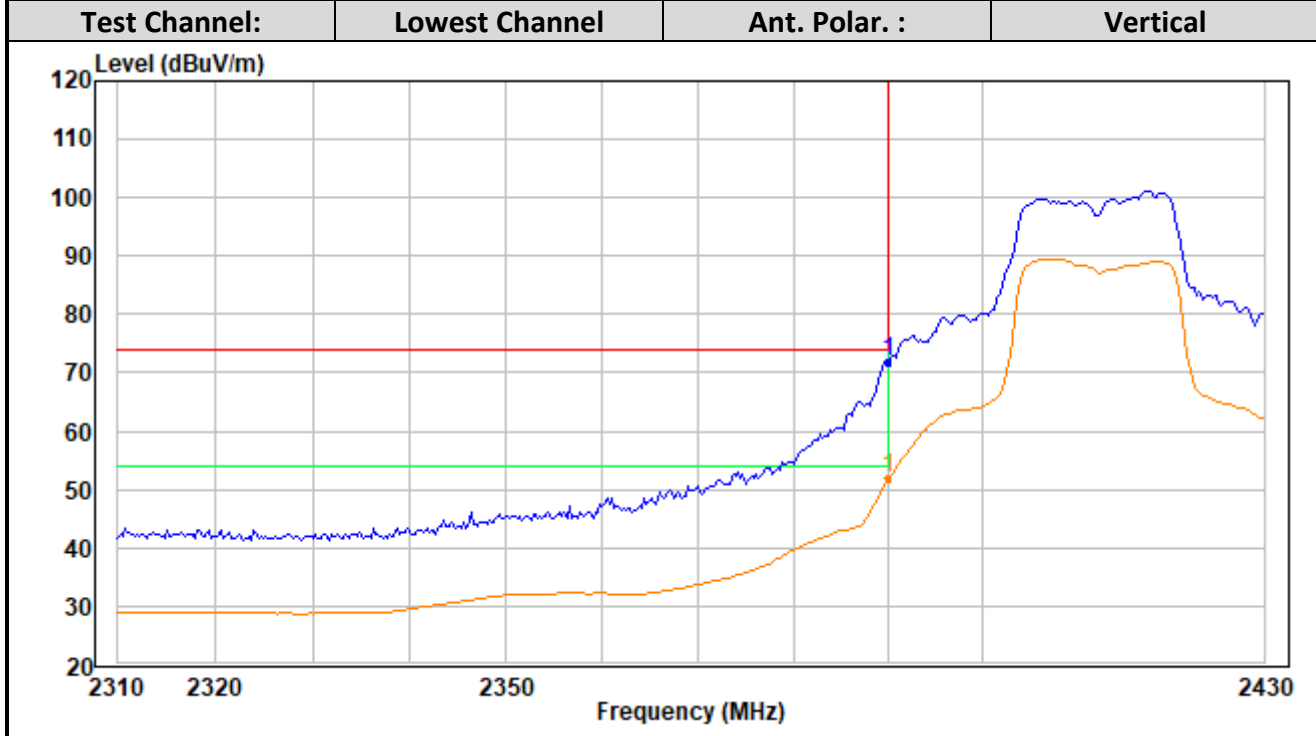

Frequency (MHz)	Peak level (dBuV/m)	Peak Limit (dBuV/m)	AV level (dBuV/m)	AV Limit (dBuV/m)	Conclusion
2390.000	71.95	74.00	51.92	54.00	Pass

TEST REPORT

RADIATED EMISSION DATA (BAND EDGE MEASUREMENTS)

Table 7, IEEE 802.11g

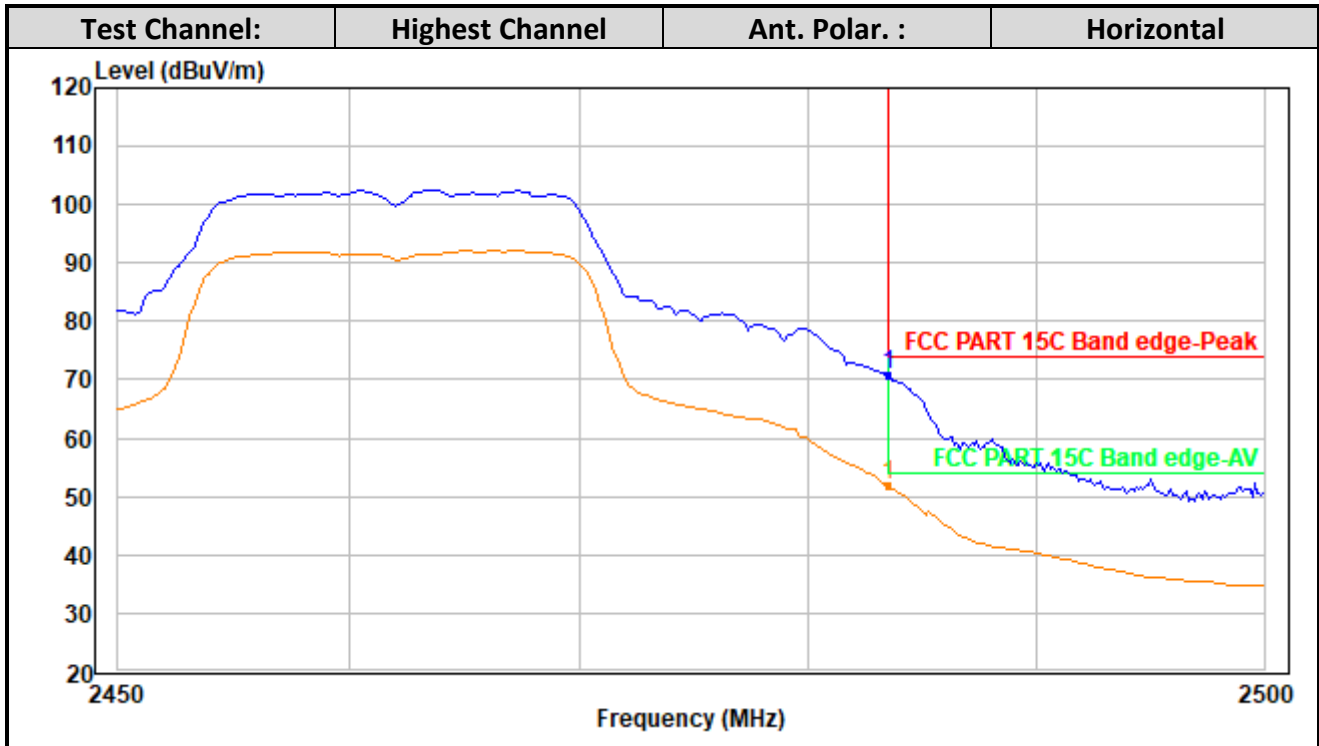

Frequency (MHz)	Peak level (dBuV/m)	Peak Limit (dBuV/m)	AV level (dBuV/m)	AV Limit (dBuV/m)	Conclusion
2483.500	70.85	74.00	51.87	54.00	Pass

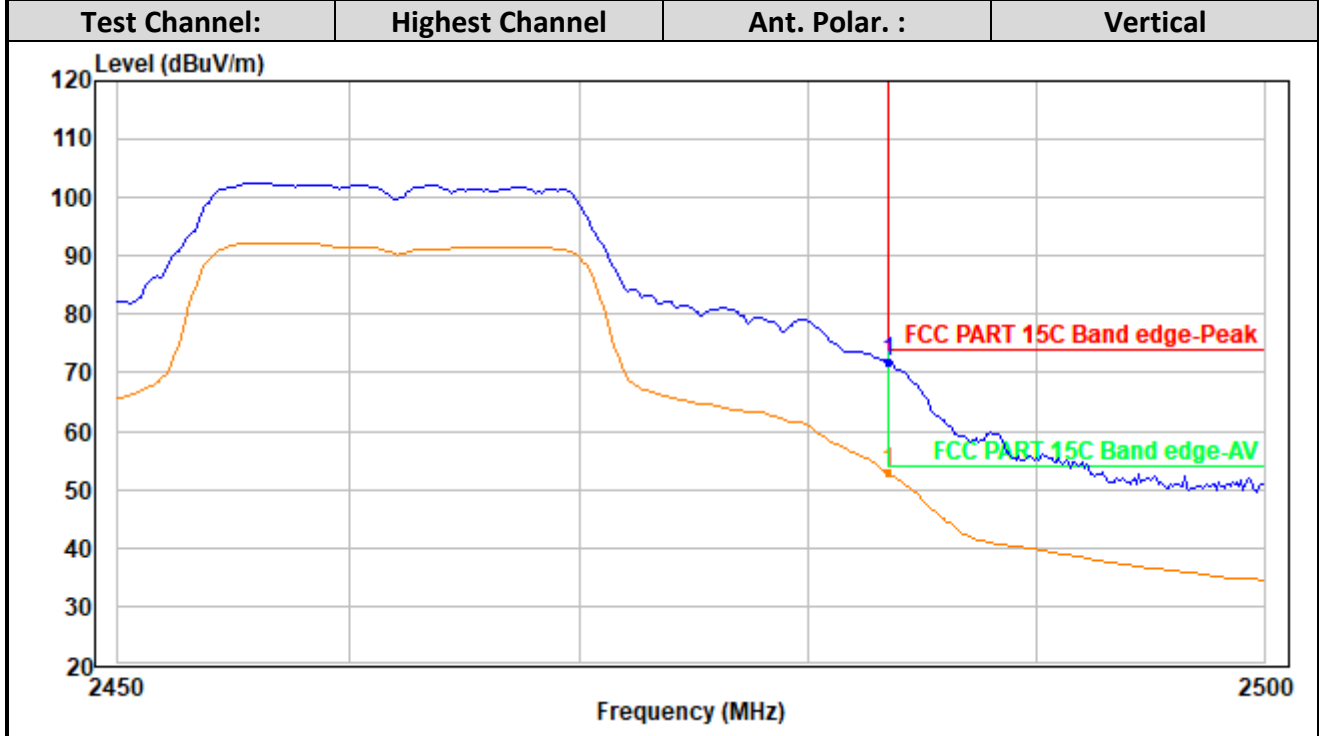

Frequency (MHz)	Peak level (dBuV/m)	Peak Limit (dBuV/m)	AV level (dBuV/m)	AV Limit (dBuV/m)	Conclusion
2483.500	71.97	74.00	52.88	54.00	Pass

TEST REPORT

RADIATED EMISSION DATA (BAND EDGE MEASUREMENTS)

Table 8, IEEE 802.11n-HT20

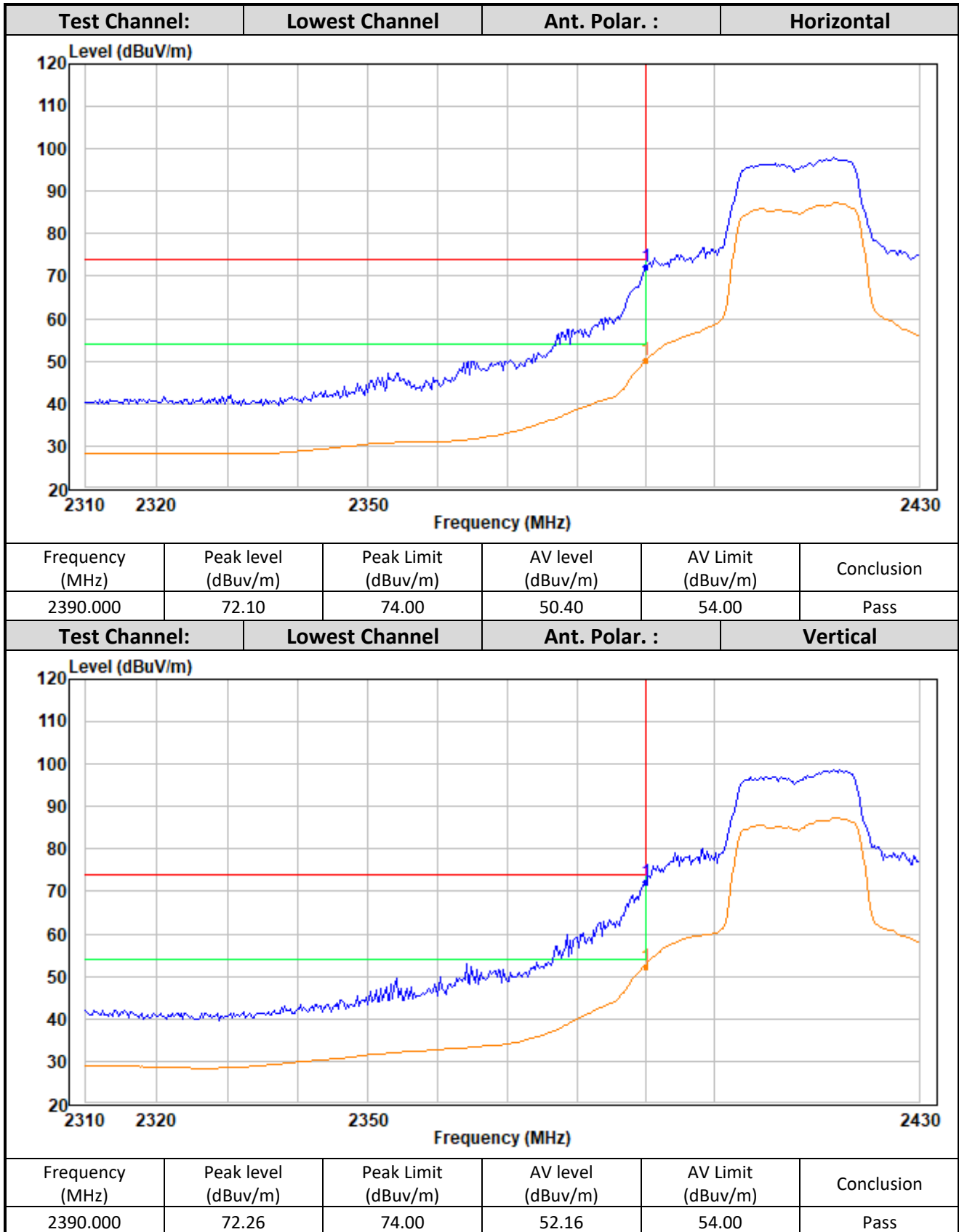

TEST REPORT

RADIATED EMISSION DATA (BAND EDGE MEASUREMENTS)

Table 9, IEEE 802.11n-HT20

Test Channel:	Highest Channel	Ant. Polar. :	Horizontal		
Frequency (MHz)	Peak level (dBuV/m)	Peak Limit (dBuV/m)	AV level (dBuV/m)	AV Limit (dBuV/m)	Conclusion
2483.500	72.45	74.00	49.48	54.00	Pass
Test Channel:	Highest Channel	Ant. Polar. :	Vertical		
Frequency (MHz)	Peak level (dBuV/m)	Peak Limit (dBuV/m)	AV level (dBuV/m)	AV Limit (dBuV/m)	Conclusion
2483.500	71.41	74.00	49.66	54.00	Pass

TEST REPORT

RADIATED EMISSION DATA

Mode: 2.4GHz Wi-Fi and Bluetooth Operating (VTPL adaptor)

Table 10

Polarization	Frequency (MHz)	Reading (dBμV)	Pre-amp (dB)	Antenna Factor (dB)	Net at 3m (dBμV/m)	Limit at 3m (dBμV/m)	Margin (dB)
H	124.939	39.6	16	14.0	37.6	43.5	-5.9
V	165.558	41.8	16	17.0	42.8	43.5	-0.7
H	374.956	31.5	16	24.0	39.5	46.0	-6.5
V	625.095	31.5	16	29.0	44.5	46.0	-1.5
H	750.104	29.9	16	30.0	43.9	46.0	-2.1
H	875.113	28.1	16	32.0	44.1	46.0	-1.9

- Notes:
1. Quasi-Peak detector are used for the emission measurement.
 2. All measurements were made at 3 meters.
 3. Negative value in the margin column shows emission below limit.
 4. Emissions within the restricted band meets the requirement of FCC Part 15 Section 15.205 / RSS-Gen Section 8.10.
 5. Measurement Uncertainty is ± 5.3 dB at a level of confidence of 95%.

TEST REPORT

RADIATED EMISSION DATA

Mode: 2.4GHz Wi-Fi and Bluetooth Operating (Mass Power adaptor)

Table 11

Polarization	Frequency (MHz)	Reading (dBμV)	Pre-amp (dB)	Antenna Factor (dB)	Net at 3m (dBμV/m)	Limit at 3m (dBμV/m)	Margin (dB)
H	167.013	38.4	16	18.0	40.4	43.5	-3.1
H	272.015	38.1	16	22.0	44.1	46.0	-1.9
V	374.956	35.3	16	24.0	43.3	46.0	-2.7
V	625.095	30.7	16	29.0	43.7	46.0	-2.3
H	750.104	30.2	16	30.0	44.2	46.0	-1.8
H	875.113	27.7	16	32.0	43.7	46.0	-2.3

- Notes:
1. Peak and Quasi-Peak detector are used for the emission measurement.
 2. All measurements were made at 3 meters.
 3. Negative value in the margin column shows emission below limit.
 4. Emissions within the restricted band meets the requirement of FCC Part 15 Section 15.205 / RSS-Gen Section 8.10.
 5. Measurement Uncertainty is ± 5.3 dB at a level of confidence of 95%.

TEST REPORT

3.7 Transmitter Duty Cycle Calculation

Not Applicable – No average factor is required

3.8 AC Power Line Conducted Emission

- Not Applicable – EUT is only powered by battery for operation.
- EUT connects to AC power line. Emission Data is listed in following pages.
- Base Unit connects to AC power line and has transmission. Handset connects to AC power line but has no transmission. Emission Data of Base Unit is listed in following pages.

3.8.1 AC Power Line Conducted Emission Configuration Photograph

Worst Case Line-Conducted Configuration at 27.4425 MHz.

The worst-case line conducted configuration photographs are attached in the Appendix and saved with filename: Setup Photos.pdf.

3.8.2 AC Power Line Conducted Emission Data

The plot(s) and data in the following pages list the significant emission frequencies, the limit and the margin of compliance.

Passed by 1.14 dB margin

3.8.3 Conducted Emission Test Setup

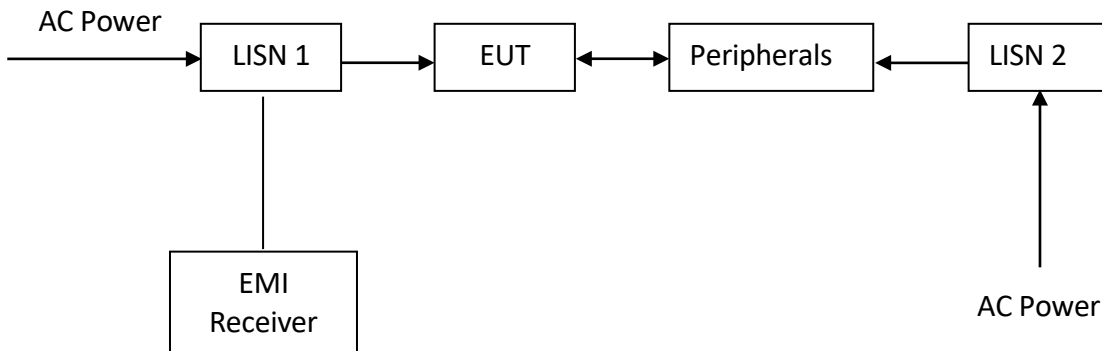

The EUT along with its peripherals were placed on a 1.0m(W)×1.5m(L) and 0.8m in height wooden table and the EUT was adjusted to maintain a 0.4 meter space from a vertical reference plane. The EUT was connected to power mains through a line impedance stabilization network (LISN), which provided 50 ohm coupling impedance for measuring instrument and the chassis ground was bounded to the horizontal ground plane of shielded room. The excess power cable between the EUT and the LISN was bundled.

All connecting cables of EUT and peripherals were moved to find the maximum emission.

TEST REPORT

CONDUCTED EMISSION

Model: D815WB
Date of Test: 10 January, 2025
Worst-Case Operating Mode: 2.4GHz Wi-Fi and Bluetooth Operating (VTPL adaptor)

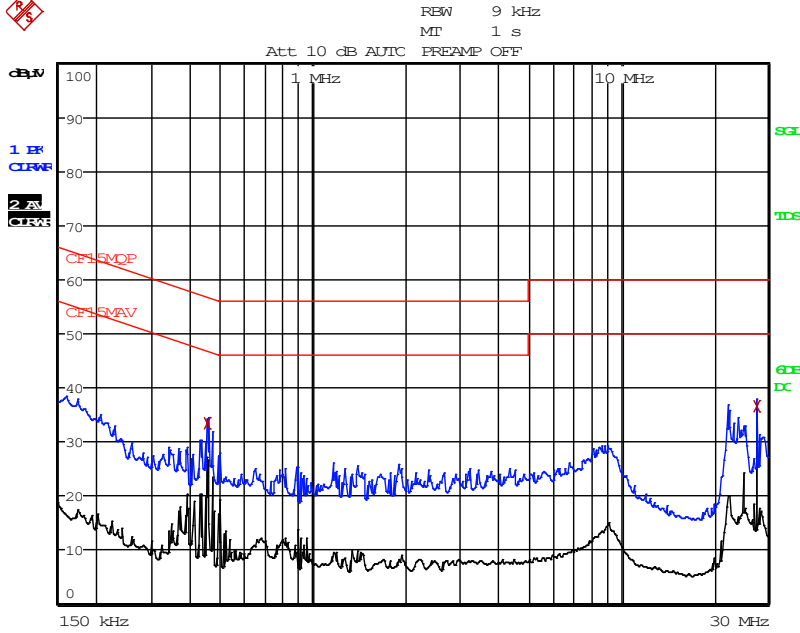

EDIT PEAK LIST (Final Measurement Results)

Trace1: CF15MOP
Trace2: CF15MAV
Trace3: ---

TRACE	FREQUENCY	LEVEL dBμV	DELTA LIMIT dB
2	CISPR Average 451.5 kHz	33.50 N	-13.34
2	CISPR Average 27.4425 MHz	36.63 L1	-13.36

Note: Measurement Uncertainty is ± 4.2 dB at a level of confidence of 95%.

TEST REPORT

CONDUCTED EMISSION

Model: D815WB
Date of Test: 10 January, 2025
Worst-Case Operating Mode: 2.4GHz Wi-Fi and Bluetooth Operating (Mass Power adaptor)

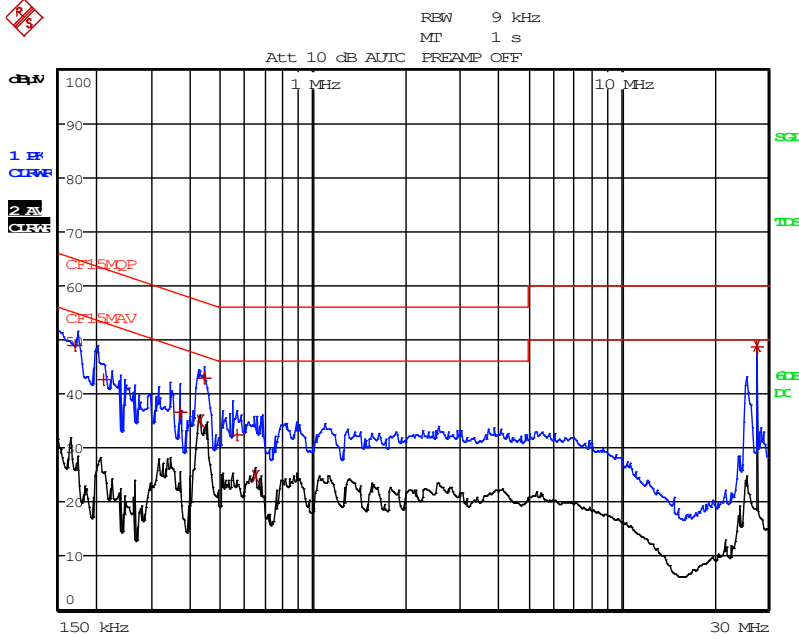

EDIT PEAK LIST (Final Measurement Results)

TRACE	FREQUENCY	LEVEL dBμV	DELTA	LIMIT dB
1 Quasi Peak	172.5 kHz	48.99	N	-15.84
1 Quasi Peak	213 kHz	42.55	L1	-20.53
1 Quasi Peak	370.5 kHz	36.66	L1	-21.82
2 CISPR Average	429 kHz	35.15	L1	-12.12
1 Quasi Peak	442.5 kHz	42.96	L1	-14.04
1 Quasi Peak	568.5 kHz	32.31	L1	-23.68
2 CISPR Average	649.5 kHz	24.82	L1	-21.17
1 Quasi Peak	27.4425 MHz	48.62	N	-11.38
2 CISPR Average	27.4425 MHz	48.85	N	-1.14

Note: Measurement Uncertainty is ± 4.2 dB at a level of confidence of 95%.

TEST REPORT**OCCUPIED BANDWIDTH**

The figure below shows the test setup, which is utilized to make these measurements.

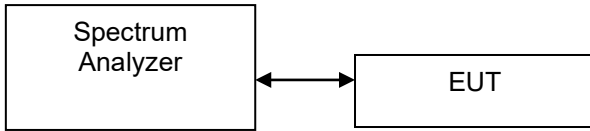

Occupied Bandwidth Results: (IEEE 802.11b)

Frequency (MHz)		Occupied Bandwidth (MHz)
Low Channel:	2412	15.095
Middle Channel:	2437	15.092
High Channel:	2462	15.088

Occupied Bandwidth Results: (IEEE 802.11g)

Frequency (MHz)		Occupied Bandwidth (MHz)
Low Channel:	2412	16.772
Middle Channel:	2437	16.815
High Channel:	2462	16.805

Occupied Bandwidth Results: (IEEE 802.11n (20MHz))

Frequency (MHz)		Occupied Bandwidth (MHz)
Low Channel:	2412	17.820
Middle Channel:	2437	17.847
High Channel:	2462	17.854

The plots of occupied bandwidth are saved as below.

TEST REPORT

PLOTS OF OCCUPIED BANDWIDTH

802.11b, Lowest Channel

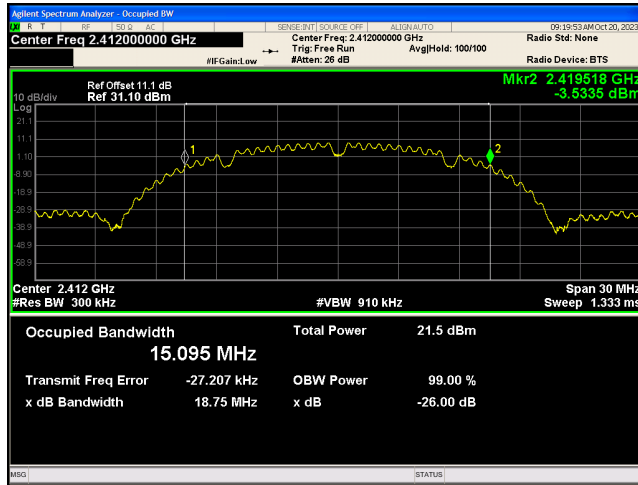

802.11b, Middle Channel

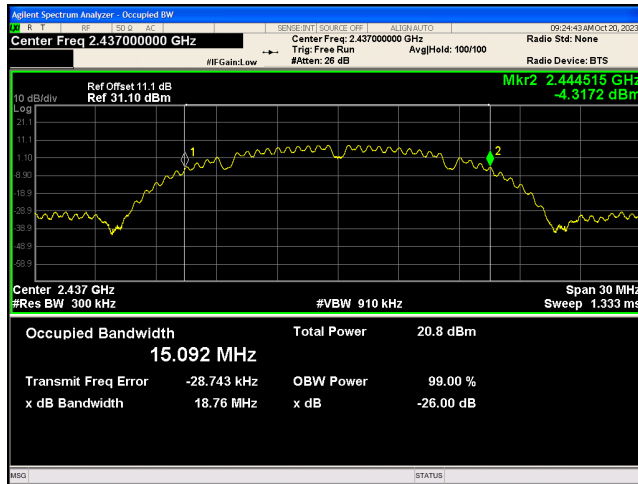

802.11b, Highest Channel

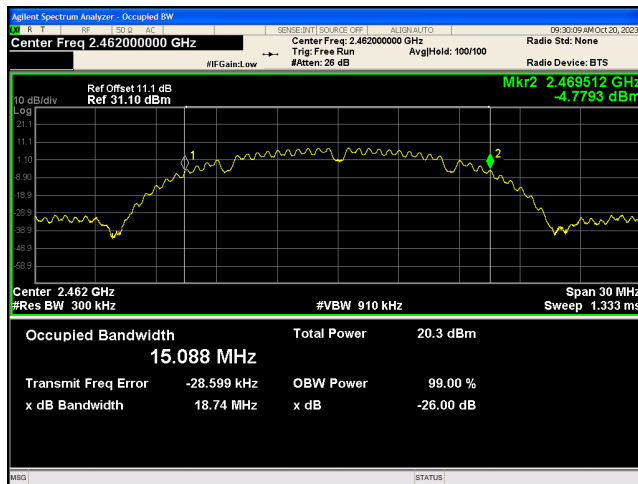

TEST REPORT

PLOTS OF OCCUPIED BANDWIDTH

802.11g, Lowest Channel

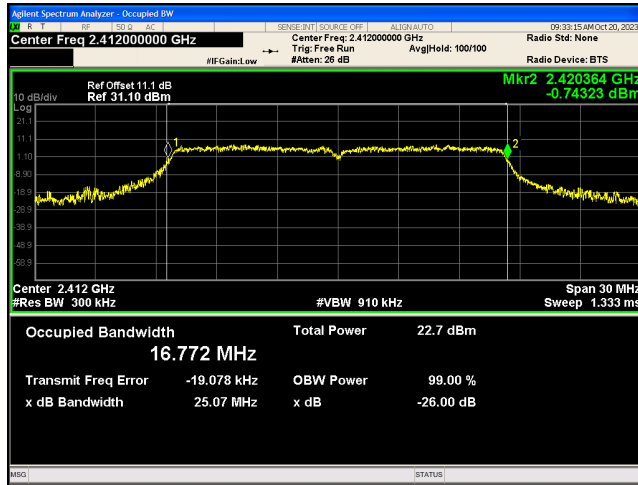

802.11g, Middle Channel

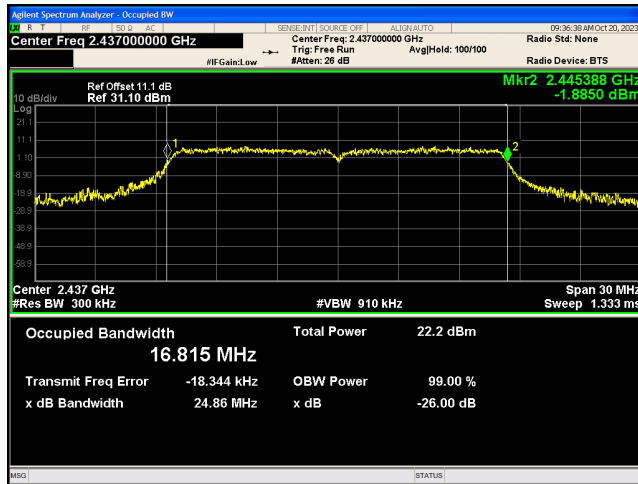

802.11g, Highest Channel

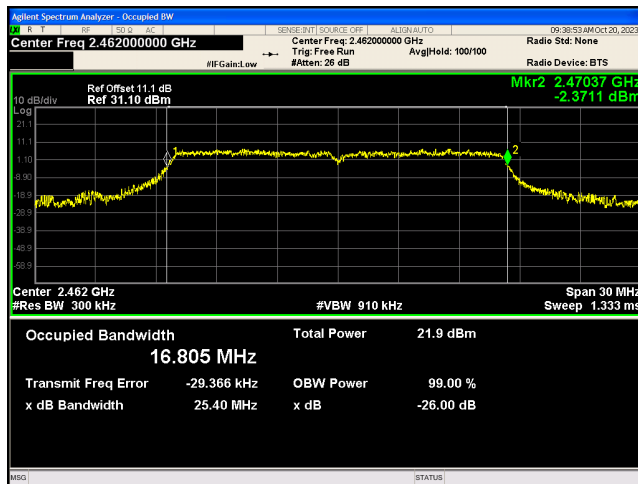

TEST REPORT

802.11n (20MHz), Lowest Channel

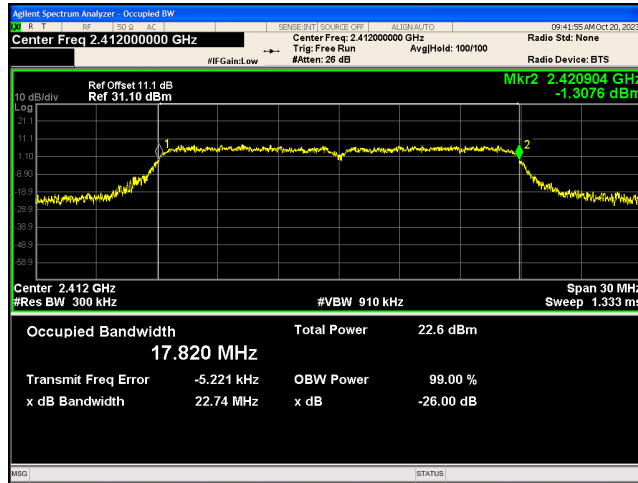

802.11n (20MHz), Middle Channel

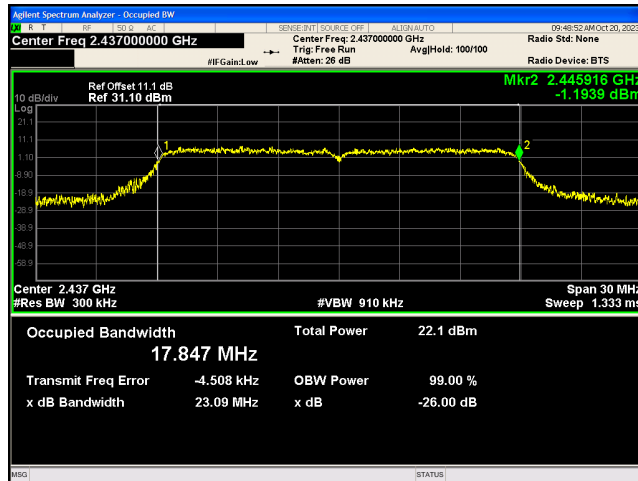

802.11n (20MHz), Highest Channel

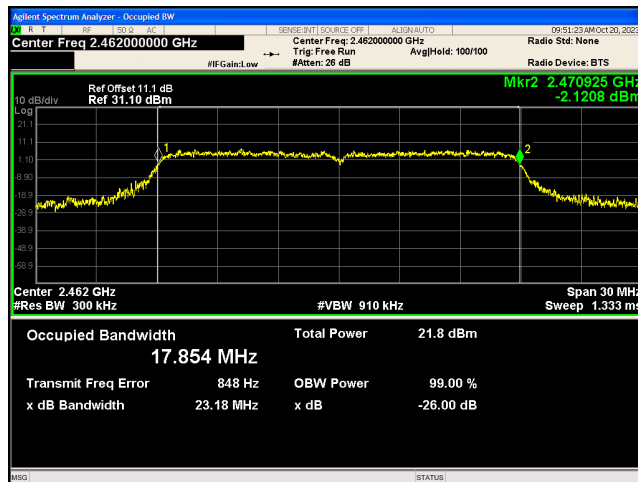

TEST REPORT

EXHIBIT 4 EQUIPMENT LIST

1) Radiated Emissions Test

Radiated Emission Test - 3M Chamber						
Used	Equipment	Manufacturer	Model No.	Serial Number	Cal. date	Cal. Due date
<input checked="" type="checkbox"/>	3m Chamber & Accessory Equipment	ETS-Lindgren	3m	Euroshiedpn-CT001270-1317	11-Nov-2023	10-Nov-2026
<input checked="" type="checkbox"/>	Broadband Antenna	ETS-Lindgren	3142E	00201566	30-Oct-2023	29-Oct-2024
<input checked="" type="checkbox"/>	6dB Attenuator	Talent	RA6A5-N-18	18103001	30-Oct-2023	29-Oct-2024
<input checked="" type="checkbox"/>	Pre-amplifier	HP	8447F	2805A02960	31-Oct-2023	30-Oct-2024
<input checked="" type="checkbox"/>	Receiver	ROHDE & SCHWARZ	ESIB26	100114	27-Oct-2023	26-Oct-2024
<input checked="" type="checkbox"/>	Double-Ridged Waveguide Horn Antenna (Pre-amplifier) 高频	ETS-LINDGREN	3117-PA	00201541	16- Apr-2023	15- Apr-2025
<input checked="" type="checkbox"/>	Pre-amplifier	ETS-Lindgren	00118385	00201874	31-Oct-2023	30-Oct-2024
<input checked="" type="checkbox"/>	Multi device Controller	ETS-Lindgren	7006-001	00160105	N/A	N/A
<input checked="" type="checkbox"/>	Test Software	Audix	e3	Software Version: 9.160323		

Equipment	EMI Test Receiver (9kHz to 26.5GHz)	Biconical Antenna (30MHz to 300MHz)	Log Periodic Antenna
Registration No.	EW-3156	EW-3242	EW-3243
Manufacturer	ROHDESCHWARZ	EMCO	EMCO
Model No.	ESR26	3110C	3148B
Calibration Date	January 31, 2024	July 30, 2024	July 30, 2024
Calibration Due Date	May 01, 2025	July 30, 2026	July 30, 2026

Equipment	Double Ridged Guide Antenna (1GHz - 18GHz)	Active Loop Antenna (H-field) (9kHz to 30MHz)	RF Preamplifier (9kHz to 6000MHz)
Registration No.	EW-0194	EW-3326	EW-3006b
Manufacturer	EMCO	EMCO	SCHWARZBECK
Model No.	3115	6502	BBV9718
Calibration Date	May 10, 2023	January 05, 2024	October 20, 2023
Calibration Due Date	May 10, 2025	July 05, 2025	April 20, 2025

TEST REPORT

EXHIBIT 4 EQUIPMENT LIST (CONT'D)

Equipment	2.4GHz Notch Filter	14m Double Shield RF Cable (9kHz - 6GHz)	RF Cable 14m (1GHz to 26.5GHz)
Registration No.	EW-3435	EW-2376	EW-2781
Manufacturer	MICROWAVE	RADIALL	GREATBILLION
Model No.	N0324413	n m/br56/bnc m 14m	SMA m/SHF5MPU /SMA m ra14m,26G
Calibration Date	October 09, 2024	October 09, 2024	January 16, 2024
Calibration Due Date	October 09, 2025	October 09, 2025	April 16, 2025

Equipment	12 metre RF Cable (1-40)GHz	Pyramidal Horn Antenna
Registration No.	EW-2774	EW-0905
Manufacturer	GREATBILLION	EMCO
Model No.	SMA m-m ra 12m 40G outdoor	3160-09
Calibration Date	January 16, 2024	December 15, 2023
Calibration Due Date	April 16, 2025	June 15, 2025

2) Conducted Emissions Test

Conducted Emission Test						
Used	Equipment	Manufacturer	Model No.	Serial Number	Cal. date	Cal. Due date
<input checked="" type="checkbox"/>	LISN	R&S	ESH2-Z5	860014/024	27-Oct-2023	26-Oct-2024
<input checked="" type="checkbox"/>	LISN	ETS-Lindgren	3816/2SH	00201088	27-Oct-2023	26-Oct-2024
<input checked="" type="checkbox"/>	ISN	Schwarzbeck	NTFM 8158	NTFM 8158#113	27-Oct-2023	26-Oct-2024
<input checked="" type="checkbox"/>	Receiver	R&S	ESR7	101181	27-Oct-2023	26-Oct-2024
<input checked="" type="checkbox"/>	Pulse Limiter	R&S	ESH3-Z2	0357.8810.54	27-Oct-2023	26-Oct-2024
<input checked="" type="checkbox"/>	Shielding room	ETS-Lindgren	843	Euroshiedpn-CT001270-1246	5-Nov-2021	4-Nov-2024
<input checked="" type="checkbox"/>	Test Software	EZ-EMC	EZ-CON	Software Version: EMC-CON 3A1.1		

Equipment	RF Cable 240cm (RG142) (9kHz to 30MHz)	Artificial Mains Network	EMI Test Receiver (9kHz to 3GHz)
Registration No.	EW-2454	EW-3360	EW-3095
Manufacturer	RADIALL	ROHDESCHWARZ	ROHDESCHWARZ
Model No.	Bnc m st / 142 / bnc mra 240cm	ENV-216	ESCI
Calibration Date	June 20, 2024	April 07, 2024	January 18, 2024
Calibration Due Date	June 20, 2025	April 07, 2025	April 18, 2025

TEST REPORT

EXHIBIT 4 EQUIPMENT LIST (CONT'D)

3) Control Software for Radiated Emission

Software Information	
Software Name	EMC32
Manufacturer	ROHDESCHWARZ
Software version	10.50.40

4) RF test

RF test						
Used	Equipment	Manufacturer	Model No.	Serial Number	Cal. date	Cal. Due date
<input checked="" type="checkbox"/>	EXA Spectrum Analyzer	KEYSIGHT	N9010A	MY51440197	2023-04-14	2024-04-13
<input checked="" type="checkbox"/>	USB Wideband Power Sensor	KEYSIGHT	U2021XA	MY55430035	2023-10-27	2024-10-26
<input checked="" type="checkbox"/>	EXG-B RF Analog Signal Generator	KEYSIGHT	N5171B	MY53051777	2023-10-27	2024-10-26
<input checked="" type="checkbox"/>	MXG X-Series RF Vector Signal Generator	KEYSIGHT	N5182B	MY51350267	2023-10-27	2024-10-26
<input checked="" type="checkbox"/>	Temp & Humidity chamber	Votisch	VT4002	58566133290020	2023-04-14	2024-04-13

END OF TEST REPORT