



User's manual

MS2015

DECT 6.0 4-line corded

Small Business System Deskset



Congratulations

on your purchase of this AT&T product. Before using this AT&T product, please read the **Important safety information** on pages 68-69 of this manual.

Please thoroughly read this user's manual for all the feature operations and troubleshooting information necessary to install and operate your new AT&T product. You can also visit our website at **www.telephones.att.com** or call **1 (800) 222-3111**. In Canada, dial **1 (866) 288-4268**.

Model number: MS2015

Type: DECT 6.0 4-line corded/cordless small business system deskset

Serial number: _____

Purchase date: _____

Place of purchase: _____

Both the model and serial numbers of your AT&T product can be found on the bottom of the deskset.

Save your sales receipt and original packaging in case it is necessary to return your telephone for warranty service.



Telephones identified with this logo have reduced noise and interference when used with most T-coil equipped hearing aids and cochlear implants. The TIA-1083 Compliant Logo is a trademark of the Telecommunications Industry Association. Used under license.

Parts checklist

Check to make sure the telephone package includes the following items:

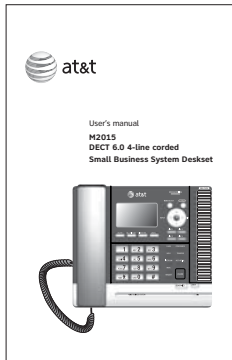

User's manual

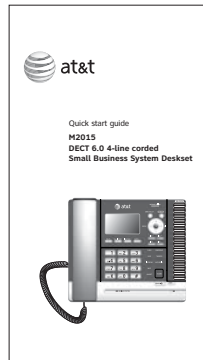

Quick start guide



Deskset



Handset with coiled cord installed

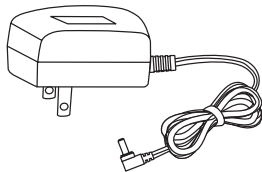

Deskset power adapter

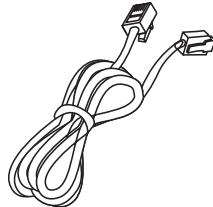

Ethernet cable



Wall mount bracket

User's manual

MS2015

DECT 6.0 4-line corded Small Business System Deskset



Table of contents

Getting started

Quick reference guide	1	Menu settings.....	16
Introduction.....	4	Set extension number.....	17
Planning your system.....	5	Prime line	18
Installation.....	6	Network setup	19
Table/desktop installation.....	7	Network info	21
To mount the deskset on the wall .	8	Telephone settings	
Wall mount installation.....	10	Telephone setup	22
Wall mount to tabletop		Ringer volume.....	22
installation.....	10	Ringer tone.....	23
Adding and registering desksets.....	11	Delay ring.....	24
To register a deskset to your		Set Date/Time.....	25
MS2085 main console	11	One Touch.....	26
Adding and registering a cordless		Assign a one-touch entry.....	26
handset.....	12	Review the one-touch entry	28
To register a cordless handset to		Edit the one-touch key.....	28
your MS2015 deskset.....	12	Delete an one-touch key.....	29
Adding and registering a cordless		LCD Language.....	30
headset.....	13	Area codes.....	31
To register a cordless headset to		Key Tone	32
your MS2015 deskset.....	13	LCD contrast	32
Deregistering cordless handset or		Dial mode	33
cordless headset.....	14	AUTO-MUTE.....	33
To deregister the cordless handset		Hold reminder	34
or headset from the MS2015		Voice announce.....	34
deskset	14	Phone rename.....	35
Adding a corded headset.....	15	Set default.....	35
To add a corded headset to the			
deskset	15		
System setup.....	16		

Customer support	35	End a page	50
Telephone operation		Directory	
Telephone basic operation	36	About the directory.....	51
Line indicators.....	36	Capacity	51
Making a call.....	36	Create directory entries	52
On hook dialing (predialing).....	37	Create a new directory entry	52
Using the speakerphone.....	37	Review directory entries	52
Answering a call	37	Search directory.....	53
Temporary ringer silencing.....	37	Search by name	53
Redial.....	38	Dial, delete or edit entries.....	54
Auto-redial.....	39	Display dial.....	54
Options while on calls.....	40	Delete an entry.....	54
Call waiting.....	40	Edit an entry	54
Volume control.....	40	Caller ID operation.....	55
Mute	41	Memory match.....	55
Temporary tone dialing	41	Missed (new) calls indicator.....	55
Hold.....	42	Review the caller ID information..	55
Switching between lines.....	42	View dialing options.....	56
Call privacy.....	43	Dial a call history entry.....	56
Chain dialing.....	44	Delete entries.....	56
Join a call in progress.....	45	Save a call history entry to the	57
Conference calls	45	directory.....	57
Intercom.....	47	Reasons for missing caller ID	58
Make an intercom call to an		information.....	58
extension.....	47	Answering system	
Answer an intercom call.....	47	Private mailbox setup	59
End an intercom call.....	47	Private mailbox on/off.....	59
Answer an incoming call during		Private mailbox delay.....	59
an intercom call.....	47	Announcement	59
Call transfer	48	Delete all private mailbox	
Blind transfer.....	48	messages.....	60
Transfer a call and speak to the		Record memo.....	60
receiving party.....	49	Call intercept.....	61
Answer a transferred call.....	49	Answering system setup.....	62
Voice page	50	Remote access code.....	62
Page a single device.....	50	Message alert.....	62
Page all devices	50	Message Length	63
Answer a page.....	50	Call screening.....	63

Record time.....	63
Answering system operation.....	64
New message indication.....	64
Message playback.....	64
Options during playback.....	64
Remote access.....	65
Maintenance.....	67
Important safety information	68
FCC part 68 and ACTA.....	70
FCC part 15.....	71
Limited warranty.....	72
Technical specifications	74

Quick reference guide

CALL HISTORY

Press to view caller ID information (page 55).

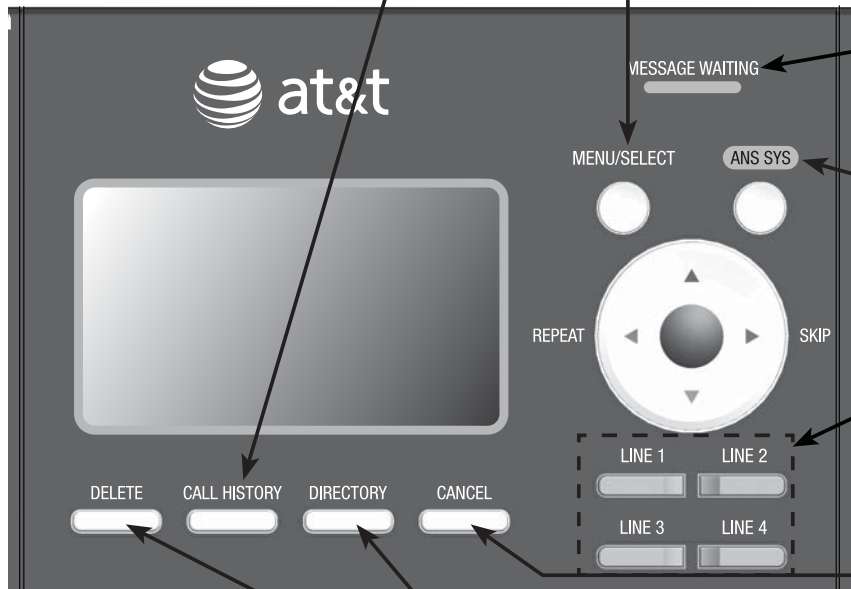

MENU/SELECT

Press to enter the menu. While in the menu, press to select an item or save an entry or setting.

MESSAGE WAITING indicator

On when there are new or missed calls (page 64).

ANS SYS keys

Press to show the automatic answer options for that line (page 62).

LINE 1-LINE 4 keys

Press to make or answer a call on the desired line (pages 36-37).

DELETE

While playing a message, press to delete the message ().

While reviewing the caller ID information, press to delete an individual entry (page 56).

While predialing, press to delete digits (page 36).

CANCEL

While in a menu, press to cancel an operation and exit the menu display.

DIRECTORY

Press to view directory information (52).

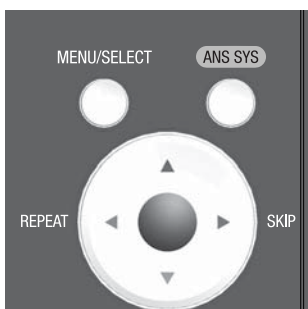

Navigation keys

While in menus, press ▲ or ▼ to scroll through the menus, highlight items or change settings. Press ◀REPEAT to return to the previous menu.

While entering names or numbers, press ◀REPEAT or SKIP▶ to move the cursor to the left or right.

While playing back messages, press ◀REPEAT once to repeat the message, or press ◀REPEAT twice to hear the previous message, or press SKIP▶ to skip to the next message.

Quick reference guide

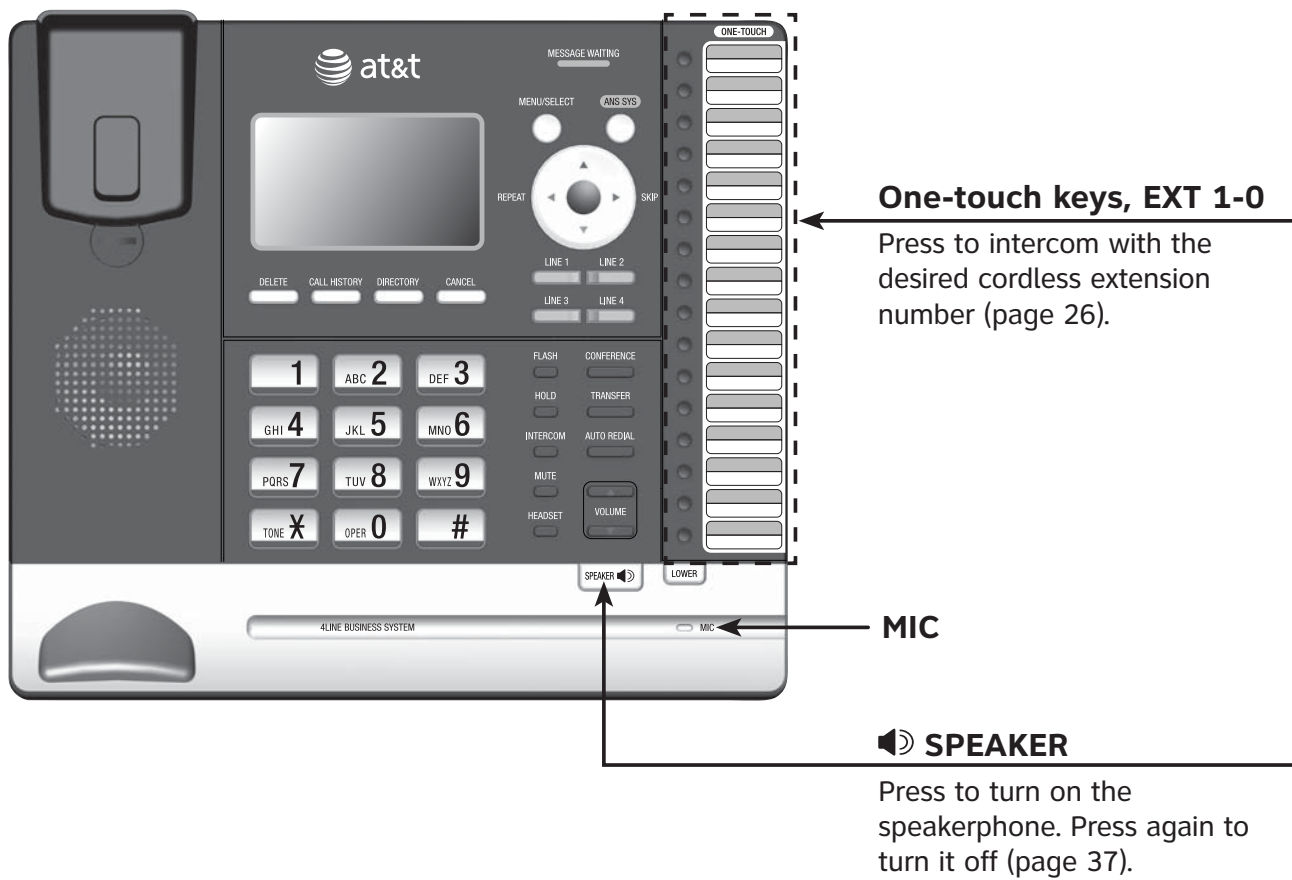

Directory card

To write names on the directory card, follow the steps below:

1. Pull out the directory card.
2. Write the information on the directory card.
3. Replace the directory card and the plastic cover.

Quick reference guide

FLASH

During a call, press to answer an incoming call when you receive a call waiting alert (page 40).

HOLD

Press to place an outside call on hold (page 42).

INTERCOM

When in idle mode, press to initiate an intercom call (page 47).

MUTE

During a call, press to mute the microphone (page 41). During an incoming call, press to mute the ringer (page 37).

HEADSET

When a corded headset is connected to the telephone base, press to get a line, answer a call or hang up (page 36). The red indicator is on when the headset is in use.

Main menu

The > symbol highlights a menu item.

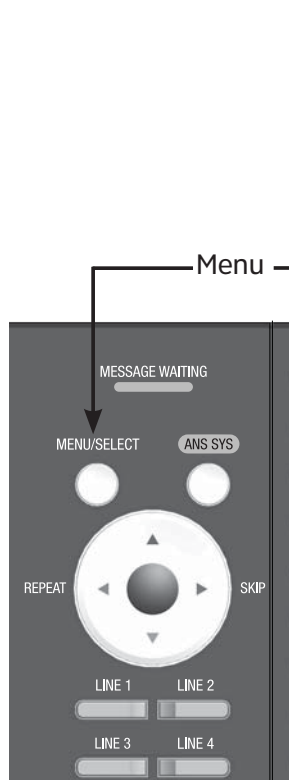

Main menu

- System Setup
- Ringers
- Set Date/Time
- One Touch
- Phone Settings
- Registration
- Customer Support

Using menus

- Press **MENU/SELECT** to show the first menu item, **System Setup**.
- Press **▲** or **▼** to scroll through menu items.
- Press **MENU/SELECT** to select or save changes to a highlighted menu item.
- Press **CANCEL** to cancel an operation, exit the menu display or return to the idle screen.
- Press **◀/REPEAT** to back up to the previous menu.

CONF

Press to add another extension or outside line to an existing call (page 45).

TRANSFER

Press to transfer a call to an extension (page 48).

AUTO REDIAL

Press repeatedly to view the last 10 numbers dialed (page 39). Press to redial a number up to ten times (page 39).

▲/VOLUME/▼

During a call, press to adjust the listening volume (page 40). During message playback, press to adjust the playback volume (page 64).

LOWER

When assigning an One-touch key, press to store the number to the desired location..

Introduction

This AT&T MS2015 telephone is not a standalone system. You must purchase the MS2085 Console and register this telephone with the Console before use. You can also register a MS2025 cordless handset to this telephone.

The MS2015 telephone is hearing-aid compatible and can be connected to four incoming telephone lines. This telephone features a speakerphone for handsfree use and a headset jack compatible with most two-band 2.5mm headsets (sold separately).

There are two additional ports, known as the LAN port and PC port. The Ethernet port allows the MS2015 telephone to connect with the MS2085 Console via a router. The PC port is for connecting the telephone to another device such as a personal computer.

The MS2015 console enables paging, intercom, and call transfers between system extensions and is capable of connecting three parties (two external lines and a system extension) in the same conference call.

This telephone also features a 32-number one- and two-touch memory for faster dialing and has a directory that can store up to 50 additional numbers with names. This telephone has a caller ID feature that supports caller ID with call waiting service. Caller ID services are subscriber services available from many telephone service provider for a fee. The telephone can store up to 200 caller ID entries.

Your MS2015 telephone also features a built-in digital answering system with a private mailbox each that can store approximately 60 minutes of messages, memos and conversations or a total of up to 99 messages. You can access the answering system from a remote non-system touch-tone telephone or from another system telephone. This user's manual contains detailed instructions for using your AT&T Small Business System MS2015 telephone. Please read this user's manual before using this telephone.

Planning your system

The MS2015 package includes only the telephone deskset. You have to purchase MS2085 main console and/or MS2025 cordless handset separately to expand your system. To order them, visit our website at **www.telephones.att.com** or call **1 (800) 222-3111**. In Canada, dial **1 (866) 288-4268**. The MS2015 telephone can accommodate a cordless handset.

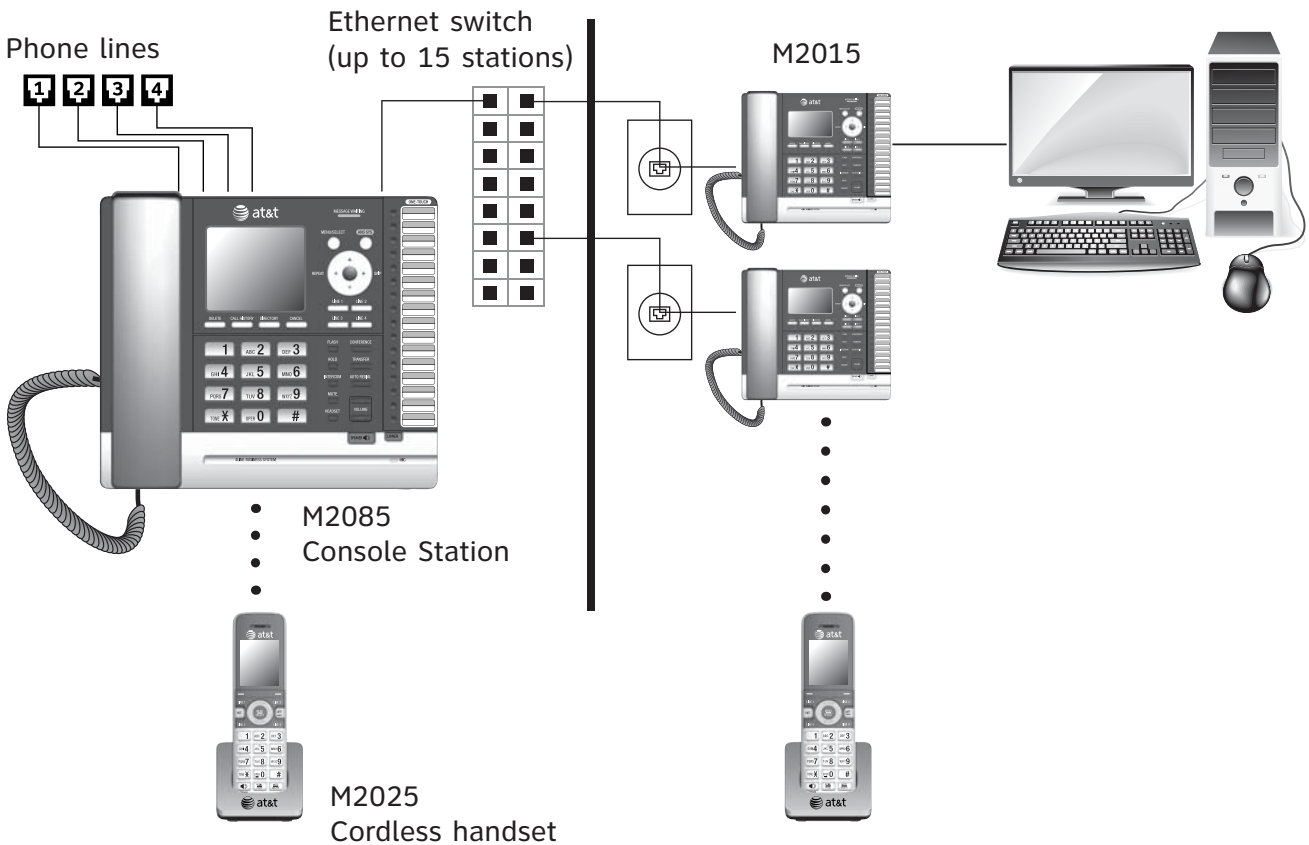

NOTES:

- You must have modular telephone jacks and an electrical outlet not controlled by a wall switch near where you are installing the phone.
- Assign a different system extension number EXT XX to each system telephone (see the **EXTENSION NUMBER** section on page XX). We recommend assigning EXT 11 to an auto-attendant telephone. Every individual phone in your telephone system **MUST** be assigned a unique extension number for the intercom feature to work.

Installation

Install the deskset close to a router and a power outlet not controlled by a wall switch. The telephone can be placed on a flat surface or vertically mounted on the wall. For optimum range and better reception, place the deskset in a central and open location.

If you subscribe to high-speed Internet service (DSL - digital subscriber line) through your telephone lines, you must install a DSL filter between each telephone line cord and telephone wall jack (page 7). The filter prevents noise and caller ID problems caused by DSL interference. Please contact your DSL service provider for more information about DSL filters.

Your product may be shipped with a protective sticker covering the deskset and handset displays - remove them before use.

For customer service or product information, visit our website at **www.telephones.att.com** or call **1 (800) 222-3111**. In Canada, dial **1 (866) 288-4268**.

Avoid placing the deskset too close to:

- Communication devices such as television sets, VCRs, or other cordless telephones.
- Excessive heat sources.
- Noise sources such as a window with traffic outside, motors, microwave ovens, refrigerators, or fluorescent lighting.
- Excessive dust sources such as a workshop or garage.
- Excessive moisture.
- Extremely low temperature.
- Mechanical vibration or shock such as on top of the washing machine or work bench.

Table/desktop installation

1. Plug the end of the coiled handset cord into the **HANDSET** jack on the left side of the telephone.



2. Lift the kickstand as the arrow indicated below to detach it from the deskset. There are seven grooves designed to hold the deskset in different angles for maximum visibility. Snap the kickstand into the desired groove until it locks into place.

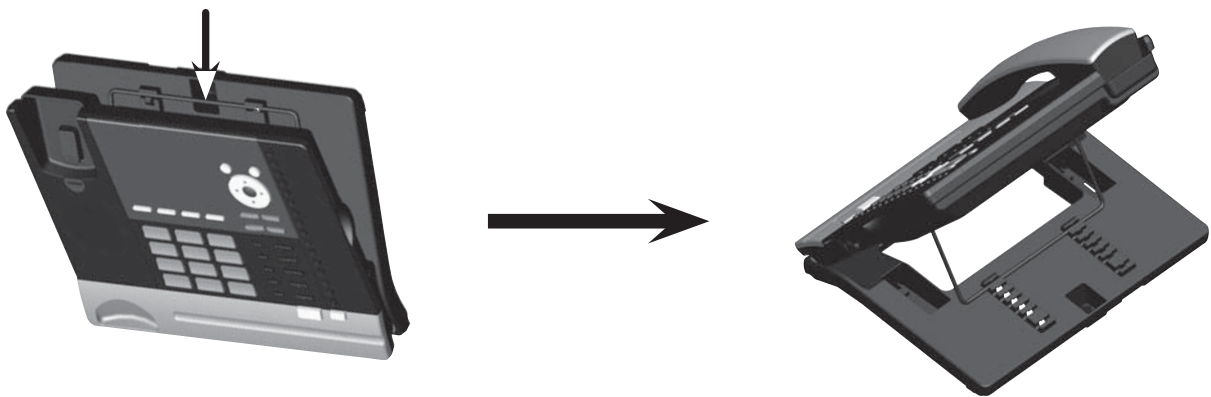

3. Install the Ethernet cable and power adapter as shown below.

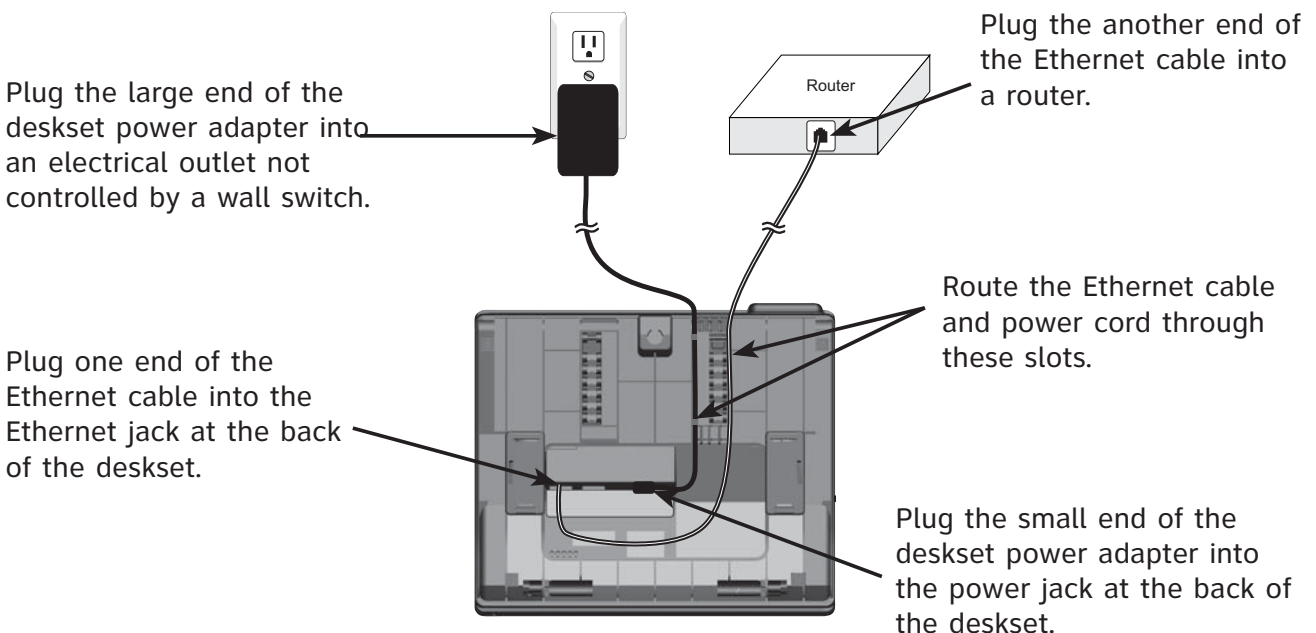

IMPORTANT INFORMATION

1. Use only the power adapter supplied with this product. To order a replacement power adapter, visit our website at www.telephones.att.com, or call **1 (800) 222-3111**. In Canada, dial **1 (866) 288-4268**.
2. The power adapter is intended to be correctly oriented in a vertical or floor mount position. The prongs are not designed to hold the plug in place if it is plugged into a ceiling, under-the-table or cabinet outlet.

Wall mount installation

To mount the deskset on the wall

1. Unplug the power adapter from the power outlet. Unplug the Ethernet cable from the router.
2. Put the corded handset aside. Use a coin to rotate the handset tab 180 degrees. The protruding edge holds the corded handset when the phone is mounted on the wall.

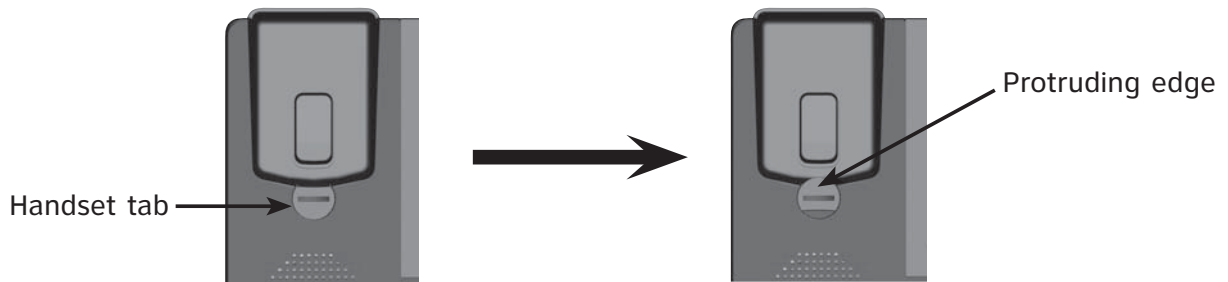

2. Lift the kickstand to detach it from the deskset, then snap it into the outermost groove until it locks into place.

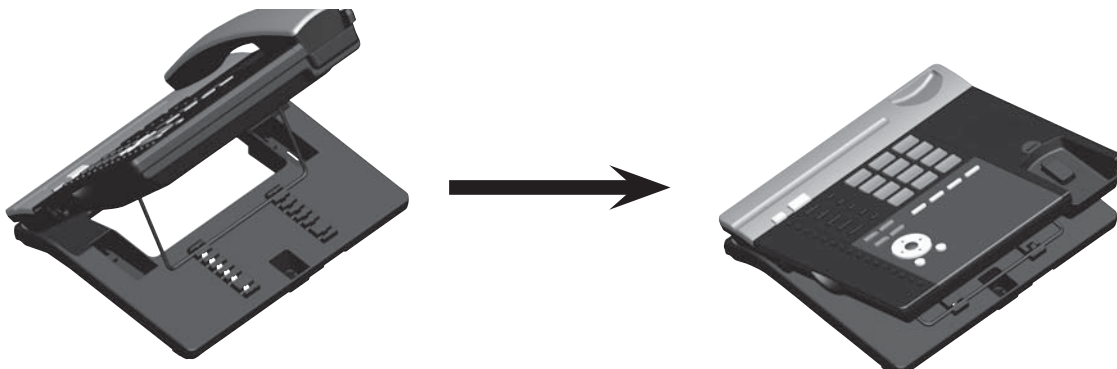

3. Install the wall mount bracket to the deskset as shown below. Insert the upper tabs of the mounting bracket into the upper slots of the deskset. Press the lower tabs of the mounting bracket into the lower slots of the deskset until they lock into place.

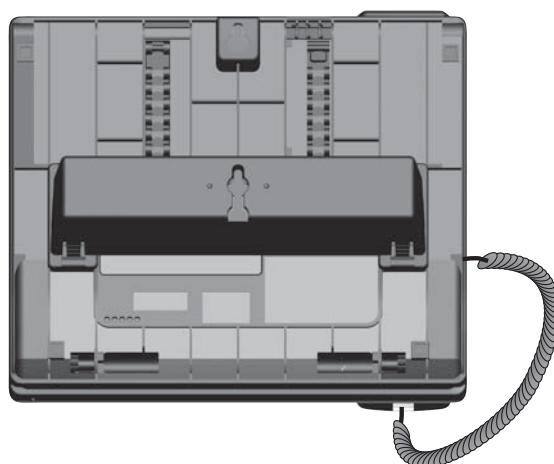

Wall mount installation

4. Plug the Ethernet cable into the router and the power adapter into an electrical outlet not controlled by a wall switch.

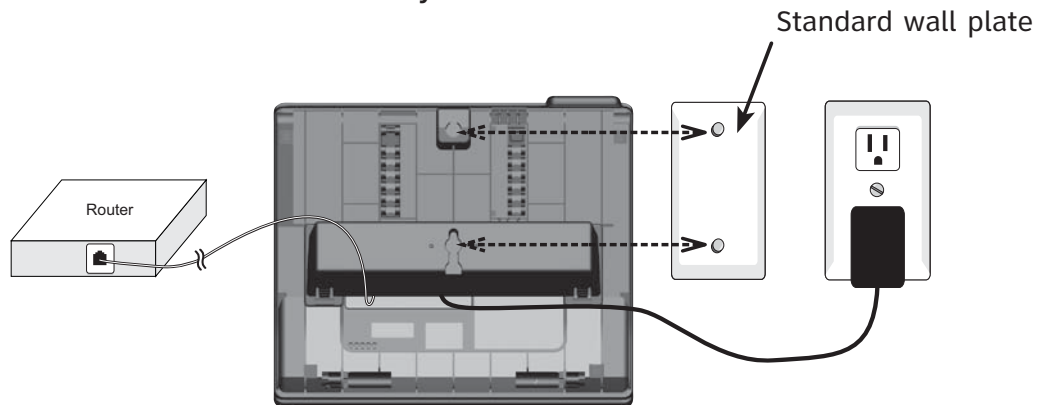

5. Align the upper wall mounting hole on the back of the deskset with the upper tab of the standard wall plate. Make sure the lower wall mounting hole on the mounting bracket also aligns with the lower tab of the standard wall plate. Push the deskset down until it clicks securely in place.
6. Bundle the Ethernet cable and power adapter cord neatly with twist ties.

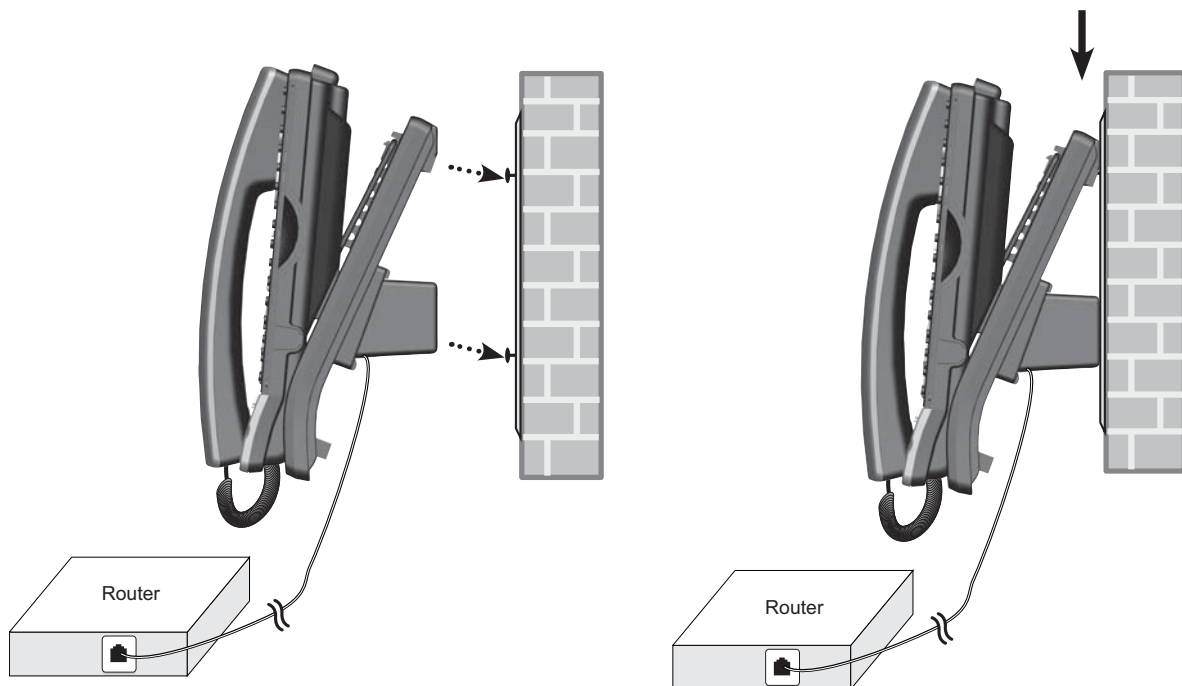

Wall mount installation

Wall mount to tabletop installation

To change the deskset from the wall mount position to tabletop position, follow the steps below.

1. If the Ethernet cable and power adapter cord are bundled, untie them first.
2. Push the deskset up to remove it from wall. Unplug the Ethernet cable from the router. Unplug the power adapter from the power outlet.
3. See **Table/desktop installation** on page 7.

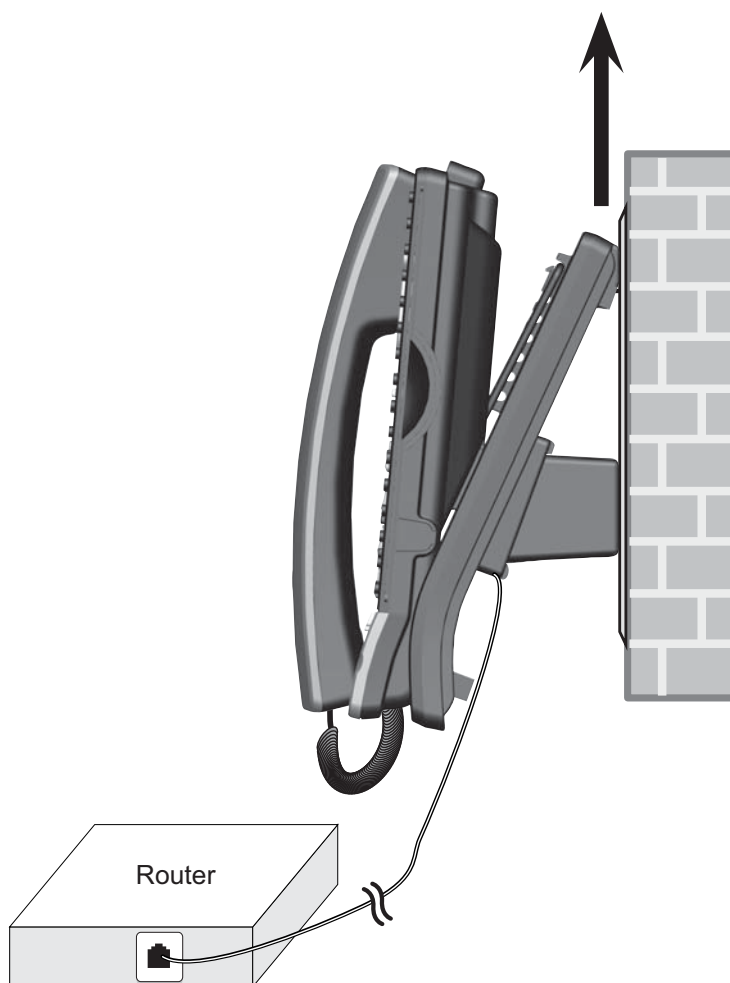

Adding and registering desksets

The desksets must be registered to the main console before use. You must register each deskset separately.

Make sure your deskset is installed properly. Start registration when the deskset screen shows **IP obtained: XXX.XXX.X.X Press SELECT to proceed**.

To register a deskset to your MS2085 main console

1. The deskset shows **IP obtained: XXX.XXX.X.X Press SELECT to proceed**. before you begin registration.
2. On the main console, press **MENU/SELECT**.
3. The screen displays **Enter the name of the Console that this phone is connected to**. Then the screen displays **Console's name:**
4. Use the dialing key on the deskset to enter the name of Console.
 - Press **DELETE** to delete a character.
 - Press and hold **DELETE** to delete all characters.
 - Press **◀/REPEAT** or **▶/SKIP** to move the cursor left or right.
5. Press **MENU/SELECT** to save. The screen displays **Connecting to Console X...** (**Console X** represents the deskset name).
6. It takes up to 60 seconds to complete the registration. You hear a confirmation tone when the registration is successful. The deskset shows **Deskset is connected to Console X** and the deskset shows **Deskset X (Deskset X** represents the deskset name).
7. Press any key on the deskset to confirm. The deskset screen displays **Please set and extension number to this phone**.
8. Press **◀/REPEAT** or **▶/SKIP** to choose the desired extension number. The extension ranges from **11** to **26**.
9. Press **MENU/SELECT** to confirm. You hear a confirmation tone.

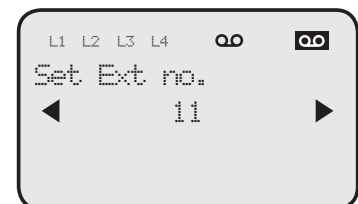
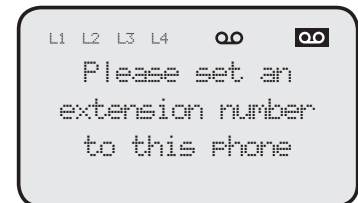
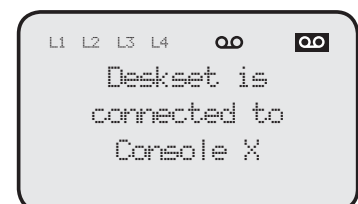
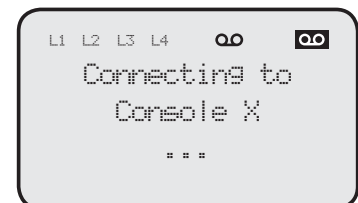
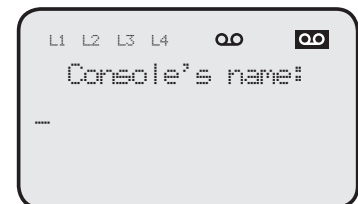
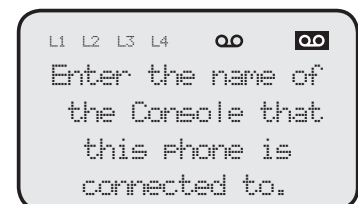
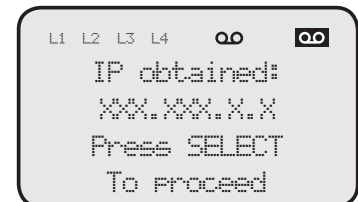

NOTE: If the registration is not successful, the deskset screen displays **Deskset cannot connect to Console X** with an error tone, the deskset screen displays **Check Console** in idle screen. Try the registration process again.

Adding and registering a cordless handset

You can add a new cordless handset (**MS2025**, purchased separately) to your telephone system, but it must be registered with the MS2015 deskset before use. When first purchased, the expansion handset shows **Choose Handset in Registration at base menu. And put handset on cradle to register.**

If the handset does not have enough power to proceed with the registration, you need to charge the new handset for at least five minutes (see **Battery installation and charging** in the cordless handset manual). Start registration when the handset screen shows **Choose Handset in Registration at base menu. And put handset on cradle to register.**

To register a cordless handset to your MS2015 deskset

1. Make sure the cordless handset is out of the charger and the screen shows **Choose Handset in Registration at base menu. And put handset on cradle to register.**
2. On the MS2015 deskset, press **MENU/SELECT.**
3. Scroll down to **Registration** and press **MENU/SELECT.**
4. Press **MENU/SELECT** again to select **Handset.** The deskset screen shows **Registering handset... (Put handset on cradle to start).**
5. Place the unregistered cordless handset into the charger. The handset beeps once and begins registering to the MS2015 deskset. It takes up to 60 seconds to complete the registration. There is a beep sound when the registration is successful. The MS2015 deskset shows **Handset registered** and then the handset shows **Handset X** (**Handset X** represents the handset name).

NOTES:

1. If the registration is not successful, the MS2015 main console screen displays **Registration failed** with an error tone. To reset the handset, remove the handset from the cradle. Try the registration process again.
2. Make sure to remove all unregistered system handsets or cordless headset from the cradles before registering a new handset.

Adding and registering a cordless headset

You can use this phone handsfree when you register a DECT 6.0 cordless headset to the MS2015 deskset. You can only register one cordless headset to the MS2015 deskset. The cordless headset must have a charged battery. Make sure the headset battery is properly installed.

The telephone system is compatible with certain AT&T DECT 6.0 cordless headsets. Visit **www.telephones.att.com/headsets** for a list of compatible cordless headsets.

To register a cordless headset to your MS2015 deskset

1. Place the headset in the headset charger and allow it to charge for at least five minutes before beginning registration. Make sure the headset is out of the headset charger before you begin registration.
2. On the MS2015 deskset, press **MENU/SELECT**.
3. Scroll down to **Registration** and press **MENU/SELECT**.
4. Set your headset to discoverable mode, refer to the user's manual of your headset for instructions.
5. Press **▲** or **▼** to scroll to **DECT Headset** then press **MENU/SELECT**. The MS2015 deskset shows **Registering DECT Headset...** It takes up to 60 seconds to complete the registration.
6. The MS2015 deskset shows **DECT Headset registered** and you hear a confirmation tone when the registration is successful.

Refer to the user's manual of your cordless headset for more details on registration. For a list of compatible DECT 6.0 cordless headset, visit www.telephones.att.com/headsets.

Deregistering cordless handset or cordless headset

You may need to deregister your cordless handset or headset when you have a registered handset or headset and need to replace one. **Please read all the instructions on this page before beginning the deregistration process.**

Please make sure the telephone system is not in use before deregistration.

To deregister the cordless handset or headset from the MS2015 deskset

1. On the deskset, press **MENU/SELECT**.
2. Scroll down to **Registration** and press **MENU/SELECT**.
3. Scroll down to **Deregistration** and press **MENU/SELECT**.
4. Press **MENU/SELECT**.
5. Press **MENU/SELECT** to choose **Handset**.

-OR-

Press **▲** or **▼** to choose **DECT Headset**.

6. The deskset screen shows **Deregister Handset? Press <SELECT> to confirm** if you selected **HANDSET**, or **Deregister DECT Headset? Press <SELECT> to confirm** if you selected **DECT Headset**. Press **MENU/SELECT** to confirm.
7. The deskset shows **Deregistering**. It takes up to 10 seconds to complete the deregistration.
 - If you are deregistering the cordless handset, the deskset shows **Handset deregistered** and a confirmation tone when the deregistration is successful.
 - If you are deregistering the DECT headset, the deskset shows **DECT Headset deregistered** and a confirmation tone when the deregistration is successful.



NOTES:

1. If the deregistration process is not successful, you might need to reset the system and try again. To reset, you can press **CANCEL** on the deskset. You can also reset the deskset by unplugging the power from the deskset and plugging it back in.
2. To register a cordless handset again, refer to the registration information on page 12.
3. To register a cordless headset again, refer to the registration information on page 13.

Adding a corded headset

You can use this telephone handsfree when you install any industry-standard 2.5mm corded telephone headset (purchased separately). For best results, use an AT&T 2.5mm corded headset. To purchase a headset, visit our website at www.telephones.att.com, or call **1 (800) 222-3111**. In Canada, dial **1 (866) 288-4268**.

To add a corded headset to the deskset

Plug a 2.5 mm headset into the **HEADSET** jack on the side of the deskset.



Side view of the deskset



NOTE: If you have corded and cordless headsets connected to your deskset, the **HEADSET** button only controls the corded headset.

System setup

Menu settings

Use this menu to change the telephone system settings.

1. Press **MENU/SELECT** when in idle mode (when the telephone is not in use) to enter the main menu.
2. Press ▲ or ▼ to scroll to the feature to be changed.
The > symbol indicates the selected menu item.
3. Press **MENU/SELECT** to select the menu item.
4. Press **CANCEL** to exit setup without making changes.



NOTE: Press **CANCEL** to cancel an operation, exit the menu display, or return to idle mode.

System setup

Set extension number

Each individual phone in the telephone system **MUST** be assigned a unique extension number for the intercom feature to work. The assignment is done automatically when the phone is initially setup.

To change the extension number:

1. When the telephone is idle, press **MENU/SELECT**.
2. Press **MENU/SELECT** to choose **System Setup**.
3. Press **▲** or **▼** to scroll to **Set Ext. No.** then press **MENU/SELECT**.
4. The screen displays **Set Ext No.** Press **◀/REPEAT** or **▶/SKIP** to choose the desired extension number (**11-26**).
5. Press **MENU/SELECT** to save the setting and return to the previous menu. There is a confirmation tone. To exit without making changes, press **CANCEL**.



NOTES:

1. If the extension number is already being used, the screen displays **Extension number already in use** briefly and you hear an error tone.
2. If you want to assign an extension number that is already being used, see MS2085 main console user's manual to replace the number.

System setup

Prime line

Use this feature, also known as automatic line selection, to choose which line is automatically selected each time you lift the handset, press **SPEAKER**  or **HEADSET** (if a headset is connected) to make an outside call.

To set the prime line:

1. When the telephone is idle, press **MENU/SELECT**.
2. Press **MENU/SELECT** to choose **System Setup**.
3. Press **▲** or **▼** to scroll to **Prime Line** then press **MENU/SELECT**.
4. Press **▲** or **▼** to choose the desired line and then press **MENU/SELECT**.



NOTE: If you choose the line that is not connected to the telephone wall jack, the console main console displays **No line connects to Line X. But settings will still be saved.** and you hear a notification tone.

System setup

Network setup

The deskset must have an IP address locating its connection with the router/SIP server. You can set the deskset to obtain IP from a DHCP server or assign a specific IP on your own.

To enable the Auto set IP:

1. When the telephone is idle, press **MENU/SELECT**.
2. Press **MENU/SELECT** to choose **System Setup**.
3. Press **▲** or **▼** to scroll to **Network Setup** then press **MENU/SELECT**.
4. Press **▲** or **▼** to scroll to **Auto set IP** then press **MENU/SELECT**.
5. Press **▲** or **▼** to scroll to **Yes** then press **MENU/SELECT**.
6. The screen displays **Obtain IP from DHCP server?** Press **MENU/SELECT** to save the setting. There is a confirmation tone.
7. The screen displays **Obtaining IP from DHCP server Please wait...** The process takes up to one minute.
8. There is a confirmation tone when the IP is successfully assigned. The screen displays **IP obtained: XXX.XXX.X.X Check network info?** Press **MENU/SELECT** to read the network info, or press **CANCEL** to return to the main menu.
 - If the IP did not successfully retrieved, the screen displays **Unable to obtain IP. Please check DHCP server.** briefly, and then **Set static IP to this extension?** You may press **MENU/SELECT** to enter the Static IP setting.

System setup

If you want to switch from Auto set IP to Set static IP, you have to change disable the auto IP setting first.

To disable the Auto set IP:

1. When the telephone is idle, press **MENU/SELECT**.
2. Press **MENU/SELECT** to choose **System Setup**.
3. Press **▲** or **▼** to scroll to **Network Setup**. Press **MENU/SELECT**.
4. Press **▲** or **▼** to scroll to **Auto set IP**. Then press **MENU/SELECT**.
5. Press **▲** or **▼** to scroll to **No**. Press **MENU/SELECT**. The main console

To enable the Static IP:

1. When the telephone is idle, press **MENU/SELECT**.
2. Press **MENU/SELECT** to choose **System Setup**.
3. Press **▲** or **▼** to scroll to **Network Setup**. Press **MENU/SELECT**.
4. Press **▲** or **▼** to scroll to **Static IP**. Then press **MENU/SELECT**.
5. The screen displays **Enter static IP**.
6. Use the dialing keys to enter a specific IP.
 - Press **DELETE** to delete a character.
 - Press and hold **DELETE** to delete all characters.
 - Press **◀/REPEAT** or **▶/SKIP** to choose **Add dot**, then press **MENU/SELECT** to add a dot.

Press **◀/REPEAT** or **▶/SKIP** to choose **Done**, then press **MENU/SELECT**.

7. There is a confirmation tone when a valid IP is entered. The screen displays **IP obtained: XXX.XXX.X.X Check network info?** Press **MENU/SELECT** to read the network info, or press **CANCEL** to return to the main menu.
 - If the IP entered is invalid, the screen displays **IP is invalid**. briefly and then returns to the **Enter static IP** screen.

System setup

Network info

Use this feature to view the information of IP address, subnet mask, router/gateway, DNS servers, DHCP server of the telephone system.

To check the network information:

1. When the telephone is idle, press **MENU/SELECT**.
2. Press **MENU/SELECT** to choose **System Setup**.
3. Press ▲ or ▼ to scroll to **Network Info**. Press **MENU/SELECT**.
4. Press ▲ or ▼ to browse through the network information.

Telephone setup

Ringer volume

Use this feature to set the ringer volume to one of six levels or turn the ringer off. When the ringer is off, the  icon appears on the deskset screen. The MS2015 deskset stores the volume setting for all lines.

1. When the telephone is idle, press **MENU/SELECT**.
2. Press **▲** or **▼** to scroll to **Ringers** then press **MENU/SELECT**.
3. Press **MENU/SELECT** again to select **Ringer volume**.
4. Press **▲**, **▼**, **◀**, **▶**, or **▲VOLUME▼** on the deskset to adjust the ringer volume.
5. Press **MENU/SELECT** to save the setting and return to the previous menu. There is a confirmation tone. To exit without making changes, press **CANCEL**.



NOTE: The ringer volume also determines the ringer volume for intercom calls (page 47). If the deskset ringer volume is set to off, that deskset is silenced for all incoming calls, including intercom calls.

Telephone setup

Ringer tone

Use this feature to choose one of the seven ringer tones for incoming calls. You can choose different ringer tones for different lines so you can easily identify which line is calling.

1. When the telephone is idle, press **MENU/SELECT**.
2. Press ▲ or ▼ to scroll to **Ringers** then press **MENU/SELECT**.
3. Press ▲ or ▼ to scroll to **Ringer tone** then press **MENU/SELECT**.
4. Press ◀/REPEAT or ▶/SKIP to select the desired line (**Line 1**, **Line 2**, **Line 3** or **Line 4**).
5. Press ▲ or ▼ to select a desired ringer tone.
6. Repeat steps 4-5 above to choose ringer tones for other lines if desired.
7. Press **MENU/SELECT** to save the setting and return to the previous menu. There is a confirmation tone. To exit without making changes, press **CANCEL**.



NOTE: If you turn off the ringer volume, you will not hear ringer tone samples.

Telephone setup

Delay ring

Use this feature to set the length of time before an incoming call will ring.

1. When the telephone is idle, press **MENU/SELECT**.
2. Press ▲ or ▼ to scroll to **Ringers** then press **MENU/SELECT**.
3. Press ▲ or ▼ to scroll to **Delay ring** then press **MENU/SELECT**.
4. Press **REPEAT**◀ or **SKIP**▶ to select a desired line (**Line 1**, **Line 2**, **Line 3** or **Line 4**).
5. Press ▲ or ▼ to scroll to the desired time (**2 seconds** to **30 seconds**).
6. Press **MENU/SELECT** to save the setting and return to the previous menu. There is a confirmation tone. To exit without making changes, press **CANCEL**.

Telephone setup

Set Date/Time

The answering system displays the date and time of the message while playing messages. Before using the answering system, set the date and time as follows. If you subscribe to caller ID service, the day, month and time are set automatically with each incoming call. The year must be set so that the day of the week can be calculated from the caller ID information.

Follow the steps below to set the month, day, year and time:

1. When the telephone is idle, press **MENU/SELECT**.
2. Press ▲ or ▼ to scroll to **Set Date/Time** then press **MENU/SELECT**.
3. Press ▲ or ▼ to scroll to **Date and time** then press **MENU/SELECT**.
4. Use the dialing keys to enter the day, month and year.
5. Press **MENU/SELECT** to move to the time editing.
6. Use the dialing keys to enter the hour and minute.
7. Press ◀/REPEAT or ▶/SKIP to select **AM** or **PM**, or press **2** for **AM** or **7** for **PM**.
8. Press **MENU/SELECT** to save the setting and return to the previous menu. There is a confirmation tone. To exit without making changes, press **CANCEL**.



NOTES:

1. The time is in a 12-hour format. If you set an invalid time, you will hear an error tone after pressing **MENU/SELECT** to save the setting.
2. If the date and time are not set when a message is recorded, the system does not display date and time on the screen while playing messages.

Telephone setup

One Touch

This telephone has 32 one-touch locations (speed dial locations) where you can store the phone numbers you wish to dial using fewer keys than usual. You can store up to 24 digits in each location.

You can access the first 16 locations using only the one-touch buttons. To access the remaining 16 locations, press **LOWER** and then the one-touch button for the desired location. You might wish to write the names or telephone numbers of the one-touch entries on the directory card, using the light gray spaces for the first 16 locations and the white spaces for the second 16 locations.

Assign a one-touch entry

Use the following steps to program the one-touch keys.

1. When the telephone is idle, press **MENU/SELECT**.
2. Press ▲ or ▼ to scroll to **One Touch** then press **MENU/SELECT**.
3. Press ▲ or ▼ to scroll to **Program** then press **MENU/SELECT**.
4. The screen displays **Enter Number**.
5. Use the dialing keys to enter a telephone number (up to 24 digits).
 - Press **DELETE** to delete a digit.
 - Press and hold **DELETE** to delete all digits.
 - Press ◀/**REPEAT** or ▶/**SKIP** to move the cursor to the left or right.
 - You can include a pause while storing a dialing sequence that requires one during actual dialing. Press ▲ or ▼ to choose ♦**Add Pause**, then press **MENU/SELECT**. A **P** appears on the screen.
 - **Store a signal for switching to temporary tone signalling.** If you have dial pause (rotary) service, this signal is required for some special services. Press ▲ or ▼ to choose ♦**Add Tone**, then press **MENU/SELECT**. A **T** appears on the screen. All numbers you enter after this will send touch-tone signals during dialing.
 - You can store the flash signal required by some special services as part of a dialing sequence. Press ▲ or ▼ to choose ♦**Add Flash**, then press **MENU/SELECT**. A **F** appears on the screen. Continue storing the number as usual.
6. Press ▲ or ▼ to choose ♦**Done** then press **MENU/SELECT** to save the setting and return to the previous menu. There is a confirmation tone. To exit without making changes, press ▲ or ▼ to choose ♦**CANCEL** then press **MENU/SELECT**, or press **CANCEL** to previous menu. Assign a one-touch entry (continued)

Telephone setup

7. The screen displays **Press a 1-touch key to save the number.**
8. Press the desired one-touch key to store a the telephone number in the upper location.

-OR-

Press **LOWER**, then press the desired one-touch key to store the telephone number in the lower location.

9. Press ▲ or ▼ to choose **Done**, then press **MENU/SELECT** to save the setting.
- 10The screen displays **Number saved to 1-touch key** briefly, and then **One Touch #XX** (X represents the one-touch location) and the telephone number.



NOTE: If the one-touch location already has an assigned number, the screen displays **Replace 1-touch key memory?** Press **MENU/SELECT** to replace the old number with the new one.

Telephone setup

Review the one-touch entry

1. When the telephone is idle, press **MENU/SELECT**.
2. Press ▲ or ▼ to scroll to **One Touch** then press **MENU/SELECT**.
3. Press ▲ or ▼ to scroll to **View** then press **MENU/SELECT**.
4. Press ▲ or ▼ to scroll to the desired one-touch location. The screen displays the One-touch location number, the telephone number.

To dial a one-touch entry

1. When the telephone is idle, press the one-touch button for the destination party in the upper location.

-OR-

When the telephone is idle, press **LOWER**, then press the one-touch button for the destination party in the lower location.

2. Lift the handset or press **SPEAKER** to dial the call.

Edit the one-touch key

1. When the telephone is idle, press **MENU/SELECT**.
2. Press ▲ or ▼ to scroll to **One Touch**. then press **MENU/SELECT**.
3. Press ▲ or ▼ to scroll to **View** then press **MENU/SELECT**.
4. Press ▲ or ▼ to scroll to the desired one-touch location.
5. Press ◀/REPEAT or ▶/SKIP to scroll to **Edit**, then press **MENU/SELECT**.
6. The screen displays **Edit Number**. Use the dialing keys to edit the number.
 - Press **DELETE** to delete a digit.
 - Press and hold **DELETE** to delete all digits.
 - Press ◀/REPEAT or ▶/SKIP to move the cursor to the left or right.
 - You can include a pause while storing a dialing sequence that requires one during actual dialing. Press ▲ or ▼ to choose **◆Add Tone**, then press **MENU/SELECT**. A **P** appears on the screen.
 - **Store a signal for switching to temporary tone signalling.** If you have dial pause (rotary) service, this signal is required for some special services. Press ▲ or ▼ to choose **◆Add Tone**, then press **MENU/SELECT**. A **T** appears on the screen. All numbers you enter after this will send touch-tone signals during dialing.

Telephone setup

Edit the one-touch key (continued)

- Store a signal for switch to temporary tone dialing. Press ▲ or ▼ to choose **◆Add Tone**, then press **MENU/SELECT**. A **T** appears on the screen. All numbers you enter after this will send touch-tone signals during dialing.
 - You can store the flash signal required by some special services as part of a dialing sequence. Press ▲ or ▼ to choose **◆Add Flash**, then press **MENU/SELECT**. A **F** appears on the screen. Continue storing the number as usual.
7. Press **◀/REPEAT** or **▶/SKIP** to scroll to **◆Done** then press **MENU/SELECT** to save the setting and return to the previous menu. There is a confirmation tone.

Delete an one-touch key

1. When the telephone is idle, press **MENU/SELECT**.
2. Press ▲ or ▼ to scroll to **One Touch** then press **MENU/SELECT**.
3. Press ▲ or ▼ to scroll to **View** then press **MENU/SELECT**.
4. Press ▲ or ▼ to scroll to the desired one-touch location.
5. Press **◀/REPEAT** or **▶/SKIP** to scroll to **Delete**, then press **Delete memory?**
6. Press **MENU/SELECT** to confirm. There is a confirmation tone. To exit without making changes, press **CANCEL**.

Telephone setup

LCD Language

This feature allows you to change the language used for all screen displays. The language settings on the main console and desksets are independent. By default, the language is set to **English**.

1. When the telephone is idle, press **MENU/SELECT**.
2. Press ▲ or ▼ to scroll to **Phone Settings** then press **MENU/SELECT**.
3. Press ▲ or ▼ to scroll to **LCD Language** then press **MENU/SELECT**.
4. Press ▲ or ▼ to select **English, Français** or **Español**.
5. Press **MENU/SELECT** again to save the setting and return to the previous menu. There is a confirmation tone. To exit without making changes, press **CANCEL**.

Telephone setup

Area codes

Use this feature to program this system to recognize one home area code and up to four local area codes. This feature makes it easy for you to place a call from the caller ID log.

If you dial seven digits to make a local call (no area code required), enter your area code into the telephone as the home area code. When you receive a call from within your home area code, the caller ID information only displays the seven digits of the telephone number, and when you dial from the call log, only seven digits are dialed.

If you must dial 10 digits (the area code and telephone number) for local calls, enter **000** for the home area code and enter your area code as a local area code. Then, if you receive a call from within your area code, the screen displays all 10 digits of the telephone number, and when you dial from the call log, all 10 digits are dialed.

If you have more than one area code for your region, enter those area codes as local area codes.

1. When the telephone is idle, press **MENU/SELECT**.
2. Press **▲** or **▼** to scroll to **Phone Settings** then press **MENU/SELECT**.
3. Press **▲** or **▼** to scroll to **Area Codes** then press **MENU/SELECT**.
4. Press **▲** or **▼** to scroll to **Home area code** or **Local area code 1 - Local area code 5**. Press **MENU/SELECT** to edit it.
5. Use the dial pad keys to enter a three-digit area code.
 - Press **DELETE** to delete a digit.
 - Press and hold **DELETE** to delete all digits.
6. Press **MENU/SELECT** to save the setting and return to the previous menu. There is a confirmation tone. To exit without making changes, press **CANCEL**.

Telephone setup

Key Tone

The deskset is set to beep with each key press. If you turn off the key tone, there are no beeps when you press keys.

1. When the telephone is idle, press **MENU/SELECT**.
2. Press ▲ or ▼ to scroll to **Phone Settings** then press **MENU/SELECT**.
3. Press ▲ or ▼ to scroll to **Key Tone** then press **MENU/SELECT**.
4. Press ▲ or ▼ to choose **On** or **Off**.
5. Press **MENU/SELECT** to save the setting and return to the previous menu.
There is a confirmation tone. To exit without making changes, press **CANCEL**.

LCD contrast

Use this feature to adjust the screen contrast to one of eight levels to optimize readability in different lighting conditions.

1. When the telephone is idle, press **MENU/SELECT**.
2. Press ▲ or ▼ to scroll to **Phone Settings** then press **MENU/SELECT**.
3. Press ▲ or ▼ to scroll to **LCD Contrast** then press **MENU/SELECT**.
4. Press ▲ or ▼ to choose the desired screen contrast level (**Level 1 - Level 8**).
5. Press **MENU/SELECT** to save the setting and return to the previous menu.
There is a confirmation tone. To exit without making changes, press **CANCEL**.

Telephone setup

Dial mode

The dial mode is preset to tone dialing. If you have pulse (rotary) service, you must change the dial mode to pulse dialing before using the telephone.

1. When the telephone is idle, press **MENU/SELECT**.
2. Press ▲ or ▼ to scroll to **Phone Settings** then press **MENU/SELECT**.
3. Press ▲ or ▼ to scroll to **Tone/Pulse** then press **MENU/SELECT**.
4. Press ▲ or ▼ to choose **Tone** or **Pulse**.
5. Press **MENU/SELECT** to save the setting and return to the previous menu.
There is a confirmation tone. To exit without making changes, press **CANCEL**.

AUTO-MUTE

Use this feature to choose whether a page will broadcast on your deskset when you receive a page.

If you set **AUTO-MUTE** to **Off**, you can hear on the deskset when you receive a page. If you set **AUTO-MUTE** to **On**, the **MUTE** light turns on, and a page is muted when you receive a page, unless you press **MUTE** to unmute the page.

1. When the telephone is idle, press **MENU/SELECT**.
2. Press ▲ or ▼ to scroll to **Phone Settings** then press **MENU/SELECT**.
3. Press ▲ or ▼ to scroll to **AUTO-MUTE** then press **MENU/SELECT**.
4. Press ▲ or ▼ to choose **On** or **Off**.
5. Press **MENU/SELECT** to save the setting and return to the previous menu.
There is a confirmation tone. To exit without making changes, press **CANCEL**.

Telephone setup

Hold reminder

When this feature is on and there is a call on hold for more than three minutes, the deskset beeps once every 30 seconds.

To turn this feature on or off:

1. When the telephone is idle, press **MENU/SELECT**.
2. Press ▲ or ▼ to scroll to **Phone Settings** then press **MENU/SELECT**.
3. Press ▲ or ▼ to scroll to **Hold reminder** then press **MENU/SELECT**.
4. Press ▲ or ▼ to scroll to **On** or **Off**.
5. Press **MENU/SELECT** to save the setting and return to the previous menu. There is a confirmation tone. To exit without making changes, press **CANCEL**.

Voice announce

The caller ID announce feature lets you know who is calling without having to look at the display. When you have an incoming call, the handset and/or base speaks "Call from..." and the name of the caller based on the directory or caller ID information. If the caller's name is private or unknown, the phone number up to the last 11 digits will be announced. If the caller's phone number is also private or unknown, no information will be announced. By default, the caller ID announce feature is programmed **On**.

To change the setting:

1. When the telephone is idle, press **MENU/SELECT**.
2. Press ▲ or ▼ to scroll to **Phone Settings** then press **MENU/SELECT**.
3. Press ▲ or ▼ to scroll to **Voice Announce** then press **MENU/SELECT**.
4. Press ▲ or ▼ to scroll to **On** or **Off**.
5. Press **MENU/SELECT** to save the setting and return to the previous menu. There is a confirmation tone. To exit without making changes, press **CANCEL**.

Telephone setup

Phone rename

Use this feature to rename the deskset (up to 12 characters).

To change the setting:

1. When the telephone is idle, press **MENU/SELECT**.
2. Press ▲ or ▼ to scroll to **Phone Settings** then press **MENU/SELECT**.
3. Press ▲ or ▼ to scroll to **Phone Rename** then press **MENU/SELECT**.
4. Use the dialing key keys to change the name.
 - Press ◀/REPEAT or ▶/SKIP to move the cursor left or right.
 - Press **DELETE** to delete a character.
 - Press and hold **DELETE** to delete all characters.
5. Press **MENU/SELECT** to save the setting and return to the previous menu. There is a confirmation tone. To exit without making changes, press **CANCEL**.

Set default

Use this feature to reset all feature settings for this Console to their default settings. The messages stored in the mailbox will not be reset.

To reset all feature settings to default:

1. When the telephone is idle, press **MENU/SELECT**.
2. Press ▲ or ▼ to scroll to **Phone Settings** then press **MENU/SELECT**.
3. Press ▲ or ▼ to scroll to **Set Default**.
4. Press **MENU/SELECT**. There is a confirmation tone.

Customer support

Use this feature to display the AT&T website.

1. When the telephone is idle, press **MENU/SELECT**.
2. Press ▲ or ▼ to scroll to **Customer Support** then press **MENU/SELECT**.
3. Press **CANCEL** to return to the previous menu.

Telephone basic operation

The telephone comes programmed to use line 1 (default primary line) for calls when you do not press a line key. When you answer a call, the telephone automatically selects the ringing line.

Line indicators

Each of the four indicators on **LINE 1-LINE 4** indicate the state of the corresponding telephone line.

- On when the corresponding line is in use.
- Flashes slowly when the line is on hold.
- Flashes slowly when there is an incoming auto attendant answering or transferring call on the corresponding line.
- Flashes rapidly when there is an incoming call or a transferring call on the corresponding line.

Making a call

To make a call from the deskset:

1. Lift the handset or press  **SPEAKER**.

-OR-

To override automatic line selection, press **LINE 1-LINE 4** for the desired line, then lift the handset.

2. Wait for a dial tone, then enter the telephone number. The screen displays the elapsed time as you talk (in hours, minutes and seconds).

To end a call from the deskset:

- Place the handset on the deskset to hang up.

-OR-

- If you are using the speakerphone, press  **SPEAKER** to hang up.



NOTE: The elapsed time is not affected by accessing services from your telephone service provider.

Telephone basic operation

To make a call with a corded headset:

Make sure a corded headset is connected to the deskset (page 15).

1. Press **HEADSET** on the deskset.
2. Wait for a dial tone, then dial the number.
3. To hang up, press **HEADSET**.

To make a call with a cordless headset:

You can make a call using a registered cordless headset and the dial pad on the deskset.

1. Press the **ON/OFF** button on the cordless headset.
2. Wait for a dial tone, then dial the number on the base.
3. To hang up, press the **ON/OFF** button.

On hook dialing (predialing)

1. Enter the telephone number. Press **DELETE** to make corrections.
2. Lift the handset or press **SPEAKER** to dial.

-OR-

To override automatic line selection, press **LINE 1-LINE 4** for the desired line, then lift the handset.

Using the speakerphone

During a call, press **SPEAKER** to switch between handsfree speakerphone and normal handset use. Press **SPEAKER** again or place the handset on the deskset to hang up.

Answering a call

To answer a call:

- Lift the handset, press **SPEAKER**, **HEADSET** or the **ON/OFF** button on a registered cordless headset.

-OR-

To override automatic line selection, press **LINE 1-LINE 4** for the desired line, then lift the handset.

Temporary ringer silencing

Press **MUTE** while the telephone is ringing to silence the ringer temporarily on the deskset only. This turns off the ringer without disconnecting the call. The next incoming call rings normally at the preset volume.

Telephone basic operation

Redial

The last 10 telephone numbers dialed (up to 32 digits) are stored in system memory.

To view and dial the 10 most recently dialed numbers:

1. Press **AUTO REDIAL** to enter the redial list and display the most recently called number.
2. Press ▲ or ▼ to view other recently called numbers.
3. Press **CANCEL** to exit the redial list.

To redial a number:

- To dial the displayed number, lift the handset, or press **◀▶ SPEAKER** or **HEADSET**.
- To override automatic line selection, press **LINE 1-LINE 4** for the desired line, then lift the handset.

To delete a number:

- While the screen displays the desired number, press **DELETE** to delete the number from the redial memory.

Telephone basic operation

Auto-redial

Use this feature to automatically redial a number up to ten times. The telephone uses the prime line to redial numbers if you have set the prime line (page 18).

1. Press the desired line when necessary.
2. Press **AUTO REDIAL** to enter the redial list and display the most recently called number.
3. While the screen displays the desired number, press ◀/REPEAT or ▶/SKIP to choose **Auto redial**, then press MENU/SELECT.
4. The telephone calls the desired number using the speakerphone. The screen displays **Redial in XX secs**.
5. When the other party answers, you will need to take an action to speak with the other party. To answer the call, lift the handset, press 🔊 **SPEAKER** or **HEADSET**.

While auto-redial is active:

- After a call is placed, if the line is busy, you will hear a busy tone for five seconds before the set hangs up. Thirty seconds later, the call will be redialed.
- This process repeats up to 10 times or until the called number is no longer busy. If the line is still busy after 10 attempts, no more attempts are made.
- If the line is ringing but no party answers after two attempts, no more attempts are made.
- If you want to turn off the auto-redial feature during the 30-second waiting time, press **CANCEL**.

Options while on calls

Call waiting

If you subscribe to call waiting service with your telephone service provider, you hear a beep if someone calls while you are in the middle of a call.

- Press **FLASH** to put your current call on hold and take the new call.
- Press **FLASH** at any time to switch back and forth between calls.

Volume control

Use this feature to independently set the listening volume to one of six levels for each of the listening options (corded handset, corded headset and speakerphone). While using each, press **▲VOLUME▼** to adjust the listening volume.

While adjusting the volume for the corded handset or the corded headset you hear a triple beep when you reach the minimum or maximum volume setting.

Options while on calls

Mute

Use this feature during a telephone conversation to silence the microphone. You can hear the caller, but the caller cannot hear you.

To mute a call:

- Press **MUTE**. When mute is on, the **MUTE** light flashes; the screen also displays **MUTE**.

To take a call off mute:

- Press **MUTE** again and resume speaking.



NOTE: Transferring the call, changing lines or putting a call on hold also cancels the mute function.

Temporary tone dialing

If you have dial pulse (rotary) service only, use this feature to temporarily switch dial pulse to touch-tone dialing during a call by pressing **TONEX**.

During a call:

1. Press **TONEX**.
2. Use the dialing keys to enter the relevant number. The telephone sends touch-tone signals.

The telephone automatically returns to pulse dialing mode after you end the call.

Options while on calls

Hold

Use this feature to hold one line while accessing another, or as part of the conference and call transfer features.

While on a call, press and release **HOLD**. The **LINE 1-LINE 4** indicator for the line on hold flashes slowly. After the call has been on hold for more than three minutes, a beep sounds every 30 seconds. (To turn off the reminder beep, see **Hold reminder** on page 34).

If you are using the speakerphone, the speakerphone turns off automatically when you press **HOLD**.

To release the hold, press and release **LINE 1-LINE 4** of the call on hold.



NOTES:

1. A call on hold after 10 minutes is automatically forwarded to the auto attendant, even if the auto attendant is not activated. To keep a call on hold longer than 10 minutes, release the held call within 10 minutes and then place the call on hold again.
2. You cannot put an intercom call on hold.

Switching between lines

Use this feature to switch between lines during an outside call:

1. Press **LINE 1-LINE 4** of another telephone line to make or answer another call. The current call is put on hold automatically.
2. To return to the first call, press the original **LINE 1-LINE 4**. The second line is put on hold automatically.

Options while on calls

Call privacy

To ensure call privacy, this telephone allows only one set at a time to use a line. You can also block all system handsets from joining a phone conversation (see page 45 for instructions for joining calls).

To enable call privacy:

- During the call, press **MENU/SELECT** to select **Call Privacy**. Press ▲ or ▼ to choose **On**, then press **MENU/SELECT**. Any other extensions are dropped and no extensions can join the call. If another extension tries to access the line you are using, its screen displays **Privacy**.

To cancel call privacy:

- During the call, press **MENU/SELECT** to select call privacy. Press ▲ or ▼ to choose **Off**, then press **MENU/SELECT**. Other telephones can now join the call by pressing the appropriate line key.



NOTES:

1. Call privacy is automatically canceled when you end a call.
2. You cannot set call privacy during intercom or conference calls.
3. Call privacy applies only to system telephones. It does not affect non-system phones using the same line(s).

Options while on calls

Chain dialing

While you are on a call, you can initiate a dialing sequence from the numbers in the directory.

Chain dialing can be useful if you wish to access other numbers (such as bank account numbers or access codes) from the directory.

To access the directory while on a call:

1. During the call, press **DIRECTORY**, then press ▲ or ▼ to scroll to the desired entry.
2. Press **MENU/SELECT** to dial the desired entry. To exit without making changes, press **CANCEL** and continue with the conversation.

To access the call history while on a call:

1. During the call, press **CALL HISTORY**, then press ▲ or ▼ to scroll to the desired entry.
2. Press **MENU/SELECT** to dial the desired entry. To exit without making changes, press **CANCEL** and continue with the conversation.



NOTE: You cannot edit a directory entry while on a call. See pages 51-55 for more details about the directory.

To access the one touch entry while on a call:

1. During the call, press the desired one touch key to dial an entry in the upper location.

-OR-

During the call, press **LOWER**, then press the desired one-touch key to dial an entry in the lower location.

Options while on calls

Join a call in progress

Use this feature to join in an ongoing call on any line that does not have call privacy set (see **Call privacy** on page 43 for more information). The screen displays **Conf.** when the line is in use.

- Press and hold the desired **LINE 1-LINE 4** on the deskset to join in the call, which becomes a three-way conference (page 45).



NOTE: When you try to join an ongoing call on a line with call privacy on, the screen displays **Privacy** and you hear four beep tones.

Conference calls

Use this feature to set up a conference call by using two lines at the same time. You can also join an intercom call with a call on an outside line. The outside line call must be established first because an intercom call cannot be placed on hold.

The system supports a maximum of three extensions to have conference call with two outside calls at a time.

To make a conference call:

1. Make or answer an outside call.
2. Press **HOLD** and call someone on another line, or start an intercom connection.

-OR-

Call someone on another line, or intercom someone. The first line is automatically put on hold.

3. Press **CONFERENCE** at any time to begin the conference call.

To talk privately with one party:

1. Press **HOLD** to place both lines on hold.
2. Press **LINE 1-LINE 4** to talk privately with the person on that line.
3. Press **CONFERENCE** to resume the conference call.

To drop one line:

1. Press **LINE 1-LINE 4** to activate the line you want to drop and place the handset on the deskset to hang up or press **SPEAKER**. The other line is put on hold automatically.
2. Press **LINE 1-LINE 4** to resume the call and lift the handset on the deskset.

Options while on calls

To drop an intercom:

- Press **LINE 1-LINE 4** to activate the external call. The intercom call drops automatically.

To end a conference call:

- Place the handset on the deskset to hang up or press  **SPEAKER**. The call does not terminate until all extensions hang up.



NOTES:

1. If an internal party hangs up, the ongoing call becomes a two-way conversation.
2. You cannot make any conference calls if all four telephone lines are in use.
3. If you are experiencing difficulty in using the conference features on this telephone, please consider using AT&T's complete line of teleconference services to find a solution that best meets your needs. AT&T TeleConference Services reduces travel time and expenses while increasing productivity wherever people are located, enabling you to host truly virtual meetings and share important information in real time. To sign up for AT&T TeleConference Services, go to: **www.att.com/orderconference** for details.

Intercom

You can use the intercom feature for conversations between the system and an accessory device, or between two accessory devices. When the system is on one or more external calls, accessory devices can make intercom calls with each other. If you have a cordless headset, it can only receive intercom calls.

Each individual phone in the telephone system **MUST** be assigned a unique extension number for the intercom feature to work. The assignment is done automatically when the phone is initially setup.



NOTE: A deskset connected to AC power but not to any telephone lines can still intercom with charged and registered accessory cordless accessory.

Make an intercom call to an extension

1. Press **INTERCOM** on the deskset while on a call:
2. Press **MENU/SELECT** to choose **Intercom**.
3. Press the desired one touch location, refer to **To dial a one-touch entry** on page 28.

-OR-

Press **▲** or **▼** to scroll to a desired extension, then press **MENU/SELECT**.

4. The screen displays **Intercom to: Device X** (**Device X** represents the name of destination device).



NOTES:

1. Before the intercom call is answered, you can cancel the intercom by pressing **CANCEL** or **END**.
2. The intercom call automatically cancels if the call is unanswered after one minute.
3. Press **MUTE** to temporarily silence the intercom ringer.

Answer an intercom call

When you receive an intercom call, you hear a ringing tone and your screen displays **Intercom from: Device X** (**Device X** represents the name of the calling device). Lift the handset or press **SPEAKER** to answer.

End an intercom call

Place the handset back to the deskset or press **SPEAKER** if you are using the speakerphone.

Answer an incoming call during an intercom call

If you receive an incoming outside call during an intercom call, there is an alert tone.

To answer the call, press **LINE 1-LINE 4**. The intercom call ends automatically.

Call transfer

You can transfer a call to any other system telephone. Once you transfer a call, it can be answered by any system telephone, not just at the extension you called.

Blind transfer

While on a call, you can transfer a call directly without notifying the desired extension:

1. Press **TRANSFER** on the deskset while on a call:
2. Press the one-touch key for the desired extension, refer to **To dial a one-touch entry** on page 28.

-OR-

Press ▲ or ▼ to scroll to the desired extension, then press **MENU/SELECT**.

3. The current line is put on hold. The destination handset rings and the call is answered by pressing **LINE 1-LINE 4**. You hear a short tone from the deskset. The outside call is automatically transferred to the desired extension.
4. Put the corded handset on the deskset or press **▶ SPEAKER** to hang up.

-OR-

You can resume the call by pressing the corresponding flashing line key **LINE 1-LINE 4** before the desired extension answers the call.

You hear a beep tone every 30 seconds when a transferred call has not been answered (To turn off the reminder beep, see **Hold reminder** on page 34).



NOTES:

1. If the desired extension does not answer the intercom call within one minute, the extension rings as an incoming call to remind the extension user.
2. If the outside call is put on hold for 10 minutes, it is automatically transferred to the auto attendant. The deskset returns to idle mode.

Call transfer using intercom

Transfer a call and speak to the receiving party

You can transfer a call and speak to the receiving party before completing the transfer while on a call:

1. Press **INTERCOM** on the deskset while on a call:
2. Press **MENU/SELECT** to choose **Intercom**.
3. Press the desired one touch location, refer to **To dial a one-touch entry** on page 28.

-OR-

Press ▲ or ▼ to scroll to a desired extension, then press **MENU/SELECT**.

4. The current line is put on hold. The destination extension rings and the call is answered. You can now talk to the destination party.
5. Press **TRANSFER** to transfer the call to the destination extension.

You hear a beep tone every 30 seconds when a transferred call has not been answered (To turn off the reminder beep, see **Hold reminder** on page 34).



NOTE: If the desired extension does not answer the intercom call within one minute, the extension rings as an incoming call to remind the extension user.

Answer a transferred call

When you hear a short intercom ring from the deskset:

Lift the handset to intercom with an extension. You can talk privately with the extension before picking up the outside call that is on hold. Press the blinking **LINE 1-LINE 4** when you are ready to talk to the outside call.

Other options for answering the transferred call:

- To answer using the deskset speakerphone, press **☎** **SPEAKER** before pressing **LINE 1-LINE 4**.
- To answer handsfree using the corded headset, press **HEADSET** before pressing **LINE 1-LINE 4**.

Voice page

You can directly broadcast messages to the speakerphone of any extension. The extension you called can respond by pressing the **INTERCOM** to begin a two-way communication. Any registered cordless handset/deskset can make a page with each other or with the main console.

Page a single device

1. Press **INTERCOM** on the deskset while on a call:
2. Press ▲ or ▼ to scroll to **Page**, then press **MENU/SELECT**.
3. Press ▲ or ▼ to scroll to a desired extension, then press **MENU/SELECT**.
4. When the connection is made, both the caller and the destination party hear three beeps. Speak into the base speakerphone. Your voice is broadcast to the desired extension.
5. The destination party can now respond.

Page all devices

1. Press **INTERCOM** on the deskset while on a call:
2. Press ▲ or ▼ to scroll to **Page all**, then press **MENU/SELECT**.
3. Press ▲ or ▼ to scroll to a desired extension, then press **MENU/SELECT**.
4. When the connection is made, both the caller and the destination party hear three beeps. Speak into the base speakerphone. Your voice is broadcast to the desired extension.

Answer a page

1. Press **INTERCOM** on the deskset while on a call:
2. Press ▲ or ▼ to scroll to **Page all**, then press **MENU/SELECT**.
3. Press ▲ or ▼ to scroll to a desired extension, then press **MENU/SELECT**.
4. When the connection is made, both the caller and the destination party hear three beeps. Speak into the base speakerphone. Your voice is broadcast to the desired extension.

End a page

- Press **INTERCOM**, **SPEAKER** or place the handset back to the deskset to end page.

About the directory

Use the directory to store names and phone numbers. Directory entries are not shared with other extensions. Each extension has its own directory.

Capacity

The directory of this deskset can store up to 50 entries, with a maximum of 15 alphanumeric characters (including spaces) for names and 30 digits for telephone numbers. A convenient search feature can help you quickly find and dial numbers (page 53).

If there are already 50 entries, the screen shows **Memory is full**. You cannot store a new number until you delete one. If you try to view the directory when there are no entries, the screen displays **Directory empty**.

Create directory entries

Create a new directory entry

Use the following steps to store a name and number in the directory.

1. When the telephone is idle, press **DIRECTORY**.
2. Press **MENU/SELECT** to add an entry.
3. Use the dialing keys to enter the name.
 - Press **DELETE** to delete a character.
 - Press and hold **DELETE** to delete all characters.
 - Press **◀/REPEAT** or **▶/SKIP** to move the cursor to the left or right.
4. Press **MENU/SELECT** to save. Use the dialing keys to enter the number.
 - Press **DELETE** to delete a digit.
 - Press and hold **DELETE** to delete all digits.
 - Press **◀/REPEAT** or **▶/SKIP** to move the cursor to the left or right.
 - You can include a pause while storing a dialing sequence that requires one during actual dialing. Press **▲** or **▼** to choose **◆Add Pause**, then press **MENU/SELECT**. A **P** appears on the screen.
 - **Store a signal for switching to temporary tone signalling.** If you have dial pulse (rotary) service, this signal is required for some special services. Press **▲** or **▼** to choose **◆Add Tone**, then press **MENU/SELECT**. A **T** appears on the screen. All numbers you enter after this will send touch-tone signals during dialing.
 - Store a signal for switch to temporary tone dialing. Press **▲** or **▼** to choose **◆Add Tone**, then press **MENU/SELECT**. A **T** appears on the screen. All numbers you enter after this will send touch-tone signals during dialing.
 - You can store the flash signal required by some special services as part of a dialing sequence. Press **▲** or **▼** to choose **◆Add Flash**, then press **MENU/SELECT**. A **F** appears on the screen.
5. Press **◀/REPEAT** or **▶/SKIP** to choose **Done**, then press **MENU/SELECT**. To exit without making changes, press **CANCEL**.

Review directory entries

1. When the telephone is idle, press **DIRECTORY**.
2. Press **▲** or **▼** to browse through the directory. Entries appear alphabetically by the first letter in the name.
3. Press **CANCEL** to cancel an operation and return to idle mode.

Search directory

Search by name

Follow the steps below to search for directory entries on the deskset.

1. When the telephone is idle, press **MENU/SELECT** twice to select **Directory**.
-OR-
Press **DIRECTORY** on the deskset.
2. Press **▲** or **▼** to browse through the directory.
3. When a name appears, press the dial pad keys (**2-9**) to start a name search.
 - The directory shows the first name beginning with the first letter associated with the dial pad key if there is an entry in the directory beginning with that letter. If there is no entry matching the letter you press, it remains in the current entry.
4. To see other names starting with the letters on the same dial pad key, keep pressing the key. The names appear in alphabetical order.

For example, if you have the names **Jennifer**, **Jessie**, **Kevin** and **Linda** in your directory:

- If you press **5 (JKL)** once, you see **Jennifer**.
- If you press **5 (JKL)** twice, you see **Kevin**.
- If you press **5 (JKL)** three times, you see **Linda**.
- If you press **5 (JKL)** four times, you see **Jennifer**.
- To view **Jessie**, press **▼** while **Jennifer** is displayed.

Dial, delete or edit entries

You can dial, delete or edit a directory entry (name and number) when it is shown on the deskset screen. You can use the directory review (page 52) or search (page 53) to show an entry.

Display dial

When a number is displayed on the screen, you can dial the number by lifting the corded handset, pressing **◀** **SPEAKER** or **LINE 1-LINE 4** for the desired line.

Delete an entry

1. When a directory entry appears, press **DELETE** .
2. The screen displays **Delete Contact?** Press **MENU/SELECT** to confirm. You hear a confirmation tone.

Edit an entry

1. When a directory entry appears, press **MENU/SELECT**.
2. Use the dialing keys to edit the name.
 - Press **DELETE** to delete a character.
 - Press and hold **DELETE** to delete all characters.
 - Press **◀/REPEAT** or **▶/SKIP** to move the cursor to the left or right.
3. Press **MENU/SELECT** to save. Use the dialing keys to edit the number.
 - Press **DELETE** to delete a digit.
 - Press and hold **DELETE** to delete all digits.
 - Press **◀/REPEAT** or **▶/SKIP** to move the cursor to the left or right.
 - You can include a pause while storing a dialing sequence that requires one during actual dialing. Press **▲** or **▼** to choose **◆Add Pause**, then press **MENU/SELECT**. A **P** appears on the screen.
 - **Store a signal for switching to temporary tone signalling.** If you have dial pulse (rotary) service, this signal is required for some special services. Press **▲** or **▼** to choose **◆Add Tone**, then press **MENU/SELECT**. A **T** appears on the screen. All numbers you enter after this will send touch-tone signals during dialing.
 - You can store the flash signal required by some special services as part of a dialing sequence. Press **▲** or **▼** to choose **◆Add Flash**, then press **MENU/SELECT**. A **F** appears on the screen. Continue storing the number as usual.
4. Press **◀/REPEAT** or **▶/SKIP** to choose **◆Done**, then press **MENU/SELECT**. To exit without making changes, press **CANCEL**.

Caller ID operation

Memory match

If the incoming telephone number is an exact match with a telephone number in your directory, the name that appears on the screen matches the corresponding name in your directory.

For example, if Christine Smith calls, her name appears as Chris if this is how you entered it into your directory.



NOTE: The number you see on your caller ID is in the format from the telephone service provider. It usually delivers 10-digit telephone numbers (area code plus telephone number). The telephone system ignores the area code when searching for a match and displays the name of the first corresponding number from the directory.

Missed (new) calls indicator

When the deskset is in idle mode and has new or missed calls, its screen shows **XX Missed call(s)**.

All new or missed entries are counted as missed calls. Each time you review a call history entry with the icon **new**, the number of missed calls decreases by one. When all the entries in the caller ID information become old (have been reviewed), the system removes the missed calls alert from the display, and the **NEW** indicator turns off.

Review the caller ID information

1. When the telephone is idle, press **CALL HISTORY**.
2. Press ▲ or ▼ to review the caller ID information. The call history entries are stored in reverse chronological order starting with the most recent entry.
3. To exit without making changes, press **CANCEL**.

Caller ID operation

View dialing options

Although the incoming call history entries have 10 digits (the area code plus the seven-digit number), in some areas, you may need to dial the seven digits only, 1 plus the seven digits, or 1 plus the area code plus the seven digits. You can change and store the number of digits that you dial in the call history.

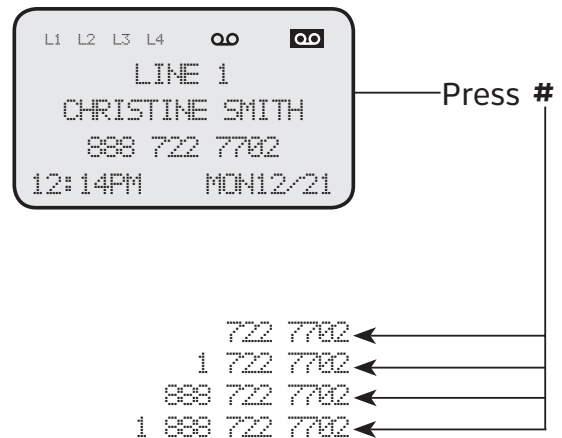

While reviewing the call history, press # (pound key) repeatedly on the deskset to show different dialing options for local and long distance numbers before dialing or saving the telephone number in the directory.

Dial a call history entry

1. When in the call history, press ▲ or ▼ to browse the number you wish to call.
2. Lift the handset or press **SPEAKER**.

-OR-

To override automatic line selection, press **LINE 1-LINE 4** for the desired line, then lift the handset.

Delete entries

Delete a call history entry:

1. When in the call history, press ▲ or ▼ to browse to the number you wish to delete.
2. Press **DELETE** to delete the shown entry from the caller ID history.

Delete all call history entries:

1. When the telephone is idle, press **CALL HISTORY**.
2. Press **DELETE**. The screen displays **All calls deleted** and there is a confirmation tone, then returns to the idle screen.

Caller ID operation

Save a call history entry to the directory

1. When in the call history, press ▲ or ▼ to browse the desired number to save.
2. Press **MENU/SELECT**, then press ▲ or ▼ to choose **Copy to DIR**.
3. Press **MENU/SELECT**. Use the dialing keys to edit the name.
 - Press **DELETE** to delete a character.
 - Press and hold **DELETE** to delete all characters.
 - Press ◀/**REPEAT** or ▶/**SKIP** to move the cursor to the left or right.
4. Press **MENU/SELECT** to save. Use the dialing keys to edit the number.
 - Press **DELETE** to delete a digit.
 - Press and hold **DELETE** to delete all digits.
 - Press ◀/**REPEAT** or ▶/**SKIP** to move the cursor to the left or right.
 - You can include a pause while storing a dialing sequence that requires one during actual dialing. Press ▲ or ▼ to choose **◆AddPause**, then press **MENU/SELECT**. A **P** appears on the screen.
 - **Store a signal for switching to temporary tone signalling.** If you have dial pulse (rotary) service, this signal is required for some special services. Press ▲ or ▼ to choose **◆Add Tone**, then press **MENU/SELECT**. A **T** appears on the screen. All numbers you enter after this will send touch-tone signals during dialing.
 - You can store the flash signal required by some special services as part of a dialing sequence. Press ▲ or ▼ to choose **◆Add Flash**, then press **MENU/SELECT**. A **F** appears on the screen. Continue storing the number as usual.
5. Press ◀/**REPEAT** or ▶/**SKIP** to choose **◆Done**, then press **MENU/SELECT**. To exit without making changes, press **CANCEL**.



NOTE: You will need to change how a caller ID number is dialed if the entry does not appear in the correct format. Caller ID numbers might appear with an area code that might not be necessary for local calls, or without a 1 that might be necessary for long distance calls (see **View dialing options** on the previous page for more information).

Reasons for missing caller ID information

Reasons for missing caller ID information

There are also occasions when other information or no information shows for various reasons:

On-screen message	Reason
PRIVATE NAME	The caller prefers not to show the name.
PRIVATE NUMBER	The caller prefers not to show the phone number.
PRIVATE CALLER	The caller prefers not to show the phone number and name.
UNKNOWN NAME	Your telephone service provider cannot determine the caller's name.
UNKNOWN NUMBER	Your telephone service provider cannot determine the caller's number.
UNKNOWN CALLER	No information is available about this caller.

Private mailbox setup

You can set your deskset as a private mailbox in the telephone system. The private mailbox can answer a call when the telephone system turn off the auto attendant feature, the auto attendant is busy or run out of recording memory, or the telephone system set a shorter private mailbox delay than the auto attendant delay.

Private mailbox on/off

You can turn the private mailbox on or off.

1. When the telephone is idle, press **ANS SYS**.
2. Press ▲ or ▼ to scroll to **Private Mailbox** then press **MENU/SELECT**.
3. Press ▲ or ▼ to scroll to **Priv MB ON/OFF** then press **MENU/SELECT**.
4. Press ▲ or ▼ to choose **ON** or **OFF**.
5. Press **MENU/SELECT**. There is a confirmation tone.

Private mailbox delay

Use this feature to choose how long this phone rings before the private mailbox picks up a call. One cycle lasts about six seconds.

1. When the telephone is idle, press **ANS SYS**.
2. Press ▲ or ▼ to scroll to **Private Mailbox** then press **MENU/SELECT**.
3. Press ▲ or ▼ to scroll to **Auto ATT Delay** then press **MENU/SELECT**.
4. Press ▲ or ▼ to choose the desired time (**12 seconds** to **40 seconds**).
5. Press **MENU/SELECT**. There is a confirmation tone.

Announcement

An announcement plays when calls are answered by the private mailbox. The system has a default announcement, *"Hello, please leave a message after the tone."* You can use this announcement or record your own.

You can record an announcement up to 75 seconds.

To record the announcement:

1. When the telephone is idle, press **ANS SYS**.
2. Press ▲ or ▼ to scroll to **Private Mailbox** then press **MENU/SELECT**.
3. Press ▲ or ▼ to scroll to **Announcement** then press **MENU/SELECT**.
4. Press ▲ or ▼ to scroll to **Record** then press **MENU/SELECT**.
5. The screen displays **Record OGM** and the time elapsed. Press **MENU/SELECT** to select **STOP** to stop recording. The console beeps and plays the recorded announcement. To exit without making changes, press **CANCEL**.

Private mailbox setup

To play the announcement:

1. When the telephone is idle, press **ANS SYS**.
2. Press ▲ or ▼ to scroll to **Private Mailbox** then press **MENU/SELECT**.
3. Press ▲ or ▼ to scroll to **Announcement** then press **MENU/SELECT**.
4. Press ▲ or ▼ to scroll to **Play** then press **MENU/SELECT**.
5. The screen displays **Play OGM** and the time elapsed. Press ◀/REPEAT or ▶/SKIP to select **STOP** to stop the announcement, **PLAY** to play the announcement, **RECORD** to record a new announcement or **RESET** to reset the announcement to default.

Delete all private mailbox messages

You can use this feature to delete all messages stored in the private mailbox.

1. When the telephone is idle, press **ANS SYS**.
2. Press ▲ or ▼ to scroll to **Private Mailbox** then press **MENU/SELECT**.
3. Press ▲ or ▼ to scroll to **Delete all msgs** then press **MENU/SELECT**.
4. The screen displays **Delete all messages?** Press **MENU/SELECT** to confirm. There is a confirmation tone. To exit without making changes, press **CANCEL**.

Record memo

Memos are messages you record as reminders for yourself. You can record your own memos using a system handset. Play and delete them the same way as incoming messages.

1. When the telephone is idle, press **ANS SYS**.
2. Press ▲ or ▼ to scroll to **Private Mailbox** then press **MENU/SELECT**.
3. Press ▲ or ▼ to scroll to **Record memo** then press **MENU/SELECT**.
4. Press ▲ or ▼ to scroll to **Record** then press **MENU/SELECT**.
5. Facing the deskset, record your memo. The screen displays **Record memo** and the time elapsed. Press **MENU/SELECT** to select **STOP** to stop recording. To exit without making changes, press **CANCEL**.

Private mailbox setup

Call intercept

Choose whether private incoming messages can be intercepted by other extension phones. If call intercept is on when a caller leaves a message, someone on another extension phone sharing the same line can answer the call by pressing the corresponding line key.

1. When the telephone is idle, press **ANS SYS**.
2. Press ▲ or ▼ to scroll to **Private Mailbox** then press **MENU/SELECT**.
3. Press ▲ or ▼ to scroll to **Call intercept** then press **MENU/SELECT**.
4. Press ▲ or ▼ to choose **On** or **Off**.
5. Press **MENU/SELECT** to save the setting and return to the previous menu. There is a confirmation tone. To exit without making changes, press **CANCEL**.

Answering system setup

Remote access code

Use this code to select a three-digit number to allow remote access of private mailbox from another telephone. You can change the code to any number from **000-999**. This code is **111** by default.

1. When the telephone is idle, press **ANS SYS**.
2. Press **▲** or **▼** to scroll to **Ans Sys Setup** then press **MENU/SELECT**.
3. Press **▲** or **▼** to scroll to **Remote Code** then press **MENU/SELECT**.
4. The screen displays **Set Remote Code**. Use the dialing keys to enter a three-digit remote code.
 - Press **DELETE** to delete a digit.
 - Press and hold **DELETE** to delete all digits.
 - Press **◀/REPEAT** or **▶/SKIP** to move the cursor to the left or right.
5. Press **MENU/SELECT** to save the setting and return to the previous menu. There is a confirmation tone. To exit without making changes, press **CANCEL**.

Message alert

Use this feature to turn the audible message alert on or off.

If the message alert tone is on, the telephone beeps every 30 seconds when there are new private or central messages.

1. When the telephone is idle, press **ANS SYS**.
2. Press **▲** or **▼** to scroll to **Ans Sys Setup** then press **MENU/SELECT**.
3. Press **▲** or **▼** to scroll to **Message Alert** then press **MENU/SELECT**.
4. Press **▲** or **▼** to choose **On** or **Off**.
5. Press **MENU/SELECT** to save the setting and return to the previous menu. There is a confirmation tone. To exit without making changes, press **CANCEL**.

Answering system setup

Message Length

Use this feature to set the maximum length of recorded messages.

You can select the maximum length for the messages callers can record. If you choose **Greeting only**, the caller hears the selected announcement but is not able to record a message. If you choose **1 minute**, **2 minutes** or **3 minutes**, the caller can record a message up to one minute, two minutes or three minutes. If you choose **Unlimited**, the caller can record a message of any length, up to the amount time remaining for all messages, memos, and announcement.

1. When the telephone is idle, press **ANS SYS**.
2. Press ▲ or ▼ to scroll to **Ans Sys Setup** then press **MENU/SELECT**.
3. Press ▲ or ▼ to scroll to **Message Alert** then press **MENU/SELECT**.
4. Press ▲ or ▼ to choose **Greeting only**, **1 minute**, **2 minutes**, **3 minutes**, or **Unlimited**.
5. Press **MENU/SELECT** to save the setting and return to the previous menu. There is a confirmation tone. To exit without making changes, press **CANCEL**.

Call screening

Use this feature to choose whether incoming messages can be heard over the speaker when they are being recorded. If you turn call screening on, you hear the incoming message on your telephone when a call comes in.

1. When the telephone is idle, press **ANS SYS**.
2. Press ▲ or ▼ to scroll to **Ans Sys Setup** then press **MENU/SELECT**.
3. Press ▲ or ▼ to scroll to **Call Screening** then press **MENU/SELECT**.
4. Press ▲ or ▼ to choose **On** or **Off**.
5. Press **MENU/SELECT** to save the setting and return to the previous menu. There is a confirmation tone. To exit without making changes, press **CANCEL**.

Record time

Use this feature to check the amount of space currently in the system for the estimated remaining recording time and number of messages.

1. When the telephone is idle, press **ANS SYS**.
2. Press ▲ or ▼ to scroll to **Recording Time** then press **MENU/SELECT**.
3. Press **CANCEL** to return to the previous menu.

Answering system operation

New message indication

The  displays on the deskset when there are new messages and memos in the private mailbox.

The **MESSAGE WAITING** indicator on the Condole flashes when there are messages in private mailbox.

Message playback

From the deskset, you can play the messages in both the private mailbox.

If you have new messages, you hear only the new messages (in chronological order). If there are no new messages, the system plays back all the messages (in chronological order).

When playback begins, the total number of messages is announced. Before each message, you hear the date and time of the recording. After the last message, you hear *“End of the messages.”*

To listen to messages in the mailbox:

1. While the telephone is idle, press **ANS SYS** on the deskset.
2. Press **▲** or **▼** to choose **Play new msgs** to play the new message only or **Play all msg** to play all the messages in the mailbox.
3. Press **MENU/SELECT** to play the messages.
4. The system announces the number of new or missed messages in the mailbox.

Options during playback

When a message is playing, you can adjust the playback volume, skip, repeat, or delete the message.

When a message is playing on the Console:

- Press **▲/VOLUME+** or **VOLUME/▼** to adjust the message playback volume.
- Press **▶/SKIP** to skip to the next message.
- Press **◀/REPEAT** or to repeat the current message. Press twice to hear the previous message.
- Press **▲** or **▼** to scroll to choose **Pause**, then press **MENU/SELECT** to pause the message playback. Press **▲** or **▼** to scroll to choose **Resume**, then press **MENU/SELECT** to resume.
- Press **DELETE** to delete the message. The system announces *“Message deleted.”*

Remote access

Use this feature to reach your answering system remotely by dialing your telephone number from any touch-tone telephone.

To remotely reach the answering system:

1. Dial your telephone number from any touch-tone telephone.
2. When the system answers, enter the three-digit remote access code (**111** is the default code; see **Remote access code** on page 62 to change it).
The system automatically announces the number of messages (new and/or old) if there are any, and then begins to play them.
3. You can also enter the following remote commands.

Remote commands:

1	Press to play to all messages.
1 X	Press to play all messages.
2	Press within three seconds of the message playing to go back to the previous message. Press after three seconds of the message playing to repeat the message currently playing.
3	Press to delete the current message (during playback).
7	Press to play answering system announcement. <ul style="list-style-type: none"> • Press 9 and wait for the beep before speaking. • Press 8 to stop recording and listen to the playback of the new announcement.
8	Press to stop the message playing.
9	Press to start recording a memo <ul style="list-style-type: none"> • Press 8 to stop recording.
0	Press to turn the private mailbox on or off.
##	Press during a message playback to delete current message.
# X	Press to delete all messages.

4. Hang up to end the call and save all undeleted messages.

Remote access

Cut out the remote access wallet card at the back of this user's manual for quick reference.



NOTES:

1. If you do not enter a valid remote access code, the answering system answers the call as usual and all the voice and digits entered will be recorded as messages stored in your general mailbox.
2. If you do not enter any remote access code, the answering system announces "Thank you for calling," and the call ends.
3. When there is no new message or all the new messages are played during remote access, you hear a help menu listing all features and commands. If there is no command after the help menu is played three times, the call ends automatically.
4. If the memory is full, you hear a two-beep alert tone and the answering system announces, "Memory is full." The deskset screen displays **Message full.** and you cannot record new messages until old ones have been deleted. Check the system remaining space () frequently to maintain availability of space for incoming messages.
5. If you press **4** within five seconds of each message playback start, the previous message plays instead of repeating the current message.

Maintenance

Taking care of your telephone

- Your telephone base contains sophisticated electronic parts, so you must treat it with care.
- Avoid rough treatment.
- Place the corded handset down gently.
- Save the original packing materials to protect your telephone base if you ever need to ship it.

Avoid water

- You can damage your telephone base if it gets wet. Do not use the corded handset in the rain, or handle it with wet hands. Do not install the telephone base near a sink, bathtub or shower.

Electrical storms

- Electrical storms can sometimes cause power surges harmful to electronic equipment. For your own safety, take caution when using electric appliances during storms.

Cleaning your telephone

- Your telephone base has a durable plastic casing that should retain its luster for many years. Clean it only with a soft cloth slightly dampened with water or a mild soap.
- Do not use excess water or cleaning solvents of any kind.

Remember that electrical appliances can cause serious injury if used when you are wet or standing in water. If the telephone base should fall into water, **DO NOT RETRIEVE IT UNTIL YOU UNPLUG THE POWER CORD AND TELEPHONE LINE CORDS FROM THE WALL.** Then pull the unit out by the unplugged cords.

Important safety information



This symbol is to alert you to important operating or servicing instructions that may appear in this user's manual. Always follow basic safety precautions when using this product to reduce the risk of injury, fire, or electric shock.

Safety information

- Read and understand all instructions in the user's manual. Observe all markings on the product.
- Avoid using a telephone during a thunderstorm. There may be a slight chance of electric shock from lightning.
- Do not use the telephone to report a gas leak in the vicinity of the leak. Under certain circumstances, a spark may be created when the adapter is plugged into the power outlet, or when the handset is replaced in its cradle. This is a common event associated with the closing of any electrical circuit. The user should not plug the phone into a power outlet, and should not put a charged handset into the cradle, if the phone is located in an environment containing concentrations of flammable or flame-supporting gases, unless there is adequate ventilation. A spark in such an environment could create a fire or explosion. Such environments might include: medical use of oxygen without adequate ventilation; industrial gases (cleaning solvents; gasoline vapors; etc.); a leak of natural gas; etc.
- Do not use this product near water, or when you are wet. For example, do not use it in a wet basement or shower, or next to a swimming pool, bathtub, kitchen sink, or laundry tub. Do not use liquids or aerosol sprays for cleaning. If the product comes in contact with any liquid, unplug any line or power cord immediately. Do not plug the product back in until it has dried thoroughly.
- Install this product in a protected location where no one can trip over any line or power cords. Protect cords from damage or abrasion.
- If this product does not operate normally, see the **Troubleshooting** section on pages 87-93 of this user's manual. If you cannot solve the problem, or if the product is damaged, refer to the **Limited warranty** section on pages 72-73. Do not open this product except as directed in your user's manual. Opening the product or reassembling it incorrectly may expose you to hazardous voltages or other risks.
- Replace backup battery only as described in your user's manual. Do not burn or puncture batteries — they contain caustic chemicals.
- This power adapter is intended to be correctly oriented in a vertical or floor mount position. The prongs are not designed to hold the plug in place if it is plugged into a ceiling, an under-the-table or cabinet outlet.



Caution: Use only the power adapter provided with this product. To obtain a replacement, visit our website at **www.telephones.att.com** or call **1 (800) 222-3111**. In Canada, dial **1 (866) 288-4268**.

Important safety information

Especially about cordless telephones

- **Electrical power:** The telephone base must be connected to a working electrical outlet. The electrical outlet should not be controlled by a wall switch. Calls cannot be made from the handset if the telephone base is unplugged, switched off or if the electrical power is interrupted.
- **Power adapter:** The power adapter is intended to be correctly oriented in a vertical or floor mount position. The prongs are not designed to hold the plug in place if it is plugged into a ceiling, under-the-table or cabinet outlet.

Precautions for users of implanted cardiac pacemakers

Cardiac pacemakers (applies only to digital cordless telephones):

Wireless Technology Research, LLC (WTR), an independent research entity, led a multidisciplinary evaluation of the interference between portable wireless telephones and implanted cardiac pacemakers. Supported by the U.S. Food and Drug Administration, WTR recommends to physicians that:

Pacemaker patients

- Should keep wireless telephones at least six inches from the pacemaker.
- Should NOT place wireless telephones directly over the pacemaker, such as in a breast pocket, when it is turned ON.
- Should use the wireless telephone at the ear opposite the pacemaker.

WTR's evaluation did not identify any risk to bystanders with pacemakers from other persons using wireless telephones.

Especially about telephone answering systems

Two-way recording: This unit does not sound warning beeps to inform the other party that the call is being recorded. To ensure that you are in compliance with any federal or state regulations regarding recording a telephone call, you should start the recording process and then inform the other party that you are recording the conversation.

SAVE THESE INSTRUCTIONS

FCC part 68 and ACTA

This equipment complies with Part 68 of the FCC rules and with technical requirements adopted by the Administrative Council for Terminal Attachments (ACTA). The label on the back or bottom of this equipment contains, among other things, a product identifier in the format US: AAAEQ##TXXXX. This identifier must be provided to your telephone service provider upon request.

The plug and jack used to connect this equipment to premises wiring and the telephone network must comply with the applicable Part 68 rules and technical requirements adopted by ACTA. A compliant telephone cord and modular plug is provided with this product. It is designed to be connected to a compatible modular jack that is also compliant. An RJ11 jack should normally be used for connecting to a single line and an RJ14 jack for two lines. See Installation Instructions in the user's manual.

The Ringer Equivalence Number (REN) is used to determine how many devices you may connect to your telephone line and still have them ring when you are called. The REN for this product is encoded as the 6th and 7th characters following the US: in the product identifier (e.g., if ## is 03, the REN is 0.3). In most, but not all areas, the sum of all RENs should be five (5.0) or less. For more information, please contact your telephone service provider.

This equipment may not be used with Party Lines. If you have specially wired alarm dialing equipment connected to telephone line, ensure the connection of this equipment does not disable your alarm equipment. If you have questions about what will disable the alarm equipment, consult your telephone service provider or a qualified installer.

If this equipment is malfunctioning, it must be unplugged from the modular jack until the problem has been corrected. Repairs to this telephone equipment can only be made by the manufacturer or its authorized agents. For repair procedures, follow the instructions outlined under the Limited Warranty.

If this equipment is causing harm to the telephone network, the telephone service provider may temporarily discontinue your telephone service. The telephone service provider is required to notify you before interrupting service. If advance notice is not practical, you will be notified as soon as possible. You will be given the opportunity to correct the problem and the telephone service provider is required to inform you of your right to file a complaint with the FCC. Your telephone service provider may make changes in its facilities, equipment, operation, or procedures that could affect the proper functioning of this product. The telephone service provider is required to notify you if such changes are planned.

If this product is equipped with a corded or cordless handset, it is hearing aid compatible.

If this product has memory dialing locations, you may choose to store emergency telephone numbers (e.g., police, fire, medical) in these locations. If you do store or test emergency numbers, please:

Remain on the line and briefly explain the reason for the call before hanging up.

Perform such activities in off-peak hours, such as early morning or late evening.

Industry Canada

Operation is subject to the following two conditions: (1) this device may not cause harmful interference, and (2) this device must accept any interference, including interference that may cause undesired operation.

The term "IC:" before the certification/registration number only signifies that the Industry Canada technical specifications were met.

The Ringer Equivalence Number (REN) for this terminal equipment is 0.1. The REN is an indication of the maximum number of devices allowed to be connected to a telephone interface. The termination on an interface may consist of any combination of devices subject only to the requirement that the sum of the RENs of all the devices does not exceed five.

This product meets the applicable Industry Canada technical specifications.

FCC part 15

This equipment has been tested and found to comply with the limits for a Class A digital device, pursuant to Part 15 of the FCC Rules. These limits are designed to provide reasonable protection against harmful interference when the equipment is operated in a commercial environment. This equipment generates, uses, and can radiate radio frequency energy and, if not installed and used in accordance with the instruction manual, may cause harmful interference to radio communications. Operation of this equipment in a residential area is likely to cause harmful interference in which case the user will be required to correct the interference at his own expense.

This Class A digital apparatus complies with Canadian ICES-003.

Cet appareil numérique de la classe A est conforme à la norme NMB-003 du Canada.

Warning: Changes or modifications to this equipment not expressly approved by the party responsible for compliance could void the user's authority to operate the equipment.

Caution: To maintain the compliance with the FCC's RF exposure guideline, place the deskset (base unit) at least 20 cm from nearby persons

Limited warranty

The AT&T brand is used under license - any repair, replacement or warranty service, and all questions about this product should be directed to: In the United States of America, visit **www.telephones.att.com** or call **1 (800) 222-3111**. In Canada, call **1 (866) 288-4268**.

1. What does this limited warranty cover?

The manufacturer of this AT&T-branded product warrants to the holder of a valid proof of purchase ("CONSUMER" or "you") that the product and all accessories provided in the sales package ("PRODUCT") are free from defects in material and workmanship, pursuant to the following terms and conditions, when installed and used normally and in accordance with the PRODUCT operating instructions. This limited warranty extends only to the CONSUMER for products purchased and used in the United States of America and Canada.

2. What will be done if the PRODUCT is not free from defects in materials and workmanship during the limited warranty period ("materially defective PRODUCT")?

During the limited warranty period, the manufacturer's authorized service representative will repair or replace at the manufacturer's option, without charge, a materially defective PRODUCT. If the manufacturer repairs the PRODUCT, they may use new or refurbished replacement parts. If the manufacturer chooses to replace the PRODUCT, they may replace it with a new or refurbished PRODUCT of the same or similar design. The manufacturer will retain defective parts, modules, or equipment. Repair or replacement of the PRODUCT, at the manufacturer's option, is your exclusive remedy. The manufacturer will return repaired or replacement products to you in working condition. You should expect the repair or replacement to take approximately 30 days.

3. How long is the limited warranty period?

The limited warranty period for the PRODUCT extends for ONE (1) YEAR from the date of purchase. If the manufacturer repairs or replaces a materially defective PRODUCT under the terms of this limited warranty, this limited warranty also applies to repaired or replacement PRODUCT for a period of either (a) 90 days from the date the repaired or replacement PRODUCT is shipped to you or (b) the time remaining on the original one-year limited warranty; whichever is longer.

4. What is not covered by this limited warranty?

This limited warranty does not cover:

- PRODUCT that has been subjected to misuse, accident, shipping or other physical damage, improper installation, abnormal operation or handling, neglect, inundation, fire, water, or other liquid intrusion; or
- PRODUCT that has been damaged due to repair, alteration, or modification by anyone other than an authorized service representative of the manufacturer; or
- PRODUCT to the extent that the problem experienced is caused by signal conditions, network reliability or cable or antenna systems; or
- PRODUCT to the extent that the problem is caused by use with non-AT&T accessories; or
- PRODUCT whose warranty/quality stickers, PRODUCT serial number plates or electronic serial numbers have been removed, altered or rendered illegible; or
- PRODUCT purchased, used, serviced, or shipped for repair from outside the United States of America or Canada, or used for commercial or institutional purposes (including but not limited to products used for rental purposes); or
- PRODUCT returned without a valid proof of purchase (see item 6 below); or
- Charges for installation or setup, adjustment of customer controls, and installation or repair of systems outside the unit.

Limited warranty

5. How do you get warranty service?

To obtain warranty service in the United States of America, visit

www.telephones.att.com or call **1 (800) 222-3111**. In Canada, call **1 (866) 288-4268**. NOTE: Before calling for service, please review the user's manual; a check of the PRODUCT's controls and features may save you a service call.

Except as provided by applicable law, you assume the risk of loss or damage during transit and transportation and are responsible for delivery or handling charges incurred in the transport of the PRODUCT(s) to the service location. The manufacturer will return repaired or replaced PRODUCT under this limited warranty to you. Transportation, delivery or handling charges are prepaid. The manufacturer assumes no risk for damage or loss of the PRODUCT in transit. If the PRODUCT failure is not covered by this limited warranty, or proof of purchase does not meet the terms of this limited warranty, the manufacturer will notify you and will request that you authorize the cost of repair prior to any further repair activity. You must pay for the cost of repair and return shipping costs for the repair of products that are not covered by this limited warranty.

6. What must you return with the PRODUCT to get warranty service?

You must:

- Return the entire original package and contents including the PRODUCT to the service location along with a description of the malfunction or difficulty; and
- Include a "valid proof of purchase" (sales receipt) identifying the PRODUCT purchased (PRODUCT model) and the date of purchase or receipt; and
- Provide your name, complete and correct mailing address, and telephone number.

7. Other limitations

This warranty is the complete and exclusive agreement between you and the manufacturer of this AT&T branded PRODUCT. It supersedes all other written or oral communications related to this PRODUCT. The manufacturer provides no other warranties for this PRODUCT. The warranty exclusively describes all of the manufacturer's responsibilities regarding the PRODUCT. There are no other express warranties. No one is authorized to make modifications to this limited warranty and you should not rely on any such modification.

State/Provincial Law rights: This warranty gives you specific legal rights, and you may also have other rights which vary from state to state or province to province.

Limitations: Implied warranties, including those of fitness for a particular purpose and merchantability (an unwritten warranty that the PRODUCT is fit for ordinary use) are limited to one year from date of purchase. Some states/provinces do not allow limitations on how long an implied warranty lasts, so the above limitation may not apply to you. In no event shall the manufacturer be liable for any indirect, special, incidental, consequential, or similar damages (including, but not limited to lost profits or revenue, inability to use the PRODUCT or other associated equipment, the cost of substitute equipment, and claims by third parties) resulting from the use of this PRODUCT. Some states/provinces do not allow the exclusion or limitation of incidental or consequential damages, so the above limitation or exclusion may not apply to you.

Please retain your original sales receipt as proof of purchase.

Technical specifications

RF frequency band	1921.536MHz - 1928.448MHz
Channels	5
Operating temperature	32°F - 122°F 0°C - 50°C
Telephone base voltage (AC adapter output)	5.1VDC @1200mA
Ethernet Network Ports	10/100 Mbps RJ-45 Port

Remote access wallet card

Use the wallet card below to help you remember commands to control your answering system from any touch-tone telephone.

Cut along dotted line.



Call your telephone number, then enter your three-digit access code (preset to 111).

Action	Remote command
Play all messages	1*
Play new messages.....	1
Repeat or go back.....	2
Skip the messages.....	3
Play announcement.....	7
End remote access call.....	8(or hang up)

Fold here.

Record memo.....	9
Turn system off or on	0
Delete the message.....	##
Delete all messages.....	#X

Model name: MS2015

Type: DECT 6.0 4-line corded/cordless small business system

© 2010 Advanced American Telephones. All Rights Reserved. AT&T and the AT&T logo are trademarks of AT&T Intellectual Property licensed to Advanced American Telephones, San Antonio, TX 78219. Printed in China.



www.telephones.att.com