



VTech Telecommunications Ltd.

Application
For
Permissive Change Class II

Unlicensed Personal Communication Service Devices
(Base Unit)

FCC ID: EW780-6270-00

Test Report Number: HK08090838-1

Issue Date: October 21, 2008

TL/ ac

- The test report only allows to be revised within the retention period unless further standard or the requirement was noticed.
- This report is for the exclusive use of Intertek's Client and is provided pursuant to the agreement between Intertek and its Client. Intertek's responsibility and liability are limited to the terms and conditions of the agreement. Intertek assumes no liability to any party, other than to the Client in accordance with the agreement, for any loss, expense or damage occasioned by the use of this report. Only the Client is authorized to permit copying or distribution of this report and then only in its entirety. Any use of the Intertek name or one of its marks for the sale or advertisement of the tested material, product or service must first be approved in writing by Intertek. The observations and test results in this report are relevant only to the sample tested. This report by itself does not imply that the material, product, or service is or has ever been under an Intertek certification program.

Intertek Testing Services Hong Kong Ltd.

2/F., Garment Centre, 576 Castle Peak Road, Kowloon, Hong Kong.
Tel: (852) 2173 8888 Fax: (852) 2785 5487 Website: www.hk.intertek-etlsemko.com

LIST OF EXHIBITS

INTRODUCTION

<i>EXHIBIT 1:</i>	Summary of Tests
<i>EXHIBIT 2:</i>	General Description
<i>EXHIBIT 3:</i>	System Test Configuration
<i>EXHIBIT 4:</i>	Measurement Results
<i>EXHIBIT 5:</i>	Equipment Photographs
<i>EXHIBIT 6:</i>	Product Labelling
<i>EXHIBIT 7:</i>	Technical Specifications
<i>EXHIBIT 8:</i>	Instruction Manual
<i>EXHIBIT 9:</i>	Letter of Agency
<i>EXHIBIT 10:</i>	Confidentiality Request

INTERTEK TESTING SERVICES

Table of Contents

1.0 Summary of Test Results	6
2.0 General Description	8
2.1 Product Description	8
2.2 Purpose of Application	8
2.3 Test Methodology	9
2.4 Test Facility	9
3.0 System Test Configuration	11
3.1 Justification	11
3.2 Conducted Emission Test Configuration	12
3.3 Conducted Monitoring and Operational Test Configuration	12
3.4 EUT Exercising Software	12
3.5 Details of EUT and Description of Peripherals.....	13
3.6 Measurement Uncertainty	14
3.7 Equipment Modification.....	14
4.0 Measurement Results	16
4.1 Antenna Requirement.....	16
4.2 Emission Bandwidth	17
4.3 Directional Gain of the Antenna	18
4.4 Peak Transmit Power	19
4.5 Power Spectral Density.....	20
4.6 Unwanted Emission Inside the Sub-Band	21
4.7 Emissions Outside the Sub-Band	22
4.7.1 Radiated Emissions Configuration Photographs	23
4.7.2 Radiated Emissions Data.....	24
4.7.3 Field Strength Calculation	30
4.7.4 Average Factor Calculation and Transmitter ON Time Measurements.....	31
4.8 AC Power Lines Conducted Emissions from Transmitter portion of EUT.....	32
4.8.1 AC Power Lines Conducted Emissions Configuration Photographs	33
4.8.2 AC Power Line Conducted Emissions Data	34
4.9 Radio Frequency Radiation Exposure.....	35
4.10 Frame Period and Jitter	36
4.11 Monitoring Threshold	37
4.11.1 Upper Monitoring Threshold.....	38
4.12 Monitoring Antenna.....	39
5.0 Equipment Photographs	41
6.0 Product Labelling	43
7.0 Technical Specifications	45
8.0 Instruction Manual	47
9.0 Letter of Agency	49
10.0 Confidentiality Request	51

INTERTEK TESTING SERVICES

List of Attached Files

Exhibit Type	File Description	Filename
Test Report	Test Report	report.pdf
Cover Letter	Purpose of Change	product change.pdf
Test Report	Emission Bandwidth and Test Frequency Plots	26bw.pdf
Test Report	Peak Transmit Power Plots	peaktp.pdf
Test Report	Power Spectral Density Plots	psd.pdf
Test Report	Unwanted Emission Inside Sub-Band Plots	inband.pdf
Test Setup Photo	Radiated Emission Test Configuration	config photos.pdf
Test Setup Photo	AC Lines Conducted Emission Test Configuration	
Test Report	AC Lines Conducted Emission Data	conduct.pdf
Test Report	Duty Cycle Calculation and Measurement	dcc.pdf
RF Exposure Info	RF Safety	RF exposure info.pdf
External Photos	External Photo	external photos.pdf
Internal Photos	Internal Photo	internal photos.pdf
ID Label/Location Info	Label Artwork and Location	label.pdf
Block Diagrams	Block Diagram	block.pdf
Schematics	Circuit Diagram	circuit.pdf
User Manual	User Manual	manual.pdf
Cover Letter	Letter of Agency	letter of agency.pdf
Cover Letter	Confidentiality Request	request.pdf

INTERTEK TESTING SERVICES

EXHIBIT 1 SUMMARY OF TEST RESULTS

INTERTEK TESTING SERVICES

1.0 Summary of Test Results

VTech Telecommunications Ltd. - Model: SL80108, SL82x58,
SL82x18, SL87x18

FCC ID: EW780-6270-00

Technical Requirements				
Test Items	FCC Part 15 Section	Test Procedure ANSI C63.17 / ANSI C63.4 *	Results	Details see section
Antenna Requirement	15.317	---	Pass	4.1
Emission Bandwidth	15.323(a)	6.1.3	Pass	4.2
Directional Gain of the Antenna	15.319(e)	4.3.1	Pass	4.3
Peak Transmit Power	15.319(c)	6.1.2	Pass	4.4
Power Spectral Density	15.319(d)	6.1.5	Pass	4.5
Unwanted Emission Inside the Sub-Band	15.323(d)	6.1.6.1	Pass	4.6
Emissions Outside the Sub-Band	15.323(d)	6.1.6.2	Pass	4.7
AC Power Lines Conducted Emissions from Transmitter Portion of EUT	15.315	7 *	Pass	4.8
Radio Frequency Radiation Exposure	15.319(i)	---	Pass	4.9
Frame Period and Jitter	15.323(e)	6.2.3	Pass	4.10
Upper Monitoring Threshold	15.323(c)(5)	7.3.2	Pass	4.11.1
Monitoring Antenna	15.323(c)(8)	4	Pass	4.12

Test Engineer:

Approved By:



Ken Sit
Assistant Manager

Leung Wai Leung, Tommy
Senior Manager

Date: October 21, 2008

Date: October 21, 2008

**EXHIBIT 2
GENERAL DESCRIPTION**

INTERTEK TESTING SERVICES

2.0 General Description

2.1 Product Description

The SL82218 is 1.9GHz Digital Modulation Cordless Phone with Digital Answering Machine - Base Unit. It operates at frequency range of 1921.536MHz to 1928.448MHz with 5 channels (1921.536MHz, 1923.264MHz, 1924.992MHz, 1926.720MHz and 1928.448MHz). The Base Unit is powered by an AC adaptor 100-240VAC to 6VDC 400mA.

The antennas used in base unit and handset are integral, and the test sample is a prototype.

The Model: SL82218 is one of the Model: SL82x18, and the Model: SL82x58 and SL87x18 are the same as the Model: SL82218 in hardware aspect. The suffix, "x", followed by the model number represents number of handsets packed in the package. The Model: SL80108 is a standalone model which selling handset and charger only. Its handset and charger are the same as the Model: SL82218. The difference in model number serves as marketing strategy.

Connection between the base unit and the telephone network is accomplished through the use of USOC RJ11C in the 2-wire loop calling central office line.

2.2 Purpose of Application

The purpose of change is saved as filename: product change.pdf

This is an application for Certification of a PUB - Part 15 Unlicensed PCS Base Station. A verification report has been prepared for the digital device portion. The device is also subject to Part 68 Registration.

INTERTEK TESTING SERVICES

2.3 Test Methodology

The radiated emission measurements for unintentional radiator (if any) and AC power line-conducted emission measurements were performed according to the test procedures specified in ANSI C63.4 (2003). The radiated emission measurements for intentional radiator contained in UPCS device, Listen Before Transmit (LBT) test and antenna conducted measurements were performed according to the test procedures specified in ANSI C63.17 (2006). All radiated measurements were performed in Open Area Test Sites. Preliminary scans were performed in the Open Area Test Sites only to determine worst case modes. All radiated tests were performed at an antenna to EUT distance of 3 meters, unless stated otherwise in the "Justification Section" of this Application. All other measurements were made in accordance with the procedures in 47 CFR Part 2.

2.4 Test Facility

The open area test site and conducted measurement facility used to collect the emission data is located at Garment Centre, 576 Castle Peak Road, Kowloon, Hong Kong. This test facility and site measurement data have been fully placed on file with the FCC.

**EXHIBIT 3
SYSTEM TEST CONFIGURATION**

INTERTEK TESTING SERVICES

3.0 System Test Configuration

3.1 Justification

For emissions testing, the equipment under test (EUT) was setup to transmit continuously in burst mode with pseudo-random data to simplify the measurement methodology. Care was taken to ensure proper power supply voltages during testing. During testing, all cables (if any) were manipulated to produce worst-case emissions. The handset (if any) was powered by a fully charged battery.

For the measurements, the EUT was attached to a plastic stand if necessary and placed on the wooden turntable. If the base unit attached to peripherals, they were connected and operational (as typical as possible).

The signal was maximized through rotation and placement in the three orthogonal axes. The antenna height and polarization were varied during the search for maximum signal level. The antenna height was varied from 1 to 4 meters. Detector function was in peak mode. Radiated emissions were taken at three meters unless the signal level was too low for measurement at that distance. If necessary, a pre-amplifier was used and/or the test was conducted at a closer distance.

The spectrum analyzer resolution bandwidth was approximately 1% of the EUT emission bandwidth, unless otherwise specified.

Radiated emission measurements were performed from the lowest radio frequency signal generated in the device which is greater than 9 kHz to the tenth harmonic of the highest fundamental frequency or to 40 GHz, whichever is lower.

As the base unit has 2 antennas, both have been checked. While conducting the test on one of antennas, another one was being disable its transmission. The data in this report represented the worst-case.

INTERTEK TESTING SERVICES

3.2 Conducted Emission Test Configuration

The setup and equipment setting were made in accordance with ANSI C63.17. The antenna of EUT transmitter was replaced by a coaxial cable. The impedance matching of connection, cable loss and external RF attenuator were taken into account. The EUT was arranged to communicate via a fixed carrier frequency between its transmitter and a companion device. The transmission was configured in burst mode with pseudo-random data as typical as normal operation.

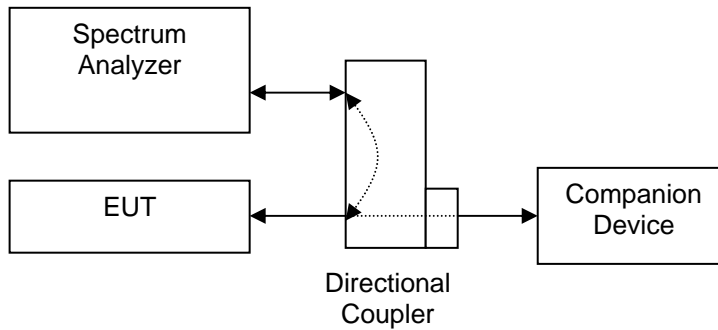

Figure 3.2.1

3.3 Conducted Monitoring and Operational Test Configuration

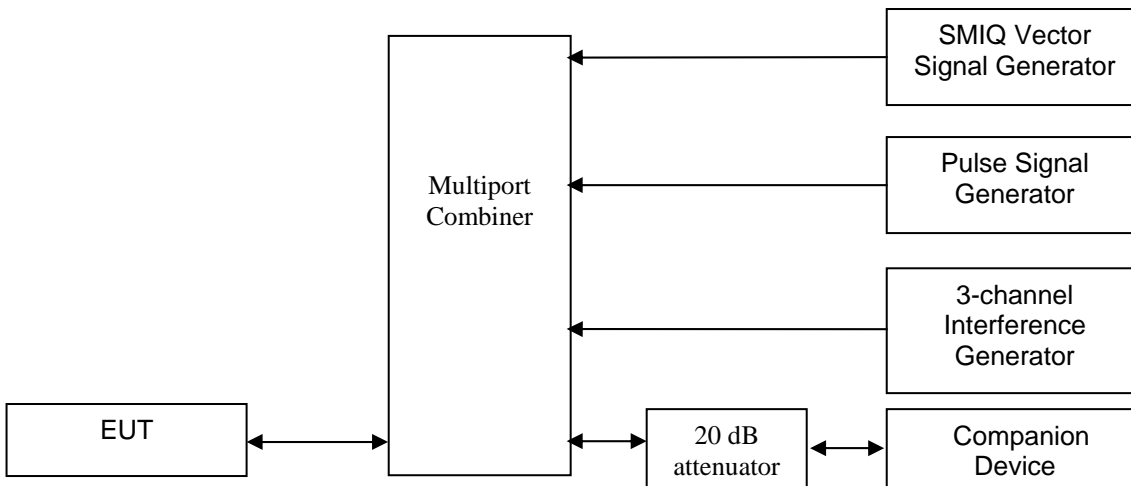

Figure 3.3.1

3.4 EUT Exercising Software

The EUT exercise program (if any) used during radiated and conducted testing was designed to exercise the various system components in a manner similar to a typical use.

INTERTEK TESTING SERVICES

3.5 Details of EUT and Description of Peripherals

Details of EUT:

An AC adaptor and/or a battery (provided with the unit) were used to power the device. Their description are listed below.

- (1) Base Unit: An AC adaptor (100-240VAC to 6VDC 400mA, Model: SSA-5AP-09060040) (Supplied by Client)

Description of Peripherals:

- (1) Handset: A "Ni-MH" Type Rechargeable Battery Pack (2.4V 500mAh, 550mAh, 600mAh) (Supplied by Client)
- (2) Handset, Model: SL82418, FCC ID: EW780-6270-00 (Supplied by Client)
- (3) Telecommunication cable with RJ11C connectors (1m, unshielded), terminated (Supplied by Intertek)
- (4) A headset for telephone use with 1.2m unshielded cable (Supplied by Intertek)

INTERTEK TESTING SERVICES

3.6 Measurement Uncertainty

When determining of the test conclusion, the Measurement Uncertainty test has been considered.

3.7 Equipment Modification

Any modifications installed previous to testing by VTech Telecommunications Ltd. will be incorporated in each production model sold/leased in the United States.

No modifications were installed by Commercial & Electrical Division, Intertek Testing Services Hong Kong Ltd.

All the items listed under section 3.0 of this report are confirmed by:

Confirmed by:

*Leung Wai Leung, Tommy
Senior Manager
Intertek Testing Services Hong Kong Ltd.
Agent for VTech Telecommunications Ltd.*

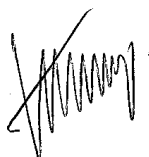

_____ Signature

_____ Date

**EXHIBIT 4
MEASUREMENT RESULTS**

INTERTEK TESTING SERVICES

Company: VTech Telecommunications Ltd. Date of Test: September 30-October 10, 2008
Model: SL82218

4.0 **Measurement Results**

4.1 Antenna Requirement, FCC Rule 15.317:

EUT must meet the antenna requirement of FCC Rule 15.203.

- EUT uses a permanently attached antenna which is considered sufficient to comply with the provisions of this rule. Please refer to Exhibit 5: Internal Photos for more details.

- EUT uses a unique antenna jack or electrical connector which is considered sufficient to comply with the provisions of this rule. Please refer to Exhibit 5: Internal Photos for more details.

INTERTEK TESTING SERVICES

Company: VTech Telecommunications Ltd. Date of Test: September 30-October 10, 2008
Model: SL82218

4.2 Emission Bandwidth, FCC Rule 15.323(a):

Operation shall be contained within the 1920 – 1930 MHz band. The emission bandwidth (*B*) shall be less than 2.5 MHz and greater than 50 kHz.

Measurements are made in accordance with ANSI C63.17 sub-clause 6.1.3. Test setup is shown in section 3.2 Figure 3.2.1.

Test Results:

I. Traffic Carrier

Channel	Channel Frequency (MHz)	Measuring Signal Level	Measured Emission Bandwidth (MHz)	Results
Lowest	1921.536	26 dB down	1.52	Pass
Highest	1928.448	26 dB down	1.51	Pass

II. Dummy Carrier

Channel	Channel Frequency (MHz)	Measuring Signal Level	Measured Emission Bandwidth (MHz)	Results
Lowest	1921.536	26 dB down	1.45	Pass
Highest	1928.448	26 dB down	1.43	Pass

Please refer to the attached plots for more details:

Plot 1A: Lowest Channel 26dB Emission Bandwidth (Traffic Carrier)

Plot 1D: Highest Channel 26dB Emission Bandwidth (Traffic Carrier)

Plot 1G: Lowest Channel 26dB Emission Bandwidth (Dummy Carrier)

Plot 1J: Highest Channel 26dB Emission Bandwidth (Dummy Carrier)

The plots of emission bandwidth and test frequency are saved as filename: 26bw.pdf

INTERTEK TESTING SERVICES

Company: VTech Telecommunications Ltd. Date of Test: September 30-October 10, 2008
Model: SL82218

4.3 Directional Gain of the Antenna, FCC Rule FCC 15.319(e):

The peak transmit power shall be reduced by the amount in dB that the maximum directional gain of the antenna exceeds 3 dBi.

The requirements are made in accordance with ANSI C63.17 sub-clause 4.3.1.

- Manufacturer declares that the directional gain of the antenna is less than or equal to 3dBi. No peak transmit power reduction is required.
- Manufacturer declares that the directional gain of the antenna is greater than 3dBi. The peak transmit power shall be reduced by _____ dB.

INTERTEK TESTING SERVICES

Company: VTech Telecommunications Ltd. Date of Test: September 30-October 10, 2008
Model: SL82218

4.4 Peak Transmit Power, FCC Rule 15.319(c):

The peak transmit power (P_{EUT}) shall not exceed $100\mu W$ multiplied by the square root of the emission bandwidth (B) in Hz or $5 \log_{10} B - 10$ dBm. The peak transmit power shall be reduced by the amount in dB that the maximum directional gain of the antenna exceeds 3 dBi.

Measurements are made in accordance with ANSI C63.17 sub-clause 6.1.2. Test setup is shown in section 3.2 Figure 3.2.1. The cable loss and/or external attenuation are included in OFFSET function of spectrum analyzer.

Calculation of Peak Transmit Power Limit (P_{max}):

$$\begin{aligned} [\times] \quad P_{max} &= 5 \log_{10} B - 10 \text{ dBm} && \text{when } G_A \leq 3 \text{ dBi} \\ [\quad] \quad P_{max} &= 5 \log_{10} B - 10 \text{ dBm} - (G_A - 3 \text{ dBi}) && \text{when } G_A > 3 \text{ dBi} \end{aligned}$$

Where G_A = EUT Antenna Gain: \geq dBi

B = Measured Emission Bandwidth: (26dB down BW) in Hz

Test Results:

I. Traffic Carrier

Channel	Channel Frequency (MHz)	Measured Peak Transmit Power (dBm)	Limit (dBm)	Results
Lowest	1921.536	20.11	20.91	Pass
Highest	1928.448	19.93	20.89	Pass

II. Dummy Carrier

Channel	Channel Frequency (MHz)	Measured Peak Transmit Power (dBm)	Limit (dBm)	Results
Lowest	1921.536	20.11	20.81	Pass
Highest	1928.448	19.90	20.78	Pass

Please refer to the attached plots for more details:

Plot 2A: Lowest Channel Peak Transmit Power (Traffic Carrier)

Plot 2B: Highest Channel Peak Transmit Power (Traffic Carrier)

Plot 2C: Lowest Channel Peak Transmit Power (Dummy Carrier)

Plot 2D: Highest Channel Peak Transmit Power (Dummy Carrier)

The plots of peak transmit power are saved as filename: peaktp.pdf

INTERTEK TESTING SERVICES

Company: VTech Telecommunications Ltd. Date of Test: September 30-October 10, 2008
Model: SL82218

4.5 Power Spectral Density, FCC Rule 15.319(d):

Power spectral density shall not exceed 3 mW (4.8dBm) in any 3 kHz bandwidth as measured with a spectrum analyzer having a resolution bandwidth of 3 kHz.

Measurements are made in accordance with ANSI C63.17 sub-clause 6.1.5. Test setup is shown in section 3.2 Figure 3.2.1.

Test Results:

I. Traffic Carrier

Channel	Channel Frequency (MHz)	Measured Power Spectral Density (dBm/3kHz)	Limit (dBm/3 kHz)	Results
Lowest	1921.536	-10.0	4.8	Pass
Highest	1928.448	-11.4	4.8	Pass

II. Dummy Carrier

Channel	Channel Frequency (MHz)	Measured Power Spectral Density (dBm/3kHz)	Limit (dBm/3 kHz)	Results
Lowest	1921.536	-10.2	4.8	Pass
Highest	1928.448	-18.6	4.8	Pass

Please refer to the attached plots for more details:

Base Unit

Plot 3A: Lowest Channel Power Spectral Density (Traffic Carrier)

Plot 3B: Highest Channel Power Spectral Density (Traffic Carrier)

Plot 3C: Lowest Channel Power Spectral Density (Dummy Carrier)

Plot 3D: Highest Channel Power Spectral Density (Dummy Carrier)

The plots of the power spectral density are saved as filename: psd.pdf

INTERTEK TESTING SERVICES

Company: VTech Telecommunications Ltd. Date of Test: September 30-October 10, 2008
Model: SL82218

4.6 Unwanted Emission Inside the Sub-Band, FCC Rule 15.323(d):

Emissions inside the sub-band must comply with the following emission mask:

1. In the bands between $1B$ and $2B$ measured from the center of the emission bandwidth, emission shall be at least 30 dB below the permitted peak transmit power
2. In the bands between $2B$ and $3B$ measured from the center of the emission bandwidth, emission shall be at least 50 dB below the permitted peak transmit power
3. In the bands between $3B$ and the band edge, emission shall be at least 60 dB below the permitted peak transmit power

Where B = emission bandwidth in Hz

Measurements are made in accordance with ANSI C63.17 sub-clause 6.1.6.1. Test setup is shown in section 3.2 Figure 3.2.1.

Test Results:

I. Traffic Carrier

Channel	Channel Frequency (MHz)	Results
Lowest	1921.536	Pass
Highest	1928.448	Pass

II. Dummy Carrier

Channel	Channel Frequency (MHz)	Results
Lowest	1921.536	Pass
Highest	1928.448	Pass

Please refer to the attached plots for more details:

- Plot 4A: Lowest Channel Unwanted Emission Inside the Sub-Band (Traffic Carrier)
- Plot 4B: Highest Channel Unwanted Emission Inside the Sub-Band (Traffic Carrier)
- Plot 4C: Lowest Channel Unwanted Emission Inside the Sub-Band (Dummy Carrier)
- Plot 4D: Highest Channel Unwanted Emission Inside the Sub-Band (Dummy Carrier)

The plots of the unwanted emission inside the sub-band are saved as filename: inband.pdf

INTERTEK TESTING SERVICES

Company: VTech Telecommunications Ltd. Date of Test: September 30-October 10, 2008
Model: SL82218

4.7 Emissions Outside the Sub-Band, FCC Rule 15.323(d):

Emissions outside the sub-band shall be attenuated below a reference power of 112 mW (20.5 dBm) as follows:

1. 30 dB between the band edge and 1.25 MHz above or below the band;
2. 50 dB between 1.25 and 2.5 MHz above or below the band; and
3. 60 dB at 2.5 MHz or greater above or below the band, or shall meet the requirement of FCC Rule 15.319(g) which shall not exceed the limits of FCC Rule 15.209.

Example: Calculation of Limit for emissions between the band edge and 1.25 MHz (1920.000 – 1918.750 MHz)

The emissions shall not exceed the Limit: 20.5 dBm – 30 dB = -9.5 dBm

Measurements are made in accordance with ANSI C63.17 sub-clause 6.1.6.2. As EUT has non-detachable antenna(s), radiated emissions test method is used for out-of-band emissions tests. Emissions that are directly caused by digital circuits in the transmit path and transmitter portion are measured. Test setup and procedures are described in section 3.2 Figure 3.2.1.

Test Results:

Channel	Carrier Frequency (MHz)	Measured Band (MHz)	Limit (dBm)	Results
Lowest	1921.536	1920.000 - 1918.750	-9.5	Pass
		1918.750 - 1917.500	-29.5	Pass
		0.009 - 1917.500 & 1932.500 – 19300.000	-39.5 / FCC Rule 15.209	Pass
Highest	1928.448	1930.000 - 1931.250	-9.5	Pass
		1931.250 - 1932.500	-29.5	Pass
		0.009 - 1917.500 & 1932.500 - 19300.000	-39.5 / FCC Rule 15.209	Pass

Please refer to the section 4.7.1 to 4.7.4 for more details.

INTERTEK TESTING SERVICES

Company: VTech Telecommunications Ltd. Date of Test: September 30-October 10, 2008
Model: SL82218
Mode: Transmission

4.7.1 Radiated Emissions Configuration Photographs:

Worst Case Radiated Emission
at

3843.072 MHz

The worst case radiated emission configuration photographs are saved as filename:
config photos.pdf

INTERTEK TESTING SERVICES

Company: VTech Telecommunications Ltd. Date of Test: September 30-October 10, 2008
Model: SL82218
Mode: Transmission

4.7.2 Radiated Emissions Data:

Data are included of the worst case configuration (the configuration which resulted in the highest emission levels). A sample calculation, configuration photographs and data tables of the emissions are included. All measurements were performed with peak detection unless otherwise specified.

The data in tables 1-5 list the significant emission frequencies, the limit and the margin of compliance.

Judgement -

Passed by 10.2 dB margin compare with the average limit

TEST ENGINEER:



Signature

Ken Sit, Assistant Manager
Typed/Printed Name

October 21, 2008
Date

INTERTEK TESTING SERVICES

Company: VTech Telecommunications Ltd. Date of Test: September 30-October 10, 2008
Model: SL82218
Mode: Transmission

Table 1

**Radiated Emissions Data
Pursuant To FCC Part 15 Section 15.323 (d) Emissions Requirements**

Lowest Channel:

Polarization	Frequency (MHz)	Measured Power (dBm)	Power Limit (dBm)	Margin (dB)
V	1919.906	-39.0	-9.5	-29.5
V	1918.600	-48.4	-29.5	-18.9
V	1917.402	-50.9	-39.5	-11.4

NOTES:

1. Peak detector is used for the emission measurement.
2. All measurements were made at 3 meters
3. Negative value in the margin column shows emission below limit.

INTERTEK TESTING SERVICES

Company: VTech Telecommunications Ltd. Date of Test: September 30-October 10, 2008
Model: SL82218
Mode: Transmission

Table 2, Base Unit

Radiated Emissions Data Pursuant To FCC Part 15 Section 15.209 Emissions Requirements

Lowest Channel:

Polarization	Frequency (MHz)	Reading (dB μ V)	Pre-Amp Gain (dB)	Antenna Factor (dB)	Net at 3m - Peak (dB μ V/m)	Average Factor (dB)	Calculated at 3m (dB μ V/m)	Average Limit at 3m (dB μ V/m)	Margin (dB)
H	3843.072	59.1	33	33.3	59.4	15.6	43.8	54.0	-10.2
H	5764.608	49.6	33	36.6	53.2	15.6	37.6	54.0	-16.4
H	7686.144	50.5	33	38.9	56.4	15.6	40.8	54.0	-13.2
H	9607.680	48.0	33	40.4	55.4	15.6	39.8	54.0	-14.2
H	11529.216	46.7	33	40.5	54.2	15.6	38.6	54.0	-15.4

Polarization	Frequency (MHz)	Reading (dB μ V)	Pre-Amp Gain (dB)	Antenna Factor (dB)	Net at 3m - Peak (dB μ V/m)	Peak Limit at 3m (dB μ V/m)	Margin (dB)
H	3843.072	59.1	33	33.3	59.4	74.0	-14.6
H	5764.608	49.6	33	36.6	53.2	74.0	-20.8
H	7686.144	50.5	33	38.9	56.4	74.0	-17.6
H	9607.680	48.0	33	40.4	55.4	74.0	-18.6
H	11529.216	46.7	33	40.5	54.2	74.0	-19.8

NOTES:

1. Peak detector is used for the emission measurement over 1000 MHz.
2. All measurements were made at 3 meters.
3. Negative value in the margin column shows emission below limit.

INTERTEK TESTING SERVICES

Company: VTech Telecommunications Ltd. Date of Test: September 30-October 10, 2008
Model: SL82218
Mode: Transmission

Table 3

**Radiated Emissions Data
Pursuant To FCC Part 15 Section 15.323 (d) Emissions Requirements**

Highest Channel:

Polarization	Frequency (MHz)	Measured Power (dBm)	Power Limit (dBm)	Margin (dB)
V	1930.604	-38.4	-9.5	-28.9
V	1931.300	-48.3	-29.5	-18.8
V	1932.602	-51.0	-39.5	-11.5

NOTES:

1. Peak detector is used for the emission measurement.
2. All measurements were made at 3 meters.
3. Negative value in the margin column shows emission below limit.

INTERTEK TESTING SERVICES

Company: VTech Telecommunications Ltd. Date of Test: September 30-October 10, 2008
Model: SL82218
Mode: Transmission

Table 4, Base Unit

Radiated Emissions Data Pursuant To FCC Part 15 Section 15.209 Emissions Requirements

Highest Channel:

Polarization	Frequency (MHz)	Reading (dB μ V)	Pre-Amp Gain (dB)	Antenna Factor (dB)	Net at 3m - Peak (dB μ V/m)	Average Factor (dB)	Calculated at 3m (dB μ V/m)	Average Limit at 3m (dB μ V/m)	Margin (dB)
H	3856.896	58.6	33	33.3	58.9	15.6	43.3	54.0	-10.7
H	5785.344	48.8	33	36.6	52.4	15.6	36.8	54.0	-17.2
H	7713.792	51.0	33	38.9	56.9	15.6	41.3	54.0	-12.7
H	9642.240	46.8	33	40.4	54.2	15.6	38.6	54.0	-15.4
H	11570.688	45.3	33	40.5	52.8	15.6	37.2	54.0	-16.8

Polarization	Frequency (MHz)	Reading (dB μ V)	Pre-Amp Gain (dB)	Antenna Factor (dB)	Net at 3m - Peak (dB μ V/m)	Peak Limit at 3m (dB μ V/m)	Margin (dB)
H	3856.896	58.6	33	33.3	58.9	74.0	-15.1
H	5785.344	48.8	33	36.6	52.4	74.0	-21.6
H	7713.792	51.0	33	38.9	56.9	74.0	-17.1
H	9642.240	46.8	33	40.4	54.2	74.0	-19.8
H	11570.688	45.3	33	40.5	52.8	74.0	-21.2

NOTES:

1. Peak detector is used for the emission measurement over 1000 MHz.
2. All measurements were made at 3 meters.

Negative value in the margin column shows emission below limit.

INTERTEK TESTING SERVICES

Company: VTech Telecommunications Ltd. Date of Test: September 30-October 10, 2008
Model: SL82218
Mode: Talk

Table 5

Radiated Emissions Data
Pursuant To FCC Part 15 Section 15.323 (d) Emissions Requirements

Polarization	Frequency (MHz)	Measured Power (dBm)	Power Limit (dBm)	Margin (dB)
V	41.472	-65.6	-39.5	-26.1
V	55.296	-66.8	-39.5	-27.3
V	69.121	-63.8	-39.5	-24.3
V	82.943	-62.6	-39.5	-23.1
H	110.592	-62.8	-39.5	-23.3
H	124.416	-63.1	-39.5	-23.6
H	165.888	-64.3	-39.5	-24.8
H	193.536	-65.6	-39.5	-26.1
H	248.832	-65.2	-39.5	-25.7

NOTES:

1. Peak detector is used for the emission measurement.
2. All measurements were made at 3 meters.
3. Negative value in the margin column shows emission below limit.

INTERTEK TESTING SERVICES

Company: VTech Telecommunications Ltd. Date of Test: September 30-October 10, 2008
Model: SL82218

4.7.3 Field Strength Calculation

The field strength is calculated by adding the reading on the Spectrum Analyzer to the factors associated with preamplifiers (if any), antennas, cables, pulse desensitization and average factors (when specified limit is in average and measurements are made with peak detectors). A sample calculation is included below.

$$FS = RA + AF + CF - AG + PD + AV$$

Where

- FS = Field Strength in dB μ V/m
- RA = Receiver Amplitude (including preamplifier) in dB μ V
- CF = Cable Attenuation Factor in dB
- AF = Antenna Factor in dB
- AG = Amplifier Gain in dB
- PD = Pulse Desensitization in dB
- AV = Average Factor in -dB

In the radiated emission table which follows, the reading shown on the data table may reflect the preamplifier gain. An example of the calculations, where the reading does not reflect the preamplifier gain, follows:

$$FS = RA + AF + CF - AG + PD + AV$$

Example

Assume a receiver reading of 62.0 dB μ V is obtained. The antenna factor of 7.4 dB and cable factor of 1.6 dB is added. The amplifier gain of 29.0 dB is subtracted. The pulse desensitization factor of the spectrum analyzer is 0.0 dB, and the resultant average factor is -10.0 dB. The net field strength for comparison to the appropriate emission limit is 32.0 dB μ V/m. This value in dB μ V/m is converted to its corresponding level in μ V/m.

RA = 62.0 dB μ V
AF = 7.4 dB
CF = 1.6 dB
AG = 29.0 dB
PD = 0.0 dB
AV = -10 dB

$$FS = 62.0 + 7.4 + 1.6 - 29.0 + 0.0 + (-10.0) = 32.0 \text{ dB}\mu\text{V/m}$$

$$\text{Level in mV/m} = \text{Common Antilogarithm} [(32.0 \text{ dB}\mu\text{V/m})/20] = 39.8 \mu\text{V/m}$$

INTERTEK TESTING SERVICES

Company: VTech Telecommunications Ltd. Date of Test: September 30-October 10, 2008
Model: SL82218

4.7.4 Average Factor Calculation and Transmitter ON Time Measurements, FCC Rule 15.35(b), (c)

Base Unit: (Four handsets, single-slot operation with dummy)

Duty cycle (DC) = Maximum ON time in 10ms/10ms
= (4 x 1 x 0.388ms + 0.103ms)/10ms

Average Factor (AF), dB = $20 \cdot \log(\text{DC})$
= $20 \cdot \log(0.1655)$
= -15.6dB

[x] The EUT antenna output port was connected to the input of the spectrum analyzer. The analyzer center frequency was set to EUT RF channel carrier. The SPAN function on the analyzer was set to ZERO. The transmitter ON time was determined from the resultant time-amplitude display:

Please refer to the attached plots for more details:
Plot B5A: Transmitter ON Time Measurements (Traffic Carrier)
Plot B5B: Transmitter ON Time Measurements (Dummy Carrier)

The plots of Transmitter ON Time Measurements are saved as filename:
dcc.pdf

[] Please refer to the technical description that are provided by Applicant.

[] Not applicable - No average factor is required.

INTERTEK TESTING SERVICES

Company: VTech Telecommunications Ltd. Date of Test: September 30-October 10, 2008
Model: SL82218

4.8 AC Power Lines Conducted Emissions from Transmitter portion of EUT, FCC Rule 15.315:

The AC power lines conducted emission shall not exceed the limits of FCC Rule 15.207.

Measurements are made in accordance with ANSI C63.4 sub-clause 7. Emissions that are directly caused by digital circuits in the transmit path and transmitter portion are measured.

- Not applicable – EUT is only powered by battery for operation.
- EUT connects to AC power lines. Emission Data are listed in following pages. Please refer to the section 4.8.1 to 4.8.2 for more details.

INTERTEK TESTING SERVICES

Company: VTech Telecommunications Ltd. Date of Test: September 30-October 10, 2008
Model: SL82218
Mode: Talk

4.8.1 AC Power Lines Conducted Emissions Configuration Photographs:

Worst Case AC Power Line Conducted Emission
at

1.32000 MHz

The worst case AC power Line conducted emission configuration photographs are saved
as filename: config photos.pdf

INTERTEK TESTING SERVICES

Company: VTech Telecommunications Ltd. Date of Test: September 30-October 10, 2008
Model: SL82218
Mode: Talk

4.8.2 AC Power Line Conducted Emissions Data:

The data on the following pages list the significant emission frequencies, the limit, and the margin of compliance.

Judgment: Passed by 16.3 dB margin

The worst case AC power line conducted emission data are saved as filename:
conduct.pdf

TEST ENGINEER:



Signature

Ken Sit, Assistant Manager
Typed/Printed Name

October 21, 2008
Date

INTERTEK TESTING SERVICES

Company: VTech Telecommunications Ltd. Date of Test: September 30-October 10, 2008
Model: SL82218

4.9 Radio Frequency Radiation Exposure, FCC Rule 15.319(i):

EUT is subject to the radio frequency exposure requirements specified in FCC Rule §§ 1.1307(b), 2.1091 and 2.1093. It shall be considered to operate in a “general population / uncontrolled” environment.

- EUT was evaluated for Specific Absorption Rate (SAR) evaluation compliance according to OET Bulletin 65, Supplement C (Edition 01-01). It is in compliance with the SAR evaluation requirements. The caution statement is saved as filename: RF exposure info.pdf. A SAR test report was submitted at same time.
- EUT was evaluated for Maximum Permissible Exposure (MPE) evaluation compliance according to OET Bulletin 65, Supplement C (Edition 01-01). The evaluation calculation results are saved as filename: RF exposure info.pdf.

INTERTEK TESTING SERVICES

Company: VTech Telecommunications Ltd. Date of Test: September 30-October 10, 2008
Model: SL82218

4.10 Frame Period and Jitter, FCC Rule 15.323(e):

The frame period (a set of consecutive time slots in which the position of each time slot can be identified by reference to a synchronizing source) of EUT operating in these sub-bands shall be 20 ms or 10 ms/X where X is a positive whole number.

The jitter (time-related, abrupt, spurious variations in the duration of the frame interval) introduced at the two ends of such a communication link shall not exceed 25 μ s for any two consecutive transmissions. Transmissions shall be continuous in every time and spectrum window during the frame period defined for EUT.

Measurements are made in accordance with ANSI C63.17 sub-clause 6.2.3. Test setup is shown in section 3.2 Figure 3.2.1. A spectrum analyzer measures the time duration between the rising edges of two consecutive frames. The measurements are taken over 100,000 frames. These measurement values are used to compute mean value and the difference between any two consecutive frame periods. The mean value is the frame period.

Test Results:

I. Jitter

Measured Maximum Jitter (μ s)	Limit (μ s)	Results
-0.1856	± 25	Pass

INTERTEK TESTING SERVICES

Company: VTech Telecommunications Ltd. Date of Test: September 30-October 10, 2008
Model: SL82218

4.11 Monitoring Threshold:

Monitoring threshold can be relaxed according to FCC Rule 15.323(c)(9). EUT that has a power output lower than the maximum permitted under FCC Rule 15.319(c) may increase their monitoring detection threshold by one decibel for each one decibel that the transmitter power is below the maximum permitted.

Calculation of Monitoring Threshold Limit:

$$\begin{aligned} \text{Monitoring Threshold } (T) &\leq -174 + 10 \log_{10} B + M + P_{\max} - P_{\text{EUT}} \text{ dBm} \\ &\leq 15 \log_{10} B - 184 + M - P_{\text{EUT}} \text{ dBm} \end{aligned}$$

Where B = Measured Occupied Bandwidth: 1.45 x10⁶ Hz
 M = 50 dB for Upper Monitoring Threshold (T_U)
 P_{\max} = 5 log₁₀ B – 10 dBm
 P_{EUT} = Measured Peak Transmit Power: 20.11dBm

Calculated Monitoring Threshold Limits:

Upper Monitoring Threshold ($T_U + U_M$) in dBm	-55.7
---	-------

INTERTEK TESTING SERVICES

Company: VTech Telecommunications Ltd. Date of Test: September 30-October 10, 2008
Model: SL82218

4.11.1 Upper Monitoring Threshold, FCC Rule 15.323(c)(5):

Measurements are made in accordance with ANSI C63.17 sub-clause 7.3.2(b). Test setup is shown in section 3.3 Figure 3.3.1. The test is performed on the carrier closest to center of the band. RF signal generators apply uniform CW interference on all EUT carriers each at level $T_U + U_M + 10$ dB. Then, the interference level is reduced uniformly on all carriers until the EUT can transmit. The interference level shall be lower than or equal to the threshold limit.

Test Results:

Measured Maximum Interference Level (dBm)	Upper Monitoring Threshold Limit (dBm) ($T_U + U_M$)	Results
-57.5	-55.7	Pass

INTERTEK TESTING SERVICES

Company: VTech Telecommunications Ltd. Date of Test: September 30-October 10, 2008
Model: SL82218

4.12 Monitoring Antenna, FCC Rule 15.323(c)(8):

The monitoring system shall use the same antenna used for transmission, or an antenna that yields equivalent reception at that location.

- EUT uses the same antenna used for transmission and monitoring that is in compliance meet above provision.
- EUT uses difference antenna used for transmission and monitoring. It must be verified that the monitoring antenna provides coverage equivalent to that of the transmitting antenna. Measurements are made in accordance with ANSI C63.17 sub-clause 4.

INTERTEK TESTING SERVICES

**EXHIBIT 5
EQUIPMENT PHOTOGRAPHS**

INTERTEK TESTING SERVICES

5.0 Equipment Photographs

The photographs are saved as filename: external photos.pdf & internal photos.pdf

INTERTEK TESTING SERVICES

**EXHIBIT 6
PRODUCT LABELLING**

INTERTEK TESTING SERVICES

6.0 Product Labelling

The FCC ID label artwork and its location are saved as filename: label.pdf

INTERTEK TESTING SERVICES

EXHIBIT 7 TECHNICAL SPECIFICATIONS

INTERTEK TESTING SERVICES

7.0 Technical Specifications

The block diagram and circuit diagram are saved as filename: block.pdf and circuit.pdf respectively.

INTERTEK TESTING SERVICES

EXHIBIT 8 INSTRUCTION MANUAL

INTERTEK TESTING SERVICES

8.0 Instruction Manual

A preliminary copy of the Instruction Manual is saved as filename: manual.pdf

The required FCC Information to the User is stated on the Instruction Manual.

This manual will be provided to the end-user with each unit sold/leased in the United States.

INTERTEK TESTING SERVICES

**EXHIBIT 9
LETTER OF AGENCY**

INTERTEK TESTING SERVICES

9.0 Letter of Agency

A copy of the Letter of Agency is saved as filename: letter of agency.pdf

INTERTEK TESTING SERVICES

**EXHIBIT 10
CONFIDENTIALITY REQUEST**

INTERTEK TESTING SERVICES

10.0 Confidentiality Request

A copy of the Confidentiality Request is saved as filename: request.pdf