

VTech Telecommunications Ltd.

Application
For
Permissive Change Class II

Unlicensed Personal Communication Service Devices
(Base Unit)

FCC ID: EW780-6044-01

Test Report Number: 06251981

Issue Date: December 30, 2006

KL/ Ann Choy

- The test results reported in this test report shall refer only to the sample actually tested and shall not refer or be deemed to refer to bulk from which such a sample may be said to have been obtained.
- This report shall not be reproduced except in full without prior authorization from Intertek Testing Services Hong Kong Limited.
- For Terms And Conditions of the services, it can be provided upon request.
- The evaluation data of the report will be kept for 3 years from the date of issuance.

Intertek Testing Services Hong Kong Ltd.

2/F., Garment Centre, 576 Castle Peak Road, Kowloon, Hong Kong.
Tel: (852) 2173 8888 Fax: (852) 2785 5487 Website: www.hk.intertek-etlsemko.com

LIST OF EXHIBITS

INTRODUCTION

- EXHIBIT 1:* Summary of Tests
- EXHIBIT 2:* General Description
- EXHIBIT 3:* System Test Configuration
- EXHIBIT 4:* Measurement Results
- EXHIBIT 5:* Equipment Photographs
- EXHIBIT 6:* Product Labelling
- EXHIBIT 7:* Technical Specifications
- EXHIBIT 8:* Instruction Manual
- EXHIBIT 9:* UTAM Affidavit
- EXHIBIT 10:* Confidentiality Request

INTERTEK TESTING SERVICES

Table of Contents

1.0 Summary of Test Results	6
2.0 General Description	8
2.1 Product Description	8
2.2 Purpose of Application	8
2.3 Test Methodology	9
2.4 Test Facility	9
3.0 System Test Configuration	11
3.1 Justification.....	11
3.2 Conducted Emission Test Configuration	12
3.3 Conducted Monitoring and Operational Test Configuration	12
3.4 EUT Exercising Software	12
3.5 Support Equipment List and Description	13
3.6 Measurement Uncertainty.....	14
3.7 Equipment Modification.....	14
4.0 Measurement Results	16
4.1 Antenna Requirement.....	16
4.2 Digital Modulation Techniques	16
4.3 Emission Bandwidth	17
4.3 Emission Bandwidth	18
4.4 Directional Gain of the Antenna	19
4.5 Peak Transmit Power	20
4.5 Peak Transmit Power	21
4.6 Unwanted Emission Inside the Sub-Band	22
4.7 Emissions Outside the Sub-Band	23
4.7.1 Radiated Emissions Configuration Photographs	24
4.7.2 Radiated Emissions Data.....	25
4.7.3 Field Strength Calculation	32
4.7.4 Average Factor Calculation and Transmitter ON Time Measurements	33
4.8 AC Power Lines Conducted Emissions from Transmitter portion of EUT.....	34
4.8.1 AC Power Lines Conducted Emissions Configuration Photographs	35
4.8.2 AC Power Line Conducted Emissions Data	36
4.9 Radiated Emissions from Computing Device Peripheral Portion of EUT	37
4.10 AC Power Lines Conducted Emissions from Computing Device Peripheral Portion of EUT	38
4.11 Radio Frequency Radiation Exposure.....	39
4.12 Monitoring Antenna.....	40
5.0 Equipment Photographs	42
6.0 Product Labelling	44
7.0 Technical Specifications	46
8.0 Instruction Manual	48
9.0 UTAM Affidavit	50
10.0 Confidentiality Request	52

INTERTEK TESTING SERVICES

List of Attached Files

Exhibit Type	File Description	Filename
Operation Description	Technical Description	descri.pdf
Operation Description	Purpose of Change	product change.pdf
Test Report	Test Report	report.pdf
Test Report	Emission Bandwidth and Test Frequency Plots	26bw.pdf
Test Report	Peak Transmit Power Plots	peaktp.pdf
Test Report	Unwanted Emission Inside Sub-Band Plots	inband.pdf
Test Report	AC Lines Conducted Emission Data	conduct.pdf
Test Setup Photo	Radiated Emission Test Configuration	config photos.doc
Test Setup Photo	AC Lines Conducted Emission Test Configuration	
RF Exposure Info	RF Safety	RF exposure info.pdf
External Photos	External Photo	external photos.doc
Internal Photos	Internal Photo	internal photos.doc
ID Label/Location Info	Label Artwork and Location	label.pdf
Block Diagrams	Block Diagram	block.pdf
Schematics	Circuit Diagram	circuit.pdf
User Manual	User Manual	manual.pdf
Cover Letter	UTAM affidavit	utam.pdf
Cover Letter	Confidentiality Request	request.pdf

**EXHIBIT 1
SUMMARY OF TEST RESULTS**

INTERTEK TESTING SERVICES

1.0 Summary of Test Results

VTech Telecommunications Ltd. - Model: 6041, 6042,
6031, 6032,
6043, 6052, 6053

FCC ID: EW780-6044-01

Technical Requirements				
Test Items	FCC Part 15 Section	Test Procedure ANSI C63.17 / ANSI C63.4 *	Results	Details see section
Antenna Requirement	15.317	---	Pass	4.1
Digital Modulation Techniques	15.319(b)	6.1.4	Pass	4.2
Emission Bandwidth	15.323(a)	6.1.3	Pass	4.3
Directional Gain of the Antenna	15.319(e)	4.3.1	Pass	4.4
Peak Transmit Power	15.319(c)	6.1.2	Pass	4.5
AC Power Lines Conducted Emissions from Transmitter Portion of EUT	15.315	7 *	Pass	4.8
Radiated Emissions from Computing Device Peripheral Portion of EUT	15.109(a)	8 *	NA	4.9
AC Power Lines Conducted Emissions from Computing Device Peripheral Portion of EUT	15.107(a)	7 *	NA	4.10
Radio Frequency Radiation Exposure	15.319(i)	---	Pass	4.11
Unwanted Emission Inside the Sub-Band	15.323(d)	6.1.6.1	Pass	4.6
Emissions Outside the Sub-Band	15.323(d)	6.1.6.2	Pass	4.7
Monitoring Antenna	15.323(c)(8)	4	Pass	4.16

Test Engineer:



Felix Ng
Lead Engineer

Date: December 30, 2006

Approved By:

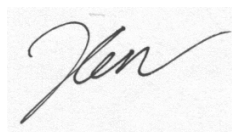

Lam Chun Cheong, Kenneth
Senior Lead Engineer

Date: December 30, 2006

**EXHIBIT 2
GENERAL DESCRIPTION**

INTERTEK TESTING SERVICES

2.0 General Description

2.1 Product Description

The 6041 is 1.9GHz Digital Modulation Cordless Phone with Caller ID and Speakerphone - Base Unit, while 6042 is 1.9GHz Digital Modulation Cordless Phone with Caller ID, Speakerphone and Digital Answering machine - Base Unit. They operate at frequency range of 1921.536MHz to 1928.448MHz with 5 channels. They are capable of either tone or pulse dialing. Their internal power supply's isolation are accomplished through a power transformer having an adequate dielectric rating. Their circuit wiring are consistent under the requirement of part 68.

The handset unit consists of a keypad with twelve standard keys (0,...9,*,#), seven function keys (Clear, Menu/Select, Intercom, Speakerphone, Redial/Pause, Directory/Volume Up/, Caller ID/Volume Down. A Talk key with flash function is provided to control pick and release telephone line in a toggle base.

Each base unit for 6041 and 6042 has a page key, which is used to communicate with handset unit. 6042 additional equips digital answering machine operating buttons.

The antennas used in base unit and handset are integral, and the test sample is a prototype.

The circuit description and digital modulation techniques description are saved as filename: descri.pdf

2.2 Purpose of Application

The purpose of change is saved as filename: product change.pdf

For Model: 6041, the RF module and algorithm are the same as the previously granted Model: DE6010. Enclosure, PCB layout and antenna are changed.

For Model: 6042, the changes are the same as 6041, yet digital answering machine feature is added and hence the enclosure and PCB layout for Model: 6042 are different from Model: 6041. The RF module and algorithm are the same as Model 6041.

The base unit of Model: 6031 is the same as the Model: 6041 in hardware aspect, whereas the base unit of Model: 6032, 6043, 6052, 6053 are the same as the Model: 6042 in hardware aspect respectively. All of the above models share with identical handset, and charger (if any). Differences between models are the number of handset, and charger (if any) in sales package, and model number which serve as marketing strategy.

This is an application for Certification of a PUB - Part 15 Unlicensed PCS Base Station. The FCC ID of the associated handset is EW780-6044-00 and has been filed at the same time as this application. A verification report has been prepared for the digital portion. The device is also subject to Part 68 Registration.

INTERTEK TESTING SERVICES

2.3 Test Methodology

The radiated emission measurements for unintentional radiator and AC power line-conducted emission measurements were performed according to the test procedures specified in ANSI C63.4 (2003). The radiated emission measurements for intentional radiator contained in UPCS device, and antenna conducted measurements were performed according to the test procedures specified in Revision Draft ANSI C63.17 (2006). All radiated measurements were performed in Open Area Test Sites. Preliminary scans were performed in the Open Area Test Sites only to determine worst case modes. All radiated tests were performed at an antenna to EUT distance of 3 meters, unless stated otherwise in the "Justification Section" of this Application. All other measurements were made in accordance with the procedures in 47 CFR Part 2.

2.4 Test Facility

The open area test site and conducted measurement facility used to collect the emission data is located at Garment Centre, 576 Castle Peak Road, Kowloon, Hong Kong. This test facility and site measurement data have been fully placed on file with the FCC.

**EXHIBIT 3
SYSTEM TEST CONFIGURATION**

INTERTEK TESTING SERVICES

3.0 System Test Configuration

3.1 Justification

For emissions testing, the equipment under test (EUT) was setup to transmit continuously in burst mode with pseudo-random data to simplify the measurement methodology. Care was taken to ensure proper power supply voltages during testing. During testing, all cables were manipulated to produce worst-case emissions. The handset was powered by a fully charged battery.

For the measurements, the EUT was attached to a plastic stand if necessary and placed on the wooden turntable. If the base unit attached to peripherals, they were connected and operational (as typical as possible).

The signal was maximized through rotation and placement in the three orthogonal axes. The antenna height and polarization were varied during the search for maximum signal level. The antenna height was varied from 1 to 4 meters. Detector function was in peak mode. Radiated emissions are taken at three meters unless the signal level was too low for measurement at that distance. If necessary, a pre-amplifier was used and/or the test was conducted at a closer distance.

All readings were extrapolated back to the equivalent three meters reading using inverse scaling with distance. The spectrum analyzer resolution bandwidth was approximately 1% of the EUT emission bandwidth, unless otherwise specified.

Radiated emission measurements were performed from the lowest radio frequency signal generated in the device which is greater than 9 kHz to the tenth harmonic of the highest fundamental frequency or to 40 GHz, whichever is lower.

As the base unit has 2 antennas, both have been checked. While conducting the test on one of antennas, another one was being disable its transmission. The data in this report represented the worst-case.

INTERTEK TESTING SERVICES

3.2 Conducted Emission Test Configuration

The setup and equipment setting were made in accordance with ANSI C63.17. The antenna of EUT transmitter was replaced by a coaxial cable. The impedance matching of connection, cable loss and external RF attenuator are taken into account. The EUT was arranged to communicate via a fixed carrier frequency between its transmitter and a companion device. The transmission was configured in burst mode with pseudo-random data as typical as normal operation.

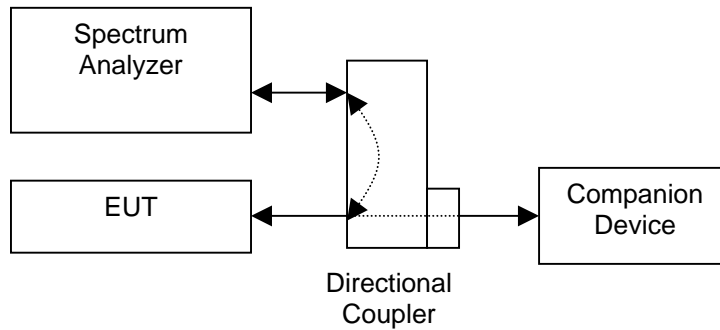

Figure 3.2.1

3.3 Conducted Monitoring and Operational Test Configuration

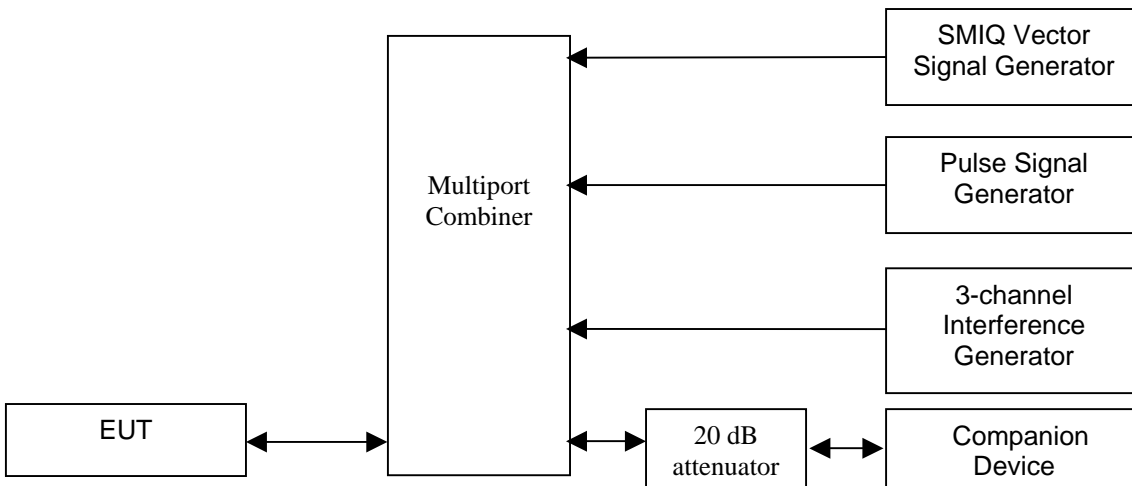

Figure 3.3.1

3.4 EUT Exercising Software

The EUT exercise program used during radiated and conducted testing was designed to exercise the various system components in a manner similar to a typical use.

INTERTEK TESTING SERVICES

3.5 Support Equipment List and Description

The FCC ID's for all equipment, plus descriptions of all cables used in the tested system are:

HARDWARE:

The unit was operated standalone. An AC adaptor and a battery (provided with the unit) were used to power the device. Their descriptions are listed below.

- (1) For Model 6041: An AC adaptor (117VAC to 6VDC 300mA, Model: UD0603) (Supplied by Client)
- (2) For Model 6042: An AC adaptor (117VAC to 6VDC 600mA, Model: UD060060B) (Supplied by Client)
- (3) Handset: A "Ni-MH" Type Rechargeable Battery (2.4V 600mAh) (Supplied by Client)

CABLES:

- (1) Telecommunication cable with RJ11C connectors (1m, unshielded), terminated (Supplied by Intertek)

OTHERS:

- (1) Handset, Model: 6041, FCC ID: EW780-6044-00 (Supplied by Client)

INTERTEK TESTING SERVICES

3.6 Measurement Uncertainty

When determining of the test conclusion, the Measurement Uncertainty test has been considered.

Uncertainty and Compliance - Unless the standard specifically states that measured values are to be extended by the measurement uncertainty in determining compliance, all compliance determinations are based on the actual measured value.

3.7 Equipment Modification

Any modifications installed previous to testing by VTech Telecommunications Ltd. will be incorporated in each production model sold/leased in the United States.

No modifications were installed by ETL Division, Intertek Testing Services Hong Kong Ltd.

All the items listed under section 3.0 of this report are confirmed by:

Confirmed by:

*Lam Chun Cheong, Kenneth
Senior Lead Engineer
Intertek Testing Services Hong Kong Ltd.
Agent for VTech Telecommunications Ltd.*



Signature

December 30, 2006

Date

**EXHIBIT 4
MEASUREMENT RESULTS**

INTERTEK TESTING SERVICES

Company: VTech Telecommunications Ltd.
Model: 6041, 6042

Date of Test: November 11-30, 2006

4.0 **Measurement Results**

4.1 Antenna Requirement, FCC Rule 15.317:

EUT must meet the antenna requirement of FCC Rule 15.203.

EUT uses a permanently attached antenna which is considered sufficient to comply with the provisions of this rule. Please refer to Exhibit 5: Internal Photos for more details.

EUT uses a unique antenna jack or electrical connector which is considered sufficient to comply with the provisions of this rule. Please refer to Exhibit 5: Internal Photos for more details.

4.2 Digital Modulation Techniques, FCC Rule 15.319(b):

All transmissions must use only digital modulation techniques.

The requirements are made in accordance with ANSI C63.17 sub-clause 6.1.4.

Attestation:

Please refer to the technical description in section 2.2 or relevant DECT standards for more details.

INTERTEK TESTING SERVICES

Company: VTech Telecommunications Ltd.
Model: 6041

Date of Test: November 11-30, 2006

4.3 Emission Bandwidth, FCC Rule 15.323(a):

Operation shall be contained within the 1920 – 1930 MHz band. The emission bandwidth (*B*) shall be less than 2.5 MHz and greater than 50 kHz.

Measurements are made in accordance with ANSI C63.17 sub-clause 6.1.3. Test setup is shown in section 3.2 Figure 3.2.1.

Test Results:

I. Traffic Carrier

Channel	Channel Frequency (MHz)	Measuring Signal Level	Measured Emission Bandwidth (MHz)	Results
Lowest	1921.536	26 dB down	2.38	Pass
Highest	1928.448	26 dB down	2.39	Pass

II. Dummy Carrier

Channel	Channel Frequency (MHz)	Measuring Signal Level	Measured Emission Bandwidth (MHz)	Results
Lowest	1921.536	26 dB down	2.38	Pass
Highest	1928.448	26 dB down	2.39	Pass

Please refer to the attached plots for more details:

- Plot 1A1: Lowest Channel 26dB Emission Bandwidth (Traffic Carrier)
- Plot 1D1: Highest Channel 26dB Emission Bandwidth (Traffic Carrier)
- Plot 1G1: Lowest Channel 26dB Emission Bandwidth (Dummy Carrier)
- Plot 1J1: Highest Channel 26dB Emission Bandwidth (Dummy Carrier)

INTERTEK TESTING SERVICES

Company: VTech Telecommunications Ltd.
Model: 6042

Date of Test: November 11-30, 2006

4.3 Emission Bandwidth, FCC Rule 15.323(a): - Continue

Operation shall be contained within the 1920 – 1930 MHz band. The emission bandwidth (B) shall be less than 2.5 MHz and greater than 50 kHz.

Measurements are made in accordance with ANSI C63.17 sub-clause 6.1.3. Test setup is shown in section 3.2 Figure 3.2.1.

Test Results:

I. Traffic Carrier

Channel	Channel Frequency (MHz)	Measuring Signal Level	Measured Emission Bandwidth (MHz)	Results
Lowest	1921.536	26 dB down	2.38	Pass
Highest	1928.448	26 dB down	2.39	Pass

II. Dummy Carrier

Channel	Channel Frequency (MHz)	Measuring Signal Level	Measured Emission Bandwidth (MHz)	Results
Lowest	1921.536	26 dB down	2.38	Pass
Highest	1928.448	26 dB down	2.39	Pass

Please refer to the attached plots for more details:

- Plot 1A2: Lowest Channel 26dB Emission Bandwidth (Traffic Carrier)
- Plot 1D2: Highest Channel 26dB Emission Bandwidth (Traffic Carrier)
- Plot 1G2: Lowest Channel 26dB Emission Bandwidth (Dummy Carrier)
- Plot 1J2: Highest Channel 26dB Emission Bandwidth (Dummy Carrier)

The plots of emission bandwidth and test frequency are saved as filename: 26bw.pdf

INTERTEK TESTING SERVICES

Company: VTech Telecommunications Ltd.
Model: 6041, 6042

Date of Test: November 11-30, 2006

4.4 Directional Gain of the Antenna, FCC Rule FCC 15.319(e):

The peak transmit power shall be reduced by the amount in dB that the maximum directional gain of the antenna exceeds 3 dBi.

The requirements are made in accordance with ANSI C63.17 sub-clause 4.3.1.

- Manufacturer declares that the directional gain of the antenna is less than or equal to 3dBi. No peak transmit power reduction is required.
- Manufacturer declares that the directional gain of the antenna is greater than 3dBi. The peak transmit power shall be reduced by _____ dB.

INTERTEK TESTING SERVICES

Company: VTech Telecommunications Ltd.
Model: 6041

Date of Test: November 11-30, 2006

4.5 Peak Transmit Power, FCC Rule 15.319(c):

The peak transmit power (P_{EUT}) shall not exceed $100\mu W$ multiplied by the square root of the emission bandwidth (B) in Hz or $5 \log_{10} B - 10$ dBm. The peak transmit power shall be reduced by the amount in dB that the maximum directional gain of the antenna exceeds 3 dBi.

Measurements are made in accordance with ANSI C63.17 sub-clause 6.1.2. Test setup is shown in section 3.2 Figure 3.2.1. The cable loss and/or external attenuation are included in OFFSET function of spectrum analyzer.

Calculation of Peak Transmit Power Limit (P_{max}):

$$\begin{aligned} [\times] \quad P_{max} &= 5 \log_{10} B - 10 \text{ dBm} && \text{when } G_A \leq 3 \text{ dBi} \\ [\quad] \quad P_{max} &= 5 \log_{10} B - 10 \text{ dBm} - (G_A - 3 \text{ dBi}) && \text{when } G_A > 3 \text{ dBi} \end{aligned}$$

Where G_A = EUT Antenna Gain: 0 dBi

B = Measured Emission Bandwidth: (26dB down BW) in Hz

Test Results:

I. Traffic Carrier

Channel	Channel Frequency (MHz)	Measured Peak Transmit Power (dBm)	Limit (dBm)	Results
Lowest	1921.536	19.92	21.88	Pass
Highest	1928.448	19.89	21.89	Pass

II. Dummy Carrier

Channel	Channel Frequency (MHz)	Measured Peak Transmit Power (dBm)	Limit (dBm)	Results
Lowest	1921.536	19.92	21.88	Pass
Highest	1928.448	19.86	21.89	Pass

Please refer to the attached plots for more details:

Plot 2A1: Lowest Channel Peak Transmit Power (Traffic Carrier)

Plot 2B1: Highest Channel Peak Transmit Power (Traffic Carrier)

Plot 2C1: Lowest Channel Peak Transmit Power (Dummy Carrier)

Plot 2D1: Highest Channel Peak Transmit Power (Dummy Carrier)

INTERTEK TESTING SERVICES

Company: VTech Telecommunications Ltd.
Model: 6042

Date of Test: November 11-30, 2006

4.5 Peak Transmit Power, FCC Rule 15.319(c): - Continue

The peak transmit power (P_{EUT}) shall not exceed $100\mu W$ multiplied by the square root of the emission bandwidth (B) in Hz or $5 \log_{10} B - 10$ dBm. The peak transmit power shall be reduced by the amount in dB that the maximum directional gain of the antenna exceeds 3 dBi.

Measurements are made in accordance with ANSI C63.17 sub-clause 6.1.2. Test setup is shown in section 3.2 Figure 3.2.1. The cable loss and/or external attenuation are included in OFFSET function of spectrum analyzer.

Calculation of Peak Transmit Power Limit (P_{max}):

$$\begin{aligned} [\times] \quad P_{max} &= 5 \log_{10} B - 10 \text{ dBm} && \text{when } G_A \leq 3\text{dBi} \\ [\quad] \quad P_{max} &= 5 \log_{10} B - 10 \text{ dBm} - (G_A - 3\text{dBi}) && \text{when } G_A > 3\text{dBi} \end{aligned}$$

Where G_A = EUT Antenna Gain: 0 dBi

B = Measured Emission Bandwidth: (26dB down BW) in Hz

Test Results:

II. Traffic Carrier

Channel	Channel Frequency (MHz)	Measured Peak Transmit Power (dBm)	Limit (dBm)	Results
Lowest	1921.536	20.11	21.88	Pass
Highest	1928.448	20.05	21.89	Pass

II. Dummy Carrier

Channel	Channel Frequency (MHz)	Measured Peak Transmit Power (dBm)	Limit (dBm)	Results
Lowest	1921.536	20.08	21.88	Pass
Highest	1928.448	20.02	21.89	Pass

Please refer to the attached plots for more details:

Plot 2A2: Lowest Channel Peak Transmit Power (Traffic Carrier)

Plot 2B2: Highest Channel Peak Transmit Power (Traffic Carrier)

Plot 2C2: Lowest Channel Peak Transmit Power (Dummy Carrier)

Plot 2D2: Highest Channel Peak Transmit Power (Dummy Carrier)

The plots of peak transmit power are saved as filename: peaktp.pdf

INTERTEK TESTING SERVICES

Company: VTech Telecommunications Ltd.
Model: 6041, 6042

Date of Test: November 11-30, 2006

4.6 Unwanted Emission Inside the Sub-Band, FCC Rule 15.323(d):

Emissions inside the sub-band must comply with the following emission mask:

1. In the bands between $1B$ and $2B$ measured from the center of the emission bandwidth, emission shall be at least 30 dB below the permitted peak transmit power; i.e. -9.5 dBm
2. In the bands between $2B$ and $3B$ measured from the center of the emission bandwidth, emission shall be at least 50 dB below the permitted peak transmit power; i.e. -29.5 dBm
3. In the bands between $3B$ and the band edge, emission shall be at least 60 dB below the permitted peak transmit power. i.e. -39.5 dBm

Where B = emission bandwidth in Hz

Measurements are made in accordance with ANSI C63.17 sub-clause 6.1.6.1. Test setup is shown in section 3.2 Figure 3.2.1.

Test Results:

I. Traffic Carrier

Channel	Channel Frequency (MHz)	Results
Lowest	1921.536	Pass
Highest	1928.448	Pass

II. Dummy Carrier

Channel	Channel Frequency (MHz)	Results
Lowest	1921.536	Pass
Highest	1928.448	Pass

Please refer to the attached plots for more details:

Plot 4A1: 6041, Lowest Channel Unwanted Emission Inside the Sub-Band (Traffic Carrier)
Plot 4B1: 6041, Highest Channel Unwanted Emission Inside the Sub-Band (Traffic Carrier)
Plot 4C1: 6041, Lowest Channel Unwanted Emission Inside the Sub-Band (Dummy Carrier)
Plot 4D1: 6041, Highest Channel Unwanted Emission Inside the Sub-Band (Dummy Carrier)
Plot 4A2: 6042, Lowest Channel Unwanted Emission Inside the Sub-Band (Traffic Carrier)
Plot 4B2: 6042, Highest Channel Unwanted Emission Inside the Sub-Band (Traffic Carrier)
Plot 4C2: 6042, Lowest Channel Unwanted Emission Inside the Sub-Band (Dummy Carrier)
Plot 4D2: 6042, Highest Channel Unwanted Emission Inside the Sub-Band (Dummy Carrier)

The plots of the unwanted emission inside the sub-band are saved as filename: inband.pdf

INTERTEK TESTING SERVICES

Company: VTech Telecommunications Ltd.
Model: 6041, 6042

Date of Test: November 11-30, 2006

4.7 Emissions Outside the Sub-Band, FCC Rule 15.323(d):

Emissions outside the sub-band shall be attenuated below a reference power of 112 mW (20.5 dBm) as follows:

1. 30 dB between the band edge and 1.25 MHz above or below the band;
2. 50 dB between 1.25 and 2.5 MHz above or below the band; and
3. 60 dB at 2.5 MHz or greater above or below the band, or shall meet the requirement of FCC Rule 15.319(g) which shall not exceed the limits of FCC Rule 15.209.

Example: Calculation of Limit for emissions between the band edge and 1.25 MHz (1920.000 – 1918.750 MHz)

The emissions shall not exceed the Limit: 20.5 dBm – 30 dB = -9.5 dBm

Measurements are made in accordance with ANSI C63.17 sub-clause 6.1.6.2. As EUT has non-detachable antenna(s), radiated emissions test method is used for out-of-band emissions tests. Emissions that are directly caused by digital circuits in the transmit path and transmitter portion are measured. Test setup and procedures are described in section 3.2 Figure 3.2.1.

Test Results:

Channel	Carrier Frequency (MHz)	Measured Band (MHz)	Limit (dBm)	Results
Lowest	1921.536	1920.000 - 1918.750	-9.5	Pass
		1918.750 - 1917.500	-29.5	Pass
		0.009 - 1917.500 & 1932.500 - 19300.000	-39.5	Pass
Highest	1928.448	1930.000 - 1931.250	-9.5	Pass
		1931.250 - 1932.500	-29.5	Pass
		0.009 - 1917.500 & 1932.500 - 19300.000	-39.5	Pass

Please refer to the section 4.7.1 to 4.7.4 for more details.

INTERTEK TESTING SERVICES

Company: VTech Telecommunications Ltd.
Model: 6041, 6042
Mode: Transmission

Date of Test: November 11-30, 2006

4.7.1 Radiated Emissions Configuration Photographs:

Worst Case Radiated Emission
at

6041: 1932.620 MHz

6042: 1917.420 MHz

The worst case radiated emission configuration photographs are saved as filename:
cofing photos.doc.

INTERTEK TESTING SERVICES

Company: VTech Telecommunications Ltd.
Model: 6041, 6042
Mode: Transmission

Date of Test: November 11-30, 2006

4.7.2 Radiated Emissions Data:

Data are included of the worst case configuration (the configuration which resulted in the highest emission levels). A sample calculation, configuration photographs and data tables of the emissions are included. All measurements were performed with peak detection unless otherwise specified.

The data in table 1, 2, 3, 4, 5 and 6 list the significant emission frequencies, the limit and the margin of compliance.

Judgement -

6041: Passed by 4.6 dB margin

6042: Passed by 3.4 dB margin

TEST ENGINEER:



Signature

Felix Ng, Lead Engineer
Typed/Printed Name

December 30, 2006

Date

INTERTEK TESTING SERVICES

Company: VTech Telecommunications Ltd.
Model: 6041
Mode: Transmission

Date of Test: November 11-30, 2006

Table 1

Radiated Emissions Data Pursuant To FCC Part 15 Section 15.323 (d) Emissions Requirements

Lowest Channel:

Polarization	Frequency (MHz)	Emission Level at 3m (dBm)	Limit (dBm)	Margin (dB)
H	1919.807	-32.2	-9.5	-22.7
H	1918.630	-44.4	-29.5	-14.9
H	1917.430	-44.2	-39.5	-4.7
H	3843.098	-54.7	-39.5	-15.2
V	5764.647	-56.2	-39.5	-16.7
V	7686.196	-55.1	-39.5	-15.6
V	9607.745	-56.1	-39.5	-16.6
H	11529.294	-45.4	-39.5	-5.9

NOTES:

1. Peak detector is used for the emission measurement.
2. All measurements were made at 3 meters. Emissions not detected at the 3-meter distance were measured at 0.3-meter and an inverse proportional extrapolation was performed to compare the signal level to the 3-meter limit. No other emissions than those reported were detected at a test distance of 0.3-meter.
3. Negative value in the margin column shows emission below limit.
4. In the band at 2.5 MHz or greater above or below the band,
 - [x] Emissions are below the limit -39.5 dBm.
 - [] Emissions meet the requirement of FCC Rule 15.319(g), and are below the limits of FCC Rule 15.209.

INTERTEK TESTING SERVICES

Company: VTech Telecommunications Ltd.
Model: 6041
Mode: Transmission

Date of Test: November 11-30, 2006

Table 2

Radiated Emissions Data Pursuant To FCC Part 15 Section 15.323 (d) Emissions Requirements

Highest Channel:

Polarization	Frequency (MHz)	Emission Level at 3m (dBm)	Limit (dBm)	Margin (dB)
H	1930.174	-31.4	-9.5	-21.9
H	1931.314	-44.2	-29.5	-14.7
H	1932.620	-44.1	-39.5	-4.6
H	3856.912	-54.9	-39.5	-15.4
V	5785.368	-56.6	-39.5	-17.1
V	7713.824	-55.2	-39.5	-15.7
V	9642.280	-56.2	-39.5	-16.7
H	11570.736	-45.6	-39.5	-6.1

NOTES:

1. Peak detector is used for the emission measurement.
2. All measurements were made at 3 meters. Emissions not detected at the 3-meter distance were measured at 0.3-meter and an inverse proportional extrapolation was performed to compare the signal level to the 3-meter limit. No other emissions than those reported were detected at a test distance of 0.3-meter.
3. Negative value in the margin column shows emission below limit.
4. In the band at 2.5 MHz or greater above or below the band,
 - [x] Emissions are below the limit -39.5 dBm.
 - [] Emissions meet the requirement of FCC Rule 15.319(g), and are below the limits of FCC Rule 15.209.

INTERTEK TESTING SERVICES

Company: VTech Telecommunications Ltd.
Model: 6042
Mode: Transmission

Date of Test: November 11-30, 2006

Table 3

Radiated Emissions Data Pursuant To FCC Part 15 Section 15.323 (d) Emissions Requirements

Lowest Channel:

Polarization	Frequency (MHz)	Emission Level at 3m (dBm)	Limit (dBm)	Margin (dB)
H	1919.808	-31.9	-9.5	-22.4
H	1918.510	-43.6	-29.5	-14.1
H	1917.420	-42.9	-39.5	-3.4
V	3843.150	-50.9	-39.5	-11.4
V	5764.725	-52.7	-39.5	-13.2
V	7686.300	-60.8	-39.5	-21.3
H	9607.875	-60.3	-39.5	-20.8
H	11529.450	-43.8	-39.5	-4.3
H	13451.025	-59.2	-39.5	-19.7

NOTES:

1. Peak detector is used for the emission measurement.
2. All measurements were made at 3 meters. Emissions not detected at the 3-meter distance were measured at 0.3-meter and an inverse proportional extrapolation was performed to compare the signal level to the 3-meter limit. No other emissions than those reported were detected at a test distance of 0.3-meter.
3. Negative value in the margin column shows emission below limit.
4. In the band at 2.5 MHz or greater above or below the band,
 - [x] Emissions are below the limit -39.5 dBm.
 - [] Emissions meet the requirement of FCC Rule 15.319(g), and are below the limits of FCC Rule 15.209.

INTERTEK TESTING SERVICES

Company: VTech Telecommunications Ltd.
Model: 6042
Mode: Transmission

Date of Test: November 11-30, 2006

Table 4

Radiated Emissions Data Pursuant To FCC Part 15 Section 15.323 (d) Emissions Requirements

Highest Channel:

Polari- zation	Frequency (MHz)	Emission Level at 3m (dBm)	Limit (dBm)	Margin (dB)
H	1930.169	-31.5	-9.5	-22.0
H	1931.305	-43.3	-29.5	-13.8
H	1932.605	-43.0	-39.5	-3.5
V	3856.960	-50.0	-39.5	-10.5
V	5785.440	-53.8	-39.5	-14.3
V	7713.920	-60.4	-39.5	-20.9
H	9642.400	-60.2	-39.5	-20.7
H	11570.880	-44.2	-39.5	-4.7
H	13499.360	-58.9	-39.5	-19.4

NOTES:

1. Peak detector is used for the emission measurement.
2. All measurements were made at 3 meters. Emissions not detected at the 3-meter distance were measured at 0.3-meter and an inverse proportional extrapolation was performed to compare the signal level to the 3-meter limit. No other emissions than those reported were detected at a test distance of 0.3-meter.
3. Negative value in the margin column shows emission below limit.
4. In the band at 2.5 MHz or greater above or below the band,
 - [x] Emissions are below the limit -39.5 dBm.
 - [] Emissions meet the requirement of FCC Rule 15.319(g), and are below the limits of FCC Rule 15.209.

INTERTEK TESTING SERVICES

Company: VTech Telecommunications Ltd.
Model: 6041
Mode: Talk

Date of Test: November 11-30, 2006

Table 5

**Radiated Emissions Data
Pursuant To FCC Part 15 Section 15.323 (d) Emissions Requirements**

Polari- zation	Frequency (MHz)	Emission Level at 3m (dBm)	Limit (dBm)	Margin (dB)
H	110.591	-71.4	-39.5	-31.9
H	124.415	-71.8	-39.5	-32.3
H	138.239	-68.9	-39.5	-29.4
H	221.185	-72.5	-39.5	-33.0
H	331.777	-67.8	-39.5	-28.3
H	387.073	-70.5	-39.5	-31.0
H	456.193	-64.6	-39.5	-25.1
H	552.961	-62.4	-39.5	-22.9
H	622.081	-61.9	-39.5	-22.4
H	649.729	-64.4	-39.5	-24.9
H	691.201	-57.8	-39.5	-18.3
H	760.321	-61.4	-39.5	-21.9

NOTES:

1. Peak detector is used for the emission measurement.
2. All measurements were made at 3 meters. Emissions not detected at the 3-meter distance were measured at 0.3-meter and an inverse proportional extrapolation was performed to compare the signal level to the 3-meter limit. No other emissions than those reported were detected at a test distance of 0.3-meter.
3. Negative value in the margin column shows emission below limit.
4. In the bands 0.009 - 1917.500 MHz & 1932.500 - 19300.000 MHz,
 - [x] Emissions are below the limit -39.5 dBm.
 - [] Emissions meet the requirement of FCC Rule 15.319(g), and are below the limits of FCC Rule 15.209.

INTERTEK TESTING SERVICES

Company: VTech Telecommunications Ltd.
Model: 6042
Mode: Talk

Date of Test: November 11-30, 2006

Table 6

**Radiated Emissions Data
Pursuant To FCC Part 15 Section 15.323 (d) Emissions Requirements**

Polari- zation	Frequency (MHz)	Emission Level at 3m (dBm)	Limit (dBm)	Margin (dB)
V	69.115	-70.6	-39.5	-31.1
H	124.410	-66.6	-39.5	-27.1
H	165.881	-69.7	-39.5	-30.2
H	221.190	-68.6	-39.5	-29.1
H	304.125	-67.9	-39.5	-28.4
H	387.069	-67.3	-39.5	-27.8
H	483.837	-66.3	-39.5	-26.8
H	580.605	-56.7	-39.5	-17.2
H	677.378	-59.4	-39.5	-19.9
H	774.141	-60.4	-39.5	-20.9

NOTES:

1. Peak detector is used for the emission measurement.
2. All measurements were made at 3 meters. Emissions not detected at the 3-meter distance were measured at 0.3-meter and an inverse proportional extrapolation was performed to compare the signal level to the 3-meter limit. No other emissions than those reported were detected at a test distance of 0.3-meter.
3. Negative value in the margin column shows emission below limit.
4. In the bands 0.009 - 1917.500 MHz & 1932.500 - 19300.000 MHz,
 - [x] Emissions are below the limit -39.5 dBm.
 - [] Emissions meet the requirement of FCC Rule 15.319(g), and are below the limits of FCC Rule 15.209.

INTERTEK TESTING SERVICES

Company: VTech Telecommunications Ltd.
Model: 6041, 6042

Date of Test: November 11-30, 2006

4.7.3 Field Strength Calculation

The field strength is calculated by adding the reading on the Spectrum Analyzer to the factors associated with preamplifiers (if any), antennas, cables, pulse desensitization and average factors (when specified limit is in average and measurements are made with peak detectors). A sample calculation is included below.

$$FS = RA + AF + CF - AG + PD + AV$$

Where

- FS = Field Strength in dB μ V/m
- RA = Receiver Amplitude (including preamplifier) in dB μ V
- CF = Cable Attenuation Factor in dB
- AF = Antenna Factor in dB
- AG = Amplifier Gain in dB
- PD = Pulse Desensitization in dB
- AV = Average Factor in -dB

In the radiated emission table which follows, the reading shown on the data table may reflect the preamplifier gain. An example of the calculations, where the reading does not reflect the preamplifier gain, follows:

$$FS = RA + AF + CF - AG + PD + AV$$

Example

Assume a receiver reading of 62.0 dB μ V is obtained. The antenna factor of 7.4 dB and cable factor of 1.6 dB is added. The amplifier gain of 29.0 dB is subtracted. The pulse desensitization factor of the spectrum analyzer is 0.0 dB, and the resultant average factor is -10.0 dB. The net field strength for comparison to the appropriate emission limit is 32.0 dB μ V/m. This value in dB μ V/m is converted to its corresponding level in μ V/m.

RA = 62.0 dB μ V
AF = 7.4 dB
CF = 1.6 dB
AG = 29.0 dB
PD = 0.0 dB
AV = -10 dB

$$FS = 62.0 + 7.4 + 1.6 - 29.0 + 0.0 + (-10.0) = 32.0 \text{ dB}\mu\text{V/m}$$

$$\text{Level in mV/m} = \text{Common Antilogarithm} [(32.0 \text{ dB}\mu\text{V/m})/20] = 39.8 \mu\text{V/m}$$

INTERTEK TESTING SERVICES

Company: VTech Telecommunications Ltd.
Model: 6041, 6042

Date of Test: November 11-30, 2006

4.7.4 Average Factor Calculation and Transmitter ON Time Measurements, FCC Rule 15.35(b, c)

The EUT antenna output port was connected to the input of the spectrum analyzer. The analyzer center frequency was set to EUT RF channel carrier. The SPAN function on the analyzer was set to ZERO. The transmitter ON time was determined from the resultant time-amplitude display:

- Please refer to the attached plots for more details:
Plot 5A: Transmitter ON Time Measurements (Traffic Carrier)
Plot 5B: Transmitter ON Time Measurements (Dummy Carrier)

The plots of Transmitter ON Time Measurements are saved as filename:
txon.pdf

- Please refer to the attached transmitter timing diagram that are provided by manufacturer
- Not applicable - No average factor is required.

INTERTEK TESTING SERVICES

Company: VTech Telecommunications Ltd.
Model: 6041, 6042

Date of Test: November 11-30, 2006

4.8 AC Power Lines Conducted Emissions from Transmitter portion of EUT, FCC Rule 15.315:

The AC power lines conducted emission shall not exceed the limits of FCC Rule 15.207.

Measurements are made in accordance with ANSI C63.4 sub-clause 7. Emissions that are directly caused by digital circuits in the transmit path and transmitter portion are measured.

Not applicable – EUT is only powered by battery for operation.

EUT connects to AC power lines. Emission Data are listed in following pages. Please refer to the section 4.8.1 to 4.8.2 for more details.

INTERTEK TESTING SERVICES

Company: VTech Telecommunications Ltd.
Model: 6041, 6042
Mode: Talk

Date of Test: November 11-30, 2006

4.8.1 AC Power Lines Conducted Emissions Configuration Photographs:

Worst Case AC Power Line Conducted Emission

The worst case AC power Line conducted emission configuration photographs are saved as filename: config photos.doc

INTERTEK TESTING SERVICES

Company: VTech Telecommunications Ltd.
Model: 6041, 6042
Mode: Talk

Date of Test: November 11-30, 2006

4.8.2 AC Power Line Conducted Emissions Data:

The data on the following pages list the significant emission frequencies, the limit, and the margin of compliance.

Judgment: Passed by more than 20 dB margin

The worst case AC power line conducted emission data are saved as filename: conduct.pdf

TEST ENGINEER:



Signature

Felix Ng, Lead Engineer
Typed/Printed Name

December 30, 2006

Date

INTERTEK TESTING SERVICES

Company: VTech Telecommunications Ltd.
Model: 6041, 6042

Date of Test: November 11-30, 2006

4.9 Radiated Emissions from Computing Device Peripheral Portion of EUT, FCC Rule 15.109(a):

EUT includes computing device peripheral circuitry and is subject to the requirements of FCC Part 15 Subpart B. The radiated emission shall not exceed the limits of FCC Rule 15.109(a).

Measurements are made in accordance with ANSI C63.4 sub-clause 8 and section 3.1. Radiated emissions shall be measured with EUT operating in typical operation modes. The spectrum analyzer resolution bandwidth was 100 kHz or greater for frequencies below 1000 MHz.

Not applicable – No computing device peripheral

The computing device peripheral portion of EUT is subject to FCC Part 15 Subpart B, Certification. Please refer to the section 4.9.1 for more details.

The computing device peripheral portion of EUT is subject to FCC Part 15 Subpart B, DoC. Emission Data are included in the separated DoC report.

INTERTEK TESTING SERVICES

Company: VTech Telecommunications Ltd.
Model: 6041, 6042

Date of Test: November 11-30, 2006

4.10 AC Power Lines Conducted Emissions from Computing Device Peripheral Portion of EUT, FCC Rule 15.107(a):

EUT includes computing device peripheral and is subject to the requirements of FCC Part 15 Subpart B. The AC power lines conducted emission shall not exceed the limits of FCC Rule 15.107(a).

Measurements are made in accordance with ANSI C63.4 sub-clause 7. Conducted emissions shall be measured with EUT operating in typical operation modes.

- Not applicable – No computing device peripheral
- The computing device peripheral portion of EUT is subject to FCC Part 15 Subpart B, Certification. Please refer to the section 4.10.1 for more details.
- The computing device peripheral portion of EUT is subject to FCC Part 15 Subpart B, DoC. Emission Data are included in the separated DoC report.

INTERTEK TESTING SERVICES

Company: VTech Telecommunications Ltd.
Model: 6041, 6042

Date of Test: November 11-30, 2006

4.11 Radio Frequency Radiation Exposure, FCC Rule 15.319(i):

EUT is subject to the radio frequency exposure requirements specified in FCC Rule §§ 1.1307(b), 2.1091 and 2.1093. It shall be considered to operate in a "general population / uncontrolled" environment.

- EUT was evaluated for Specific Absorption Rate (SAR) evaluation compliance according to OET Bulletin 65, Supplement C (Edition 01-01). It is in compliance with the SAR evaluation requirements. The caution statement is specified in the user manual. A SAR test report was submitted at same time and saved as SAR report 1 of 2.pdf and SAR report 2 of 2.pdf
- EUT was evaluated for Maximum Permissible Exposure (MPE) evaluation compliance according to OET Bulletin 65, Supplement C (Edition 01-01). The evaluation calculation results are saved as filename: RF exposure info.pdf

INTERTEK TESTING SERVICES

Company: VTech Telecommunications Ltd.
Model: 6041, 6042

Date of Test: November 11-30, 2006

4.12 Monitoring Antenna, FCC Rule 15.323(c)(8):

The monitoring system shall use the same antenna used for transmission, or an antenna that yields equivalent reception at that location.

EUT uses the same antenna used for transmission and monitoring that is in compliance meet above provision.

EUT uses difference antenna used for transmission and monitoring. It must be verified that the monitoring antenna provides coverage equivalent to that of the transmitting antenna. Measurements are made in accordance with ANSI C63.17 sub-clause 4.

**EXHIBIT 5
EQUIPMENT PHOTOGRAPHS**

INTERTEK TESTING SERVICES

5.0 Equipment Photographs

The photographs are saved as filename: external photos.doc & internal photos.doc

**EXHIBIT 6
PRODUCT LABELLING**

INTERTEK TESTING SERVICES

6.0 Product Labelling

The FCC ID label artwork and its location are saved as filename: label.pdf

**EXHIBIT 7
TECHNICAL SPECIFICATIONS**

INTERTEK TESTING SERVICES

7.0 Technical Specifications

The block diagram and circuit diagram are saved as filename: block.pdf and circuit.pdf respectively.

**EXHIBIT 8
INSTRUCTION MANUAL**

INTERTEK TESTING SERVICES

8.0 Instruction Manual

A preliminary copy of the Instruction Manual is saved as filename: manual.pdf

The required FCC Information to the User is stated on P.53 of Instruction Manual.

This manual will be provided to the end-user with each unit sold/leased in the United States.

**EXHIBIT 9
UTAM Affidavit**

INTERTEK TESTING SERVICES

9.0 UTAM Affidavit

A copy of the UTAM affidavit is saved as filename: utam.pdf

INTERTEK TESTING SERVICES

**EXHIBIT 10
CONFIDENTIALITY REQUEST**

INTERTEK TESTING SERVICES

10.0 Confidentiality Request

A copy of the Confidentiality Request is saved as filename: request.pdf