



**Test Report:** 4W33046 Issue 2

**Applicant:** VTech Engineering Canada Ltd.  
Suite 200 – 7671 Alderbridge Way  
Richmond, B.C.,  
Canada  
V6X 1Z9

**Equipment Under Test:  
(EUT)** VTech 5829,5851 Handset

**FCC ID:** EW780-5587-01

**In Accordance With:** **FCC Part 15, Subpart C, 15.249**

**Tested By:** Nemko Canada Inc.  
303 River Road, R.R. 5  
Ottawa, Ontario K1V 1H2

**Authorized By:** Glen Westwell, Wireless Specialist

**Date:** 9 December 2004

**Total Number of Pages:** 15

**Table Of Contents**

**Section 1. Summary Of Test Results .....3**

**Section 2. General Equipment Specification .....5**

**Section 3. Radiated Emissions .....7**

**Section 4. Occupied Bandwidth .....10**

**Section 5. Block Diagrams.....14**

**Section 6. Test Equipment List.....15**

*EQUIPMENT: Vtech 5829,5851 Handset*

---

## **Section 1. Summary Of Test Results**

### **General**

All measurements are traceable to national standards.

These tests were conducted on a sample of the equipment for the purpose of demonstrating compliance with FCC Part 15.249. All tests were conducted using measurement procedure ANSI C63.4-2001. Radiated Emissions were made on an open area test site. A description of the test facility is on file with the FCC.

THIS TEST REPORT RELATES ONLY TO THE ITEM(S) TESTED.

THE FOLLOWING DEVIATIONS FROM, ADDITIONS TO, OR EXCLUSIONS FROM THE TEST SPECIFICATIONS HAVE BEEN MADE.

See " Summary of Test Data".



TESTED BY: \_\_\_\_\_  
Chris Maidens, EMC Specialist

DATE: 9 December 2004

Nemko Canada Inc. authorizes the above named company to reproduce this report provided it is reproduced in its entirety and for use by the company's employees only.

Any use which a third party makes of this report, or any reliance on or decisions to be made based on it, are the responsibility of such third parties. Nemko Canada Inc. accepts no responsibility for damages, if any, suffered by any third party as a result of decisions made or actions based on this report.

This report applies only to the items tested.

*EQUIPMENT: Vtech 5829,5851 Handset*

---

**Summary Of Test Data**

<b>Name Of Test</b>	<b>Para. No.</b>	<b>Result</b>
Conducted Emissions	15.207	N/A (1)
Radiated Emissions	15.249	Complied

**Justification for N/A:** The EUT is battery powered.

**Test Conditions:**

**Indoor**                      Temperature: 22°C  
   Humidity: 30%

**Outdoor**                     Temperature: 10°C  
   Humidity: 30%

*EQUIPMENT: Vtech 5829,5851 Handset*

---

**Section 2.           General Equipment Specification**

**Manufacturer:** VTech (Dongguan) Electronics and Communications Ltd.  
Xia Ling Bei Management Zone,  
Liaobu, Dongguan, guangdong,  
China 523411

**Model No.:** 5829, 5851

**Serial No.:** None.

**Date Received In Laboratory:** November 8, 2004

**Nemko Identification No.:** See Nemko Receiving Report

**EUT Description:**

- The 5829 is a cordless phone system consisting of a CID handset unit that transmits in the 5863.8 to 5872.5MHz range, and a base unit that transmits in the 912.75 to 917.1MHz range.
- The 5851 system uses the same frequencies, but has a digital answering machine built in to the base.

**Tx Frequency Range:** 5863.8-5872.5MHz

**Number of Channels:** 30

**Emission Designator:** 633KF3E & 100KF1D

**Modulation:** Voice: FM  
Data: FSK

**Rated Power:** Transmit power is fixed at an output power which produces less than 94 dBuV at 3m

EQUIPMENT: Vtech 5829,5851 Handset

**EUT Configuration**

Equipment Configuration List		
Item	Description	Identification: (M/N #, S/N #, P/N #, Rev.)
A	Handset	None.
B	Headset with mini-din cable integral	None.
C	Base Unit	M/N: ia5829, ia5839, ia5851, or ia5859
D	-48V DC feed	None.
E	Component telephone power supply Class 2	M/N: UO93040D (with the ia5829 or ia5839) M/N: UO90050D (with the ia5851 or the ia5859)

EUT Ports				
Item	Description	Indoor/Outdoor	Type (See Legend)	Qty
i	AC Mains Input	Outdoor	1	1
ii	PSTN	Outdoor	3	1
iii	Headset	Indoor	4	1

Inter-Connection Cables				
Item	Description	Shielded	Ferrite	Length (m)
1	RJ11 to RJ11 Standards telephone cable	No	No	1.5

Legend:  
1 = AC Power Input/Output, 2 = DC Power Input/Output, 3 = Telecom, 4 = Non-telecom I/O, 5 = Maintenance, 6 = Fiber Optic

Notes  
None

*Configuration of the Equipment Under Test (EUT)*

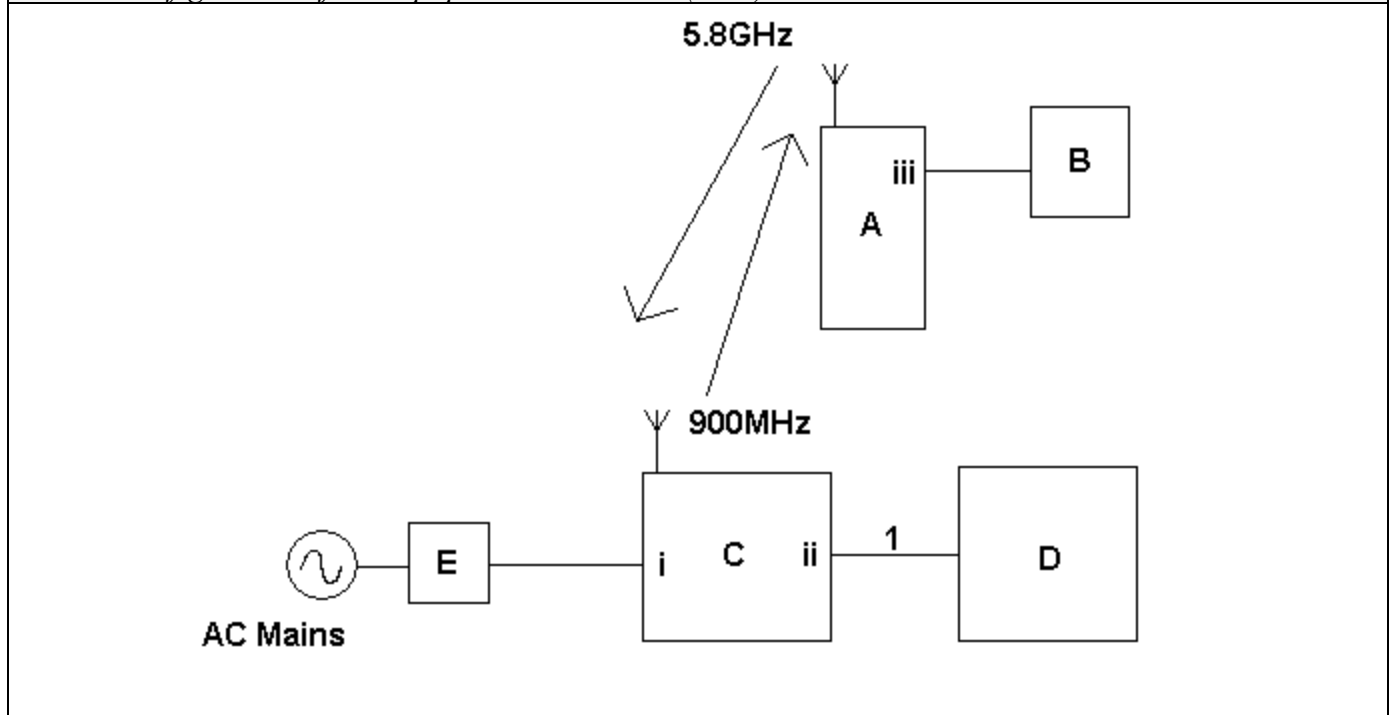

*EQUIPMENT: Vtech 5829,5851 Handset*

---

**Section 3. Radiated Emissions**

Para. No.: 15.249

<b>Test Performed By: Chris Maidens</b>	<b>Date of Test: Nov 9 &amp; 10, 2004</b>
---	---

**Minimum Standard:**

<b>Fundamental (MHz)</b>	<b>Field Strength (mV/m)</b>	<b>Field Strength (dBµV)</b>	<b>Harmonic (mV/m)</b>	<b>Harmonic (dBµV)</b>
902-928	50	94	0.5	54

**Test Results:** Complied

**Measurement Data:** See attached tabulated data.

EQUIPMENT: Vtech 5829,5851 Handset

**Radiated Emissions:**

Tested as per: Hand-Held							Mains Input: 120VAC, 60Hz				
Test Distance (meters): 3							Dome: 1				
<b>Channel 14 (middle channel)</b>											
Freq. (MHz)	Ant.	Pol. V/H	RCVD Signal (dBμV)	Ant. Factor (dB)	Amp. Gain (dB)	Cable Loss (dB)	Field Strength (dBμV/m)	Limit (dBμV/m)	Margin (dB)	Detector	Amp.
5868.0000	Horn1	H	41.5	34.7	0	10.3	86.5	94.0	7.5	Peak	N/A
5868.0000	Horn1	V	36.7	34.8	0	10.3	81.8	94.0	12.2	Peak	N/A
11736.0000	Horn1	H	45.2	39.5	41.0	3.3	47	54.0	7.0	Peak	5-18
11736.0000	Horn1	V	46.3	39.4	41.0	3.3	48	54.0	6.0	Peak	5-18
<b>Channel 29 (high channel)</b>											
Freq. (MHz)	Ant.	Pol. V/H	RCVD Signal (dBμV)	Ant. Factor (dB)	Amp. Gain (dB)	Cable Loss (dB)	Field Strength (dBμV/m)	Limit (dBμV/m)	Margin (dB)	Detector	Amp.
5872.5000	Horn1	H	42.5	34.7	0	10.3	87.5	94.0	6.5	Peak	N/A
5872.5000	Horn1	V	38.2	34.8	0	10.3	83.3	94.0	10.7	Peak	N/A
11745.0000	Horn1	H	45.8	39.5	41.0	3.5	47.8	54.0	6.2	Peak	5-18
11745.0000	Horn1	V	45.8	39.4	41.0	3.5	47.7	54.0	6.3	Peak	5-18
<b>Channel 0 (low channel)</b>											
Freq. (MHz)	Ant.	Pol. V/H	RCVD Signal (dBμV)	Ant. Factor (dB)	Amp. Gain (dB)	Cable Loss (dB)	Field Strength (dBμV/m)	Limit (dBμV/m)	Margin (dB)	Detector	Amp.
5863.8000	Horn1	H	41.3	34.7	0	10.3	86.3	94.0	7.7	Peak	N/A
5863.8000	Horn1	V	38.8	34.8	0	10.3	83.9	94.0	10.1	Peak	N/A
11727.6000	Horn1	H	46.3	39.5	41.0	3.3	48.1	54.0	5.9	Peak	5-18
11727.6000	Horn1	V	45.5	39.4	41.0	3.3	47.2	54.0	6.8	Peak	5-18
Antenna Legend: BC = Biconical, BL = Bilog, LP = Log-Periodic, Horn = Horn, ED = EMCO Dipole											
<b>Notes</b>											
<ol style="list-style-type: none"> <li>1) A measurement BW of 1MHz was used.</li> <li>2) The EUT was verified in 3 orthogonal axes, and the worst case orientation has been reported (as photographed in the setup photo)</li> <li>3) The spectrum was searched from 8MHz up to the 10<sup>th</sup> harmonic (58.725GHz) No emissions were detected other than those reported in this table.</li> <li>4) The EUT was tested with a fully charged battery.</li> <li>5) The EUT was verified in both voice and data mode. Data mode was the worst case, therefore it has been reported.</li> <li>6) Measurements &gt;8GHz were performed at 1m and the emission was adjusted with the formula <math>20\log(d1/d2)</math></li> </ol>											

*EQUIPMENT: Vtech 5829,5851 Handset*

---

**EUT Setup Photo:**





EQUIPMENT: Vtech 5829,5851 Handset

Handset: Voice (continued)

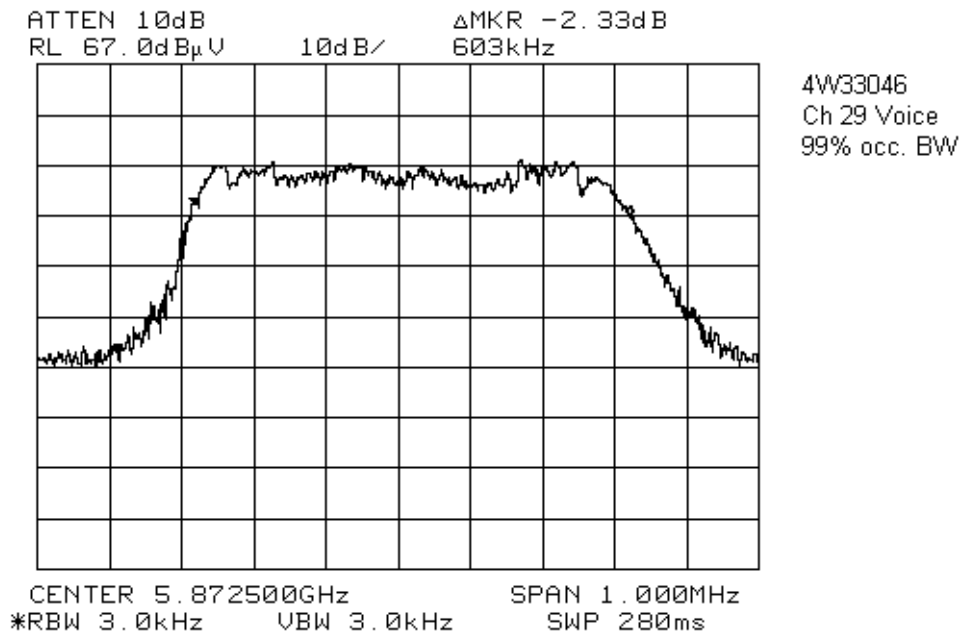

EQUIPMENT: Vtech 5829,5851 Handset

Handset: Data

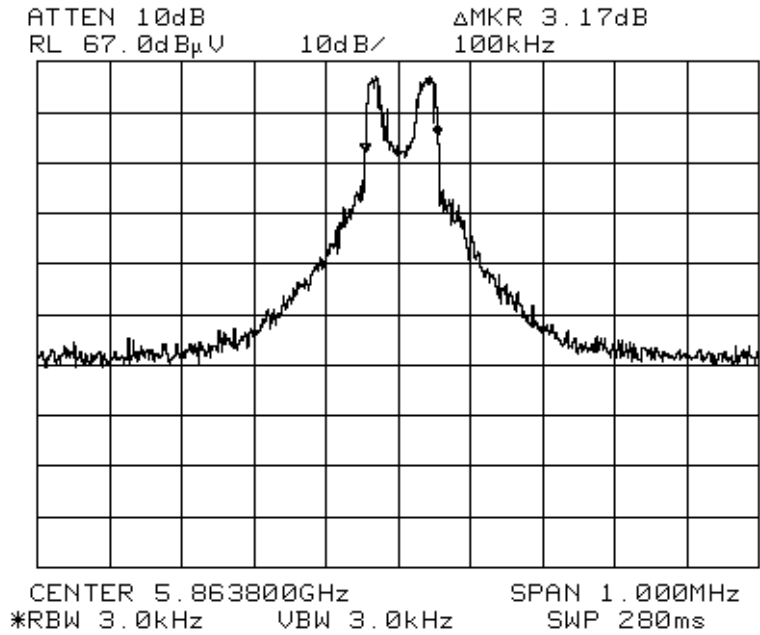

4W33046  
Ch 0 Data  
99% Occ. BW

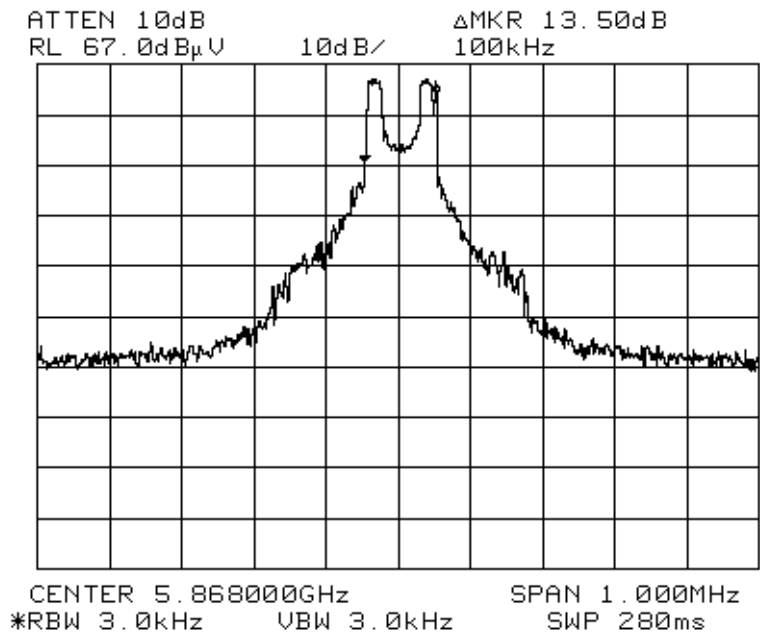

4W33046  
Ch 14 Data  
99% Occ. BW

EQUIPMENT: Vtech 5829,5851 Handset

Handset: Data (continued)

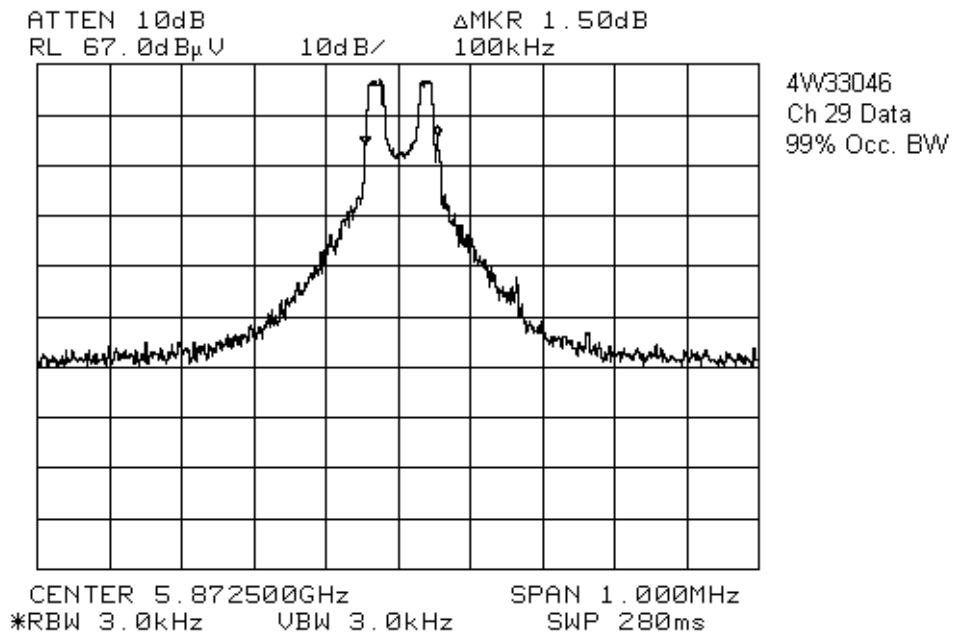

EQUIPMENT: Vtech 5829,5851 Handset

---

## Section 5. Block Diagrams

### Test Site For Radiated Emissions

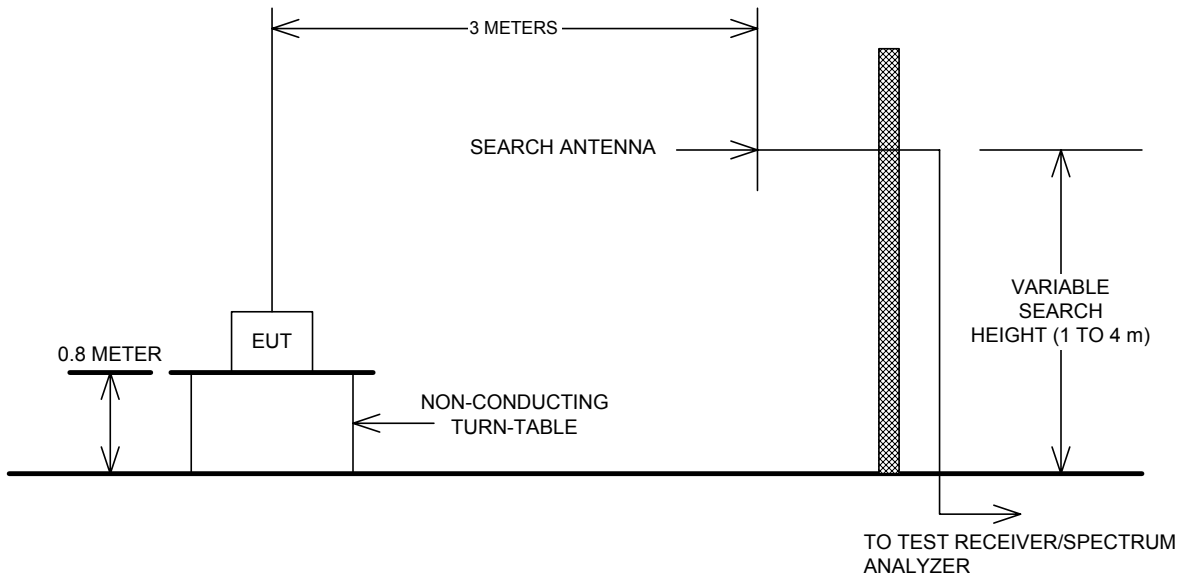

The spectrum was search up to the 10<sup>th</sup> harmonic of the fundamental frequency of operation.

EQUIPMENT: Vtech 5829,5851 Handset

**Section 6. Test Equipment List**

*Equipment List - Radiated Emissions*

CAL Cycle	Equipment	Manufacturer	Model No.	Asset/Serial No.	Last Cal.	Next Cal.
1 Year	Receiver	Rohde & Schwarz	ESVP	FA000871	Jan. 16/04	Jan. 16/05
1 Year	Spectrum Analyzer	Hewlett-Packard	8565E	FA000981	May 31/04	May 31/05
1 Year	Biconical (1) Antenna	EMCO	3109	FA000805	April 23/04	April 23/05
1 Year	Horn Antenna #1	EMCO	3115	FA000649	Dec. 18/03	Dec. 18/04
1 Year	Log Periodic Antenna #2	EMCO	3148	FA001355	May 05/04	May 05/05
1 Year	Active Loop Antenna	EMCO	6502	FA001686	July 19/04	July 19/05
1 Year	Horn Antenna	ETS	3116	FA001847	Jan. 19/04	Jan. 19/05
1 Year	1.0 – 2.0 GHz Amplifier	JCA	12-400	FA001498	June 18/04	June 18/05
1 Year	2.0 – 4.0 GHz Amplifier	JCA	24-600	FA001496	June 18/04	June 18/05
1 Year	4.0 – 8.0 GHz Amplifier	JCA	48-600	FA001497	June 18/04	June 18/05
COU	5.0 – 18.0 GHz Amplifier	NARDA	DWT-186N23U40	FA001409	COU	COU
COU	18.0 – 26.0 GHz Amplifier	NARDA	BBS-1826N612	FA001550	COU	COU
COU	26 – 40.0 GHz Amplifier	NARDA	DBL-2640N610	FA001556	COU	COU

Note: N/A = Not Applicable, NCR = No Cal Required, COU = CAL On Use, OUT = Out For CAL/Repair