



ENGINEERING CANADA LTD.

200-7671 Alderbridge Way, Richmond B.C. Canada V6X 1Z9

FAX: (604) 276-9137

TEL: (604) 273-5131

Date: February 6, 2002

Curtis-Straus LLC
527 Great Road
Littleton, MA 01460

Attn: Barry Quinlan

Justification for Class II permissive change – AT&T1430
FCC ID: EW780-5125-H01 & EW780-5125-B01

Dear Barry,

Attached is the amended difference table with more appropriate wordings in describing the RF changes – Handset RF section item (1) & Base RF section item (2)

Supporting information

- a) Internal block diagrams of U3515 (old) & U3517B (new) – attached.
U3515 is a 900MHz RF IC, so in previous design the Rx PLL, VCO, LNA, Mixer could not be used on Handset receive (2.4GHz).
In the new U3517B, the Rx PLL, VCO are re-designed for 2.4GHz, so previous external discrete Rx PLL, VCO are no longer required. The unused LNA, Mixer insider U3515 were not implemented in the new RF IC U3517B as shown in the block diagram.
- b) The above was also mentioned in the Theory of Operation filed in FCC during previous new approval (10/1/01) on EW780-5125-H01 & EW780-5125-B01. The full doc. can be available for comparison when request.

3.2.2 Rx VCO and PLL

*.....
In case of 2.4GHz operation, as UAA3517A has not been available yet, external devices including PLL(MB15E07SL-Fujitsu), VCO, LNA and mixer(BGD2022-Philips) have to be used in co-operated with UAA3515A. The VCO is oscillating at 1.2GHz and the second harmonic 2.4GHz is then selected as LO. The 1.2GHz is then fed back to the PLL for comparison. The IF frequency feeding in the UAA3515A is 12.3MHz instead of 10.7MHz.*

Justifications for Class II modification

Handset :

- 1) Tx – using discrete components to replace LC filter is not considered as major change.
- 2) Rx – the integration of Rx PLL & VCO to RF IC U3517B is a planned migration that keeps all RF stages & frequencies remain the same. This will not affect the intended radiation & the unintended radiation was tested & verified to be within FCC limits.

Base :

- 1) Tx – the Tx doubler & Tx PA are the fundamentally the same. They use the same active components (Transistors). The minor changes made on the passive components are for performance improvement only. Same as Handset, the LC filter is replaced by discrete components for cost reduction. All these changes are minor changes that shall be within the scope of Class II Permissive Change.
- 2) Rx – No change.

If you require further information, please don't hesitate to contact me.
I am appreciated if you can let me know your judgement & process the application at your earliest convenience.

Thanks for your assistance in advance.

Yours sincerely,

Joseph Poon
Regulatory Compliance Manager

The description Difference Between AT&T1430 and AT&T1430MK2

1. Function

	AT&T1430	AT&T1430MK2
Handset	Same	No "Extension In Use" Display; Nn "No Line" Display
Base	Same	Same

2. Handset Block Diagram

	AT&T1430	AT&T1430MK2
RF section		Base on MK1,details of modification: 1. Integrated the external RX PLL and RX VCO into RF IC U3517B. 2. Canceled 2.8V Regulator. 3. Used U3517B to replace U3515. 4. Discrete components BPF in stead of 915MHz LC filter.
Audio circuit		1. Cancel 5V LCD, use 6V LCD. 2. Added a control circuit for RF 2.8V supply. (Q6,Q7)
MCU circuit	same	same
Power management		1. New DC voltage arrangement--- use 3.0V regulator to replace 2.5V.

3. Base Block Diagram

	AT&T1430	AT&T1430MK2
RF section	same	Base on MK1,details of modification: 1. Discrete components BPF in stead of 2.416GHz LC filter. 2. Minor changes to TX doubler and TX PA.
LIne interface	same	same
Power management	same	same
MCU circuit	same	same
Audio circuit		1. New TX_DATA path circuits have Been used. 2. The Battery charging current change from 85mA to 60mA.

900MHz Analog Cordless Telephone IC

UAA3515A/S1

BLOCK DIAGRAM

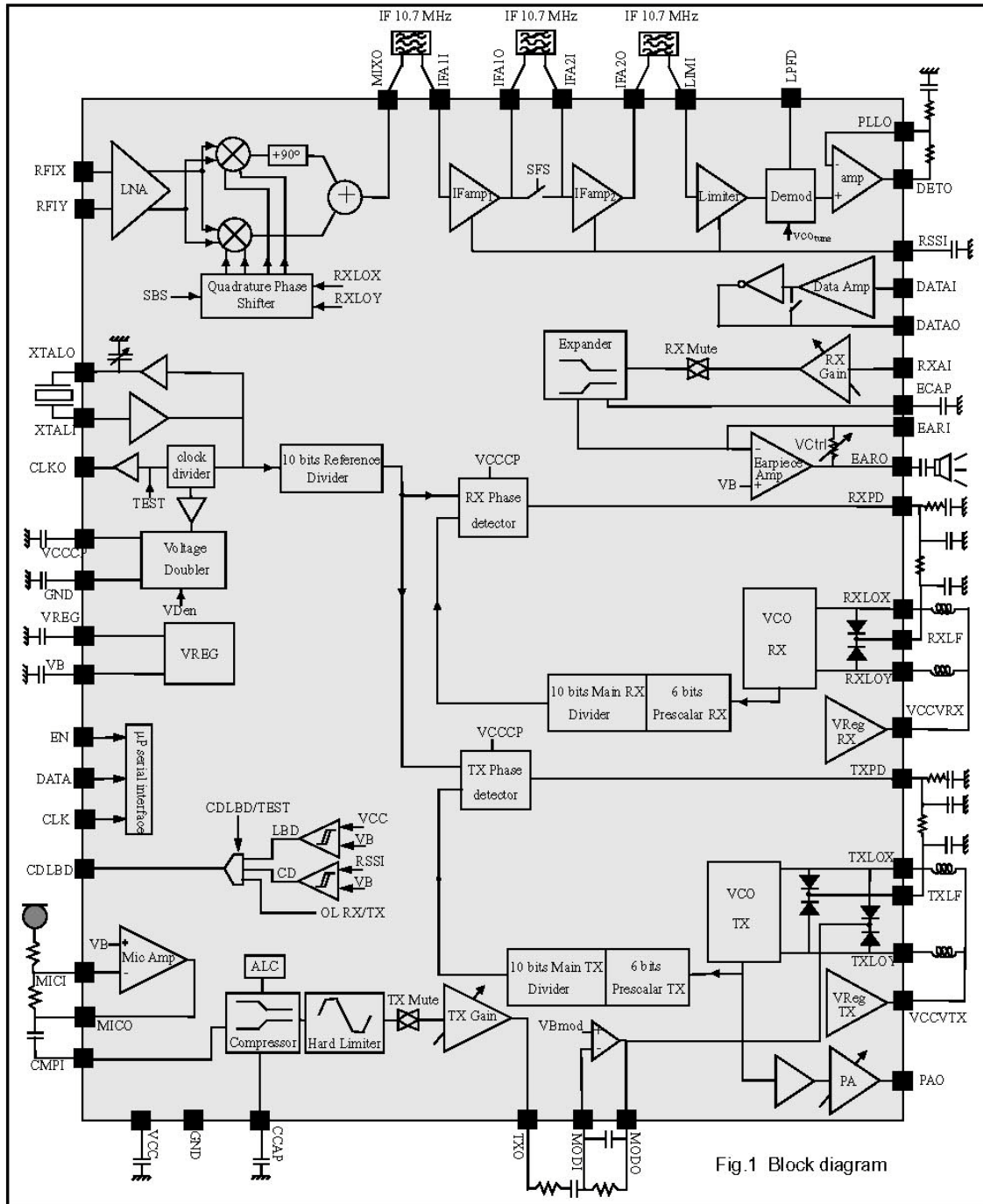

2.4Ghz/900MHz Analog Cordless Telephone IC

UAA3517B

BLOCK DIAGRAM

