

KTL Test Report: 8R01348.1

Applicant: VTECH Engineering Canada Ltd.
200 - 7671 Alderbridge Way
Richmond, B.C.
V6X 1Z9

**Equipment Under Test:
(E.U.T.)** Sony SPP-ID970 900 MHz Cordless Telephone

FCC ID: EW780-4282-00

In Accordance With: **FCC Part 15, Subpart C, 15.249**
For 900 MHz Cordless Telephones

Tested By: KTL Ottawa Inc.
3325 River Road, R.R. 5
Ottawa, Ontario K1V 1H2

Authorized By:

T. Tidwell, Laboratory Manager

Date:

Total Number of Pages: 25

EQUIPMENT: Sony SPP-ID970 900 MHz Cordless Telephone
FCC ID: EW780-4282-00

Table Of Contents

Section 1. Summary of Test Results

General
Summary of Test Data

Section 2. General Equipment Specification

Specifications
Modifications
Theory of Operation
System Diagram

Section 3. Powerline Conducted Emissions

Test Results
Graphs
Photographs

Section 4A. Radiated Emissions (Base)

Base Test Results
Base Data Table
Base Photographs

Section 4B. Radiated Emissions (Handset)

Handset Test Results
Handset Data Table
Handset Photographs

Section 5. Test Equipment List

Annex A. Test Diagrams

Conducted Emissions
Radiated Prescan
Test Site for Radiated Emissions

Annex B. Restricted Bands

EQUIPMENT: Sony SPP-ID970 900 MHz Cordless Telephone
FCC ID: EW780-4282-00

Section 1. Summary Of Test Results

Manufacturer: VTECH Engineering Canada Ltd.

Model No.: SPP-ID970

Serial No.: None

General: **All measurements are traceable to national standards.**

These tests were conducted on a sample of the equipment for the purpose of demonstrating compliance with FCC Part 15.249. All tests were conducted using measurement procedure ANSI C63.4-1992. Radiated Emissions were made on an open area test site.

New Submission

Production Unit

Class II Permissive Change

Pre-Production Unit

E	T	S
---	---	---

Equipment Code

THIS TEST REPORT RELATES ONLY TO THE ITEM(S) TESTED.

THE FOLLOWING DEVIATIONS FROM, ADDITIONS TO, OR EXCLUSIONS FROM THE TEST SPECIFICATIONS HAVE BEEN MADE.

See " Summary of Test Data".



NVLAP LAB CODE: 100351-0

TESTED BY: _____ DATE: _____
Russell Grant, Technologist

KTL Ottawa Inc. authorizes the above named company to reproduce this report provided it is reproduced in its entirety and for use by the company's employees only.

Any use which a third party makes of this report, or any reliance on or decisions to be made based on it, are the responsibility of such third parties. KTL Ottawa Inc. accepts no responsibility for damages, if any, suffered by any third party as a result of decisions made or actions based on this report. This report applies only to the items tested.

EQUIPMENT: Sony SPP-ID970 900 MHz Cordless Telephone
FCC ID: EW780-4282-00

Summary Of Test Data

Base:

NAME OF TEST	PARA. NO.	RESULT
Conducted Emissions	15.207	Complies
Radiated Emissions	15.249	Complies

Handset:

NAME OF TEST	PARA. NO.	RESULT
Radiated Emissions	15.249	Complies

Footnotes For N/A's:

Test Conditions:

Indoor Temperature: 20 °C
 Humidity: 30 %

Outdoor Temperature: Not Applicable
 Humidity: Not Applicable

EQUIPMENT: Sony SPP-ID970 900 MHz Cordless Telephone
FCC ID: EW780-4282-00

Section 2A. General Equipment Specification

Base:

Frequency Range: 902.3 to 906.65 MHz

Tunable Bands: 1

Number of Channels: 30

Channel Spacing: 150 kHz

Emission Designator: 108K0F1D

Crystal Frequencies: 18.25 MHz Ref.

Integral Antenna **Yes** **No**

Note: If antenna is not integral to transmitter explain method of attachment and type of unique connector:

EQUIPMENT: Sony SPP-ID970 900 MHz Cordless Telephone
FCC ID: EW780-4282-00

Section 2B. General Equipment Specification

Handset

Frequency Range: 923.1 to 927.75 MHz

Tunable Bands: 1

Number of Channels: 30

Channel Spacing: 150 kHz

Emission Designator: 108K0F1D

Crystal Frequencies: 18.25 MHz Ref.

Integral Antenna **Yes** **No**

Note: If antenna is not integral to transmitter explain method of attachment and type of unique connector:

EQUIPMENT: Sony SPP-ID970 900 MHz Cordless Telephone

FCC ID: EW780-4282-00

Description of Modification for Class II Permissive Change

NOT APPLICABLE

KTL Ottawa

FCC PART 15, SUBPART C
FOR 900 MHz CORDLESS TELEPHONES
PROJECT NO.: 8R01348.1

EQUIPMENT: Sony SPP-ID970 900 MHz Cordless Telephone
FCC ID: EW780-4282-00

Modifications Made During Testing

NOT APPLICABLE

EQUIPMENT: Sony SPP-ID970 900 MHz Cordless Telephone
FCC ID: EW780-4282-00

Theory of Operation

The E.U.T. is a 900 MHz telephone and supports the following features:

- FSK Modulation
- 48 kbps
- 50 kHz pp Frequency Deviation
- Single Conversion Superhetrodyne Receiver

System Diagram

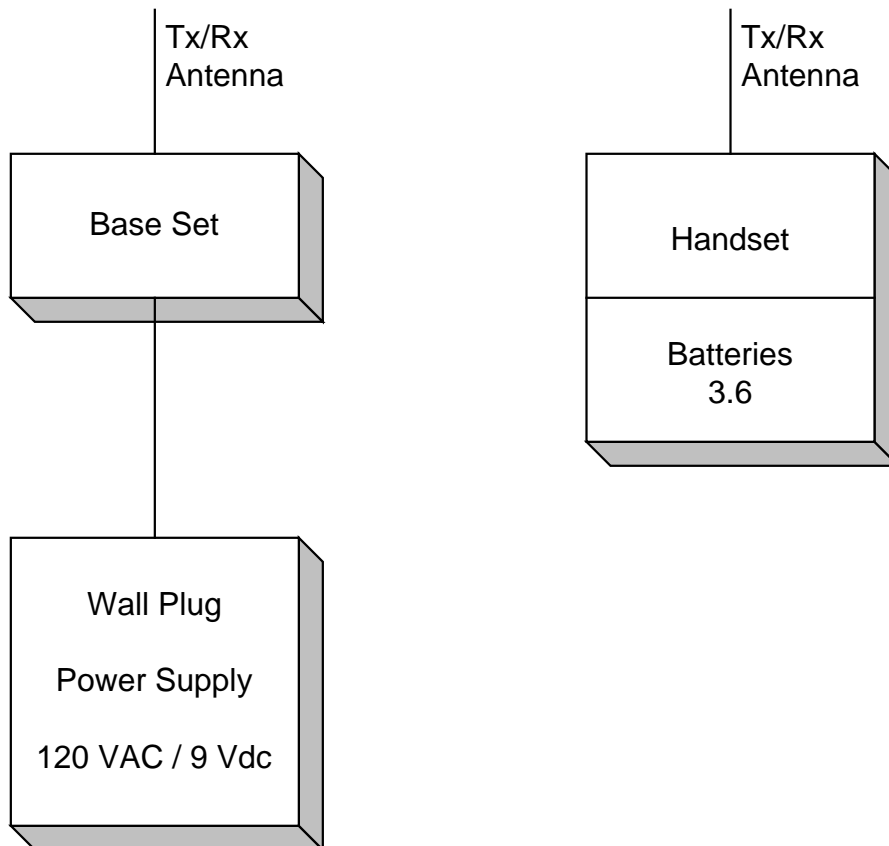

EQUIPMENT: Sony SPP-ID970 900 MHz Cordless Telephone
FCC ID: EW780-4282-00

Section 3. Powerline Conducted Emissions

NAME OF TEST: Powerline Conducted Emissions	PARA. NO.: 15.207
TESTED BY: Russell Grant	DATE: March 11, 1999

Minimum Standard:

Frequency (MHz)	Maximum Powerline Conducted RF Voltage	
	(μ V)	(dB μ V)
0.45 - 30.0	250	48

Test Results: Complies. See attached graph(s).

Measurement Data: See attached graph(s).

Method of Measurement: (Procedure ANSI C63.4-1992)

Measurements were made using a spectrum analyzer with 10 kHz RBW, Peak Detector. Any emissions that are close to the limit are measured using a test receiver with 10 kHz bandwidth, CISPR Quasi-Peak Detector.

EQUIPMENT: Sony SPP-ID970 900 MHz Cordless Telephone
FCC ID: EW780-4282-00

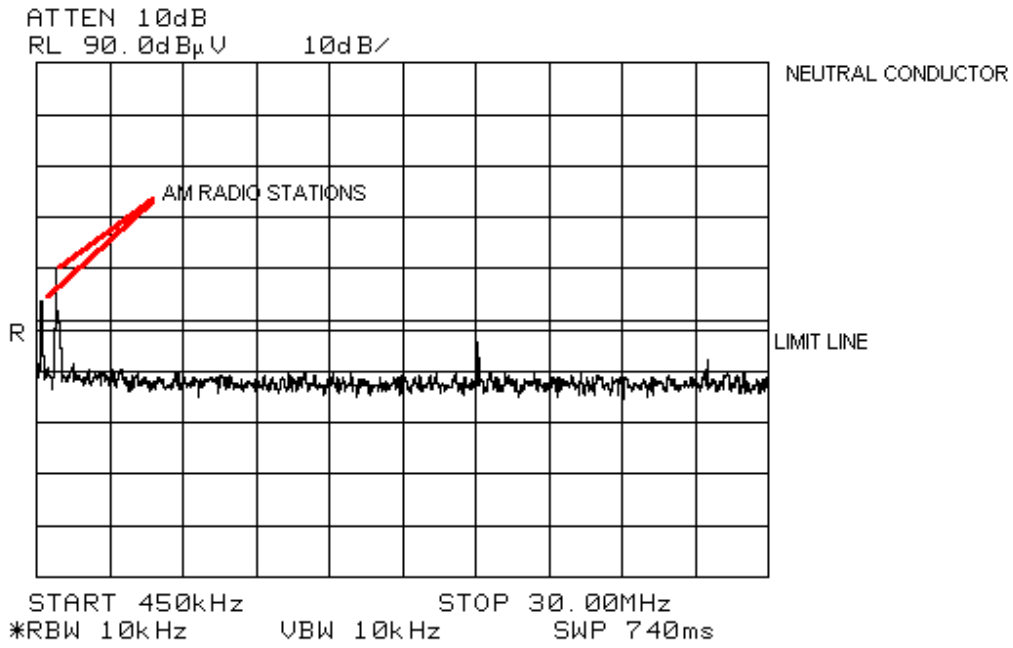

EQUIPMENT: Sony SPP-ID970 900 MHz Cordless Telephone
FCC ID: EW780-4282-00

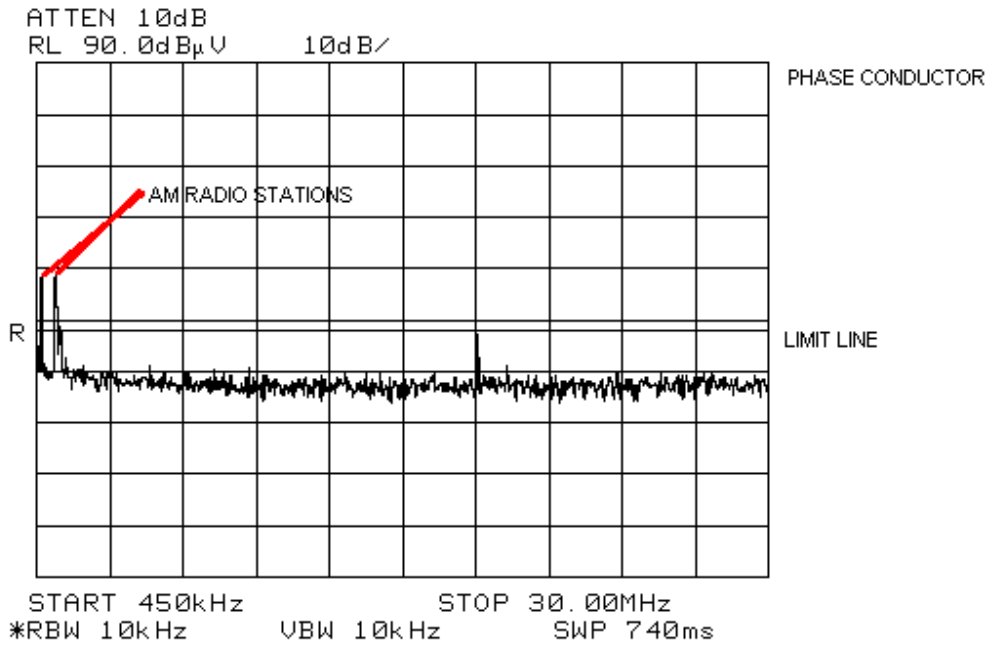

EQUIPMENT: Sony SPP-ID970 900 MHz Cordless Telephone
FCC ID: EW780-4282-00

Conducted Photographs - Base (Worst Case Configuration)

Front View



EQUIPMENT: Sony SPP-ID970 900 MHz Cordless Telephone
FCC ID: EW780-4282-00

Section 4A. Radiated Emissions (Base)

NAME OF TEST: Radiated Emissions (Base)	PARA. NO.: 15.249
TESTED BY: Russell Grant	DATE: March 11, 1999

Minimum Standard: Para no. 15.249

(a) The field strengths shall not exceed the following:

Fundamental (MHz)	Field Strength (mV/m)	Field Strength (dBµV)	Harmonic (mV/m)	Harmonic (dBµV)
902-928	50	94	0.5	54

(b) Field strength limits are specified at a distance of 3 metres.

(c) Emissions radiated outside of the specified frequency bands, except for harmonics, shall be attenuated by at least 50 dB below the level of the fundamental or to the general radiated limits of 15.209 whichever is the less attenuation.

(d) The emission limits shown above are based on measurement instrumentation employing a CISPR quasi-peak detector below 1000 MHz and an averaging detector above 1000 MHz. However, the peak field strength of any emission shall not exceed the average limit by more than 20 dB.

Test Results: Complies. The worst-case emission level is 79.9 dBµV/m @ 3m at 906.65 MHz. This is 14.1 dB above the specification limit. The spectrum was searched up to the 10th harmonic of the fundamental frequency of operation and all emissions within 20 dB of the specification limit were measured and reported.

Measurement Data: See attached table.

Maximizing Emission Levels:

For hand held equipment or equipment that may be mounted in a variety of positions, the E.U.T. was tested on three orthogonal axis to determine orientation of worst-case emission levels.

EQUIPMENT: Sony SPP-ID970 900 MHz Cordless Telephone
FCC ID: EW780-4282-00

Test Data - Radiated Emissions (Base): Tx 902.3

Test Distance (meters) : 3		Range:		Receiver:		RBW(kHz): 120		Detector:			
Freq. (MHz)	Ant. *	Pol. (V/H)	Ant. HGT. (m)	Table (deg.)	RCVD Signal (dBµV/m)	Ant. Factor (dB)**	Amp. Gain (dB)***	Dist. Corr. (dB)	Field Strength (dBµV/m)	Limit (dBµV/m)	Margin (dB)
902.3	L/P	V			48.3	30.2			78.5	94.0	15.5
902.3	L/P	H			42.3	30.2			72.5	94.0	21.5

Notes:
 B/C = Biconical, B/L = Biconilog, L/P = Log-Periodic, H = Horn, D/P = Dipole
 * Re-measured using dipole antenna.
 ** Includes cable loss when amplifier is not used.
 *** Includes cable loss.
 () Denotes failing emission level.

Test Data - Radiated Emissions (Base): Tx 904.4

Test Distance (meters) : 3		Range:		Receiver:		RBW(kHz): 120		Detector:			
Freq. (MHz)	Ant. *	Pol. (V/H)	Ant. HGT. (m)	Table (deg.)	RCVD Signal (dBµV/m)	Ant. Factor (dB)**	Amp. Gain (dB)***	Dist. Corr. (dB)	Field Strength (dBµV/m)	Limit (dBµV/m)	Margin (dB)
904.4	L/P	V			47.0	30.2			77.2	94.0	16.8
904.4	L/P	H			42.7	30.2			72.9	94.0	21.1

Notes:
 B/C = Biconical, B/L = Biconilog, L/P = Log-Periodic, H = Horn, D/P = Dipole
 * Re-measured using dipole antenna.
 ** Includes cable loss when amplifier is not used.
 *** Includes cable loss.
 () Denotes failing emission level.

Test Data - Radiated Emissions (Base): Tx 906.65

Test Distance (meters) : 3		Range:		Receiver:		RBW(kHz): 120		Detector:			
Freq. (MHz)	Ant. *	Pol. (V/H)	Ant. HGT. (m)	Table (deg.)	RCVD Signal (dBµV/m)	Ant. Factor (dB)**	Amp. Gain (dB)***	Dist. Corr. (dB)	Field Strength (dBµV/m)	Limit (dBµV/m)	Margin (dB)
906.65	L/P	V			49.7	30.2			79.9	94.0	14.1
906.65	L/P	H			44.7	30.2			74.9	94.0	19.1

Notes:
 B/C = Biconical, B/L = Biconilog, L/P = Log-Periodic, H = Horn, D/P = Dipole
 * Re-measured using dipole antenna.
 ** Includes cable loss when amplifier is not used.
 *** Includes cable loss.
 () Denotes failing emission level.

EQUIPMENT: Sony SPP-ID970 900 MHz Cordless Telephone
FCC ID: EW780-4282-00

Radiated Photographs - Base (Worst Case Configuration)

Front View

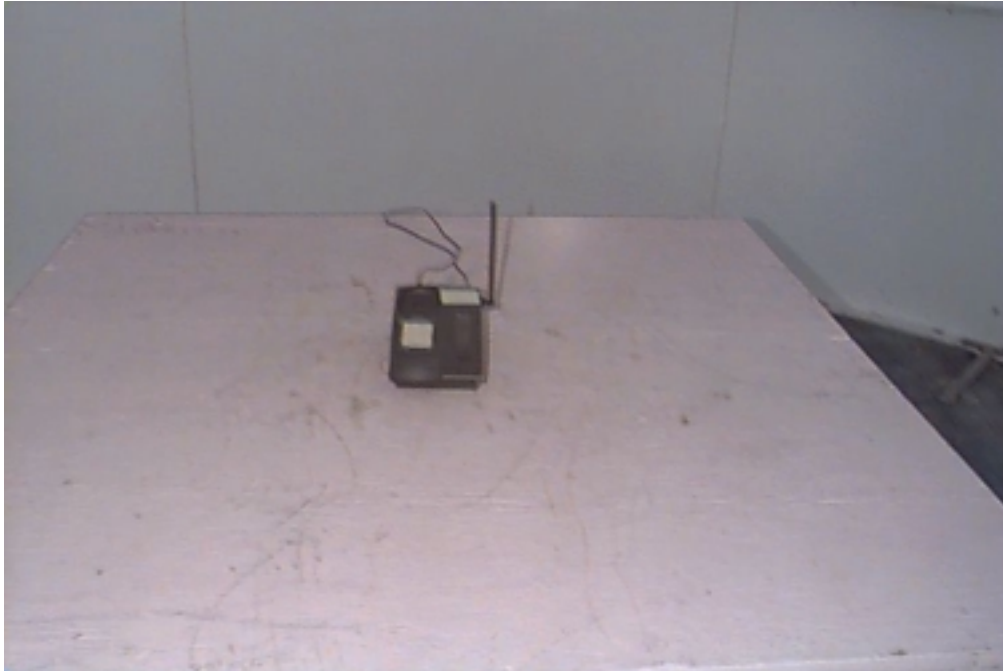

EQUIPMENT: Sony SPP-ID970 900 MHz Cordless Telephone
FCC ID: EW780-4282-00

Section 4B. Radiated Emissions (Handset)

NAME OF TEST: Radiated Emissions (Handset)	PARA. NO.: 15.249
TESTED BY: Russell Grant	DATE: March 11, 1999

Minimum Standard: Para no. 15.249

(a) The field strengths shall not exceed the following:

Fundamental (MHz)	Field Strength (mV/m)	Field Strength (dBµV)	Harmonic (mV/m)	Harmonic (dBµV)
902-928	50	94	0.5	54

(b) Field strength limits are specified at a distance of 3 metres.

(c) Emissions radiated outside of the specified frequency bands, except for harmonics, shall be attenuated by at least 50 dB below the level of the fundamental or to the general radiated limits of 15.209 whichever is the less attenuation.

(d) The emission limits shown above are based on measurement instrumentation employing a CISPR quasi-peak detector below 1000 MHz and an averaging detector above 1000 MHz. However, the peak field strength of any emission shall not exceed the average limit by more than 20 dB.

Test Results: Complies. The worst-case emission level is 86.0 dBµV/m @ 3m at 927.75MHz. This is 8.0 dB above the specification limit. The spectrum was searched up to the 10th harmonic of the fundamental frequency of operation and all emissions within 20 dB of the specification limit were measured and reported.

Measurement Data: See attached table.

Maximizing Emission Levels:

For hand held equipment or equipment that may be mounted in a variety of positions, the E.U.T. was tested on three orthogonal axis to determine orientation of worst-case emission levels.

EQUIPMENT: Sony SPP-ID970 900 MHz Cordless Telephone
FCC ID: EW780-4282-00

Test Data - Radiated Emissions (Base): Tx 923.1

Test Distance (meters) : 3		Range:		Receiver:		RBW(kHz): 120		Detector:			
Freq. (MHz)	Ant. *	Pol. (V/H)	Ant. HGT. (m)	Table (deg.)	RCVD Signal (dBµV/m)	Ant. Factor (dB)**	Amp. Gain (dB)***	Dist. Corr. (dB)	Field Strength (dBµV/m)	Limit (dBµV/m)	Margin (dB)
923.1	L/P	V		52.5	30.5				83.0	94.0	11.0
923.1	L/P	H		40.5	30.5				71.0	94.0	23.0

Notes:
 B/C = Biconical, B/L = Biconilog, L/P = Log-Periodic, H = Horn, D/P = Dipole
 * Re-measured using dipole antenna.
 ** Includes cable loss when amplifier is not used.
 *** Includes cable loss.
 () Denotes failing emission level.

Test Data - Radiated Emissions (Base): Tx 925.5

Test Distance (meters) : 3		Range:		Receiver:		RBW(kHz): 120		Detector:			
Freq. (MHz)	Ant. *	Pol. (V/H)	Ant. HGT. (m)	Table (deg.)	RCVD Signal (dBµV/m)	Ant. Factor (dB)**	Amp. Gain (dB)***	Dist. Corr. (dB)	Field Strength (dBµV/m)	Limit (dBµV/m)	Margin (dB)
925.5	L/P	V			52.7	30.7		83.4	94.0	10.6	
925.5	L/P	H			42.7	30.7		73.4	94.0	20.6	

Notes:
 B/C = Biconical, B/L = Biconilog, L/P = Log-Periodic, H = Horn, D/P = Dipole
 * Re-measured using dipole antenna.
 ** Includes cable loss when amplifier is not used.
 *** Includes cable loss.
 () Denotes failing emission level.

Test Data - Radiated Emissions (Base): Tx 927.75

Test Distance (meters) : 3		Range:		Receiver:		RBW(kHz): 120		Detector:			
Freq. (MHz)	Ant. *	Pol. (V/H)	Ant. HGT. (m)	Table (deg.)	RCVD Signal (dBµV/m)	Ant. Factor (dB)**	Amp. Gain (dB)***	Dist. Corr. (dB)	Field Strength (dBµV/m)	Limit (dBµV/m)	Margin (dB)
927.75	L/P	V			55.7	30.7			86.0	94	8.0
927.75	L/P	H			45.7	30.7			76.4	94	17.6

Notes:
 B/C = Biconical, B/L = Biconilog, L/P = Log-Periodic, H = Horn, D/P = Dipole
 * Re-measured using dipole antenna.
 ** Includes cable loss when amplifier is not used.
 *** Includes cable loss.
 () Denotes failing emission level.

EQUIPMENT: Sony SPP-ID970 900 MHz Cordless Telephone
FCC ID: EW780-4282-00

Radiated Photographs - Handset (Worst Case Configuration)

Front View

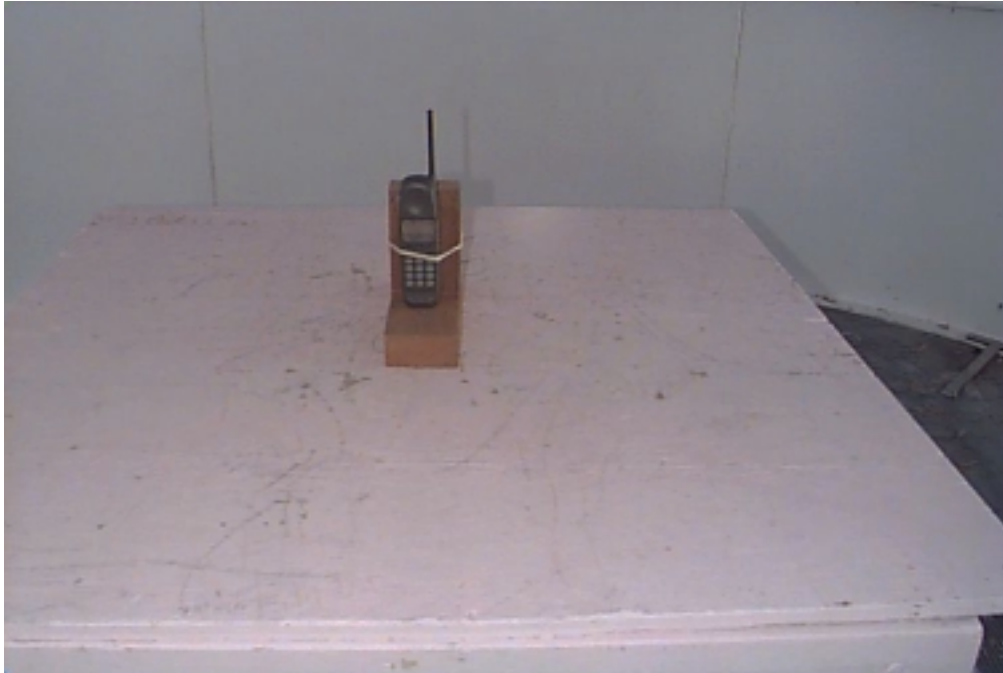

EQUIPMENT: Sony SPP-ID970 900 MHz Cordless Telephone
FCC ID: EW780-4282-00

Section 5. Test Equipment List

CAL CYCLE	EQUIPMENT	MANUFACTURER	MODEL	SERIAL	LAST CAL.	NEXT CAL.	
1 Year	Spectrum Analyzer	Hewlett Packard	8565E	FA000981	May 20/98	May 20/99	
1 Year	LISN	Tegam	95300-50	T-12855/56	July 24/98	July 24/99	
1 Year	LISN(peripheral)	Tegam	95300-50	T-109014/15	July 24/98	July 24/99	
2 Year	Horn Antenna	EMCO #2	3115	4336	Oct. 30/97	Oct. 30/99	
1 Year	Dipole Antenna Set	EMCO	3121C	1029	Oct. 28/97	Oct. 28/98	

NA: Not Applicable
NCR: No Cal Required

KTL Ottawa

FCC PART 15, SUBPART C
FOR 900 MHz CORDLESS TELEPHONES
PROJECT NO.: 8R01348.1
ANNEX A

EQUIPMENT: Sony SPP-ID970 900 MHz Cordless Telephone
FCC ID: EW780-4282-00

ANNEX A
TEST DIAGRAMS

EQUIPMENT: Sony SPP-ID970 900 MHz Cordless Telephone
FCC ID: EW780-4282-00

Conducted Emissions

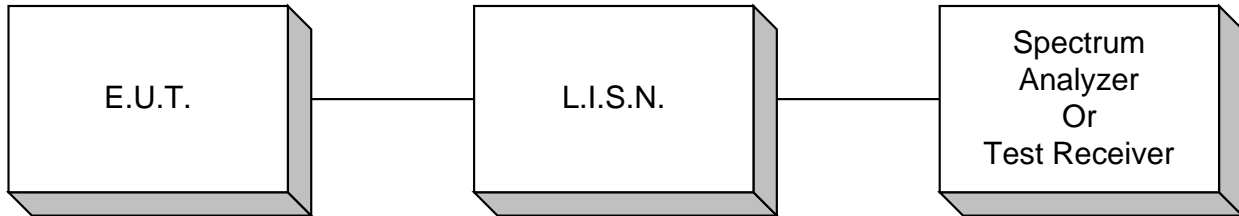

Radiated Prescan

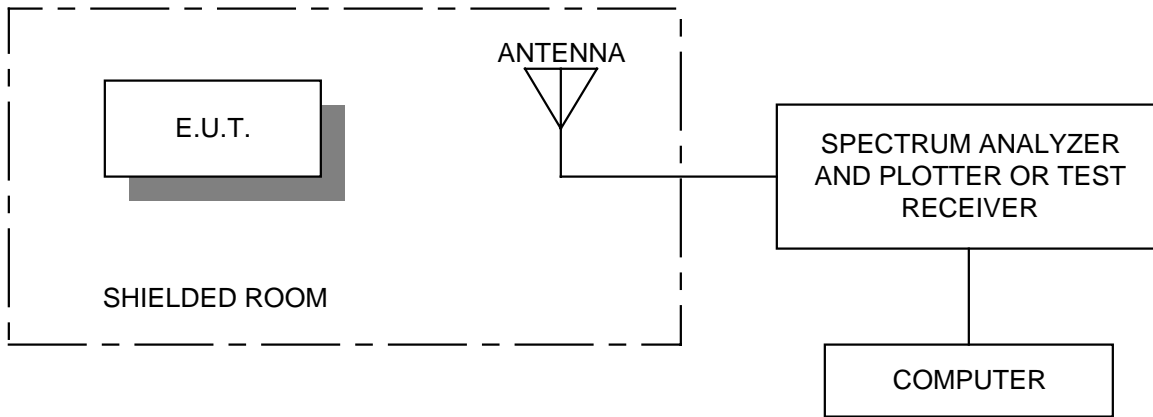

EQUIPMENT: Sony SPP-ID970 900 MHz Cordless Telephone
FCC ID: EW780-4282-00

Test Site For Radiated Emissions

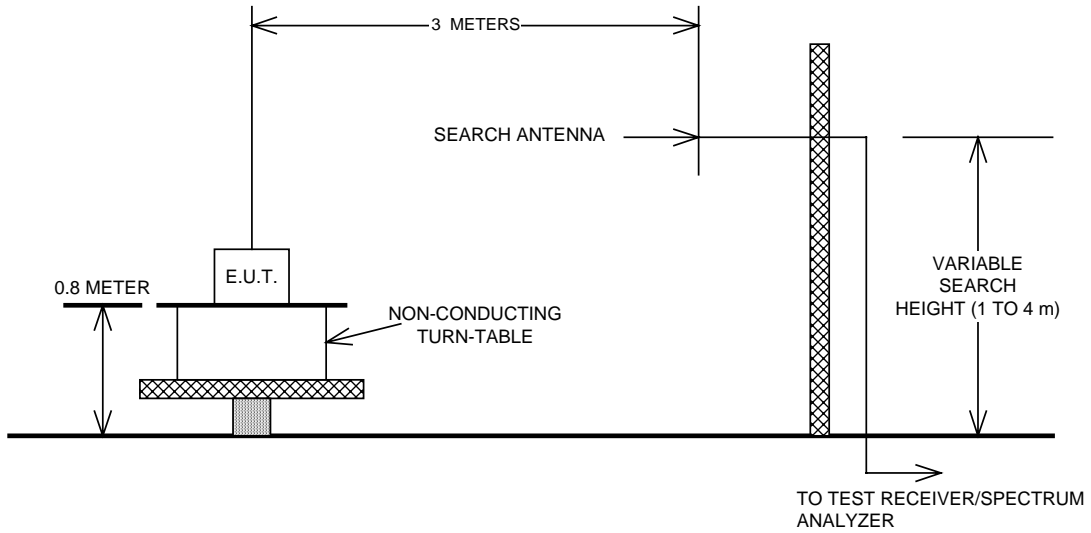

KTL Ottawa

FCC PART 15, SUBPART C
FOR 900 MHz CORDLESS TELEPHONES
PROJECT NO.: 8R01348.1
ANNEX B

EQUIPMENT: Sony SPP-ID970 900 MHz Cordless Telephone
FCC ID: EW780-4282-00

ANNEX B

RESTRICTED BANDS OF OPERATION

EQUIPMENT: Sony SPP-ID970 900 MHz Cordless Telephone
FCC ID: EW780-4282-00

Section B Restricted Bands of Operation

(a) Except as shown in paragraph (d) of this section , only spurious emissions are permitted in any of the frequency bands listed below:

MHz	MHz	MHz	GHz
0.090 - 0.110	16.42-16.423	399.9-410	4.5-5.15
0.49 - 0.51	16.69475-16.69525	608-614	5.35-5.46
2.1735 - 2.1905	16.80425-16.80475	960-1240	7.25-7.75
3.020 - 3.026	25.5-25.67	1300-1427	8.025-8.5
4.125 - 4.128	37.5-38.25	1435-1626.6	9.0-9.2
4.17725 - 4.17775	73-74.6	1645.5-1646.5	9.3-9.5
4.20725 - 4.20775	74.8-75.2	1660-1710	10.6-12.7
6.215 - 6.218	108-121.94	1718.8-1722.2	13.25-13.4
6.31175 - 6.31225	123-138	2220-2300	14.47-14.5
8.291 - 8.294	149.9-150.05	2310-2390	15.35-16.2
8.362 - 8.366	156.52475-156.52525	2483.5-2500	17.7-21.4
8.37625 - 8.38675	156.7-156.9	2655-2900	22.01-23.12
8.41425 - 8.41475	162.0125-167.17	3260-3267	23.6-24.0
12.29 - 12.293	167.72-173.2	3332-3339	31.2-31.8
12.51975 - 12.52025	240-285	3345.8-3358	36.43-36.5
12.57675 - 12.57725	322-335.4	3600-4400	Above 38.6
13.36 - 13.41			