

TEST REPORT

Applicant Name: VTech Telecommunications Ltd
Address: 23/F Tai Ping Ind Center Block 1 57 Ting Kok Rd Tai Po NT, Hong Kong
Report Number: 2401A33675E-SAA
FCC ID: EW780-3615-00

Test Standard (s)

FCC 47 CFR part 2.1093

Sample Description

Product Name: DECT 6.0 cordless telephone
Model No.: BL108-2
Multiple Model(s) No.: BL108, BL108-3, BL108-4, BL108-5, BL108-XY
Trade Mark: AT&T
Serial Number: 2VX9-2
Date Received: 2024/12/13
Date of Test: 2025/04/30
Issue Date: 2025/06/19

Test Result:

Pass▲

▲ In the configuration tested, the EUT complied with the standards above.

Prepared and Checked By:

Bob Lu

Bob Lu
SAR Engineer

Approved By:

Luke Jiang

Luke Jiang
SAR Engineer

Note: The information marked*is provided by the applicant, the laboratory is not responsible for its authenticity and this information can affect the validity of the result in the test report. Customer model name, addresses, names, trademarks etc. are included.

This report cannot be reproduced except in full, without prior written approval of the Company. Unless otherwise stated the results shown in this test report refer only to the sample(s) tested. This report is valid only with a valid digital signature. The digital signature may be available only under the Adobe software above version 7.0.

This report must not be used by the customer to claim product certification, approval, or endorsement by NVLAP or any agency of the U.S. Government.

This report may contain data that are not covered by the NVLAP accreditation and are marked with an asterisk "▼".

Bay Area Compliance Laboratories Corp. (Shenzhen)

5F(B-West), 6F, 7F, the 3rd Phase of Wan Li Industrial Building D, Shihua Rd, Futian Free Trade Zone, Shenzhen, China
Tel: +86-755-33320018 Fax: +86-755-33320008 www.baclcorp.com.cn

Attestation of Test Results		
MODE	Max. SAR Level(s) Reported(W/kg)	Limit (W/kg)
DECT	1g Head SAR	0.04
	1g Body SAR	0.04
Applicable Standards	FCC 47 CFR part 2.1093 Radio frequency radiation exposure evaluation: portable devices	
	RF Exposure Procedures: TCB Workshop April 2019	
	IEEE 1528:2013 IEEE Recommended Practice for Determining the Peak Spatial-Average Specific Absorption Rate (SAR) in the Human Head from Wireless Communications Devices: Measurement Techniques	
	KDB procedures KDB 447498 D01 General RF Exposure Guidance v06 KDB 648474 D04 Handset SAR v01r03 KDB 865664 D01 SAR Measurement 100 MHz to 6 GHz v01r04 KDB 865664 D02 RF Exposure Reporting v01r02	
<p>Note: This wireless device has been shown to be capable of compliance for localized specific absorption rate (SAR) for General Population/Uncontrolled Exposure limits specified in FCC 47 CFR part 2.1093 and has been tested in accordance with the measurement procedures specified in IEEE 1528-2013 and RF exposure KDB procedures.</p> <p>The results and statements contained in this report pertain only to the device(s) evaluated.</p>		

TABLE OF CONTENTS

DOCUMENT REVISION HISTORY.....	4
EUT DESCRIPTION	5
TECHNICAL SPECIFICATION.....	5
REFERENCE, STANDARDS, AND GUIDELINES	6
SAR LIMITS	6
FACILITIES.....	7
DESCRIPTION OF TEST SYSTEM.....	8
EQUIPMENT LIST AND CALIBRATION.....	15
EQUIPMENT’S LIST & CALIBRATION INFORMATION.....	15
SAR MEASUREMENT SYSTEM VERIFICATION	16
LIQUID VERIFICATION.....	16
SYSTEM ACCURACY VERIFICATION	17
SAR SYSTEM VALIDATION DATA	18
EUT TEST STRATEGY AND METHODOLOGY.....	19
TEST POSITIONS FOR DEVICE OPERATING NEXT TO A PERSON’S EAR	19
CHEEK/TOUCH POSITION	20
EAR/TILT POSITION.....	20
TEST POSITIONS FOR BODY-WORN AND OTHER CONFIGURATIONS	21
TEST DISTANCE FOR SAR EVALUATION	21
SAR EVALUATION PROCEDURE	22
CONDUCTED OUTPUT POWER MEASUREMENT	23
TEST PROCEDURE.....	23
DESCRIPTION OF TEST CONFIGURATION	23
EQUIPMENT MODIFICATIONS	23
MAXIMUM TARGET OUTPUT POWER.....	23
TEST RESULTS.....	24
STANDALONE SAR TEST EXCLUSION CONSIDERATIONS.....	25
ANTENNAS LOCATION:	25
STANDALONE SAR TEST EXCLUSION CONSIDERATIONS	25
SAR MEASUREMENT RESULTS	26
TEST RESULTS:.....	26
SAR MEASUREMENT VARIABILITY.....	27
SAR DUT HOLDER PERTURBATIONS	28
SAR SIMULTANEOUS TRANSMISSION DESCRIPTION.....	29
SAR PLOTS	30
APPENDIX A MEASUREMENT UNCERTAINTY	40
APPENDIX B EUT TEST POSITION PHOTOS.....	41
LIQUID DEPTH ≥ 15CM.....	41
HEAD LEFT CHEEK SETUP PHOTO (0 MM)	42
HEAD LEFT TILT SETUP PHOTO (0 MM).....	42
HEAD RIGHT CHEEK SETUP PHOTO (0 MM).....	43
HEAD RIGHT TILT SETUP PHOTO (0 MM).....	43
BODY FRONT SETUP PHOTO (0 MM)	44
BODY BACK SETUP PHOTO (0 MM)	44
APPENDIX C CALIBRATION CERTIFICATES.....	45
APPENDIX D RETURN LOSS&IMPEDANCE MEASUREMENT	61

DOCUMENT REVISION HISTORY

Revision Number	Report Number	Description of Revision	Date of Revision
0	2401A33675E-SAA	Original Report	2025/06/19

EUT DESCRIPTION

This report has been prepared on behalf of **VTech Telecommunications Ltd** and their product **DECT 6.0 cordless telephone**, Model: **BL108-2, BL108, BL108-3, BL108-4, BL108-5, BL108-XY**, Test Model: **BL108-2**, FCC ID: **EW780-3615-00** or the EUT (Equipment under Test) as referred to in the rest of this report.

**All measurement and test data in this report was gathered from production sample serial number:2VX9-2(Assigned by BACL, Shenzhen). The EUT supplied by the applicant was received on 2024/12/13.*

Technical Specification

Product Type:	Portable
Exposure Category:	Population / Uncontrolled
Antenna Type(s):	Internal Antenna
Body-Worn Accessories:	None
Operation modes:	DECT
Frequency Band:	DECT: 1921.536-1928.448MHz
Maximum Conducted Peak Output Power:	DECT: 19.66 dBm
Antenna Specification[#]:	DECT: 0 dBi (provided by the applicant)
Dimensions (L×W×H):	188 × 51 × 22 mm (All models are the same size)
Rated Input Voltage:	Battery 1(GREPOW): DC 1.2V, 400mAh Ni-MH Battery 2(CR1724): DC 1.2V, 400mAh Ni-MH Battery 3(GP0325): DC 1.2V, 400mAh Ni-MH Battery 4 (HP2430): DC 1.2V, 400mAh Ni-MH
Normal Operation:	Head and Body
<p>Note:</p> <ol style="list-style-type: none"> The Multiple models are electrically identical with the test model except for color, model number, package type, no. of handset and charger. Please refer to the declaration letter[#] for more detail, which was provided by manufacturer. Battery 1 was selected to test all items. The parameters of the four batteries are the same except for the manufacturer; therefore, worst-case verification is unnecessary. 	

REFERENCE, STANDARDS, AND GUIDELINES

FCC:

The Report and Order requires routine SAR evaluation prior to equipment authorization of portable transmitter devices, including portable telephones. For consumer products, the applicable limit is 1.6 mW/g as recommended by the ANSI/IEEE standard C95.1-1992 [6] for an uncontrolled environment (Paragraph 65). According to the Supplement C of OET Bulletin 65 "Evaluating Compliance with FCC Guide-lines for Human Exposure to Radio frequency Electromagnetic Fields", released on Jun 29, 2001 by the FCC, the device should be evaluated at maximum output power (radiated from the antenna) under "worst-case" conditions for normal or intended use, incorporating normal antenna operating positions, device peak performance frequencies and positions for maximum RF energy coupling.

This report describes the methodology and results of experiments performed on wireless data terminal. The objective was to determine if there is RF radiation and if radiation is found, what is the extent of radiation with respect to safety limits. SAR (Specific Absorption Rate) is the measure of RF exposure determined by the amount of RF energy absorbed by human body (or its parts) – to determine how the RF energy couples to the body or head which is a primary health concern for body worn devices. The limit below which the exposure to RF is considered safe by regulatory bodies in North America is 1.6 mW/g average over 1 gram of tissue mass.

SAR Limits

FCC Limit (1g Tissue)

EXPOSURE LIMITS	SAR (W/kg)	
	(General Population / Uncontrolled Exposure Environment)	(Occupational / Controlled Exposure Environment)
Spatial Average (averaged over the whole body)	0.08	0.4
Spatial Peak (averaged over any 1 g of tissue)	1.6	8.0
Spatial Peak (hands/wrists/feet/ankles averaged over 10 g)	4.0	20.0

Population/Uncontrolled Environments are defined as locations where there is the exposure of individual who have no knowledge or control of their exposure.

Occupational/Controlled Environments are defined as locations where there is exposure that maybe incurred by people who are aware of the potential for exposure (i.e. as a result of employment or occupation).

General Population/Uncontrolled environments Spatial Peak limit 1.6W/kg for 1g SAR applied to the EUT.

FACILITIES

The test site used by Bay Area Compliance Laboratories Corp. (Shenzhen) to collect data is located at 5F(B-West) ,6F,7F,the 3rd Phase of Wan Li Industrial Building D,Shihua Rd, FuTian Free Trade Zone, Shenzhen, China

The lab has been recognized as the FCC accredited lab under the KDB 974614 D01 and is listed in the FCC Public Access Link (PAL) database, FCC Registration No.: 715558, the FCC Designation No.: CN5045.

Each test item follows test standards and with no deviation.

DESCRIPTION OF TEST SYSTEM

These measurements were performed with the automated near-field scanning system DASY6 from Schmid & Partner Engineering AG (SPEAG) which is the Fifth generation of the system shown in the figure hereinafter:

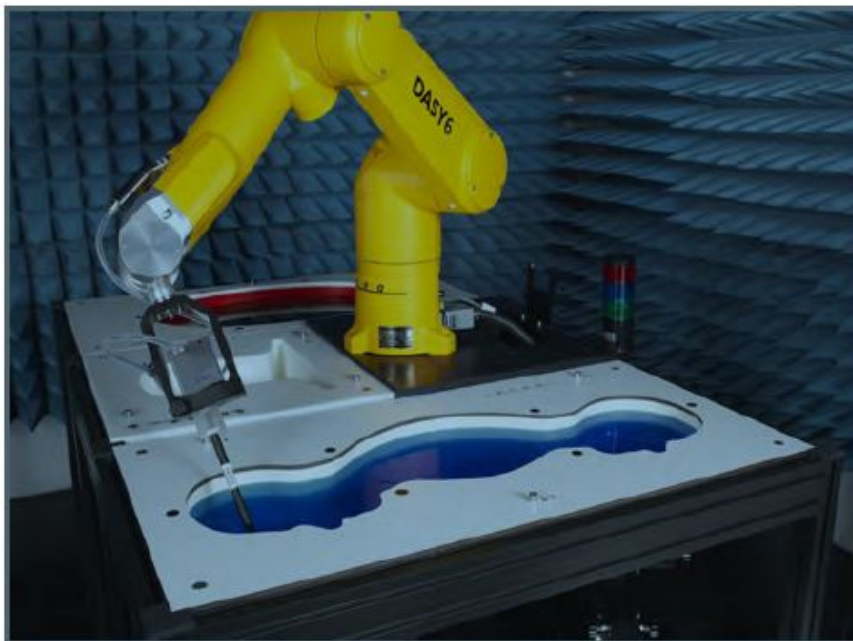

DASY6 System Description

The DASY6 system for performing compliance tests consists of the following items:

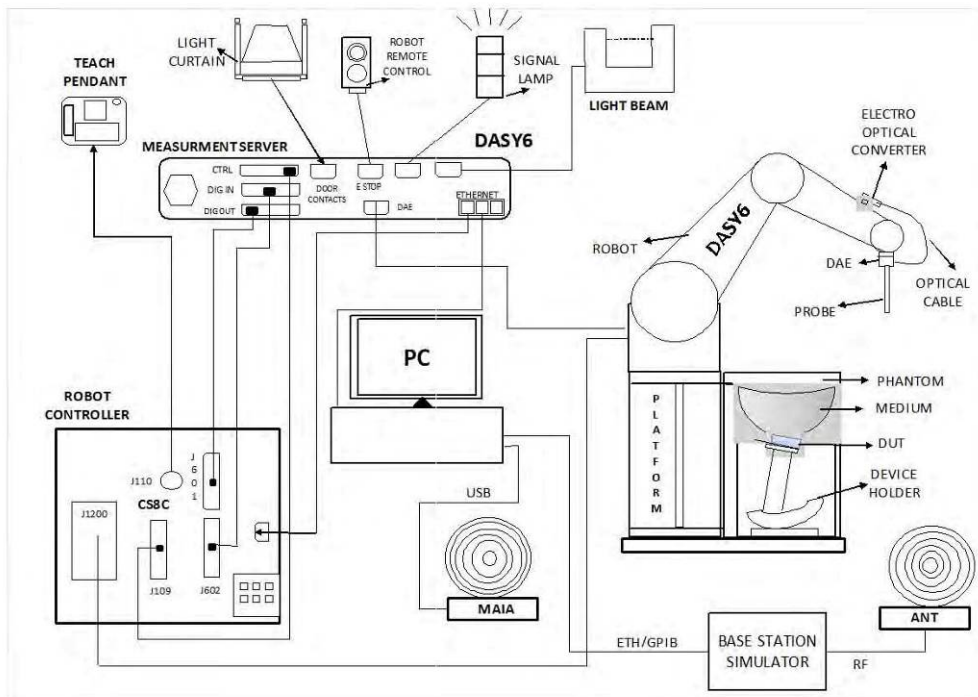

- A standard high precision 6-axis robot (Staubli TX=RX family) with controller, teach pendant and software. An arm extension for accommodating the data acquisition electronics (DAE).
- An isotropic field probe optimized and calibrated for the targeted measurement.
- A data acquisition electronics (DAE) which performs the signal application, signal multiplexing, AD-conversion, offset measurements, mechanical surface detection, collision detection, etc. The unit is battery powered with standard or rechargeable batteries. The signal is optically transmitted to the EOC.
- The Electro-optical converter (EOC) performs the conversion from optical to electrical signals for the digital communication to the DAE. To use optical surface detection, a special version of the EOC is required. The EOC signal is transmitted to the measurement server.
- The function of the measurement server is to perform the time critical tasks such as signal filtering, control of the robot operation and fast movement interrupts.
- The Light Beam used is for probe alignment. This improves the (absolute) accuracy of the probe positioning.
- A computer running Win7 professional operating system and the DASY52 software.
- Remote control and teach pendant as well as additional circuitry for robot safety such as warning lamps, etc.
- The phantom, the device holder and other accessories according to the targeted measurement.

DASY6 Measurement Server

The DASY6 measurement server is based on a PC/104 CPU board with a 400 MHz Intel ULV Celeron, 128 MB chip-disk and 128 MB RAM. The necessary circuits for communication with the DAE4 (or DAE3) electronics box, as well as the 16-bit AD converter system for optical detection and digital I/O interface are contained on the DASY6 I/O board, which is directly connected to the PC/104 bus of the CPU board.



The measurement server performs all real-time data evaluations of field measurements and surface detection, controls robot movements, and handles safety operations. The PC operating system cannot interfere with these time-critical processes. All connections are supervised by a watchdog, and disconnection of any of the cables to the measurement server will automatically disarm the robot and disable all program-controlled robot movements. Furthermore, the measurement server is equipped with an expansion port, which is reserved for future applications. Please note that this expansion port does not have a standardized pinout, and therefore only devices provided by SPEAG can be connected. Connection of devices from any other supplier could seriously damage the measurement server.

Data Acquisition Electronics

The data acquisition electronics (DAE4) consist of a highly sensitive electrometer-grade preamplifier with auto-zeroing, a channel and gain-switching multiplexer, a fast 16 bit AD-converter and a command decoder with a control logic unit. Transmission to the measurement server is accomplished through an optical downlink for data and status information, as well as an optical uplink for commands and the clock.

The mechanical probe mounting device includes two different sensor systems for frontal and sideways probe contacts. They are used for mechanical surface detection and probe collision detection.

The input impedance of both the DAE4 as well as of the DAE3 box is 200M Ω ; the inputs are symmetrical and floating. Common mode rejection is above 80 dB.

EX3DV4 E-Field Probes

Frequency	4 MHz to >10 GHz Linearity: ± 0.2 dB (30 MHz to 10 GHz)
Directivity	± 0.1 dB in TSL (rotation around probe axis) ± 0.3 dB in TSL (rotation normal to probe axis)
Dynamic Range	10 µW/g to > 100 mW/g Linearity: ± 0.2 dB (noise: typically < 1 µW/g)
Dimensions	Overall length: 337 mm (Tip: 20 mm) Tip diameter: 2.5 mm (Body: 12 mm) Typical distance from probe tip to dipole centers: 1 mm
Application	High precision dosimetric measurements in any exposure scenario (e.g., very strong gradient fields); the only probe that enables compliance testing for frequencies up to 6 GHz with precision of better 30%.
Compatibility	DASY3, DASY4, DASY52 SAR and higher, EASY6, EASY4/MRI

SAM Twin Phantom

The SAM Twin Phantom (shown in front of DASY6) is a fiberglass shell phantom with shell thickness 2 mm, except in the ear region where the thickness is increased to 6 mm. The phantom has three measurement areas: 1) Left Head, 2) Right Head, and 3) Flat Section. For larger devices, the use of the ELI-Phantom (shown behind DASY6) is required. For devices such as glasses with a wireless link, the Face Down Phantom is the most suitable (between the SAM Twin and ELI phantoms).

When the phantom is mounted inside allocated slot of the DASY6 platform, phantom reference points can be taught directly in the DASY5 V5.2 software. When the DASY6 platform is used to mount the

Phantom, some of the phantom teaching points cannot be reached by the robot in DASY5 V5.2. A special tool called P1a-P2aX-Former is provided to transform two of the three points, P1 and P2, to reachable locations. To use these new teaching points, a revised phantom configuration file is required.

In addition to our standard broadband liquids, the phantom can be used with the following tissue simulating liquids:

Sugar-water-based liquids can be left permanently in the phantom. Always cover the liquid when the system is not in use to prevent changes in liquid parameters due to water evaporation.

DGBE-based liquids should be used with care. As DGBE is a softener for most plastics, the liquid should be taken out of the phantom, and the phantom should be dried when the system is not in use (desirable at least once a week).

Do not use other organic solvents without previously testing the solvent resistivity of the phantom. Approximately 25 liters of liquid is required to fill the SAM Twin phantom.

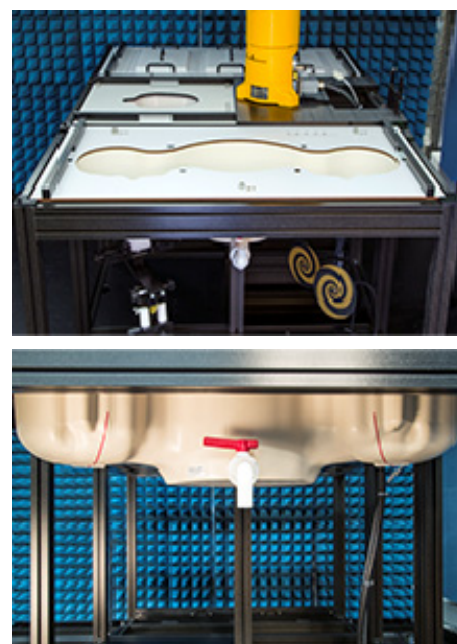

ELI Phantom

The ELI phantom is intended for compliance testing of handheld and body-mounted wireless devices in the frequency range of 30MHz to 6 GHz. ELI is fully compatible with the latest draft of the standard IEEE 1528 and the use of all known tissue simulating liquids. ELI has been optimized for performance and can be integrated into a SPEAG standard phantom table. A cover is provided to prevent evaporation of water and changes in liquid parameters. Reference markings on the phantom allow installation of the complete setup, including all predefined phantom positions and measurement grids, by teaching three points.

The phantom can be used with the following tissue simulating liquids:

- Sugar-water-based liquids can be left permanently in the phantom. Always cover the liquid when the system is not in use to prevent changes in liquid parameters due to water evaporation.
- DGBE-based liquids should be used with care. As DGBE is a softener for most plastics, the liquid should be taken out of the phantom, and the phantom should be dried when the system is not in use (desirable at least once a week).
- Do not use other organic solvents without previously testing the solvent resistivity of the phantom.

Approximately 25 liters of liquid is required to fill the ELI phantom.

Robots

The DASY6 system uses the high-precision industrial robots TX60L, TX90XL, and RX160L from Staubli SA (France). The TX robot family - the successor of the well-known RX robot family - continues to offer the features important for DASY6 applications:

- High precision (repeatability 0.02mm)
- High reliability (industrial design)
- Low maintenance costs (virtually maintenance free due to direct drive gears; no belt drives)
- Jerk-free straight movements (brushless synchrony motors; no stepper motors)
- Low ELF interference (motor control fields shielded via the closed metallic construction shields)

The robots are controlled by the Staubli CS8c robot controllers. All information regarding the use and maintenance of the robot arm and the robot controller is provided

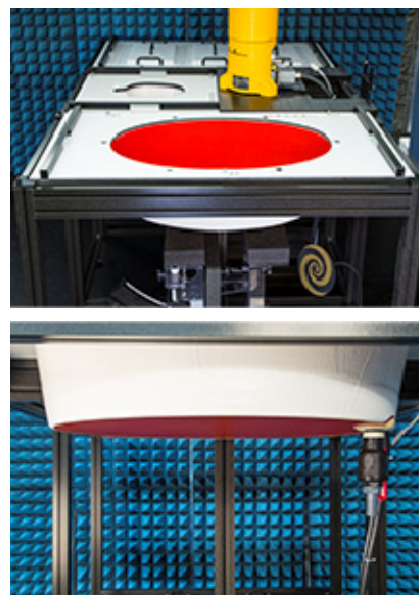

Calibration Frequency Points for EX3DV4 E-Field Probes SN: 7896 Calibrated: 2024/11/07

Calibration Frequency Point (MHz)	Frequency Range (MHz)		Conversion Factor		
	From	To	X	Y	Z
750 Head	650	810	8.72	9.14	9.15
900 Head	810	1000	8.08	8.47	8.48
1750 Head	1650	1810	7.20	7.55	7.56
1900 Head	1810	2000	6.96	7.29	7.30
2300 Head	2200	2399	6.79	7.12	7.13
2450 Head	2399	2500	6.54	6.85	6.86
2600 Head	2500	2700	6.60	6.92	6.93
3300 Head	3200	3400	5.83	6.12	6.12
3500 Head	3400	3600	5.91	6.19	6.20
3700 Head	3600	3800	5.92	6.20	6.21
3900 Head	3800	4000	5.79	6.07	6.07
5250 Head	5140	5360	4.86	5.09	5.09
5600 Head	5490	5700	4.52	4.74	4.74
5800 Head	5700	5900	4.56	4.78	4.78
6500 Head	5900	7200	4.74	4.96	4.97

SAR Scan Procedures

Step 1: Power Reference Measurement

The Power Reference Measurement and Power Drift Measurements are for monitoring the power drift of the device under test in the batch process. The minimum distance of probe sensors to surface determines the closest measurement point to phantom surface. The minimum distance of probe sensors to surface is 1.4 mm. This distance cannot be smaller than the distance of sensor calibration points to probe tip as defined in the probe properties.

Step 2: Area Scans

Area scans are defined prior to the measurement process being executed with a user defined variable spacing between each measurement point (integral) allowing low uncertainty measurements to be conducted. Scans defined for FCC applications utilize a 15mm² step integral, with 1.5mm interpolation used to locate the peak SAR area used for zoom scan assessments.

Where the system identifies multiple SAR peaks (which are within 25% of peak value) the system will provide the user with the option of assessing each peak location individually for zoom scan averaging.

Area Scan Parameters extracted from KDB 865664 D01 SAR Measurement 100 MHz to 6 GHz

	≤ 3 GHz	> 3 GHz
Maximum distance from closest measurement point (geometric center of probe sensors) to phantom surface	5 mm ± 1 mm	$\frac{1}{2} \cdot \delta \cdot \ln(2)$ mm ± 0.5 mm
Maximum probe angle from probe axis to phantom surface normal at the measurement location	30° ± 1°	20° ± 1°
Maximum area scan spatial resolution: ΔX_{Area} , ΔY_{Area}	≤ 2 GHz: ≤ 15 mm 2 – 3 GHz: ≤ 12 mm	3 – 4 GHz: ≤ 12 mm 4 – 6 GHz: ≤ 10 mm
	When the x or y dimension of the test device, in the measurement plane orientation, is smaller than the above, the measurement resolution must be ≤ the corresponding x or y dimension of the test device with at least one measurement point on the test device.	

Step 3: Zoom Scan (Cube Scan Averaging)

The averaging zoom scan volume utilized in the DASY5 software is in the shape of a cube and the side dimension of a 1 g or 10 g mass is dependent on the density of the liquid representing the simulated tissue. A density of 1000 kg/m³ is used to represent the head and body tissue density and not the phantom liquid density, in order to be consistent with the definition of the liquid dielectric properties, i.e. the side length of the 1g cube is 5mm, with the side length of the 10g cube is 21.5mm.

Zoom Scan Parameters extracted from KDB 865664 D01 SAR Measurement 100 MHz to 6 GHz

Maximum zoom scan spatial resolution: $\Delta x_{Zoom}, \Delta y_{Zoom}$		≤ 2 GHz: ≤ 8 mm 2 – 3 GHz: ≤ 5 mm*	3 – 4 GHz: ≤ 5 mm* 4 – 6 GHz: ≤ 4 mm*
Maximum zoom scan spatial resolution, normal to phantom surface	uniform grid: $\Delta z_{Zoom}(n)$	≤ 5 mm	3 – 4 GHz: ≤ 4 mm 4 – 5 GHz: ≤ 3 mm 5 – 6 GHz: ≤ 2 mm
	graded grid	$\Delta z_{Zoom}(1)$: between 1 st two points closest to phantom surface	≤ 4 mm
		$\Delta z_{Zoom}(n>1)$: between subsequent points	$\leq 1.5 \cdot \Delta z_{Zoom}(n-1)$ mm
Minimum zoom scan volume	x, y, z	≥ 30 mm	3 – 4 GHz: ≥ 28 mm 4 – 5 GHz: ≥ 25 mm 5 – 6 GHz: ≥ 22 mm
<p>Note: δ is the penetration depth of a plane-wave at normal incidence to the tissue medium; see IEEE Std 1528-2013 for details.</p> <p>* When zoom scan is required and the <i>reported</i> SAR from the <i>area scan based 1-g SAR estimation</i> procedures of KDB Publication 447498 is ≤ 1.4 W/kg, ≤ 8 mm, ≤ 7 mm and ≤ 5 mm zoom scan resolution may be applied, respectively, for 2 GHz to 3 GHz, 3 GHz to 4 GHz and 4 GHz to 6 GHz.</p>			

Step 4: Power Drift Measurement

The Power Drift Measurement measures the field at the same location as the most recent power reference measurement within the same procedure, and with the same settings. The Power Drift Measurement gives the field difference in dB from the reading conducted within the last Power Reference Measurement. This allows a user to monitor the power drift of the device under test within a batch process. The measurement procedure is the same as Step 1.

When the cube intersects with the surface of the phantom, it is oriented so that 3 vertices touch the surface of the shell or the center of a face is tangent to the surface. The face of the cube closest to the surface is modified in order to conform to the tangent surface.

The zoom scan integer steps can be user defined so as to reduce uncertainty, but normal practice for typical test applications (including FCC) utilize a physical step of 7 x 7 x 7 (5mm x 5mm x 5mm) providing a volume of 30 mm in the X & Y & Z axis.

Tissue Dielectric Parameters for Head and Body Phantoms

The head tissue dielectric parameters recommended by the IEEE 1528:2013

Recommended Tissue Dielectric Parameters for Head liquid

Table A.3 – Dielectric properties of the head tissue-equivalent liquid

Frequency MHz	Relative permittivity ϵ_r	Conductivity (σ) S/m
300	45,3	0,87
450	43,5	0,87
<i>750</i>	<i>41,9</i>	<i>0,89</i>
835	41,5	0,90
900	41,5	0,97
1 450	40,5	1,20
<i>1 500</i>	<i>40,4</i>	<i>1,23</i>
<i>1 640</i>	<i>40,2</i>	<i>1,31</i>
<i>1 750</i>	<i>40,1</i>	<i>1,37</i>
1 800	40,0	1,40
1 900	40,0	1,40
2 000	40,0	1,40
<i>2 100</i>	<i>39,8</i>	<i>1,49</i>
<i>2 300</i>	<i>39,5</i>	<i>1,67</i>
2 450	39,2	1,80
<i>2 600</i>	<i>39,0</i>	<i>1,96</i>
3 000	38,5	2,40
<i>3 500</i>	<i>37,9</i>	<i>2,91</i>
<i>4 000</i>	<i>37,4</i>	<i>3,43</i>
<i>4 500</i>	<i>36,8</i>	<i>3,94</i>
<i>5 000</i>	<i>36,2</i>	<i>4,45</i>
<i>5 200</i>	<i>36,0</i>	<i>4,66</i>
<i>5 400</i>	<i>35,8</i>	<i>4,86</i>
<i>5 600</i>	<i>35,5</i>	<i>5,07</i>
<i>5 800</i>	<i>35,3</i>	<i>5,27</i>
<i>6 000</i>	<i>35,1</i>	<i>5,48</i>

NOTE For convenience, permittivity and conductivity values at those frequencies which are not part of the original data provided by Drossos et al. [33] or the extension to 5 800 MHz are provided (i.e. the values shown *in italics*). These values were linearly interpolated between the values in this table that are immediately above and below these values, except the values at 6 000 MHz that were linearly extrapolated from the values at 3 000 MHz and 5 800 MHz.

EQUIPMENT LIST AND CALIBRATION

Equipment's List & Calibration Information

Equipment	Model	S/N	Calibration Date	Calibration Due Date
DASY5 Test Software	DASY52 52.10.4	N/A	NCR	NCR
DASY6 Measurement Server	DASY6 6.0.31	N/A	NCR	NCR
Data Acquisition Electronics	DAE4	1325	2024/10/08	2025/10/07
Dosimetric E-field Probes	EX3DV4	7896	2024/11/07	2025/11/06
Mounting Device	MD4HHTV5	SD 000 H01 KA	NCR	NCR
SAM Twin Phantom	SAM-Twin V8.0	1962	NCR	NCR
Dipole, 1900MHz	D1900V2	5d231	2023/02/17	2026/02/16
Simulated Tissue Liquid Head	HBBL600-10000V6	2200808-2	Each Time	/
Network Analyzer	E5071C	SER MY46519680	2025/04/29	2026/04/28
Dielectric Assessment Kit	DAK-3.5	1248	NCR	NCR
MXG Analog Signal Generator	N5181A	MY48180408	2024/12/04	2025/12/03
USB wideband power sensor	U2021XA	MY52350001	2025/04/29	2026/04/28
Directional Coupler	855673	3307	NCR	NCR
20dB Attenuator	2	BH9879	NCR	NCR
RF Power Amplifier	5205FE	1014	NCR	NCR
Digital Radio Communication Tester	CMD60	830553/018	2025/04/29	2026/04/28
Thermometer	DTM3000	N/A	2024/12/10	2025/12/09
Temperature & Humidity Meter	10316377	N/A	2024/12/10	2025/12/09
Spectrum Analyzer	FSU26	200982	2024/09/20	2025/09/19
Straight Steel Ruler	600mm	N/A	2024/12/11	2027/12/10
Power Splitter	PD2	2000-600	2024/06/27	2025/06/26

Note:

NCR: No Calibration Required.

The Dipole calibration methods and procedures used were as detailed in:

FCC KDB Publication Number: "KDB865664 D01 SAR Measurement 100 MHz to 6 GHz"

1. The return-loss does not deviate more than 20% from the previous measurement and meets the required 20dB minimum return-loss requirement.
2. The measurement of real or imaginary parts of impedance does not deviate more than 5Ω from the previous measurement.
3. The verify result is on APPENDIX D.

SAR MEASUREMENT SYSTEM VERIFICATION

Liquid Verification

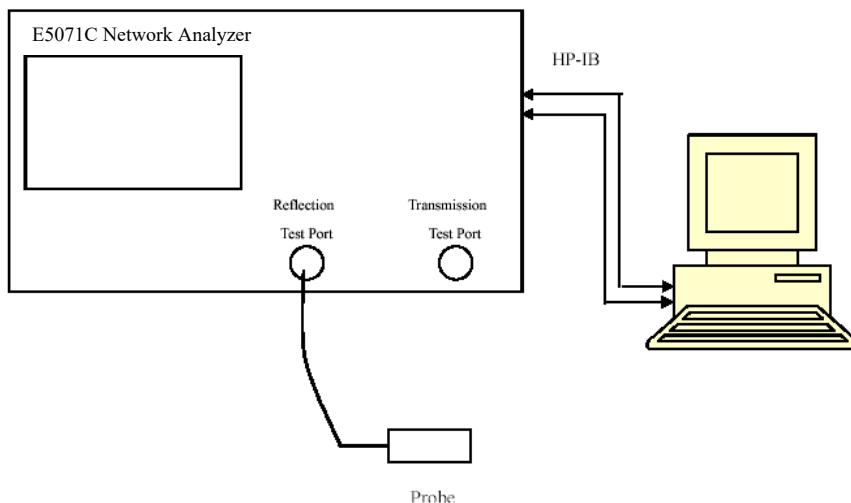

Liquid Verification Setup Block Diagram

Liquid Verification Results

Frequency (MHz)	Liquid Type	Liquid Parameter		Target Value		Delta (%)		Tolerance (%)
		ϵ_r	σ (S/m)	ϵ_r	σ (S/m)	$\Delta\epsilon_r$	$\Delta\sigma$ (S/m)	
1900	Simulated Tissue Liquid Head	40.295	1.407	40.00	1.40	0.74	0.50	±5
1921.54	Simulated Tissue Liquid Head	40.273	1.407	40.00	1.40	0.68	0.50	±5
1924.99	Simulated Tissue Liquid Head	40.269	1.407	40.00	1.40	0.67	0.50	±5
1928.45	Simulated Tissue Liquid Head	40.266	1.407	40.00	1.40	0.66	0.50	±5

*Liquid Verification above was performed on 2025/04/30.

System Accuracy Verification

Prior to the assessment, the system validation kit was used to test whether the system was operating within its specifications of $\pm 10\%$. The validation results are tabulated below. And also the corresponding SAR plot is attached as well in the SAR plots files.

The spacing distances in the **System Verification Setup Block Diagram** is given by the following:

- a) $s = 15 \text{ mm} \pm 0,2 \text{ mm}$ for $300 \text{ MHz} \leq f \leq 1 \text{ 000 MHz}$;
- b) $s = 10 \text{ mm} \pm 0,2 \text{ mm}$ for $1 \text{ 000 MHz} < f \leq 3 \text{ 000 MHz}$;
- c) $s = 10 \text{ mm} \pm 0,2 \text{ mm}$ for $3 \text{ 000 MHz} < f \leq 6 \text{ 000 MHz}$.

System Verification Setup Block Diagram

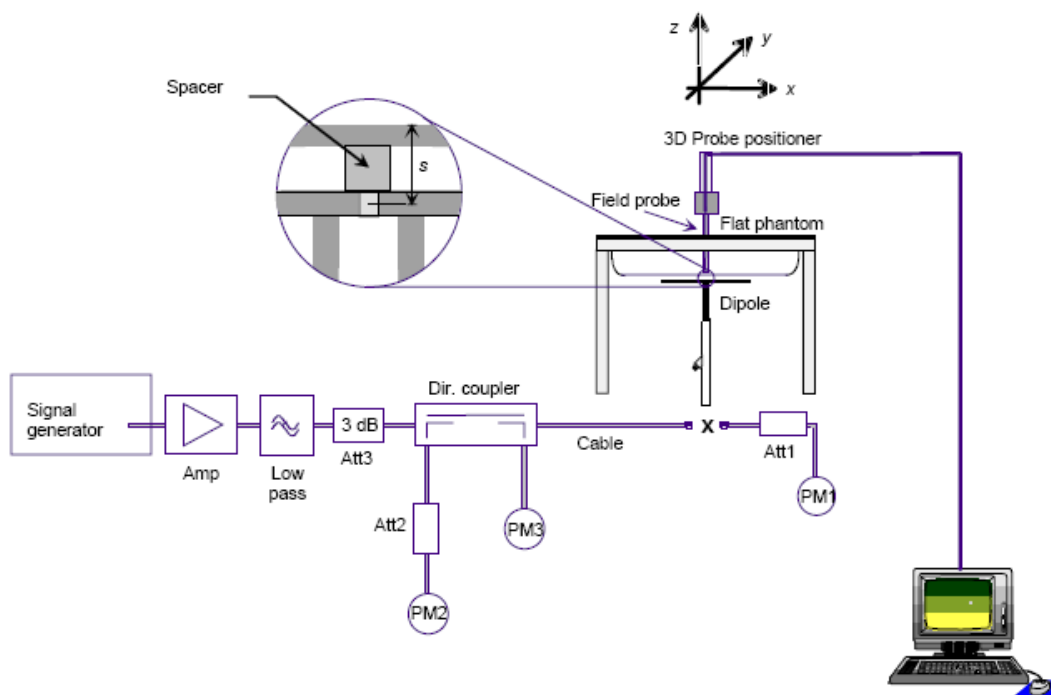

System Accuracy Check Results

Date	Frequency Band (MHz)	Liquid Type	Liquid Temperature (°C)	Input Power (mW)	Measured SAR (W/kg)	Normalized to 1W (W/kg)	Target Value (W/Kg)	Delta (%)	Tolerance (%)
2025/04/30	1900	Head	18.4 ~ 20.3	100	1g 3.89	38.9	39.9	-2.506	± 10

Note: All the SAR values are normalized to 1Watt forward power.

SAR SYSTEM VALIDATION DATA

System Performance 1900 MHz Head

DUT: Dipole 1900 MHz; Type: D1900V2; Serial: 5d231

Communication System: UID 0, CW (0); Frequency: 1900 MHz;Duty Cycle: 1:1

Medium parameters used: f = 1900 MHz; $\sigma = 1.407$ S/m; $\epsilon_r = 40.295$; $\rho = 1000$ kg/m³

Phantom section: Flat Section

DASY5 Configuration:

- Probe: EX3DV4 - SN7896; ConvF(6.96, 7.29, 7.3) @ 1900 MHz; Calibrated: 11/7/2024
- Sensor-Surface: 1.4mm (Mechanical Surface Detection)
- Electronics: DAE4 Sn1325; Calibrated: 10/8/2024
- Phantom: SAM-Twin V8.0 P1aP2a; Type: QD 000 P41 AA ;
- Measurement SW: DASY52, Version 52.10 (4); SEMCAD X Version 14.6.14 (7501)

Configuration/Head 1900MHz Pin=100mW/Area Scan (9x13x1): Measurement grid: dx=10mm, dy=10mm

Maximum value of SAR (measured) = 6.03 W/kg

Configuration/Head 1900MHz Pin=100mW/Zoom Scan (7x7x7)/Cube 0: Measurement grid: dx=5mm, dy=5mm, dz=5mm

Reference Value = 60.23 V/m; Power Drift = -0.13 dB

Peak SAR (extrapolated) = 6.38 W/kg

SAR(1 g) = 3.89 W/kg; SAR(10 g) = 2.18 W/kg

Smallest distance from peaks to all points 3 dB below = 10 mm

Ratio of SAR at M2 to SAR at M1 = 62%

Maximum value of SAR (measured) = 5.64 W/kg

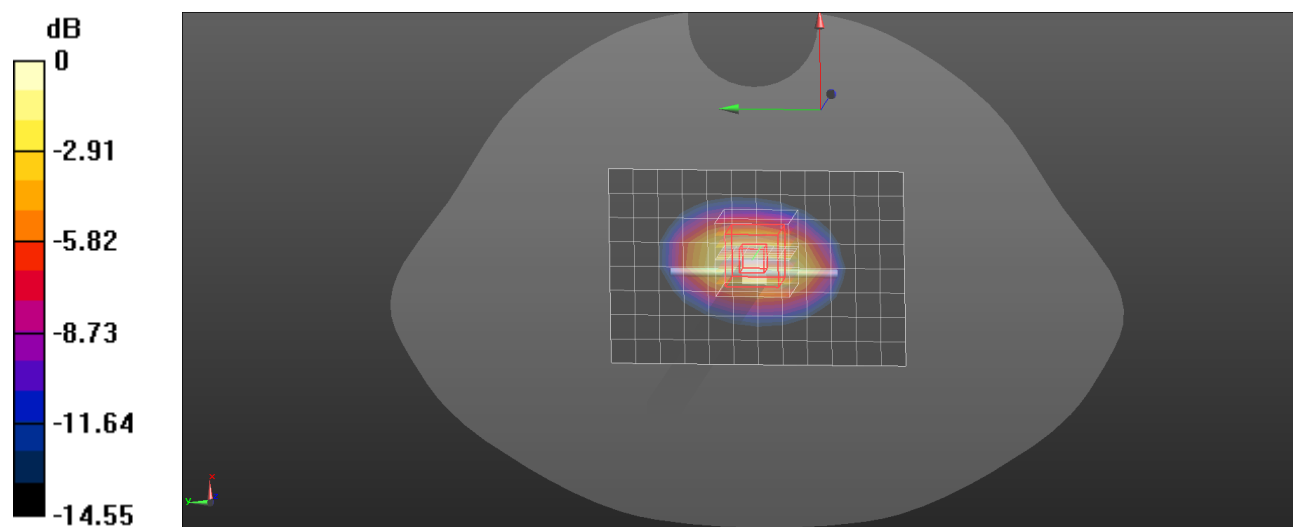

0 dB = 5.64 W/kg = 7.51 dBW/kg

EUT TEST STRATEGY AND METHODOLOGY

Test Positions for Device Operating Next to a Person’s Ear

This category includes most wireless handsets with fixed, retractable or Internal Antennas located toward the top half of the device, with or without a foldout, sliding or similar keypad cover. The handset should have its earpiece located within the upper ¼ of the device, either along the centerline or off-centered, as perceived by its users. This type of handset should be positioned in a normal operating position with the “test device reference point” located along the “vertical centerline” on the front of the device aligned to the “ear reference point”. The “test device reference point” should be located at the same level as the center of the earpiece region. The “vertical centerline” should bisect the front surface of the handset at its top and bottom edges. A “ear reference point” is located on the outer surface of the head phantom on each ear spacer. It is located 1.5 cm above the center of the ear canal entrance in the “phantom reference plane” defined by the three lines joining the center of each “ear reference point” (left and right) and the tip of the mouth.

A handset should be initially positioned with the earpiece region pressed against the ear spacer of a head phantom. For the SCC-34/SC-2 head phantom, the device should be positioned parallel to the “N-F” line defined along the base of the ear spacer that contains the “ear reference point”. For interim head phantoms, the device should be positioned parallel to the cheek for maximum RF energy coupling. The “test device reference point” is aligned to the “ear reference point” on the head phantom and the “vertical centerline” is aligned to the “phantom reference plane”. This is called the “initial ear position”. While maintaining these three alignments, the body of the handset is gradually adjusted to each of the following positions for evaluating SAR:

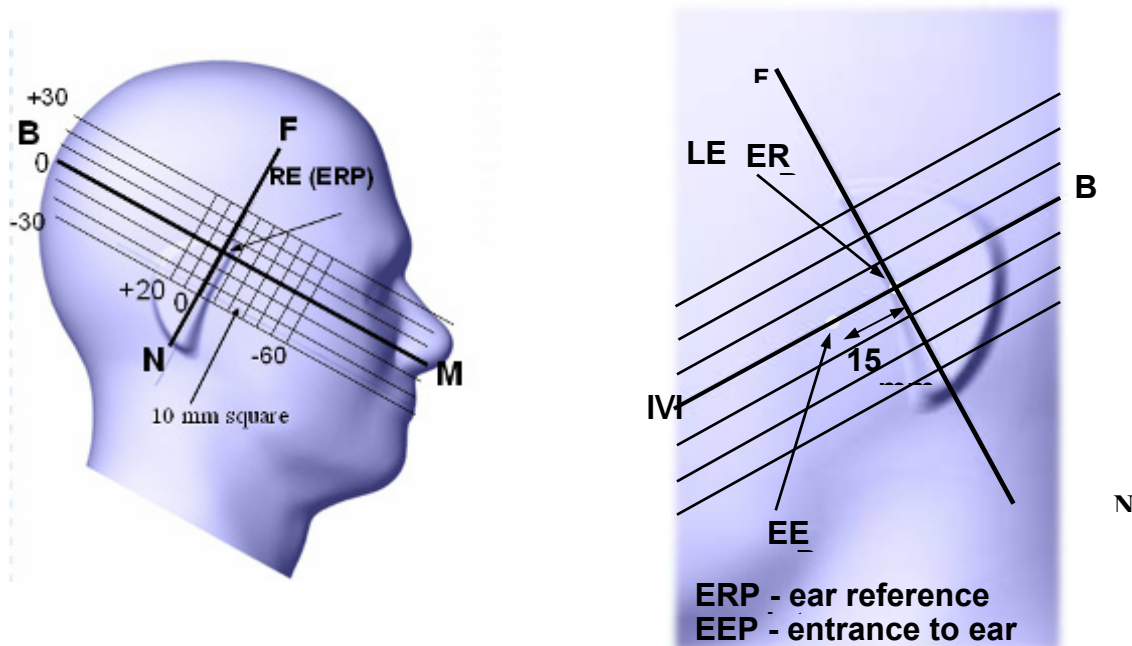

Cheek/Touch Position

The device is brought toward the mouth of the head phantom by pivoting against the “ear reference point” or along the “N-F” line for the SCC-34/SC-2 head phantom.

This test position is established:

When any point on the display, keypad or mouthpiece portions of the handset is in contact with the phantom.

(or) When any portion of a foldout, sliding or similar keypad cover opened to its intended self-adjusting normal use position is in contact with the cheek or mouth of the phantom.

For existing head phantoms – when the handset loses contact with the phantom at the pivoting point, rotation should continue until the device touches the cheek of the phantom or breaks its last contact from the ear spacer.

Cheek /Touch Position

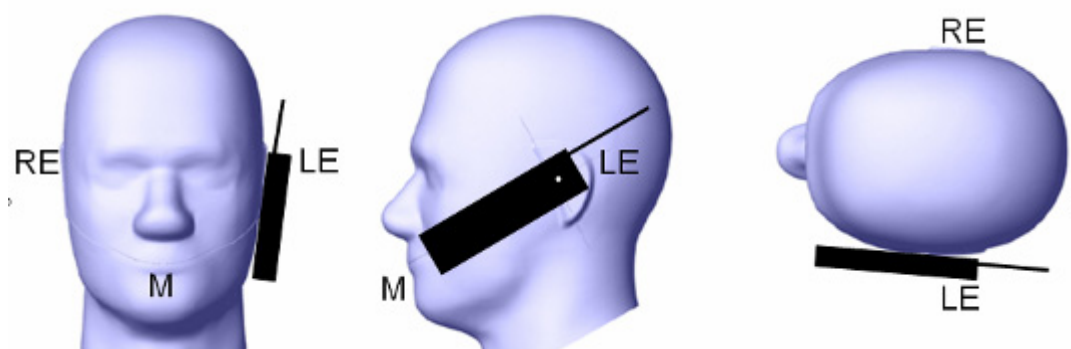

Ear/Tilt Position

With the handset aligned in the “Cheek/Touch Position”:

1) If the earpiece of the handset is not in full contact with the phantom’s ear spacer (in the “Cheek/Touch position”) and the peak SAR location for the “Cheek/Touch” position is located at the ear spacer region or corresponds to the earpiece region of the handset, the device should be returned to the “initial ear position” by rotating it away from the mouth until the earpiece is in full contact with the ear spacer.

2) (otherwise) The handset should be moved (translated) away from the cheek perpendicular to the line passes through both “ear reference points” (note: one of these ear reference points may not physically exist on a split head model) for approximate 2-3 cm. While it is in this position, the device handset is tilted away from the mouth with respect to the “test device reference point” until the inside angle between the vertical centerline on the front surface of the phone and the horizontal line passing through the ear reference point is by 15° to 80° . After the tilt, it is then moved (translated) back toward the head perpendicular to the line passes through both “ear reference points” until the device touches the phantom or the ear spacer. If the antenna touches the head first, the positioning process should be repeated with a tilt angle less than 15° so that the device and its antenna would touch the phantom simultaneously. This test position may require a device holder or positioner to achieve the translation and tilting with acceptable positioning repeatability.

If a device is also designed to transmit with its keypad cover closed for operating in the head position, such positions should also be considered in the SAR evaluation. The device should be tested on the left and right side of the head phantom in the “Cheek/Touch” and “Ear/Tilt” positions. When applicable, each configuration should be tested with the antenna in its fully extended and fully retracted positions. These test configurations should be tested at the high, middle and low frequency channels of each operating mode; for example, AMPS, CDMA, and TDMA. If the SAR measured at the middle channel for each test configuration (left, right, Cheek/Touch, Tilt/Ear, extended and retracted) is at least 2.0 dB lower than the SAR limit, testing at the high and low channels is optional for such test configuration(s). If the transmission band of the test device is less than 10 MHz, testing at the high and low frequency channels is optional.

Ear /Tilt 15° Position

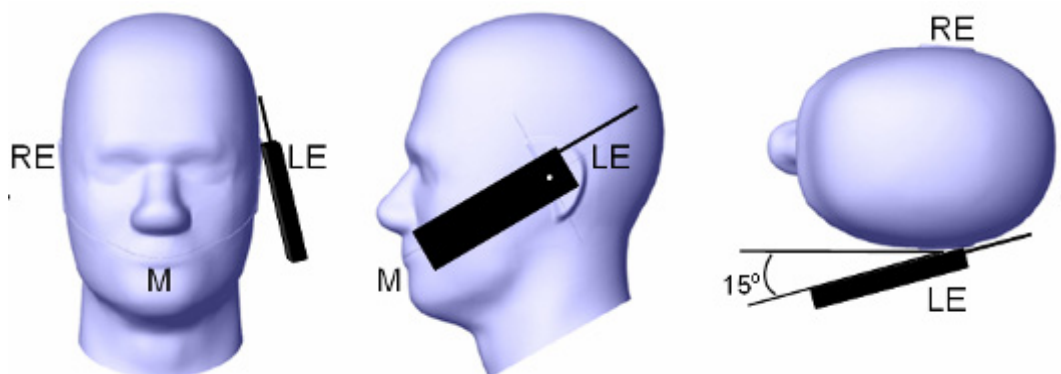

Test positions for body-worn and other configurations

Body-worn operating configurations should be tested with the belt-clips and holsters attached to the device and positioned against a flat phantom in normal use configurations. Devices with a headset output should be tested with a headset connected to the device. When multiple accessories that do not contain metallic components are supplied with the device, the device may be tested with only the accessory that dictates the closest spacing to the body. When multiple accessories that contain metallic components are supplied with the device, the device must be tested with each accessory that contains a unique metallic component. If multiple accessories share an identical metallic component (e.g., the same metallic belt-clip used with different holsters with no other metallic components), only the accessory that dictates the closest spacing to the body must be tested.

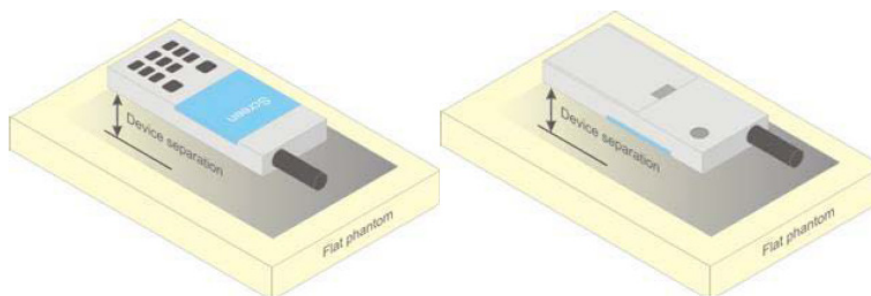

Figure 5 – Test positions for body-worn devices

Test Distance for SAR Evaluation

In this case the EUT (Equipment Under Test) is set directly against the phantom, the Body SAR test distance is 0 mm.

SAR Evaluation Procedure

The evaluation was performed with the following procedure:

- Step 1: Measurement of the SAR value at a fixed location above the ear point or central position was used as a reference value for assessing the power drop. The SAR at this point is measured at the start of the test and then again at the end of the testing.
- Step 2: The SAR distribution at the exposed side of the head was measured at a distance of 4 mm from the inner surface of the shell. The area covered the entire dimension of the head or radiating structures of the EUT, the horizontal grid spacing was 15 mm x 15 mm, and the SAR distribution was determined by integrated grid of 1.5mm x 1.5mm. Based on these data, the area of the maximum absorption was determined by spline interpolation. The first Area Scan covers the entire dimension of the EUT to ensure that the hotspot was correctly identified.
- Step 3: Around this point, a volume of 30 mm x 30 mm x 30 mm was assessed by measuring 7x 7 x 7 points. On the basis of this data set, the spatial peak SAR value was evaluated under the following procedure:
- 1) The data at the surface were extrapolated, since the center of the dipoles is 1.2 mm away from the tip of the probe and the distance between the surface and the lowest measuring point is 1.3 mm. The extrapolation was based on a least square algorithm. A polynomial of the fourth order was calculated through the points in z-axes. This polynomial was then used to evaluate the points between the surface and the probe tip.
 - 2) The maximum interpolated value was searched with a straightforward algorithm. Around this maximum the SAR values averaged over the spatial volumes (1 g or 10 g) were computed by the 3D-Spline interpolation algorithm. The 3D-Spline is composed of three one dimensional splines with the "Not a knot"-condition (in x, y and z-directions). The volume was integrated with the trapezoidal-algorithm. One thousand points (10 x 10 x 10) were interpolated to calculate the averages.
- All neighboring volumes were evaluated until no neighboring volume with a higher average value was found.
- Step 4: Re-measurement of the SAR value at the same location as in Step 1. If the value changed by more than 5%, the evaluation was repeated.

CONDUCTED OUTPUT POWER MEASUREMENT

Test Procedure

The RF output of the transmitter was connected to the input of the Spectrum Analyzer Tester.

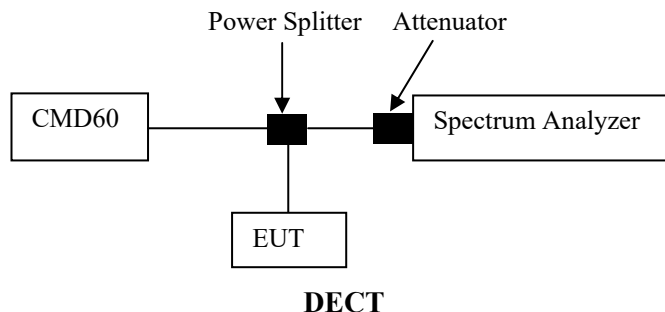

Description of Test Configuration

The system was configured to testing mode which is provided by the manufacturer.

Equipment Modifications

No modification was made to the EUT tested.

Maximum Target Output Power

Max Target Power(dBm)			
Mode/Band	Channel		
	Low	Middle	High
DECT	20.0	20.0	20.0

Test Results

DECT:

Mode	Frequency (MHz)	RF Output Peak Power (dBm)
DECT	1921.536	19.27
	1924.992	19.66
	1928.448	19.34

Note:

1. Rohde & Schwarz Radio Communication Tester (CMD60) was used for the measurement of DECT peak output power.
2. Duty Cycle=1:25.97 (0.0385).
3. The EUT belongs to a low duty cycle device.
4. Per KDB 447498 D01, **1 Channel** shall be tested; the middle channel was selected to test:

$$N_c = Round \left\{ \left[100 \left(\frac{f_{high} - f_{low}}{f_c} \right) \right]^{0.5} \times \left(\frac{f_c}{100} \right)^{0.2} \right\},$$

where

- N_c is the number of test channels, rounded to the nearest integer,
- f_{high} and f_{low} are the highest and lowest channel frequencies within the transmission band,
- f_c is the mid-band channel frequency,
- all frequencies are in MHz.

At the same time, we chose the worst mode to carry out additional testing on other channels.

Duty Cycle

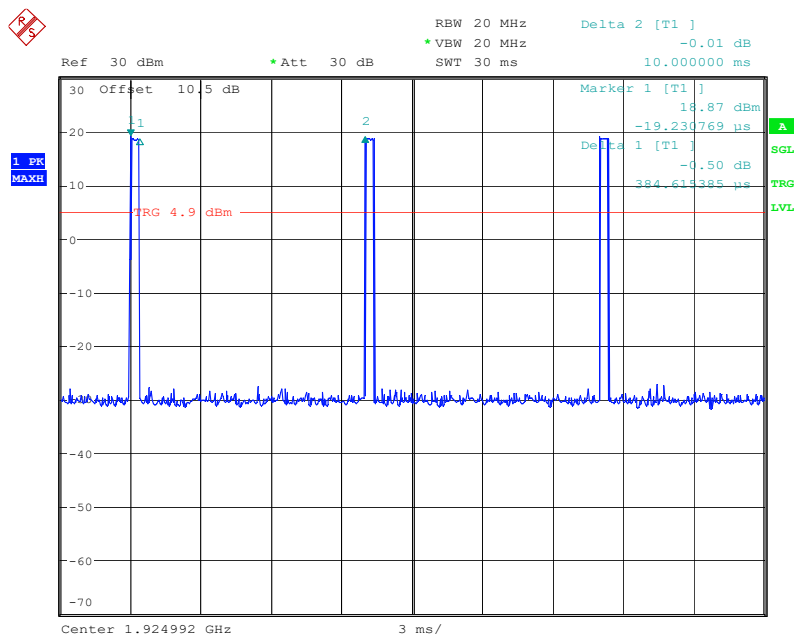

ProjectNo.:2401A33675E-RF-PP Tester:Rainbow Zhu
 Date: 22.APR.2025 11:26:54

STANDALONE SAR TEST EXCLUSION CONSIDERATIONS

Antennas Location:

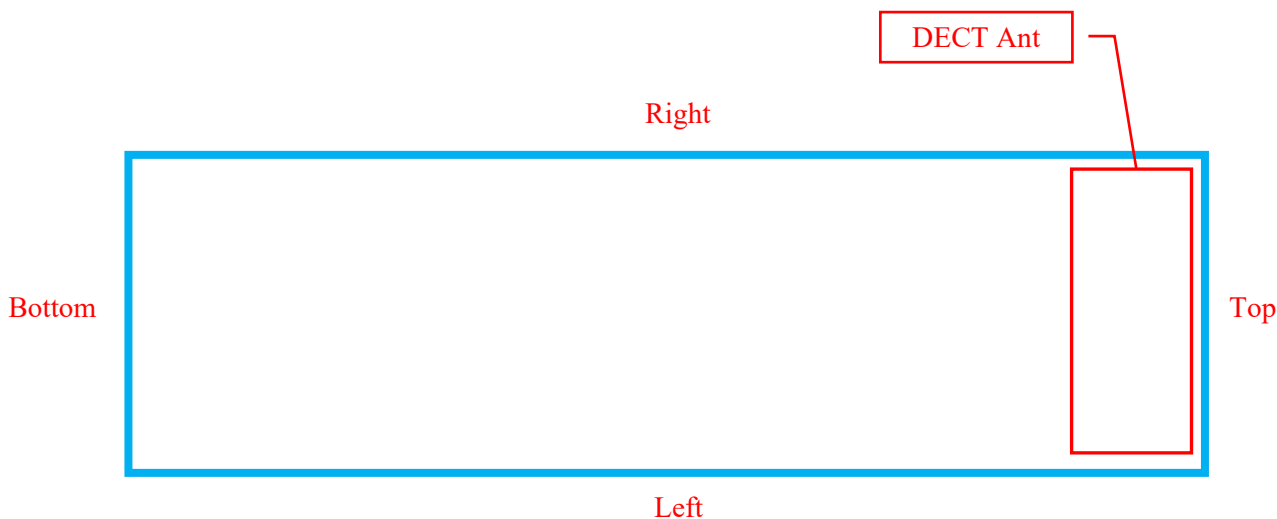

EUT Back View

Standalone SAR test exclusion considerations

Mode	Frequency (MHz)	Max Target Power (dBm)	Max Target Power (mW)	Distance (mm)	Calculated value	Threshold (1-g)	SAR Test Exclusion
DECT	1928.448	20.0	100.00	0	27.8	3	No

NOTE:

The 1-g and 10-g SAR test exclusion thresholds for 100 MHz to 6 GHz at test separation distances ≤ 50 mm are determined by:

$$[(\text{max. power of channel, including tune-up tolerance, mW}) / (\text{min. test separation distance, mm})] \cdot$$

$$[\sqrt{f(\text{GHz})}] \leq 3.0 \text{ for 1-g SAR and } \leq 7.5 \text{ for 10-g extremity SAR, where}$$

1. f(GHz) is the RF channel transmit frequency in GHz.
2. Power and distance are rounded to the nearest mW and mm before calculation.
3. The result is rounded to one decimal place for comparison.
4. When the minimum test separation distance is < 5 mm, a distance of 5 mm is applied to determine SAR test Exclusion.

SAR MEASUREMENT RESULTS

This page summarizes the results of the performed dosimetry evaluation.

Test Results:

Environmental Conditions:

Ambient Temperature:	20.7 ~ 22.2°C
Relative Humidity:	47 ~ 57%
ATM Pressure:	100.4 kPa
Test Date:	2025/04/30

* Testing was performed by Calvin.

DECT Mode:

EUT Position	Frequency (MHz)	Test Mode	Max. Meas. Power (dBm)	Max. Rated Power (dBm)	1g SAR (W/Kg)				
					Scaled Factor	Meas. SAR	Scaled SAR	Limit	Plot
Head Left Cheek	1921.536	DECT	/	/	/	/	/	1.6	/
	1924.992	DECT	19.66	20.0	1.081	0.020	0.03	1.6	1#
	1928.448	DECT	/	/	/	/	/	1.6	/
Head Left Tilt	1921.536	DECT	/	/	/	/	/	1.6	/
	1924.992	DECT	19.66	20.0	1.081	0.012	0.02	1.6	2#
	1928.448	DECT	/	/	/	/	/	1.6	/
Head Right Cheek	1921.536	DECT	19.27	20.0	1.183	0.027	0.04	1.6	3#
	1924.992	DECT	19.66	20.0	1.081	0.028	0.03	1.6	4#
	1928.448	DECT	19.34	20.0	1.164	0.026	0.04	1.6	5#
Head Right Tilt	1921.536	DECT	/	/	/	/	/	1.6	/
	1924.992	DECT	19.66	20.0	1.081	0.013	0.02	1.6	6#
	1928.448	DECT	/	/	/	/	/	1.6	/
Body Front (0 mm)	1921.536	DECT	19.27	20.0	1.183	0.028	0.04	1.6	7#
	1924.992	DECT	19.66	20.0	1.081	0.032	0.04	1.6	8#
	1928.448	DECT	19.34	20.0	1.164	0.027	0.04	1.6	9#
Body Back (0 mm)	1921.536	DECT	/	/	/	/	/	1.6	/
	1924.992	DECT	19.66	20.0	1.081	0.017	0.02	1.6	10#
	1928.448	DECT	/	/	/	/	/	1.6	/

Note:

1. When the 1-g SAR is $\leq 0.8W/Kg$, testing for other channels are optional.
2. When SAR or MPE is not measured at the maximum power level allowed for production to the individual channels tested to determine compliance.

SAR Measurement Variability

In accordance with published RF Exposure KDB procedure 865664 D01 SAR measurement 100 MHz to 6 GHz v01. These additional measurements are repeated after the completion of all measurements requiring the same head or body tissue-equivalent medium in a frequency band. The test device should be returned to ambient conditions (normal room temperature) with the battery fully charged before it is re-mounted on the device holder for the repeated measurement(s) to minimize any unexpected variations in the repeated results:

- 1) Repeated measurement is not required when the original highest measured SAR is < 0.80 W/kg; steps 2) through 4) do not apply.
- 2) When the original highest measured SAR is ≥ 0.80 W/kg, repeat that measurement once.
- 3) Perform a second repeated measurement only if the ratio of largest to smallest SAR for the original and first repeated measurements is > 1.20 or when the original or repeated measurement is ≥ 1.45 W/kg (~ 10% from the 1-g SAR limit).
- 4) Perform a third repeated measurement only if the original, first or second repeated measurement is ≥ 1.5 W/kg and the ratio of largest to smallest SAR for the original, first and second repeated measurements is > 1.20.

The Highest Measured SAR Configuration in Each Frequency Band

Head

SAR probe calibration point	Frequency Band	Freq.(MHz)	EUT Position	Meas. SAR (W/kg)		Largest to Smallest SAR Ratio
				Original	Repeated	
/	/	/	/	/	/	/

Body

SAR probe calibration point	Frequency Band	Freq.(MHz)	EUT Position	Meas. SAR (W/kg)		Largest to Smallest SAR Ratio
				Original	Repeated	
/	/	/	/	/	/	/

Note:

1. Second Repeated Measurement is not required since the ratio of the largest to smallest SAR for the original and first repeated measurement is not > 1.20.
2. The measured SAR results **do not** have to be scaled to the maximum tune-up tolerance to determine if repeated measurements are required.
3. SAR measurement variability must be assessed for each frequency band, which is determined by the **SAR probe calibration point and tissue-equivalent medium** used for the device measurements.

SAR DUT HOLDER PERTURBATIONS

In accordance with TCB workshop October 2016:

1) SAR perturbation due to test device holders, depending on antenna locations, buttons locations on phones or device, form factor (e.g. dongles etc.), the measured SAR could be influenced by the relative positions of the test device and its holder

2) SAR measurement standards have included protocols to evaluate this with a flat phantom, with and without the device holder

3) When the highest reported SAR of an antenna is > 1.2 W/kg, holder perturbation verification is required for each antenna, using the highest SAR configuration among all applicable frequency bands in the same exact device and holder positions used for head and body SAR measurements; i.e. same device/button locations in the holder

Per IEEE 1528: 2013/Annex E/E.4.1.1: Device holder perturbation tolerance for a specific test device: Type B
 When it is unknown if a device holder perturbs the fields of a test device, the SAR uncertainty shall be assessed with a flat phantom (see Clause 5) by comparing the SAR with and without the device holder according to the following tests:

The SAR tolerance for device holder disturbance is computed using Equation (E.21) and entered in the corresponding row of the appropriate uncertainty table with an assumed rectangular probability distribution and $\nu_i = \infty$ degrees of freedom:

$$SAR_{tolerance} [\%] = 100 \times \left(\frac{SAR_{w/holder} - SAR_{w/o holder}}{SAR_{w/o holder}} \right) \tag{E.21}$$

The Highest Measured SAR Configuration among all applicable Frequency Band

Frequency Band	Freq.(MHz)	EUT Position	Meas. SAR (W/kg)		The Device holder perturbation uncertainty
			With holder	Without holder	
/	/	/	/	/	/

SAR SIMULTANEOUS TRANSMISSION DESCRIPTION

The device does not have simultaneous transmission capability.

SAR Plots

Plot: 1#

DUT: DECT 6.0 cordless telephone; Type: BL108-2; Serial: 2VX9-2

Communication System: UID 0, DECT (0); Frequency: 1924.99 MHz; Duty Cycle: 1:25.97

Medium parameters used: $f = 1924.99$ MHz; $\sigma = 1.407$ S/m; $\epsilon_r = 40.269$; $\rho = 1000$ kg/m³

Phantom section: Left Section

DASY5 Configuration:

- Probe: EX3DV4 - SN7896; ConvF(6.96, 7.29, 7.3) @ 1924.99 MHz; Calibrated: 11/7/2024
- Sensor-Surface: 1.4mm (Mechanical Surface Detection)
- Electronics: DAE4 Sn1325; Calibrated: 10/8/2024
- Phantom: SAM-Twin V8.0 P1aP2a; Type: QD 000 P41 AA ;
- Measurement SW: DASY52, Version 52.10 (4); SEMCAD X Version 14.6.14 (7501)

Head Left Cheek/DECT Mid/Area Scan (8x9x1): Measurement grid: dx=15mm, dy=15mm

Maximum value of SAR (measured) = 0.0252 W/kg

Head Left Cheek/DECT Mid/Zoom Scan (5x5x7)/Cube 0: Measurement grid: dx=8mm, dy=8mm, dz=5mm

Reference Value = 3.015 V/m; Power Drift = -0.16 dB

Peak SAR (extrapolated) = 0.0570 W/kg

SAR(1 g) = 0.020 W/kg; SAR(10 g) = 0.012 W/kg

Smallest distance from peaks to all points 3 dB below: Larger than measurement grid (> 16 mm)

Ratio of SAR at M2 to SAR at M1 = 67.4%

Maximum value of SAR (measured) = 0.0269 W/kg

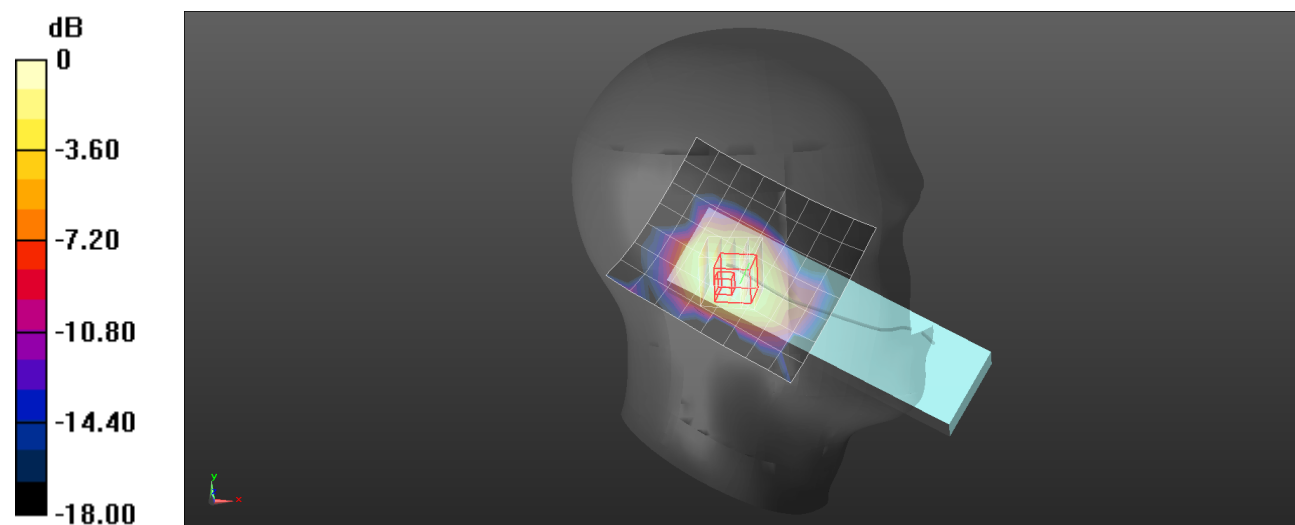

0 dB = 0.0269 W/kg = -15.70 dBW/kg

Plot: 2#

DUT: DECT 6.0 cordless telephone; Type: BL108-2; Serial: 2VX9-2

Communication System: UID 0, DECT (0); Frequency: 1924.99 MHz;Duty Cycle: 1:25.97

Medium parameters used: f = 1924.99 MHz; $\sigma = 1.407$ S/m; $\epsilon_r = 40.269$; $\rho = 1000$ kg/m³

Phantom section: Left Section

DASY5 Configuration:

- Probe: EX3DV4 - SN7896; ConvF(6.96, 7.29, 7.3) @ 1924.99 MHz; Calibrated: 11/7/2024
- Sensor-Surface: 1.4mm (Mechanical Surface Detection)
- Electronics: DAE4 Sn1325; Calibrated: 10/8/2024
- Phantom: SAM-Twin V8.0 P1aP2a; Type: QD 000 P41 AA ;
- Measurement SW: DASY52, Version 52.10 (4); SEMCAD X Version 14.6.14 (7501)

Head Left Tilt/DECT Mid/Area Scan (8x9x1): Measurement grid: dx=15mm, dy=15mm

Maximum value of SAR (measured) = 0.0157 W/kg

Head Left Tilt/DECT Mid/Zoom Scan (5x5x7)/Cube 0: Measurement grid: dx=8mm, dy=8mm, dz=5mm

Reference Value = 2.251 V/m; Power Drift = -0.12 dB

Peak SAR (extrapolated) = 0.0170 W/kg

SAR(1 g) = 0.012 W/kg; SAR(10 g) = 0.0069 W/kg

Smallest distance from peaks to all points 3 dB below: Larger than measurement grid (> 16 mm)

Ratio of SAR at M2 to SAR at M1 = 64.5%

Maximum value of SAR (measured) = 0.0150 W/kg

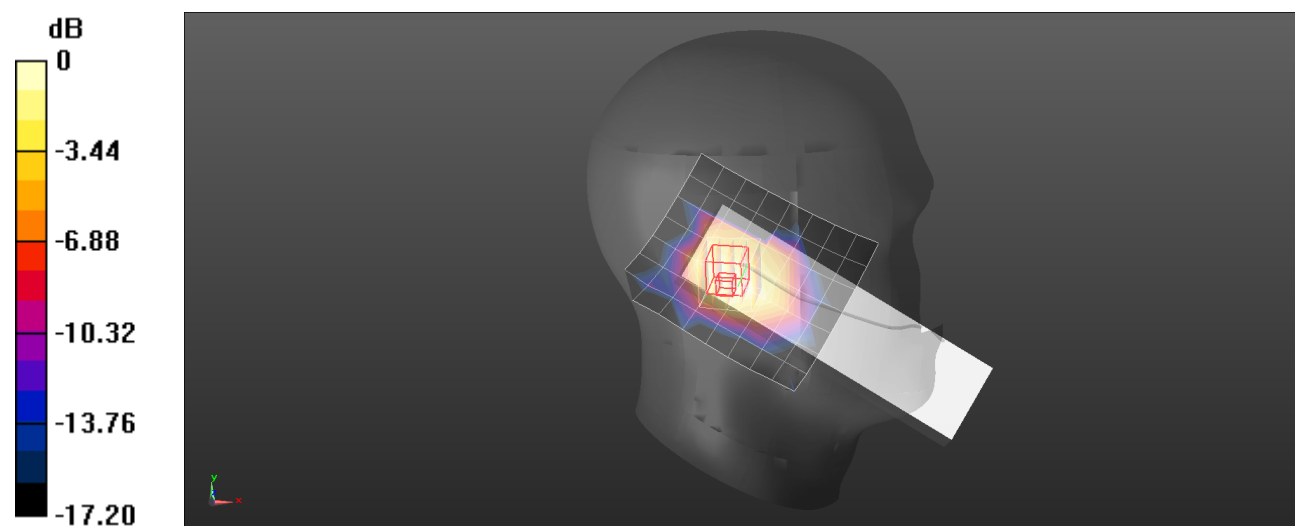

0 dB = 0.0150 W/kg = -18.24 dBW/kg

Plot: 3#

DUT: DECT 6.0 cordless telephone; Type: BL108-2; Serial: 2VX9-2

Communication System: UID 0, DECT (0); Frequency: 1921.54 MHz;Duty Cycle: 1:25.97

Medium parameters used: f = 1921.54 MHz; $\sigma = 1.407$ S/m; $\epsilon_r = 40.273$; $\rho = 1000$ kg/m³

Phantom section: Right Section

DASY5 Configuration:

- Probe: EX3DV4 - SN7896; ConvF(6.96, 7.29, 7.3) @ 1921.54 MHz; Calibrated: 11/7/2024
- Sensor-Surface: 1.4mm (Mechanical Surface Detection)
- Electronics: DAE4 Sn1325; Calibrated: 10/8/2024
- Phantom: SAM-Twin V8.0 P1aP2a; Type: QD 000 P41 AA ;
- Measurement SW: DASY52, Version 52.10 (4); SEMCAD X Version 14.6.14 (7501)

Head Right Cheek/DECT Low/Area Scan (8x9x1): Measurement grid: dx=15mm, dy=15mm

Maximum value of SAR (measured) = 0.0391 W/kg

Head Right Cheek/DECT Low/Zoom Scan (5x5x7)/Cube 0: Measurement grid: dx=8mm, dy=8mm, dz=5mm

Reference Value = 3.026 V/m; Power Drift = -0.20 dB

Peak SAR (extrapolated) = 0.0460 W/kg

SAR(1 g) = 0.027 W/kg; SAR(10 g) = 0.015 W/kg

Smallest distance from peaks to all points 3 dB below: Larger than measurement grid (> 16 mm)

Ratio of SAR at M2 to SAR at M1 = 60.5%

Maximum value of SAR (measured) = 0.0360 W/kg

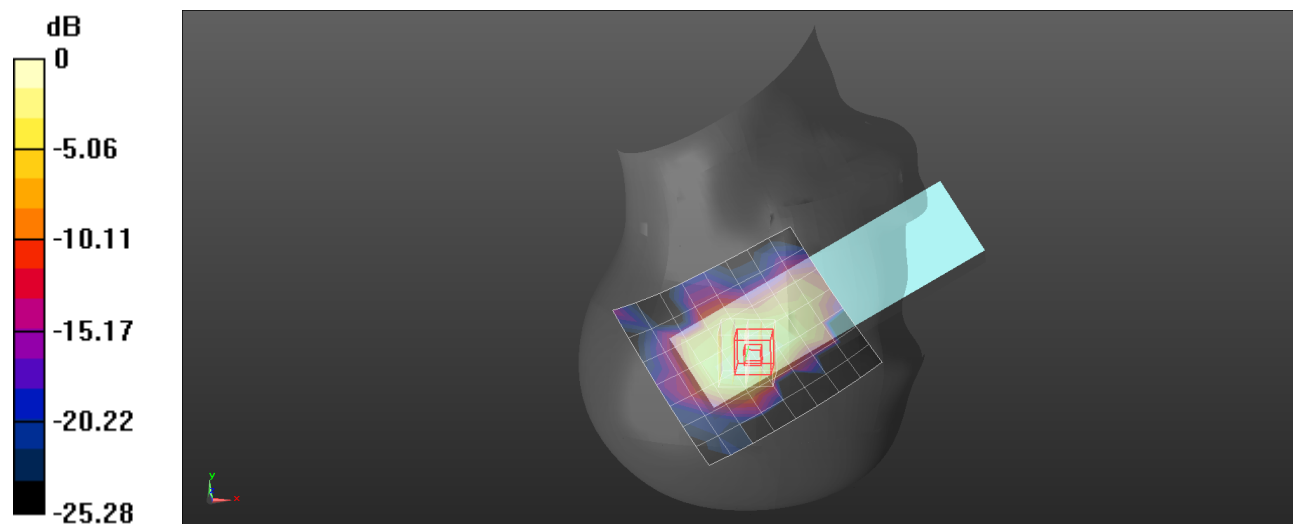

0 dB = 0.0360 W/kg = -14.44 dBW/kg

Plot: 4#**DUT: DECT 6.0 cordless telephone; Type: BL108-2; Serial: 2VX9-2**

Communication System: UID 0, DECT (0); Frequency: 1924.99 MHz;Duty Cycle: 1:25.97

Medium parameters used: $f = 1924.99$ MHz; $\sigma = 1.407$ S/m; $\epsilon_r = 40.269$; $\rho = 1000$ kg/m³

Phantom section: Right Section

DASY5 Configuration:

- Probe: EX3DV4 - SN7896; ConvF(6.96, 7.29, 7.3) @ 1924.99 MHz; Calibrated: 11/7/2024
- Sensor-Surface: 1.4mm (Mechanical Surface Detection)
- Electronics: DAE4 Sn1325; Calibrated: 10/8/2024
- Phantom: SAM-Twin V8.0 P1aP2a; Type: QD 000 P41 AA ;
- Measurement SW: DASY52, Version 52.10 (4); SEMCAD X Version 14.6.14 (7501)

Head Right Cheek/DECT Mid/Area Scan (8x9x1): Measurement grid: dx=15mm, dy=15mm

Maximum value of SAR (measured) = 0.0400 W/kg

Head Right Cheek/DECT Mid/Zoom Scan (5x5x7)/Cube 0: Measurement grid: dx=8mm, dy=8mm, dz=5mm

Reference Value = 3.276 V/m; Power Drift = -0.03 dB

Peak SAR (extrapolated) = 0.0460 W/kg

SAR(1 g) = 0.028 W/kg; SAR(10 g) = 0.015 W/kg

Smallest distance from peaks to all points 3 dB below: Larger than measurement grid (> 16 mm)

Ratio of SAR at M2 to SAR at M1 = 61.4%

Maximum value of SAR (measured) = 0.0390 W/kg

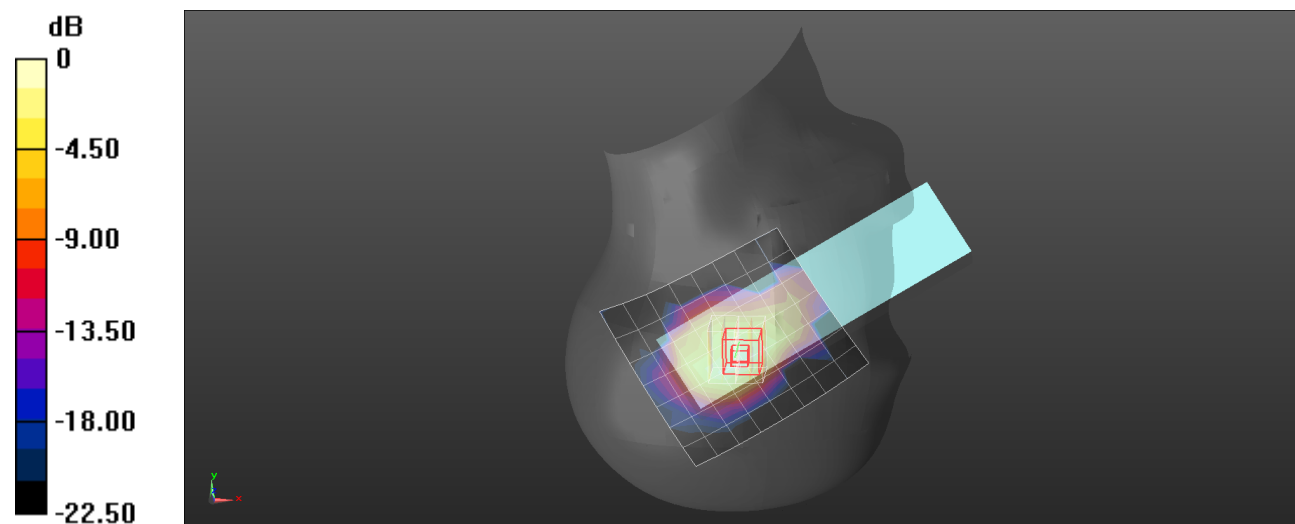

0 dB = 0.0390 W/kg = -14.09 dBW/kg

Plot: 5#

DUT: DECT 6.0 cordless telephone; Type: BL108-2; Serial: 2VX9-2

Communication System: UID 0, DECT (0); Frequency: 1928.45 MHz;Duty Cycle: 1:25.97

Medium parameters used: f = 1928.45 MHz; $\sigma = 1.407$ S/m; $\epsilon_r = 40.266$; $\rho = 1000$ kg/m³

Phantom section: Right Section

DASY5 Configuration:

- Probe: EX3DV4 - SN7896; ConvF(6.96, 7.29, 7.3) @ 1928.45 MHz; Calibrated: 11/7/2024
- Sensor-Surface: 1.4mm (Mechanical Surface Detection)
- Electronics: DAE4 Sn1325; Calibrated: 10/8/2024
- Phantom: SAM-Twin V8.0 P1aP2a; Type: QD 000 P41 AA ;
- Measurement SW: DASY52, Version 52.10 (4); SEMCAD X Version 14.6.14 (7501)

Head Right Cheek/DECT High/Area Scan (8x9x1): Measurement grid: dx=15mm, dy=15mm

Maximum value of SAR (measured) = 0.0388 W/kg

Head Right Cheek/DECT High/Zoom Scan (5x5x7)/Cube 0: Measurement grid: dx=8mm, dy=8mm, dz=5mm

Reference Value = 0.8150 V/m; Power Drift = 0.01 dB

Peak SAR (extrapolated) = 0.0430 W/kg

SAR(1 g) = 0.026 W/kg; SAR(10 g) = 0.014 W/kg

Smallest distance from peaks to all points 3 dB below: Larger than measurement grid (> 16 mm)

Ratio of SAR at M2 to SAR at M1 = 69.8%

Maximum value of SAR (measured) = 0.0352 W/kg

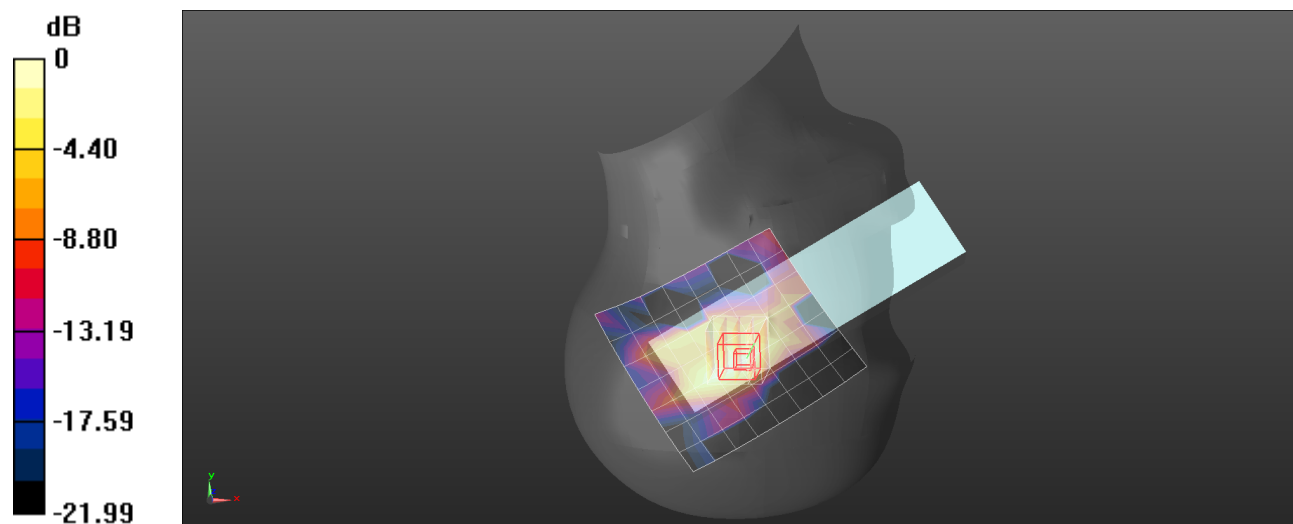

0 dB = 0.0352 W/kg = -14.53 dBW/kg

Plot: 6#**DUT: DECT 6.0 cordless telephone; Type: BL108-2; Serial: 2VX9-2**

Communication System: UID 0, DECT (0); Frequency: 1924.99 MHz; Duty Cycle: 1:25.97

Medium parameters used: $f = 1924.99$ MHz; $\sigma = 1.407$ S/m; $\epsilon_r = 40.269$; $\rho = 1000$ kg/m³

Phantom section: Right Section

DASY5 Configuration:

- Probe: EX3DV4 - SN7896; ConvF(6.96, 7.29, 7.3) @ 1924.99 MHz; Calibrated: 11/7/2024
- Sensor-Surface: 1.4mm (Mechanical Surface Detection)
- Electronics: DAE4 Sn1325; Calibrated: 10/8/2024
- Phantom: SAM-Twin V8.0 P1aP2a; Type: QD 000 P41 AA ;
- Measurement SW: DASY52, Version 52.10 (4); SEMCAD X Version 14.6.14 (7501)

Head Right Tilt/DECT Mid/Area Scan (8x9x1): Measurement grid: dx=15mm, dy=15mm

Maximum value of SAR (measured) = 0.0194 W/kg

Head Right Tilt/DECT Mid/Zoom Scan (5x5x7)/Cube 0: Measurement grid: dx=8mm, dy=8mm, dz=5mm

Reference Value = 2.016 V/m; Power Drift = 0.06 dB

Peak SAR (extrapolated) = 0.0190 W/kg

SAR(1 g) = 0.013 W/kg; SAR(10 g) = 0.00649 W/kg

Smallest distance from peaks to all points 3 dB below: Larger than measurement grid (> 16 mm)

Ratio of SAR at M2 to SAR at M1 = 63.6%

Maximum value of SAR (measured) = 0.0173 W/kg

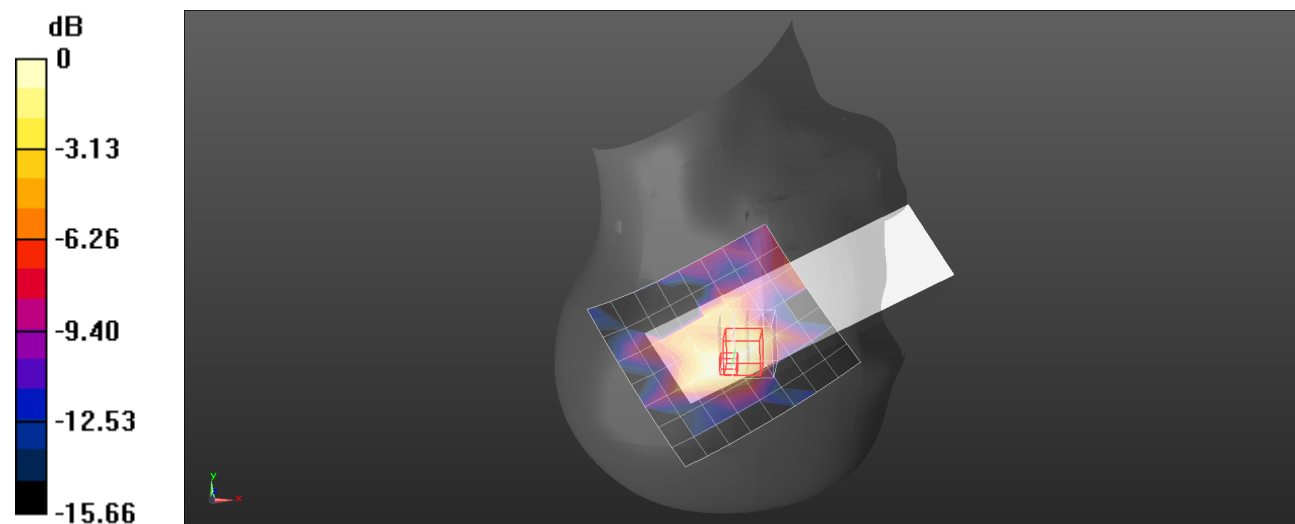

0 dB = 0.0173 W/kg = -17.62 dBW/kg

Plot: 7#

DUT: DECT 6.0 cordless telephone; Type: BL108-2; Serial: 2VX9-2

Communication System: UID 0, DECT (0); Frequency: 1921.54 MHz;Duty Cycle: 1:25.97

Medium parameters used: f = 1921.54 MHz; $\sigma = 1.407$ S/m; $\epsilon_r = 40.273$; $\rho = 1000$ kg/m³

Phantom section: Flat Section

DASY5 Configuration:

- Probe: EX3DV4 - SN7896; ConvF(6.96, 7.29, 7.3) @ 1921.54 MHz; Calibrated: 11/7/2024
- Sensor-Surface: 1.4mm (Mechanical Surface Detection)
- Electronics: DAE4 Sn1325; Calibrated: 10/8/2024
- Phantom: SAM-Twin V8.0 P1aP2a; Type: QD 000 P41 AA ;
- Measurement SW: DASY52, Version 52.10 (4); SEMCAD X Version 14.6.14 (7501)

Body Front/DECT Low/Area Scan (8x13x1): Measurement grid: dx=15mm, dy=15mm

Maximum value of SAR (measured) = 0.0353 W/kg

Body Front/DECT Low/Zoom Scan (5x5x7)/Cube 0: Measurement grid: dx=8mm, dy=8mm, dz=5mm

Reference Value = 3.292 V/m; Power Drift = -0.02 dB

Peak SAR (extrapolated) = 0.0480 W/kg

SAR(1 g) = 0.028 W/kg; SAR(10 g) = 0.014 W/kg

Smallest distance from peaks to all points 3 dB below: Larger than measurement grid (> 16 mm)

Ratio of SAR at M2 to SAR at M1 = 59%

Maximum value of SAR (measured) = 0.0408 W/kg

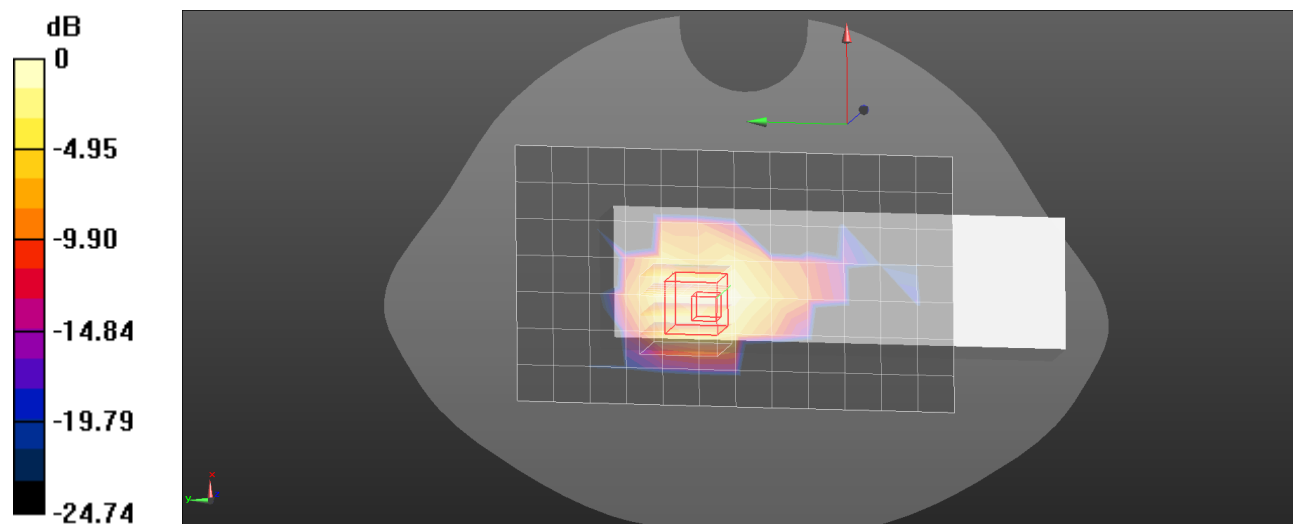

0 dB = 0.0408 W/kg = -13.89 dBW/kg

Plot: 8#

DUT: DECT 6.0 cordless telephone; Type: BL108-2; Serial: 2VX9-2

Communication System: UID 0, DECT (0); Frequency: 1924.99 MHz;Duty Cycle: 1:25.97

Medium parameters used: f = 1924.99 MHz; $\sigma = 1.407$ S/m; $\epsilon_r = 40.269$; $\rho = 1000$ kg/m³

Phantom section: Flat Section

DASY5 Configuration:

- Probe: EX3DV4 - SN7896; ConvF(6.96, 7.29, 7.3) @ 1924.99 MHz; Calibrated: 11/7/2024
- Sensor-Surface: 1.4mm (Mechanical Surface Detection)
- Electronics: DAE4 Sn1325; Calibrated: 10/8/2024
- Phantom: SAM-Twin V8.0 P1aP2a; Type: QD 000 P41 AA ;
- Measurement SW: DASY52, Version 52.10 (4); SEMCAD X Version 14.6.14 (7501)

Body Front/DECT Mid/Area Scan (8x13x1): Measurement grid: dx=15mm, dy=15mm

Maximum value of SAR (measured) = 0.0470 W/kg

Body Front/DECT Mid/Zoom Scan (5x5x7)/Cube 0: Measurement grid: dx=8mm, dy=8mm, dz=5mm

Reference Value = 3.460 V/m; Power Drift = -0.04 dB

Peak SAR (extrapolated) = 0.0530 W/kg

SAR(1 g) = 0.032 W/kg; SAR(10 g) = 0.018 W/kg

Smallest distance from peaks to all points 3 dB below: Larger than measurement grid (> 16 mm)

Ratio of SAR at M2 to SAR at M1 = 56.8%

Maximum value of SAR (measured) = 0.0446 W/kg

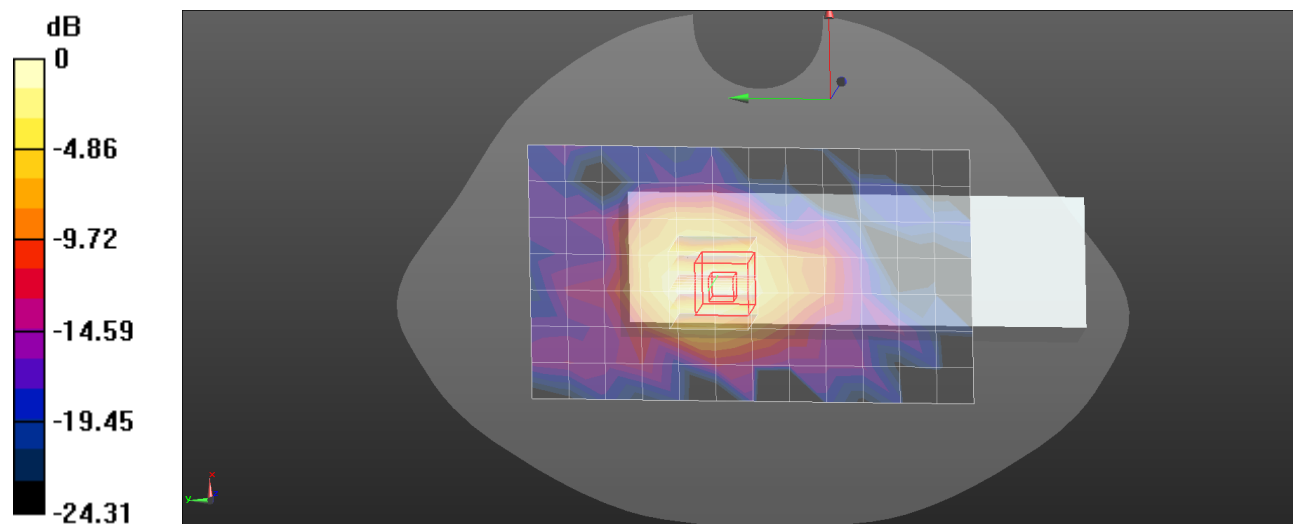

0 dB = 0.0446 W/kg = -13.51 dBW/kg

Plot: 9#

DUT: DECT 6.0 cordless telephone; Type: BL108-2; Serial: 2VX9-2

Communication System: UID 0, DECT (0); Frequency: 1928.45 MHz;Duty Cycle: 1:25.97

Medium parameters used: f = 1928.45 MHz; $\sigma = 1.407$ S/m; $\epsilon_r = 40.266$; $\rho = 1000$ kg/m³

Phantom section: Flat Section

DASY5 Configuration:

- Probe: EX3DV4 - SN7896; ConvF(6.96, 7.29, 7.3) @ 1928.45 MHz; Calibrated: 11/7/2024
- Sensor-Surface: 1.4mm (Mechanical Surface Detection)
- Electronics: DAE4 Sn1325; Calibrated: 10/8/2024
- Phantom: SAM-Twin V8.0 P1aP2a; Type: QD 000 P41 AA ;
- Measurement SW: DASY52, Version 52.10 (4); SEMCAD X Version 14.6.14 (7501)

Body Front/DECT High/Area Scan (8x13x1): Measurement grid: dx=15mm, dy=15mm

Maximum value of SAR (measured) = 0.0360 W/kg

Body Front/DECT High/Zoom Scan (5x5x7)/Cube 0: Measurement grid: dx=8mm, dy=8mm, dz=5mm

Reference Value = 3.357 V/m; Power Drift = -0.07 dB

Peak SAR (extrapolated) = 0.0500 W/kg

SAR(1 g) = 0.027 W/kg; SAR(10 g) = 0.014 W/kg

Smallest distance from peaks to all points 3 dB below: Larger than measurement grid (> 16 mm)

Ratio of SAR at M2 to SAR at M1 = 58.7%

Maximum value of SAR (measured) = 0.0411 W/kg

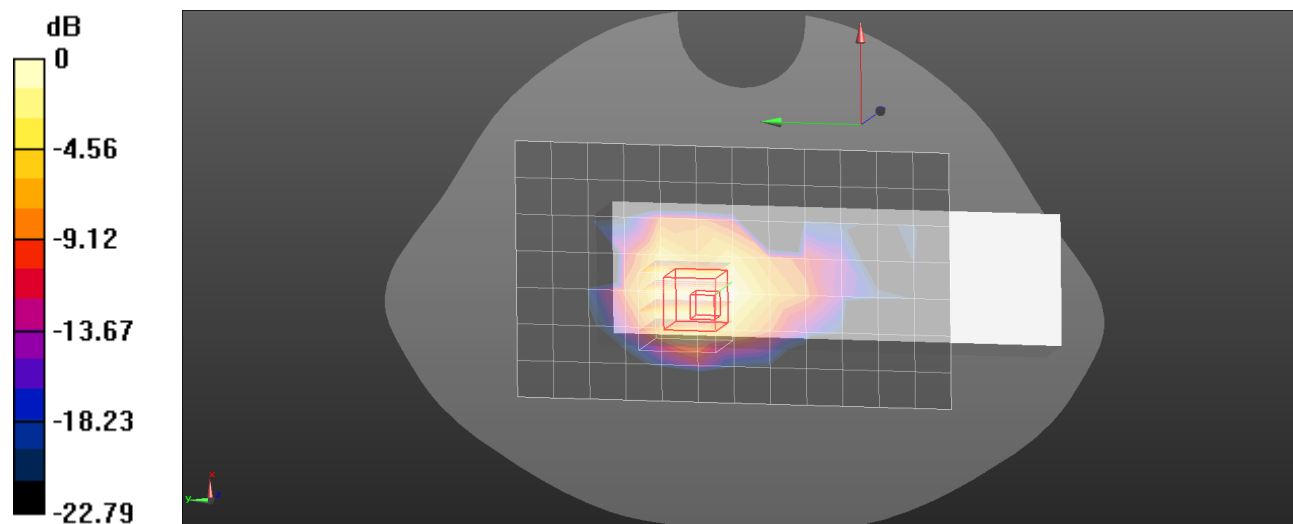

0 dB = 0.0411 W/kg = -13.86 dBW/kg

Plot: 10#

DUT: DECT 6.0 cordless telephone; Type: BL108-2; Serial: 2VX9-2

Communication System: UID 0, DECT (0); Frequency: 1924.99 MHz;Duty Cycle: 1:25.97

Medium parameters used: f = 1924.99 MHz; $\sigma = 1.407$ S/m; $\epsilon_r = 40.269$; $\rho = 1000$ kg/m³

Phantom section: Flat Section

DASY5 Configuration:

- Probe: EX3DV4 - SN7896; ConvF(6.96, 7.29, 7.3) @ 1924.99 MHz; Calibrated: 11/7/2024
- Sensor-Surface: 1.4mm (Mechanical Surface Detection)
- Electronics: DAE4 Sn1325; Calibrated: 10/8/2024
- Phantom: SAM-Twin V8.0 P1aP2a; Type: QD 000 P41 AA ;
- Measurement SW: DASY52, Version 52.10 (4); SEMCAD X Version 14.6.14 (7501)

Body Back/DECT Mid/Area Scan (8x11x1): Measurement grid: dx=15mm, dy=15mm

Maximum value of SAR (measured) = 0.0242 W/kg

Body Back/DECT Mid/Zoom Scan (5x5x7)/Cube 0: Measurement grid: dx=8mm, dy=8mm, dz=5mm

Reference Value = 3.418 V/m; Power Drift = -0.06 dB

Peak SAR (extrapolated) = 0.0290 W/kg

SAR(1 g) = 0.017 W/kg; SAR(10 g) = 0.00802 W/kg

Smallest distance from peaks to all points 3 dB below: Larger than measurement grid (> 16 mm)

Ratio of SAR at M2 to SAR at M1 = 60.2%

Maximum value of SAR (measured) = 0.0262 W/kg

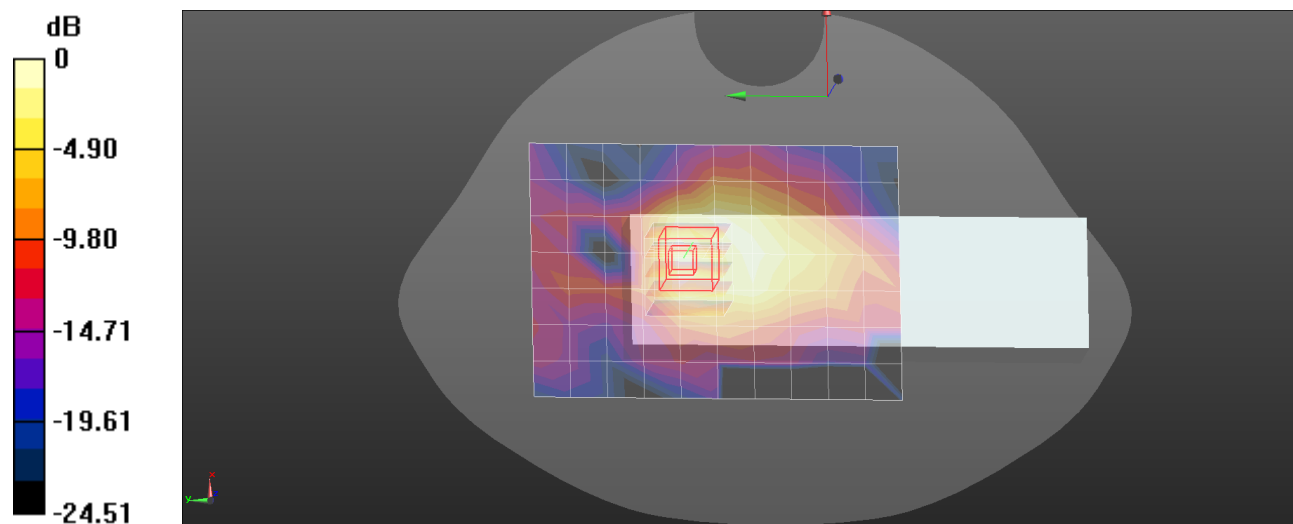

0 dB = 0.0262 W/kg = -15.82 dBW/kg

APPENDIX A MEASUREMENT UNCERTAINTY

The uncertainty budget has been determined for the measurement system and is given in the following Table.

Measurement uncertainty evaluation for IEEE1528-2013 SAR test

Source of uncertainty	Tolerance/uncertainty ± %	Probability distribution	Divisor	ci (1 g)	ci (10 g)	Standard uncertainty ± %, (1 g)	Standard uncertainty ± %, (10 g)
Measurement system							
Probe calibration	13.9	N	1	1	1	13.9	13.9
Axial Isotropy	4.7	R	√3	1	1	2.7	2.7
Hemispherical Isotropy	9.6	R	√3	0	0	0.0	0.0
Boundary effect	1.0	R	√3	1	1	0.6	0.6
Linearity	4.7	R	√3	1	1	2.7	2.7
Detection limits	1.0	R	√3	1	1	0.6	0.6
Modulation response	4.0	R	√3	1	1	2.3	2.3
Readout electronics	0.3	N	1	1	1	0.3	0.3
Response time	0.0	R	√3	1	1	0.0	0.0
Integration time	0.0	R	√3	1	1	0.0	0.0
RF ambient conditions – noise	1.0	R	√3	1	1	0.6	0.6
RF ambient conditions–reflections	1.0	R	√3	1	1	0.6	0.6
Probe positioner mech. Restrictions	0.8	R	√3	1	1	0.5	0.5
Probe positioning with respect to phantom shell	6.7	R	√3	1	1	3.9	3.9
Extrapolation, interpolation, and integrations algorithms for max. SAR evaluation	3.9	R	√3	1	1	2.3	2.3
Test sample related							
Test sample positioning	2.8	N	1	1	1	2.8	2.8
Device holder uncertainty	6.3	N	1	1	1	6.3	6.3
Drift of output power	5.0	R	√3	1	1	2.9	2.9
SAR scaling	2.0	R	√3	1	1	1.2	1.2
Phantom and tissue parameters							
Phantom uncertainty (shape and thickness tolerances)	4.0	R	√3	1	1	2.3	2.3
Uncertainty in SAR correction for deviations in permittivity and conductivity	1.9	N	1	1	0.84	1.9	1.6
Liquid conductivity measurement	5.5	N	1	0.78	0.71	4.3	3.9
Liquid permittivity measurement	2.9	N	1	0.23	0.26	0.7	0.8
Liquid conductivity—temperature uncertainty	1.7	R	√3	0.78	0.71	0.8	0.7
Liquid permittivity—temperature uncertainty	2.7	R	√3	0.23	0.26	0.4	0.4
Combined standard uncertainty		RSS				12.2	12.0
Expanded uncertainty 95 % confidence interval)						24.3	23.9

APPENDIX B EUT TEST POSITION PHOTOS

Liquid depth $\geq 15\text{cm}$

Phantom: SAM-Twin V8.0 P1aP2a; Type: QD 000 P41 AA ; Serial: 1962

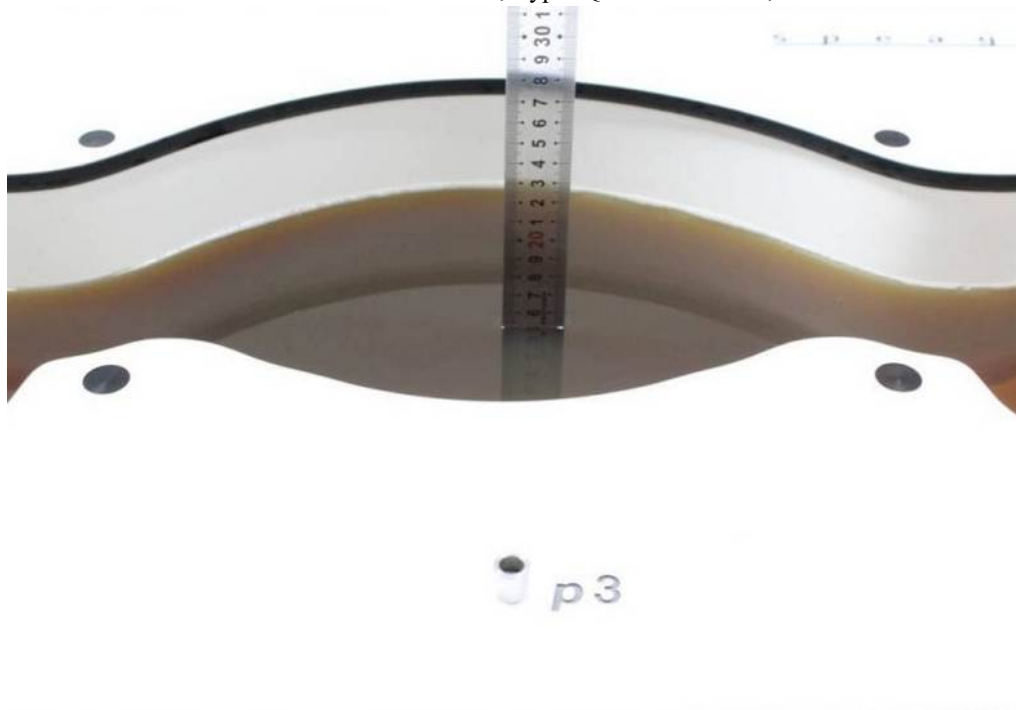

Head Left Cheek Setup Photo (0 mm)



Head Left Tilt Setup Photo (0 mm)



Head Right Cheek Setup Photo (0 mm)

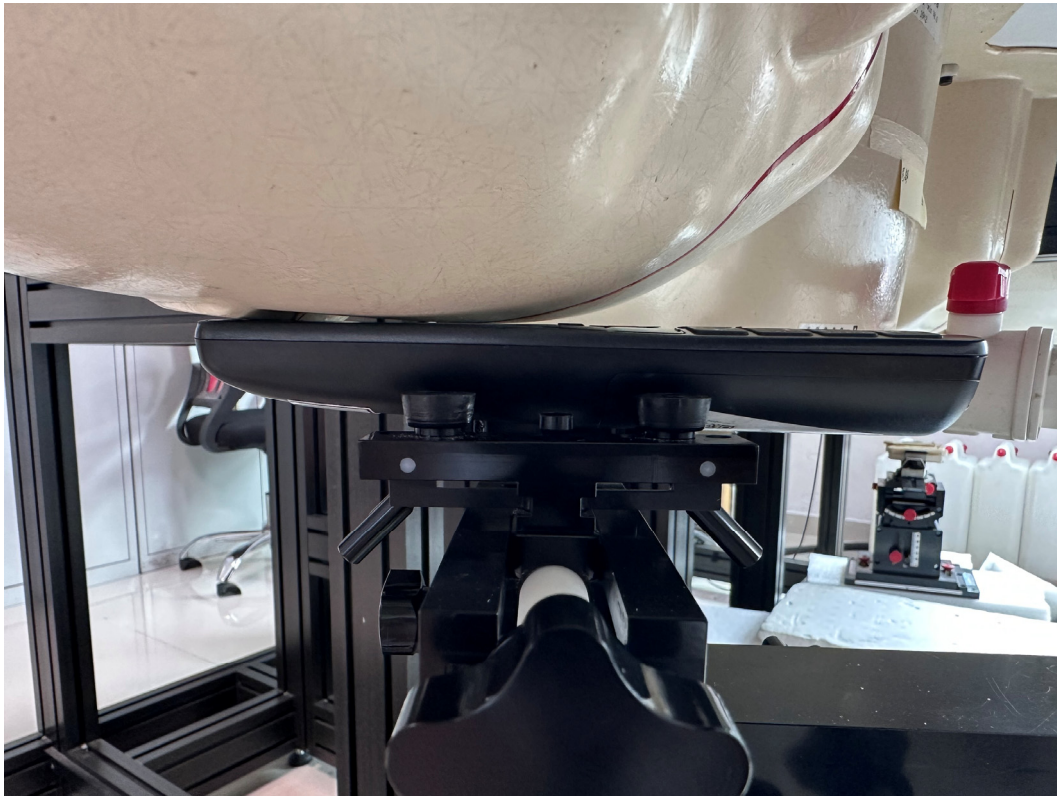

Head Right Tilt Setup Photo (0 mm)



Body Front Setup Photo (0 mm)

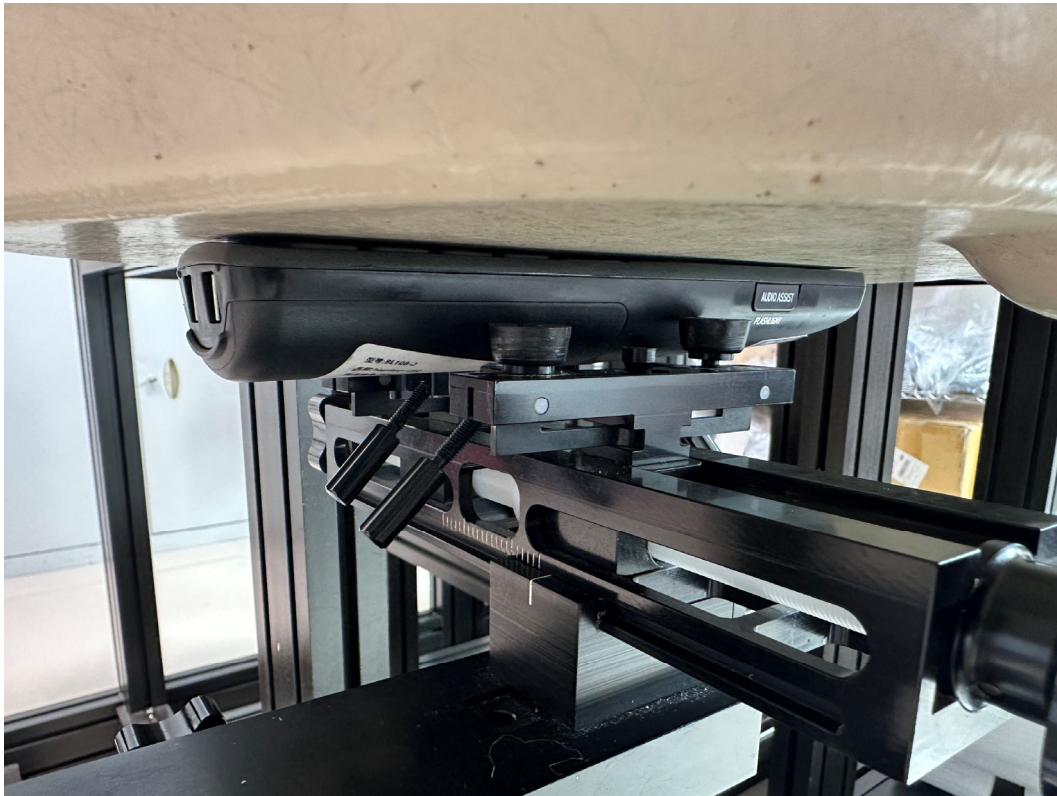

Body Back Setup Photo (0 mm)



APPENDIX C CALIBRATION CERTIFICATES

Calibration Laboratory of
 Schmid & Partner
 Engineering AG
 Zeughausstrasse 43, 8004 Zurich, Switzerland



S Schweizerischer Kalibrierdienst
 C Service suisse d'étalonnage
 S Servizio svizzero di taratura
 S Swiss Calibration Service

Accredited by the Swiss Accreditation Service (SAS)
 The Swiss Accreditation Service is one of the signatories to the EA
 Multilateral Agreement for the recognition of calibration certificates

Accreditation No.: **SCS 0108**

Client **BACL**
 Sunnysvale, USA

Certificate No. **EX-7896_Nov24**

CALIBRATION CERTIFICATE

Object **EX3DV4 - SN:7896**

Calibration procedure(s) **QA CAL-01.v10, QA CAL-12.v10, QA CAL-14.v7, QA CAL-23.v6, QA CAL-25.v8**
 Calibration procedure for dosimetric E-field probes

Calibration date **November 07, 2024**

This calibration certificate documents the traceability to national standards, which realize the physical units of measurements (SI). The measurements and the uncertainties with confidence probability are given on the following pages and are part of the certificate.

All calibrations have been conducted in the closed laboratory facility: environment temperature (22 ± 3) °C and humidity < 70%.

Calibration Equipment used (M&TE critical for calibration)

Primary Standards	ID	Cal Date (Certificate No.)	Scheduled Calibration
Power meter NRP2	SN: 104778	26-Mar-24 (No. 217-04036/04037)	Mar-25
Power sensor NRP-Z91	SN: 103244	26-Mar-24 (No. 217-04036)	Mar-25
OCP DAK-3.5 (weighted)	SN: 1249	23-Sep-24 (OCP-DAK3.5-1249_Sep24)	Sep-25
OCP DAK-12	SN: 1016	24-Sep-24 (OCP-DAK12-1016_Sep24)	Sep-25
Reference 20 dB Attenuator	SN: CC2552 (20x)	26-Mar-24 (No. 217-04046)	Mar-25
DAE4	SN: 660	23-Feb-24 (No. DAE4-660_Feb24)	Feb-25
Reference Probe EX3DV4	SN: 7349	03-Jun-24 (No. EX3-7349_Jun24)	Jun-25

Secondary Standards	ID	Check Date (in house)	Scheduled Check
Power meter E4419B	SN: GB41293874	06-Apr-16 (in house check Jun-24)	In house check: Jun-26
Power sensor E4412A	SN: MY41498087	06-Apr-16 (in house check Jun-24)	In house check: Jun-26
Power sensor E4412A	SN: 000110210	06-Apr-16 (in house check Jun-24)	In house check: Jun-26
RF generator HP 8648C	SN: US3642U01700	04-Aug-99 (in house check Jun-24)	In house check: Jun-26
Network Analyzer E8358A	SN: US41080477	31-Mar-14 (in house check Sep-24)	In house check: Sep-26

	Name	Function	Signature
Calibrated by	Joanna Lleshaj	Laboratory Technician	
Approved by	Sven Kühn	Technical Manager	

Issued: November 08, 2024

This calibration certificate shall not be reproduced except in full without written approval of the laboratory.

Calibration Laboratory ofSchmid & Partner
Engineering AG

Zeughausstrasse 43, 8004 Zurich, Switzerland



S Schweizerischer Kalibrierdienst
C Service suisse d'étalonnage
S Servizio svizzero di taratura
S Swiss Calibration Service

Accredited by the Swiss Accreditation Service (SAS)
The Swiss Accreditation Service is one of the signatories to the EA
Multilateral Agreement for the recognition of calibration certificates

Accreditation No.: SCS 0108

Glossary

TSL	tissue simulating liquid
NORM _{x,y,z}	sensitivity in free space
ConvF	sensitivity in TSL / NORM _{x,y,z}
DCP	diode compression point
CF	crest factor (1/duty_cycle) of the RF signal
A, B, C, D	modulation dependent linearization parameters
Polarization φ	φ rotation around probe axis
Polarization θ	θ rotation around an axis that is in the plane normal to probe axis (at measurement center), i.e., $\theta = 0$ is normal to probe axis
Connector Angle	information used in DASY system to align probe sensor X to the robot coordinate system

Calibration is Performed According to the Following Standards:

- IEC/IEEE 62209-1528, "Measurement Procedure For The Assessment Of Specific Absorption Rate Of Human Exposure To Radio Frequency Fields From Hand-Held And Body-Worn Wireless Communication Devices – Part 1528: Human Models, Instrumentation And Procedures (Frequency Range of 4 MHz to 10 GHz)", October 2020.
- KDB 865664, "SAR Measurement Requirements for 100 MHz to 6 GHz"

Methods Applied and Interpretation of Parameters:

- NORM_{x,y,z}**: Assessed for E-field polarization $\theta = 0$ ($f \leq 900$ MHz in TEM-cell; $f > 1800$ MHz: R22 waveguide). NORM_{x,y,z} are only intermediate values, i.e., the uncertainties of NORM_{x,y,z} does not affect the E²-field uncertainty inside TSL (see below ConvF).
- NORM(f)_{x,y,z} = NORM_{x,y,z} * frequency_response** (see Frequency Response Chart). This linearization is implemented in DASY4 software versions later than 4.2. The uncertainty of the frequency response is included in the stated uncertainty of ConvF.
- DCP_{x,y,z}**: DCP are numerical linearization parameters assessed based on the data of power sweep with CW signal. DCP does not depend on frequency nor media.
- PAR**: PAR is the Peak to Average Ratio that is not calibrated but determined based on the signal characteristics
- A_{x,y,z}; B_{x,y,z}; C_{x,y,z}; D_{x,y,z}; VR_{x,y,z}**: A, B, C, D are numerical linearization parameters assessed based on the data of power sweep for specific modulation signal. The parameters do not depend on frequency nor media. VR is the maximum calibration range expressed in RMS voltage across the diode.
- ConvF and Boundary Effect Parameters**: Assessed in flat phantom using E-field (or Temperature Transfer Standard for $f \leq 800$ MHz) and inside waveguide using analytical field distributions based on power measurements for $f > 800$ MHz. The same setups are used for assessment of the parameters applied for boundary compensation (alpha, depth) of which typical uncertainty values are given. These parameters are used in DASY4 software to improve probe accuracy close to the boundary. The sensitivity in TSL corresponds to NORM_{x,y,z} * ConvF whereby the uncertainty corresponds to that given for ConvF. A frequency dependent ConvF is used in DASY version 4.4 and higher which allows extending the validity from ± 50 MHz to ± 100 MHz.
- Spherical isotropy (3D deviation from isotropy)**: in a field of low gradients realized using a flat phantom exposed by a patch antenna.
- Sensor Offset**: The sensor offset corresponds to the offset of virtual measurement center from the probe tip (on probe axis). No tolerance required.
- Connector Angle**: The angle is assessed using the information gained by determining the NORM_x (no uncertainty required).

EX3DV4 - SN:7896

November 07, 2024

Parameters of Probe: EX3DV4 - SN:7896

Basic Calibration Parameters

	Sensor X	Sensor Y	Sensor Z	Unc (k = 2)
Norm ($\mu\text{V}/(\text{V}/\text{m})^2$) ^A	0.67	0.58	0.62	±10.1%
DCP (mV) ^B	106.2	106.2	106.0	±4.7%

Calibration Results for Modulation Response

UID	Communication System Name		A dB	B dB $\sqrt{\mu\text{V}}$	C	D dB	VR mV	Max dev.	Max Unc ^E k = 2
0	CW	X	0.00	0.00	1.00	0.00	125.1	±1.5%	±4.7%
		Y	0.00	0.00	1.00		132.2		
		Z	0.00	0.00	1.00		120.5		

The reported uncertainty of measurement is stated as the standard uncertainty of measurement multiplied by the coverage factor k=2, which for a normal distribution corresponds to a coverage probability of approximately 95%.

^A The uncertainties of Norm X,Y,Z do not affect the E²-field uncertainty inside TSL (see Pages 5 and 6).
^B Linearization parameter uncertainty for maximum specified field strength.
^E Uncertainty is determined using the max. deviation from linear response applying rectangular distribution and is expressed for the square of the field value.

EX3DV4 - SN:7896

November 07, 2024

Parameters of Probe: EX3DV4 - SN:7896

Other Probe Parameters

Sensor Arrangement	Triangular
Connector Angle	28.7°
Mechanical Surface Detection Mode	enabled
Optical Surface Detection Mode	disabled
Probe Overall Length	337 mm
Probe Body Diameter	10 mm
Tip Length	9 mm
Tip Diameter	2.5 mm
Probe Tip to Sensor X Calibration Point	1 mm
Probe Tip to Sensor Y Calibration Point	1 mm
Probe Tip to Sensor Z Calibration Point	1 mm
Recommended Measurement Distance from Surface	1.4 mm

Note: Measurement distance from surface can be increased to 3–4 mm for an *Area Scan* job.

EX3DV4 - SN:7896

November 07, 2024

Parameters of Probe: EX3DV4 - SN:7896

Calibration Parameter Determined in Head Tissue Simulating Media

f (MHz) ^C	Relative Permittivity ^F	Conductivity ^F (S/m)	ConvF X	ConvF Y	ConvF Z	Alpha ^G	Depth ^G (mm)	Unc ^H (k = 2)
750	41.9	0.89	8.72	9.14	9.15	0.35	1.27	±11.0%
900	41.5	0.97	8.08	8.47	8.48	0.35	1.27	±11.0%
1750	40.1	1.37	7.20	7.55	7.56	0.35	1.27	±11.0%
1900	40.0	1.40	6.96	7.29	7.30	0.35	1.27	±11.0%
2300	39.5	1.67	6.79	7.12	7.13	0.35	1.27	±11.0%
2450	39.2	1.80	6.54	6.85	6.86	0.35	1.27	±11.0%
2600	39.0	1.96	6.60	6.92	6.93	0.35	1.27	±11.0%
3300	38.2	2.71	5.83	6.12	6.12	0.36	1.27	±13.1%
3500	37.9	2.91	5.91	6.19	6.20	0.36	1.27	±13.1%
3700	37.7	3.12	5.92	6.20	6.21	0.36	1.27	±13.1%
3900	37.5	3.32	5.79	6.07	6.07	0.36	1.27	±13.1%
5250	35.9	4.71	4.86	5.09	5.09	0.32	1.27	±13.1%
5600	35.5	5.07	4.52	4.74	4.74	0.28	1.27	±13.1%
5800	35.3	5.27	4.56	4.78	4.78	0.27	1.27	±13.1%

^C Frequency validity above 300 MHz of ±100 MHz only applies for DASY v4.4 and higher (see Page 2), else it is restricted to ±50 MHz. The uncertainty is the RSS of the ConvF uncertainty at calibration frequency and the uncertainty for the indicated frequency band. Frequency validity below 300 MHz is ±10, 25, 40, 50 and 70 MHz for ConvF assessments at 30, 64, 128, 150 and 220 MHz respectively. Validity of ConvF assessed at 6 MHz is 4–9 MHz, and ConvF assessed at 13 MHz is 9–19 MHz. Above 5 GHz frequency validity can be extended to ±110 MHz.

^F The probes are calibrated using tissue simulating liquids (TSL) that deviate for ε and σ by less than ±5% from the target values (typically better than ±3%) and are valid for TSL with deviations of up to ±10% if SAR correction is applied.

^G Alpha/Depth are determined during calibration. SPEAG warrants that the remaining deviation due to the boundary effect after compensation is always less than ±1% for frequencies below 3 GHz and below ±2% for frequencies between 3–6 GHz at any distance larger than half the probe tip diameter from the boundary.

^H The stated uncertainty is the total calibration uncertainty (k = 2) of Norm-ConvF. This is equivalent to the uncertainty component with the symbol CF in Table 9 of IEC/IEEE 62209-1528:2020.

EX3DV4 - SN:7896

November 07, 2024

Parameters of Probe: EX3DV4 - SN:7896

Calibration Parameter Determined in Head Tissue Simulating Media

f (MHz) ^C	Relative Permittivity ^F	Conductivity ^F (S/m)	ConvF X	ConvF Y	ConvF Z	Alpha ^G	Depth ^G (mm)	Unc ^H (k = 2)
6500	34.5	6.07	4.74	4.96	4.97	0.20	1.27	±18.6%

^C Frequency validity at 6.5 GHz is -600/+700 MHz, and ±700 MHz at or above 7 GHz. The uncertainty is the RSS of the ConvF uncertainty at calibration frequency and the uncertainty for the indicated frequency band.
^F The probes are calibrated using tissue simulating liquids (TSL) that deviate for ϵ and σ by less than ±10% from the target values (typically better than ±8%) and are valid for TSL with deviations of up to ±10%.
^G Alpha/Depth are determined during calibration. SPEAG warrants that the remaining deviation due to the boundary effect after compensation is always less than ±1% for frequencies below 3 GHz; below ±2% for frequencies between 3–6 GHz; and below ±4% for frequencies between 6–10 GHz at any distance larger than half the probe tip diameter from the boundary.
^H The stated uncertainty is the total calibration uncertainty (k = 2) of Norm-ConvF. This is equivalent to the uncertainty component with the symbol CF in Table 9 of IEC/IEEE 62209-1528:2020.