

TEST REPORT

Report No.: 23060382HKG-002

VTech Telecommunications Ltd.

Application For Original Grant of 47 CFR Part 15 Certification

New Family of RSS-247 Issue 3 Certification

Video Monitor - Parent unit

FCC ID: EW780-2634-01A

IC: 1135B-80263401A

Prepared and Checked by:

Approved by:

Signed on File

Leung Chun Ning, Peter

Assistant Engineer

Wong Cheuk Ho, Herbert

Assistant Supervisor

Date: September 04, 2023

Intertek's standard Terms and Conditions can be obtained at our website <http://www.intertek.com/terms/>.

The test report only allows to be revised within the retention period unless further standard or the requirement was noticed.

This report is for the exclusive use of Intertek's Client and is provided pursuant to the agreement between Intertek and its Client. Intertek's responsibility and liability are limited to the terms and conditions of the agreement. Intertek assumes no liability to any party, other than to the Client in accordance with the agreement, for any loss, expense or damage occasioned by the use of this report. Only the Client is authorized to permit copying or distribution of this report and then only in its entirety. Any use of the Intertek name or one of its marks for the sale or advertisement of the tested material, product or service must first be approved in writing by Intertek. The observations and test results in this report are relevant only to the sample tested. This report by itself does not imply that the material, product, or service is or has ever been under an Intertek certification program.

© 2017 Intertek

TEST REPORT

GENERAL INFORMATION

Grantee:	VTech Telecommunications Ltd.
Grantee Address:	23/F., Tai Ping Industrial Centre, Block 1, 57 Ting Kok Road, Tai Po, Hong Kong.
Manufacturer Name:	VTech (Dongguan) Telecommunications Limited
Manufacturer Address:	VTech Science Park, Xia Ling Bei Management Zone, Liaobu, Dongguan, Guangdong, China.
FCC Specification Standard:	FCC Part 15, October 1, 2021 Edition
FCC ID:	EW780-2634-01A
FCC Model(s):	RM5756HD PU, RM5756-2HD PU, RM5756-abHD PU, RM5856HD PU, RM5856-2HD PU
IC Specification Standard:	RSS-247 Issue 3, August 2023 RSS-Gen Issue 5 Amendment 2, February 2021
IC:	1135B-80263401A
HVIN:	35-400370PUA
PMN:	RM5756HD PU, RM5756-2HD PU, RM5856HD PU, RM5856-2HD PU
Type of EUT:	Spread Spectrum Transmitter
Description of EUT:	Video Monitor - Parent unit
Brand Name:	VTech
Sample Receipt Date:	July 20, 2023
Date of Test:	August 17, 2023 to August 24, 2023
Report Date:	September 04, 2023
Environmental Conditions:	Temperature: +10 to 40°C Relative Humidity: 10 to 90%
Conclusion:	Test was conducted by client submitted sample. The submitted sample as received complied with the 47 CFR Part 15 / RSS-247 Issue 3 Certification.

TEST REPORT

SUMMARY OF TEST RESULT

Test Items	FCC Part 15 Section	RSS-247 / RSS-Gen [#] Section	Results
Antenna Requirement	15.203	7.1.2 [#]	Complied
Max. Conducted Output Power (Peak)	15.247(b)(3)&(4)	5.4(4)	Complied
Min. 6dB RF Bandwidth	15.247(a)(2)	5.2(1)	Complied
Max. Power Density (Average)	15.247(e)	5.2(2)	Complied
Out of Band Antenna Conducted Emission	15.247(d)	5.5	Complied
Radiated Emission in Restricted Bands and Spurious Emissions	15.247(d), 15.209 & 15.109	5.5	Complied
AC Power Line Conducted Emission	15.207 & 15.107	7.2.4 [#]	Complied

Note: Pursuant to FCC Part 15 Section 15.215(c), the 20dB bandwidth of the emission was contained within the frequency band designated (mentioned as above) which the EUT operated. The effects, if any, from frequency sweeping, frequency hopping, other modulation techniques and frequency stability over expected variations in temperature and supply voltage were considered.

For all technical data, which can be referred to Annex B – Report cover sheet.

For electronic filing, the Annex B – Report cover sheet is saved with filename: Annex B.pdf.

The equipment under test is found to be complying with the following standards:

FCC Part 15, October 1, 2021 Edition

RSS-247 Issue 3, August 2023

RSS-Gen Issue 5 Amendment 2, February 2021

TEST REPORT

TABLE OF CONTENTS

EXHIBIT 1 GENERAL DESCRIPTION 5

 1.1 Product Description.....5

 1.2 Test Methodology5

 1.3 Test Facility.....5

 1.4 Related Submittal(s) Grants5

EXHIBIT 2 SYSTEM TEST CONFIGURATION 6

 2.1 Justification6

 2.2 EUT Exercising Software7

 2.3 Details of EUT and Description of Accessories8

 2.4 Measurement Uncertainty8

EXHIBIT 3 TEST RESULTS 9

 3.1 Maximum Conducted (Peak) Output Power at Antenna Terminals9

 3.2 Minimum 6dB RF Bandwidth.....11

 3.3 Minimum Power Spectral Density12

 3.4 Out of Band Conducted Emissions13

 3.5 Field Strength Calculation14

 3.6 Transmitter Radiated Emissions in Restricted Bands and Spurious Emissions15

 3.7 Transmitter Duty Cycle Calculation27

 3.8 AC Power Line Conducted Emission27

EXHIBIT 4 EQUIPMENT LIST 33

TEST REPORT

EXHIBIT 1 GENERAL DESCRIPTION

1.1 Product Description

The RM5756HD PU (35-400370PUA) is a Video Baby Monitor - Parent Unit.

The Equipment Under Test (EUT) operates at frequency range of 2412 MHz to 2462 MHz with 11 channels.

For IEEE 802.11b mode, it operates at frequency range of 2412.000 MHz to 2462.000 MHz with 11 channels. It transmits via Direct-sequence spread spectrum (DSSS) modulation. Maximum bit rate can be up to 11Mbps.

For IEEE 802.11g mode, it operates at frequency range of 2412.000 MHz to 2462.000 MHz with 11 channels. It transmits via Orthogonal Frequency Division Multiplexing (OFDM) modulation. Maximum bit rate can be up to 54Mbps.

For IEEE 802.11n (with 20 MHz bandwidth) mode, it operates at frequency range of 2412.000 MHz to 2462.000 MHz with 11 channels. It transmits via Orthogonal Frequency Division Multiplexing (OFDM) modulation. Maximum bit rate can support up to 65Mbps.

The EUT is powered by 100-240VAC 50/60Hz 0.5A adaptor.

The antenna(s) used in the EUT is integral, and the test sample is a prototype.

Peak Antenna Gain: 2dBi

For FCC, the Model(s): RM5756-2HD PU, RM5756-abHD PU, RM5856HD PU, RM5856-2HD PU are the same as the Model: RM5756HD PU in electronics/electrical designs including software & firmware, PCB layout and construction design/physical design/enclosure. The only differences between these models are color to be sold for marketing purpose as declared by client.

The circuit description is saved with filename: descri.pdf.

1.2 Test Methodology

Both AC power line-conducted and radiated emission measurements were performed according to the procedures in ANSI C63.10 (2013). Preliminary radiated scans and all radiated measurements were performed in radiated emission test sites. All Radiated tests were performed at an antenna to EUT distance of 3 meters, unless stated otherwise in the "**Justification Section**" of this Application. Antenna port conducted measurements were performed according to ANSI C63.10 (2013) and KDB Publication No. 558074 D01 v05r02 (April 02, 2019) All other measurements were made in accordance with the procedures in 47 CFR Part 2 and RSS-Gen Issue 5 Amendment 2, February 2021.

1.3 Test Facility

The radiated emission test site and antenna port conducted measurement facility used to collect the radiated data and conductive data are at Workshop No. 3, G/F., World-Wide Industrial Centre, 43-47 Shan Mei Street, Fo Tan, Sha Tin, N.T., Hong Kong SAR, China. This test facility and site measurement data have been fully placed on file with the FCC and Industry Canada No.: 2042H, CABID is "HKAP01".

1.4 Related Submittal(s) Grants

This is a single application for certification of a transceiver (WiFi Portion).

TEST REPORT

EXHIBIT 2 SYSTEM TEST CONFIGURATION

2.1 Justification

For radiated emissions testing, the equipment under test (EUT) was setup to transmit / receive continuously to simplify the measurement methodology. Care was taken to ensure proper power supply voltages during testing. During testing, all cables (if any) were manipulated to produce worst case emissions.

The EUT was powered by 120VAC during test.

For the measurements, the EUT was attached to a plastic stand if necessary and placed on the wooden turntable at 0.8m height from the ground plane for emission testing at or below 1GHz and 1.5m for emission measurements above 1GHz. If the baby unit attached to peripherals, they were connected and operational (as typical as possible). The parent unit was remotely located as far from the antenna and the baby as possible to ensure full power transmission from the parent unit. Else, the base was wired to transmit full power with modulation.

The signal was maximized through rotation and placement in the three orthogonal axes. The antenna height and polarization were varied during the search for maximum signal level. The antenna height was varied from 1 to 4 meters. Radiated emissions were taken at three meters unless the signal level was too low for measurement at that distance. If necessary, a pre-amplifier was used and/or the test was conducted at a closer distance.

For any intentional radiator powered by AC power line, measurements of the radiated signal level of the fundamental frequency component of the emission was performed with the supply voltage varied between 85% and 115% of the nominal rated supply voltage.

Radiated emission measurement for transmitter were performed from the lowest radio frequency signal generated in the device which is greater than 9 kHz to the tenth harmonic of the highest fundamental frequency or to 40 GHz, whichever is lower.

Emission that are directly caused by digital circuits in the transmit path and transmitter portion were measured, and the limit are according to FCC Part 15 Section 15.209 / RSS-247 2.5. Digital circuitries used to control additional functions other than the operation of the transmitter are subject to FCC Part 15 Section 15.109 / RSS-247 Section 5.5 Limits.

TEST REPORT

2.1 Justification (Cont'd)

Detector function for radiated emissions was in peak mode. Average readings, when required, were taken by measuring the duty cycle of the equipment under test and subtracting the corresponding amount in dB from the measured peak readings. A detailed description for the calculation of the average factor can be found in section 4.8.3.

Determination of pulse desensitization was made according to *Hewlett Packard Application Note 150-2, Spectrum Analysis... Pulsed RF*. The effective period (Teff) was referred to Exhibit 4.8.3. With the resolution bandwidth 1MHz and spectrum analyzer IF bandwidth 3dB, the pulse desensitization factor was 0dB.

For AC power line-conducted emission test, the EUT along with its peripherals were placed on a 1.0m(W)x1.5m(L) and 0.8m in height wooden table and the EUT was adjusted to maintain a 0.4 meter space from a vertical reference plane. The EUT was connected to power mains through a line impedance stabilization network (LISN), which provided 50ohm coupling impedance for measuring instrument. The LISN housing, measuring instrument case, reference ground plane, and vertical ground plane were bounded together. The excess power cable between the EUT and the LISN was bundled.

All connecting cables of EUT and peripherals were manipulated to find the maximum emission.

All relevant operation modes have been tested, and the worst-case data is included in this report.

All data rates were tested under normal mode of WiFi. Only the worst-case data is shown in the report for DSSS and OFDM.

2.2 EUT Exercising Software

The EUT exercise program (Tera Terms Version 4.106) used during radiated and conducted testing was designed to exercise the various system components in a manner similar to a typical use.

TEST REPORT

2.3 Details of EUT and Description of Accessories

Details of EUT:

An AC/DC Adaptor (provided with the unit) was used to power the device.
Their descriptions are listed below.

- (1) An AC adaptor (Model: VT07EUS05200; Brand Name: VTPL; Input: 100-240VAC 50/60Hz 0.5A; Output: 5.0VDC 2.0A 10.0W) (Provided by Applicant)

Description of Accessories:

- (1) Baby Unit (FCC ID: EW780-2634-00A) (Provided by Applicant)

2.4 Measurement Uncertainty

Decision Rule for compliance: For FCC/IC standard, the measured value must be within the limits of applicable standard without accounting for the measurement uncertainty. For EN/IEC/HKTA/HKTC standard, conformity rules will be used as per standard directly excepted EN/IEC 61000-3-2, EN/IEC 61000-3-3, HKTA1004, HKCA1008, HKTA1019, HKTA1020, HKTA1041 and HKTA1044. For these excepted or not mentioned standards, Cl 4.2.2 of ILAC-G8:09/2019 decision rules will be reference and guard band will be equal to our measurement uncertainty with 95% confidence level (k=2). In case, the measured value is within guard band region, undetermined decision will be used.

Uncertainty and Compliance - Unless the standard specifically states that measured values are to be extended by the measurement uncertainty in determining compliance, all compliance determinations are based on the actual measured value.

TEST REPORT

EXHIBIT 3 TEST RESULTS

3.1 Maximum Conducted (Peak) Output Power at Antenna Terminals

RF Conduct Measurement Test Setup

The figure below shows the test setup, which is utilized to make these measurements.

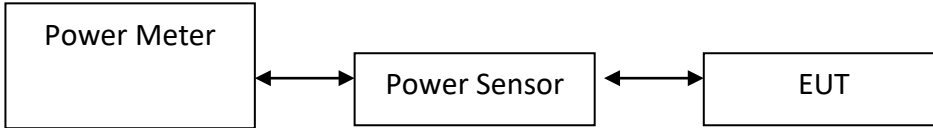

The antenna port of the EUT was connected to the input of a spectrum analyzer.

- The antenna power of the EUT was connected to the input of a power meter. Power was read directly and cable loss correction was added to the reading to obtain power at the EUT antenna terminals. The measurement procedure 8.3.2.3 was used.
- The EUT should be configured to transmit continuously (at a minimum duty cycle of 98%) at full power over the measurement duration. The measurement procedure AVG1 was used.

IEEE 802.11b (DSSS, 1 Mbps) Peak Antenna Gain = 2 dBi

	Frequency (MHz)	Output in dBm	Output in mW
Low Channel:	2412	13.3	21.4
Middle Channel:	2437	13.8	24.0
High Channel:	2462	13.5	22.4

IEEE 802.11g (OFDM, 6 Mbps) Peak Antenna Gain = 2 dBi

	Frequency (MHz)	Output in dBm	Output in mW
Low Channel:	2412	11.7	14.8
Middle Channel:	2437	12.1	16.2
High Channel:	2462	11.7	14.8

IEEE 802.11n (20MHz) (OFDM, MCS0) Peak Antenna Gain = 2 dBi

	Frequency (MHz)	Output in dBm	Output in mW
Low Channel:	2412	9.6	9.1
Middle Channel:	2437	10.5	11.2
High Channel:	2462	10.0	10.0

TEST REPORT**3.1 Maximum Conducted (Peak) Output Power at Antenna Terminals (Cont'd)**

Cable loss: 0.5 dB External Attenuation: 0 dB

Cable loss, external attenuation: included in OFFSET function
 added to SA raw reading

IEEE 802.11b (DSSS, 1 Mbps)

Max. Conducted (Peak) Output Level = 13.8 dBm

IEEE 802.11g (OFDM, 6 Mbps)

Max. Conducted (Peak) Output Level = 12.1 dBm

IEEE 802.11n (20MHz) (OFDM, MCS0)

Max. Conducted (Peak) Output Level = 10.5 dBm

Limits:

1W (30dBm) for antennas with gains of 6dBi or less.

The plots of Conducted (Peak) Output Power at Antenna Terminals are saved with filename:
test data.pdf

TEST REPORT**3.2 Minimum 6dB RF Bandwidth**

The antenna port of the EUT was connected to the input of a spectrum analyzer. The EBW measurement procedure was used. A PEAK output reading was taken, a DISPLAY line was drawn 6dB lower than PEAK level. The 6dB bandwidth was determined from where the channel output spectrum intersected the display line.

IEEE 802.11b (DSSS, 1 Mbps)

Frequency (MHz)	6dB Bandwidth (MHz)
Low Channel: 2412	9.1
Middle Channel: 2437	9.1
High Channel: 2462	9.2

IEEE 802.11g (OFDM, 6 Mbps)

Frequency (MHz)	6dB Bandwidth (MHz)
Low Channel: 2412	16.7
Middle Channel: 2437	16.6
High Channel: 2462	16.6

IEEE 802.11n (20MHz) (OFDM, MCS0)

Frequency (MHz)	6dB Bandwidth (MHz)
Low Channel: 2412	18.0
Middle Channel: 2437	17.9
High Channel: 2462	18.0

Limits:

6dB bandwidth shall be at least 500kHz.

The plots of 6dB RF Bandwidth are saved with filename: test data.pdf

TEST REPORT**3.3 Minimum Power Spectral Density**

Antenna output of the EUT was coupled directly to spectrum analyzer. The measurement procedure 10.2 PKPSD was used. If an external attenuator and/or cable was used, these losses are compensated for using the OFFSET function of the analyser.

IEEE 802.11b (DSSS, 1 Mbps)

Frequency (MHz)		PSD in 100kHz (dBm)
Low Channel:	2412	3.596
Middle Channel:	2437	4.001
High Channel:	2462	3.870

IEEE 802.11g (OFDM, 6 Mbps)

Frequency (MHz)		PSD in 100kHz (dBm)
Low Channel:	2412	-2.966
Middle Channel:	2437	-2.568
High Channel:	2462	-2.924

IEEE 802.11n (20MHz) (OFDM, MCS0)

Frequency (MHz)		PSD in 100kHz (dBm)
Low Channel:	2412	-4.899
Middle Channel:	2437	-3.709
High Channel:	2462	-4.055

Cable Loss: 0.5dB

Limit: 8dBm in 3kHz

The plots of Power Spectral Density are saved with filename: test data.pdf

TEST REPORT

3.4 Out of Band Conducted Emissions

For IEEE 802.11b/g/n20MHz, the maximum conducted (peak) output power was used to demonstrate compliance as described in 9.1. Then the display line (in red) shown in the following plots denotes the limit at 20dB below maximum measured in-band peak PSD level in 100 KHz bandwidth for IEEE 802.11b/g/n20MHz.

The measurement procedures under sections 11 of KDB558074 D01 v05r02 (April 2, 2019) were used.

Furthermore, delta measurement technique for measuring bandedge emissions was incorporated in the test of the edge at 2483.5MHz.

Limits:

All spurious emission and up to the tenth harmonic was measured and they were found to be at least 20dB below the maximum measured in-band peak PSD level for IEEE 802.11b/g/n20MHz.

The plots of Out of Band Conducted Emissions are saved with filename: test data.pdf

TEST REPORT

3.5 Field Strength Calculation

The field strength is calculated by adding the reading on the Spectrum Analyzer to the factors associated with preamplifiers (if any), antennas, cables, pulse desensitization and average factors (when specified limit is in average and measurements are made with peak detectors). A sample calculation is included below.

$$FS = RA + AF + CF - AG + PD + AV$$

Where	FS	=	Field Strength in dB μ V/m
	RA	=	Receiver Amplitude (including preamplifier) in dB μ V
	CF	=	Cable Attenuation Factor in dB
	AF	=	Antenna Factor in dB
	AG	=	Amplifier Gain in dB
	PD	=	Pulse Desensitization in dB
	AV	=	Average Factor in -dB

In the radiated emission table which follows, the reading shown on the data table may reflect the preamplifier gain. An example of the calculations, where the reading does not reflect the preamplifier gain, follows:

$$FS = RA + AF + CF - AG + PD + AV$$

Example:

Assume a receiver reading of 62.0 dB μ V is obtained. The antenna factor of 7.4 dB and cable factor of 1.6 dB is added. The amplifier gain of 29.0 dB is subtracted. The pulse desensitization factor of the spectrum analyzer is 0.0 dB, and the resultant average factor is -10.0 dB. The net field strength for comparison to the appropriate emission limit is 32.0 dB μ V/m. This value in dB μ V/m is converted to its corresponding level in μ V/m.

RA	=	62.0 dB μ V
AF	=	7.4 dB
CF	=	1.6 dB
AG	=	29.0 dB
PD	=	0.0 dB
AV	=	-10.0 dB
FS	=	$62.0 + 7.4 + 1.6 - 29.0 + 0.0 + -10.0 = 32.0$ dB μ V/m

$$\text{Level in } \mu\text{V/m} = \text{Common Antilogarithm } [(32.0 \text{ dB}\mu\text{V/m})/20] = 39.8 \mu\text{V/m}$$

TEST REPORT

3.6 Transmitter Radiated Emissions in Restricted Bands and Spurious Emissions

Data is included of the worst-case configuration (the configuration which resulted in the highest emission levels). A sample calculation, configuration photographs and data tables of the emissions are included.

The data on the following pages list the significant emission frequencies, the limit and the margin of compliance.

3.6.1 Radiated Emission Configuration Photograph

Worst Case Restricted Band Radiated Emission at 2390 MHz.

The worst case radiated emission configuration photographs are saved with filename:
Setup Photos.pdf

3.6.2 Radiated Emission Data

The data in tables 1-10 list the significant emission frequencies, the limit and the margin of compliance.

Judgement – Passed by 0.1 dB margin

TEST REPORT

3.6.3 Radiated Emission Test Setup

The figure below shows the test setup, which is utilized to make these measurements.

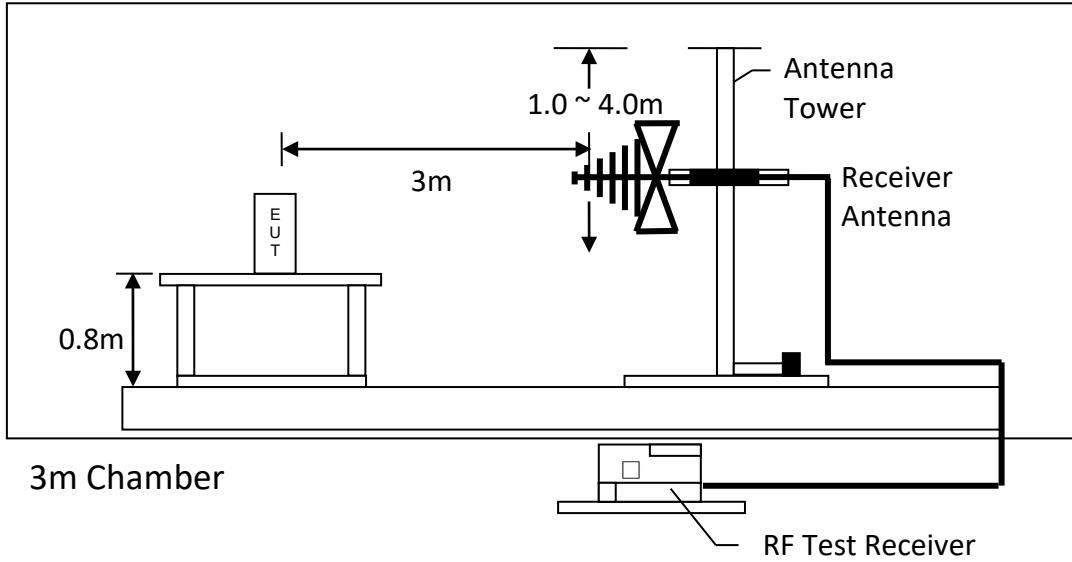

Test setup of radiated emissions up to 1GHz

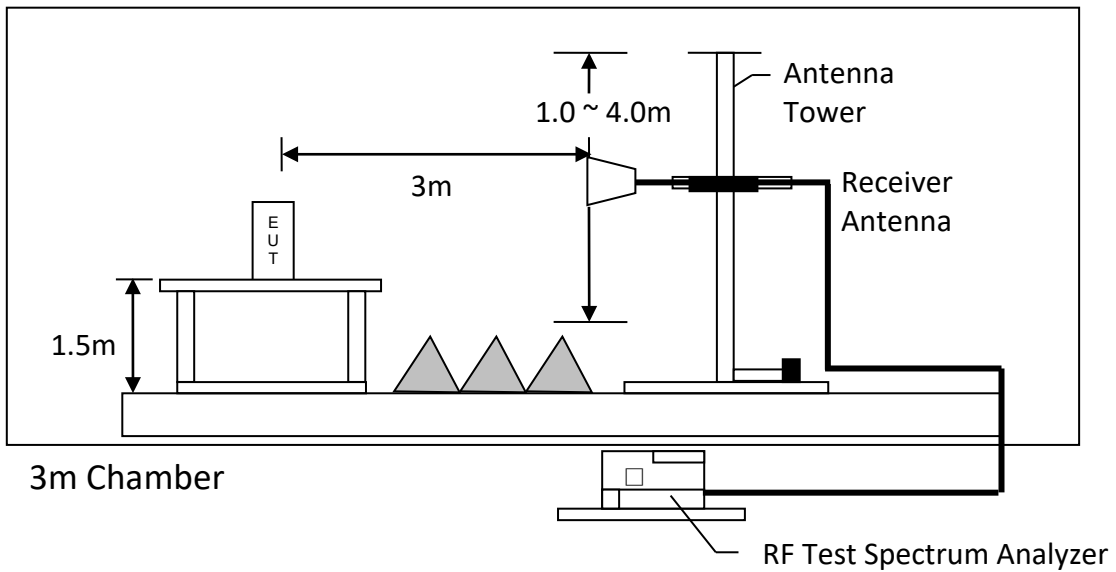

Test setup of radiated emissions above 1GHz

TEST REPORT

RADIATED EMISSION DATA

Mode: TX-Channel 01

Table 1, IEEE 802.11b DSSS 1Mbps

Polarization	Frequency (MHz)	Reading (dB μ V)	Pre-Amp Gain (dB)	Antenna Factor (dB)	Net at 3m (average) (dB μ V/m)	Average Limit at 3m (dB μ V/m)	Margin (dB)
V	2390.000	50.7	33	29.4	47.1	54.0	-6.9
V	4824.000	49.1	33	34.9	51.0	54.0	-3.0
V	7236.000	35.0	33	37.9	39.9	54.0	-14.1
V	9648.000	30.8	33	40.4	38.2	54.0	-15.8
H	12060.000	29.5	33	40.5	37.0	54.0	-17.0
V	14472.000	34.2	33	40.0	41.2	54.0	-12.8

Polarization	Frequency (MHz)	Reading (dB μ V)	Pre-Amp Gain (dB)	Antenna Factor (dB)	Net at 3m - Peak (dB μ V/m)	Peak Limit at 3m (dB μ V/m)	Margin (dB)
V	2390.000	61.5	33	29.4	57.9	74.0	-16.1
V	4824.000	52.0	33	34.9	53.9	74.0	-20.1
V	7236.000	46.2	33	37.9	51.1	74.0	-22.9
V	9648.000	42.5	33	40.4	49.9	74.0	-24.1
H	12060.000	43.3	33	40.5	50.8	74.0	-23.2
V	14472.000	48.0	33	40.0	55.0	74.0	-19.0

- Notes:
1. Peak detector is used for the emission measurement.
 2. Average detector is used for the average data of emission measurement.
 3. All measurements were made at 3 meters.
 4. Negative value in the margin column shows emission below limit.
 5. Horn antenna is used for the emission over 1000MHz.
 6. Emissions within the restricted band meets the requirement of FCC Part 15 Section 15.205 / RSS-Gen Section 8.10.
 7. Measurement Uncertainty is ± 5.3 dB at a level of confidence of 95%.
 8. For the measurement of radiated emission, summation method was used which numerical integrating (in terms of linear power) over the transmitter occupied bandwidth.
 9. For the linear power measurement, data in 1MHz spacing was collected by spectrum analyzer with 1MHz resolution bandwidth.

TEST REPORT

RADIATED EMISSION DATA

Mode: TX-Channel 06

Table 2, IEEE 802.11b DSSS 1Mbps

Polarization	Frequency (MHz)	Reading (dB μ V)	Pre-Amp Gain (dB)	Antenna Factor (dB)	Net at 3m (average) (dB μ V/m)	Average Limit at 3m (dB μ V/m)	Margin (dB)
V	4874.000	41.3	33	34.9	43.2	54.0	-10.8
V	7311.000	30.8	33	37.9	35.7	54.0	-18.3
H	9748.000	33.8	33	40.4	41.2	54.0	-12.8
V	12185.000	30.0	33	40.5	37.5	54.0	-16.5
H	14622.000	35.5	33	38.4	40.9	54.0	-13.1

Polarization	Frequency (MHz)	Reading (dB μ V)	Pre-Amp Gain (dB)	Antenna Factor (dB)	Net at 3m - Peak (dB μ V/m)	Peak Limit at 3m (dB μ V/m)	Margin (dB)
V	4874.000	46.9	33	34.9	48.8	74.0	-25.2
V	7311.000	42.9	33	37.9	47.8	74.0	-26.2
H	9748.000	43.8	33	40.4	51.2	74.0	-22.8
V	12185.000	42.9	33	40.5	50.4	74.0	-23.6
H	14622.000	49.0	33	38.4	54.4	74.0	-19.6

- Notes:
1. Peak detector is used for the emission measurement.
 2. Average detector is used for the average data of emission measurement.
 3. All measurements were made at 3 meters.
 4. Negative value in the margin column shows emission below limit.
 5. Horn antenna is used for the emission over 1000MHz.
 6. Emissions within the restricted band meets the requirement of FCC Part 15 Section 15.205 / RSS-Gen Section 8.10.
 7. Measurement Uncertainty is ± 5.3 dB at a level of confidence of 95%.
 8. For the measurement of radiated emission, summation method was used which numerical integrating (in terms of linear power) over the transmitter occupied bandwidth.
 9. For the linear power measurement, data in 1MHz spacing was collected by spectrum analyzer with 1MHz resolution bandwidth.

TEST REPORT

RADIATED EMISSION DATA

Mode: TX-Channel 11

Table 3, IEEE 802.11b DSSS 1Mbps

Polarization	Frequency (MHz)	Reading (dB μ V)	Pre-Amp Gain (dB)	Antenna Factor (dB)	Net at 3m (average) (dB μ V/m)	Average Limit at 3m (dB μ V/m)	Margin (dB)
V	2483.500	45.4	33	29.4	41.8	54.0	-12.2
V	4924.000	39.9	33	34.9	41.8	54.0	-12.2
H	7386.000	27.4	33	37.9	32.3	54.0	-21.7
V	9848.000	33.9	33	40.4	41.3	54.0	-12.7
H	12310.000	29.9	33	40.5	37.4	54.0	-16.6
H	14772.000	34.8	33	38.4	40.2	54.0	-13.8

Polarization	Frequency (MHz)	Reading (dB μ V)	Pre-Amp Gain (dB)	Antenna Factor (dB)	Net at 3m - Peak (dB μ V/m)	Peak Limit at 3m (dB μ V/m)	Margin (dB)
V	2483.500	59.1	33	29.4	55.5	74.0	-18.5
V	4924.000	45.9	33	34.9	47.8	74.0	-26.2
H	7386.000	41.0	33	37.9	45.9	74.0	-28.1
V	9848.000	43.8	33	40.4	51.2	74.0	-22.8
H	12310.000	43.0	33	40.5	50.5	74.0	-23.5
H	14772.000	48.1	33	38.4	53.5	74.0	-20.5

- Notes:
1. Peak detector is used for the emission measurement.
 2. Average detector is used for the average data of emission measurement.
 3. All measurements were made at 3 meters.
 4. Negative value in the margin column shows emission below limit.
 5. Horn antenna is used for the emission over 1000MHz.
 6. Emissions within the restricted band meets the requirement of FCC Part 15 Section 15.205 / RSS-Gen Section 8.10.
 7. Measurement Uncertainty is ± 5.3 dB at a level of confidence of 95%.
 8. For the measurement of radiated emission, summation method was used which numerical integrating (in terms of linear power) over the transmitter occupied bandwidth.
 9. For the linear power measurement, data in 1MHz spacing was collected by spectrum analyzer with 1MHz resolution bandwidth.

TEST REPORT

RADIATED EMISSION DATA

Mode: TX-Channel 01

Table 4, IEEE 802.11g OFDM, 6 Mbps

Polarization	Frequency (MHz)	Reading (dBμV)	Pre-Amp Gain (dB)	Antenna Factor (dB)	Net at 3m (average) (dBμV/m)	Average Limit at 3m (dBμV/m)	Margin (dB)
V	2390.000	57.4	33	29.4	53.8	54.0	-0.2
V	4824.000	32.1	33	34.9	34.0	54.0	-20.0
H	7236.000	28.4	33	37.9	33.3	54.0	-20.7
H	9648.000	28.7	33	40.4	36.1	54.0	-17.9
H	12060.000	29.5	33	40.5	37.0	54.0	-17.0
H	14472.000	34.2	33	40.0	41.2	54.0	-12.8

Polarization	Frequency (MHz)	Reading (dBμV)	Pre-Amp Gain (dB)	Antenna Factor (dB)	Net at 3m - Peak (dBμV/m)	Peak Limit at 3m (dBμV/m)	Margin (dB)
V	2390.000	77.4	33	29.4	73.8	74.0	-0.2
V	4824.000	45.5	33	34.9	47.4	74.0	-26.6
H	7236.000	42.0	33	37.9	46.9	74.0	-27.1
H	9648.000	41.4	33	40.4	48.8	74.0	-25.2
H	12060.000	43.3	33	40.5	50.8	74.0	-23.2
H	14472.000	47.7	33	40.0	54.7	74.0	-19.3

- Notes:
1. Peak detector is used for the emission measurement.
 2. Average detector is used for the average data of emission measurement.
 3. All measurements were made at 3 meters.
 4. Negative value in the margin column shows emission below limit.
 5. Horn antenna is used for the emission over 1000MHz.
 6. Emissions within the restricted band meets the requirement of FCC Part 15 Section 15.205 / RSS-Gen Section 8.10.
 7. Measurement Uncertainty is ±5.3dB at a level of confidence of 95%.
 8. For the measurement of radiated emission, summation method was used which numerical integrating (in terms of linear power) over the transmitter occupied bandwidth.
 9. For the linear power measurement, data in 1MHz spacing was collected by spectrum analyzer with 1MHz resolution bandwidth.

TEST REPORT

RADIATED EMISSION DATA

Mode: TX-Channel 06

Table 5, IEEE 802.11g OFDM, 6 Mbps

Polarization	Frequency (MHz)	Reading (dBμV)	Pre-Amp Gain (dB)	Antenna Factor (dB)	Net at 3m (average) (dBμV/m)	Average Limit at 3m (dBμV/m)	Margin (dB)
V	4874.000	29.3	33	34.9	31.2	54.0	-22.8
V	7311.000	31.1	33	37.9	36.0	54.0	-18.0
H	9748.000	32.7	33	40.4	40.1	54.0	-13.9
V	12185.000	30.0	33	40.5	37.5	54.0	-16.5
V	14622.000	35.7	33	38.4	41.1	54.0	-12.9

Polarization	Frequency (MHz)	Reading (dBμV)	Pre-Amp Gain (dB)	Antenna Factor (dB)	Net at 3m - Peak (dBμV/m)	Peak Limit at 3m (dBμV/m)	Margin (dB)
V	4874.000	42.4	33	34.9	44.3	74.0	-29.7
V	7311.000	45.2	33	37.9	50.1	74.0	-23.9
H	9748.000	43.5	33	40.4	50.9	74.0	-23.1
V	12185.000	43.5	33	40.5	51.0	74.0	-23.0
V	14622.000	49.3	33	38.4	54.7	74.0	-19.3

- Notes:
1. Peak detector is used for the emission measurement.
 2. Average detector is used for the average data of emission measurement.
 3. All measurements were made at 3 meters.
 4. Negative value in the margin column shows emission below limit.
 5. Horn antenna is used for the emission over 1000MHz.
 6. Emissions within the restricted band meets the requirement of FCC Part 15 Section 15.205 / RSS-Gen Section 8.10.
 7. Measurement Uncertainty is ±5.3dB at a level of confidence of 95%.
 8. For the measurement of radiated emission, summation method was used which numerical integrating (in terms of linear power) over the transmitter occupied bandwidth.
 9. For the linear power measurement, data in 1MHz spacing was collected by spectrum analyzer with 1MHz resolution bandwidth.

TEST REPORT

RADIATED EMISSION DATA

Mode: TX-Channel 11

Table 6, IEEE 802.11g OFDM, 6 Mbps

Polarization	Frequency (MHz)	Reading (dBμV)	Pre-Amp Gain (dB)	Antenna Factor (dB)	Net at 3m (average) (dBμV/m)	Average Limit at 3m (dBμV/m)	Margin (dB)
V	2483.500	45.8	33	29.4	42.2	54.0	-11.8
V	4924.000	28.8	33	34.9	30.7	54.0	-23.3
V	7386.000	29.3	33	37.9	34.2	54.0	-19.8
H	9848.000	28.8	33	40.4	36.2	54.0	-17.8
H	12310.000	29.7	33	40.5	37.2	54.0	-16.8
H	14772.000	35.0	33	38.4	40.4	54.0	-13.6

Polarization	Frequency (MHz)	Reading (dBμV)	Pre-Amp Gain (dB)	Antenna Factor (dB)	Net at 3m - Peak (dBμV/m)	Peak Limit at 3m (dBμV/m)	Margin (dB)
V	2483.500	58.5	33	29.4	54.9	74.0	-19.1
V	4924.000	42.4	33	34.9	44.3	74.0	-29.7
V	7386.000	43.3	33	37.9	48.2	74.0	-25.8
H	9848.000	42.8	33	40.4	50.2	74.0	-23.8
H	12310.000	43.3	33	40.5	50.8	74.0	-23.2
H	14772.000	48.1	33	38.4	53.5	74.0	-20.5

- Notes:
1. Peak detector is used for the emission measurement.
 2. Average detector is used for the average data of emission measurement.
 3. All measurements were made at 3 meters.
 4. Negative value in the margin column shows emission below limit.
 5. Horn antenna is used for the emission over 1000MHz.
 6. Emissions within the restricted band meets the requirement of FCC Part 15 Section 15.205 / RSS-Gen Section 8.10.
 7. Measurement Uncertainty is ±5.3dB at a level of confidence of 95%.
 8. For the measurement of radiated emission, summation method was used which numerical integrating (in terms of linear power) over the transmitter occupied bandwidth.
 9. For the linear power measurement, data in 1MHz spacing was collected by spectrum analyzer with 1MHz resolution bandwidth.

TEST REPORT

RADIATED EMISSION DATA

Mode: TX-Channel 01

Table 7, IEEE 802.11n (20MHz) OFDM, MCS0

Polarization	Frequency (MHz)	Reading (dBμV)	Pre-Amp Gain (dB)	Antenna Factor (dB)	Net at 3m (average) (dBμV/m)	Average Limit at 3m (dBμV/m)	Margin (dB)
V	2390.000	57.5	33	29.4	53.9	54.0	-0.1
V	4824.000	32.0	33	34.9	33.9	54.0	-20.1
V	7236.000	31.8	33	37.9	36.7	54.0	-17.3
H	9648.000	29.3	33	40.4	36.7	54.0	-17.3
V	12060.000	29.6	33	40.5	37.1	54.0	-16.9
V	14472.000	34.2	33	40.0	41.2	54.0	-12.8

Polarization	Frequency (MHz)	Reading (dBμV)	Pre-Amp Gain (dB)	Antenna Factor (dB)	Net at 3m - Peak (dBμV/m)	Peak Limit at 3m (dBμV/m)	Margin (dB)
V	2390.000	77.1	33	29.4	73.5	74.0	-0.5
V	4824.000	44.9	33	34.9	46.8	74.0	-27.2
V	7236.000	47.0	33	37.9	51.9	74.0	-22.1
H	9648.000	42.0	33	40.4	49.4	74.0	-24.6
V	12060.000	44.1	33	40.5	51.6	74.0	-22.4
V	14472.000	47.7	33	40.0	54.7	74.0	-19.3

- Notes:
1. Peak detector is used for the emission measurement.
 2. Average detector is used for the average data of emission measurement.
 3. All measurements were made at 3 meters.
 4. Negative value in the margin column shows emission below limit.
 5. Horn antenna is used for the emission over 1000MHz.
 6. Emissions within the restricted band meets the requirement of FCC Part 15 Section 15.205 / RSS-Gen Section 8.10.
 7. Measurement Uncertainty is ± 5.3 dB at a level of confidence of 95%.
 8. For the measurement of radiated emission, summation method was used which numerical integrating (in terms of linear power) over the transmitter occupied bandwidth.
 9. For the linear power measurement, data in 1MHz spacing was collected by spectrum analyzer with 1MHz resolution bandwidth.

TEST REPORT

RADIATED EMISSION DATA

Mode: TX-Channel 06

Table 8, IEEE 802.11n (20MHz) OFDM, MCS0

Polarization	Frequency (MHz)	Reading (dB μ V)	Pre-Amp Gain (dB)	Antenna Factor (dB)	Net at 3m (average) (dB μ V/m)	Average Limit at 3m (dB μ V/m)	Margin (dB)
V	4874.000	28.4	33	34.9	30.3	54.0	-23.7
V	7311.000	28.7	33	37.9	33.6	54.0	-20.4
H	9748.000	28.7	33	40.4	36.1	54.0	-17.9
H	12185.000	30.0	33	40.5	37.5	54.0	-16.5
H	14622.000	35.6	33	38.4	41.0	54.0	-13.0

Polarization	Frequency (MHz)	Reading (dB μ V)	Pre-Amp Gain (dB)	Antenna Factor (dB)	Net at 3m - Peak (dB μ V/m)	Peak Limit at 3m (dB μ V/m)	Margin (dB)
V	4874.000	42.3	33	34.9	44.2	74.0	-29.8
V	7311.000	43.0	33	37.9	47.9	74.0	-26.1
H	9748.000	41.6	33	40.4	49.0	74.0	-25.0
H	12185.000	43.7	33	40.5	51.2	74.0	-22.8
H	14622.000	48.9	33	38.4	54.3	74.0	-19.7

- Notes:
1. Peak detector is used for the emission measurement.
 2. Average detector is used for the average data of emission measurement.
 3. All measurements were made at 3 meters.
 4. Negative value in the margin column shows emission below limit.
 5. Horn antenna is used for the emission over 1000MHz.
 6. Emissions within the restricted band meets the requirement of FCC Part 15 Section 15.205 / RSS-Gen Section 8.10.
 7. Measurement Uncertainty is ± 5.3 dB at a level of confidence of 95%.
 8. For the measurement of radiated emission, summation method was used which numerical integrating (in terms of linear power) over the transmitter occupied bandwidth.
 9. For the linear power measurement, data in 1MHz spacing was collected by spectrum analyzer with 1MHz resolution bandwidth.

TEST REPORT

RADIATED EMISSION DATA

Mode: TX-Channel 11

Table 9, IEEE 802.11n (20MHz) OFDM, MCS0

Polarization	Frequency (MHz)	Reading (dB μ V)	Pre-Amp Gain (dB)	Antenna Factor (dB)	Net at 3m (average) (dB μ V/m)	Average Limit at 3m (dB μ V/m)	Margin (dB)
V	2483.500	45.7	33	29.4	42.1	54.0	-11.9
V	4924.000	27.8	33	34.9	29.7	54.0	-24.3
H	7386.000	27.7	33	37.9	32.6	54.0	-21.4
V	9848.000	30.5	33	40.4	37.9	54.0	-16.1
V	12310.000	29.7	33	40.5	37.2	54.0	-16.8
H	14772.000	35.0	33	38.4	40.4	54.0	-13.6

Polarization	Frequency (MHz)	Reading (dB μ V)	Pre-Amp Gain (dB)	Antenna Factor (dB)	Net at 3m - Peak (dB μ V/m)	Peak Limit at 3m (dB μ V/m)	Margin (dB)
V	2483.500	59.4	33	29.4	55.8	74.0	-18.2
V	4924.000	41.0	33	34.9	42.9	74.0	-31.1
H	7386.000	42.2	33	37.9	47.1	74.0	-26.9
V	9848.000	42.7	33	40.4	50.1	74.0	-23.9
V	12310.000	43.8	33	40.5	51.3	74.0	-22.7
H	14772.000	48.4	33	38.4	53.8	74.0	-20.2

- Notes:
1. Peak detector is used for the emission measurement.
 2. Average detector is used for the average data of emission measurement.
 3. All measurements were made at 3 meters.
 4. Negative value in the margin column shows emission below limit.
 5. Horn antenna is used for the emission over 1000MHz.
 6. Emissions within the restricted band meets the requirement of FCC Part 15 Section 15.205 / RSS-Gen Section 8.10.
 7. Measurement Uncertainty is ± 5.3 dB at a level of confidence of 95%.
 8. For the measurement of radiated emission, summation method was used which numerical integrating (in terms of linear power) over the transmitter occupied bandwidth.
 9. For the linear power measurement, data in 1MHz spacing was collected by spectrum analyzer with 1MHz resolution bandwidth.

TEST REPORT

RADIATED EMISSION DATA

Mode: WiFi Operating

Table 10

Polarization	Frequency (MHz)	Reading (dB μ V)	Pre-amp (dB)	Antenna Factor (dB)	Net at 3m (dB μ V/m)	Limit at 3m (dB μ V/m)	Margin (dB)
V	49.885	27.2	16	11.0	22.2	40.0	-17.8
V	70.134	30.5	16	7.0	21.5	40.0	-18.5
V	89.413	31.5	16	9.0	24.5	43.5	-19.0
V	124.939	29.7	16	14.0	27.7	43.5	-15.8
V	135.003	30.1	16	14.0	28.1	43.5	-15.4
V	149.916	27.3	16	14.0	25.3	43.5	-18.2
V	199.993	24.3	16	16.0	24.3	43.5	-19.2
H	311.543	24.1	16	23.0	31.1	46.0	-14.9
V	399.934	21.5	16	25.0	30.5	46.0	-15.5
V	562.530	24.1	16	28.0	36.1	46.0	-9.9
H	624.974	22.1	16	29.0	35.1	46.0	-10.9
H	708.394	23.3	16	30.0	37.3	46.0	-8.7
H	750.104	22.0	16	30.0	36.0	46.0	-10.0
H	875.113	20.2	16	32.0	36.2	46.0	-9.8
V	886.025	15.3	16	32.0	31.3	46.0	-14.7

- Notes:
1. Quasi-Peak detector is used for the emission measurement.
 2. All measurements were made at 3 meters.
 3. Negative value in the margin column shows emission below limit.
 4. Emissions within the restricted band meets the requirement of FCC Part 15 Section 15.205 / RSS-Gen Section 8.10.
 5. Measurement Uncertainty is ± 5.3 dB at a level of confidence of 95%.

TEST REPORT

3.7 Transmitter Duty Cycle Calculation

Not Applicable – No average factor is required

3.8 AC Power Line Conducted Emission

- Not Applicable – EUT is only powered by battery for operation.
- EUT connects to AC power line. Emission Data is listed in following pages.
- Base Unit connects to AC power line and has transmission. Handset connects to AC power line but has no transmission. Emission Data of Base Unit is listed in following pages.

3.8.1 AC Power Line Conducted Emission Configuration Photograph

Worst Case Line-Conducted Configuration at 0.4605 MHz.

The worst-case line conducted configuration photographs are attached in the Appendix and saved with filename: Setup Photos.pdf.

3.8.2 AC Power Line Conducted Emission Data

The plot(s) and data in the following pages list the significant emission frequencies, the limit and the margin of compliance.

Passed by 13.1 dB margin

3.8.3 Conducted Emission Test Setup

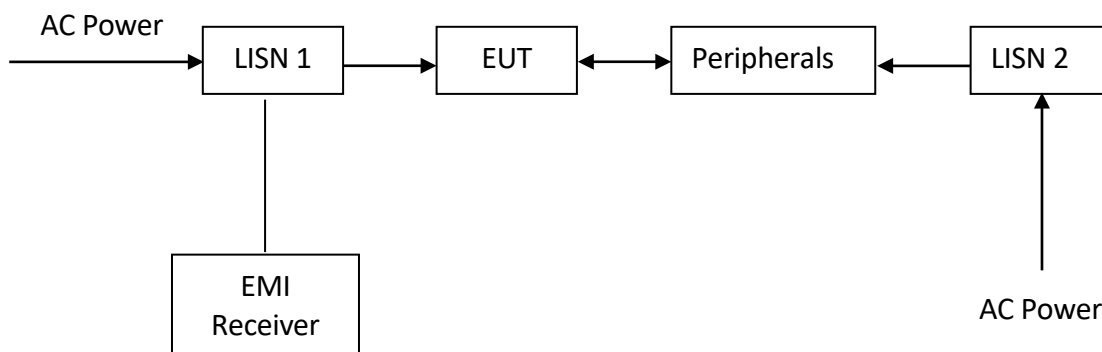

The EUT along with its peripherals were placed on a 1.0m(W)×1.5m(L) and 0.8m in height wooden table and the EUT was adjusted to maintain a 0.4 meter space from a vertical reference plane. The EUT was connected to power mains through a line impedance stabilization network (LISN), which provided 50 ohm coupling impedance for measuring instrument and the chassis ground was bounded to the horizontal ground plane of shielded room. The excess power cable between the EUT and the LISN was bundled.

All connecting cables of EUT and peripherals were moved to find the maximum emission.

TEST REPORT

AC POWER LINE CONDUCTED EMISSION

Worst Case: WiFi Operating



RBW 9 kHz

MT 1 s

Att 10 dB AUTOC PREAMP OFF

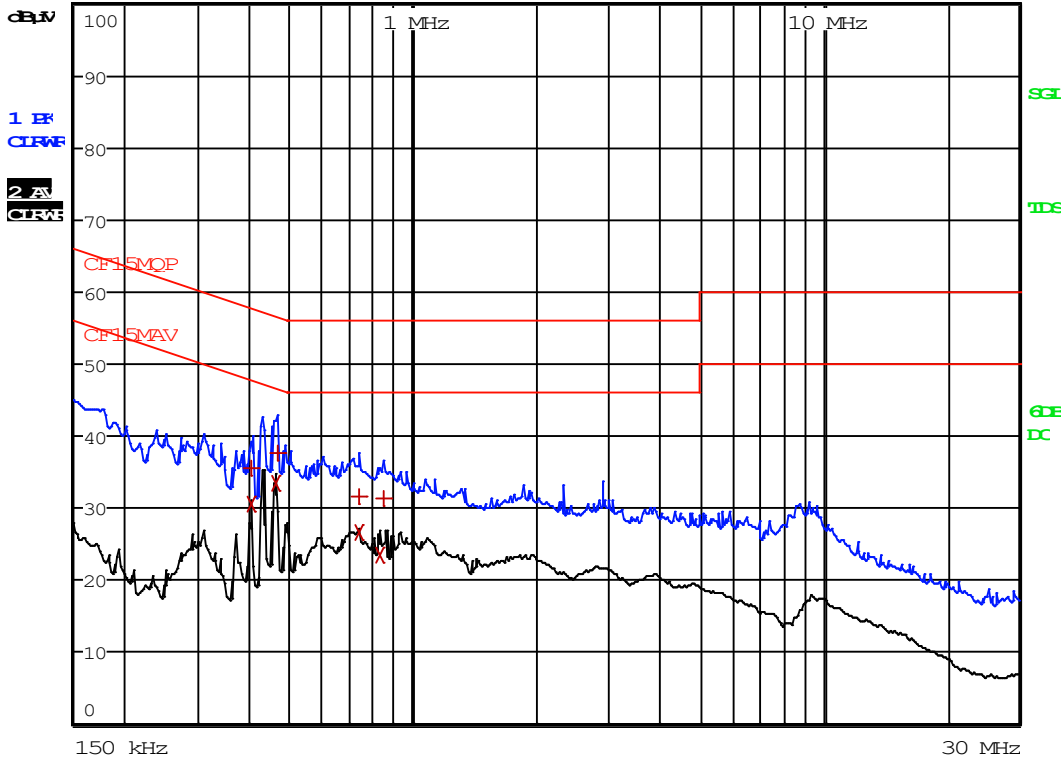

TEST REPORT

AC POWER LINE CONDUCTED EMISSION

Worst Case: WiFi Operating

EDIT PEAK LIST (Final Measurement Results)

Trace1: CF15MQP

Trace2: CF15MAV

Trace3: ---

	TRACE	FREQUENCY	LEVEL dB μ V	DELTA LIMIT dB
1	Quasi Peak	402 kHz	35.65 L1	-22.16
2	CISPR Average	402 kHz	30.61 L1	-17.19
2	CISPR Average	460.5 kHz	33.54 N	-13.14
1	Quasi Peak	465 kHz	37.61 N	-18.98
1	Quasi Peak	735 kHz	31.69 N	-24.31
2	CISPR Average	735 kHz	26.62 L1	-19.37
2	CISPR Average	829.5 kHz	23.42 L1	-22.57
1	Quasi Peak	847.5 kHz	31.48 N	-24.51

TEST REPORT

Occupied Bandwidth Results: (IEEE 802.11b)

Frequency (MHz)	Occupied Bandwidth (MHz)
Low Channel: 2412	13.20
Middle Channel: 2437	13.20
High Channel: 2462	13.10

The worst case is shown as below:

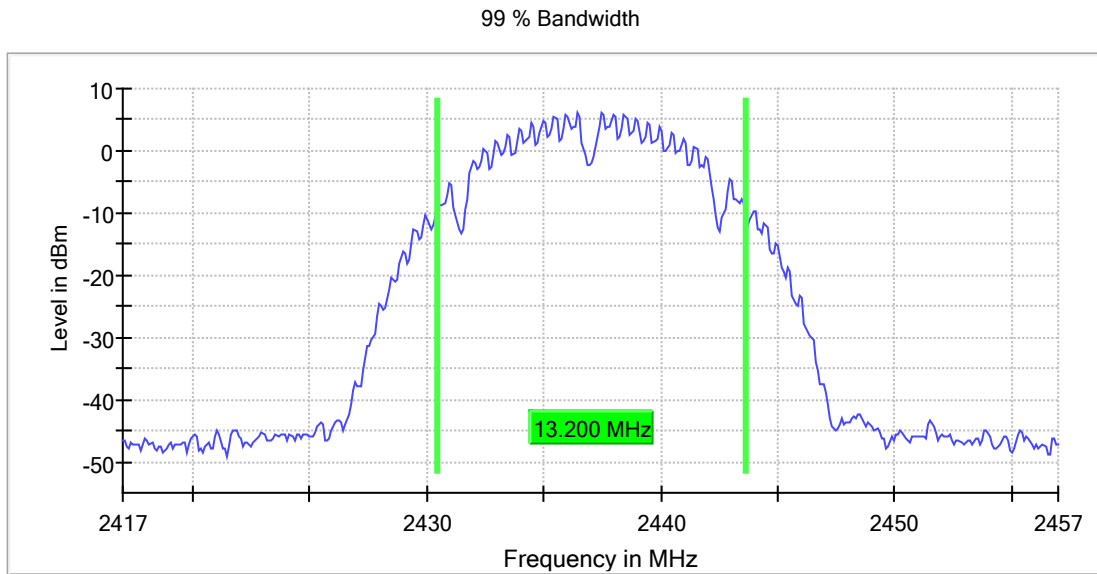

TEST REPORT

Occupied Bandwidth Results: (IEEE 802.11g)

Frequency (MHz)	Occupied Bandwidth (MHz)
Low Channel: 2412	16.60
Middle Channel: 2437	16.50
High Channel: 2462	16.60

The worst case is shown as below:

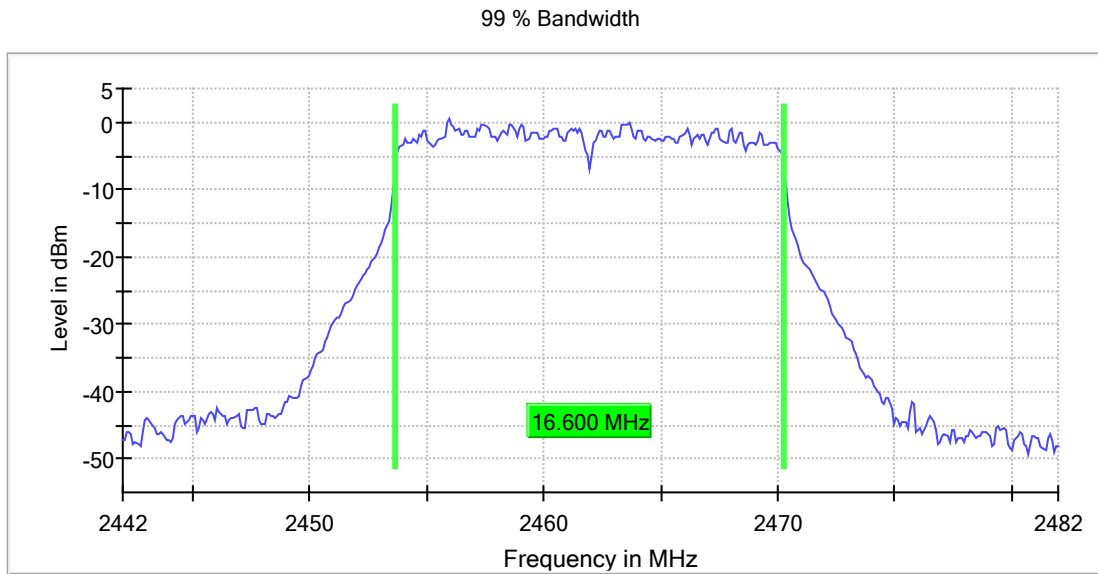

TEST REPORT

Occupied Bandwidth Results: (IEEE 802.11n (20MHz))

Frequency (MHz)	Occupied Bandwidth (MHz)	
Low Channel:	2412	17.65
Middle Channel:	2437	17.65
High Channel:	2462	17.65

The worst case is shown as below:

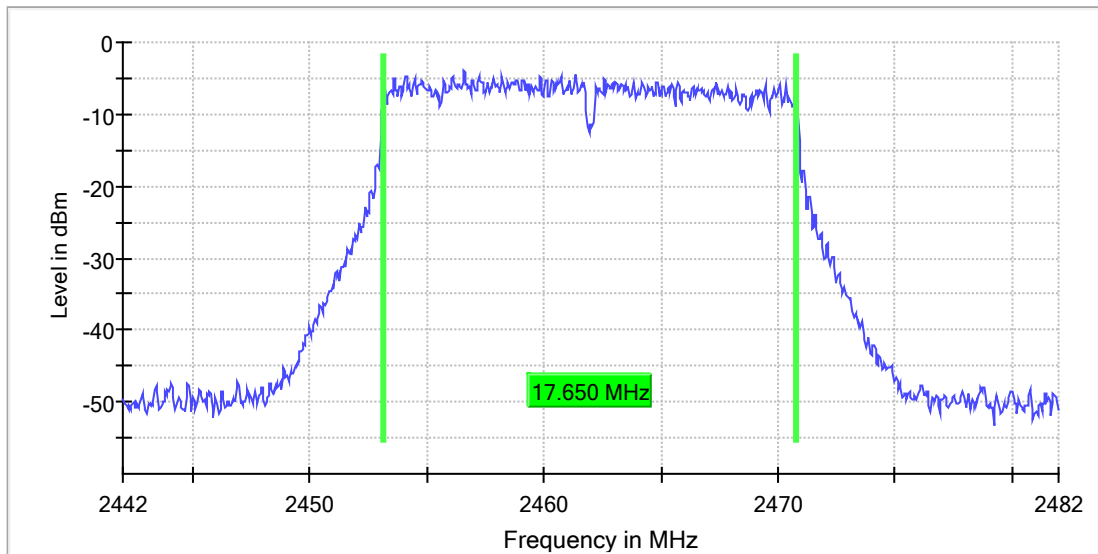

TEST REPORT

EXHIBIT 4 EQUIPMENT LIST

1) Radiated Emissions Test

Equipment	Signal and Spectrum Analyzer (10Hz to 40GHz)	Biconical Antenna (30MHz to 300MHz)	EMI Test Receiver 7GHz
Registration No.	EW-3016	EW-3242	EW-3603
Manufacturer	ROHDESCHWARZ	EMCO	ROHDESCHWARZ
Model No.	FSV40	3110C	ESR7
Calibration Date	December 13, 2022	May 26, 2021	December 06, 2022
Calibration Due Date	December 13, 2023	August 26, 2023	December 06, 2023

Equipment	Log Periodic Antenna	Double Ridged Guide Antenna (1GHz - 18GHz)	Active Loop H-field (9kHz to 30MHz)
Registration No.	EW-3243	EW-0194	EW-3302
Manufacturer	EMCO	EMCO	EMCO
Model No.	3148B	3115	6502
Calibration Date	June 03, 2021	May 10, 2023	September 08, 2022
Calibration Due Date	September 30, 2023	November 10, 2024	September 08, 2023

Equipment	RF Preamplifier (9kHz to 6000MHz)	2.4GHz Notch Filter	14m Double Shield RF Cable (9kHz - 6GHz)
Registration No.	EW-3006b	EW-3435	EW-2376
Manufacturer	SCHWARZBECK	MICROWAVE	RADIALL
Model No.	BBV9718	N0324413	n m/br56/bnc m 14m
Calibration Date	February 15, 2022	June 16, 2022	January 26, 2022
Calibration Due Date	November 15, 2023	September 16, 2023	October 26, 2023

Equipment	RF Cable 14m (1GHz to 26.5GHz)	14m Double Shield RF Cable (20MHz to 6GHz)	Pyramidal Horn Antenna
Registration No.	EW-2781	EW-2074	EW-0905
Manufacturer	GREATBILLION	RADIALL	EMCO
Model No.	SMA m/SHF5MPU /SMA m ra14m,26G	N(m)-RG142-BNC(m) L=14M	3160-09
Calibration Date	December 12, 2022	December 10, 2021	July 20, 2021
Calibration Due Date	December 12, 2023	September 10, 2023	November 20, 2023

TEST REPORT

EXHIBIT 4 EQUIPMENT LIST (CONT'D)

2) Conducted Emissions Test

Equipment	RF Cable 240cm (RG142) (9kHz to 30MHz)	Artificial Mains Network	EMI Test Receiver 7GHz
Registration No.	EW-2454	EW-2501	EW-3481
Manufacturer	RADIALL	ROHDESCHWARZ	ROHDESCHWARZ
Model No.	Bnc m st / 142 / bnc mra 240cm	ENV-216	ESR7
Calibration Date	June 13, 2023	September 11, 2021	December 21, 2021
Calibration Due Date	June 13, 2024	September 11, 2023	September 21, 2023

3) Conductive Measurement Test

Equipment	5m RF Cable (40GHz)	RF Power Meter with Power Sensor (N1921A)	EMI Test Receiver 7GHz
Registration No.	EW-2701	EW-3309	EW-3481
Manufacturer	RADIALL	ROHDESCHWARZ	ROHDESCHWARZ
Model No.	Sma m-m 5m 40G	NRP-Z81	ESR7
Calibration Date	November 24, 2020	February 14, 2023	December 21, 2021
Calibration Due Date	November 24, 2023	February 14, 2024	September 21, 2023

4) Bandedge & Bandwidth Measurement

Equipment	EMI Test Receiver 7GHz	5m RF Cable (40GHz)
Registration No.	EW-3481	EW-2701
Manufacturer	ROHDESCHWARZ	RADIALL
Model No.	ESR7	Sma m-m 5m 40G
Calibration Date	December 21, 2021	November 24, 2020
Calibration Due Date	September 21, 2023	November 24, 2023

5) Control Software for Radiated Emission

Software Information	
Software Name	EMC32
Manufacturer	ROHDESCHWARZ
Software version	10.50.40

END OF TEST REPORT