

TEST REPORT

Report No.: 20120648HKG-002

Application For Class II Permissive Change of 47 CFR Part 15 Certification
Class II Permissive Change of RSS-210 Issue 10 Equipment Certification

DECT 6.0 Cordless Telephone with Bluetooth - Base Unit

FCC ID: EW780-2017-00

IC: 1135B-80201700

Prepared and Checked by:

Approved by:

Signed On File
Leung Chiu Kuen, Stanley
Engineer

Tang Kwan Mo, Jess
Lead Engineer
Date: April 13, 2021

TEST REPORT

GENERAL INFORMATION

Grantee:	VTech Telecommunications Ltd.
Grantee Address:	23/F., Tai Ping Industrial Centre, Block 1, 57 Ting Kok Road, Tai Po, Hong Kong.
FCC Specification Standard:	FCC Part 15, October 1, 2019 Edition
FCC ID:	EW780-2017-00
FCC Model(s):	DLP73210, DLP73410, DLP73440, DLP73540, DLP73**0, IS7256-3, IS725*-**, BL103, BL103-2, BL103-3, B103-4, BL103-5, BL103-**, VS113, VS113-2, VS113-3, VS113-4, VS113-5, VS113-**
IC Specification Standard:	RSS-210 Issue 10, December 2019 RSS-Gen Issue 5, April 2018
IC:	1135B-80201700
HVIN	35-201292BS
VTech Model(s):	1. DLP73210, DLP73410, DLP73440, DLP73540 2. IS7256-3 3. BL103-1K, BL103-2K, BL103-3K, BL103-4K, BL103-5K 4. VS113-1S, VS113-2S, VS113-3S, VS113-4S, VS113-5S
PMN:	1. DLP73210/DLP73410/DLP73440/DLP73540 2. IS7256-3 3. BL103-1K/BL103-2K/BL103-3K/BL103-4K/BL103-5K 4. VS113-1S/VS113-2S/VS113-3S/VS113-4S/VS113-5S
Type of EUT:	Transceiver
Description of EUT:	DECT 6.0 Cordless Telephone with Bluetooth - Base Unit
Serial Number:	N/A
Sample Receipt Date:	December 14, 2020
Date of Test:	December 20, 2020 - March 26, 2021
Report Date:	April 13, 2021
Environmental Conditions:	Temperature: +10 to 40°C Humidity: 10 to 90%
Conclusion:	Test was conducted by client submitted sample. The submitted sample as received complied with the 47 CFR Part 15 / RSS-210 Issue 10 Certification.

TEST REPORT

TABLE OF CONTENTS

1.0 TEST RESULTS SUMMARY & STATEMENT OF COMPLIANCE 4

 1.1 Summary of Test Results.....4

 1.2 Statement of Compliance.....4

2.0 GENERAL DESCRIPTION 5

 2.1 Product Description.....5

 2.2 Test Methodology5

 2.3 Purpose of Change5

 2.4 Test Facility5

3.0 SYSTEM TEST CONFIGURATION..... 6

 3.1 Justification6

 3.2 EUT Exercising Software.....7

 3.3 Radiated Emission Test Setup8

 3.4 Conducted Emission Test Setup9

 3.5 Details of EUT and Description of Accessories.....10

 3.6 Measurement Uncertainty10

4.0 TEST RESULTS..... 11

 4.1 Field Strength Calculation.....11

 4.2 Radiated Emissions.....12

 4.2.1 Radiated Emission Configuration Photograph12

 4.2.2 Radiated Emission Data12

 4.2.3 Transmitter Duty Cycle Calculation18

 4.3 Radiated Emission on the Bandedge19

 4.4 AC Power Line Conducted Emission22

 4.4.1 AC Power Line Conducted Emission Configuration Photograph22

 4.4.2 AC Power Line Conducted Emission Data22

5.0 EQUIPMENT LIST 27

TEST REPORT

1.0 TEST RESULTS SUMMARY & STATEMENT OF COMPLIANCE

1.1 Summary of Test Results

Test Items	FCC Part 15 Section	RSS-210/ RSS-Gen#/ RSS-310^ Section	Results	Details See Section
Radiated Emission	15.249(a), 209, & 109	B10(a)	Pass	4.2
Radiated Emission on the Bandedge	15.249(d)	B10(b)	Pass	4.3
Radiated Emission in Restricted Bands	15.205	7.1	Pass	4.2
AC Power Line Conducted Emission	15.207 & 15.107	8.8 [#]	Pass	4.4

Note: Pursuant to FCC Part 15 Section 15.215(c), the 20dB bandwidth of the emission was contained within the frequency band designated (mentioned as above) which the EUT operated. The effects, if any, from frequency sweeping, frequency hopping, other modulation techniques and frequency stability over expected variations in temperature and supply voltage were considered.

1.2 Statement of Compliance

The equipment under test is found to be complying with the following standards:

FCC Part 15, October 1, 2019 Edition
RSS-210 Issue 10, December 2019
RSS-Gen Issue 5, April 2018

TEST REPORT

2.0 GENERAL DESCRIPTION

2.1 Product Description

The DLP73540 (35-201292BS) is a DECT 6.0 Cordless Telephone with Bluetooth - Base Unit. It operates at frequency range of 2402MHz to 2480MHz. The Base Unit is powered by an AC adaptor 100-240VAC 50/60Hz 0.15A.

The Bluetooth antenna used in base unit is integral, and the test sample is a prototype.

For FCC, the Model(s): DLP73210, DLP73410, DLP73440, DLP73**0, IS7256-3, IS725*-** , BL103, BL103-2, BL103-3, B103-4, BL103-5, BL103-**, VS113, VS113-2, VS113-3, VS113-4, VS113-5 and VS113-** are the same as the Model: DLP73540 in electrical designs including software & firmware, PCB layout and construction design/physical design/enclosure as declared by client. The only differences between these models are model number, color, trade name, package type and number of handsets and chargers to be sold for marketing purpose as declared by client. Suffix ("*" in DLP73**0) indicates different number of handset and extra charger, and different package type or color of enclosure as declared by client. Suffix ("**" in IS725*-**) indicates different package type (material), different number of handset and extra charger, and different color of enclosure as declared by client. Suffix ("**" in BL103-** and VS113-**) indicates different number of handset and extra charger, and different package type (material) or color of enclosure as declared by client.

The circuit description is saved with filename: descri.pdf.

Connection between the device and the telephone network is accomplished through the use of USOC RJ11C in the 2-wire loop calling central office line.

2.2 Test Methodology

Both AC power line-conducted and radiated emission measurements were performed according to the procedures in ANSI C63.4 (2014) and ANSI C63.10 (2013). Preliminary radiated scans and all radiated measurements were performed in Radiated Emission Test Sites. All Radiated tests were performed at an antenna to EUT distance of 3 meters, unless stated otherwise in the "**Justification Section**" of this Application.

2.3 Purpose of Change

The purpose of change is saved with filename: product change.pdf

2.4 Test Facility

The radiated emission test sites and conducted measurement facility used to collect the radiated data and conducted data are at Workshop No. 3, G/F., World-Wide Industrial Centre, 43-47 Shan Mei Street, Fo Tan, Sha Tin, N.T., Hong Kong SAR, China. This test facility and site measurement data have been fully placed on file with the FCC and IC No. 2042H.

TEST REPORT

3.0 SYSTEM TEST CONFIGURATION

3.1 Justification

For radiated emissions testing, the equipment under test (EUT) was setup to transmit continuously mode to simplify the measurement methodology. Care was taken to ensure proper power supply voltages during testing. During testing, all cables (if any) were manipulated to produce worst case emissions.

The Base Unit was powered by a 100-240VAC 50/60Hz 0.15A to 5.9VDC 0.6A or 100-240VAC 60Hz 0.15A to 6.0VDC 600mA 0.36W adaptor.

For the measurements, the EUT was attached to a plastic stand if necessary and placed on the wooden turntable which is four feet in diameter and approximately 0.8m in height above the ground plane for emission measurement at or below 1GHz and 1.5m in height above the ground plane for emission measurement above 1GHz. If the base unit attached to peripherals, they were connected and operational to simulate typical use. The handset was remotely located as far from the antenna and the base as possible to ensure full power transmission from the base. Else, the base was wired to transmit full power.

The signal was maximized through rotation and placement in the three orthogonal axes. The antenna height and polarization were varied during the search for maximum signal level. The antenna height was varied from 1 to 4 meters. Radiated emissions were taken at three meters unless the signal level was too low for measurement at that distance. If necessary, a pre-amplifier was used and/or the test was conducted at a closer distance.

For any intentional radiator powered by AC power line, measurements of the radiated signal level of the fundamental frequency component of the emission was performed with the supply voltage varied between 85% and 115% of the nominal rated supply voltage.

For transmitter radiated measurement, the spectrum analyzer resolution bandwidth was 100 kHz for frequencies below 1000 MHz. The resolution bandwidth was 1 MHz for frequencies above 1000 MHz.

Radiated emission measurement for transmitter was performed from the lowest radio frequency signal generated in the device which is greater than 9 kHz to the tenth harmonic of the highest fundamental frequency or to 40 GHz, whichever is lower.

Emission that are directly caused by digital circuits in the transmit path and transmitter portion were measured, and the limit are according to FCC Part 15 Section 15.209. Digital circuitry used to control additional functions other than the operation of the transmitter are subject to FCC Part 15 Section 15.109 Limits.

The DECT module was put into transmission mode when taking radiated emission data for determining worst-case spurious emission.

TEST REPORT

3.1 Justification - Cont'd

Detector function for radiated emissions is in peak mode. Average readings, when required, are taken by measuring the duty cycle of the equipment under test and subtracting the corresponding amount in dB from the measured peak readings. A detailed description for the calculation of the average factor can be found in section 4.2.3.

Determination of pulse desensitization was made according to *Hewlett Packard Application Note 150-2, Spectrum Analysis... Pulsed RF*. The effective period (Teff) was 625 μ s. With the resolution bandwidth 1MHz and spectrum analyzer IF bandwidth 3dB, the pulse desensitization factor was 0dB.

For AC line conducted emission test, the EUT along with its peripherals were placed on a 1.0m(W)x1.5m(L) and 0.8m in height wooden table and the EUT was adjusted to maintain a 0.4 meter space from a vertical reference plane. The EUT was connected to power mains through a line impedance stabilization network (LISN), which provided 50ohm coupling impedance for measuring instrument. The LISN housing, measuring instrument case, reference ground plane, and vertical ground plane were bounded together. The excess power cable between the EUT and the LISN was bundled.

All connecting cables of EUT and peripherals were manipulated to find the maximum emission.

All relevant operation modes and different type of adaptors have been tested, and the worst case data is included in this report.

3.2 EUT Exercising Software

The EUT exercise program used during radiated and conducted testing was designed to exercise the various system components in a manner similar to a typical use.

TEST REPORT

3.3 Radiated Emission Test Setup

The figure below shows the test setup, which is utilized to make these measurements.

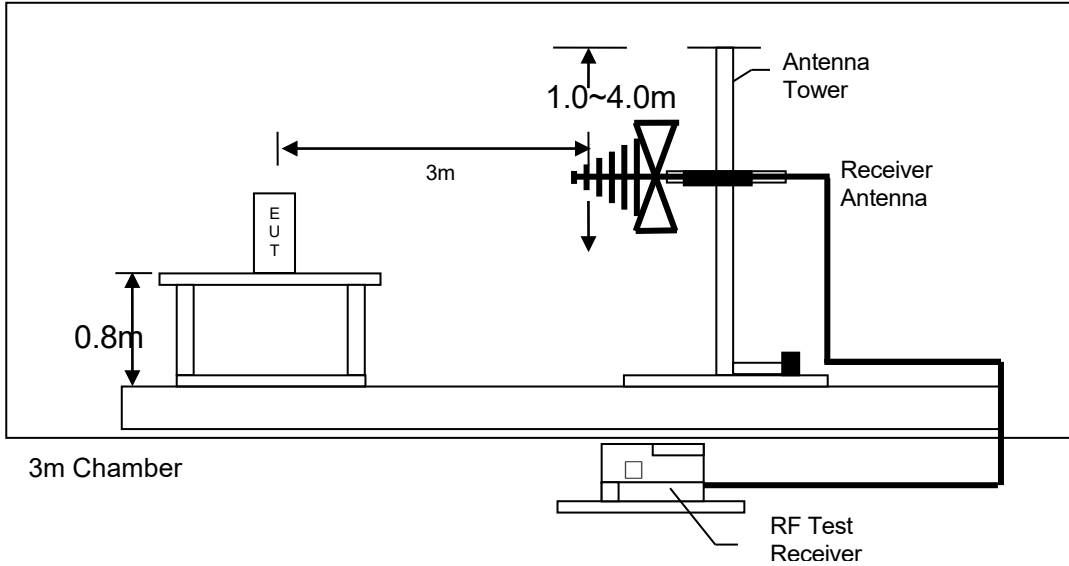

Figure 3.3.1 Test setup of radiated emissions up to 1GHz

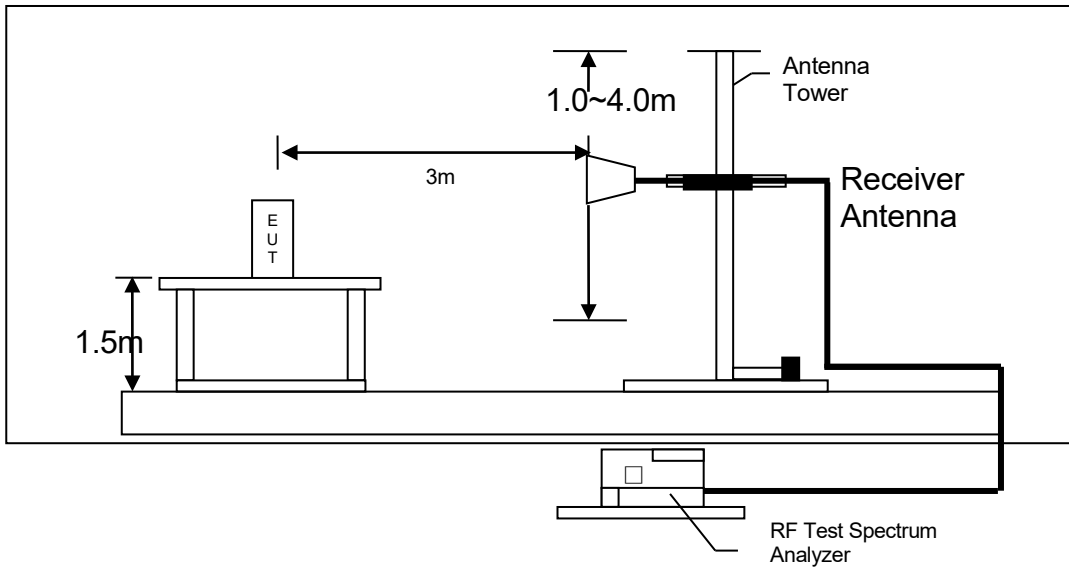

Figure 3.3.2 Test setup of radiated emissions above 1GHz

TEST REPORT

3.4 Conducted Emission Test Setup

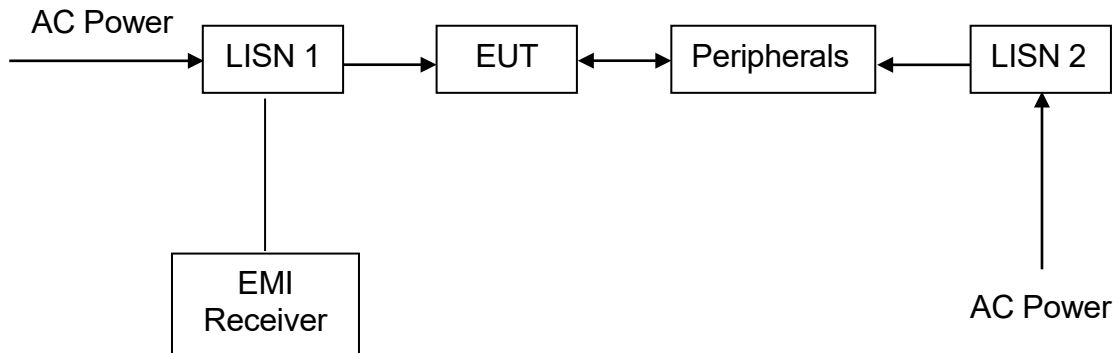

Figure 3.4.1

TEST REPORT

3.5 Details of EUT and Description of Accessories

Details of EUT:

An AC adaptor (provided with the unit) was used to power the device. Their description are listed below.

- (1) An AC adaptor (100-240VAC 60Hz 0.15A to 5.9VDC 0.6A, Model: A318-059060W-US1, Brand: AoHai) (Supplied by Client)
- (2) An AC adaptor (100-240VAC 60Hz 0.15A to 6.0VDC 600mA 0.36W, Model: VT05EUS06060, Brand: VTPL) (Supplied by Client)

Description of Accessories:

- (1) Telecommunication cable with RJ11C connectors (1m, unshielded), terminated (Supplied by Intertek)
- (2) Handset (Model: DL73540, FCC ID: EW780-2017-00) (Supplied by Client)

3.6 Measurement Uncertainty

Decision Rule for compliance: For FCC/IC standard, the measured value must be within the limits of applicable standard without accounting for the measurement uncertainty. For EN/IEC/HKTA/HKTC standard, conformity rules will be used as per standard directly excepted EN/IEC 61000-3-2, EN/IEC 61000-3-3, HKTA1004, HKCA1008, HKTA1019, HKTA1020, HKTA1041 and HKTA1044. For these excepted or not mentioned standards, Cl 4.2.2 of ILAC-G8:09/2019 decision rules will be reference and guard band will be equal to our measurement uncertainty with 95% confidence level (k=2). In case, the measured value is within guard band region, undetermined decision will be used. The values of the Measurement uncertainty for radiated emission test, AC line conducted emission test and RF conducted test, frequency stability and timing jitter are $\pm 5.3\text{dB}$, $\pm 4.2\text{dB}$, $\pm 1\text{dB}$, $\pm 23\text{Hz}$, $0.1\mu\text{s}$ respectively.

Uncertainty and Compliance - Unless the standard specifically states that measured values are to be extended by the measurement uncertainty in determining compliance, all compliance determinations are based on the actual measured value.

TEST REPORT

4.0 TEST RESULTS

Data is included of the worst case configuration (the configuration which resulted in the highest emission levels). A sample calculation, configuration photographs and data tables of the emissions are included.

4.1 Field Strength Calculation

The field strength is calculated by adding the reading on the Spectrum Analyzer to the factors associated with preamplifiers (if any), antennas, cables, pulse desensitization and average factors (when specified limit is in average and measurements are made with peak detectors). A sample calculation is included below.

$$FS = RA + AF + CF - AG + PD + AV$$

where

- FS = Field Strength in dB μ V/m
- RA = Receiver Amplitude (including preamplifier) in dB μ V
- CF = Cable Attenuation Factor in dB
- AF = Antenna Factor in dB
- AG = Amplifier Gain in dB
- PD = Pulse Desensitization in dB
- AV = Average Factor in -dB

In the radiated emission table which follows, the reading shown on the data table may reflect the preamplifier gain. An example of the calculations, where the reading does not reflect the preamplifier gain, follows:

$$FS = RA + AF + CF - AG + PD + AV$$

Example

Assume a receiver reading of 62.0 dB μ V is obtained. The antenna factor of 7.4 dB and cable factor of 1.6 dB is added. The amplifier gain of 29 dB is subtracted. The pulse desensitization factor of the spectrum analyzer was 0 dB, and the resultant average factor was -10 dB. The net field strength for comparison to the appropriate emission limit is 32 dB μ V/m. This value in dB μ V/m was converted to its corresponding level in μ V/m.

$$RA = 62.0 \text{ dB}\mu\text{V}$$

$$AF = 7.4 \text{ dB}$$

$$CF = 1.6 \text{ dB}$$

$$AG = 29 \text{ dB}$$

$$PD = 0 \text{ dB}$$

$$AV = -10 \text{ dB}$$

$$FS = 62 + 7.4 + 1.6 - 29 + 0 + (-10) = 32 \text{ dB}\mu\text{V/m}$$

$$\text{Level in } \mu\text{V/m} = \text{Common Antilogarithm } [(32 \text{ dB}\mu\text{V/m})/20] = 39.8 \mu\text{V/m}$$

TEST REPORT

4.2 Radiated Emissions

4.2.1 Radiated Emission Configuration Photograph

Worst Case Radiated Emission
at

207.325 MHz

The worst case radiated emission configuration photographs are saved with filename: config photos.pdf

4.2.2 Radiated Emission Data

The data in tables 1-5 list the significant emission frequencies, the limit and the margin of compliance. Test setup is shown in section 3.3 Figure 3.3.1 and 3.3.2.

Judgement -

Passed by 12.3 dB margin

TEST REPORT

RADIATED EMISSION DATA

Mode: TX-Channel 00 with Ao Hai Adaptor

Table 1, Base Unit

Polarization	Frequency (MHz)	Reading (dBµV)	Pre-Amp Gain (dB)	Antenna Factor (dB)	Net at 3m - Peak (dBµV/m)	Average Factor (dB)	Calculated at 3m (dBµV/m)	Average Limit at 3m (dBµV/m)	Margin (dB)
V	2402.000	93.8	33	29.4	90.2	24	66.2	94.0	-27.8
H	4804.000	42.2	33	34.9	44.1	24	20.1	54.0	-33.9
H	7206.000	40.3	33	37.9	45.2	24	21.2	54.0	-32.8
V	9608.000	40.3	33	40.4	47.7	24	23.7	54.0	-30.4
H	12010.000	42.7	33	40.5	50.2	24	26.2	54.0	-27.8
V	14412.000	48.0	33	40.0	55.0	24	31.0	54.0	-23.0

Polarization	Frequency (MHz)	Reading (dBµV)	Pre-Amp Gain (dB)	Antenna Factor (dB)	Net at 3m - Peak (dBµV/m)	Peak Limit at 3m (dBµV/m)	Margin (dB)
V	2402.000	93.8	33	29.4	90.2	114.0	-23.8
H	4804.000	42.2	33	34.9	44.1	74.0	-29.9
H	7206.000	40.3	33	37.9	45.2	74.0	-28.8
V	9608.000	40.3	33	40.4	47.7	74.0	-26.4
H	12010.000	42.7	33	40.5	50.2	74.0	-23.8
V	14412.000	48.0	33	40.0	55.0	74.0	-19.0

- NOTES:
1. Peak detector is used for the emission measurement.
 2. All measurements were made at 3 meters.
 3. Negative value in the margin column shows emission below limit.
 4. Horn antenna is used for the emission over 1000MHz.
 5. Emission (the row indicated by ***bold italic***) within the restricted band meets the requirement of FCC Part 15 Section 15.205 / RSS-Gen Section 8.9.

TEST REPORT

Mode: TX-Channel 39 with Ao Hai Adaptor

Table 2, Base Unit

Polarization	Frequency (MHz)	Reading (dBµV)	Pre-Amp Gain (dB)	Antenna Factor (dB)	Net at 3m - Peak (dBµV/m)	Average Factor (dB)	Calculated at 3m (dBµV/m)	Average Limit at 3m (dBµV/m)	Margin (dB)
V	2442.000	93.5	33	29.4	89.9	24	65.9	94.0	-28.1
H	4884.000	42.6	33	34.9	44.5	24	20.5	54.0	-33.5
H	7326.000	41.3	33	37.9	46.2	24	22.2	54.0	-31.8
H	9768.000	39.8	33	40.4	47.2	24	23.2	54.0	-30.8
V	12210.000	42.5	33	40.5	50.0	24	26.0	54.0	-28.0
H	14652.000	49.3	33	38.4	54.7	24	30.7	54.0	-23.3

Polarization	Frequency (MHz)	Reading (dBµV)	Pre-Amp Gain (dB)	Antenna Factor (dB)	Net at 3m - Peak (dBµV/m)	Peak Limit at 3m (dBµV/m)	Margin (dB)
V	2442.000	93.5	33	29.4	89.9	114.0	-24.1
H	4884.000	42.6	33	34.9	44.5	74.0	-29.5
H	7326.000	41.3	33	37.9	46.2	74.0	-27.8
H	9768.000	39.8	33	40.4	47.2	74.0	-26.8
V	12210.000	42.5	33	40.5	50.0	74.0	-24.0
H	14652.000	49.3	33	38.4	54.7	74.0	-19.3

- NOTES:
1. Peak detector is used for the emission measurement.
 2. All measurements were made at 3 meters.
 3. Negative value in the margin column shows emission below limit.
 4. Horn antenna is used for the emission over 1000MHz.
 5. Emission (the row indicated by ***bold italic***) within the restricted band meets the requirement of FCC Part 15 Section 15.205 / RSS-Gen Section 8.9.

TEST REPORT

Mode: TX-Channel 78 with Ao Hai Adaptor

Table 3, Base Unit

Polarization	Frequency (MHz)	Reading (dBµV)	Pre-Amp Gain (dB)	Antenna Factor (dB)	Net at 3m - Peak (dBµV/m)	Average Factor (dB)	Calculated at 3m (dBµV/m)	Average Limit at 3m (dBµV/m)	Margin (dB)
V	2480.000	91.2	33	29.4	87.6	24	63.6	94.0	-30.4
V	4960.000	44.9	33	34.9	46.8	24	22.8	54.0	-31.2
H	7440.000	41.0	33	37.9	45.9	24	21.9	54.0	-32.2
V	9920.000	40.4	33	40.4	47.8	24	23.8	54.0	-30.2
H	12400.000	42.5	33	40.5	50.0	24	26.0	54.0	-28.0
V	14880.000	48.0	33	38.4	53.4	24	29.4	54.0	-24.6

Polarization	Frequency (MHz)	Reading (dBµV)	Pre-Amp Gain (dB)	Antenna Factor (dB)	Net at 3m - Peak (dBµV/m)	Peak Limit at 3m (dBµV/m)	Margin (dB)
V	2480.000	91.2	33	29.4	87.6	114.0	-26.4
V	4960.000	44.9	33	34.9	46.8	74.0	-27.2
H	7440.000	41.0	33	37.9	45.9	74.0	-28.2
V	9920.000	40.4	33	40.4	47.8	74.0	-26.2
H	12400.000	42.5	33	40.5	50.0	74.0	-24.0
V	14880.000	48.0	33	38.4	53.4	74.0	-20.6

- NOTES:
1. Peak detector is used for the emission measurement.
 2. All measurements were made at 3 meters.
 3. Negative value in the margin column shows emission below limit.
 4. Horn antenna is used for the emission over 1000MHz.
 5. Emission (the row indicated by ***bold italic***) within the restricted band meets the requirement of FCC Part 15 Section 15.205 / RSS-Gen Section 8.9.

TEST REPORT

Mode: Bluetooth Ringing and Charging with VTPL Adaptor

Table 4, Base Unit

Polarization	Frequency (MHz)	Reading (dBµV)	Pre-amp (dB)	Antenna Factor (dB)	Net at 3m (dBµV/m)	Limit at 3m (dBµV/m)	Margin (dB)
V	31.338	26.5	16	10.0	20.5	40.0	-19.5
V	55.225	25.6	16	11.0	20.6	40.0	-19.4
V	60.222	26.6	16	10.0	20.6	40.0	-19.4
V	131.641	30.5	16	14.0	28.5	43.5	-15.0
V	207.325	25.0	16	17.0	26.0	43.5	-17.5
V	961.731	13.4	16	33.0	30.4	54.0	-23.6

- NOTES:
1. Peak detector is used for the emission measurement.
 2. All measurements were made at 3 meters.
 3. Negative value in the margin column shows emission below limit.
 4. Horn antenna is used for the emission over 1000MHz.
 5. Emission (the row indicated by ***bold italic***) within the restricted band meets the requirement of FCC Part 15 Section 15.205 / RSS-Gen Section 8.9.

TEST REPORT

Mode: Bluetooth Ringing and Charging with Ao Hai Adaptor

Table 5, Base Unit

Polarization	Frequency (MHz)	Reading (dBµV)	Pre-amp (dB)	Antenna Factor (dB)	Net at 3m (dBµV/m)	Limit at 3m (dBµV/m)	Margin (dB)
V	48.034	29.1	16	11.0	24.1	40.0	-15.9
V	131.519	28.0	16	14.0	26.0	43.5	-17.5
V	193.553	23.9	16	16.0	23.9	43.5	-19.6
V	207.325	30.2	16	17.0	31.2	43.5	-12.3
V	414.756	18.8	16	25.0	27.8	46.0	-18.2
H	962.477	15.5	16	33.0	32.5	54.0	-21.5

- NOTES:
1. Peak detector is used for the emission measurement.
 2. All measurements were made at 3 meters.
 3. Negative value in the margin column shows emission below limit.
 4. Horn antenna is used for the emission over 1000MHz.
 5. Emission (the row indicated by ***bold italic***) within the restricted band meets the requirement of FCC Part 15 Section 15.205 / RSS-Gen Section 8.9.

TEST REPORT

4.2.3 Transmitter Duty Cycle Calculation

Based on the Bluetooth Specification Version 2.0 / 2.1 + EDR, the transmitter ON time for each timeslot of Bluetooth is 625 μ s. DH5 has the maximum duty cycle, which consists of 5 continuous Tx slots and 1 Rx slot. Therefore one hopset take $(5+1) \times 625\mu\text{s} = 3.75\text{ms}$. For one period for a pseudo-random hopping through at least 20 RF channels in adaptive mode (worst case), it take: $20 \times 3.75\text{ms} = 75\text{ms}$.

The dwell time for DH5 is $5 \times 625\mu\text{s} = 3.125\text{ms}$

For the worst case calculation, there are two transmissions might occur in 100ms.

Therefore,

$$\begin{aligned}\text{Duty Cycle (DC)} &= \text{Maximum On time in } 100\text{ms}/100\text{ms} \\ &= 3.125\text{ms} \times 2 / 100\text{ms} \\ &= 0.0625\end{aligned}$$

$$\begin{aligned}\text{Average Factor (AF) of Bluetooth in dB} &= 20 \log_{10} (0.0625) \\ &= -24.0\text{dB}\end{aligned}$$

TEST REPORT

4.3 Radiated Emission on the Bandedge

From the following plots, they show that the fundamental emissions are confined in the specified band (2400MHz and 2483.5MHz). In case of emissions up to two standard bandwidths away from the bandedge, the delta measurement technique is used for determining bandedge compliance. Standard bandwidth is the bandwidth specified by ANSI C63.4 (2014) for frequency being measured.

Emissions radiated outside of the specified frequency bands, except harmonics, are attenuated by 50 dB below the level of the fundamental or to the general radiated emission limits in FCC Part 15 Section 15.209 / Table 4 of RSS-Gen, whichever is the lesser attenuation, which meet the requirement of FCC Part 15 Section 15.249(d) / RSS-210 B10(b).

The plots of radiated emission on the bandedge are saved as below.

TEST REPORT

BASE UNIT WITH BLUETOOTH PORTION, LOWEST CHANNEL

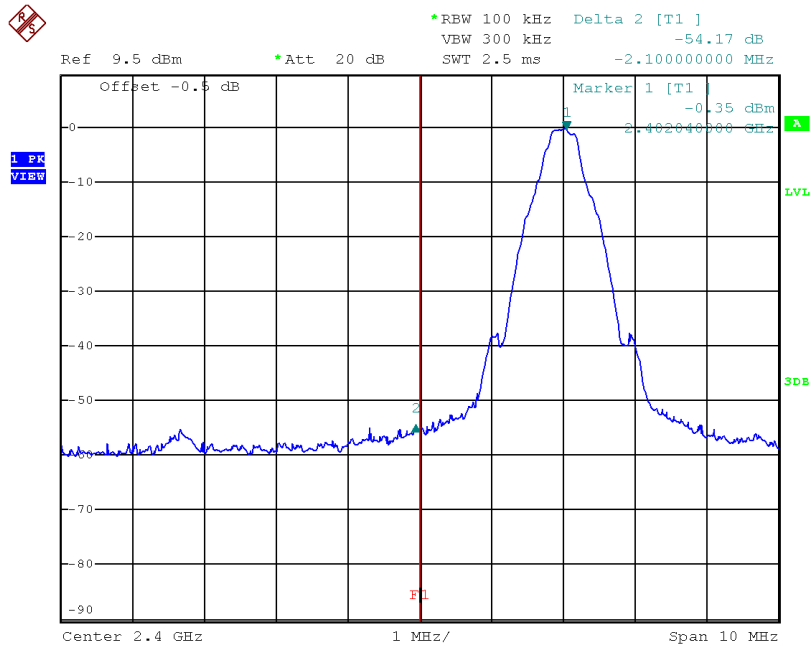

BASE UNIT WITH BLUETOOTH PORTION, HIGHEST CHANNEL

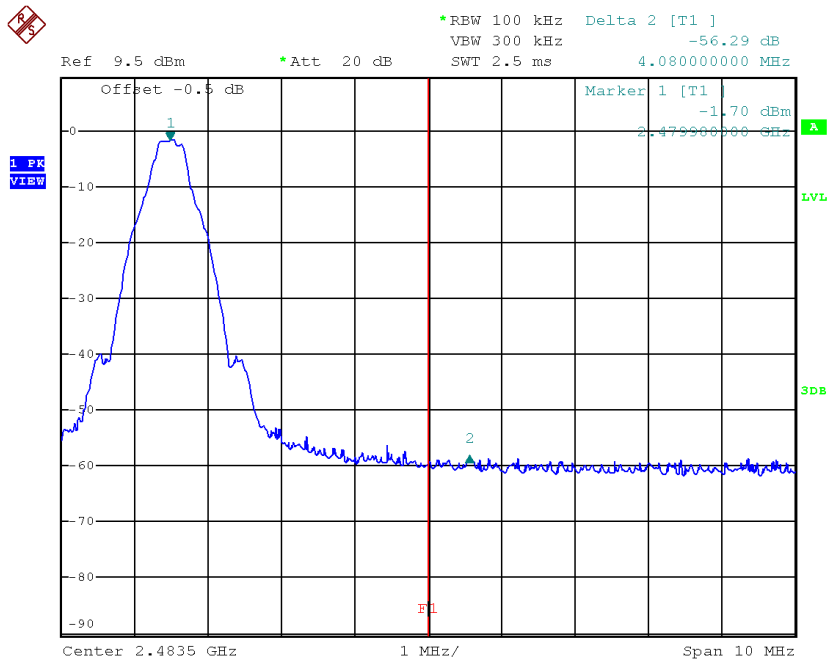

TEST REPORT

Bandedge compliance is determined by applying marker-delta method, i.e.

Resultant Field Strength = Fundamental Emissions - Delta from the plot

Resultant field strength for the lowest and/or highest channel(s), with corresponding average values are calculated as follows:

Channel	Fundamental Emission (dBµV/m)	Delta from the Plot (dB)	Resultant Field Strength (dBµV/m)	Average Limit (dBµV/m)	Margin (dB)
Lowest	66.2	54.17	12.03	54	-41.97
Highest	63.6	56.29	7.31	54	-46.69

Channel	Fundamental Emission (dBµV/m)	Delta from the Plot (dB)	Resultant Field Strength (dBµV/m)	Peak Limit (dBµV/m)	Margin (dB)
Lowest	90.2	54.17	36.03	74	-37.97
Highest	87.6	56.29	31.31	74	-42.69

The resultant field strength meets the general radiated emission limit in Table 4 of RSS-Gen, which does not exceed 74dBµV/m for peak limit and also 54dBµV/m for average limit.

TEST REPORT

4.4 AC Power Line Conducted Emission

- Not applicable – EUT is only powered by battery for operation.
- EUT connects to AC power line. Emission Data is listed in following pages.
- Base Unit connects to AC power line and has transmission. Handset connects to AC power line but has no transmission. Emission Data of Base Unit is listed in following pages.

Test setup is shown in section 3.4 Figure 3.4.1.

4.4.1 AC Power Line Conducted Emission Configuration Photograph

Worst Case Line-Conducted Configuration
at

3.8085 MHz

The worst case line conducted configuration photographs are saved with filename: config photos.pdf.

4.4.2 AC Power Line Conducted Emission Data

The plot(s) and data in the following pages list the significant emission frequencies, the limit and the margin of compliance.

Passed by 18.07 dB margin compared with CISPR average limit

TEST REPORT

CONDUCTED EMISSION DATA

Worst Case: Bluetooth Talk with VTPL Adaptor



RBW 9 kHz
MT 1 s

Att 10 dB AUTIC PREAMP OFF

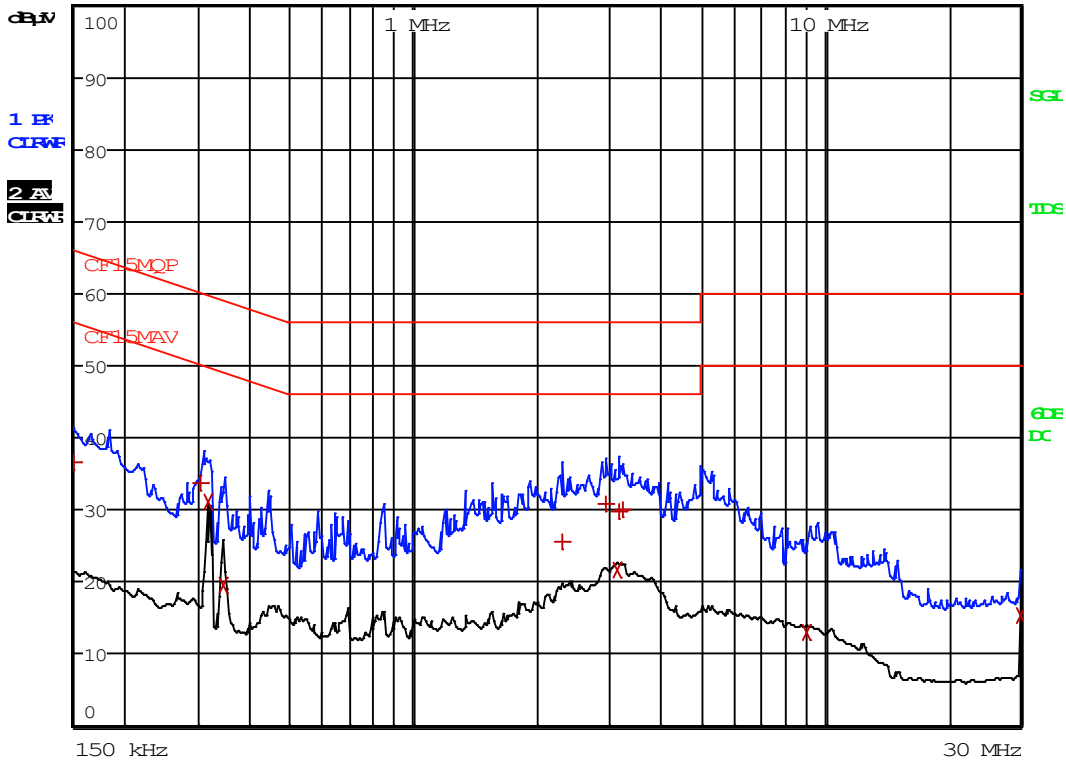

TEST REPORT

Worst Case: Bluetooth Talk with VTPL Adaptor

EDIT PEAK LIST (Final Measurement Results)				
Trace1:	CF15MQP			
Trace2:	CF15MAV			
Trace3:	---			
TRACE	FREQUENCY	LEVEL	dB μ V	DELTA LIMIT
1 Quasi Peak	150 kHz	36.59	N	-29.41
1 Quasi Peak	307.5 kHz	33.82	N	-26.21
2 CISPR Average	316.5 kHz	31.12	L1	-18.67
2 CISPR Average	343.5 kHz	19.52	L1	-29.59
1 Quasi Peak	2.3145 MHz	25.60	N	-30.39
1 Quasi Peak	2.9355 MHz	30.75	L1	-25.24
2 CISPR Average	3.1425 MHz	21.53	N	-24.46
1 Quasi Peak	3.1605 MHz	29.70	N	-26.29
1 Quasi Peak	3.2235 MHz	30.08	L1	-25.91
2 CISPR Average	9.096 MHz	13.03	N	-36.96
2 CISPR Average	29.9985 MHz	15.47	N	-34.52

TEST REPORT

Worst Case: Bluetooth Talk with Ao Hai Adaptor



RES 9 kHz
MT 1 s

Att 10 dB AUTIC PREAMP OFF

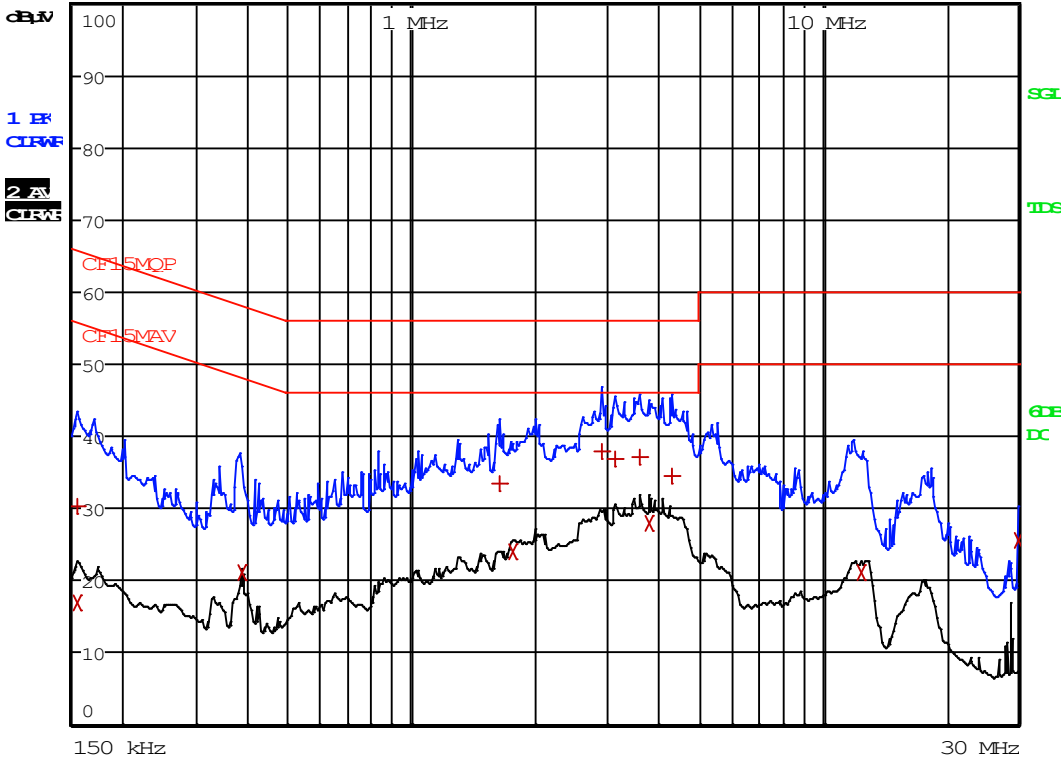

TEST REPORT

Worst Case: Bluetooth Talk with Ao Hai Adaptor

EDIT PEAK LIST (Final Measurement Results)				
Trace1:	CF15MQP			
Trace2:	CF15MAV			
Trace3:	---			
TRACE	FREQUENCY	LEVEL	dB μ V	DELTA LIMIT
1 Quasi Peak	154.5 kHz	30.26	L1	-35.48
2 CISPR Average	154.5 kHz	16.81	N	-38.94
2 CISPR Average	384 kHz	21.01	L1	-27.17
1 Quasi Peak	1.6485 MHz	33.36	L1	-22.63
2 CISPR Average	1.77 MHz	24.05	L1	-21.94
1 Quasi Peak	2.9085 MHz	37.88	N	-18.11
1 Quasi Peak	3.129 MHz	36.81	N	-19.18
1 Quasi Peak	3.6105 MHz	37.21	N	-18.78
2 CISPR Average	3.8085 MHz	27.92	L1	-18.07
1 Quasi Peak	4.308 MHz	34.61	L1	-21.38
2 CISPR Average	12.453 MHz	21.14	N	-28.85
2 CISPR Average	29.9985 MHz	25.47	L1	-24.52

TEST REPORT

5.0 EQUIPMENT LIST

1) Radiated Emissions Test

Equipment	EMI Test Receiver	Spectrum Analyzer	BiConiLog Antenna (30MHz - 6GHz)
Registration No.	EW-3156	EW-2466	EW-3408
Manufacturer	ROHDESCHWARZ	R&S	EMCO
Model No.	ESR26	FSP30	
Calibration Date	September 30, 2020	September 05, 2020	October 25, 2020
Calibration Due Date	September 30, 2021	September 05, 2021	October 25, 2021

Equipment	14m Double Shield RF Cable (20MHz - 6GHz)	High Frequency Coaxial Cable Assembly (4 pcs)	Double Ridged Guide Antenna
Registration No.	EW-2074	EW-2107	EW-0194
Manufacturer	RADIALL	RADIALL	EMCO
Model No.		SMA(m)-SHF5MPU- SMA(m) R.A 14m	3115
Calibration Date	August 29, 2020	July 03, 2020	September 26, 2019
Calibration Due Date	August 29, 2021	July 03, 2021	March 26, 2021

2) Conducted Emissions Test

Equipment	EMI Test Receiver	RF Cable 80cm (RG142) (9kHz to 30MHz)	LISN
Registration No.	EW-3156	EW-2452	EW-2501
Manufacturer	ROHDESCHWARZ	RADIALL	R&S
Model No.	ESR26	bnc m st / 142 / bnc m st 80cm	ENV-216
Calibration Date	September 30, 2020	November 10, 2020	September 11, 2020
Calibration Due Date	September 30, 2021	November 10, 2021	September 11, 2021

3) Conductive Measurement Test

Equipment	Spectrum Analyzer
Registration No.	EW-2466
Manufacturer	R&S
Model No.	FSP30
Calibration Date	September 05, 2020
Calibration Due Date	September 05, 2021

END OF TEST REPORT