

TEST REPORT

Report No.: 19120297HKG-004

Application For Original Grant of 47 CFR Part 15 Certification

New Family of RSS-210 Issue 10 Equipment Certification

FCC ID: EW780-1889-00

IC: 1135B-80188900

Prepared and Checked by:

Approved by:

Signed On File
Leung Chiu Kuen, Stanley
Engineer

Tang Kwan Mo, Jess
Lead Engineer
Date: March 04, 2020

TEST REPORT

GENERAL INFORMATION

Grantee:	VTech Telecommunications Ltd.
Grantee Address:	23/F., Tai Ping Industrial Centre, Block 1, 57 Ting Kok Road, Tai Po, Hong Kong.
FCC Specification Standard:	FCC Part 15, October 1, 2018 Edition
FCC ID:	EW780-1889-00
FCC Model(s):	XLCgo, XLC8-GO CB, XLCgo HS, XLC8-GO HS2
IC Specification Standard:	RSS-210 Issue 10, December 2019 RSS-Gen Issue 5, April 2018
IC:	1135B-80188900
HVIN	XLCgo HS, XLC8-GO HS2
PMN	XLCgo HS, XLC8-GO HS2
Type of EUT:	Transceiver
Description of EUT:	Cell Phone Calls Amplified
Serial Number:	N/A
Sample Receipt Date:	December 06, 2019
Date of Test:	December 06, 2019 to February 11, 2020
Report Date:	March 04, 2020
Environmental Conditions:	Temperature: +10 to 40°C Humidity: 10 to 90%
Conclusion:	Test was conducted by client submitted sample. The submitted sample as received complied with the 47 CFR Part 15 / RSS-210 Issue 10 Certification.

TEST REPORT

TABLE OF CONTENTS

1.0 TEST RESULTS SUMMARY & STATEMENT OF COMPLIANCE 4
 1.1 Summary of Test Results.....4
 1.2 Statement of Compliance.....4

2.0 GENERAL DESCRIPTION 5
 2.1 Product Description.....5
 2.2 Test Methodology5
 2.3 Test Facility5

3.0 SYSTEM TEST CONFIGURATION..... 6
 3.1 Justification6
 3.2 EUT Exercising Software.....7
 3.3 Radiated Emission Test Setup8
 3.4 Conducted Emission Test Setup9
 3.5 Details of EUT and Description of Accessories.....10
 3.6 Measurement Uncertainty.....10

4.0 TEST RESULTS..... 11
 4.1 Field Strength Calculation.....11
 4.2 Radiated Emissions.....12
 4.2.1 Radiated Emission Configuration Photograph.....12
 4.2.2 Radiated Emission Data.....12
 4.2.3 Transmitter Duty Cycle Calculation20
 4.3 Radiated Emission on the Bandedge21
 4.4 AC Power Line Conducted Emission25

5.0 EQUIPMENT LIST 26

TEST REPORT

1.0 TEST RESULTS SUMMARY & STATEMENT OF COMPLIANCE

1.1 Summary of Test Results

Test Items	FCC Part 15 Section	RSS-210/ RSS-Gen#/ RSS-310^ Section	Results	Details See Section
Antenna Requirement	15.203	6.8 [#]	Pass	2.1
Security Code Information	15.214(d)	2.4	Pass	2.1
Radiated Emission	15.249(a), 209, & 109	A2.9(a)	Pass	4.2
Radiated Emission on the Bandedge	15.249(d)	A2.9(b)	Pass	4.3
Radiated Emission in Restricted Bands	15.205	2.2	Pass	4.2
AC Power Line Conducted Emission	15.207 & 15.107	8.8 [#]	NA	4.4

Note: Pursuant to FCC Part 15 Section 15.215(c), the 20dB bandwidth of the emission was contained within the frequency band designated (mentioned as above) which the EUT operated. The effects, if any, from frequency sweeping, frequency hopping, other modulation techniques and frequency stability over expected variations in temperature and supply voltage were considered.

1.2 Statement of Compliance

The equipment under test is found to be complying with the following standards:

FCC Part 15, October 1, 2018 Edition
RSS-210 Issue 10, December 2019
RSS-Gen Issue 5, April 2018

TEST REPORT

2.0 GENERAL DESCRIPTION

2.1 Product Description

The XLCgo (XLCgo HS) is a Cell Phone Calls Amplified. It operates at frequency range of 2402MHz to 2480MHz. The EUT is powered by a Li-Polymer type rechargeable battery (3.7V 950mAh 3.5Wh).

The Bluetooth antenna used in handset is integral, and the test sample is a prototype.

For FCC, the Model(s): XLC8-GO CB, XLCgo HS and XLC8-GO HS2 are the same as the Model: XLCgo in electronics/electrical designs including software & firmware, PCB layout and construction design/physical design/enclosure as declared by client. The only differences between these models are color and model number to be sold for marketing purpose as declared by client.

For IC, the Model(s): XLC8-GO HS2 is the same as the Model: XLCgo HS in electronics/electrical designs including software & firmware, PCB layout and construction design/physical design/enclosure as declared by client. The only differences between these models are color and model number to be sold for marketing purpose as declared by client.

The circuit description is saved with filename: descri.pdf.

2.2 Test Methodology

Radiated emission measurements was performed according to the procedures in ANSI C63.4 (2014) and ANSI C63.10 (2013). Preliminary radiated scans and all radiated measurements were performed in Radiated Emission Test Sites. All Radiated tests were performed at an antenna to EUT distance of 3 meters, unless stated otherwise in the "**Justification Section**" of this Application.

2.3 Test Facility

The radiated emission test sites and conducted measurement facility used to collect the radiated data and conducted data are at Workshop No. 3, G/F., World-Wide Industrial Centre, 43-47 Shan Mei Street, Fo Tan, Sha Tin, N.T., Hong Kong SAR, China. This test facility and site measurement data have been fully placed on file with the FCC and IC No. 2042H.

TEST REPORT

3.0 SYSTEM TEST CONFIGURATION

3.1 Justification

For radiated emissions testing, the equipment under test (EUT) was setup to transmit continuously mode to simplify the measurement methodology. Care was taken to ensure proper power supply voltages during testing. During testing, all cables (if any) were manipulated to produce worst case emissions.

The handset was powered by a fully charged battery.

For the measurements, the EUT was attached to a plastic stand if necessary and placed on the wooden turntable which is four feet in diameter and approximately 0.8m in height above the ground plane for emission measurement at or below 1GHz and 1.5m in height above the ground plane for emission measurement above 1GHz. If the base unit attached to peripherals, they were connected and operational to simulate typical use. The handset was remotely located as far from the antenna and the base as possible to ensure full power transmission from the base. Else, the base was wired to transmit full power.

The signal was maximized through rotation and placement in the three orthogonal axes. The antenna height and polarization were varied during the search for maximum signal level. The antenna height was varied from 1 to 4 meters. Radiated emissions were taken at three meters unless the signal level was too low for measurement at that distance. If necessary, a pre-amplifier was used and/or the test was conducted at a closer distance.

For transmitter radiated measurement, the spectrum analyzer resolution bandwidth was 100 kHz for frequencies below 1000 MHz. The resolution bandwidth was 1 MHz for frequencies above 1000 MHz.

Radiated emission measurement for transmitter was performed from the lowest radio frequency signal generated in the device which is greater than 9 kHz to the tenth harmonic of the highest fundamental frequency or to 40 GHz, whichever is lower.

Emission that are directly caused by digital circuits in the transmit path and transmitter portion were measured, and the limit are according to FCC Part 15 Section 15.209. Digital circuitry used to control additional functions other than the operation of the transmitter are subject to FCC Part 15 Section 15.109 Limits.

The DECT module was put into transmission mode when taking radiated emission data for determining worst-case spurious emission.

TEST REPORT

3.1 Justification - Cont'd

Detector function for radiated emissions is in peak mode. Average readings, when required, are taken by measuring the duty cycle of the equipment under test and subtracting the corresponding amount in dB from the measured peak readings. A detailed description for the calculation of the average factor can be found in section 4.2.3.

Determination of pulse desensitization was made according to *Hewlett Packard Application Note 150-2, Spectrum Analysis... Pulsed RF*. The effective period (Teff) was 625 μ s. With the resolution bandwidth 1MHz and spectrum analyzer IF bandwidth 3dB, the pulse desensitization factor was 0dB.

All connecting cables of EUT and peripherals were manipulated to find the maximum emission.

All relevant operation modes have been tested, and the worst case data was included in this report.

3.2 EUT Exercising Software

The EUT exercise program used during radiated and conducted testing was designed to exercise the various system components in a manner similar to a typical use.

TEST REPORT

3.3 Radiated Emission Test Setup

The figure below shows the test setup, which is utilized to make these measurements.

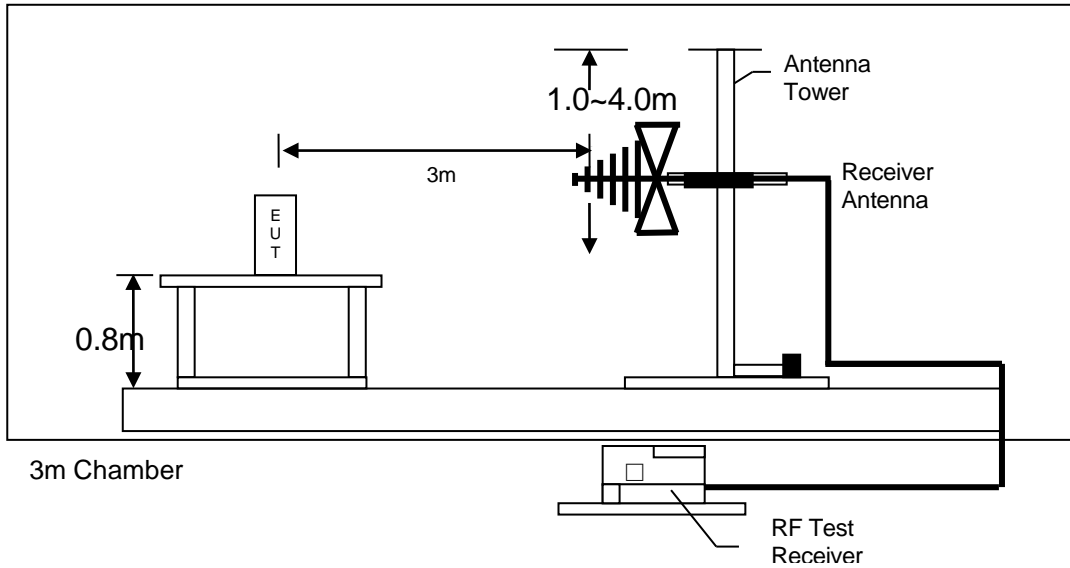

Figure 3.3.1 Test setup of radiated emissions up to 1GHz

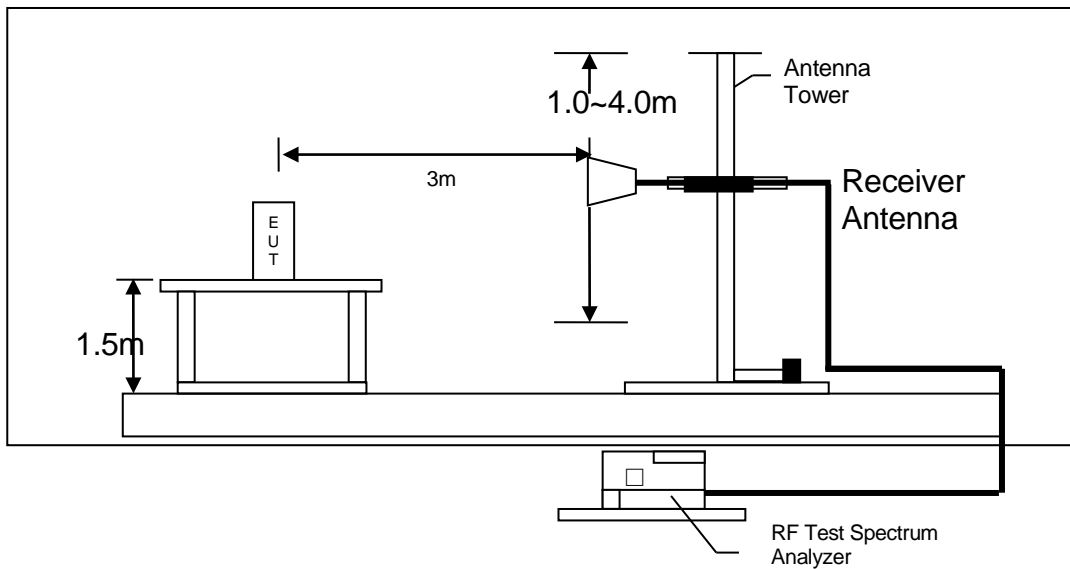

Figure 3.3.2 Test setup of radiated emissions above 1GHz

TEST REPORT

3.4 Conducted Emission Test Setup

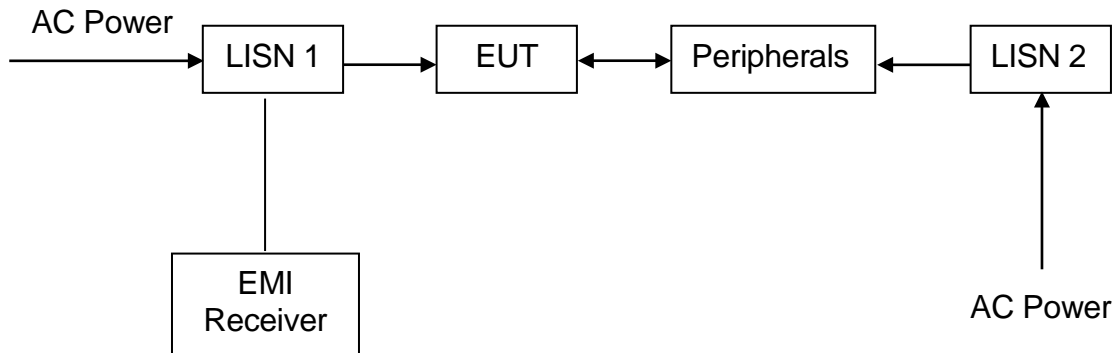

Figure 3.4.1

TEST REPORT

3.5 Details of EUT and Description of Accessories

Details of EUT:

A battery (provided with the unit) were used to power the device. Their descriptions are listed below.

- (1) Li-Polymer type rechargeable battery (3.7V 950mAh 3.5Wh) (Supplied by Client)

Description of Accessories:

- (1) Base Unit (Model: XLC8, FCC ID: EW780-1847-00) (Supplied by Client)

3.6 Measurement Uncertainty

When determining of the test conclusion, the Measurement Uncertainty of test has been considered. The values of the Measurement uncertainty for radiated emission test, AC line conducted emission test and RF conducted test, frequency stability and timing jitter are $\pm 5.3\text{dB}$, $\pm 4.2\text{dB}$, $\pm 1\text{dB}$, $\pm 23\text{Hz}$, $0.1\mu\text{s}$ respectively.

Uncertainty and Compliance - Unless the standard specifically states that measured values are to be extended by the measurement uncertainty in determining compliance, all compliance determinations are based on the actual measured value.

TEST REPORT

4.0 TEST RESULTS

Data is included of the worst case configuration (the configuration which resulted in the highest emission levels). A sample calculation, configuration photographs and data tables of the emissions are included.

4.1 Field Strength Calculation

The field strength is calculated by adding the reading on the Spectrum Analyzer to the factors associated with preamplifiers (if any), antennas, cables, pulse desensitization and average factors (when specified limit is in average and measurements are made with peak detectors). A sample calculation is included below.

$$FS = RA + AF + CF - AG + PD + AV$$

where

- FS = Field Strength in dB μ V/m
- RA = Receiver Amplitude (including preamplifier) in dB μ V
- CF = Cable Attenuation Factor in dB
- AF = Antenna Factor in dB
- AG = Amplifier Gain in dB
- PD = Pulse Desensitization in dB
- AV = Average Factor in -dB

In the radiated emission table which follows, the reading shown on the data table may reflect the preamplifier gain. An example of the calculations, where the reading does not reflect the preamplifier gain, follows:

$$FS = RA + AF + CF - AG + PD + AV$$

Example

Assume a receiver reading of 62.0 dB μ V is obtained. The antenna factor of 7.4 dB and cable factor of 1.6 dB is added. The amplifier gain of 29 dB is subtracted. The pulse desensitization factor of the spectrum analyzer was 0 dB, and the resultant average factor was -10 dB. The net field strength for comparison to the appropriate emission limit is 32 dB μ V/m. This value in dB μ V/m was converted to its corresponding level in μ V/m.

$$RA = 62.0 \text{ dB}\mu\text{V}$$

$$AF = 7.4 \text{ dB}$$

$$CF = 1.6 \text{ dB}$$

$$AG = 29 \text{ dB}$$

$$PD = 0 \text{ dB}$$

$$AV = -10 \text{ dB}$$

$$FS = 62 + 7.4 + 1.6 - 29 + 0 + (-10) = 32 \text{ dB}\mu\text{V/m}$$

$$\text{Level in } \mu\text{V/m} = \text{Common Antilogarithm } [(32 \text{ dB}\mu\text{V/m})/20] = 39.8 \mu\text{V/m}$$

TEST REPORT

4.2 Radiated Emissions

4.2.1 Radiated Emission Configuration Photograph

Worst Case Radiated Emission
at

2440 MHz

The worst case radiated emission configuration photographs are saved with filename: config photos.pdf

4.2.2 Radiated Emission Data

The data in tables 1-7 list the significant emission frequencies, the limit and the margin of compliance. Test setup is shown in section 3.3 Figure 3.3.1 and 3.3.2.

Judgement -

Passed by 11.2 dB margin compared with Average limit

TEST REPORT

RADIATED EMISSION DATA

Mode: TX-Channel 00 (Bluetooth 3.0)

Table 1, Handset

Polarization	Frequency (MHz)	Reading (dBµV)	Pre-Amp Gain (dB)	Antenna Factor (dB)	Net at 3m - Peak (dBµV/m)	Average Factor (dB)	Calculated at 3m (dBµV/m)	Average Limit at 3m (dBµV/m)	Margin (dB)
H	2402.000	99.5	33	29.4	95.9	24	71.9	94.0	-22.1
H	4804.000	52.6	33	34.9	54.5	24	30.5	54.0	-23.5
H	7206.000	39.5	33	37.9	44.4	24	20.4	54.0	-33.6
H	9608.000	35.5	33	40.4	42.9	24	18.9	54.0	-35.1
H	12010.000	34.1	33	40.5	41.6	24	17.6	54.0	-36.5
H	14412.000	9.4	33	40.0	40.4	24	16.4	54.0	-37.6

Polarization	Frequency (MHz)	Reading (dBµV)	Pre-Amp Gain (dB)	Antenna Factor (dB)	Net at 3m - Peak (dBµV/m)	Peak Limit at 3m (dBµV/m)	Margin (dB)
H	2402.000	99.5	33	29.4	95.9	114.0	-18.1
H	4804.000	52.6	33	34.9	54.5	74.0	-19.5
H	7206.000	39.5	33	37.9	44.4	74.0	-29.6
H	9608.000	35.5	33	40.4	42.9	74.0	-31.1
H	12010.000	34.1	33	40.5	41.6	74.0	-32.5
H	14412.000	33.4	33	40.0	40.4	74.0	-33.6

- NOTES:
1. Peak detector is used for the emission measurement.
 2. All measurements were made at 3 meters. Radiated emissions not detected at the 3-meter distance were measured at 0.3-meter and an inverse proportional extrapolation was performed to compare the signal level to the 3-meter limit. No other radiated emissions than those reported were detected at a test distance of 0.3-meter.
 3. Negative value in the margin column shows emission below limit.
 4. Horn antenna is used for the emission over 1000MHz.
 5. Emission (the row indicated by ***bold italic***) within the restricted band meets the requirement of FCC Part 15 Section 15.205 / RSS-210 Section 2.2.

TEST REPORT

Mode: TX-Channel 39 (Bluetooth 3.0)

Table 2, Handset

Polarization	Frequency (MHz)	Reading (dBµV)	Pre-Amp Gain (dB)	Antenna Factor (dB)	Net at 3m - Peak (dBµV/m)	Average Factor (dB)	Calculated at 3m (dBµV/m)	Average Limit at 3m (dBµV/m)	Margin (dB)
H	2440.000	98.0	33	29.4	94.4	24	70.4	94.0	-23.6
H	4880.000	51.3	33	34.9	53.2	24	29.2	54.0	-24.8
H	7320.000	39.4	33	37.9	44.3	24	20.3	54.0	-33.7
H	9760.000	36.4	33	40.4	43.8	24	19.8	54.0	-34.2
H	12200.000	35.9	33	40.5	43.4	24	19.4	54.0	-34.6
H	14640.000	36.8	33	38.4	42.2	24	18.2	54.0	-35.8

Polarization	Frequency (MHz)	Reading (dBµV)	Pre-Amp Gain (dB)	Antenna Factor (dB)	Net at 3m - Peak (dBµV/m)	Peak Limit at 3m (dBµV/m)	Margin (dB)
H	2440.000	98.0	33	29.4	94.4	114.0	-19.6
H	4880.000	51.3	33	34.9	53.2	74.0	-20.8
H	7320.000	39.4	33	37.9	44.3	74.0	-29.7
H	9760.000	36.4	33	40.4	43.8	74.0	-30.2
H	12200.000	35.9	33	40.5	43.4	74.0	-30.6
H	14640.000	36.8	33	38.4	42.2	74.0	-31.8

- NOTES:
1. Peak detector is used for the emission measurement.
 2. All measurements were made at 3 meters. Radiated emissions not detected at the 3-meter distance were measured at 0.3-meter and an inverse proportional extrapolation was performed to compare the signal level to the 3-meter limit. No other radiated emissions than those reported were detected at a test distance of 0.3-meter.
 3. Negative value in the margin column shows emission below limit.
 4. Horn antenna is used for the emission over 1000MHz.
 5. Emission (the row indicated by ***bold italic***) within the restricted band meets the requirement of FCC Part 15 Section 15.205 / RSS-210 Section 2.2.

TEST REPORT

Mode: TX-Channel 78 (Bluetooth 3.0)

Table 3, Handset

Polarization	Frequency (MHz)	Reading (dBµV)	Pre-Amp Gain (dB)	Antenna Factor (dB)	Net at 3m - Peak (dBµV/m)	Average Factor (dB)	Calculated at 3m (dBµV/m)	Average Limit at 3m (dBµV/m)	Margin (dB)
H	2480.000	97.2	33	29.4	93.6	24	69.6	94.0	-24.4
H	4960.000	51.2	33	34.9	53.1	24	29.1	54.0	-24.9
H	7440.000	37.9	33	37.9	42.8	24	18.8	54.0	-35.2
H	9920.000	34.2	33	40.4	41.6	24	17.6	54.0	-36.4
H	12400.000	33.7	33	40.5	41.2	24	17.2	54.0	-36.9
H	14880.000	10.9	33	38.4	40.3	24	16.3	54.0	-37.7

Polarization	Frequency (MHz)	Reading (dBµV)	Pre-Amp Gain (dB)	Antenna Factor (dB)	Net at 3m - Peak (dBµV/m)	Peak Limit at 3m (dBµV/m)	Margin (dB)
H	2480.000	97.2	33	29.4	93.6	114.0	-20.4
H	4960.000	51.2	33	34.9	53.1	74.0	-20.9
H	7440.000	37.9	33	37.9	42.8	74.0	-31.2
H	9920.000	34.2	33	40.4	41.6	74.0	-32.4
H	12400.000	33.7	33	40.5	41.2	74.0	-32.9
H	14880.000	34.9	33	38.4	40.3	74.0	-33.7

- NOTES:
1. Peak detector is used for the emission measurement.
 2. All measurements were made at 3 meters. Radiated emissions not detected at the 3-meter distance were measured at 0.3-meter and an inverse proportional extrapolation was performed to compare the signal level to the 3-meter limit. No other radiated emissions than those reported were detected at a test distance of 0.3-meter.
 3. Negative value in the margin column shows emission below limit.
 4. Horn antenna is used for the emission over 1000MHz.
 5. Emission (the row indicated by ***bold italic***) within the restricted band meets the requirement of FCC Part 15 Section 15.205 / RSS-210 Section 2.2.

TEST REPORT

Mode: TX-Channel 00 (Bluetooth 4.0)

Table 4, Handset

Polarization	Frequency (MHz)	Reading (dBµV)	Pre-Amp Gain (dB)	Antenna Factor (dB)	Net at 3m - Peak (dBµV/m)	Calculated at 3m (dBµV/m)	Average Limit at 3m (dBµV/m)	Margin (dB)
H	2402.000	79.0	33	29.4	75.4	75.4	94.0	-18.6
H	4804.000	40.7	33	34.9	42.6	42.6	54.0	-11.4
H	7206.000	25.3	33	37.9	30.2	30.2	54.0	-23.8
H	9608.000	22.8	33	40.4	30.2	30.2	54.0	-23.8
H	12010.000	21.9	33	40.5	29.4	29.4	54.0	-24.6
H	14412.000	22.3	33	40.0	29.3	29.3	54.0	-24.7

Polarization	Frequency (MHz)	Reading (dBµV)	Pre-Amp Gain (dB)	Antenna Factor (dB)	Net at 3m - Peak (dBµV/m)	Peak Limit at 3m (dBµV/m)	Margin (dB)
H	2402.000	98.7	33	29.4	95.1	114.0	-18.9
H	4804.000	52.4	33	34.9	54.3	74.0	-19.7
H	7206.000	39.0	33	37.9	43.9	74.0	-30.2
H	9608.000	35.7	33	40.4	43.1	74.0	-30.9
H	12010.000	34.8	33	40.5	42.3	74.0	-31.7
H	14412.000	35.0	33	40.0	42.0	74.0	-32.0

- NOTES:
1. Peak detector is used for the emission measurement.
 2. All measurements were made at 3 meters. Radiated emissions not detected at the 3-meter distance were measured at 0.3-meter and an inverse proportional extrapolation was performed to compare the signal level to the 3-meter limit. No other radiated emissions than those reported were detected at a test distance of 0.3-meter.
 3. Negative value in the margin column shows emission below limit.
 4. Horn antenna is used for the emission over 1000MHz.
 5. Emission (the row indicated by ***bold italic***) within the restricted band meets the requirement of FCC Part 15 Section 15.205 / RSS-210 Section 2.2.

TEST REPORT

Mode: TX-Channel 39 (Bluetooth 4.0)

Table 5, Handset

Polarization	Frequency (MHz)	Reading (dBμV)	Pre-Amp Gain (dB)	Antenna Factor (dB)	Net at 3m - Peak (dBμV/m)	Calculated at 3m (dBμV/m)	Average Limit at 3m (dBμV/m)	Margin (dB)
H	2440.000	86.4	33	29.4	82.8	82.8	94.0	-11.2
H	4880.000	31.2	33	34.9	33.1	33.1	54.0	-21.0
H	7320.000	18.6	33	37.9	23.5	23.5	54.0	-30.5
H	9760.000	15.8	33	40.4	23.2	23.2	54.0	-30.8
H	12200.000	15.3	33	40.5	22.8	22.8	54.0	-31.2
H	14640.000	17.2	33	38.4	22.6	22.6	54.0	-31.4

Polarization	Frequency (MHz)	Reading (dBμV)	Pre-Amp Gain (dB)	Antenna Factor (dB)	Net at 3m - Peak (dBμV/m)	Peak Limit at 3m (dBμV/m)	Margin (dB)
H	2440.000	98.7	33	29.4	95.1	114.0	-19.0
H	4880.000	45.3	33	34.9	47.2	74.0	-26.8
H	7320.000	32.4	33	37.9	37.3	74.0	-36.7
H	9760.000	30.2	33	40.4	37.6	74.0	-36.4
H	12200.000	28.9	33	40.5	36.4	74.0	-37.6
H	14640.000	30.2	33	38.4	35.6	74.0	-38.4

- NOTES:
1. Peak detector is used for the emission measurement.
 2. All measurements were made at 3 meters. Radiated emissions not detected at the 3-meter distance were measured at 0.3-meter and an inverse proportional extrapolation was performed to compare the signal level to the 3-meter limit. No other radiated emissions than those reported were detected at a test distance of 0.3-meter.
 3. Negative value in the margin column shows emission below limit.
 4. Horn antenna is used for the emission over 1000MHz.
 5. Emission (the row indicated by ***bold italic***) within the restricted band meets the requirement of FCC Part 15 Section 15.205 / RSS-210 Section 2.2.

TEST REPORT

Mode: TX-Channel 78 (Bluetooth 4.0)

Table 6, Handset

Polarization	Frequency (MHz)	Reading (dBμV)	Pre-Amp Gain (dB)	Antenna Factor (dB)	Net at 3m - Peak (dBμV/m)	Calculated at 3m (dBμV/m)	Average Limit at 3m (dBμV/m)	Margin (dB)
H	2480.000	82.4	33	29.4	78.8	78.8	94.0	-15.2
H	4960.000	34.2	33	34.9	36.1	36.1	54.0	-17.9
H	7440.000	20.4	33	37.9	25.3	25.3	54.0	-28.7
H	9920.000	17.9	33	40.4	25.3	25.3	54.0	-28.7
H	12400.000	17.2	33	40.5	24.7	24.7	54.0	-29.3
H	14880.000	19.3	33	38.4	24.7	24.7	54.0	-29.3

Polarization	Frequency (MHz)	Reading (dBμV)	Pre-Amp Gain (dB)	Antenna Factor (dB)	Net at 3m - Peak (dBμV/m)	Peak Limit at 3m (dBμV/m)	Margin (dB)
H	2480.000	96.3	33	29.4	92.7	114.0	-21.3
H	4960.000	47.3	33	34.9	49.2	74.0	-24.8
H	7440.000	33.7	33	37.9	38.6	74.0	-35.4
H	9920.000	30.3	33	40.4	37.7	74.0	-36.3
H	12400.000	29.7	33	40.5	37.2	74.0	-36.8
H	14880.000	30.8	33	38.4	36.2	74.0	-37.8

- NOTES:
1. Peak detector is used for the emission measurement.
 2. All measurements were made at 3 meters. Radiated emissions not detected at the 3-meter distance were measured at 0.3-meter and an inverse proportional extrapolation was performed to compare the signal level to the 3-meter limit. No other radiated emissions than those reported were detected at a test distance of 0.3-meter.
 3. Negative value in the margin column shows emission below limit.
 4. Horn antenna is used for the emission over 1000MHz.
 5. Emission (the row indicated by ***bold italic***) within the restricted band meets the requirement of FCC Part 15 Section 15.205 / RSS-210 Section 2.2.

TEST REPORT

Mode: Bluetooth Talk

Table 7, Handset

Polarization	Frequency (MHz)	Reading (dBμV)	Pre-amp (dB)	Antenna Factor (dB)	Net at 3m (dBμV/m)	Limit at 3m (dBμV/m)	Margin (dB)
V	72.044	17.7	16	7.0	8.7	40.0	-31.3
V	93.981	17.7	16	11.0	12.7	43.5	-30.9
V	113.116	22.2	16	14.0	20.2	43.5	-23.3
V	131.519	21.4	16	14.0	19.4	43.5	-24.1
V	218.903	17.8	16	17.0	18.8	46.0	-27.2
V	721.394	10.6	16	30.0	24.6	46.0	-21.4

- NOTES:
1. Peak Detector Data unless otherwise stated.
 2. All measurements were made at 3 meters. Harmonic emissions not detected at the 3-meter distances were measured at 0.3-meter and an inverse proportional extrapolation was performed to compare the signal level to the 3-meter limit. No other harmonic emissions than those reported were detected at a test distance of 0.3-meter.
 3. Negative sign in the column shows value below limit.
 4. Horn antenna is used for the emission over 1000MHz.
 5. Emission (the row indicated by ***bold italic***) within the restricted band meets the requirement of FCC Part 15 Section 15.205 / RSS-210 4.1.
 6. Measurement Uncertainty is ±5.3dB at a level of confidence of 95%.

TEST REPORT

4.2.3 Transmitter Duty Cycle Calculation

Based on the Bluetooth Specification Version 2.0 / 2.1 + EDR, the transmitter ON time for each timeslot of Bluetooth is 625µs. DH5 has the maximum duty cycle, which consists of 5 continuous Tx slots and 1 Rx slot. Therefore one hopset take $(5+1) \times 625\mu\text{s} = 3.75\text{ms}$. For one period for a pseudo-random hopping through at least 20 RF channels in adaptive mode (worst case), it take: $20 \times 3.75\text{ms} = 75\text{ms}$.

The dwell time for DH5 is $5 \times 625\mu\text{s} = 3.125\text{ms}$

For the worst case calculation, there are two transmissions might occur in 100ms.

Therefore,

$$\begin{aligned}\text{Duty Cycle (DC)} &= \text{Maximum On time in } 100\text{ms}/100\text{ms} \\ &= 3.125\text{ms} \times 2 / 100\text{ms} \\ &= 0.0625\end{aligned}$$

$$\begin{aligned}\text{Average Factor (AF) of Bluetooth in dB} &= 20 \log_{10} (0.0625) \\ &= -24.0\text{dB}\end{aligned}$$

TEST REPORT

4.3 Radiated Emission on the Bandedge

From the following plots, they show that the fundamental emissions are confined in the specified band (2400MHz and 2483.5MHz). In case of emissions up to two standard bandwidths away from the bandedge, the delta measurement technique is used for determining bandedge compliance. Standard bandwidth is the bandwidth specified by ANSI C63.4 (2014) for frequency being measured.

Emissions radiated outside of the specified frequency bands, except harmonics, are attenuated by 50 dB below the level of the fundamental or to the general radiated emission limits in FCC Part 15 Section 15.209 / Table 4 of RSS-Gen, whichever is the lesser attenuation, which meet the requirement of FCC Part 15 Section 15.249(d) / RSS-210 A2.9(b).

The plots of radiated emission on the bandedge are saved as below.

TEST REPORT

BASE UNIT WITH BLUETOOTH 3.0 PORTION, LOWEST CHANNEL

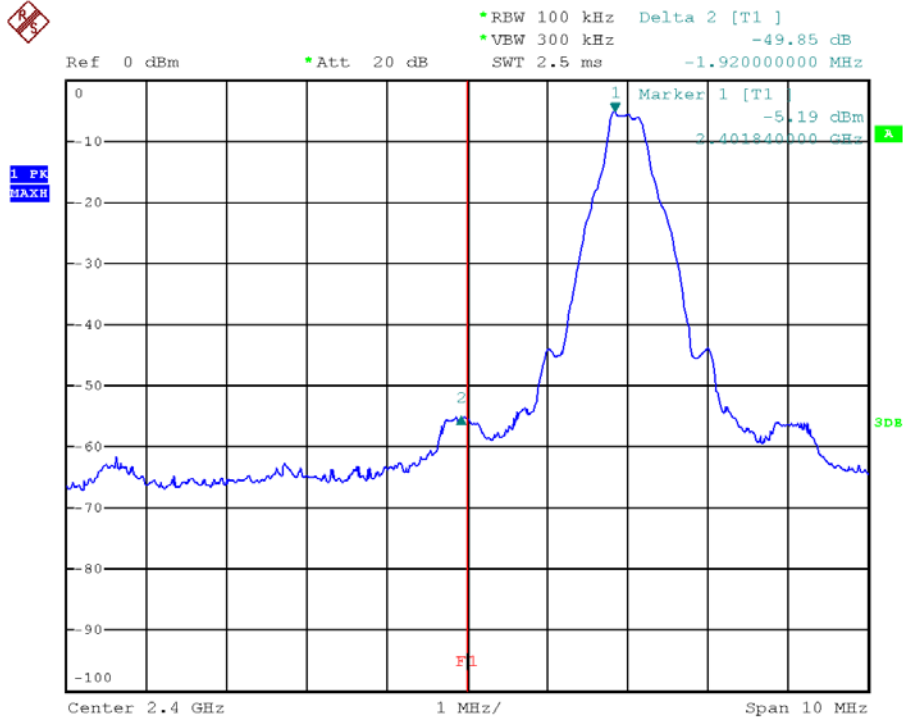

BASE UNIT WITH BLUETOOTH 3.0 PORTION, HIGHEST CHANNEL

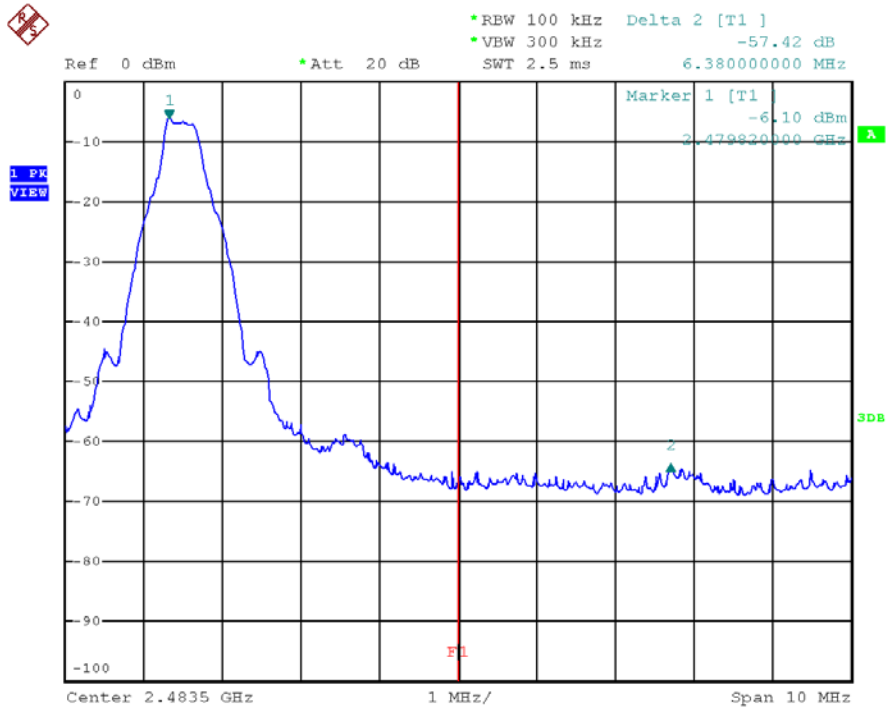

TEST REPORT

BASE UNIT WITH BLUETOOTH 4.0 PORTION, LOWEST CHANNEL

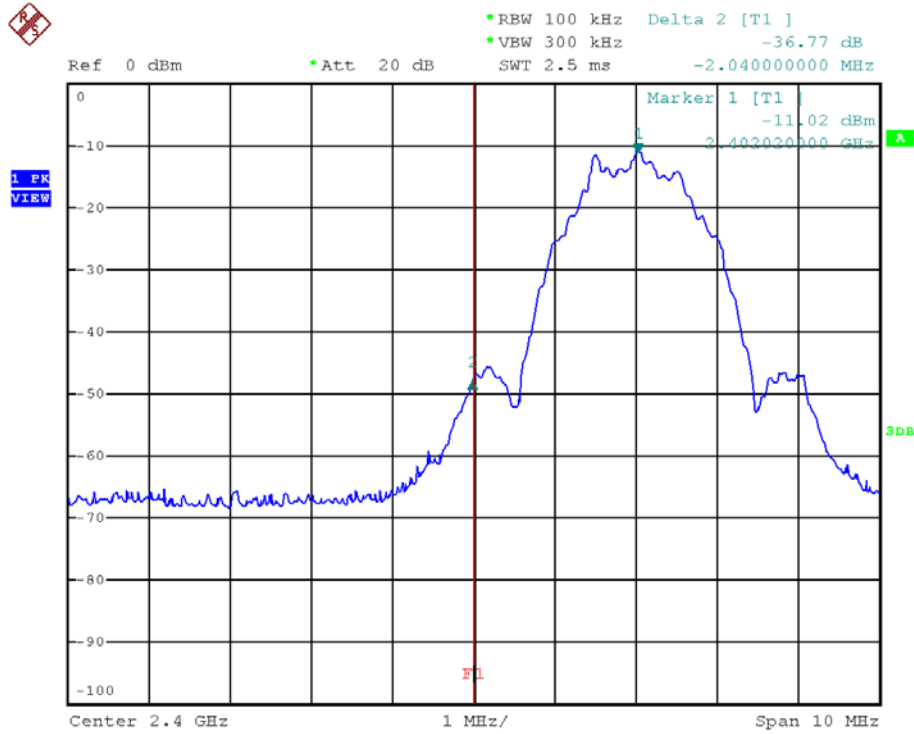

BASE UNIT WITH BLUETOOTH 4.0 PORTION, HIGHEST CHANNEL

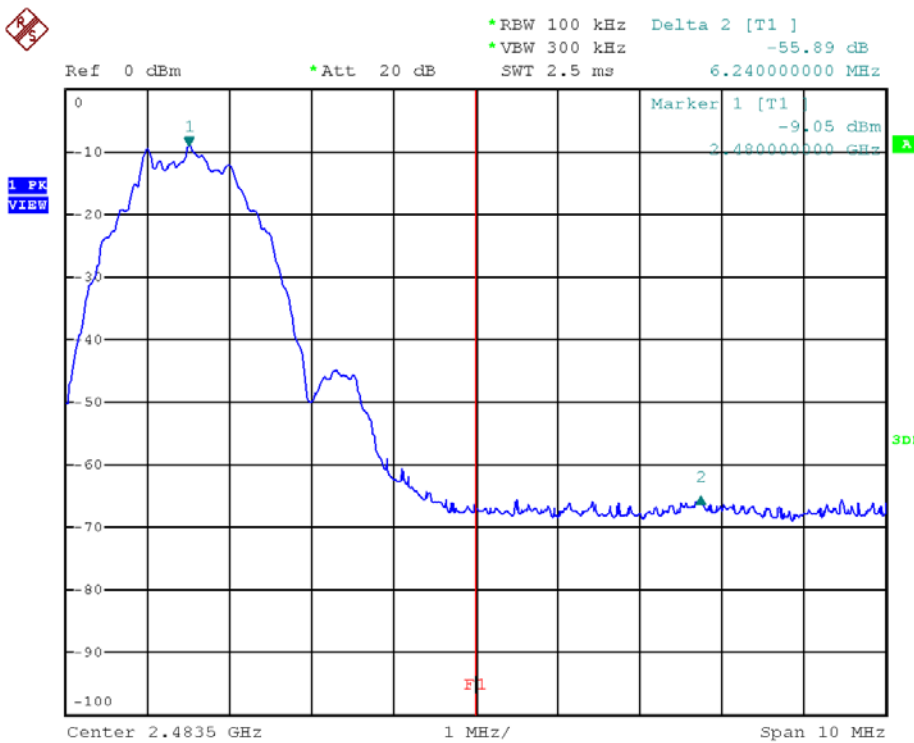

TEST REPORT

Bandedge compliance is determined by applying marker-delta method, i.e.

Resultant Field Strength = Fundamental Emissions - Delta from the plot

Resultant field strength for the lowest and/or highest channel(s), with corresponding average values are calculated as follows:

Bluetooth 3.0

Channel	Fundamental Emission (dBµV/m)	Delta from the Plot (dB)	Resultant Field Strength (dBµV/m)	Average Limit (dBµV/m)	Margin (dB)
Lowest	71.9	49.85	22.05	54	-31.95
Highest	69.6	57.42	12.18	54	-41.82

Channel	Fundamental Emission (dBµV/m)	Delta from the Plot (dB)	Resultant Field Strength (dBµV/m)	Peak Limit (dBµV/m)	Margin (dB)
Lowest	95.9	49.85	46.05	74	-27.95
Highest	93.6	57.42	36.18	74	-37.82

Bluetooth 4.0

Channel	Fundamental Emission (dBµV/m)	Delta from the Plot (dB)	Resultant Field Strength (dBµV/m)	Average Limit (dBµV/m)	Margin (dB)
Lowest	75.4	36.77	38.63	54	-15.37
Highest	78.8	55.89	22.91	54	-31.09

Channel	Fundamental Emission (dBµV/m)	Delta from the Plot (dB)	Resultant Field Strength (dBµV/m)	Peak Limit (dBµV/m)	Margin (dB)
Lowest	95.1	36.77	58.33	74	-15.67
Highest	92.7	55.89	36.81	74	-37.19

The resultant field strength meets the general radiated emission limit in Table 4 of RSS-Gen, which does not exceed 74dBµV/m for peak limit and also 54dBµV/m for average limit.

TEST REPORT

4.4 AC Power Line Conducted Emission

- [×] Not applicable – EUT is only powered by battery for operation.
- [] EUT connects to AC power line. Emission Data is listed in following pages.
- [] Base Unit connects to AC power line and has transmission. Handset connects to AC power line but has no transmission. Emission Data of Base Unit is listed in following pages.

TEST REPORT

5.0 EQUIPMENT LIST

1) Radiated Emissions Test

Equipment	EMI Test Receiver	Spectrum Analyzer	Biconical Antenna
Registration No.	EW-3156	EW-2253	EW-0571
Manufacturer	R&S	R&S	EMCO
Model No.	ESR26	FSP40	3104C
Calibration Date	August 01, 2019	November 18, 2019	July 23, 2019
Calibration Due Date	August 01, 2020	November 18, 2020	January 23, 2021

Equipment	Log Periodic Antenna	BiConiLog Antenna (30MHz - 6GHz)	Double Ridged Guide Antenna
Registration No.	EW-0447	EW-3408	EW-1133
Manufacturer	EMCO	EMCO	EMCO
Model No.	3146	3142E	3115
Calibration Date	September 25, 2019	April 25, 2019	November 29, 2018
Calibration Due Date	May 25, 2021	October 25, 2020	May 29, 2020

Equipment	Pyramidal Horn Antenna (18.0 - 26.5)GHz	12m Double Shield RF Cable (20MHz to 6GHz)	High Frequency Coaxial Cable Assembly (4 pcs)
Registration No.	EW-0905	EW-1852	EW-3126
Manufacturer	EMCO	RADIALL	GREATBILLION
Model No.	3160-09	N(m)-RG142 - N(m)	SMAm st - SMA m ra 0.6m 18GHz
Calibration Date	July 23, 2019	March 04, 2019	June 17, 2019
Calibration Due Date	January 23, 2021	March 04, 2020	June 17, 2020

2) Conducted Emissions Test

Equipment	EMI Test Receiver	LISN	RF Cable 9kHz to 1000MHz
Registration No.	EW-2251	EW-2501	EW-3170
Manufacturer	R&S	R&S	N/A
Model No.	ESCI	ENV-216	9kHz to 1000MHz
Calibration Date	June 21, 2019	May 10, 2019	May 28, 2019
Calibration Due Date	June 21, 2020	May 10, 2020	May 28, 2020

3) Bandedge Measurement Test

Equipment	Spectrum Analyzer
Registration No.	EW-2253
Manufacturer	R&S
Model No.	FSP40
Calibration Date	November 18, 2019
Calibration Due Date	November 18, 2020

END OF TEST REPORT