

TEST REPORT

Report Number: 24020910HKG-002

Class II Permissive Change of 47 CFR Part 15 Certification
Class II Permissive Change of RSS-213 Issue 3 Equipment Certification

Unlicensed Personal Communication Service Devices /
2GHz License-exempt Personal Communications Service Devices

(Speaker Box)

FCC ID: EW780-1553-00

IC : 1135B-155300

Prepared and Checked by:

Approved by:

Signed on File

Leung Chiu Kuen, Stanley
Engineer

Tang Kwan Mo, Jess
Assistant Supervisor

Date: Jul 11, 2024

Intertek's standard Terms and Conditions can be obtained at our website <http://www.intertek.com/terms/>.

The test report only allows to be revised within the retention period unless further standard or the requirement was noticed.

This report is for the exclusive use of Intertek's Client and is provided pursuant to the agreement between Intertek and its Client. Intertek's responsibility and liability are limited to the terms and conditions of the agreement. Intertek assumes no liability to any party, other than to the Client in accordance with the agreement, for any loss, expense or damage occasioned by the use of this report. Only the Client is authorized to permit copying or distribution of this report and then only in its entirety. Any use of the Intertek name or one of its marks for the sale or advertisement of the tested material, product or service must first be approved in writing by Intertek. The observations and test results in this report are relevant only to the sample tested. This report by itself does not imply that the material, product, or service is or has ever been under an Intertek certification program.

© 2017 Intertek

TEST REPORT

GENERAL INFORMATION

Grantee:	VTech Telecommunications Ltd.
Grantee Address:	23/F., Tai Ping Industrial Centre, Block 1, 57 Ting Kok Road, Tai Po, Hong Kong.
Manufacturer Name:	VTech (Dongguan) Telecommunications Limited
Manufacturer Address:	VTech Science Park, Xia Ling Bei Management Zone, Liaobu, Dongguan, Guangdong, China.
FCC Specification Standard:	FCC Part 15, October 1, 2022 Edition
FCC ID:	EW780-1553-00
FCC Model(s):	C620, C620 XXXXX, VCS712, VCS712 XXXXX
IC Specification Standard:	RSS-213 Issue 3, March 2015 RSS-Gen Issue 5 Amendment 2, February 2021
IC:	1135B-80155300
HVIN:	35-200980WS
PMN for snom Models C620, C620 XXXXX:	SIP Wireless Conference Phone
PMN for vtech Models VCS712, VCS712 XXXXX:	Wireless Conference Phone with Two Wireless Mics
Type of EUT:	Unlicensed Personal Communications Service Devices
Description of EUT:	SIP Wireless Conference Phone – Speaker Box
Serial Number:	CHNLB26012400021
Sample Receipt Date:	March 04, 2024
Date of Test:	March 07, 2024 to March 20, 2024
Report Date:	July 11, 2024
Environmental Conditions:	Temperature: +10 to 40°C Relative Humidity: 10 to 90%
Conclusion:	Test was conducted by client submitted sample. The submitted sample as received complied with the 47 CFR Part 15 / RSS-213 Issue 3 Certification.

TEST REPORT

TABLE OF CONTENTS

1.0	TEST RESULTS SUMMARY & STATEMENT OF COMPLIANCE	4
1.1	Summary of Test Results	4
1.2	Statement of Compliance	5
2.0	GENERAL DESCRIPTION.....	6
2.1	Product Description	6
2.2	Technical Description.....	6
2.3	Test Methodology.....	6
2.4	Test Facility	6
3.0	SYSTEM TEST CONFIGURATION.....	7
3.1	Justification	7
3.2	Radiated Emission Test Setup.....	8
3.3	AC Line Conducted Emission Test Setup	9
3.4	Conducted Emission Test Configuration.....	9
3.5	Conducted Monitoring and Operational Test Configuration	10
3.6	EUT Exercising Software	10
3.7	Details of EUT and Description of Accessories	11
3.8	Measurement Uncertainty	11
4.0	MEASUREMENT RESULTS.....	12
4.1	Emissions Outside the Sub-Band	12
4.2	AC Power Line Conducted Emissions.....	19
5.0	EQUIPMENT LIST.....	23

TEST REPORT

1.0 TEST RESULTS SUMMARY & STATEMENT OF COMPLIANCE

1.1 Summary of Test Results

Test Items	General Technical Requirements			Results	Details See Section
	RSS-213 / RSS-Gen [#] Clause	FCC Part 15 Section	Test Procedure ANSI C63.17 / ANSI C63.4*		
AC Power Line Conducted Emissions from EUT	5.4	15.315	7 *	Pass	4.2

TEST REPORT

1.1 Summary of Test Results

Test Items	Specific Requirements for UPCS Device			Results	Details See Section
	RSS-213 Clause	FCC Part 15 Section	Test Procedure ANSI C63.17		
Emissions Outside the Sub-Band	5.8.1	15.323(d)	6.1.6.2	Pass	4.1

1.2 Statement of Compliance

The equipment under test is found to be complying with the following standards:

- FCC Part 15, October 1, 2022 Edition
- RSS-213 Issue 3, March 2015
- RSS-Gen Issue 5 Amendment 2, February 2021

TEST REPORT

2.0 GENERAL DESCRIPTION

2.1 Product Description

The C620 (35-200980WS) is a SIP Wireless Conference Phone – Speaker Box. It operates at frequency range of 1921.536MHz to 1928.448MHz with 5 channels (1921.536MHz, 1923.264MHz, 1924.992MHz, 1926.720MHz and 1928.448MHz). The Speaker Box is powered by an adaptor 100-240VAC 50/60Hz 1.0A or is powered by a Ni-MH type rechargeable battery pack (4000mAh 7.2VDC).

The antennas used in Speaker Box are integral, and the test sample is a prototype.

For FCC, the Model(s): C620 XXXXX, VCS712 and VCS712 XXXXX are the same as the Model: C620 in electronics/electrical designs including software & firmware, PCB layout and construction design/physical design/enclosure as declared by client. The only differences between these models are color, model number and trade name to be sold for marketing purpose as declared by client. Suffix (“X, X, X, X, X” of “C620 XXXXX and VCS712 XXXXX”) can be 0-9, a-z, A-Z or blank to represent different packaging or color options as declared by client.

2.2 Purpose of Change

The purpose of change is saved with filename: product change.pdf.

2.3 Test Methodology

The radiated emission measurements for unintentional radiator and AC power line-conducted emission measurements were performed according to the test procedures specified in ANSI C63.4 (2014). The radiated emission measurements for intentional radiator contained in UPCS device, conducted emission measurements were performed according to the test procedures specified in ANSI C63.17 (2013). All radiated measurements were performed in radiated emission test site. Preliminary scans were performed in the radiated emission test site only to determine worst case modes. All radiated tests were performed at an antenna to EUT distance of 3 meters, unless stated otherwise in the "**Justification Section**" of this Application.

2.4 Test Facility

The radiated emission test site, AC power line conducted measurement facility and antenna port conducted measurement facility used to collect the radiated data, AC Power Line conducted data are at Intertek Testing Services Hong Kong Limited, which is located at Workshop No. 3, G/F., World-Wide Industrial Centre, 43-47 Shan Mei Street, Fo Tan, Sha Tin, N.T., Hong Kong SAR, China. This test facility and site measurement data have been fully placed on file with FCC and IC CABID “HKAP01”.

TEST REPORT

3.0 SYSTEM TEST CONFIGURATION

3.1 Justification

For emissions testing, the equipment under test (EUT) was set up to transmit continuously in burst mode with pseudo-random data to simplify the measurement methodology. Care was taken to ensure proper power supply voltages during testing. During testing, all cables (if any) were manipulated to produce worst-case emissions.

The Speaker Box was powered by an adaptor 100-240VAC 50/60Hz 1.0A to 12VDC 3.0A and/or a fully charged Ni-MH type rechargeable battery pack (7.2V 4000mAh).

For the measurements, the EUT was attached to a plastic stand if necessary and placed on the wooden turntable. If the EUT is attached to accessories, they were connected and operational (as typical as possible).

The signal was maximized through rotation and placement in the three orthogonal axes. The antenna height and polarization were varied during the search for maximum signal level. The antenna height was varied from 1 to 4 meters. Detector function was in peak mode. Radiated emissions are taken at three meters unless the signal level was too low for measurement at that distance. If necessary, a pre-amplifier was used and/or the test was conducted at a closer distance.

For UPCS transmitter radiated measurement, the spectrum analyzer resolution bandwidth was approximately 1% of EUT emission bandwidth, unless otherwise specified.

Radiated emission measurements for UPCS transmitter were performed from the lowest radio frequency signal generated in the device which is greater than 9 kHz to the tenth harmonic of the highest fundamental frequency or to 40 GHz, whichever is lower.

As the Speaker Box has 2 antennas, both have been checked. While conducting the test on one of antennas, another one was being disable its transmission. The data in this report represented the worst-case

For FCC and IC, RF module and antenna for C620 is the same with original granted model C620. Therefore, conducted emission measurement for emission bandwidth, peak transmit power, power spectral density, unwanted emission inside the sub-band, jitter, frame repetition stability, carrier stability and listen before transmit requirements for the C620 are skipped.

For AC line conducted emission test, the EUT along with its peripherals were placed on a 1.0m(W)x1.5m(L) and 0.8m in height wooden table and the EUT was adjusted to maintain a 0.4 meter space from a vertical reference plane. The EUT was connected to power mains through a line impedance stabilization network (LISN), which provided 50ohm coupling impedance for measuring instrument. The LISN housing, measuring instrument case, reference ground plane, and vertical ground plane were bounded together. The excess power cable between the EUT and the LISN was bundled.

All connecting cables of EUT and peripherals were manipulated to find the maximum emission. All relevant operation modes have been tested and the worst data is included in this report.

TEST REPORT

3.2 Radiated Emission Test Setup

The figure below shows the test setup, which is utilized to make these measurements.

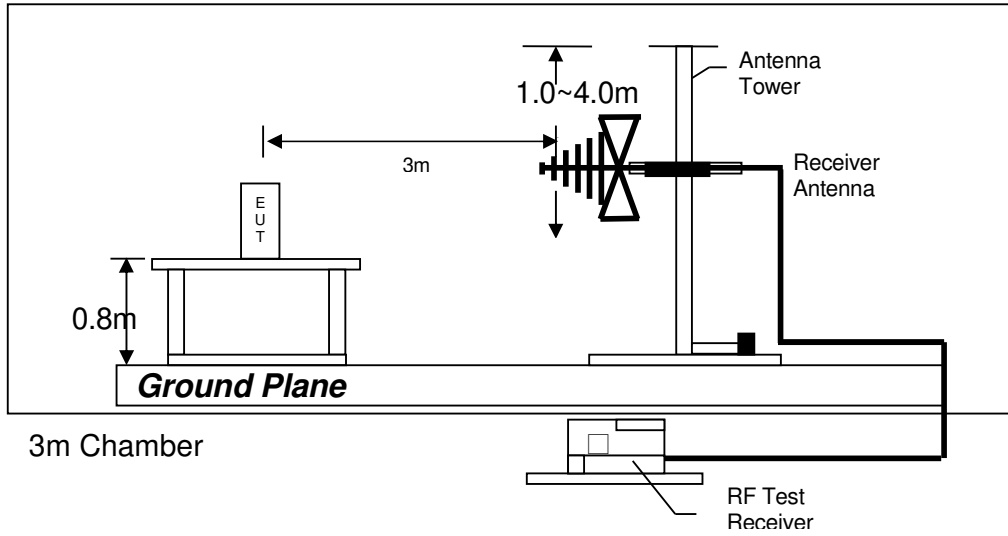

Test setup of radiated emissions up to 1GHz

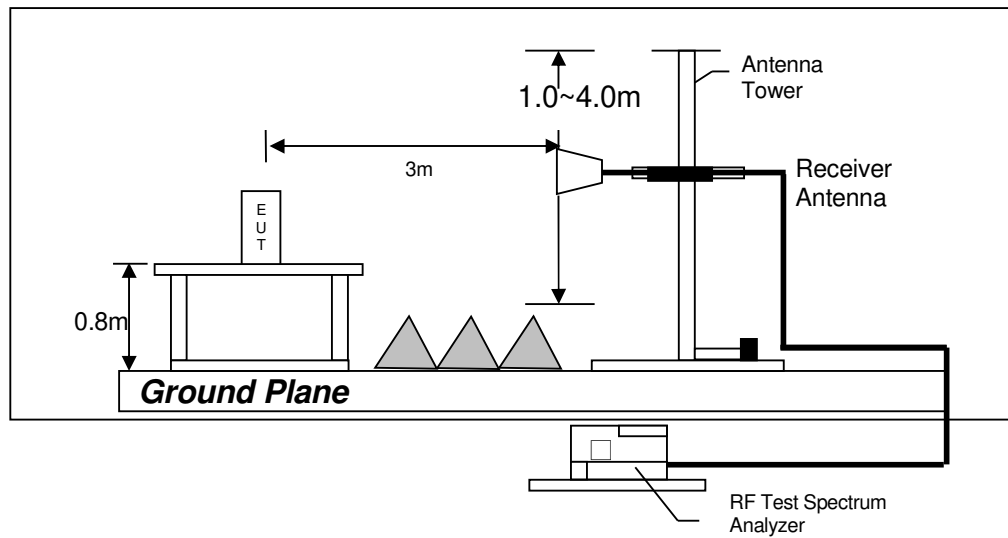

Test setup of radiated emissions above 1GHz

Figure 3.2.1

TEST REPORT

3.3 AC Line Conducted Emission Test Setup

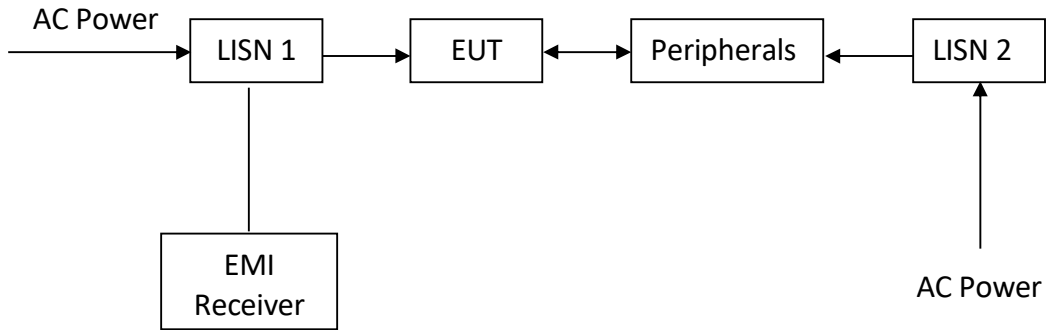

Figure 3.3.1

3.4 Conducted Emission Test Configuration

The setup and equipment setting were made in accordance with ANSI C63.17. The antenna of EUT transmitter was replaced by a coaxial cable. The impedance matching of connection, cable loss and external RF attenuator are taken into account. The EUT was arranged to communicate via a fixed carrier frequency between its transmitter and a companion device. The transmission was configured in burst mode with pseudo-random data as typical as normal operation.

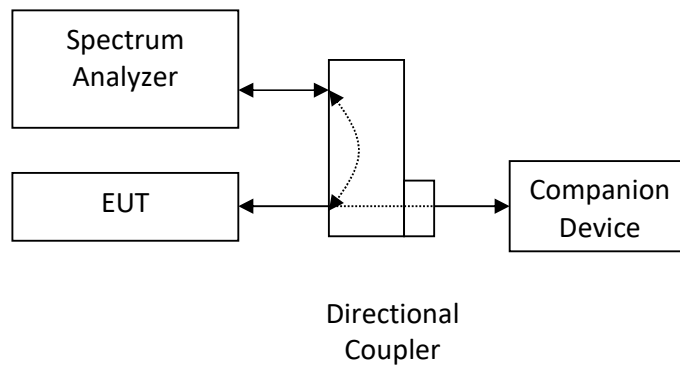

Figure 3.4.1

TEST REPORT

3.5 Conducted Monitoring and Operation Test Configuration

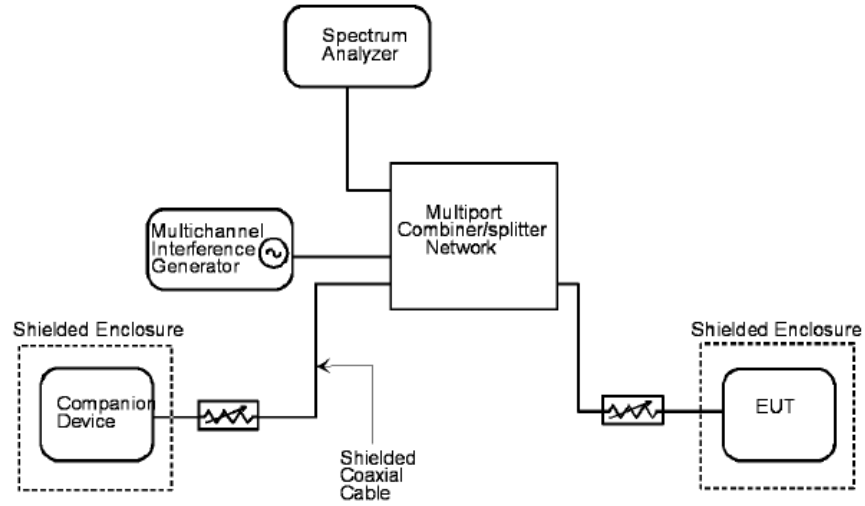

Figure 3.5.1

3.6 EUT Exercising Software

The EUT exercise program Unit tools V4.9.1 used during radiated and conducted testing was designed to exercise the various system components in a manner similar to a typical use.

TEST REPORT

3.7 Details of EUT and Description of Accessories

Details of EUT:

An AC adaptor with a charging dock, and/or a battery (provided with the unit) were used to power the device. Their descriptions are listed below.

- (1) A charging dock alternative AC adaptor with ferrite (100-240VAC 50/60Hz 1.0A to 12VDC 3.0A, Model: S042-1A120300VU, Brand: MASS POWER) (Provided by Applicant)
- (2) A "Ni-MH" Type Rechargeable Battery Pack (7.2V 4000mAh), Model: BT200660, Brand: Corun (Provided by Applicant)

Description of Accessories:

- (1) Base Unit, Model: C620, FCC ID: EW780-0899-00 (Provided by Applicant)
- (2) Wireless Mic, Model: C620, FCC ID: EW780-1553-01 (Provided by Applicant)

3.8 Measurement Uncertainty

Decision Rule for compliance: For FCC/IC standard, the measured value must be within the limits of applicable standard without accounting for the measurement uncertainty. For EN/IEC/HKTA/HKTC standard, conformity rules will be used as per standard directly excepted EN/IEC 61000-3-2, EN/IEC 61000-3-3, HKTA1004, HKCA1008, HKTA1019, HKTA1020, HKTA1041 and HKTA1044. The values of the Measurement uncertainty for radiated emission test, AC line conducted emission test are $\pm 5.3\text{dB}$, $\pm 4.2\text{dB}$ respectively.

Uncertainty and Compliance - Unless the standard specifically states that measured values are to be extended by the measurement uncertainty in determining compliance, all compliance determinations are based on the actual measured value.

TEST REPORT

4.0 MEASUREMENT RESULTS

4.1 Emissions Outside the Sub-Band, FCC Rule 15.323(d)/RSS-213 Clause 5.8.1:

Emissions outside the sub-band shall be attenuated below a reference power of 112 mW (20.5 dBm) as follows:

- (1) 30 dB between the band edge and 1.25 MHz above or below the band;
- (2) 50 dB between 1.25 and 2.5 MHz above or below the band; and
- (3) 60 dB at 2.5 MHz or greater above or below the band, or shall meet the requirement of FCC Rule 15.319(g) which shall not exceed the limits of FCC Rule 15.209/RSS-Gen Clause 8.9.

Example:

Calculation of Limit for emissions between the band edge and 1.25 MHz (1920.000 – 1918.750 MHz)

The emissions shall not exceed the Limit: 20.5 dBm – 30 dB = -9.5 dBm

Measurements are made in accordance with ANSI C63.17 sub-clause 6.1.6.2. Radiated emissions test method is used. Emissions that are directly caused by digital circuits in the transmit path and transmitter portion are measured.

Test setup is shown in section 3.2 Figure 3.2.1

Test Results:

Channel	Carrier Frequency (MHz)	Measured Band (MHz)	Limit (dBm)	Results
Lowest	1921.536	1920.000 - 1918.750	-9.5	Pass
		1918.750 - 1917.500	-29.5	Pass
		0.009 - 1917.500 & 1932.500 - 19300.000	-39.5 / FCC Rule 15.209/ RSS-Gen Clause 8.9	Pass
Highest	1928.448	1930.000 - 1931.250	-9.5	Pass
		1931.250 - 1932.500	-29.5	Pass
		0.009 – 1917.500 & 1932.500 - 19300.000	-39.5 / FCC Rule 15.209/ RSS-Gen Clause 8.9	Pass

TEST REPORT

4.1.1 Radiated Emissions Configuration Photographs:

Worst Case Radiated Emission at
2305.812 MHz

The worst case radiated emission configuration photographs are saved with filename:
config photos.pdf

4.1.2 Radiated Emissions Data:

Data are included of the worst case configuration (the configuration which resulted in the highest emission levels). A sample calculation, configuration photographs and data tables of the emissions are included. All measurements were performed with peak detection unless otherwise specified.

The data in table 1-3 list the significant emission frequencies, the limit and the margin of compliance.

Judgement:

Passed by 7.9 dB margin

TEST REPORT

RADIATED EMISSIONS DATA

Mode: DECT Transmission and Charging

Table 1

Pursuant to FCC Part 15 Section 15.323(d) / RSS-213 Clause 5.8.1 Emissions Requirements

Lowest Channel

Polarization	Frequency (MHz)	Measured Power (dBm)	Power Limit (dBm)	Margin (dB)
V	1917.335	-59.2	-39.5	-19.7
V	1918.514	-50.6	-29.5	-21.1
V	1919.947	-40.6	-9.5	-31.1
V	2305.812	-47.4	-39.5	-7.9
V	2881.688	-56.2	-39.5	-16.7
V	3843.072	-55.2	-39.5	-15.7
V	5764.608	-61.9	-39.5	-22.4
H	7686.144	-58.0	-39.5	-18.5
H	9607.680	-61.0	-39.5	-21.5
V	11529.216	-60.2	-39.5	-20.7

- Notes:
1. Peak detector is used for the emission measurement.
 2. All measurements were made at 3 meters.
 3. Negative value in the margin column shows emission below limit.

TEST REPORT

RADIATED EMISSIONS DATA

Mode: DECT Transmission and Charging

Table 2

Pursuant to FCC Part 15 Section 15.323(d) / RSS-213 Clause 5.8.1 Emissions Requirements

Highest Channel

Polarization	Frequency (MHz)	Measured Power (dBm)	Power Limit (dBm)	Margin (dB)
V	1930.106	-39.1	-9.5	-29.6
V	1931.509	-51.1	-29.5	-21.6
V	1932.711	-56.0	-39.5	-16.5
V	2313.781	-51.0	-39.5	-11.5
V	3856.896	-51.3	-39.5	-11.8
H	5785.344	-69.2	-39.5	-29.7
H	7713.792	-66.8	-39.5	-27.3
V	9642.240	-60.0	-39.5	-20.5
V	11570.688	-67.4	-39.5	-27.9

- Notes:
1. Peak detector is used for the emission measurement.
 2. All measurements were made at 3 meters.
 3. Negative value in the margin column shows emission below limit.

TEST REPORT

RADIATED EMISSIONS DATA

Mode: Talk Mode and Charging

Table 3

Pursuant to FCC Part 15 Section 15.323(d) / RSS-213 Clause 5.8.1 Emissions Requirements

Polarization	Frequency (MHz)	Measured Power (dBm)	Power Limit (dBm)	Margin (dB)
V	62.374	-75.3	-39.5	-35.8
H	93.535	-62.0	-39.5	-22.5
H	111.844	-66.9	-39.5	-27.4
H	136.943	-66.2	-39.5	-26.7
H	194.779	-71.7	-39.5	-32.2
H	285.716	-54.1	-39.5	-14.6
V	374.956	-62.7	-39.5	-23.2
H	414.726	-59.7	-39.5	-20.2
V	589.084	-64.9	-39.5	-25.4
V	624.974	-63.5	-39.5	-24.0
V	960.108	-58.9	-39.5	-19.4

- Notes:
1. Peak detector is used for the emission measurement.
 2. All measurements were made at 3 meters.
 3. Negative value in the margin column shows emission below limit.

TEST REPORT

4.1.3 Field Strength Calculation

The field strength is calculated by adding the reading on the Spectrum Analyzer to the factors associated with preamplifiers (if any), antennas, cables, pulse desensitization and average factors (when specified limit is in average and measurements are made with peak detectors). A sample calculation is included below.

$$FS = RA + AF + CF - AG + PD + AV$$

Where

- FS = Field Strength in dB μ V/m
- RA = Receiver Amplitude (including preamplifier) in dB μ V
- AF = Antenna Factor in dB
- CF = Cable Attenuation Factor in dB
- AG = Amplifier Gain in dB
- PD = Pulse Desensitization in dB
- AV = Average Factor in -dB

In the radiated emission table which follows, the reading shown on the data table may reflect the preamplifier gain. An example of the calculations, where the reading does not reflect the preamplifier gain, follows:

$$FS = RA + AF + CF - AG + PD + AV$$

Example:

Assume a receiver reading of 62.0 dB μ V is obtained. The antenna factor of 7.4 dB and cable factor of 1.6 dB is added. The amplifier gain of 29.0 dB is subtracted. The pulse desensitization factor of the spectrum analyzer is 0.0 dB, and the resultant average factor is -10.0 dB. The net field strength for comparison to the appropriate emission limit is 32.0 dB μ V/m. This value in dB μ V/m is converted to its corresponding level in μ V/m.

- RA = 62.0 dB μ V
- AF = 7.4 dB
- CF = 1.6 dB
- AG = 29.0 dB
- PD = 0.0 dB
- AV = -10.0 dB

$$FS = 62.0 + 7.4 + 1.6 - 29.0 + 0.0 + (-10.0) = 32.0 \text{ dB}\mu\text{V/m}$$

$$\text{Level in } \mu\text{V/m} = \text{Common Antilogarithm } [(32.0 \text{ dB}\mu\text{V/m})/20] = 39.8 \mu\text{V/m}$$

$$\text{Level in dBm (EIRP)} = FS - 95.23 = 32 - 95.23 = -63.23 \text{ dBm}$$

$$\text{Level in dBm (ERP)} = FS - 95.23 - 2.15 = 32 - 95.23 - 2.15 = -65.38 \text{ dBm}$$

TEST REPORT

4.1.4 Average Factor Calculation and Transmitter ON Time Measurements, FCC Rule 15.35(b, c) / RSS-Gen Clause 4.5

- [] The EUT antenna output port was connected to the input of the spectrum analyzer. The analyzer center frequency was set to EUT RF channel carrier. The SPAN function on the analyzer was set to ZERO. The transmitter ON time was determined from the resultant time-amplitude display:

Please refer to the attached plots for more details:

The plots of Transmitter ON Time Measurements are as below.

- [] Please refer to the attached transmitter timing diagram that are provided by manufacturer.
- [x] Not Applicable - No average factor is required.
- [] Please refer to Technical Description (descri.pdf) for more details

TEST REPORT

4.2 AC Power Line Conducted Emissions, FCC Rule 15.315 / RSS-213 Clause 5.4 :

The AC power line conducted emission shall not exceed the limits of FCC Rule 15.207 / Table 4 in RSS-Gen Clause 7.2.4.

Measurements are made in accordance with ANSI C63.4 sub-clause 7. Emissions that are directly caused by digital circuits in the transmit path and transmitter portion are measured.

Test setup is shown in section 3.3 Figure 3.3.1.

- [] Not Applicable – EUT is only powered by battery for operation.
- [] EUT connects to AC power line. Emission Data is listed in following pages.
- [] Base Unit connects to AC power line and has transmission. Handset connects to AC power line (indirectly) but has no transmission. Emission Data of Base Unit is listed in following pages.
- [x] Speaker Box connects to AC power line (indirectly) only during charging. Emission Data is listed in following pages.

TEST REPORT

4.2.1 AC Power Line Conducted Emissions Configuration Photographs:

Worst Case AC Power Line Conducted Emission at
0.15 MHz

The worst case AC power Line conducted emission configuration photographs are saved with filename: config photos.pdf

4.2.2 AC Power Line Conducted Emissions Data:

The plot(s) and data in the following pages list the significant emission frequencies, the limit and the worst case margin of compliance.

Judgement:

Passed by 7.03 dB margin compared with quasi peak

TEST REPORT

CONDUCTED EMISSIONS DATA

Worst Case: Talk and Charging



RBW 9 kHz
MT 1 s

Att 10 dB AUTO PREAMP OFF

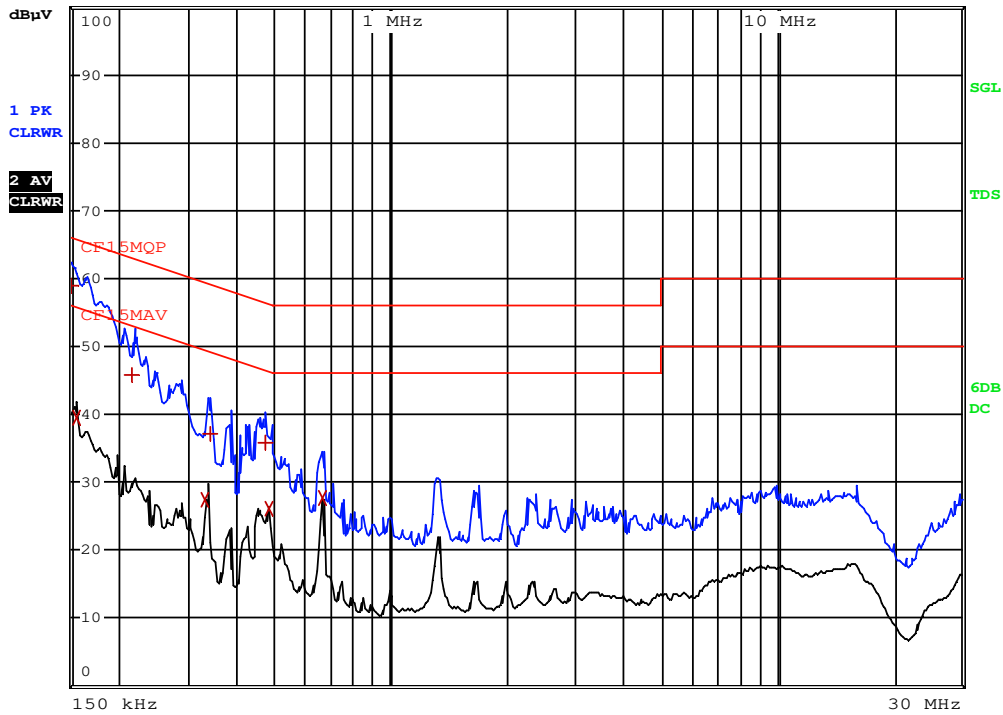

TEST REPORT

CONDUCTED EMISSIONS DATA

Worst Case: Talk and Charging

EDIT PEAK LIST (Final Measurement Results)				
Trace1:	CF15MQP			
Trace2:	CF15MAV			
Trace3:	---			
	TRACE	FREQUENCY	LEVEL dBμV	DELTA LIMIT dB
1	Quasi Peak	150 kHz	58.96 N	-7.03
2	CISPR Average	154.5 kHz	39.45 N	-16.30
1	Quasi Peak	217.5 kHz	45.79 L1	-17.11
2	CISPR Average	334.5 kHz	27.44 L1	-21.89
1	Quasi Peak	339 kHz	37.05 L1	-22.17
1	Quasi Peak	469.5 kHz	35.81 L1	-20.71
2	CISPR Average	483 kHz	26.02 L1	-20.25
2	CISPR Average	663 kHz	27.63 N	-18.36

TEST REPORT

5.0 EQUIPMENT LIST

1) Radiated Emissions Test

Equipment	EMI Test Receiver	Signal and Spectrum Analyzer (10Hz to 40GHz)	BiConiLog Antenna (30MHz - 6GHz)
Registration No.	EW-3156	EW-2466	EW-3061
Manufacturer	ROHDESCHWARZ	ROHDESCHWARZ	EMCO
Model No.	ESR	FSP	3142E
Calibration Date	January 31, 2024	October 10, 2023	August 23, 2023
Calibration Due Date	January 31, 2025	October 10, 2024	February 23, 2025

Equipment	14m Double Shield RF Cable (9kHz - 6GHz)	14m Double Shield RF Cable (1GHz - 26GHz)	Double Ridged Guide Antenna
Registration No.	EW-2376	EW-2781	EW-0194
Manufacturer	RADIALL	RADIALL	EMCO
Model No.	N(m)-BR56-BNC(m) L=14M	SMA(m)-SHF5MPU-SMA(m) R.A 14m, 26G	3115
Calibration Date	September 19, 2023	January 16, 2024	May 10, 2023
Calibration Due Date	September 19, 2024	January 16, 2025	November 10, 2024

Equipment	Log Periodic Antenna (200MHz - 2GHz)	Biconical Antenna (30MHz – 300MHz)	RF Pre-Amplifier (9kHz to 40GHz)
Registration No.	EW-3244	EW-3241	EW-3229
Manufacturer	EMCO	EMCO	BONN ELEKTRO
Model No.	3148B	3110C	BLMA 0118-5G
Calibration Date	August 30, 2022	February 26, 2022	September 26, 2023
Calibration Due Date	May 30, 2024	May 26, 2024	September 26, 2024

Equipment	1.9GHz Notch Filter	Pyramidal Horn Antenna (18.0 - 26.5)GHz
Registration No.	EW-3434	EW-0905
Manufacturer	Microwave	EMCO
Model No.	N0319501	3160-09
Calibration Date	December 20, 2023	December 15, 2023
Calibration Due Date	December 20, 2024	June 15, 2025

TEST REPORT

5.0 EQUIPMENT LIST (CONT'D)

2) Conducted Emissions Test

Equipment	EMI Test Receiver	RF Cable RG142 (9kHz-30MHz) 2.4m length	LISN
Registration No.	EW-3095	EW-2454	EW-3360
Manufacturer	ROHDESCHWARZ	RADIALL	R&S
Model No.	ESCI	BNC M ST/ 142	ENV-216
Calibration Date	January 18, 2024	June 13, 2023	April 25, 2023
Calibration Due Date	January 18, 2025	June 13, 2024	April 25, 2024

END OF TEST REPORT