

## TEST REPORT

**Report Number: 18051604HKG-001**

Application For Class II Permissive Change of 47 CFR Part 15 Certification  
Class I Permissive Change of RSS-213 Issue 3 Equipment Certification

Unlicensed Personal Communication Service Devices/  
2 GHz License-exempt Personal Communications Service Devices

(Handset)

**FCC ID: EW780-1375-00**

**IC: 1135B-80147000**

**Prepared and Checked by:**

**Approved by:**

Signed On File

Leung Chiu Kuen, Stanley  
Engineer

Tang Kwan Mo, Jess  
Lead Engineer

Date: June 11, 2018

---

Intertek's standard Terms and Conditions can be obtained at our website <http://www.intertek.com/terms/>.

The test report only allows to be revised within the retention period unless further standard or the requirement was noticed.

This report is for the exclusive use of Intertek's Client and is provided pursuant to the agreement between Intertek and its Client. Intertek's responsibility and liability are limited to the terms and conditions of the agreement. Intertek assumes no liability to any party, other than to the Client in accordance with the agreement, for any loss, expense or damage occasioned by the use of this report. Only the Client is authorized to permit copying or distribution of this report and then only in its entirety. Any use of the Intertek name or one of its marks for the sale or advertisement of the tested material, product or service must first be approved in writing by Intertek. The observations and test results in this report are relevant only to the sample tested. This report by itself does not imply that the material, product, or service is or has ever been under an Intertek certification program.

© 2017 Intertek

## TEST REPORT

### GENERAL INFORMATION

<b>Grantee:</b>	VTech Telecommunications Ltd.
<b>Grantee Address:</b>	23/F., Tai Ping Industrial Centre, Block 1, 57 Ting Kok Road, Tai Po, Hong Kong.
<b>FCC Specification Standard:</b>	FCC Part 15, October 1, 2016 Edition
<b>FCC ID:</b>	EW780-1375-00
<b>FCC Model(s):</b>	DS6251, DS6251-2, DS6251-3, DS6251-4, DS625Z-XY, DS6250, DS6250-XY
<b>IC Specification Standard:</b>	RSS-213 Issue 3, March 2015 RSS-Gen Issue 4, November 2014
<b>IC:</b>	1135B-80147000
<b>HVIN:</b>	35-201040HS
<b>Vtech Model(s):</b>	DS6251, DS6251-2, DS6251-3, DS6251-4, DS625Z-XY, DS6250, DS6250-XY
<b>PMN:</b>	2-Line Cordless Answering System
<b>Type of EUT:</b>	Unlicensed Personal Communications Service Devices
<b>Description of EUT:</b>	DECT 6.0 Cordless Phone - Handset
<b>Serial Number:</b>	N/A
<b>Sample Receipt Date:</b>	May 28, 2018
<b>Date of Test:</b>	May 28 - Jun 5, 2018
<b>Report Date:</b>	June 11, 2018
<b>Environmental Conditions:</b>	Temperature: +10 to 40°C Humidity: 10 to 90%

**TEST REPORT**

**TABLE OF CONTENTS**

**1.0 TEST RESULTS SUMMARY & STATEMENT OF COMPLIANCE ..... 4**

    1.1 Summary of Test Results .....4

    1.2 Statement of Compliance .....4

**2.0 GENERAL DESCRIPTION ..... 5**

    2.1 Product Description.....5

    2.2 Purpose of Change .....5

    2.3 Test Methodology .....5

    2.4 Test Facility .....5

**3.0 SYSTEM TEST CONFIGURATION ..... 6**

    3.1 Justification .....6

    3.2 Radiated Emission Test Setup .....7

    3.3 AC Line Conducted Emission Test Setup.....8

    3.4 Conducted Emission Test Configuration.....9

    3.5 Conducted Monitoring and Operational Test Configuration .....9

    3.6 EUT Exercising Software.....9

    3.7 Details of EUT and Description of Accessories.....10

    3.8 Measurement Uncertainty .....10

**4.0 MEASUREMENT RESULTS ..... 11**

    4.1 Emissions Outside the Sub-Band .....11

        4.1.1 Radiated Emissions Configuration Photographs .....12

        4.1.2 Radiated Emissions Data .....12

        4.1.3 Field Strength Calculation.....16

        4.1.4 Average Factor Calculation and Transmitter ON Time Measurements.....17

**5.0 EQUIPMENT LIST ..... 18**

**TEST REPORT**

**1.0 TEST RESULTS SUMMARY & STATEMENT OF COMPLIANCE**

1.1 Summary of Test Results

Test Items	Specific Requirements for UPCS Device			Results	Details See Section
	RSS-213 Clause	FCC Part 15 Section	Test Procedure ANSI C63.17		
Emissions Outside the Sub-Band	5.8.1	15.323(d)	6.1.6.2	Pass	4.1

1.2 Statement of Compliance

The equipment under test is found to be complying with the following standards:

- FCC Part 15, October 1, 2016 Edition
- RSS-213 Issue 3, March 2015
- RSS-Gen Issue 4, November 2014

## TEST REPORT

### 2.0 GENERAL DESCRIPTION

#### 2.1 Product Description

The DS6251 is a DECT 6.0 Cordless Phone - Handset. It operates at frequency range of 1921.536MHz to 1928.448MHz with 5 channels (1921.536MHz, 1923.264MHz, 1924.992MHz, 1926.720MHz and 1928.448MHz). The Handset is powered by a Ni-MH type rechargeable battery pack (2.4V 400mAh).

The antenna used in handset is integral, and the test sample is a prototype.

For FCC, the Model(s): DS6251-2, DS6251-3, DS6251-4, DS625Z-XY, DS6250 and DS6250-XY are the same as the Model: DS6251 in electronics/electrical designs including software & firmware, PCB layout and construction design/physical design/enclosure. The only differences between these models are model number, color, package type, and number of handset and charger to be sold for marketing purpose. Suffix ("X,Y,Z" in DS625Z-XY and DS6250-XY) indicates different package type (material), different number of handset and extra charger, and different color of enclosure.

Connection between the device and the telephone network is accomplished through the use of USOC RJ11C in the 2-wire loop calling central office line.

#### 2.2 Purpose of Change

The purpose of change is saved with filename: product change.pdf

#### 2.3 Test Methodology

The radiated emission measurements for unintentional radiator (if any) were performed according to the test procedures specified in ANSI C63.4 (2014). The radiated emission measurements for intentional radiator contained in UPCS device, conducted emission measurements, Listen Before Transmit (LBT) tests, Time Frame and Frequency Stability tests were performed according to the test procedures specified in ANSI C63.17 (2013). All radiated measurements were performed in radiated emission test site. Preliminary scans were performed in the radiated emission test site only to determine worst case modes. All radiated tests were performed at an antenna to EUT distance of 3 meters, unless stated otherwise in the "Justification Section" of this Application. All other measurements were made in accordance with the procedures in 47 CFR Part 2 / RSS-Gen Issue 4 (2014).

#### 2.4 Test Facility

The radiated emission test site, facility and antenna port conducted measurement facility used to collect the radiated data and conductive data are at Intertek Testing Services Hong Kong Ltd., which is located at Workshop No. 3, G/F., World-Wide Industrial Centre, 43-47 Shan Mei Street, Fo Tan, Sha Tin, N.T., Hong Kong. This test facility and site measurement data have been fully placed on file with FCC and Industry Canada.

## TEST REPORT

### 3.0 SYSTEM TEST CONFIGURATION

#### 3.1 Justification

For emissions testing, the equipment under test (EUT) was set up to transmit continuously in burst mode with pseudo-random data to simplify the measurement methodology. Care was taken to ensure proper power supply voltages during testing. During testing, all cables (if any) were manipulated to produce worst-case emissions.

The handset was powered by a fully charged battery.

For the measurements, the EUT was attached to a plastic stand if necessary and placed on the wooden turntable. If the EUT is attached to accessories, they were connected and operational (as typical as possible).

The signal was maximized through rotation and placement in the three orthogonal axes. The antenna height and polarization were varied during the search for maximum signal level. The antenna height was varied from 1 to 4 meters. Detector function was in peak mode. Radiated emissions are taken at three meters unless the signal level was too low for measurement at that distance. If necessary, a pre-amplifier was used and/or the test was conducted at a closer distance.

For UPCS transmitter radiated measurement, the spectrum analyzer resolution bandwidth was approximately 1% of EUT emission bandwidth, unless otherwise specified.

Radiated emission measurements for UPCS transmitter were performed from the lowest radio frequency signal generated in the device which is greater than 9 kHz to the tenth harmonic of the highest fundamental frequency or to 40 GHz, whichever is lower.

RF module and antenna for handset of DS6251 is the same with original granted model DS6251. Therefore conducted emission measurement for emission bandwidth, peak transmit power, power spectral density, unwanted emission inside the sub-band, jitter, frame repetition stability, carrier stability and listen before transmit requirements for DS6251 are skipped.

All connecting cables of EUT and peripherals were manipulated to find the maximum emission.

All relevant operation modes have been tested, and the worst case data is included in this report.

**TEST REPORT**

3.2 Radiated Emission Test Setup

The figure below shows the test setup, which is utilized to make these measurements.

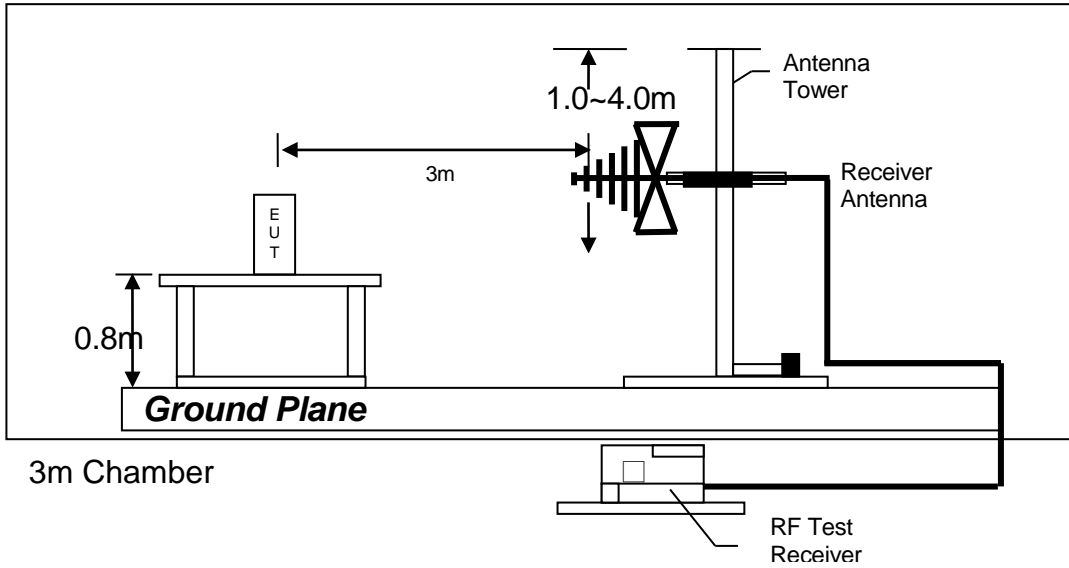

Test setup of radiated emissions up to 1GHz

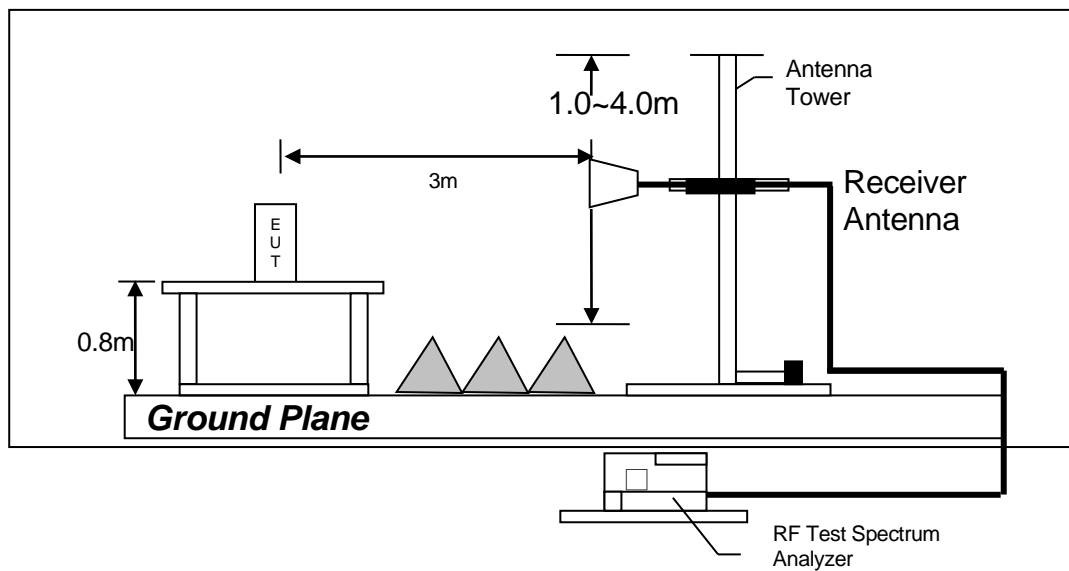

Test setup of radiated emissions above 1GHz

Figure 3.2.1

## TEST REPORT

### 3.3 AC Line Conducted Emission Test Setup

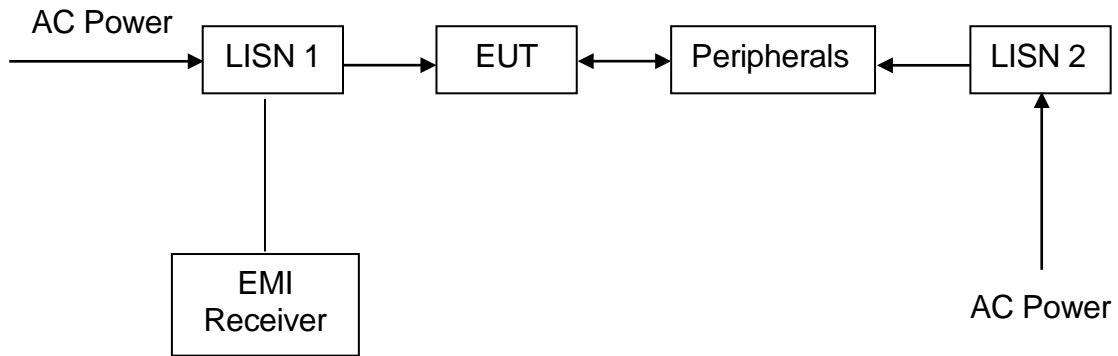

Figure 3.3.1

## TEST REPORT

### 3.4 Conducted Emission Test Configuration

The setup and equipment setting were made in accordance with ANSI C63.17. The antenna of EUT transmitter was replaced by a coaxial cable. The impedance matching of connection, cable loss and external RF attenuator are taken into account. The EUT was arranged to communicate via a fixed carrier frequency between its transmitter and a companion device. The transmission was configured in burst mode with pseudo-random data as typical as normal operation.

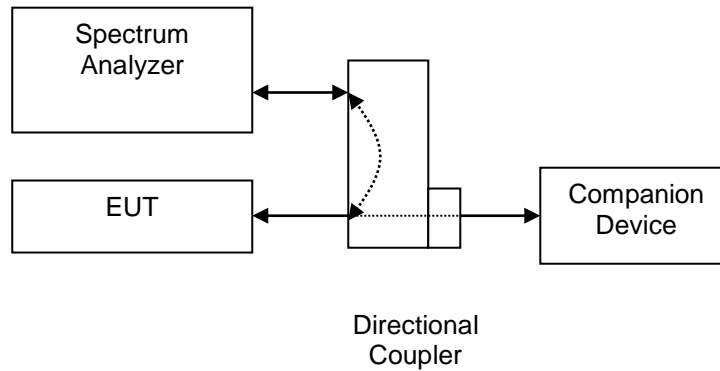

Figure 3.4.1

### 3.5 Conducted Monitoring and Operation Test Configuration

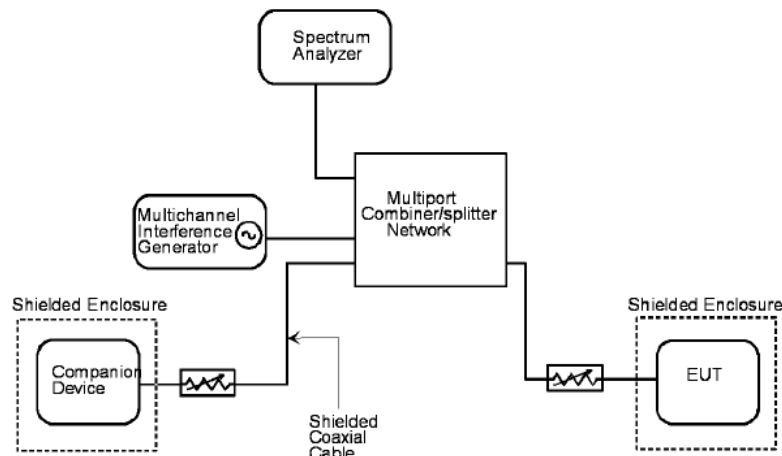

Figure 3.5.1

### 3.6 EUT Exercising Software

The EUT exercise program (if any) used during radiated and conducted testing was designed to exercise the various system components in a manner similar to a typical use.

## TEST REPORT

### 3.7 Details of EUT and Description of Accessories

#### Details of EUT:

A battery (provided with the unit) were used to power the device. Their descriptions are listed below.

- (1) A Ni-MH type rechargeable battery (brand: Corun, Model no: BT183342/BT283342, 2.4V 400mAh) (Supplied by Client)
- (2) A Ni-MH type rechargeable battery (brand: Coslight, Model no: BT183342/BT283342, 2.4V 400mAh) (Supplied by Client)
- (3) A Ni-MH type rechargeable battery (brand: GPI, Model no: BT183342/BT283342, 2.4V 400mAh) (Supplied by Client)

#### Description of Accessories:

- (1) Base Unit (Model: DS6251, FCC ID: EW780-1375-00) (Supplied by Client)

### 3.8 Measurement Uncertainty

When determining of the test conclusion, the Measurement Uncertainty of test has been considered. The values of the Measurement uncertainty for radiated emission test, AC line conducted emission test and RF conducted test, frequency stability and timing jitter are  $\pm 5.3\text{dB}$ ,  $\pm 4.2\text{dB}$ ,  $\pm 1\text{dB}$ ,  $\pm 23\text{Hz}$ ,  $0.1\mu\text{s}$  respectively.

Uncertainty and Compliance - Unless the standard specifically states that measured values are to be extended by the measurement uncertainty in determining compliance, all compliance determinations are based on the actual measured value.

**TEST REPORT**

**4.0 MEASUREMENT RESULTS**

4.1 Emissions Outside the Sub-Band, FCC Rule 15.323(d) / RSS-213 Clause 5.8.1:

Emissions outside the sub-band shall be attenuated below a reference power of 112 mW (20.5 dBm) as follows:

1. 30 dB between the band edge and 1.25 MHz above or below the band;
2. 50 dB between 1.25 and 2.5 MHz above or below the band; and
3. 60 dB at 2.5 MHz or greater above or below the band, or shall meet the requirement of FCC Rule 15.319(g) which shall not exceed the limits of FCC Rule 15.209 / RSS-210 Clause 2.5.

Example: Calculation of Limit for emissions between the band edge and 1.25 MHz (1920.000 – 1918.750 MHz)

The emissions shall not exceed the Limit: 20.5 dBm – 30 dB = -9.5 dBm

Measurements are made in accordance with ANSI C63.17 sub-clause 6.1.6.2. Radiated emissions test method is used. Emissions that are directly caused by digital circuits in the transmit path and transmitter portion are measured.

Test setup is shown in section 3.2 Figure 3.2.1

Test Results:

Channel	Carrier Frequency (MHz)	Measured Band (MHz)	Limit (dBm)	Results
Lowest	1921.536	1920.000 - 1918.750	-9.5	Pass
		1918.750 - 1917.500	-29.5	Pass
		0.009 - 1917.500 & 1932.500 - 19300.000	-39.5 / FCC Rule 15.209 / RSS-210 Clause 2.5	Pass
Highest	1928.448	1930.000 - 1931.250	-9.5	Pass
		1931.250 - 1932.500	-29.5	Pass
		0.009 – 1917.500 & 1932.500 - 19300.000	-39.5 / FCC Rule 15.209 / RSS-210 Clause 2.5	Pass

## TEST REPORT

### 4.1.1 Radiated Emissions Configuration Photographs:

Worst Case Radiated Emission  
at

3843.072 MHz

The worst case radiated emission configuration photographs are saved with filename: config photos.pdf

### 4.1.2 Radiated Emissions Data:

Data are included of the worst case configuration (the configuration which resulted in the highest emission levels). A sample calculation, configuration photographs and data tables of the emissions are included. All measurements were performed with peak detection unless otherwise specified.

The data in table 1-3 list the significant emission frequencies, the limit and the margin of compliance.

Judgement:

Passed by 5.5 dB margin

**TEST REPORT**

**RADIATED EMISSIONS DATA**

Mode: Transmission

Table 1

**Pursuant to FCC Part 15 Section 15.323 (d) / RSS-213 Clause 5.8.1 Emissions Requirements**

Lowest Channel

Polarization	Frequency (MHz)	Measured Power (dBm)	Power Limit (dBm)	Margin (dB)
V	1917.274	-56.3	-39.5	-16.8
V	1918.432	-48.5	-29.5	-19.0
V	1919.942	-39.2	-9.5	-29.7
V	3843.072	-45.0	-39.5	-5.5
V	5764.608	-59.0	-39.5	-19.5
V	7686.144	-58.7	-39.5	-19.2
V	9607.680	-56.7	-39.5	-17.2
V	11529.216	-54.3	-39.5	-14.8
V	13450.752	-53.6	-39.5	-14.1

NOTES:

1. Peak detector is used for the emission measurement.
2. All measurements were made at 3 meters.
3. Negative value in the margin column shows emission below limit.

**TEST REPORT**

Mode: Transmission

Table 2

**Pursuant to FCC Part 15 Section 15.323 (d) / RSS-213 Clause 5.8.1 Emissions Requirements**

Highest Channel

Polarization	Frequency (MHz)	Measured Power (dBm)	Power Limit (dBm)	Margin (dB)
V	1930.033	-41.3	-9.5	-31.8
V	1931.362	-51.0	-29.5	-21.5
V	1932.812	-56.7	-39.5	-17.2
V	3856.896	-45.2	-39.5	-5.7
V	5785.344	-59.6	-39.5	-20.1
V	7713.792	-58.3	-39.5	-18.8
V	9642.240	-57.7	-39.5	-18.2
V	11570.688	-54.6	-39.5	-15.1
V	13499.136	-53.5	-39.5	-14.0

NOTES:

1. Peak detector is used for the emission measurement.
2. All measurements were made at 3 meters.
3. Negative value in the margin column shows emission below limit.

**TEST REPORT**

Mode: Talk

Table 3

**Pursuant to FCC Part 15 Section 15.323 (d) / RSS-213 Clause 5.8.1 Emissions Requirements**

Polarization	Frequency (MHz)	Measured Power (dBm)	Power Limit (dBm)	Margin (dB)
V	235.909	-69.6	-39.5	-30.1
V	317.982	-69.5	-39.5	-30.0
V	400.432	-62.8	-39.5	-23.3
V	476.901	-57.9	-39.5	-18.4
V	556.387	-55.3	-39.5	-15.8
V	635.927	-55.6	-39.5	-16.1
V	715.413	-55.9	-39.5	-16.4
V	794.899	-60.6	-39.5	-21.1
V	874.385	-55.9	-39.5	-16.4
V	953.871	-55.2	-39.5	-15.7

NOTES:

1. Peak detector is used for the emission measurement.
2. All measurements were made at 3 meters.
3. Negative value in the margin column shows emission below limit.

## TEST REPORT

### 4.1.3 Field Strength Calculation

The field strength is calculated by adding the reading on the Spectrum Analyzer to the factors associated with preamplifiers (if any), antennas, cables, pulse desensitization and average factors (when specified limit is in average and measurements are made with peak detectors). A sample calculation is included below.

$$FS = RA + AF + CF - AG + PD + AV$$

Where FS = Field Strength in dB $\mu$ V/m

RA = Receiver Amplitude (including preamplifier) in dB $\mu$ V

CF = Cable Attenuation Factor in dB

AF = Antenna Factor in dB

AG = Amplifier Gain in dB

PD = Pulse Desensitization in dB

AV = Average Factor in -dB

In the radiated emission table which follows, the reading shown on the data table may reflect the preamplifier gain. An example of the calculations, where the reading does not reflect the preamplifier gain, follows:

$$FS = RA + AF + CF - AG + PD + AV$$

#### Example

Assume a receiver reading of 62.0 dB $\mu$ V is obtained. The antenna factor of 7.4 dB and cable factor of 1.6 dB is added. The amplifier gain of 29.0 dB is subtracted. The pulse desensitization factor of the spectrum analyzer is 0.0 dB, and the resultant average factor is -10.0 dB. The net field strength for comparison to the appropriate emission limit is 32.0 dB $\mu$ V/m. This value in dB $\mu$ V/m is converted to its corresponding level in  $\mu$ V/m.

$$RA = 62.0 \text{ dB}\mu\text{V}$$

$$AF = 7.4 \text{ dB}$$

$$CF = 1.6 \text{ dB}$$

$$AG = 29.0 \text{ dB}$$

$$PD = 0.0 \text{ dB}$$

$$AV = -10 \text{ dB}$$

$$FS = 62.0 + 7.4 + 1.6 - 29.0 + 0.0 + (-10.0) = 32.0 \text{ dB}\mu\text{V/m}$$

$$\text{Level in } \mu\text{V/m} = \text{Common Antilogarithm } [(32.0 \text{ dB}\mu\text{V/m})/20] = 39.8 \mu\text{V/m}$$

## TEST REPORT

### 4.1.4 Average Factor Calculation and Transmitter ON Time Measurements, FCC Rule 15.35(b, c) / RSS-Gen cl 4.5

- [ ] The EUT antenna output port was connected to the input of the spectrum analyzer. The analyzer center frequency was set to EUT RF channel carrier. The SPAN function on the analyzer was set to ZERO. The transmitter ON time was determined from the resultant time-amplitude display:

Please refer to the attached plots for more details:

The plots of Transmitter ON Time Measurements are as below.

- [ ] Please refer to the attached transmitter timing diagram that are provided by manufacturer
- [ × ] Not applicable - No average factor is required.
- [ ] Please refer to Technical Description (descri.pdf) for more details

## TEST REPORT

### 5.0 EQUIPMENT LIST

#### 1) Radiated Emissions Test

Equipment	EMI Test Receiver	Spectrum Analyzer	BiConiLog Antenna
Registration No.	EW-3156	EW-2253	EW-3061
Manufacturer	ROHDESCHWARZ	R&S	EMCO
Model No.	ESR26	FSP40	3142E
Calibration Date	November 10, 2017	July 24, 2017	November 02, 2017
Calibration Due Date	November 10, 2018	July 24, 2018	November 02, 2018

Equipment	Biconical Antenna	Double Ridged Guide Antenna	Log Periodic Antenna
Registration No.	EW-0571	EW-1133	EW-0447
Manufacturer	EMCO	EMCO	EMCO
Model No.	3104C	3115	3146
Calibration Date	February 27, 2018	May 24, 2017	January 17, 2018
Calibration Due Date	August 27, 2019	November 24, 2018	July 17, 2019

Equipment	Notch Filter (cutoff frequency 1.9GHz to 2.0GHz)	12m Double Shield RF Cable (20MHz to 6GHz)	RF Cable 30cm (1-26)GHz
Registration No.	EW-2360	EW-1852	EW-2268
Manufacturer	MICROWAVE	RADIALL	RADIALL
Model No.	N0319502	N(m)-RG142 - N(m)	SMA(M)/SHF5M/SMA(M)30cm
Calibration Date	January 17, 2018	January 19, 2018	August 23, 2017
Calibration Due Date	January 17, 2019	January 19, 2019	August 23, 2018

Equipment	Pyramidal Horn Antenna (18.0 - 26.5)GHz
Registration No.	EW-0905
Manufacturer	EMCO
Model No.	3160-09
Calibration Date	August 18, 2017
Calibration Due Date	February 18, 2019

#### 3) Conductive Measurement Test

Equipment	Coaxial Directional Coupler	Spectrum Analyzer	Digital Radiocommunication Tester for DECT
Registration No.	EW-2337	EW-2253	EW-2250
Manufacturer	MAGNA	R&S	ROHDESCHWARZ
Model No.	4222-16	FSP40	CMD60
Calibration Date	Nil*	July 24, 2017	January 09, 2018
Calibration Due Date	Nil*	July 24, 2018	January 04, 2019

## TEST REPORT

Equipment	Vector Signal Generator	Temperature & Humidity Chamber	Digital Multimeter
Registration No.	EW-3063	EW-2134	EW-0520
Manufacturer	R&S	GIANT FORCE	FLUKE
Model No.	SMBV100A	GTH-750-40-CP-SD	77-3
Calibration Date	July 27, 2017	August 29, 2017	February 03, 2017
Calibration Due Date	July 27, 2018	September 04, 2018	August 22, 2018

**END OF TEST REPORT**