

TEST REPORT

Report No.: 18030485HKG-001

Application For Original Grant of 47 CFR Part 15 Certification

Single New of RSS-210 Issue 9 Equipment Certification

This report contains the data of Bluetooth 3.0 portion only

FCC ID: EW780-1353-00

IC: 1135B-80135300

Prepared and Checked by:

Approved by:

Signed On File

Josie Yao

Engineer

Jess Tang

Lead Engineer

Date: April 06, 2018

Intertek's standard Terms and Conditions can be obtained at our website <http://www.intertek.com/terms/>.

The test report only allows to be revised within the retention period unless further standard or the requirement was noticed.

This report is for the exclusive use of Intertek's Client and is provided pursuant to the agreement between Intertek and its Client. Intertek's responsibility and liability are limited to the terms and conditions of the agreement. Intertek assumes no liability to any party, other than to the Client in accordance with the agreement, for any loss, expense or damage occasioned by the use of this report. Only the Client is authorized to permit copying or distribution of this report and then only in its entirety. Any use of the Intertek name or one of its marks for the sale or advertisement of the tested material, product or service must first be approved in writing by Intertek. The observations and test results in this report are relevant only to the sample tested. This report by itself does not imply that the material, product, or service is or has ever been under an Intertek certification program.

© 2017 Intertek

TEST REPORT

GENERAL INFORMATION

Grantee:	VTech Telecommunications Ltd.
Grantee Address:	23/F., Tai Ping Industrial Centre, Block 1, 57 Ting Kok Road, Tai Po, Hong Kong.
Contact Person:	Michael Tsui
Tel:	2680 1000
Fax:	2680 5398
e-mail:	michael_tsui@vtech.com
Manufacturer:	VTech (Dongguan) Telecommunications Limited
Manufacturer Address:	VTech Science Park, Xia Ling Bei Management Zone, Liaobu, Dongguan, Guangdong, China.
Brand Name:	vtech
Model:	VSP885G
HVIN:	35-400187BS
PMN:	ErisTerminal SIP Deskset
Type of EUT:	Transceiver
Description of EUT:	SIP Deskset
Serial Number:	N/A
FCC ID / IC:	EW780-1353-00 / 1135B-80135300
Date of Sample Submitted:	March 13, 2018
Date of Test:	March 13, 2018 to April 05, 2018
Report No.:	18030485HKG-001
Report Date:	April 06, 2018
Environmental Conditions:	Temperature: +10 to 40°C Humidity: 10 to 90%

TEST REPORT

SUMMARY OF TEST RESULT

Test Items	FCC Part 15 Section	RSS-210/ RSS-Gen #/ RSS-310^ Section	Results	Details See Section
Antenna Requirement	15.203	8.3 [#]	Pass	2.1
Radiated Emission	15.249(a), 209, & 109	A2.9(a)	Pass	4.2
Radiated Emission on the Bandedge	15.249(d)	A2.9(b)	Pass	4.3
Radiated Emission in Restricted Bands	15.205	2.2	Pass	4.2
AC Power Line Conducted Emission	15.207 & 15.107	8.8 [#]	Pass	4.4

The equipment under test is found to be complying with the following standards:

FCC Part 15, October 1, 2016 Edition
RSS-210 Issue 9, August 2016
RSS-Gen Issue 4, November 2014

Note: 1. The EUT uses a permanently attached antenna which, in accordance to section 15.203, is considered sufficient to comply with the pervisions of this section.
2. Pursuant to FCC part 15 Section 15.215(c), the 20 dB bandwidth of the emission was contained within the frequency band designated (mentioned as above) which the EUT operated. The effects, if any, from frequency sweeping, frequency hopping, other modulation techniques and frequency stability over excepted variations in temperature and supply voltage were considered.

TEST REPORT

TABLE OF CONTENTS

1.0 GENERAL DESCRIPTION 5

1.1 Product Description5

1.2 Related Submittal(s) Grants.....5

1.3 Test Methodology5

1.4 Test Facility5

2.0 SYSTEM TEST CONFIGURATION 6

2.1 Justification6

2.2 EUT Exercising Software6

2.3 Special Accessories.....6

2.4 Measurement Uncertainty6

2.5 Support Equipment List and Description7

3.0 EMISSION RESULTS..... 8

3.1 Field Strength Calculation.....8

3.2 Radiated Emission Configuration Photograph.....9

3.3 Radiated Emission Data9

3.4 Conducted Emission Configuration Photograph9

3.5 Conducted Emission Data9

4.0 EQUIPMENT PHOTOGRAPHS 15

5.0 PRODUCT LABELLING..... 15

6.0 TECHNICAL SPECIFICATIONS 15

7.0 INSTRUCTION MANUAL..... 15

8.0 MISCELLANEOUS INFORMATION 16

8.1 Radiated Emission on the Bandedge.....16

8.2 Discussion of Pulse Desensitization19

8.3 Calculation of Average Factor19

8.4 Emissions Test Procedures20

8.5 Occupied Bandwidth23

9.0 CONFIDENTIALITY REQUEST 24

10.0 EQUIPMENT LIST 24

TEST REPORT

1.0 GENERAL DESCRIPTION

1.1 Product Description

The Equipment Under Test (EUT) is an VoIP phone which can support Bluetooth 3.0 and 4.0. For Bluetooth 3.0, it operates at the frequency range of 2402-2480MHz with 1 MHz channel spacing. For Bluetooth 4.0, it operates at the frequency range of 2402-2480MHz with 2 MHz channel spacing. The EUT is powered by 100-240VAC adaptor or PoE.

Antenna Type: Internal, Integral

For electronic filing, the brief circuit description is saved with filename: descri.pdf.

1.2 Related Submittal(s) Grants

This is a single application for certification of a transceiver.

1.3 Test Methodology

Both AC mains line-conducted and radiated emission measurements were performed according to the procedures in ANSI C63.10 (2013). All radiated measurements were performed in an 3m Chamber. Preliminary scans were performed in the 3m Chamber only to determine worst case modes. All radiated tests were performed at an antenna to EUT distance of 3 meters, unless stated otherwise in the “**Justification Section**” of this Application.

1.4 Test Facility

The 3m Chamber and conducted measurement facility used to collect the radiated data is located at Workshop No. 3, G/F., World-Wide Industrial Centre, 43-47 Shan Mei Street, Fo Tan, Sha Tin, N.T., Hong Kong. This test facility and site measurement data have been placed on file with the FCC and IC No. 2042V-1.

TEST REPORT

2.0 SYSTEM TEST CONFIGURATION

2.1 Justification

The system was configured for testing in a typical fashion (as a customer would normally use it), and in the confines as outlined in ANSI C63.10 (2013).

The device was powered by 100-240VAC adaptor or PoE.

For maximizing emissions, the EUT was rotated through 360°, the antenna height was varied from 1 meter to 4 meters above the ground plane, and the antenna polarization was changed. This step by step procedure for maximizing emissions led to the data reported in Exhibit 3.0.

The rear of unit shall be flushed with the rear of the table.

The equipment under test (EUT) was configured for testing in a typical fashion (as a customer would normally use it). The EUT was mounted to a plastic stand if necessary and placed on the wooden turntable, which enabled the engineer to maximize emissions through its placement in the three orthogonal axes.

All relevant operation modes and power sources have been tested, and the worst case data was included in this report.

2.2 EUT Exercising Software

The EUT exercise program used during radiated and conducted testing was designed to exercise the various system components in a manner similar to a typical use.

2.3 Special Accessories

There are no special accessories necessary for compliance of this product.

2.4 Measurement Uncertainty

When determining of the test conclusion, the Measurement Uncertainty of test has been considered.

Uncertainty and Compliance - Unless the standard specifically states that measured values are to be extended by the measurement uncertainty in determining compliance, all compliance determinations are based on the actual measured value.

TEST REPORT

2.5 Support Equipment List and Description

An AC adaptor (provided with the unit) was used to power the device. Their description are listed below.

- (1) An AC adaptor with ferrite (Brand: SIL, Input: 100-240V, 50/60Hz, 300mA to Output: 5V, 2000mA, Model: SSA-050200US) (Supplied by Client)
- (2) An AC adaptor (Brand: PHIHONG, Input: 100-240V, 50/60Hz, 300mA to Output: 5V, 2000mA, Model: PSM10R-050) (Supplied by Client)
- (3) An AC adaptor (Brand: TenPao, Input: 100-240V, 50/60Hz, 500mA to Output: 5V, 2000mA, Model: S018BAM0500200) (Supplied by Client)

Other support equipment:

- (1) Expansion Module (Brand: Snom, Model: D3, PN: 00004327) (Supplied by Client)
- (2) Notebook (Brand: HP) (Supplied by Intertek)
- (3) LAN Cable x2 with the length of 1m (Supplied by Intertek)
- (4) Headset (Brand: Snom, Model: A100M, PN: 00004341) (Supplied by Client)
- (5) EHS Advanced V2.0 (Brand: snom, Model: EHS Advanced V2.0, PN: 00002362) (Supplied by Client)
- (6) PoE (Power over Ethernet), Brand: TP-LINK, Model: TL-POE150S with Adaptor (Model: MU24-1480050-B2, Input: 100-240V, 50/60Hz, 1.0A; Output: 48V, 0.5A) (Supplied by Intertek)

TEST REPORT

3.0 EMISSION RESULTS

Data is included of the worst case configuration (the configuration which resulted in the highest emission levels). A sample calculation, configuration photographs and data tables of the emissions are included.

3.1 Field Strength Calculation

The field strength is calculated by adding the Antenna Factor and Cable Factor, and subtracting the Amplifier Gain (if any), Average Factor (optional) from the measured reading. The basic equation with a sample calculation is as follows:

$$FS = RA + AF + CF - AG - AV$$

where FS = Field Strength in dB μ V/m

RA = Receiver Amplitude (including preamplifier) in dB μ V

CF = Cable Attenuation Factor in dB

AF = Antenna Factor in dB

AG = Amplifier Gain in dB

AV = Average Factor in dB

In the following table(s), the reading shown on the data table reflects the preamplifier gain. An example for the calculations in the following table is as follows:

$$FS = RR + LF$$

where

FS = Field Strength in dB μ V/m

RR = RA - AG - AV in dB μ V

LF = CF + AF in dB

Assume a receiver reading of 52.0 dB μ V is obtained. The antenna factor of 7.4 dB and cable factor of 1.6 dB are added. The amplifier gain of 29 dB and average factor of 5 dB are subtracted, giving a field strength of 32 dB μ V/m. This value in dB μ V/m was converted to its corresponding level in μ V/m.

$$RA = 52.0 \text{ dB}\mu\text{V/m}$$

$$AF = 7.4 \text{ dB}$$

$$CF = 1.6 \text{ dB}$$

$$AG = 29.0 \text{ dB}$$

$$AV = 5.0 \text{ dB}$$

$$FS = RR + LF$$

$$FS = 18 + 9 = 27 \text{ dB}\mu\text{V/m}$$

$$RR = 18.0 \text{ dB}\mu\text{V}$$

$$LF = 9.0 \text{ dB}$$

$$\text{Level in } \mu\text{V/m} = \text{Common Antilogarithm } [(27 \text{ dB}\mu\text{V/m})/20] = 22.4 \mu\text{V/m}$$

TEST REPORT

3.2 Radiated Emission Configuration Photograph

The worst case in radiated emission was found at 35.725 MHz

For electronic filing, the worst case radiated emission configuration photographs are saved with filename: radiated photos.pdf.

3.3 Radiated Emission Data

The data on the following page lists the significant emission frequencies, the limit and the margin of compliance. Numbers with a minus sign are below the limit.

Judgment: Passed by 1.7 dB

3.4 Conducted Emission Configuration Photograph

The worst case in line-conducted emission was found at 2.571 MHz

For electronic filing, the worst case line-conducted configuration photographs are saved with filename: conducted photo.pdf.

3.5 Conducted Emission Data

For electronic filing, the graph and data table of conducted emission is saved with filename: conducted.pdf.

Judgment: Pass by 6.01 dB

TEST REPORT

CONDUCTED EMISSION

Model: VSP885G

Date of Test: April 09, 2018

Worst-Case Operating Mode: Transmitting with adaptor SIL

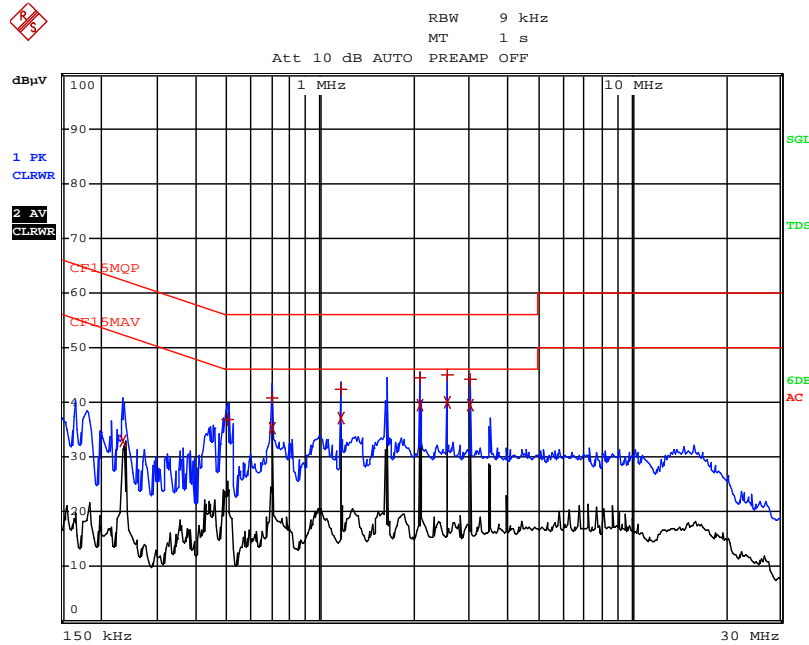

EDIT PEAK LIST (Final Measurement Results)				
TRACE	FREQUENCY	LEVEL dBµV		DELTA LIMIT dB
Trace1:	CF15MQP			
Trace2:	CF15MAV			
Trace3:	---			
2	CISPR Average 235.5 kHz	32.93	N	-19.32
1	Quasi Peak 505.5 kHz	36.92	N	-19.07
1	Quasi Peak 699 kHz	40.78	N	-15.21
2	CISPR Average 699 kHz	35.20	N	-10.79
1	Quasi Peak 1.167 MHz	42.43	N	-13.56
2	CISPR Average 1.167 MHz	37.13	N	-8.86
1	Quasi Peak 2.103 MHz	44.54	N	-11.45
2	CISPR Average 2.103 MHz	39.42	N	-6.57
1	Quasi Peak 2.571 MHz	44.92	N	-11.07
2	CISPR Average 2.571 MHz	39.98	N	-6.01
1	Quasi Peak 3.039 MHz	44.27	N	-11.72
2	CISPR Average 3.039 MHz	39.59	N	-6.40

Note: Measurement Uncertainty is ±4.2dB at a level of confidence of 95%.

TEST REPORT

RADIATED EMISSIONS

Model: VSP885G

Date of Test: April 09, 2018

Worst-Case Operating Mode: Transmitting

Table 1
Pursuant to FCC Part 15 Section 15.249 / RSS-210 B10.0 Requirement

Lowest Channel

Polarization	Frequency (MHz)	Reading (dB μ V)	Pre-Amp Gain (dB)	Antenna Factor (dB)	Net at 3m - Peak (dB μ V/m)	Average Factor (dB)	Calculated at 3m (dB μ V/m)	Average Limit at 3m (dB μ V/m)	Margin (dB)
H	2402.000	104.0	33	29.4	100.4	24	76.4	94.0	-17.6
H	4804.000	44.5	33	34.9	46.4	24	22.4	54.0	-31.6
V	7206.000	43.2	33	37.9	48.1	24	24.1	54.0	-29.9
V	9608.000	43.1	33	40.4	50.5	24	26.5	54.0	-27.5
H	12010.000	45.4	33	40.5	52.9	24	28.9	54.0	-25.1
V	14412.000	45.6	33	40.0	52.6	24	28.6	54.0	-25.4

Polarization	Frequency (MHz)	Reading (dB μ V)	Pre-Amp Gain (dB)	Antenna Factor (dB)	Net at 3m - Peak (dB μ V/m)	Peak Limit at 3m (dB μ V/m)	Margin (dB)
H	2402.000	104.0	33	29.4	100.4	114.0	-13.6
H	4804.000	44.5	33	34.9	46.4	74.0	-27.6
V	7206.000	43.2	33	37.9	48.1	74.0	-25.9
V	9608.000	43.1	33	40.4	50.5	74.0	-23.5
H	12010.000	45.4	33	40.5	52.9	74.0	-21.1
V	14412.000	45.6	33	40.0	52.6	74.0	-21.4

- NOTES:
1. Peak Detector Data unless otherwise stated.
 2. All measurements were made at 3 meters. Harmonic emissions not detected at the 3-meter distances were measured at 0.3-meter and an inverse proportional extrapolation was performed to compare the signal level to the 3-meter limit. No other harmonic emissions than those reported were detected at a test distance of 0.3-meter.
 3. Negative sign in the column shows value below limit.
 4. Horn antenna is used for the emission over 1000MHz.
 5. Emission within the restricted band meets the requirement of FCC Part 15 Section 15.205 / RSS-210 4.1.

TEST REPORT

Model: VSP885G
Date of Test: April 09, 2018
Worst-Case Operating Mode: Transmitting

**Table 2
Pursuant to FCC Part 15 Section 15.249 / RSS-210 B10.0 Requirement**

Middle Channel

Polarization	Frequency (MHz)	Reading (dBμV)	Pre-Amp Gain (dB)	Antenna Factor (dB)	Net at 3m - Peak (dBμV/m)	Average Factor (dB)	Calculated at 3m (dBμV/m)	Average Limit at 3m (dBμV/m)	Margin (dB)
H	2440.000	103.4	33	29.4	99.8	24	75.8	94.0	-18.2
H	4880.000	44.3	33	34.9	46.2	24	22.2	54.0	-31.8
V	7320.000	43.0	33	37.9	47.9	24	23.9	54.0	-30.1
V	9760.000	43.3	33	40.4	50.7	24	26.7	54.0	-27.3
H	12200.000	45.6	33	40.5	53.1	24	29.1	54.0	-24.9
V	14640.000	47.7	33	38.4	53.1	24	29.1	54.0	-24.9

Polarization	Frequency (MHz)	Reading (dBμV)	Pre-Amp Gain (dB)	Antenna Factor (dB)	Net at 3m - Peak (dBμV/m)	Peak Limit at 3m (dBμV/m)	Margin (dB)
H	2440.000	103.4	33	29.4	99.8	114.0	-14.2
H	4880.000	44.3	33	34.9	46.2	74.0	-27.8
V	7320.000	43.0	33	37.9	47.9	74.0	-26.1
V	9760.000	43.3	33	40.4	50.7	74.0	-23.3
H	12200.000	45.6	33	40.5	53.1	74.0	-20.9
V	14640.000	47.7	33	38.4	53.1	74.0	-20.9

- NOTES:
1. Peak Detector Data unless otherwise stated.
 2. All measurements were made at 3 meters. Harmonic emissions not detected at the 3-meter distances were measured at 0.3-meter and an inverse proportional extrapolation was performed to compare the signal level to the 3-meter limit. No other harmonic emissions than those reported were detected at a test distance of 0.3-meter.
 3. Negative sign in the column shows value below limit.
 4. Horn antenna is used for the emission over 1000MHz.
 5. Emission within the restricted band meets the requirement of FCC Part 15 Section 15.205 / RSS-210 4.1.
 6. Measurement Uncertainty is ±5.3dB at a level of confidence of 95%.

TEST REPORT

Model: VSP885G
Date of Test: April 09, 2018
Worst-Case Operating Mode: Transmitting

**Table 3
Pursuant to FCC Part 15 Section 15.249 / RSS-210 B10.0 Requirement**

Highest Channel

Polarization	Frequency (MHz)	Reading (dBμV)	Pre-Amp Gain (dB)	Antenna Factor (dB)	Net at 3m - Peak (dBμV/m)	Average Factor (dB)	Calculated at 3m (dBμV/m)	Average Limit at 3m (dBμV/m)	Margin (dB)
H	2480.000	102.1	33	29.4	98.5	24	74.5	94.0	-19.5
H	4960.000	44.1	33	34.9	46.0	24	22.0	54.0	-32.0
V	7440.000	43.4	33	37.9	48.3	24	24.3	54.0	-29.7
V	9920.000	43.0	33	40.4	50.4	24	26.4	54.0	-27.6
H	12400.000	45.4	33	40.5	52.9	24	28.9	54.0	-25.1
V	14880.000	47.4	33	38.4	52.8	24	28.8	54.0	-25.2

Polarization	Frequency (MHz)	Reading (dBμV)	Pre-Amp Gain (dB)	Antenna Factor (dB)	Net at 3m - Peak (dBμV/m)	Peak Limit at 3m (dBμV/m)	Margin (dB)
H	2480.000	102.1	33	29.4	98.5	114.0	-15.5
H	4960.000	44.1	33	34.9	46.0	74.0	-28.0
V	7440.000	43.4	33	37.9	48.3	74.0	-25.7
V	9920.000	43.0	33	40.4	50.4	74.0	-23.6
H	12400.000	45.4	33	40.5	52.9	74.0	-21.1
V	14880.000	47.4	33	38.4	52.8	74.0	-21.2

- NOTES:
1. Peak Detector Data unless otherwise stated.
 2. All measurements were made at 3 meters. Harmonic emissions not detected at the 3-meter distances were measured at 0.3-meter and an inverse proportional extrapolation was performed to compare the signal level to the 3-meter limit. No other harmonic emissions than those reported were detected at a test distance of 0.3-meter.
 3. Negative sign in the column shows value below limit.
 4. Horn antenna is used for the emission over 1000MHz.
 5. Emission within the restricted band meets the requirement of FCC Part 15 Section 15.205 / RSS-210 4.1.
 6. Measurement Uncertainty is ±5.3dB at a level of confidence of 95%.

TEST REPORT

Model: VSP885G

Date of Test: April 09, 2018

Worst-Case Operating Mode: Speakerphone talk with PoE

Table 4
Pursuant to FCC Part 15 Section 15.209 / RSS-210 4.4 Requirement

Polarization	Frequency (MHz)	Reading (dBμV)	Pre-amp (dB)	Antenna Factor (dB)	Net at 3m (dBμV/m)	Limit at 3m (dBμV/m)	Margin (dB)
V	35.725	44.3	16	10.0	38.3	40.0	-1.7
V	39.679	44.2	16	10.0	38.2	40.0	-1.8
V	41.575	43.2	16	10.0	37.2	40.0	-2.8
V	45.095	43.8	16	10.0	37.8	40.0	-2.2
V	57.175	40.9	16	11.0	35.9	40.0	-4.1
V	82.687	46.1	16	7.0	37.1	40.0	-2.9
V	220.595	37.7	16	17.0	38.7	46.0	-7.3
V	666.712	25.8	16	29.0	38.8	46.0	-7.2

- NOTES:
1. Peak Detector Data unless otherwise stated.
 2. All measurements were made at 3 meters. Harmonic emissions not detected at the 3-meter distances were measured at 0.3-meter and an inverse proportional extrapolation was performed to compare the signal level to the 3-meter limit. No other harmonic emissions than those reported were detected at a test distance of 0.3-meter.
 3. Negative sign in the column shows value below limit.
 4. Horn antenna is used for the emission over 1000MHz.
 5. Emission within the restricted band meets the requirement of FCC Part 15 Section 15.205 / RSS-210 4.1.
 6. Measurement Uncertainty is ±5.3dB at a level of confidence of 95%.

TEST REPORT

4.0 EQUIPMENT PHOTOGRAPHS

For electronic filing, the photographs are saved with filename: external photos.pdf and internal photos.pdf.

5.0 PRODUCT LABELLING

For electronics filing, the FCC ID label artwork and the label location are saved with filename: label.pdf.

6.0 TECHNICAL SPECIFICATIONS

For electronic filing, the block diagram and schematic of the tested EUT are saved with filename: block.pdf and circuit.pdf respectively.

7.0 INSTRUCTION MANUAL

For electronic filing, a preliminary copy of the Instruction Manual is saved with filename: manual.pdf.

This manual will be provided to the end-user with each unit sold/leased in the United States and Canada.

TEST REPORT

8.0 MISCELLANEOUS INFORMATION

The miscellaneous information includes details of the test procedure and measured bandwidth / calculation of factor such as pulse desensitization and averaging factor (calculation and timing diagram).

8.1 Radiated Emission on the Bandedge

From the following plots, they show that the fundamental emissions are confined in the specified band (2400MHz to 2483.5MHz). In case of the fundamental emissions are within two standard bandwidths from the bandedge, the delta measurement technique is used for determining bandedge compliance. Standard bandwidth is the bandwidth specified by ANSI C63.10 (2013) for frequency being measured.

Emissions radiated outside of the specified frequency bands, except harmonics, are attenuated by 50dB below the level of the fundamental or to the general radiated emissions limits in Section 15.209 / RSS-210 4.4, whichever is the lesser attenuation, which meet the requirement of part 15.249(d) / RSS-210 B.10.

Measurement Uncertainty is ± 1.0 dB at a level of confidence of 95%.

TEST REPORT

PEAK MEASUREMENT

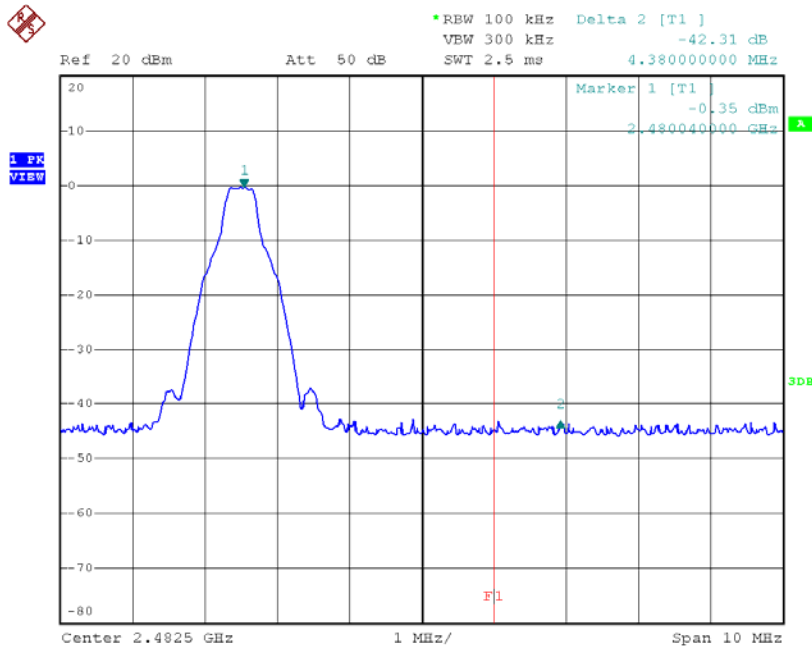
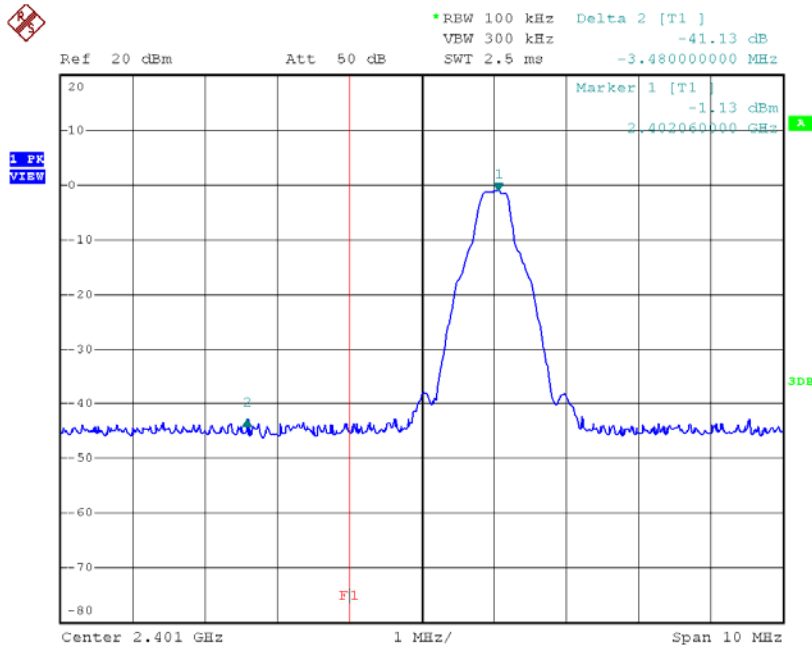

TEST REPORT

PEAK MEASUREMENT

Bandedge compliance is determined by applying marker-delta method, i.e. (Bandedge Plot).

Lower bandedge

Peak Resultant field strength = Fundamental emissions (peak value) – delta from the plot

=100.4 dB μ V/m – 41.1 dB

=59.3 dB μ V/m

Average Resultant field strength = Fundamental emissions (average value) – delta from the plot

=76.4 dB μ V/m – 41.1 dB

=35.3 dB μ V/m

Upper bandedge

Peak Resultant field strength = Fundamental emissions (peak value) – delta from the plot

=98.5 dB μ V/m – 42.3 dB

=56.2 dB μ V/m

Average Resultant field strength = Fundamental emissions (average value) – delta from the plot

=74.5 dB μ V/m – 42.3 dB

=32.2 dB μ V/m

The resultant field strength meets the general radiated emission limit in Section 15.209 / RSS-210 4.4, which does not exceed 74 dB μ V/m (Peak Limit) and 54 dB μ V/m (Average Limit).

TEST REPORT

8.2 Discussion of Pulse Desensitization

Determination of pulse desensitization was made according to *Hewlett Packard Application Note 150-2, Spectrum Analysis... Pulsed RF*. The effective period (T_{eff}) was $625\mu s$. With the resolution bandwidth 1MHz and spectrum analyzer IF bandwidth 3dB, the pulse desensitization factor was 0dB.

8.3 Calculation of Average Factor

Based on the Bluetooth Specification Version 3.0 + EDR, the transmitter ON time for each timeslot of Bluetooth is $625\mu s$. DH5 has the maximum duty cycle, which consists of 5 continuous Tx slots and 1 Rx slot. Therefore one hopset take $(5+1) \times 625\mu s = 3.75ms$. For one period for a pseudo-random hopping through at least 20 RF channels in adaptive mode (worse case), it take: $20 \times 3.75ms = 75ms$.

The dwell time for DH5 is $5 \times 625\mu s = 3.125ms$.

For the worst case calculation, there are two transmissions might occur in 100ms. Therefore,

$$\begin{aligned} \text{Duty Cycle (DC)} &= \text{Maximum On time in } 100ms/100ms \\ &= 3.125ms \times 2/100ms \\ &= 0.0625 \end{aligned}$$

$$\begin{aligned} \text{Average Factor (AF) of Bluetooth in dB} &= 20 \log_{10} (0.0625) \\ &= -24 \text{ dB} \end{aligned}$$

TEST REPORT

8.4 Emissions Test Procedures

The following is a description of the test procedure used by Intertek Testing Services Hong Kong Ltd. in the measurements of transmitter operating under the Part 15, Subpart C rules.

The transmitting equipment under test (EUT) is placed on a wooden turntable which is four feet in diameter and approximately 0.8m in height above the ground plane for emission measurement at or below 1GHz and 1.5m in height above the ground plane for emission measurement above 1GHz. During the radiated emissions test, the turntable is rotated and any cables leaving the EUT are manipulated to find the configuration resulting in maximum emissions. The EUT is adjusted through all three orthogonal axis to obtain maximum emission levels. The antenna height and polarization are also varied during the testing to search for maximum signal levels. The height of the antenna is varied from one to four meters.

Detector function for radiated emissions is in peak mode. Average readings, when required, are taken by measuring the duty cycle of the equipment under test and subtracting the corresponding amount in dB from the measured peak readings. A detailed description for the calculation of the average factor can be found in Exhibit 8.3.

The frequency range scanned is from the lowest radio frequency signal generated in the device which is greater than 9 kHz to the tenth harmonic of the highest fundamental frequency or 40 GHz, whichever is lower. For line conducted emissions, the range scanned is 150 kHz to 30 MHz.

TEST REPORT

8.4 Emissions Test Procedures (cont'd)

The EUT is warmed up for 15 minutes prior to the test.

AC power to the unit is varied from 85% to 115% nominal and variation in the fundamental emission field strength is recorded. If battery powered, a new, fully charged battery is used.

Conducted measurements were made as described in ANSI C63.10 (2013).

The IF bandwidth used for measurement of radiated signal strength was 100 kHz or greater when frequency is below 1000 MHz. Where pulsed transmissions of short enough pulse duration warrant, a greater bandwidth is selected according to the recommendations of Hewlett Packard Application Note 150-2. A discussion of whether pulse desensitivity is applicable to this unit is included in this report (See Exhibit 8.1). Above 1000 MHz, a resolution bandwidth of 3 MHz is used.

Transmitter measurements are normally conducted at a measurement distance of three meters. However, to assure low enough noise floor in the forbidden bands and above 1 GHz, signals are acquired at a distance of one meter or less. All measurements are extrapolated to three meters using inverse scaling, unless otherwise reported. Measurements taken at a closer distance are so marked.

TEST REPORT

8.4.1 Radiated Emission Test Setup

The figure below shows the test setup, which is utilized to make these measurements.

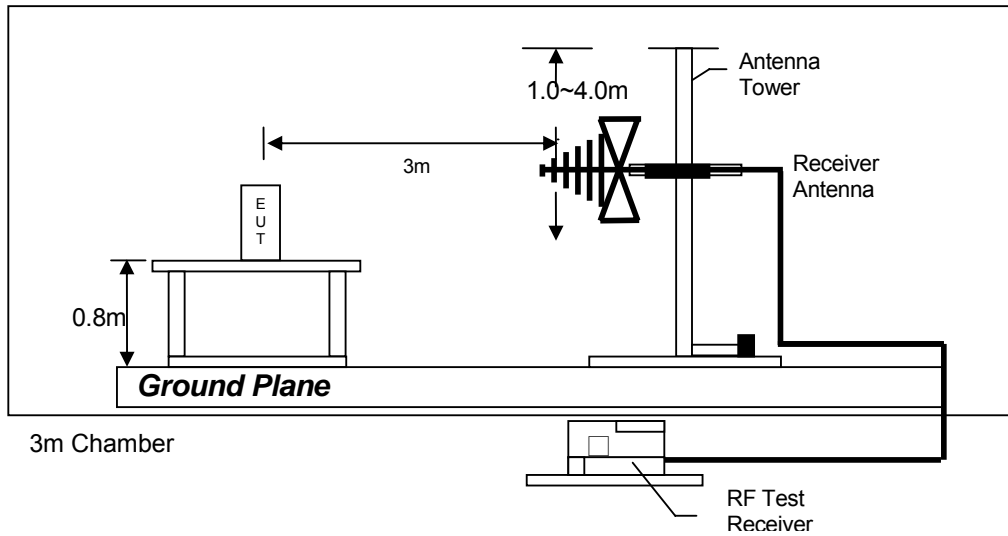

Test setup of radiated emissions up to 1GHz

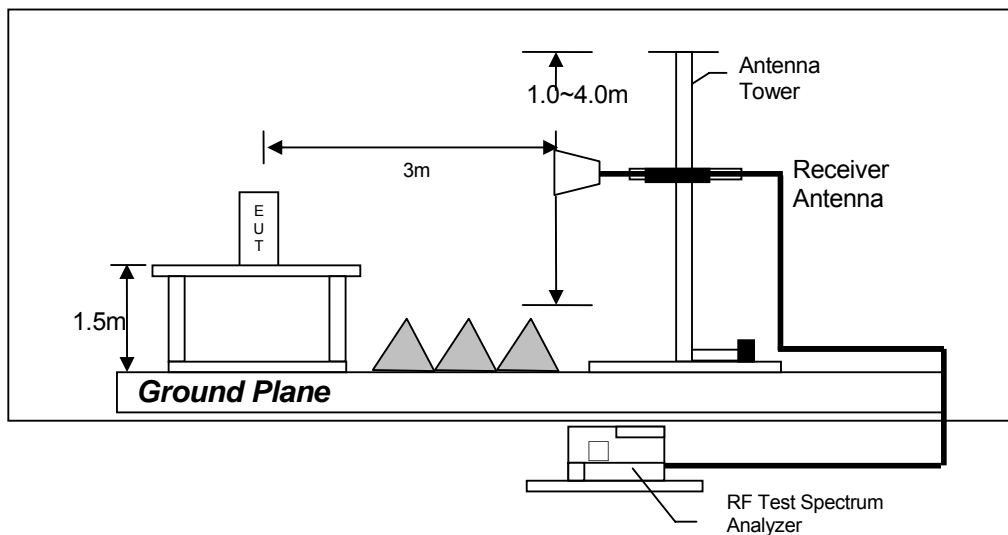

Test setup of radiated emissions above 1GHz

TEST REPORT

8.5 Occupied Bandwidth

Occupied Bandwidth Results:

Occupied Bandwidth (kHz)	
Low Channel: 2402	900
Middle Channel: 2441	900
High Channel: 2480	890

The worst case is shown as below

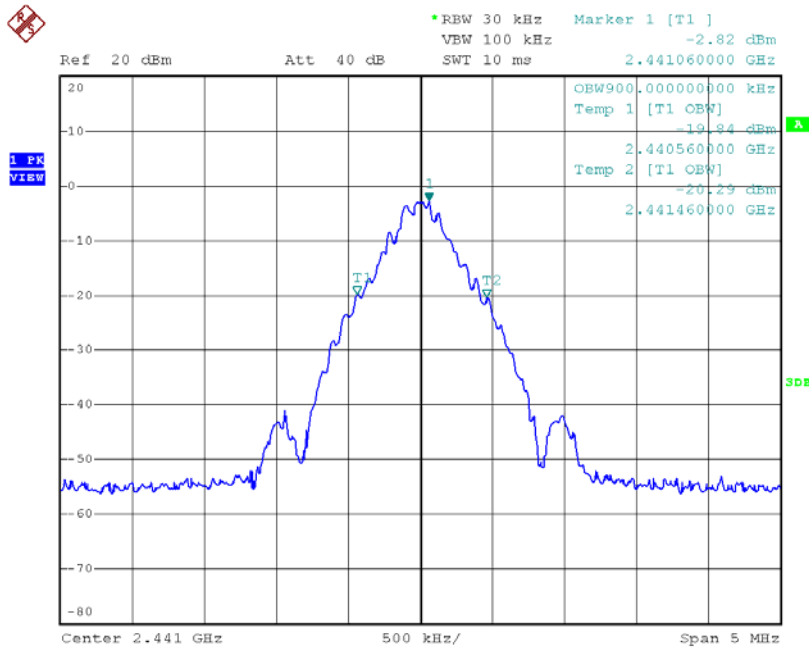

TEST REPORT

9.0 CONFIDENTIALITY REQUEST

For electronic filing, a preliminary copy of the confidentiality request is saved with filename: request.pdf.

10.0 EQUIPMENT LIST

1) Radiated Emissions Test

Equipment	EMI Test Receiver	Spectrum Analyzer	BiConiLog Antenna
Registration No.	EW-3156	EW-2253	EW-3061
Manufacturer	ROHDESCHWARZ	ROHDESCHWARZ	EMCO
Model No.	ESR26	FSP40	3142E
Calibration Date	November 10, 2017	July 24, 2017	November 02, 2017
Calibration Due Date	November 10, 2018	July 24, 2018	November 02, 2018

Equipment	Double Ridged Guide Antenna	Pyramidal Horn Antenna
Registration No.	EW-1133	EW-0905
Manufacturer	EMCO	EMCO
Model No.	3115	3160-09
Calibration Date	May 24, 2017	August 18, 2017
Calibration Due Date	November 24, 2018	February 18, 2019

Equipment	RF Cable (20MHz - 6GHz)	RF Cable (up to 40GHz)	Notch Filter (cutoff frequency 2.4GHz to 2.5GHz)
Registration No.	EW-2505	EW-3155	EW-3155
Manufacturer	RADIALL	N/A	MICROTRONICS
Model No.	nm / br5d / sma 14m	1-40 GHz	BRM50701-02
Calibration Date	October 30, 2017	January 29, 2018	May 26, 2017
Calibration Due Date	October 30, 2018	January 29, 2019	May 26, 2018

2) Conducted Emissions Test

Equipment	EMI Test Receiver	LISN	Pulse Limiter
Registration No.	EW-2500	EW-0192	EW-0700
Manufacturer	R&S	R&S	ROHDESCHWARZ
Model No.	ESCI	ESH3-Z5	ESH3-Z2
Calibration Date	October 13, 2017	October 27, 2017	September 07, 2017
Calibration Due Date	October 13, 2018	August 25, 2018	March 07, 2019

Equipment	RF Cable
Registration No.	EW-2451
Manufacturer	RADIALL
Model No.	bnc m st / 142 / bnc m st 80cm
Calibration Date	August 08, 2017
Calibration Due Date	August 08, 2018

3) Bandedge Measurement

Equipment	Spectrum Analyzer
Registration No.	EW-2329
Manufacturer	R&S
Model No.	FSP3
Calibration Date	September 28, 2017
Calibration Due Date	September 28, 2018

END OF TEST REPORT