

TEST REPORT

Report No.: 17060694HKG-002

Application For Class II Permissive Change of 47 CFR Part 15 Certification

1.9GHz Digital Modulation Cordless Phone with Caller ID, Speakerphone, Digital Answering Machine and Bluetooth - Base Unit Bluetooth Portion

FCC ID: EW780-0381-00

PREPARED AND CHECKED BY:

APPROVED BY:

Signed On File
Leung Chiu Kuen, Stanley
Engineer

Jess Tang
Lead Engineer
Date: June 28, 2017

Intertek's standard Terms and Conditions can be obtained at our website <http://www.intertek.com/terms/>.

The test report only allows to be revised within the retention period unless further standard or the requirement was noticed

This report is for the exclusive use of Intertek's Client and is provided pursuant to the agreement between Intertek and its Client. Intertek's responsibility and liability are limited to the terms and conditions of the agreement. Intertek assumes no liability to any party, other than to the Client in accordance with the agreement, for any loss, expense or damage occasioned by the use of this report. Only the Client is authorized to permit copying or distribution of this report and then only in its entirety. Any use of the Intertek name or one of its marks for the sale or advertisement of the tested material, product or service must first be approved in writing by Intertek. The observations and test results in this report are relevant only to the sample tested. This report by itself does not imply that the material, product, or service is or has ever been under an Intertek certification program.

© 2017 Intertek

TEST REPORT

GENERAL INFORMATION

Grantee:	VTech Telecommunications Ltd.
Grantee Address:	23/F., Tai Ping Industrial Centre, Block 1, 57 Ting Kok Road, Tai Po, Hong Kong.
FCC Specification Standard:	FCC Part 15, October 1, 2015 Edition
FCC ID:	EW780-0381-00
FCC Model(s):	TL96457, TL96547, TL96XY7, TL96457 BS, TL96547 BS, TL96XY7 BS
Type of EUT:	Transceiver
Description of EUT:	1.9GHz Digital Modulation Cordless Phone with Caller ID, Speakerphone, Digital Answering Machine and Bluetooth - Base Unit Bluetooth Portion
Serial Number:	N/A
Sample Receipt Date:	June 09, 2017
Date of Test:	June 12- June 20, 2017
Report Date:	June 28, 2017
Environmental Conditions:	Temperature: +10 to 40°C Humidity: 10 to 90%

TEST REPORT

TABLE OF CONTENTS

1.0 Test Results Summary & Statement of Compliance..... 4
 1.1 Summary of Test Results 4
 1.2 Statement of Compliance..... 4

2.0 General Description..... 5
 2.1 Product Description 5
 2.2 Test Methodology..... 5
 2.3 Test Facility 5

3.0 System Test Configuration..... 6
 3.1 Justification 6
 3.2 EUT Exercising Software..... 7
 3.3 Radiated Emission Test Setup 8
 3.4 Conducted Emission Test Setup 9
 3.5 Details of EUT and Description of Accessories..... 10
 3.6 Measurement Uncertainty..... 10

4.0 Test Results..... 11
 4.1 Field Strength Calculation 11
 4.2 Radiated Emissions 12
 4.2.1 Radiated Emission Configuration Photograph..... 12
 4.2.2 Radiated Emission Data..... 12
 4.3 AC Power Line Conducted Emission 20
 4.3.1 AC Power Line Conducted Emission Configuration Photograph 20
 4.3.2 AC Power Line Conducted Emission Data..... 20

5.0 Equipment List..... 23

TEST REPORT

EXHIBIT 1 TEST RESULTS SUMMARY & STATEMENT OF COMPLIANCE

1.0 Test Results Summary & Statement of Compliance

1.1 Summary of Test Results

TEST ITEMS	FCC PART 15 SECTION	RESULTS	DETAILS SEE SECTION
Antenna Requirement	15.203	Pass	2.1
Security Code Information	15.214(d)	Pass	2.1
Radiated Emission	15.249(a), 209, & 109	Pass	4.2
Radiated Emission on the Bandedge	15.249(d)	Pass	4.3
Radiated Emission in Restricted Bands	15.205	Pass	4.2
AC Power Line Conducted Emission	15.207 & 15.107	Pass	4.4

Note: Pursuant to FCC Part 15 Section 15.215(c), the 20dB bandwidth of the emission was contained within the frequency band designated (mentioned as above) which the EUT operated. The effects, if any, from frequency sweeping, frequency hopping, other modulation techniques and frequency stability over expected variations in temperature and supply voltage were considered.

1.2 Statement of Compliance

The equipment under test is found to be complying with the following standards:

FCC Part 15, October 1, 2015 Edition

TEST REPORT**EXHIBIT 2 GENERAL DESCRIPTION****2.0 General Description****2.1 Product Description**

The TL96457 is a 1.9GHz Digital Modulation Cordless Phone with Caller ID, Speakerphone, Digital Answering Machine and Bluetooth - Base Unit Bluetooth Portion. Only Base Unit has Bluetooth feature and it operates at frequency range of 2402MHz to 2480MHz. The Base Unit is powered by an adaptor 100-120VAC 60Hz 200mA to 6VDC 600mA. With Bluetooth device registered and enabled, the Base Unit allows user uses the cordless handset to make or receive cellular phone calls via the cellular network. Two Bluetooth devices can be connected at the same time.

The Bluetooth antenna used in base unit is integral, and the test sample is a prototype.

Base Unit of Model(s): TL96547, TL96XY7, TL96457 BS, TL96547 BS, TL96XY7 BS are the same as the Model: TL96457 in electrical designs including software & firmware, PCB layout and construction design/physical design/enclosure. The only differences between these models are color, model number, package type and number of handsets and Chargers to be sold for marketing purpose. Suffix (X, Y) indicates alphanumeric character is representing different number of handset(s) and charger(s) and different package type or color of enclosure.

The circuit description is saved with filename: descri.pdf.

Connection between the device and the telephone network is accomplished through the use of USOC RJ11C in the 2-wire loop calling central office line.

2.2 Test Methodology

Both AC power line-conducted and radiated emission measurements were performed according to the procedures in ANSI C63.10 (2013). Preliminary radiated scans and all radiated measurements were performed in Radiated Emission Test Sites. All Radiated tests were performed at an antenna to EUT distance of 3 meters, unless stated otherwise in the "**Justification Section**" of this Application.

2.2 Purpose of Change

The purpose of change is saved with filename: product change.pdf

2.3 Test Facility

The radiated emission test sites and conducted measurement facility used to collect the radiated data and conducted data are at Workshop No. 3, G/F., World-Wide Industrial Centre, 43-47 Shan Mei Street, Fo Tan, Sha Tin, N.T., Hong Kong. This test facility and site measurement data have been fully placed on file with the FCC.

TEST REPORT

EXHIBIT 3 SYSTEM TEST CONFIGURATION

3.0 System Test Configuration

3.1 Justification

For radiated emissions testing, the equipment under test (EUT) was setup to transmit continuously mode to simplify the measurement methodology. Care was taken to ensure proper power supply voltages during testing. During testing, all cables (if any) were manipulated to produce worst case emissions.

The Base Unit was powered by 100-120VAC 60Hz 200mA to 6VDC 600mA adaptor.

For the measurements, the EUT was attached to a plastic stand if necessary and placed on the wooden turntable which is four feet in diameter and approximately 0.8m in height above the ground plane for emission measurement at or below 1GHz and 1.5m in height above the ground plane for emission measurement above 1GHz. If the base unit attached to peripherals, they were connected and operational to simulate typical use. The handset was remotely located as far from the antenna and the base as possible to ensure full power transmission from the base. Else, the base was wired to transmit full power.

The signal was maximized through rotation and placement in the three orthogonal axes. The antenna height and polarization were varied during the search for maximum signal level. The antenna height was varied from 1 to 4 meters. Radiated emissions were taken at three meters unless the signal level was too low for measurement at that distance. If necessary, a pre-amplifier was used and/or the test was conducted at a closer distance.

For any intentional radiator powered by AC power line, measurements of the radiated signal level of the fundamental frequency component of the emission was performed with the supply voltage varied between 85% and 115% of the nominal rated supply voltage.

For transmitter radiated measurement, the spectrum analyzer resolution bandwidth was 100 kHz for frequencies below 1000 MHz. The resolution bandwidth was 1 MHz for frequencies above 1000 MHz.

Radiated emission measurement for transmitter was performed from the lowest radio frequency signal generated in the device which is greater than 9 kHz to the tenth harmonic of the highest fundamental frequency or to 40 GHz, whichever is lower.

Emission that are directly caused by digital circuits in the transmit path and transmitter portion were measured, and the limit are according to FCC Part 15 Section 15.209. Digital circuitry used to control additional functions other than the operation of the transmitter are subject to FCC Part 15 Section 15.109 Limits.

The DECT module was put into transmission mode when taking radiated emission data for determining worst-case spurious emission.

TEST REPORT

3.1 Justification - Cont'd

Detector function for radiated emissions is in peak mode. Average readings, when required, are taken by measuring the duty cycle of the equipment under test and subtracting the corresponding amount in dB from the measured peak readings. A detailed description for the calculation of the average factor can be found in section 4.2.3.

Determination of pulse desensitization was made according to *Hewlett Packard Application Note 150-2, Spectrum Analysis... Pulsed RF*. The effective period (Teff) was 625 μ s. With the resolution bandwidth 1MHz and spectrum analyzer IF bandwidth 3dB, the pulse desensitization factor was 0dB.

For AC line conducted emission test, the EUT along with its peripherals were placed on a 1.0m(W)x1.5m(L) and 0.8m in height wooden table and the EUT was adjusted to maintain a 0.4 meter space from a vertical reference plane. The EUT was connected to power mains through a line impedance stabilization network (LISN), which provided 50ohm coupling impedance for measuring instrument. The LISN housing, measuring instrument case, reference ground plane, and vertical ground plane were bounded together. The excess power cable between the EUT and the LISN was bundled.

All connecting cables of EUT and peripherals were manipulated to find the maximum emission.

All relevant operation modes have been tested, and the worst case data was included in this report.

3.2 EUT Exercising Software

The EUT exercise program used during radiated and conducted testing was designed to exercise the various system components in a manner similar to a typical use.

TEST REPORT

3.3 Radiated Emission Test Setup

The figure below shows the test setup, which is utilized to make these measurements.

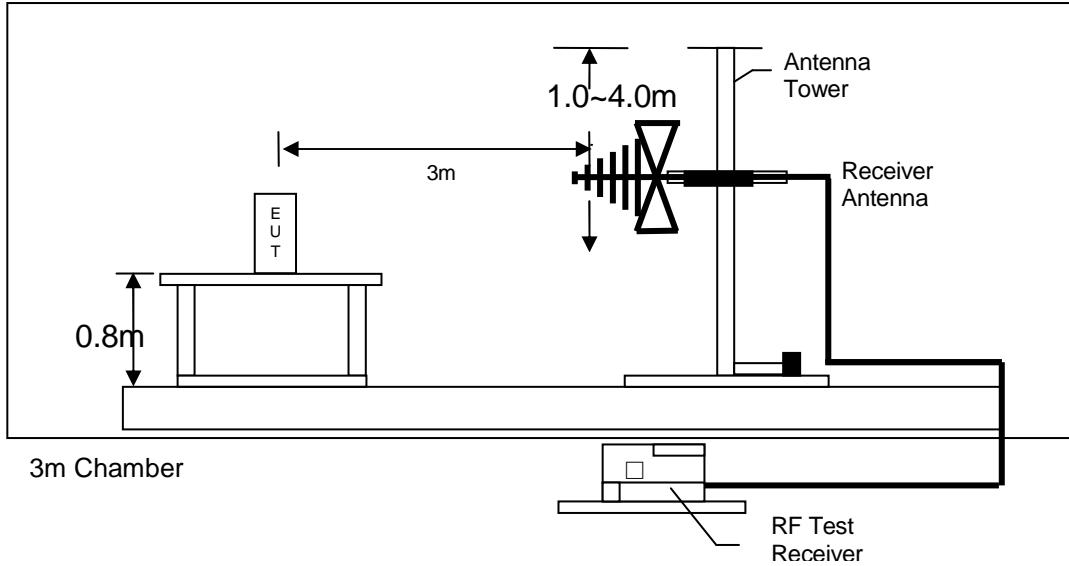

Figure 3.3.1 Test setup of radiated emissions up to 1GHz

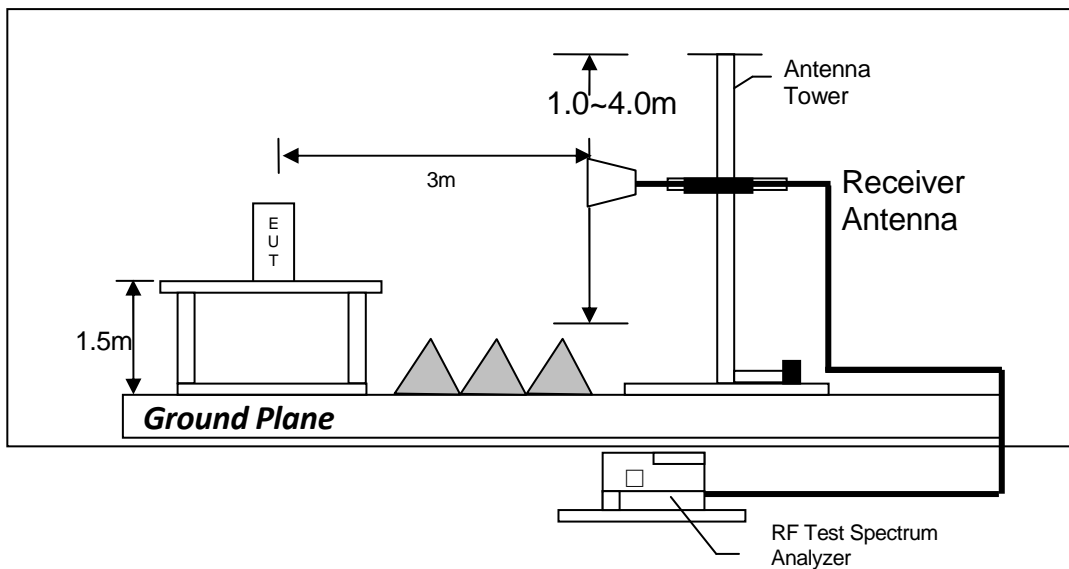

Figure 3.3.2 Test setup of radiated emissions above 1GHz

TEST REPORT

3.4 Conducted Emission Test Setup

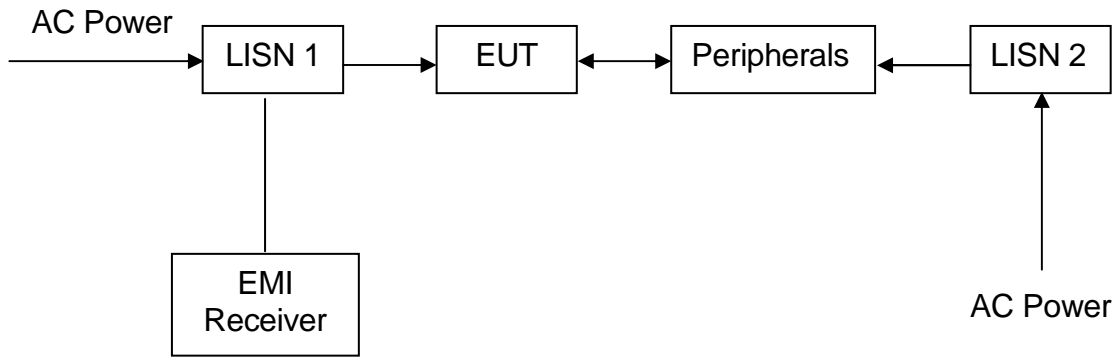

Figure 3.4.1

TEST REPORT**3.5 Details of EUT and Description of Accessories**Details of EUT:

An AC adaptor (provided with the unit) was used to power the device. Their description are listed below.

- (1) Base Unit: An AC adaptor (100-120VAC 60Hz 200mA to 6VDC 600mA, Model: S006AKU0600060) (Supplied by Client)

Description of Accessories:

- (1) Telephone Line Simulator, Model: TLS-5D-01, S/N: 151101 (Supplied by Intertek)
- (2) iphone 5c, Model: A1529, FCC ID: BCG-E2694A (Supplied by Intertek)
- (3) Handset, Model: TL96457, FCC ID: EW780-0381-00 (Supplied by Client)
- (4) 3m Telephone Line (Supplied by Intertek)
- (5) 1m Telephone Line with Termination (Supplied by Intertek)

3.6 Measurement Uncertainty

When determining of the test conclusion, the Measurement Uncertainty of test has been considered. The values of the Measurement uncertainty for radiated emission test, AC line conducted emission are $\pm 5.3\text{dB}$, $\pm 4.2\text{dB}$ respectively.

Uncertainty and Compliance - Unless the standard specifically states that measured values are to be extended by the measurement uncertainty in determining compliance, all compliance determinations are based on the actual measured value.

TEST REPORT

EXHIBIT 4 TEST RESULTS

4.0 Test Results

Data is included of the worst case configuration (the configuration which resulted in the highest emission levels). A sample calculation, configuration photographs and data tables of the emissions are included.

4.1 Field Strength Calculation

The field strength is calculated by adding the reading on the Spectrum Analyzer to the factors associated with preamplifiers (if any), antennas, cables, pulse desensitization and average factors (when specified limit is in average and measurements are made with peak detectors). A sample calculation is included below.

$$FS = RA + AF + CF - AG + PD + AV$$

where

- FS = Field Strength in dB μ V/m
- RA = Receiver Amplitude (including preamplifier) in dB μ V
- CF = Cable Attenuation Factor in dB
- AF = Antenna Factor in dB
- AG = Amplifier Gain in dB
- PD = Pulse Desensitization in dB
- AV = Average Factor in -dB

In the radiated emission table which follows, the reading shown on the data table may reflect the preamplifier gain. An example of the calculations, where the reading does not reflect the preamplifier gain, follows:

$$FS = RA + AF + CF - AG + PD + AV$$

Example

Assume a receiver reading of 62.0 dB μ V is obtained. The antenna factor of 7.4 dB and cable factor of 1.6 dB is added. The amplifier gain of 29 dB is subtracted. The pulse desensitization factor of the spectrum analyzer was 0 dB, and the resultant average factor was -10 dB. The net field strength for comparison to the appropriate emission limit is 32 dB μ V/m. This value in dB μ V/m was converted to its corresponding level in μ V/m.

$$\begin{aligned} RA &= 62.0 \text{ dB}\mu\text{V} \\ AF &= 7.4 \text{ dB} \\ CF &= 1.6 \text{ dB} \\ AG &= 29 \text{ dB} \\ PD &= 0 \text{ dB} \\ AV &= -10 \text{ dB} \\ FS &= 62 + 7.4 + 1.6 - 29 + 0 + (-10) = 32 \text{ dB}\mu\text{V/m} \end{aligned}$$

$$\text{Level in } \mu\text{V/m} = \text{Common Antilogarithm } [(32 \text{ dB}\mu\text{V/m})/20] = 39.8 \mu\text{V/m}$$

TEST REPORT

4.2 Radiated Emissions

4.2.1 Radiated Emission Configuration Photograph

Worst Case Radiated Emission
at

725.787 MHz

The worst case radiated emission configuration photographs are saved with filename: config photos.pdf

4.2.2 Radiated Emission Data

The data in tables 1-4 list the significant emission frequencies, the limit and the margin of compliance. Test setup is shown in section 3.3 Figure 3.3.1 and 3.3.2.

Judgement -

Passed by 3.3 dB margin

TEST REPORT

RADIATED EMISSION DATA

Mode: TX-Channel 00

Table 1, Base Unit

Polarization	Frequency (MHz)	Reading (dBµV)	Pre-Amp Gain (dB)	Antenna Factor (dB)	Net at 3m - Peak (dBµV/m)	Average Factor (dB)	Calculated at 3m (dBµV/m)	Average Limit at 3m (dBµV/m)	Margin (dB)
H	2402.000	98.6	33	29.4	95.0	24	71.0	94.0	-23.0
H	4804.000	63.6	33	34.9	65.5	24	41.5	54.0	-12.5
H	7206.000	45.6	33	37.9	50.5	24	26.5	54.0	-27.5
H	9608.000	50.3	33	40.4	57.7	24	33.7	54.0	-20.3
V	12010.000	45.1	33	40.5	52.6	24	28.6	54.0	-25.4
V	14412.000	46.8	33	40.0	53.8	24	29.8	54.0	-24.2

Polarization	Frequency (MHz)	Reading (dBµV)	Pre-Amp Gain (dB)	Antenna Factor (dB)	Net at 3m - Peak (dBµV/m)	Peak Limit at 3m (dBµV/m)	Margin (dB)
H	2402.000	98.6	33	29.4	95.0	114.0	-19.0
H	4804.000	63.6	33	34.9	65.5	74.0	-8.5
H	7206.000	45.6	33	37.9	50.5	74.0	-23.5
H	9608.000	50.3	33	40.4	57.7	74.0	-16.3
V	12010.000	45.1	33	40.5	52.6	74.0	-21.4
V	14412.000	46.8	33	40.0	53.8	74.0	-20.2

- NOTES:
1. Peak detector is used for the emission measurement.
 2. All measurements were made at 3 meters. Radiated emissions not detected at the 3-meter distance were measured at 0.3-meter and an inverse proportional extrapolation was performed to compare the signal level to the 3-meter limit. No other radiated emissions than those reported were detected at a test distance of 0.3-meter.
 3. Negative value in the margin column shows emission below limit.
 4. Horn antenna is used for the emission over 1000MHz.
 5. Emission (the row indicated by **bold italic**) within the restricted band meets the requirement of FCC Part 15 Section 15.205.

TEST REPORT

Mode: TX-Channel 39

Table 2, Base Unit

Polarization	Frequency (MHz)	Reading (dBµV)	Pre-Amp Gain (dB)	Antenna Factor (dB)	Net at 3m - Peak (dBµV/m)	Average Factor (dB)	Calculated at 3m (dBµV/m)	Average Limit at 3m (dBµV/m)	Margin (dB)
H	2440.000	99.5	33	29.4	95.9	24	71.9	94.0	-22.1
H	4880.000	63.5	33	34.9	65.4	24	41.4	54.0	-12.6
H	7320.000	45.9	33	37.9	50.8	24	26.8	54.0	-27.2
H	9760.000	49.7	33	40.4	57.1	24	33.1	54.0	-20.9
V	12200.000	44.8	33	40.5	52.3	24	28.3	54.0	-25.7
V	14640.000	48.3	33	38.4	53.7	24	29.7	54.0	-24.3

Polarization	Frequency (MHz)	Reading (dBµV)	Pre-Amp Gain (dB)	Antenna Factor (dB)	Net at 3m - Peak (dBµV/m)	Peak Limit at 3m (dBµV/m)	Margin (dB)
H	2440.000	99.5	33	29.4	95.9	114.0	-18.1
H	4880.000	63.5	33	34.9	65.4	74.0	-8.6
H	7320.000	45.9	33	37.9	50.8	74.0	-23.2
H	9760.000	49.7	33	40.4	57.1	74.0	-16.9
V	12200.000	44.8	33	40.5	52.3	74.0	-21.7
V	14640.000	48.3	33	38.4	53.7	74.0	-20.3

- NOTES:
1. Peak detector is used for the emission measurement.
 2. All measurements were made at 3 meters. Radiated emissions not detected at the 3-meter distance were measured at 0.3-meter and an inverse proportional extrapolation was performed to compare the signal level to the 3-meter limit. No other radiated emissions than those reported were detected at a test distance of 0.3-meter.
 3. Negative value in the margin column shows emission below limit.
 4. Horn antenna is used for the emission over 1000MHz.
 5. Emission (the row indicated by **bold italic**) within the restricted band meets the requirement of FCC Part 15 Section 15.205.

TEST REPORT

Mode: TX-Channel 78

Table 3, Base Unit

Polarization	Frequency (MHz)	Reading (dBµV)	Pre-Amp Gain (dB)	Antenna Factor (dB)	Net at 3m - Peak (dBµV/m)	Average Factor (dB)	Calculated at 3m (dBµV/m)	Average Limit at 3m (dBµV/m)	Margin (dB)
H	2480.000	99.0	33	29.4	95.4	24	71.4	94.0	-22.6
H	4960.000	63.7	33	34.9	65.6	24	41.6	54.0	-12.4
H	7440.000	45.7	33	37.9	50.6	24	26.6	54.0	-27.4
H	9920.000	50.1	33	40.4	57.5	24	33.5	54.0	-20.5
V	12400.000	44.9	33	40.5	52.4	24	28.4	54.0	-25.6
V	14880.000	48.1	33	38.4	53.5	24	29.5	54.0	-24.5

Polarization	Frequency (MHz)	Reading (dBµV)	Pre-Amp Gain (dB)	Antenna Factor (dB)	Net at 3m - Peak (dBµV/m)	Peak Limit at 3m (dBµV/m)	Margin (dB)
H	2480.000	99.0	33	29.4	95.4	114.0	-18.6
H	4960.000	63.7	33	34.9	65.6	74.0	-8.4
H	7440.000	45.7	33	37.9	50.6	74.0	-23.4
H	9920.000	50.1	33	40.4	57.5	74.0	-16.5
V	12400.000	44.9	33	40.5	52.4	74.0	-21.6
V	14880.000	48.1	33	38.4	53.5	74.0	-20.5

- NOTES:
1. Peak detector is used for the emission measurement.
 2. All measurements were made at 3 meters. Radiated emissions not detected at the 3-meter distance were measured at 0.3-meter and an inverse proportional extrapolation was performed to compare the signal level to the 3-meter limit. No other radiated emissions than those reported were detected at a test distance of 0.3-meter.
 3. Negative value in the margin column shows emission below limit.
 4. Horn antenna is used for the emission over 1000MHz.
 5. Emission (the row indicated by **bold italic**) within the restricted band meets the requirement of FCC Part 15 Section 15.205.

TEST REPORT

Mode: Ringing and Charging with Bluetooth

Table 4, Base Unit

Radiated Emission Data

Polarization	Frequency (MHz)	Reading (dBµV)	Pre-amp (dB)	Antenna Factor (dB)	Net at 3m (dBµV/m)	Limit at 3m (dBµV/m)	Margin (dB)
V	32.345	32.5	16	10.0	26.5	40.0	-13.5
H	148.965	32.4	16	14.0	30.4	43.5	-13.1
V	207.345	36.5	16	17.0	37.5	43.5	-6.0
V	311.034	26.6	16	23.0	33.6	46.0	-12.4
H	414.676	32.8	16	25.0	41.8	46.0	-4.2
H	725.787	28.7	16	30.0	42.7	46.0	-3.3
H	829.645	24.5	16	31.0	39.5	46.0	-6.5
H	933.823	21.3	16	33.0	38.3	46.0	-7.7

- NOTES:
1. Peak detector is used for the emission measurement.
 2. All measurements were made at 3 meters. Radiated emissions not detected at the 3-meter distance were measured at 0.3-meter and an inverse proportional extrapolation was performed to compare the signal level to the 3-meter limit. No other radiated emissions than those reported were detected at a test distance of 0.3-meter.
 3. Negative value in the margin column shows emission below limit.
 4. Emission (the row indicated by ***bold italic***) within the restricted band meets the requirement of FCC Part 15 Section 15.205.

TEST REPORT**4.2.3 Transmitter Duty Cycle Calculation**

Based on the Bluetooth Specification Version 2.0 / 2.1 + EDR, the transmitter ON time for each timeslot of Bluetooth is 625 μ s. DH5 has the maximum duty cycle, which consists of 5 continuous Tx slots and 1 Rx slot. Therefore one hopset take $(5+1) \times 625\mu\text{s} = 3.75\text{ms}$. For one period for a pseudo-random hopping through at least 20 RF channels in adaptive mode (worst case), it take: $20 \times 3.75\text{ms} = 75\text{ms}$.

The dwell time for DH5 is $5 \times 625\mu\text{s} = 3.125\text{ms}$

For the worst case calculation, there are two transmissions might occur in 100ms.

Therefore,

$$\begin{aligned}\text{Duty Cycle (DC)} &= \text{Maximum On time in } 100\text{ms}/100\text{ms} \\ &= 3.125\text{ms} \times 2 / 100\text{ms} \\ &= 0.0625\end{aligned}$$

$$\begin{aligned}\text{Average Factor (AF) of Bluetooth in dB} &= 20 \log_{10} (0.0625) \\ &= -24.0\text{dB}\end{aligned}$$

4.3 Radiated Emission on the Bandedge

From the following plots, they show that the fundamental emissions are confined in the specified band (2400MHz and 2483.5MHz). In case of emissions up to two standard bandwidths away from the bandedge, the delta measurement technique is used for determining bandedge compliance. Standard bandwidth is the bandwidth specified by ANSI C63.4 (2014) for frequency being measured.

Emissions radiated outside of the specified frequency bands, except harmonics, are attenuated by 50 dB below the level of the fundamental or to the general radiated emission limits in FCC Part 15 Section 15.209, whichever is the lesser attenuation, which meet the requirement of FCC Part 15 Section 15.249(d).

The plots of radiated emission on the bandedge are saved as below.

TEST REPORT

Plots of radiated emission on the bandedge

Lowest channel

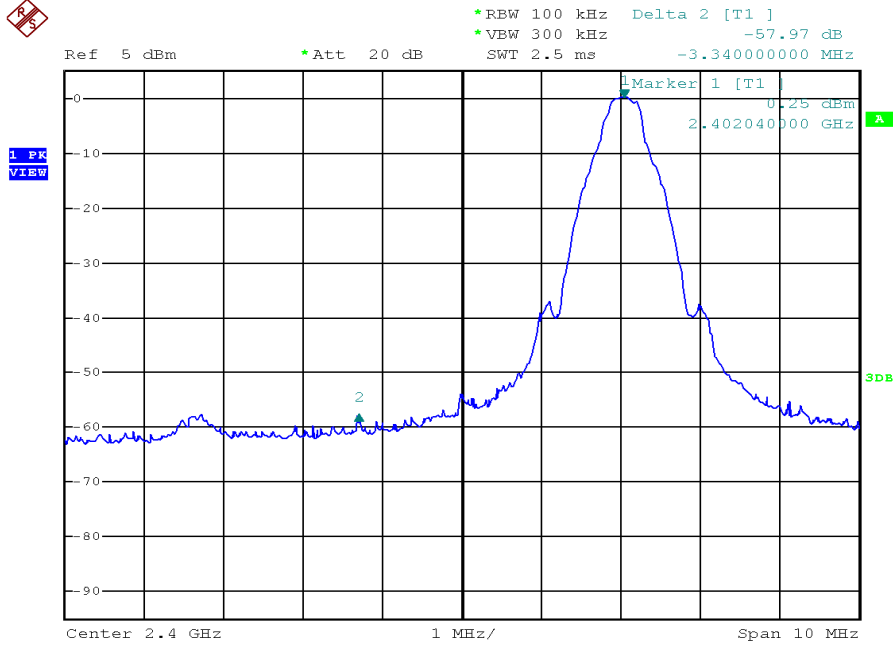

Highest channel

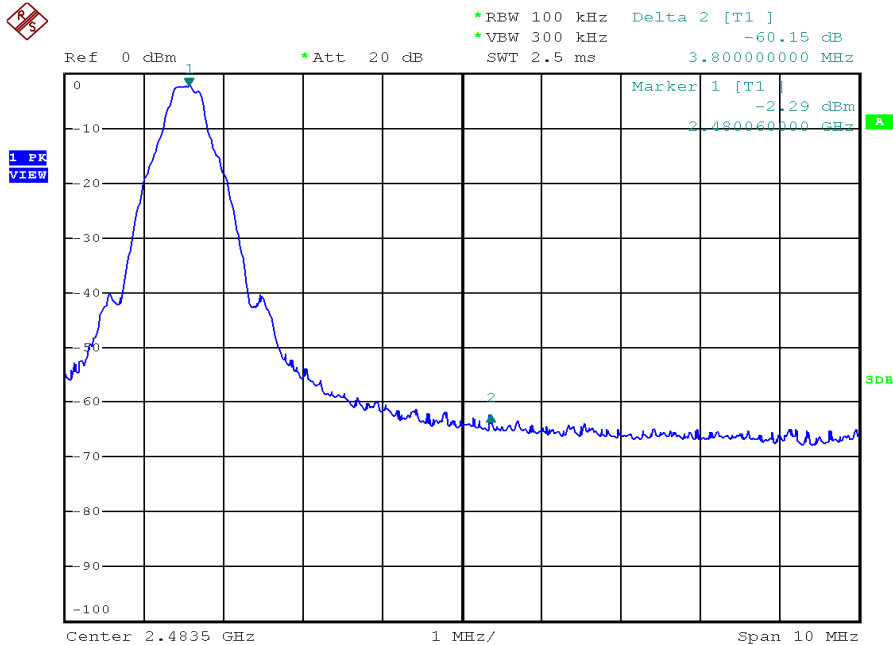

TEST REPORT

Bandedge compliance is determined by applying marker-delta method, i.e.

Resultant Field Strength = Fundamental Emissions - Delta from the plot

Resultant field strength for the lowest and/or highest channel(s), with corresponding average values are calculated as follows:

AC adaptor	Channel	Fundamental Emission (dBµV/m)	Delta from the Plot (dB)	Resultant Field Strength (dBµV/m)	Average Limit (dBµV/m)	Margin (dB)
Ten Pao	Lowest	71.0	57.97	13.03	54	-40.97
	Highest	71.4	60.15	11.25	54	-42.75

Ac adaptor	Channel	Fundamental Emission (dBµV/m)	Delta from the Plot (dB)	Resultant Field Strength (dBµV/m)	Peak Limit (dBµV/m)	Margin (dB)
Ten Pao	Lowest	95.0	57.97	37.03	74	-36.97
	Highest	95.4	60.15	35.25	74	-38.75

The resultant field strength meets the general radiated emission limit in FCC Part 15 Section 15.209, which does not exceed 74dBµV/m for peak limit and also 54dBµV/m for average limit.

TEST REPORT

4.4 AC Power Line Conducted Emission

- [] Not applicable – EUT is only powered by battery for operation.
- [x] EUT connects to AC power line. Emission Data is listed in following pages.
- [] Base Unit connects to AC power line and has transmission. Handset connects to AC power line but has no transmission. Emission Data of Base Unit is listed in following pages.

Test setup is shown in section 3.4 Figure 3.4.1.

4.4.1 AC Power Line Conducted Emission Configuration Photograph

Worst Case Line-Conducted Configuration
at

339 kHz

The worst case line conducted configuration photographs are saved with filename: config photos.pdf.

4.3.2 AC Power Line Conducted Emission Data

The plot(s) and data in the following pages list the significant emission frequencies, the limit and the margin of compliance.

Passed by 10.02 dB margin compared with average limit

TEST REPORT

CONDUCTED EMISSION DATA

Worst Case: Ringing and Charging with Bluetooth

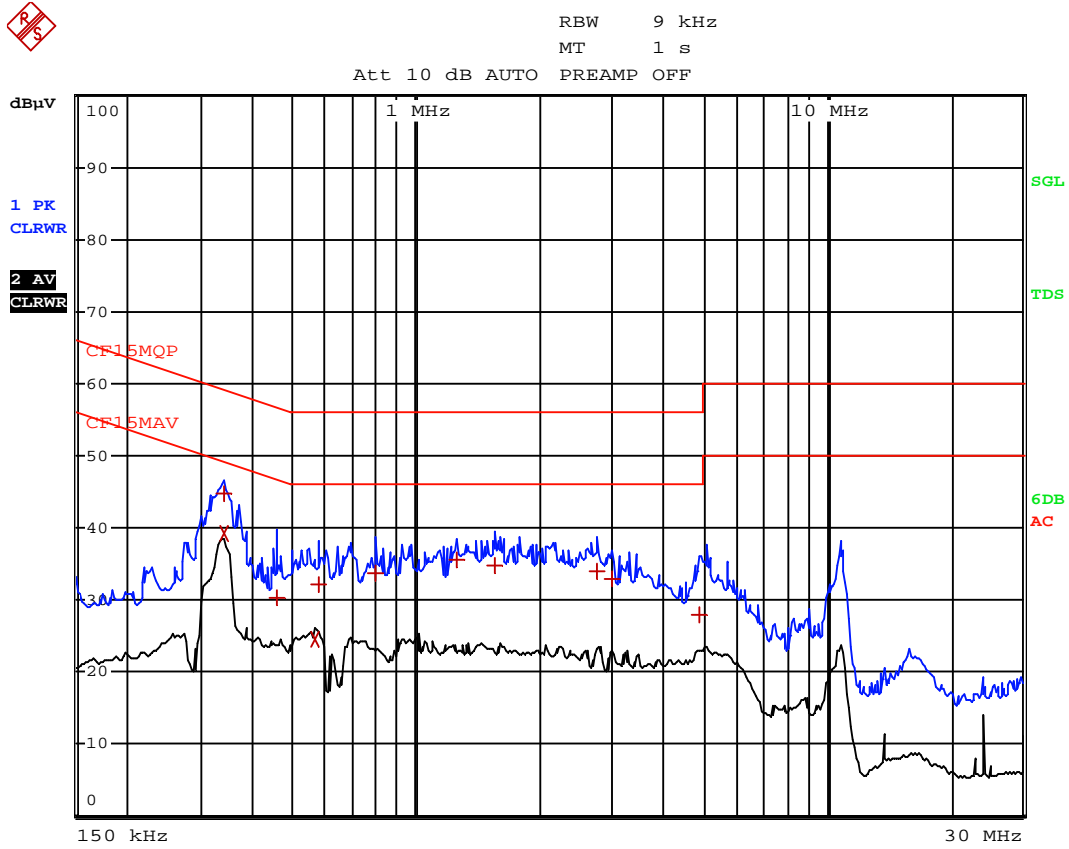

TEST REPORT

Worst Case: Ringing and Charging with Bluetooth

EDIT PEAK LIST (Final Measurement Results)				
Trace1:	CF15MQP			
Trace2:	CF15MAV			
Trace3:	---			
TRACE	FREQUENCY	LEVEL dBµV		DELTA LIMIT dB
1 Quasi Peak	339 kHz	44.70	L1	-14.52
2 CISPR Average	339 kHz	39.20	L1	-10.02
1 Quasi Peak	456 kHz	30.23	N	-26.52
2 CISPR Average	568.5 kHz	24.41	L1	-21.58
1 Quasi Peak	577.5 kHz	32.12	N	-23.87
1 Quasi Peak	798 kHz	33.82	N	-22.17
1 Quasi Peak	1.257 MHz	35.49	N	-20.50
1 Quasi Peak	1.554 MHz	34.75	N	-21.24
1 Quasi Peak	2.7735 MHz	33.94	N	-22.05
1 Quasi Peak	2.9985 MHz	32.87	N	-23.12
1 Quasi Peak	4.875 MHz	27.97	L1	-28.03

TEST REPORT

EXHIBIT 5 EQUIPMENT LIST

5.0 Equipment List

1) Radiated Emissions Test

EQUIPMENT	Biconilog Antenna	Log Periodic Antenna	Spectrum Analyzer
Registration No.	EW-3061	EW-0447	EW-3110
Manufacturer	EMCO	EMCO	R&S
Model No.	3412E	3146	FSP30
Calibration Date	Sep. 23, 2016	May 18, 2016	Feb. 06, 2017
Calibration Due Date	Sep. 23, 2017	Nov 18, 2017	Feb. 06, 2018

EQUIPMENT	Emi Test Receiver (9khz To 26.5ghz)	Broad-Band Horn Antenna	Double Ridged Guide Antenna
Registration No.	EW-3156	EW-1679	EW-0194
Manufacturer	ROHDESCHWARZ	SCHWARZBECK	EMCO
Model No.	ESR26	BBHA9170	3115
Calibration Date	Dec. 06. 2016	Jun. 28, 2016	Aug. 10, 2016
Calibration Due Date	Dec. 06, 2017	Jun. 28, 2017	Feb. 10, 2018

2) Conducted Emissions Test

EQUIPMENT	EMI Test Receiver	LISN
Registration No.	EW-2500	EW-2874
Manufacturer	R&S	R&S
Model No.	ESCI	ENV-216
Calibration Date	Nov. 17, 2016	Mar. 16, 2017
Calibration Due Date	Nov. 15, 2017	Mar. 16, 2018

3) Bandedge Measurement Test

EQUIPMENT	Spectrum Analyzer
Registration No.	EW-3110
Manufacturer	R&S
Model No.	FSP30
Calibration Date	Feb. 06, 2017
Calibration Due Date	Feb. 06, 2018

END OF TEST REPORT