



Valued Quality. Delivered.

## TEST REPORT

**Report Number: 16040719HKG-002**

Application  
for  
Original of 47 CFR Part 15 Certification  
New Family of RSS-210 Issue 8 Equipment Certification

1.9GHz Digital Modulation Cordless Phone with Caller ID,  
Speakerphone, Digital Answering Machine and Bluetooth - Base Unit  
Bluetooth Portion

**FCC ID: EW780-0381-00**

**IC: 1135B-80038100**

Prepared and Checked by:

Approved by:

***Signed on File***

Leung Chiu Kuen, Stanley  
Engineer

---

Koo Wai Ip  
Assistant Supervisor  
May 30, 2016

- Intertek's standard Terms and Conditions can be obtained at our website: <http://www.intertek.com/terms/>.
- The test report only allows to be revised within the retention period unless further standard or the requirement was noticed.
- This report is for the exclusive use of Intertek's Client and is provided pursuant to the agreement between Intertek and its Client. Intertek's responsibility and liability are limited to the terms and conditions of the agreement. Intertek assumes no liability to any party, other than to the Client in accordance with the agreement, for any loss, expense or damage occasioned by the use of this report. Only the Client is authorized to permit copying or distribution of this report and then only in its entirety. Any use of the Intertek name or one of its marks for the sale or advertisement of the tested material, product or service must first be approved in writing by Intertek. The observations and test results in this report are relevant only to the sample tested. This report by itself does not imply that the material, product, or service is or has ever been under an Intertek certification program.
- © 2016 Intertek

**Intertek Testing Services Hong Kong Ltd.**

2/F., Garment Centre, 576 Castle Peak Road, Kowloon, Hong Kong.  
Tel: (852) 2173 8888 Fax: (852) 2785 5487 Website: [www.hk.intertek-etlsemko.com](http://www.hk.intertek-etlsemko.com)

## INTERTEK TESTING SERVICES

---

### GENERAL INFORMATION

<b>Applicant Name:</b>	VTech Telecommunications Ltd.
<b>Applicant Address:</b>	23/F., Tai Ping Industrial Centre, Block 1, 57 Ting Kok Road, Tai Po, Hong Kong.
<b>FCC Specification Standard:</b>	FCC Part 15, October 1, 2014 Edition
<b>FCC ID:</b>	EW780-0381-00
<b>FCC Model(s):</b>	TL96456, TL96276, TL96XY6, TL96456 BS, TL96276 BS, TL96XY6 BS
<b>IC Specification Standard:</b>	RSS-210 Issue 8, December 2010 RSS-Gen Issue 4, November 2014
<b>IC:</b>	1135B-80038100
<b>IC Model(s):</b>	TL96456 BS, TL96276 BS
<b>Type of EUT:</b>	Transceiver
<b>Description of EUT:</b>	1.9GHz Digital Modulation Cordless Phone with Caller ID, Speakerphone, Digital Answering Machine and Bluetooth - Base Unit Bluetooth Portion
<b>Serial Number:</b>	N/A
<b>Sample Receipt Date:</b>	April 20, 2016
<b>Date of Test:</b>	April 21 - May 17, 2016
<b>Report Date:</b>	May 30, 2016
<b>Environmental Conditions:</b>	Temperature: +10 to 40°C Humidity: 10 to 90%

---

# INTERTEK TESTING SERVICES

---

## Table of Contents

<b>1.0 Test Results Summary &amp; Statement of Compliance</b> .....	4
1.1 Summary of Test Results .....	4
1.2 Statement of Compliance .....	4
<b>2.0 General Description</b> .....	6
2.1 Product Description .....	6
2.2 Test Methodology .....	6
2.3 Test Facility .....	6
<b>3.0 System Test Configuration</b> .....	8
3.1 Justification .....	8
3.2 EUT Exercising Software .....	9
3.3 Radiated Emission Test Setup .....	10
3.4 Conducted Emission Test Setup .....	11
3.5 Details of EUT and Description of Accessories .....	11
3.6 Measurement Uncertainty .....	11
<b>4.0 Test Results</b> .....	13
4.1 Field Strength Calculation .....	13
4.2 Radiated Emissions .....	14
4.2.1 Radiated Emission Configuration Photograph .....	14
4.2.2 Radiated Emission Data .....	14
4.2.3 Transmitter Duty Cycle Calculation .....	19
4.3 Radiated Emission on the Bandedge .....	19
4.4 AC Power Line Conducted Emission .....	22
4.4.1 AC Power Line Conducted Emission Configuration Photograph .....	22
4.4.2 AC Power Line Conducted Emission Data .....	22
<b>5.0 Equipment List</b> .....	26

**INTERTEK TESTING SERVICES**

---

**EXHIBIT 1  
TEST RESULTS SUMMARY & STATEMENT OF COMPLIANCE**

# INTERTEK TESTING SERVICES

---

## 1.0 Test Results Summary & Statement of Compliance

### 1.1 Summary of Test Results

Test Items	FCC Part 15 Section	RSS-210/ RSS-Gen#/ RSS-310^ Section	Results	Details see section
Antenna Requirement	15.203	8.3#	Pass	2.1
Security Code Information	15.214(d)	2.4	Pass	2.1
Radiated Emission	15.249(a), 209, & 109	A2.9(a)	Pass	4.2
Radiated Emission on the Bandedge	15.249(d)	A2.9(b)	Pass	4.3
Radiated Emission in Restricted Bands	15.205	2.2	Pass	4.2
AC Power Line Conducted Emission	15.207 & 15.107	8.8#	Pass	4.4

Note: Pursuant to FCC Part 15 Section 15.215(c), the 20dB bandwidth of the emission was contained within the frequency band designated (mentioned as above) which the EUT operated. The effects, if any, from frequency sweeping, frequency hopping, other modulation techniques and frequency stability over expected variations in temperature and supply voltage were considered.

### 1.2 Statement of Compliance

The equipment under test is found to be complying with the following standards:

FCC Part 15, October 1, 2014 Edition  
RSS-210 Issue 8, December 2010  
RSS-Gen Issue 4, November 2014

**INTERTEK TESTING SERVICES**

---

**EXHIBIT 2  
GENERAL DESCRIPTION**

---

## INTERTEK TESTING SERVICES

---

### 2.0 General Description

#### 2.1 Product Description

The TL96276 is a 1.9GHz Digital Modulation Cordless Phone with Caller ID, Speakerphone, Digital Answering Machine and Bluetooth. - Base Unit Bluetooth Portion. Only Base Unit has Bluetooth feature and it operates at frequency range of 2402MHz to 2480MHz. The Base Unit is powered by an adaptor 100-120VAC to 6VDC 600mA. With Bluetooth device registered and enabled, the Base Unit allows user uses the cordless handset to make or receive cellular phone calls via the cellular network. Two Bluetooth devices can be connected at the same time.

The Bluetooth antenna used in base unit is integral, and the test sample is a prototype.

For FCC, base unit of Model(s): TL96456, TL96XY6, TL96456 BS, TL96276 BS, TL96XY6 BS are the same as the Model: TL96276 in electrical designs including software & firmware, PCB layout and construction design/physical design/enclosure. The only differences between these models are color, model number, package type and number of handsets and Chargers to be sold for marketing purpose. Suffix (X, Y) indicates alphanumeric character is representing different number of handset(s) and charger(s) and different package type or color of enclosure.

For IC, base unit of Model(s): TL96456 BS is the same as the Model: TL96276 BS in electronics/electrical designs including software & firmware, PCB layout and construction design/physical design/enclosure. The only differences between these models are color and model number to be sold for marketing purpose.

The circuit description is saved with filename: descri.pdf.

Connection between the device and the telephone network is accomplished through the use of USOC RJ11C in the 2-wire loop calling central office line.

#### 2.2 Test Methodology

Both AC power line-conducted and radiated emission measurements were performed according to the procedures in ANSI C63.4 (2014) and ANSI C63.10 (2013). Preliminary radiated scans and all radiated measurements were performed in Radiated Emission Test Sites. All Radiated tests were performed at an antenna to EUT distance of 3 meters, unless stated otherwise in the "**Justification Section**" of this Application.

#### 2.3 Test Facility

The radiated emission test sites and conducted measurement facility used to collect the radiated data and conducted data are at Workshop No. 3, G/F., World-Wide Industrial Centre, 43-47 Shan Mei Street, Fo Tan, Sha Tin, N.T., Hong Kong. This test facility and site measurement data have been fully placed on file with the FCC and IC No. 2042V.

**INTERTEK TESTING SERVICES**

---

**EXHIBIT 3  
SYSTEM TEST CONFIGURATION**

## **INTERTEK TESTING SERVICES**

---

### **3.0 System Test Configuration**

#### **3.1 Justification**

For radiated emissions testing, the equipment under test (EUT) was setup to transmit continuously mode to simplify the measurement methodology. Care was taken to ensure proper power supply voltages during testing. During testing, all cables (if any) were manipulated to produce worst case emissions.

The Base Unit was powered by 100-120VAC 60Hz 200mA to 6VDC 600mA adaptor.

For the measurements, the EUT was attached to a plastic stand if necessary and placed on the wooden turntable which is four feet in diameter and approximately 0.8m in height above the ground plane for emission measurement at or below 1GHz and 1.5m in height above the ground plane for emission measurement above 1GHz. If the base unit attached to peripherals, they were connected and operational to simulate typical use. The handset was remotely located as far from the antenna and the base as possible to ensure full power transmission from the base. Else, the base was wired to transmit full power.

The signal was maximized through rotation and placement in the three orthogonal axes. The antenna height and polarization were varied during the search for maximum signal level. The antenna height was varied from 1 to 4 meters. Radiated emissions were taken at three meters unless the signal level was too low for measurement at that distance. If necessary, a pre-amplifier was used and/or the test was conducted at a closer distance.

For any intentional radiator powered by AC power line, measurements of the radiated signal level of the fundamental frequency component of the emission was performed with the supply voltage varied between 85% and 115% of the nominal rated supply voltage.

For transmitter radiated measurement, the spectrum analyzer resolution bandwidth was 100 kHz for frequencies below 1000 MHz. The resolution bandwidth was 1 MHz for frequencies above 1000 MHz.

Radiated emission measurement for transmitter was performed from the lowest radio frequency signal generated in the device which is greater than 9 kHz to the tenth harmonic of the highest fundamental frequency or to 40 GHz, whichever is lower.

Emission that are directly caused by digital circuits in the transmit path and transmitter portion were measured, and the limit are according to FCC Part 15 Section 15.209. Digital circuitry used to control additional functions other than the operation of the transmitter are subject to FCC Part 15 Section 15.109 Limits.

The DECT module was put into transmission mode when taking radiated emission data for determining worst-case spurious emission.

## INTERTEK TESTING SERVICES

---

### 3.1 Justification - Cont'd

Detector function for radiated emissions is in peak mode. Average readings, when required, are taken by measuring the duty cycle of the equipment under test and subtracting the corresponding amount in dB from the measured peak readings. A detailed description for the calculation of the average factor can be found in section 4.2.3.

Determination of pulse desensitization was made according to *Hewlett Packard Application Note 150-2, Spectrum Analysis... Pulsed RF*. The effective period (Teff) was 625 $\mu$ s. With the resolution bandwidth 1MHz and spectrum analyzer IF bandwidth 3dB, the pulse desensitization factor was 0dB.

For AC line conducted emission test, the EUT along with its peripherals were placed on a 1.0m(W)x1.5m(L) and 0.8m in height wooden table and the EUT was adjusted to maintain a 0.4 meter space from a vertical reference plane. The EUT was connected to power mains through a line impedance stabilization network (LISN), which provided 50ohm coupling impedance for measuring instrument. The LISN housing, measuring instrument case, reference ground plane, and vertical ground plane were bounded together. The excess power cable between the EUT and the LISN was bundled.

All connecting cables of EUT and peripherals were manipulated to find the maximum emission.

All relevant operation modes have been tested, and the worst case data was included in this report.

### 3.2 EUT Exercising Software

The EUT exercise program used during radiated and conducted testing was designed to exercise the various system components in a manner similar to a typical use.

# INTERTEK TESTING SERVICES

## 3.3 Radiated Emission Test Setup

The figure below shows the test setup, which is utilized to make these measurements.

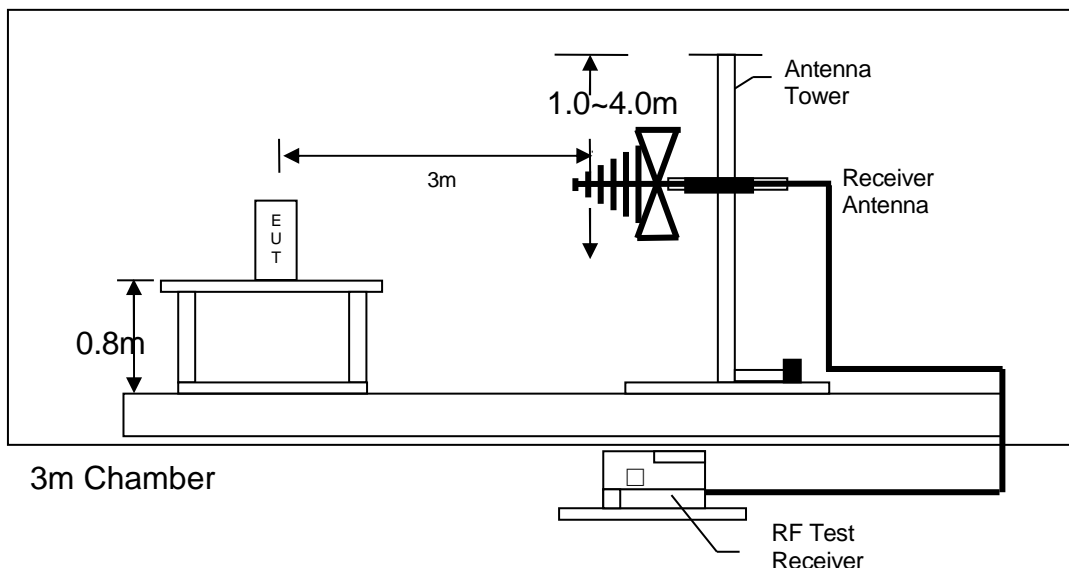

Figure 3.3.1 Test setup of radiated emissions up to 1GHz

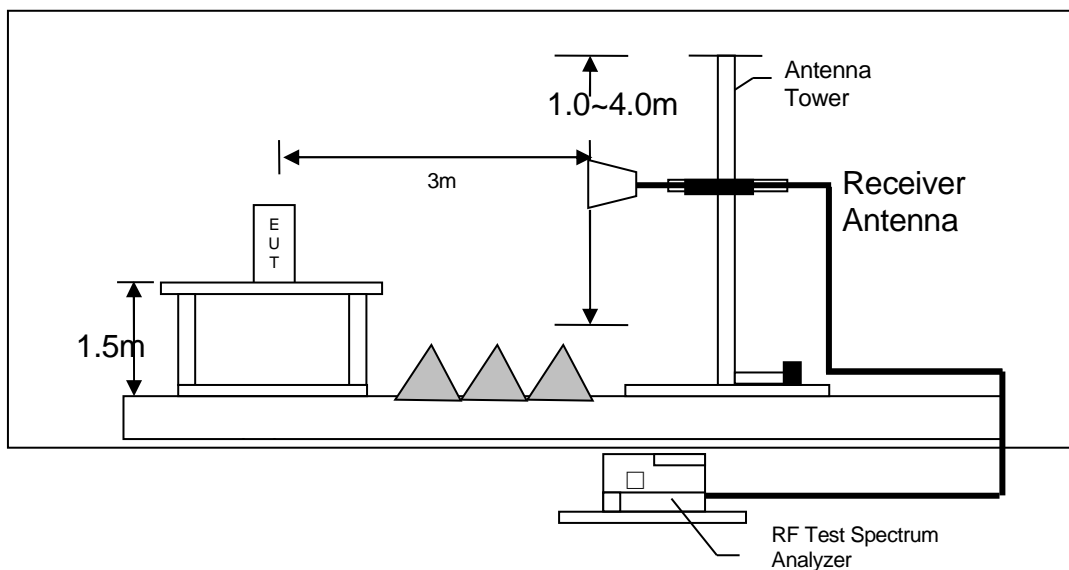

Figure 3.3.2 Test setup of radiated emissions above 1GHz

## INTERTEK TESTING SERVICES

---

### 3.4 Conducted Emission Test Setup

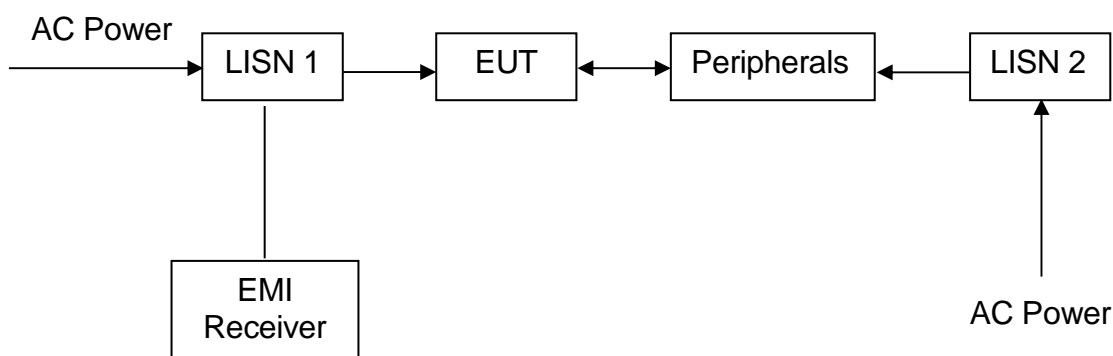

Figure 3.4.1

### 3.5 Details of EUT and Description of Accessories

#### Details of EUT:

An AC adaptor (provided with the unit) was used to power the device. Their description are listed below.

- (1) Base Unit: An AC adaptor ((100-120VAC 60Hz 200mA to 6VDC 600mA, Model: S006AKU0600060) (Supplied by Client)

#### Description of Accessories:

- (1) Telephone Line Simulator, Model: TLS-5D-01, S/N: 151101 (Supplied by Intertek)
- (2) iphone 5c, Model: A1529, FCC ID: BCG-E2694A (Supplied by Intertek)
- (3) Handset, Model: TL96276, FCC ID: EW780-0381-00 (Supplied by Client)
- (4) 3m Telephone Line (Supplied by Intertek)
- (5) 1m Telephone Line with Termination (Supplied by Intertek)

### 3.6 Measurement Uncertainty

When determining of the test conclusion, the Measurement Uncertainty of test has been considered. The values of the Measurement uncertainty for radiated emission test and AC line conducted emission test timing jitter are  $\pm 5.3\text{dB}$ ,  $\pm 4.2\text{dB}$  respectively.

Uncertainty and Compliance - Unless the standard specifically states that measured values are to be extended by the measurement uncertainty in determining compliance, all compliance determinations are based on the actual measured value.

**INTERTEK TESTING SERVICES**

---

**EXHIBIT 4  
TEST RESULTS**

---

## INTERTEK TESTING SERVICES

---

### 4.0 Test Results

Data is included of the worst case configuration (the configuration which resulted in the highest emission levels). A sample calculation, configuration photographs and data tables of the emissions are included.

#### 4.1 Field Strength Calculation

The field strength is calculated by adding the reading on the Spectrum Analyzer to the factors associated with preamplifiers (if any), antennas, cables, pulse desensitization and average factors (when specified limit is in average and measurements are made with peak detectors). A sample calculation is included below.

$$FS = RA + AF + CF - AG + PD + AV$$

where

- FS = Field Strength in dB $\mu$ V/m
- RA = Receiver Amplitude (including preamplifier) in dB $\mu$ V
- CF = Cable Attenuation Factor in dB
- AF = Antenna Factor in dB
- AG = Amplifier Gain in dB
- PD = Pulse Desensitization in dB
- AV = Average Factor in -dB

In the radiated emission table which follows, the reading shown on the data table may reflect the preamplifier gain. An example of the calculations, where the reading does not reflect the preamplifier gain, follows:

$$FS = RA + AF + CF - AG + PD + AV$$

#### Example

Assume a receiver reading of 62.0 dB $\mu$ V is obtained. The antenna factor of 7.4 dB and cable factor of 1.6 dB is added. The amplifier gain of 29 dB is subtracted. The pulse desensitization factor of the spectrum analyzer was 0 dB, and the resultant average factor was -10 dB. The net field strength for comparison to the appropriate emission limit is 32 dB $\mu$ V/m. This value in dB $\mu$ V/m was converted to its corresponding level in  $\mu$ V/m.

RA = 62.0 dB $\mu$ V  
AF = 7.4 dB  
CF = 1.6 dB  
AG = 29 dB  
PD = 0 dB  
AV = -10 dB  
FS = 62 + 7.4 + 1.6 - 29 + 0 + (-10) = 32 dB $\mu$ V/m

Level in  $\mu$ V/m = Common Antilogarithm [(32 dB $\mu$ V/m)/20] = 39.8  $\mu$ V/m

## INTERTEK TESTING SERVICES

---

### 4.2 Radiated Emissions

#### 4.2.1 Radiated Emission Configuration Photograph

Worst Case Radiated Emission  
at  
4960.000 MHz

The worst case radiated emission configuration photographs are saved with filename: config photos.pdf

#### 4.2.2 Radiated Emission Data

The data in tables 1-4 list the significant emission frequencies, the limit and the margin of compliance. Test setup is shown in section 3.3 Figure 3.3.1 and 3.3.2.

Judgement -

Passed by 8.1 dB margin compare to peak limit

## INTERTEK TESTING SERVICES

Mode: TX-Channel 00

Table 1, Base Unit

### Radiated Emission Data

Polarization	Frequency (MHz)	Reading (dB $\mu$ V)	Pre-Amp Gain (dB)	Antenna Factor (dB)	Average Factor (dB)	Calculated at 3m (dB $\mu$ V/m)	Average Limit at 3m (dB $\mu$ V/m)	Margin (dB)
H	2402.000	98.6	33	29.4	24	71.0	94.0	-23.0
<b>V</b>	<b>4804.000</b>	<b>63.4</b>	<b>33</b>	<b>34.9</b>	<b>24</b>	<b>41.3</b>	<b>54.0</b>	<b>-12.7</b>
V	7206.000	46.6	33	37.9	24	27.5	54.0	-26.5
V	9608.000	49.3	33	40.4	24	32.7	54.0	-21.3
<b>V</b>	<b>12010.000</b>	<b>46.1</b>	<b>33</b>	<b>40.5</b>	<b>24</b>	<b>29.6</b>	<b>54.0</b>	<b>-24.4</b>
V	14412.000	47.8	33	40.0	24	30.8	54.0	-23.2

Polarization	Frequency (MHz)	Reading (dB $\mu$ V)	Pre-Amp Gain (dB)	Antenna Factor (dB)	Net at 3m - Peak (dB $\mu$ V/m)	Peak Limit at 3m (dB $\mu$ V/m)	Margin (dB)
H	2402.000	98.6	33	29.4	95.0	114.0	-19.0
<b>V</b>	<b>4804.000</b>	<b>63.4</b>	<b>33</b>	<b>34.9</b>	<b>65.3</b>	<b>74.0</b>	<b>-8.7</b>
V	7206.000	46.6	33	37.9	51.5	74.0	-22.5
V	9608.000	49.3	33	40.4	56.7	74.0	-17.3
<b>V</b>	<b>12010.000</b>	<b>46.1</b>	<b>33</b>	<b>40.5</b>	<b>53.6</b>	<b>74.0</b>	<b>-20.4</b>
V	14412.000	47.8	33	40.0	54.8	74.0	-19.2

- NOTES:
1. Peak detector is used for the emission measurement.
  2. All measurements were made at 3 meters. Radiated emissions not detected at the 3-meter distance were measured at 0.3-meter and an inverse proportional extrapolation was performed to compare the signal level to the 3-meter limit. No other radiated emissions than those reported were detected at a test distance of 0.3-meter.
  3. Negative value in the margin column shows emission below limit.
  4. Horn antenna is used for the emission over 1000MHz.
  5. Emission (the row indicated by **bold italic**) within the restricted band meets the requirement of FCC Part 15 Section 15.205 / RSS-210 Section 2.2.

## INTERTEK TESTING SERVICES

Mode: TX-Channel 39

Table 2, Base Unit

### Radiated Emission Data

Polarization	Frequency (MHz)	Reading (dB $\mu$ V)	Pre-Amp Gain (dB)	Antenna Factor (dB)	Average Factor (dB)	Calculated at 3m (dB $\mu$ V/m)	Average Limit at 3m (dB $\mu$ V/m)	Margin (dB)
H	2440.000	99.5	33	29.4	24	71.9	94.0	-22.1
<b>V</b>	<b>4880.000</b>	<b>63.9</b>	<b>33</b>	<b>34.9</b>	<b>24</b>	<b>41.8</b>	<b>54.0</b>	<b>-12.2</b>
<b>V</b>	<b>7320.000</b>	<b>46.5</b>	<b>33</b>	<b>37.9</b>	<b>24</b>	<b>27.4</b>	<b>54.0</b>	<b>-26.6</b>
V	9760.000	48.4	33	40.4	24	31.8	54.0	-22.2
<b>V</b>	<b>12200.000</b>	<b>46.1</b>	<b>33</b>	<b>40.5</b>	<b>24</b>	<b>29.6</b>	<b>54.0</b>	<b>-24.4</b>
V	14640.000	48.8	33	38.4	24	30.2	54.0	-23.8

Polarization	Frequency (MHz)	Reading (dB $\mu$ V)	Pre-Amp Gain (dB)	Antenna Factor (dB)	Net at 3m - Peak (dB $\mu$ V/m)	Peak Limit at 3m (dB $\mu$ V/m)	Margin (dB)
H	2440.000	99.5	33	29.4	95.9	114.0	-18.1
<b>V</b>	<b>4880.000</b>	<b>63.9</b>	<b>33</b>	<b>34.9</b>	<b>65.8</b>	<b>74.0</b>	<b>-8.2</b>
<b>V</b>	<b>7320.000</b>	<b>46.5</b>	<b>33</b>	<b>37.9</b>	<b>51.4</b>	<b>74.0</b>	<b>-22.6</b>
V	9760.000	48.4	33	40.4	55.8	74.0	-18.2
<b>V</b>	<b>12200.000</b>	<b>46.1</b>	<b>33</b>	<b>40.5</b>	<b>53.6</b>	<b>74.0</b>	<b>-20.4</b>
V	14640.000	48.8	33	38.4	54.2	74.0	-19.8

- NOTES:
1. Peak detector is used for the emission measurement.
  2. All measurements were made at 3 meters. Radiated emissions not detected at the 3-meter distance were measured at 0.3-meter and an inverse proportional extrapolation was performed to compare the signal level to the 3-meter limit. No other radiated emissions than those reported were detected at a test distance of 0.3-meter.
  3. Negative value in the margin column shows emission below limit.
  4. Horn antenna is used for the emission over 1000MHz.
  5. Emission (the row indicated by **bold italic**) within the restricted band meets the requirement of FCC Part 15 Section 15.205 / RSS-210 Section 2.2.

## INTERTEK TESTING SERVICES

---

Mode: TX-Channel 78

Table 3, Base Unit

### Radiated Emission Data

Polarization	Frequency (MHz)	Reading (dB $\mu$ V)	Pre-Amp Gain (dB)	Antenna Factor (dB)	Average Factor (dB)	Calculated at 3m (dB $\mu$ V/m)	Average Limit at 3m (dB $\mu$ V/m)	Margin (dB)
H	2480.000	99.0	33	29.4	24	71.4	94.0	-22.6
<b>V</b>	<b>4960.000</b>	<b>64.0</b>	<b>33</b>	<b>34.9</b>	<b>24</b>	<b>41.9</b>	<b>54.0</b>	<b>-12.1</b>
<b>V</b>	<b>7440.000</b>	<b>46.7</b>	<b>33</b>	<b>37.9</b>	<b>24</b>	<b>27.6</b>	<b>54.0</b>	<b>-26.4</b>
V	9920.000	48.6	33	40.4	24	32.0	54.0	-22.0
<b>V</b>	<b>12400.000</b>	<b>46.4</b>	<b>33</b>	<b>40.5</b>	<b>24</b>	<b>29.9</b>	<b>54.0</b>	<b>-24.1</b>
V	14880.000	48.9	33	38.4	24	30.3	54.0	-23.7

Polarization	Frequency (MHz)	Reading (dB $\mu$ V)	Pre-Amp Gain (dB)	Antenna Factor (dB)	Net at 3m - Peak (dB $\mu$ V/m)	Peak Limit at 3m (dB $\mu$ V/m)	Margin (dB)
H	2480.000	99.0	33	29.4	95.4	114.0	-18.6
<b>V</b>	<b>4960.000</b>	<b>64.0</b>	<b>33</b>	<b>34.9</b>	<b>65.9</b>	<b>74.0</b>	<b>-8.1</b>
<b>V</b>	<b>7440.000</b>	<b>46.7</b>	<b>33</b>	<b>37.9</b>	<b>51.6</b>	<b>74.0</b>	<b>-22.4</b>
V	9920.000	48.6	33	40.4	56.0	74.0	-18.0
<b>V</b>	<b>12400.000</b>	<b>46.4</b>	<b>33</b>	<b>40.5</b>	<b>53.9</b>	<b>74.0</b>	<b>-20.1</b>
V	14880.000	48.9	33	38.4	54.3	74.0	-19.7

- NOTES:
1. Peak detector is used for the emission measurement.
  2. All measurements were made at 3 meters. Radiated emissions not detected at the 3-meter distance were measured at 0.3-meter and an inverse proportional extrapolation was performed to compare the signal level to the 3-meter limit. No other radiated emissions than those reported were detected at a test distance of 0.3-meter.
  3. Negative value in the margin column shows emission below limit.
  4. Horn antenna is used for the emission over 1000MHz.
  5. Emission (the row indicated by **bold italic**) within the restricted band meets the requirement of FCC Part 15 Section 15.205 / RSS-210 Section 2.2.

## INTERTEK TESTING SERVICES

---

Mode: Talk with selected Bluetooth

Table 4, Base Unit

### Radiated Emission Data

Polarization	Frequency (MHz)	Reading (dB $\mu$ V)	Pre-amp (dB)	Antenna Factor (dB)	Net at 3m (dB $\mu$ V/m)	Limit at 3m (dB $\mu$ V/m)	Margin (dB)
V	31.333	30.5	16	10.0	24.5	40.0	-15.5
<b>V</b>	<b>117.421</b>	<b>26.6</b>	<b>16</b>	<b>14.0</b>	<b>24.6</b>	<b>43.5</b>	<b>-18.9</b>
V	144.460	31.1	16	14.0	29.1	43.5	-14.4
V	207.267	25.6	16	17.0	26.6	43.5	-16.9
H	310.936	20.9	16	23.0	27.9	46.0	-18.1
H	347.796	22.9	16	24.0	30.9	46.0	-15.1
H	829.401	17.3	16	31.0	32.3	46.0	-13.7
<b>H</b>	<b>962.533</b>	<b>16.0</b>	<b>16</b>	<b>33.0</b>	<b>33.0</b>	<b>54.0</b>	<b>-21.0</b>

- NOTES:
1. Peak detector is used for the emission measurement.
  2. All measurements were made at 3 meters. Radiated emissions not detected at the 3-meter distance were measured at 0.3-meter and an inverse proportional extrapolation was performed to compare the signal level to the 3-meter limit. No other radiated emissions than those reported were detected at a test distance of 0.3-meter.
  3. Negative value in the margin column shows emission below limit.
  4. Emission (the row indicated by **bold italic**) within the restricted band meets the requirement of FCC Part 15 Section 15.205 / RSS-210 Section 2.2.

---

## INTERTEK TESTING SERVICES

---

### 4.2.3 Transmitter Duty Cycle Calculation

Based on the Bluetooth Specification Version 2.0 / 2.1 + EDR, the transmitter ON time for each timeslot of Bluetooth is 625 $\mu$ s. DH5 has the maximum duty cycle, which consists of 5 continuous Tx slots and 1 Rx slot. Therefore one hopset take  $(5+1) \times 625\mu\text{s} = 3.75\text{ms}$ . For one period for a pseudo-random hopping through at least 20 RF channels in adaptive mode (worst case), it take:  $20 \times 3.75\text{ms} = 75\text{ms}$ .

The dwell time for DH5 is  $5 \times 625\mu\text{s} = 3.125\text{ms}$

For the worst case calculation, there are two transmissions might occur in 100ms.

Therefore,

$$\begin{aligned}\text{Duty Cycle (DC)} &= \text{Maximum On time in } 100\text{ms}/100\text{ms} \\ &= 3.125\text{ms} \times 2 / 100\text{ms} \\ &= 0.0625\end{aligned}$$

$$\begin{aligned}\text{Average Factor (AF) of Bluetooth in dB} &= 20 \log_{10} (0.0625) \\ &= -24.0\text{dB}\end{aligned}$$

### 4.3 Radiated Emission on the Bandedge

From the following plots, they show that the fundamental emissions are confined in the specified band (2400MHz and 2483.5MHz). In case of emissions up to two standard bandwidths away from the bandedge, the delta measurement technique is used for determining bandedge compliance. Standard bandwidth is the bandwidth specified by ANSI C63.4 (2014) for frequency being measured.

Emissions radiated outside of the specified frequency bands, except harmonics, are attenuated by 50 dB below the level of the fundamental or to the general radiated emission limits in FCC Part 15 Section 15.209 / Table 4 of RSS-Gen, whichever is the lesser attenuation, which meet the requirement of FCC Part 15 Section 15.249(d) / RSS-210 A2.9(b).

The plots of radiated emission on the bandedge are saved as below.

# INTERTEK TESTING SERVICES

## Plots of radiated emission on the bandedge

### Lowest channel

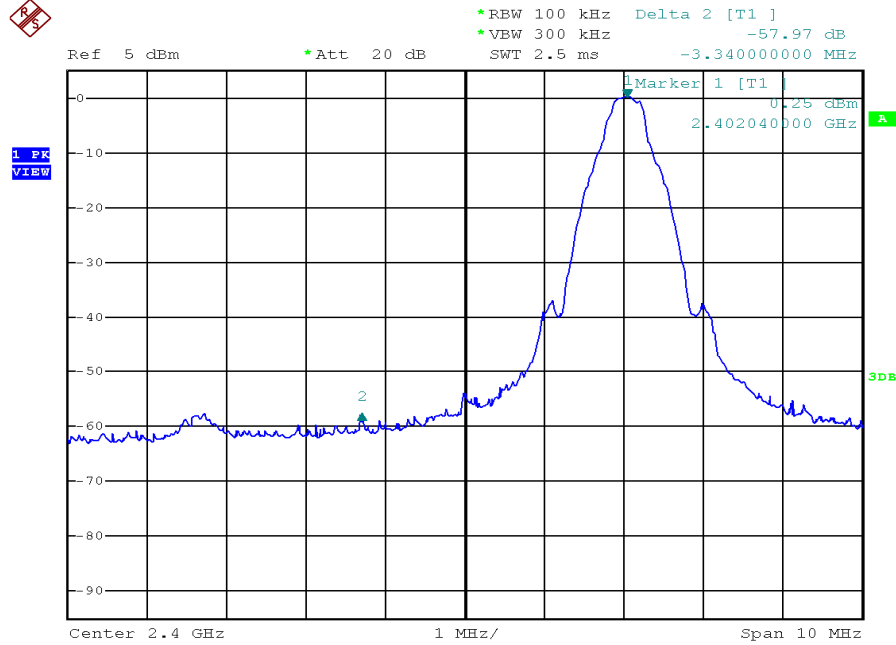

### Highest channel

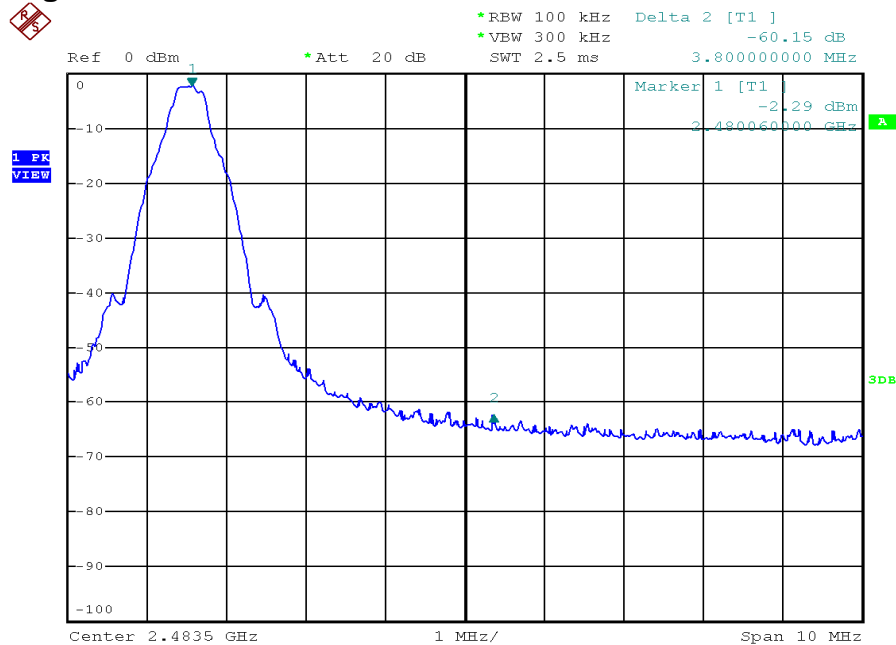

## INTERTEK TESTING SERVICES

---

Bandedge compliance is determined by applying marker-delta method, i.e.

Resultant Field Strength = Fundamental Emissions - Delta from the plot

Resultant field strength for the lowest and/or highest channel(s), with corresponding average values are calculated as follows:

AC adaptor	Channel	Fundamental Emission (dB $\mu$ V/m)	Delta from the Plot (dB)	Resultant Field Strength (dB $\mu$ V/m)	Average Limit (dB $\mu$ V/m)	Margin (dB)
Ten Pao	Lowest	71.0	57.97	13.03	54	-40.97
	Highest	71.4	60.15	11.25	54	-42.75

Ac adaptor	Channel	Fundamental Emission (dB $\mu$ V/m)	Delta from the Plot (dB)	Resultant Field Strength (dB $\mu$ V/m)	Peak Limit (dB $\mu$ V/m)	Margin (dB)
Ten Pao	Lowest	95.0	57.97	37.03	74	-36.97
	Highest	95.4	60.15	35.25	74	-38.75

The resultant field strength meets the general radiated emission limit in FCC Part 15 Section 15.209 / Table 5 of RSS-Gen, which does not exceed 74dB $\mu$ V/m for peak limit and also 54dB $\mu$ V/m for average limit.

#### **4.4 AC Power Line Conducted Emission**

- Not applicable – EUT is only powered by battery for operation.
- EUT connects to AC power line. Emission Data is listed in following pages.
- Base Unit connects to AC power line and has transmission. Handset connects to AC power line but has no transmission. Emission Data of Base Unit is listed in following pages.

Test setup is shown in section 3.4 Figure 3.4.1.

##### 4.4.1 AC Power Line Conducted Emission Configuration Photograph

Worst Case Line-Conducted Configuration  
at

343.5 kHz

The worst case line conducted configuration photographs are saved with filename: config photos.pdf.

##### 4.4.2 AC Power Line Conducted Emission Data

The plot(s) and data in the following pages list the significant emission frequencies, the limit and the margin of compliance.

Passed by 15.15 dB margin compared with average limit

# INTERTEK TESTING SERVICES

Worst Case: Talk with selected Bluetooth

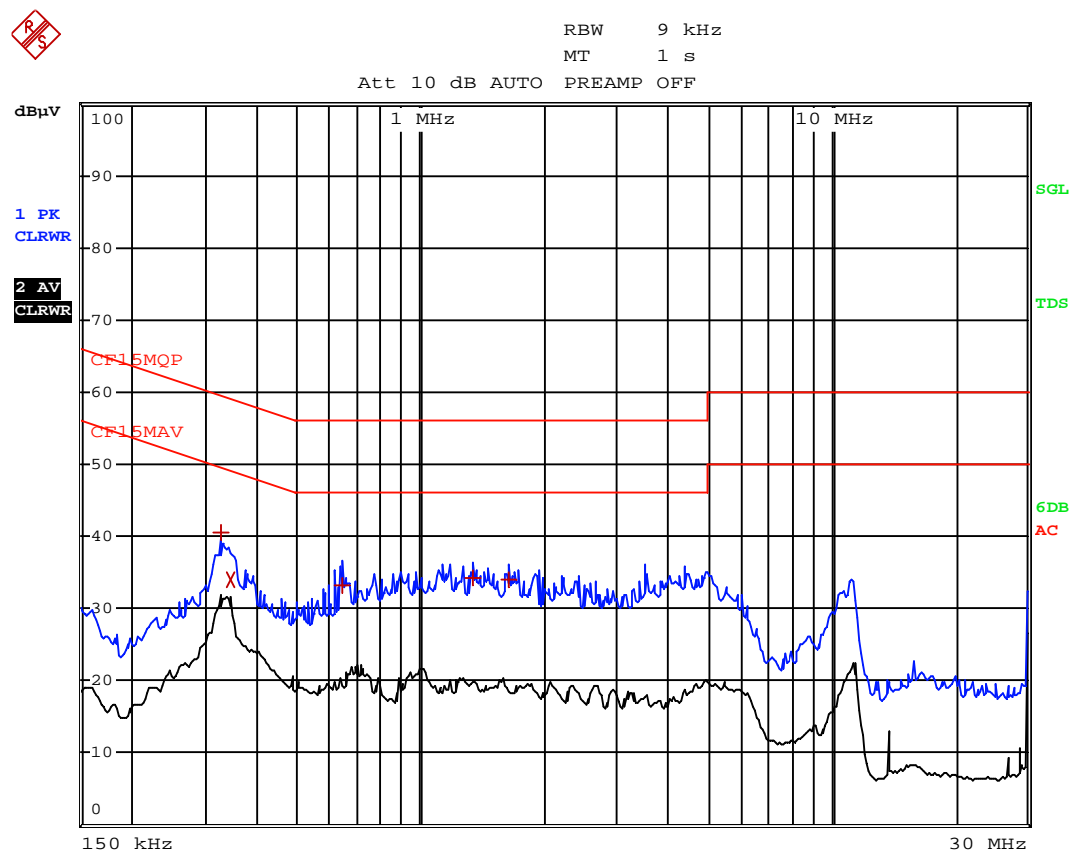

# INTERTEK TESTING SERVICES

---

Worst Case: Talk with selected Bluetooth

EDIT PEAK LIST (Final Measurement Results)					
Trace1: CF15MQP					
Trace2: CF15MAV					
Trace3: ---					
	TRACE	FREQUENCY	LEVEL	dB $\mu$ V	DELTA LIMIT dB
1	Quasi Peak	325.5 kHz	40.47	N	-19.08
2	CISPR Average	343.5 kHz	33.95	N	-15.15
1	Quasi Peak	640.5 kHz	33.16	N	-22.83
1	Quasi Peak	1.3335 MHz	34.29	N	-21.71
1	Quasi Peak	1.6485 MHz	33.86	N	-22.13

**INTERTEK TESTING SERVICES**

---

**EXHIBIT 5  
EQUIPMENT LIST**

## INTERTEK TESTING SERVICES

---

### 5.0 Equipment List

#### 1) Radiated Emissions Test

Equipment	BiConiLog Antenna	Double Ridged Guide Antenna	Broad-Band Horn Antenna
Registration No.	EW-3061	EW-1133	EW-1679
Manufacturer	EMCO	EMCO	SCHWARZBECK
Model No.	3412E	3115	BBHA9170
Calibration Date	Jul. 22, 2015	Nov. 5, 2015	Jun. 10, 2015
Calibration Due Date	Jul. 22, 2016	May. 5, 2017	Jun. 10, 2016

Equipment	EMI Test Receiver	Spectrum Analyzer
Registration No.	EW-3156	EW-2253
Manufacturer	R&S	R&S
Model No.	ESR26	FSP40
Calibration Date	Nov. 3, 2015	May. 27, 2015
Calibration Due Date	Nov. 3, 2016	May. 27, 2016

#### 2) Conducted Emissions Test

Equipment	EMI Test Receiver	LISN
Registration No.	EW-3095	EW-2501
Manufacturer	R&S	R&S
Model No.	ESCI	ENV-216
Calibration Date	Nov 5, 2015	Jan 28, 2016
Calibration Due Date	Nov 5, 2016	Jan 28, 2017

#### 3) Bandedge Measurement Test

Equipment	Spectrum Analyzer
Registration No.	EW-2253
Manufacturer	R&S
Model No.	FSP40
Calibration Date	May. 27, 2015
Calibration Due Date	May. 27, 2016

**END OF TEST REPORT**