

47 CFR FCC Part 15 Subpart C

Section 15.247

Test Report

Product : Transceiver

Trade Name : N/A

Model Number : CAIVU-LR; SLIVU-LR

FCC ID : ELMTRUF

Prepared for

Nutek Corporation

No.167, Lane 235, Bauchiau Rd., Xindian District,
New Taipei City 23145, Taiwan

TEL. : +886 2 2918 9478

FAX. : +886 2 2917 9069

Prepared by

Interocean EMC Technology Corp.

Interocean EMC Technology Tin-Fu Laboratory

No. 5-2, Lin 1, Tin-Fu, Lin-Kou Dist., New Taipei City,
Taiwan 244, R.O.C.

TEL.: +886 2 2600 6861

FAX.: +886 2 2600 6859



Remark:

The test report consists of **34** pages in total. It shall not be reproduced except in full, without the written approval of IETC. This document may be altered or revised by IETC only, and shall be noted in the revision section of the document.

The test result in this report is only subjected to the test sample.

Table of Contents

1	General Information	5
1.1	Description of Equipment Under Test	5
1.2	Test Facility	6
1.3	Test Equipment	7
1.4	Measurement Uncertainty	7
1.5	Duty Cycle	8
1.6	Summary of Measurement	8
1.7	Test Step of EUT	9
2	RF radiated spurious emission test	10
2.1	Limit	10
2.2	Configuration of Measurement	10
2.3	Test Procedure	11
2.4	Test Result	11
3	RF Conducted spurious emission	16
3.1	Limit	16
3.2	Configuration of Measurement	16
3.3	Test Procedure	16
3.4	Test Result	16
4	Maximum peak output power test	18
4.1	Limit	18
4.2	Configuration of Measurement	18
4.3	Test Procedure	18
4.4	Test Result	18
5	6dB Bandwidth	21
5.1	Limit	21
5.2	Configuration of Measurement	21
5.3	Test Procedure	21
5.4	Test Result	21
6	Power spectral density	23
6.1	Limit	23
6.2	Configuration of Measurement	23
6.3	Test Procedure	23
6.4	Test Result	23
7	Emission on the Band Edge test	25
7.1	Limit	25
7.2	Configuration of Measurement	25
7.3	Test Procedure	25
7.4	Test Result	25

8	Photographs of Test	29
8.1	Radiated Emission Measurement (Below 1 GHz)	29
8.2	Radiated Emission Measurement (Above 1 GHz)	29
9	Photographs of EUT	30
9.1	Model No.: CAIVU-LR	30

Statement of Compliance

Applicant: Nutek Corporation
Manufacturer: Nutek Corporation
Product: Transceiver
Model No.: CAIVU-LR; SLIVU-LR
Tested Power Voltage: DC 5V
Date of Final Test: May 28, 2021
Revision of Report: Rev. 01

Configuration of Measurements and Standards Used :

FCC Rules and Regulations Part 15 Subpart C Section 15.247

I HEREBY CERTIFY THAT: The data shown in this report were made in accordance with the procedures given in ANSI C63.10, and the energy emitted by the device was founded to be within the limits applicable. I assume full responsibility for accuracy and completeness of these data.

- Note:**
1. The result of the testing report relate only to the item tested.
 2. This report shall not be partial reproduced without written approval by Interocean EMC Technology Corporation.
 3. Judgment of conformity is based on test result, regardless of measurement uncertainty.

Report Issued: 2021/06/11

Prepared by: Ivan Wang
Ivan Wang

Approved: Jerry Chang
Jerry Chang

1 General Information

1.1 Description of Equipment Under Test

Product	: Transceiver
Model Number	: CAIVU-LR; SLIVU-LR
Applicant	: Nutek Corporation No.167, Lane 235, Bauchiau Rd., Xindian District, New Taipei City 23145, Taiwan
Manufacturer	: Nutek Corporation No.167, Lane 235, Bauchiau Rd., Xindian District, New Taipei City 23145, Taiwan
Power Supply	: DC 5V
Operating Frequency	: 909.6 MHz
Output Power	: 13.35 dBm
Channel Number	: 1 channel
Type of Modulation	: LoRa
Antenna Description	: PCB Antenna. maximum Peak gain: 0dBi.
Measurement Software	: e3; Ver: 8.120803a7-2
Receipt Date of EUT	: Apr. 09, 2021
Date of Test	: Apr. 21 ~ May 28, 2021
Additional Description	: 1) The test model is “ CAIVU-LR ”, designated by the applicant and included in this report. 2) The differences of all models included in this report are provided by the applicant, and the lab disclaims any liability related to reporting, if incorrect, from such provision. The difference of all models is only for different market. 3) For more detailed specification about EUT, please refer to the user’s manual.

1.2 Test Facility

- Site Description** : ☒ Chamber 3
- Name of Firm** : Interocean EMC Technology Corp.
- Company web** : <http://www.ietc.com.tw>
- Location** : No. 5-2, Lin 1, Tin-Fu, Lin-Kou Dist., New Taipei City, Taiwan 244, R.O.C.
- Site Filing** :
- Federal Communication Commissions – USA
Designation No.: TW1020 (Test Firm Registration #: 651092)
Designation No.: TW1113 (Test Firm Registration #: 959554)
 - Innovation, Science and Economic Development Canada (ISED)
CAB identifier: TW1113 (Ref. No 14962756)
 - Voluntary Control Council for Interference by Information Technology Equipment (VCCI) – Japan
Member No.: 1349
Registration No. (Conducted Room): C-11094
Registration No. (Conducted Room): T-11562
Registration No. (OATS 1): R-11040
Registration No. (Chamber 3): G-20080
- Site Accreditation** :
- Bureau of Standards and Metrology and Inspection (BSMI) – Taiwan, R.O.C.
Accreditation No.:
SL2-IN-E-0026 for CNS 13438 / CISPR 22
SL2-R1-E-0026 for CNS 13439 / CISPR 13
SL2-R2-E-0026 for CNS 13439 / CISPR 13
SL2-L1-E-0026 for CNS 14115 / CISPR 15
 - Taiwan Accreditation Foundation (TAF)
Accreditation No.: 1113
 - American Association for Laboratory Accreditation (A2LA)
Certificate Number: 4891.01
 - Vehicle Safety Certification Center (VSCC)
Approval No.: TW16-11

1.3 Test Equipment

Instrument	Manufacturer	Model	Serial No.	Next Cal. Date
Spectrum Analyzer	R&S	FSP40	100478	2021/07/28
Loop Antenna	Electro-Metrics	EM-6879	261	2021/09/16
Bilog Antenna	ETC	MCTD 2786B	BLB17S04020	2021/05/04
Horn Antenna	Schwarzbeck	BBHA9120	9120D-1051	2021/08/03
Pre-Amplifier	EMCI	EMC001150	980130	2021/08/02
Pre-Amplifier	EMCI	EMC051845	980110	2021/07/02
RF Cable	HARBOUR	27478LL142	CBL65	2021/07/28
RF Cable	Marvelous Microwave	MCBL-LL266.50	CBL70	2021/07/28
Measurement Software	AUDIX-e3			

Note: The above equipments are within the valid calibration period.

1.4 Measurement Uncertainty

Item	Value
Chamber 3:	
Radiated Emission Test (9 kHz to 30 MHz)	3.2 dB
Radiated Emission Test (30 MHz to 200 MHz)	4.6 dB
Radiated Emission Test (200 MHz to 1 GHz) (Antenna: without tilting)	5.9 dB
Radiated Emission Test (1 GHz to 18 GHz)	5.0 dB
Radiated Emission Test (18 GHz to 40 GHz)	5.4 dB
The reported expanded uncertainty is based on a standard uncertainty multiplied by a coverage factor of k=2, providing a level of confidence of approximately 95%	

1.5 Duty Cycle

According to KDB 558074 D01 15.247 Meas Guidance v05:

All measurements are to be performed with the EUT transmitting at 100% duty cycle at its maximum power control level; however, if 100% duty cycle cannot be achieved, measurements of duty cycle, x, and maximum power transmission duration, T, are required for each tested mode of operation.

Configuration	On Time (ms)	Period (ms)	Duty Cycle (%)	Duty Factor (dB)
LoRa	132.85	300.85	44.16	3.55

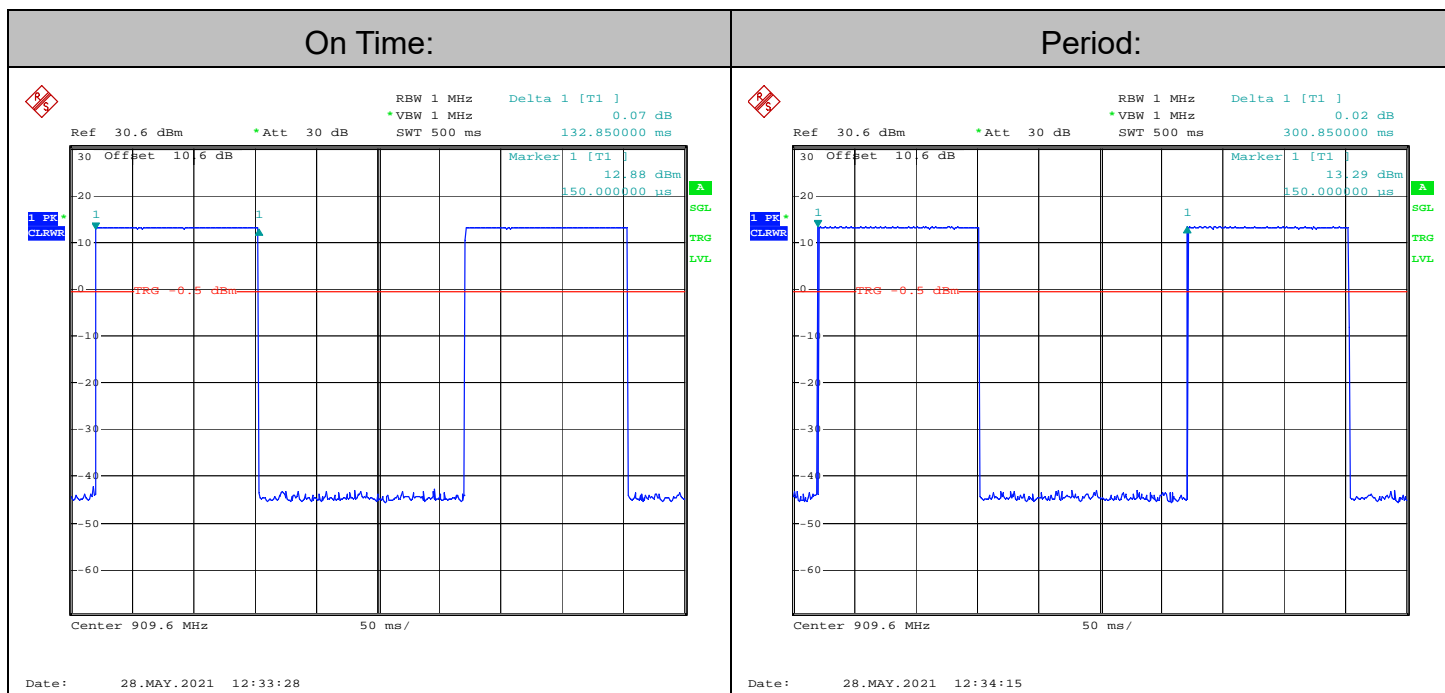

1.6 Summary of Measurement

Report Clause	Test Parameter	Reference Document 47 CFR Part15	Results
2	RF Radiated spurious emission test	§15.205, 15.209	Pass
3	RF Conducted spurious emission	§15.247(d)	Pass
4	Maximum Peak output power test	§15.247(b)	Pass
5	6dB Bandwidth	§15.247(a)(2)	Pass
6	Power spectral density	§15.247(e)	Pass
7	Emission on the Band Edge	§15.247(d)	Pass
	AC Power Line Conducted Emission test	§15.207	N/A

1.7 Test Step of EUT

- 1.7.1 Set the fixture to EUT for power supplying.
- 1.7.2 Turn on the power of all equipments.
- 1.7.3 Let the EUT continuous transmission.
- 1.7.4 Execute the test.

2 RF radiated spurious emission test

2.1 Limit

For intentional radiator, the radiated emission shall comply with §15.209(a).

For intentional radiators, according to §15.247 (a), operation under this provision is limited to frequency hopping and direct sequence spread spectrum, and the out band emission shall be comply with §15.247 (d)

Frequency (MHz)	Field strength dB(μ V/m)	Measurement distance (meters)
1.705 - 30.0	29.5	30
30 - 88	40	3
88 - 216	43.5	3
216 - 960	46	3
Above 960	54	3

2.2 Configuration of Measurement

Measurement Frequency under 1 GHz

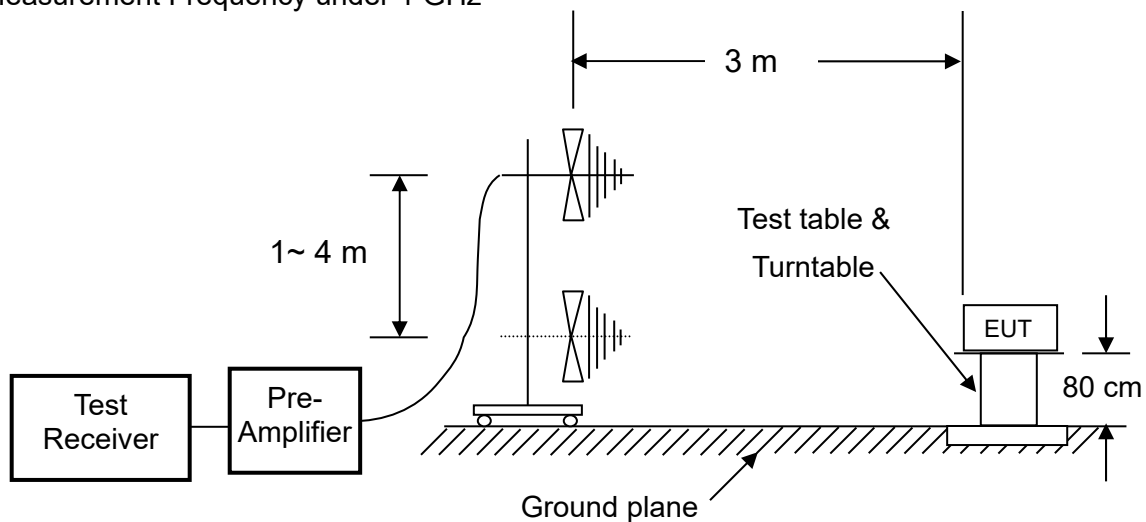

Measurement Frequency above 1 GHz

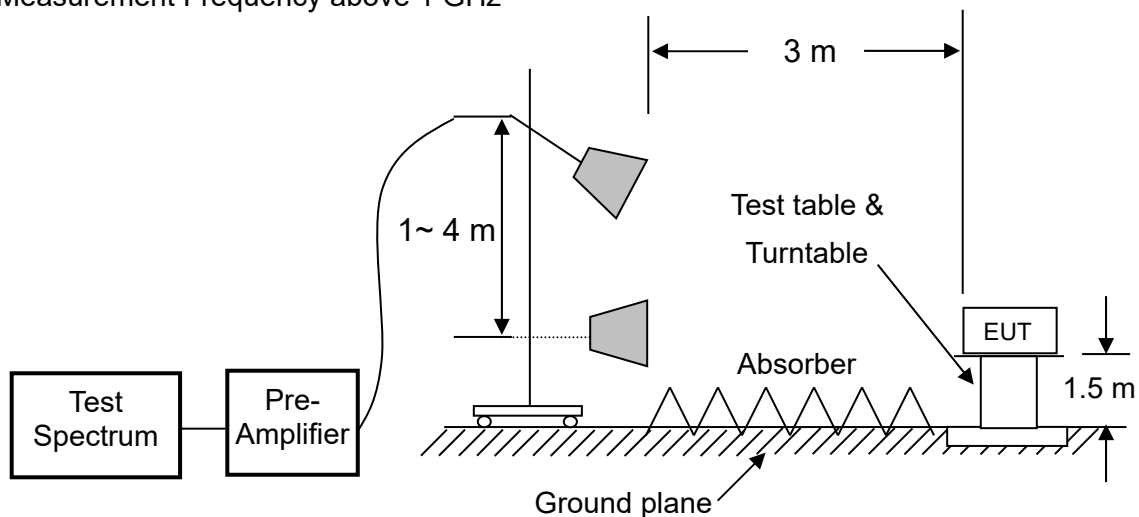

2.3 Test Procedure

The EUT was setup to ANSI C63.10, 2013; tested to DTS test procedure of August 24, 2018 KDB558074 D01 for compliance to FCC 47CFR 15.247 requirements.

Radiated emission measurements were performed from 30 MHz to 25 GHz. Spectrum Analyzer set as below: For frequency range from 30 MHz to 1 GHz: RBW=100 kHz or greater. For frequencies above 1 GHz: set RBW=VBW=1 MHz for peak detector and RBW=1 MHz, VBW=10 Hz for average detector.

The EUT for testing is arranged on a turntable. If some peripherals apply to the EUT, the peripherals will be connected to EUT and the whole system. During the test, all cables were arranged to produce worst-case emissions. The signal is maximized through rotation. The height of antenna and polarization is changing constantly for exploring for maximum signal level. The height of antenna can be up to 4 meter and down to 1 meter.

The frequency range from 9 kHz to 30 MHz was pre-scanned and the results was 20 dB lower than the limit line which according to FCC 15.31(o) needs not be recorded.

2.4 Test Result

PASS.

The final test data is shown on as following pages.

Radiated spurious emission

Radiated Emission Below 1 GHz

CLIENT: Nutek Corporation

EUT: Transceiver

MODEL: CAIVU-LR

RATING: DC 5V

COMMENT:

Data:270

OPERATOR : Scott

TEST SITE : Chamber 3

TEST DISTANCE : 3 m

POLARIZATION : HORIZONTAL

TEMP/HUM : 25.2°C/42%

2021-04-21

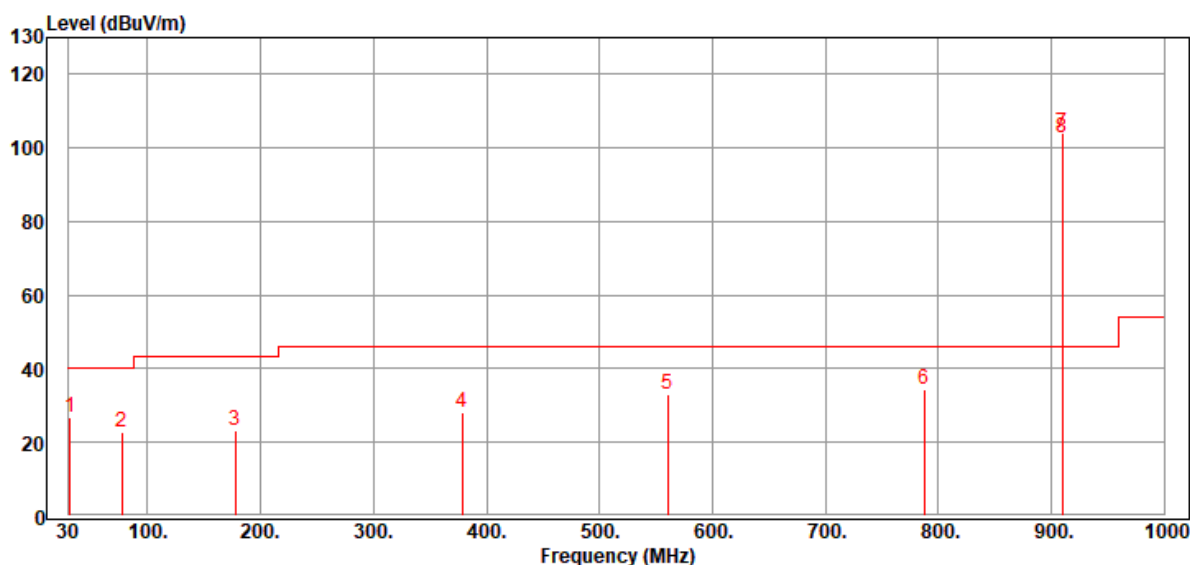

Item Mark	Freq. MHz	Reading dBuV	Factor dB/m	Level dBuV/m	Limit dBuV/m	Margin dB	Remark	
1	31.250	58.21	-31.27	26.94	40.00	-13.06	Peak	
2	77.360	61.36	-38.71	22.65	40.00	-17.35	Peak	
3	177.360	58.66	-35.22	23.44	43.50	-20.06	Peak	
4	378.550	56.32	-28.06	28.26	46.00	-17.74	Peak	
5	560.780	59.39	-26.12	33.27	46.00	-12.73	Peak	
6	787.440	57.22	-22.68	34.54	46.00	-11.46	Peak	
*	7	909.610	124.71	-20.46	104.25	46.00	58.25	Peak
*	8	909.610	123.25	-20.46	102.79	46.00	56.79	Average

Remark : Corrected Level = Reading + Correction Factor – Preamp
 Correction Factor = Antenna Factor + Cable Loss
 Margin = Corrected Level – Limits

CLIENT: Nutek Corporation
 EUT: Transceiver
 MODEL: CAIVU-LR
 RATING: DC 5V
 COMMENT:
 Data:269

OPERATOR : Scott
 TEST SITE : Chamber 3
 TEST DISTANCE : 3 m
 POLARIZATION : VERTICAL
 TEMP/HUM : 25.2°C/42%
 2021-04-21

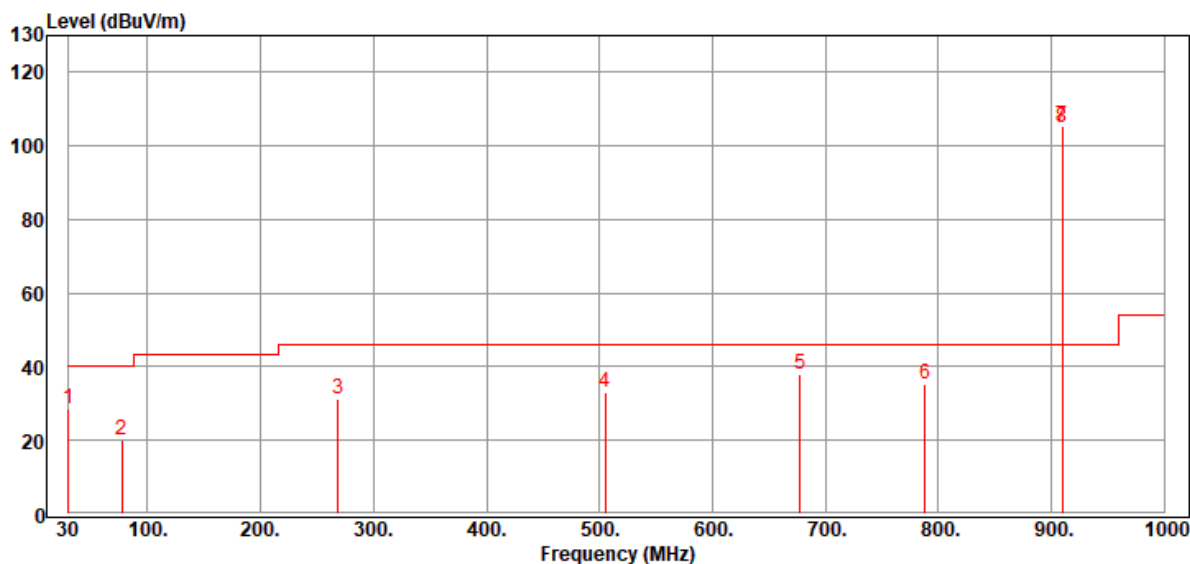

Item Mark	Freq. MHz	Reading dBuV	Factor dB/m	Level dBuV/m	Limit dBuV/m	Margin dB	Remark	
1	30.010	59.38	-30.97	28.41	40.00	-11.59	Peak	
2	77.220	58.68	-38.73	19.95	40.00	-20.05	Peak	
3	268.360	62.11	-30.77	31.34	46.00	-14.66	Peak	
4	504.930	59.38	-26.30	33.08	46.00	-12.92	Peak	
5	677.360	62.38	-24.55	37.83	46.00	-8.17	Peak	
6	788.150	58.02	-22.65	35.37	46.00	-10.63	Peak	
*	7	909.610	126.03	-20.46	105.57	46.00	59.57	Peak
*	8	909.610	125.25	-20.46	104.79	46.00	58.79	Average

Remark : Corrected Level = Reading + Correction Factor – Preamp
 Correction Factor = Antenna Factor + Cable Loss
 Margin = Corrected Level – Limits

Radiated Emission Above 1 GHz

CLIENT: Nutek Corporation

EUT: Transceiver

MODEL: CAIVU-LR

RATING: DC 5V

COMMENT:

Data:259

OPERATOR : Scott

TEST SITE : Chamber 3

TEST DISTANCE : 3 m

POLARIZATION : HORIZONTAL

TEMP/HUM : 25.2°C/42%

2021-05-21

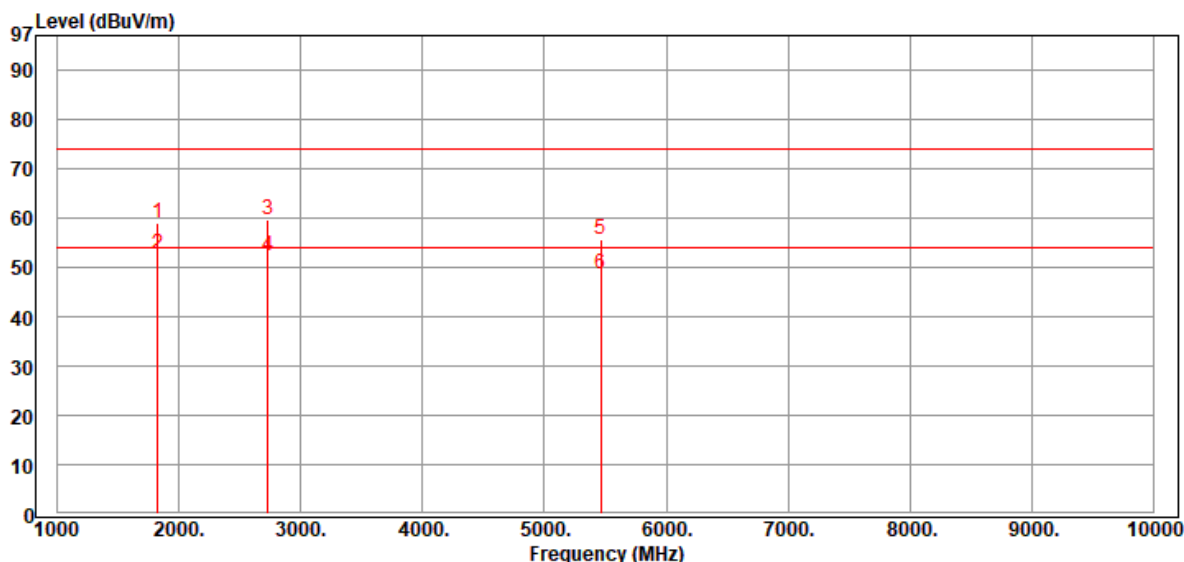

Item Mark	Freq. MHz	Reading dBuV	Factor dB/m	Level dBuV/m	Limit dBuV/m	Margin dB	Remark
1	1820.000	78.54	-19.48	59.06	74.00	-14.94	Peak
2	1820.000	72.16	-19.48	52.68	54.00	-1.32	Average
3	2725.000	74.69	-15.09	59.60	74.00	-14.40	Peak
4	2725.000	67.55	-15.09	52.46	54.00	-1.54	Average
5	5460.000	63.90	-8.08	55.82	74.00	-18.18	Peak
6	5460.000	56.61	-8.08	48.53	54.00	-5.47	Average

Remark: Corrected Level = Reading + Correction Factor - Preamp

Correction Factor = Antenna Factor + Cable Loss

Margin = Corrected Level – Limits

Measuring frequencies from 1 GHz to the 10th harmonic of highest fundamental frequency.

Measurements above show only up to 6 maximum emissions noted, or would be lesser if no specific emissions from the EUT are recorded (ie: margin > 20dB from the applicable limit) and considered that's already beyond the background noise floor.

CLIENT: Nutek Corporation
 EUT: Transceiver
 MODEL: CAIVU-LR
 RATING: DC 5V
 COMMENT:
 Data:260

OPERATOR : Scott
 TEST SITE : Chamber 3
 TEST DISTANCE : 3 m
 POLARIZATION : VERTICAL
 TEMP/HUM : 25.2°C/42%
 2021-05-21

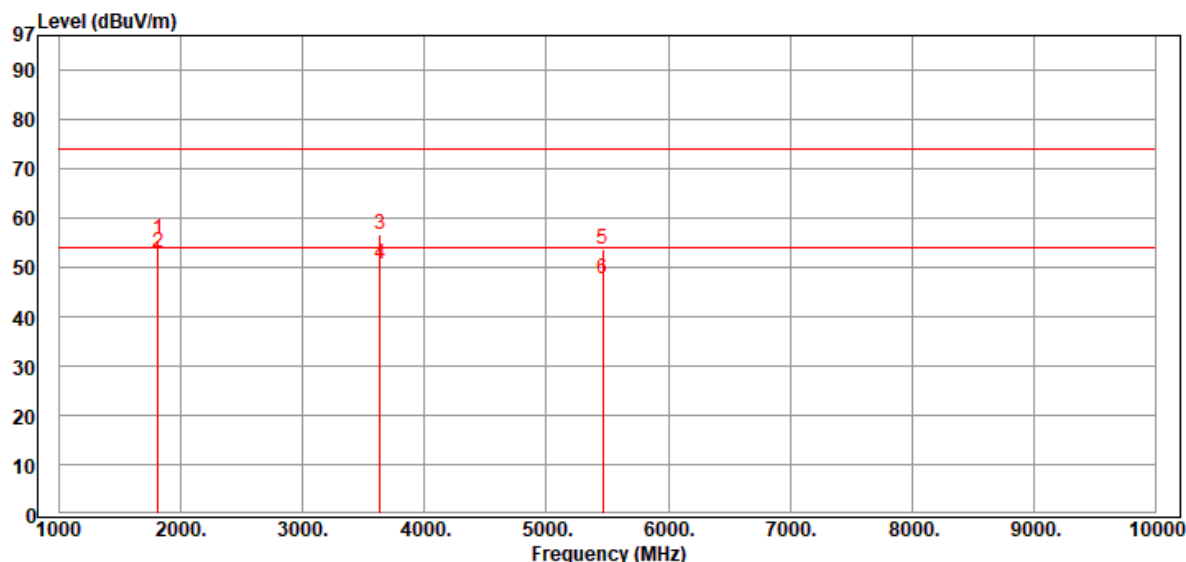

Item Mark	Freq. MHz	Reading dBuV	Factor dB/m	Level dBuV/m	Limit dBuV/m	Margin dB	Remark
1	1810.000	75.26	-19.52	55.74	74.00	-18.26	Peak
2	1810.000	72.65	-19.52	53.13	54.00	-0.87	Average
3	3635.000	69.43	-12.87	56.56	74.00	-17.44	Peak
4	3635.000	63.50	-12.87	50.63	54.00	-3.37	Average
5	5460.000	61.75	-8.08	53.67	74.00	-20.33	Peak
6	5460.000	55.61	-8.08	47.53	54.00	-6.47	Average

Remark: Corrected Level = Reading + Correction Factor - Preamp

Correction Factor = Antenna Factor + Cable Loss

Margin = Corrected Level – Limits

Measuring frequencies from 1 GHz to the 10th harmonic of highest fundamental frequency.

Measurements above show only up to 6 maximum emissions noted, or would be lesser if no specific emissions from the EUT are recorded (ie: margin > 20dB from the applicable limit) and considered that's already beyond the background noise floor.

3 RF Conducted spurious emission

3.1 Limit

According to 15.247(d) requirement :

In any 100 kHz bandwidth outside the frequency band in which the spread spectrum or digitally modulated intentional radiator is operating, the radio frequency power that is produced by the intentional radiator shall be at least 20 dB below that in the 100 kHz bandwidth within the band that contains the highest level of the desired power, based on either an RF conducted or a radiated measurement, provided the transmitter demonstrates compliance with the peak conducted power limits.

3.2 Configuration of Measurement

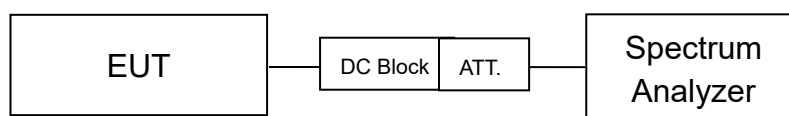

3.3 Test Procedure

The EUT was setup to ANSI C63.10, 2013; tested to DTS test procedure of August 24, 2018 KDB558074 D01 for compliance to FCC 47CFR 15.247 requirements.

The measurements were performed from 30MHz to 25GHz RF antenna conducted per FCC 15.247 (c) was measured from the EUT antenna port using a 50ohm spectrum analyzer with the resolution bandwidth set at 100 kHz, and the video bandwidth set \geq RBW.

Harmonics and spurious noise must be at least 20dB down from the highest emission level within the authorized band as measured with a 100 kHz RBW. The table below is the results from the highest emission for each channel within the authorized band. This table was used to determine the spurious limit for each channel.

3.4 Test Result

PASS.

Conducted spurious emission

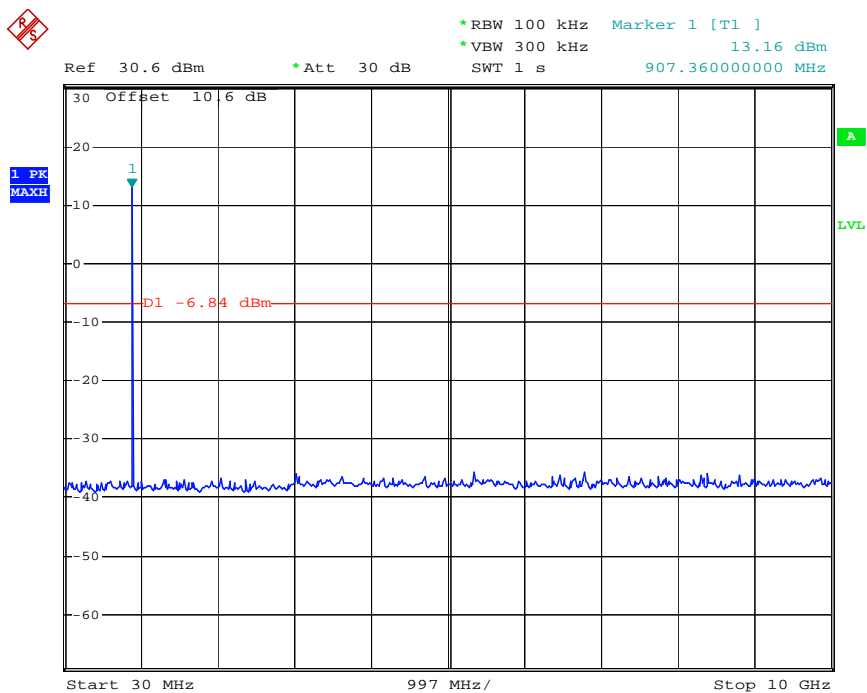

Date: 28.MAY.2021 12:41:19

4 Maximum peak output power test

4.1 Limit

According to FCC Part15.247 (b)(3) requirement :

For systems using digital modulation in the 902–928 MHz bands: The maximum conducted output power shall be less than 1Watt.

4.2 Configuration of Measurement

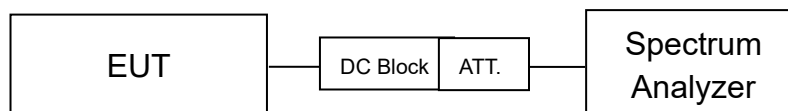

4.3 Test Procedure

The EUT was setup to ANSI C63.10, 2013; tested to DTS test procedure of August 24, 2018 KDB558074 D01 for compliance to FCC 47CFR 15.247 requirements.

For FCC §15.247(b) the power output was measured on the EUT using a 50 ohm SMA cable connected to Spectrum Analyzer. Peak output power was read directly from Spectrum Analyzer.

Set :

- (1) $RBW \geq$ DTS bandwidth, $VBW \geq 3 \times RBW$
- (2) $Span \geq 3 \times EBW$
- (3) Detector = peak, trace mode = max hold
- (4) All trace to fully stabilize
- (5) Use peak marker function to determine the peak amplitude

4.4 Test Result

PASS.

The final test data is shown on as following pages.

Remark:

1. Output power = Reading + factor
2. Margin = Output power - Limit

Maximum output power

Freq. (MHz)	Output Power (dBm)	Output Power (mW)	LIMIT (dBm)	Magrin (dB)
909.6	13.35	21.63	30	-16.65

Plot:

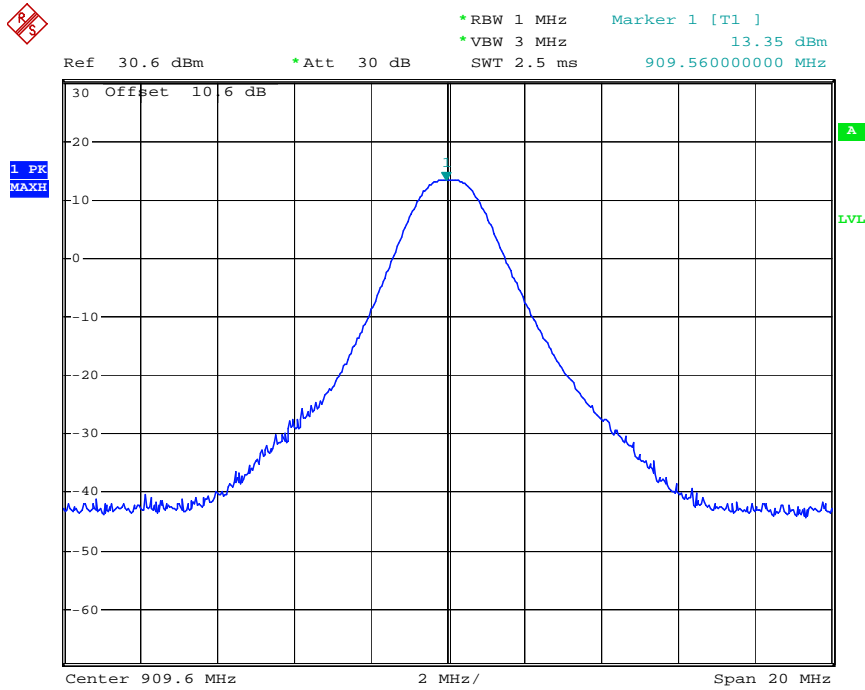

Date: 28.MAY.2021 12:43:39

Maximum Average power

Duty cycle factor in dB = $20 \log (\text{duty cycle}) = 20 \log (T_{on}/T_p)$

The duration of one cycle = 132.85ms

The transmission time of one cycle = 300.85ms

Duty Cycle = $129.0 \text{ ms} / 304.0\text{ms} = 0.44158$

Therefore, the duty cycle factor is found by $20 \log 0.442434 = -7.10 \text{ dB}$

Freq. (MHz)	Output Power (dBm)	Duty Factor (dB)	Average Power (dBm)	Average Power (mW)	LIMIT (dBm)	Margin (dB)
909.6	13.35	-7.10	6.25	4.217	30	-23.75

5 6dB Bandwidth

5.1 Limit

According to FCC Part15.247 (a)(2) requirement :

Systems using digital modulation techniques may operate in the 902–928 MHz, The minimum 6dB bandwidth shall be at least 500 kHz.

5.2 Configuration of Measurement

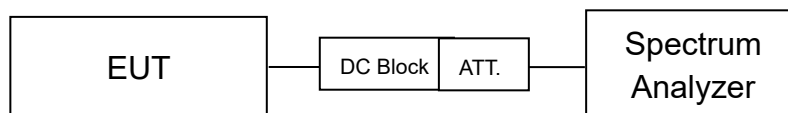

5.3 Test Procedure

The minimum 6dB bandwidth was measured using a 50 ohm spectrum analyzer.

- (1) RBW = 30 kHz
- (2) VBW \geq 3 x RBW
- (3) Detector = Peak
- (4) Trace mode = Max hold
- (5) Sweep = auto couple
- (6) All trace to fully stabilize
- (7) Measure the maximum width of the emission that is constrained by the frequencies associated with the two outermost amplitude points (upper and lower frequencies) that are attenuated by 6dB relative to the maximum level measured in the fundamental emission.

5.4 Test Result

PASS.

The final test data is shown on as following pages.

6dB bandwidth

Freq. (MHz)	6dB Bandwidth (kHz)	LIMIT (kHz)	Result
909.6	544.00	>500	PASS

Plot:

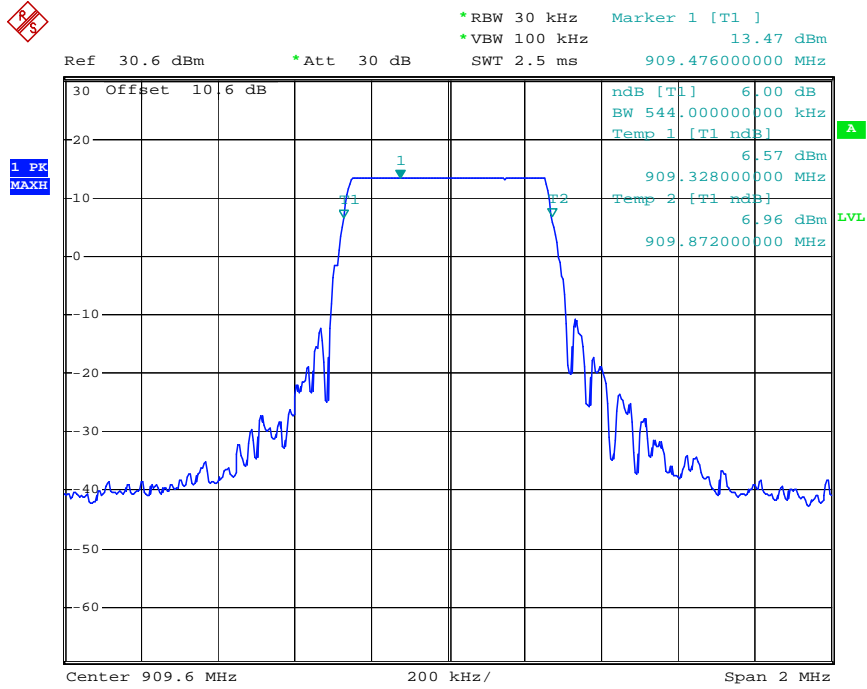

Date: 28.MAY.2021 12:37:17

6 Power spectral density

6.1 Limit

According to FCC Part15.247 (e) requirement :

For digitally modulated systems, the power spectral density conducted from the intentional radiator to the antenna shall not be greater than 8 dBm in any 3 kHz band during any time interval of continuous transmission.

6.2 Configuration of Measurement

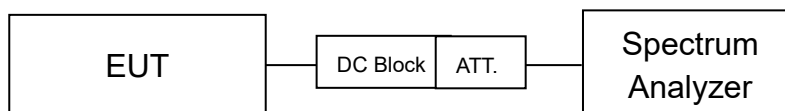

6.3 Test Procedure

The EUT was setup to ANSI C63.10, 2013; tested to DTS test procedure of August 24, 2018 KDB558074 D01 for compliance to FCC 47CFR 15.247 requirements.

Set::

- (1) Analyzer center frequency to DTS channel center frequency
- (2) The span to 1.5 times the DTS bandwidth
- (3) RBW: $3\text{kHz} \leq \text{RBW} \leq 100\text{kHz}$
- (4) VBW $\geq 3 \times \text{RBW}$
- (5) Detector = Peak
- (6) Trace mode = Max hold
- (7) Sweep = auto couple
- (8) All trace to fully stabilize
- (9) Use the peak marker function to determine the maximum amplitude level within the RBW
- (10) If measured value exceeds limit, reduce RBW (no less than 3kHz) and repeat

6.4 Test Result

PASS.

The final test data is shown on as following pages.

Remark:

1. PSD = Reading + factor
2. Margin = Output power – Limit

Power spectral density

Freq. (MHz)	PSD (dBm/3kHz)	LIMIT (dBm/3kHz)	Result
909.6	6.53	8	PASS

Plot:

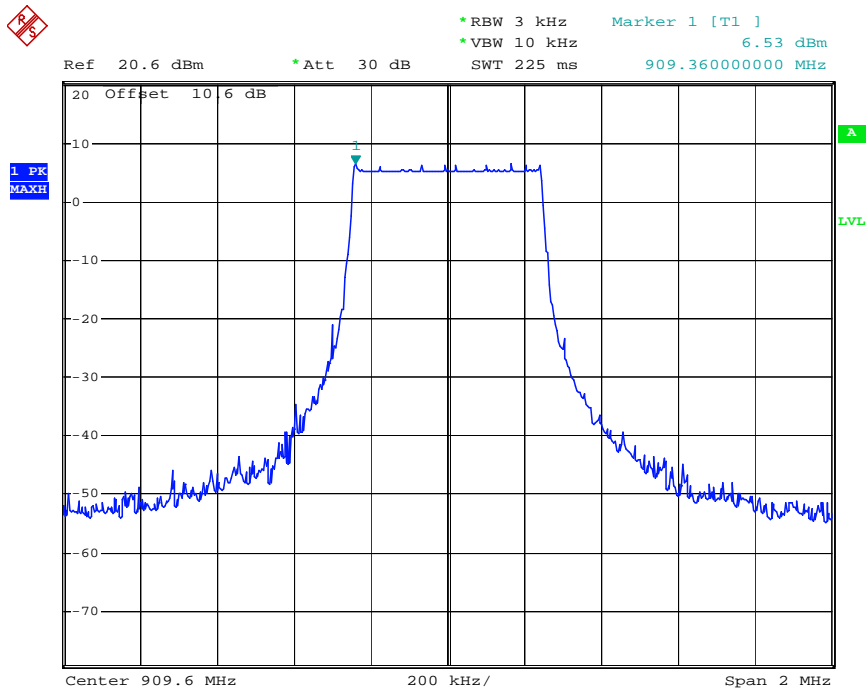

Date: 28.MAY.2021 12:28:02

7 Emission on the Band Edge test

7.1 Limit

In any 100 kHz bandwidth outside the frequency band in which the spread spectrum intentional radiator is operating, the radio frequency power that is produced by the intentional radiator shall be at least 20 dB below that in the 100 KHz bandwidth within the band that contains the highest level of the desired power, based on either an RF conducted or a radiated measurement.

7.2 Configuration of Measurement

Radiated measurement

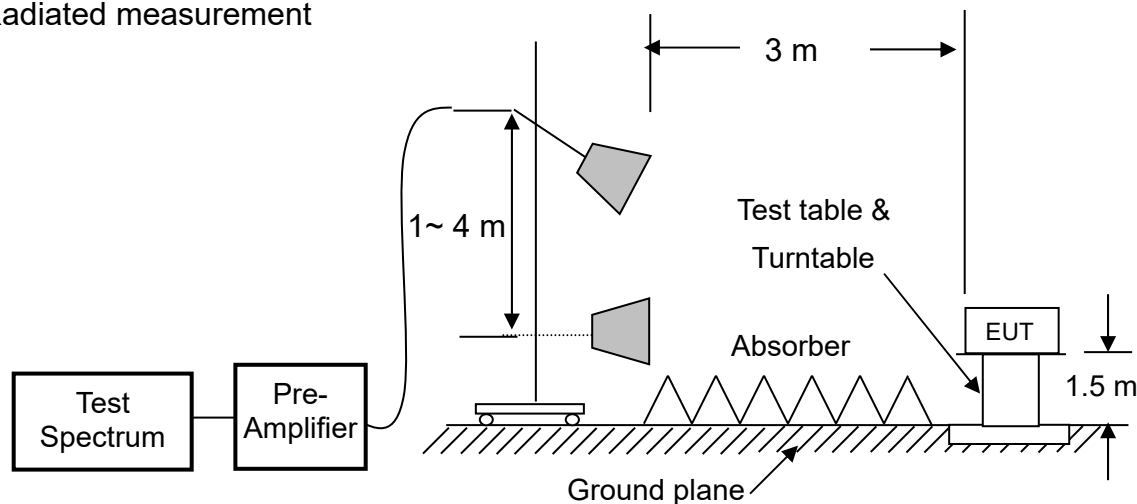

Conducted measurement

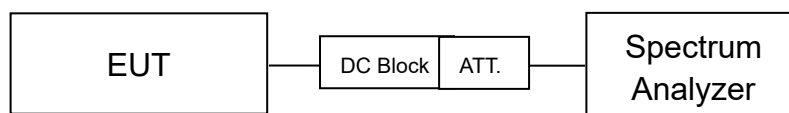

7.3 Test Procedure

The EUT was setup to ANSI C63.10, 2013; tested to DTS test procedure of August 24, 2018 KDB558074 D01 for compliance to FCC 47CFR 15.247 requirements.

Set RBW =1MHz, VBW= RBW for peak, and RBW =1MHz, VBW=10Hz for average.

The EUT for testing is arranged on a wooden turntable. If some peripherals apply to the EUT, the peripherals will be connected to EUT and the whole system. During the test, all cables were arranged to produce worst-case emissions. The signal is maximized through rotation. The height of antenna and polarization is changing constantly for exploring for maximum signal level. The height of antenna can be up to 4 meter and down to 1 meter.

7.4 Test Result

PASS.

The final test data is shown on as following pages.

Band-edge_Radiated

CLIENT: Nutek Corporation
 EUT: Transceiver
 MODEL: CAIVU-LR
 RATING: DC 5V
 COMMENT: bandedge

OPERATOR : Scott
 TEST SITE : Chamber 3
 TEST DISTANCE : 3 m
 POLARIZATION : HORIZONTAL
 TEMP/HUM : 25.2°C/42%

Data:271

2021-04-21

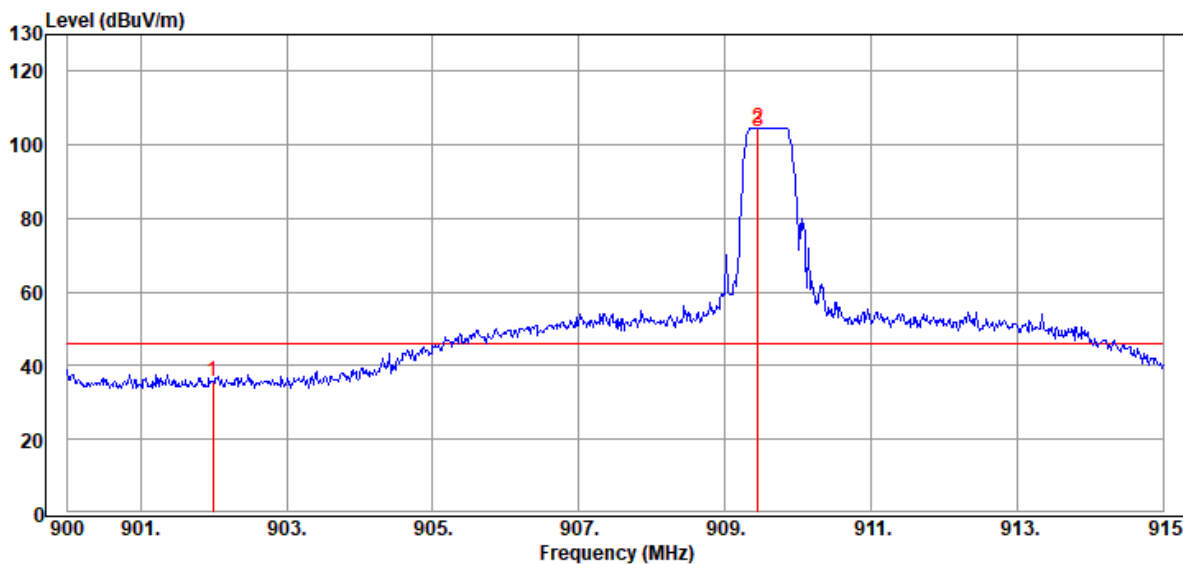

Item Mark	Freq. MHz	Reading dBuV	Factor dB/m	Level dBuV/m	Limit dBuV/m	Margin dB	Remark
1	901.995	56.35	-20.75	35.60	46.00	-10.40	Peak
* 2	909.450	124.87	-20.46	104.41	46.00	58.41	Peak
3	909.450	123.90	-20.46	103.44	46.00	57.44	Average

CLIENT: Nutek Corporation
 EUT: Transceiver
 MODEL: CAIVU-LR
 RATING: DC 5V
 COMMENT: bandedge

OPERATOR : Scott
 TEST SITE : Chamber 3
 TEST DISTANCE : 3 m
 POLARIZATION : VERTICAL
 TEMP/HUM : 25.2°C/42%

Data:272

2021-04-21

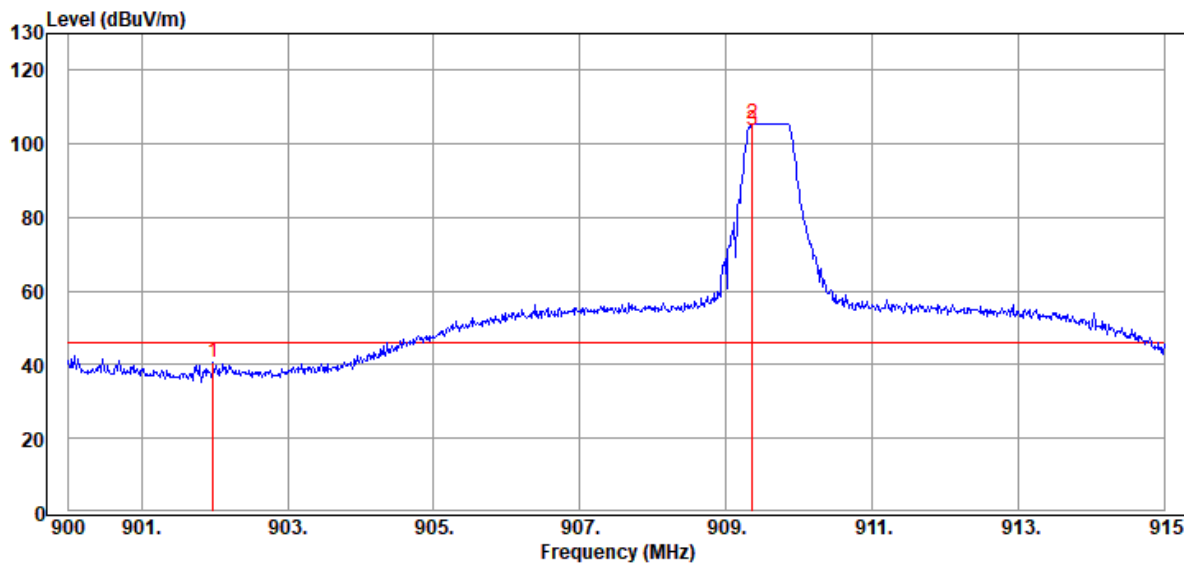

Item Mark	Freq. MHz	Reading dBuV	Factor dB/m	Level dBuV/m	Limit dBuV/m	Margin dB	Remark
1	901.980	61.32	-20.75	40.57	46.00	-5.43	Peak
* 2	909.360	125.94	-20.47	105.47	46.00	59.47	Peak
3	909.360	124.20	-20.47	103.73	46.00	57.73	Average

Band-edge_Conducted

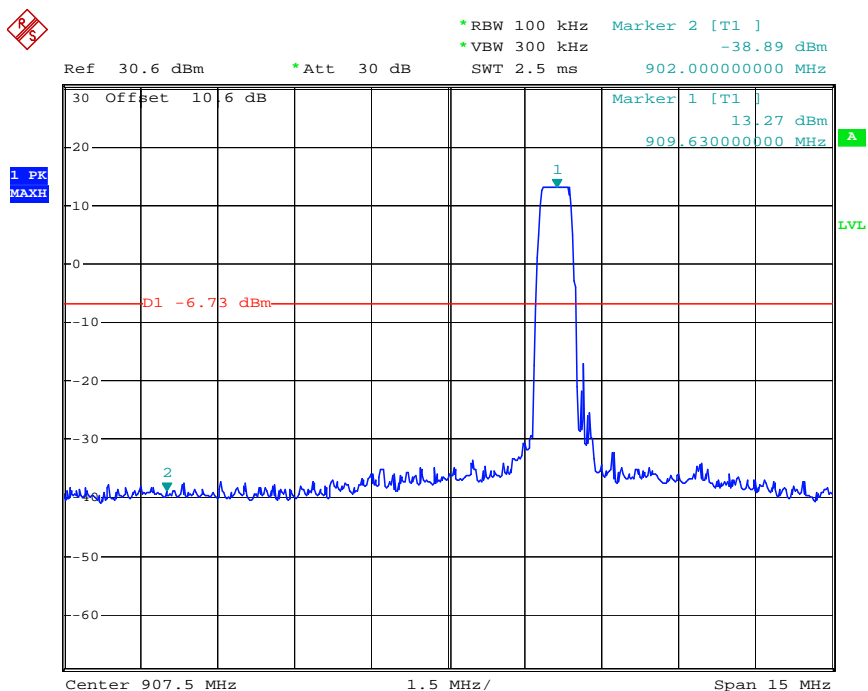

Date: 28.MAY.2021 12:40:09