

ENGINEERING TEST REPORT

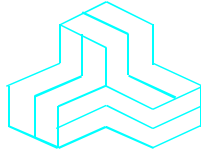

SYNTHESIZED NETLINK RADIO DATA SYSTEM
Model No.: SX150EN11C & SX150EN11G
FCC ID: D4H-SX150EN11C-G

Applicant: **ARIA/GLB WIRELESS DATA**
156 Snowil Drive
Buffalo, NY
USA, 14225

Tested in Accordance With

Federal Communications Commission (FCC)
CFR 47, PARTS 2 and 90 (Subpart I)

UltraTech's File No.: GLB-006FT

This Test report is Issued under the Authority of Tri M. Luu, Professional Engineer, Vice President of Engineering UltraTech Group of Labs	
Date:	
Report Prepared by: Tri M. Luu, P.Eng.	Tested by: Hung Tring, EMI/RFI Technician
Issued Date: Jan. 10, 2000	Test Dates: Jan. 02-09, 2000

The results in this Test Report apply only to the sample(s) tested, and the sample tested is randomly selected.

UltraTech

3000 Bristol Circle, Oakville, Ontario, Canada, L6H 6G4
Telephone (905) 829-1570 Facsimile (905) 829-8050

Website: www.ultratech-labs.com Email: vhk.ultratech@sympatico.ca

TABLE OF CONTENTS

EXHIBIT 1. INTRODUCTION	4
1.1. SCOPE	4
1.2. RELATED SUBMITAL(S)/GRANT(S).....	4
1.3. NORMATIVE REFERENCES	4
EXHIBIT 2. PERFORMANCE ASSESSMENT.....	5
2.1. CLIENT INFORMATION	5
2.2. EQUIPMENT UNDER TEST (EUT) INFORMATION.....	5
2.3. EUT'S TECHNICAL SPECIFICATIONS.....	6
2.4. LIST OF EUT'S PORTS	7
2.5. ANCILLARY EQUIPMENT	7
EXHIBIT 3. EUT OPERATING CONDITIONS AND CONFIGURATIONS DURING TESTS.....	8
3.1. CLIMATE TEST CONDITIONS	8
3.2. OPERATIONAL TEST CONDITIONS & ARRANGEMENT FOR TEST SIGNALS.....	8
EXHIBIT 4. SUMMARY OF TEST RESULTS.....	9
4.1. LOCATION OF TESTS	9
4.2. APPLICABILITY & SUMMARY OF EMC EMISSION TEST RESULTS	9
4.3. MODIFICATIONS INCORPORATED IN THE EUT FOR COMPLIANCE PURPOSES	9
EXHIBIT 5. MEASUREMENTS, EXAMINATIONS & TEST DATA FOR EMC EMISSIONS.....	10
5.1. TEST PROCEDURES.....	10
5.2. MEASUREMENT UNCERTAINTIES	10
5.3. MEASUREMENT EQUIPMENT USED:.....	10
5.4. ESSENTIAL/PRIMARY FUNCTIONS AS DECLARED BY THE MANUFACTURER:.....	10
5.5. RF POWER OUTPUT @ FCC 2.985 & 90.205	11
5.5.1. <i>Limits @ FCC 90.205</i>	11
5.5.2. <i>Method of Measurements</i>	11
5.5.3. <i>Test Equipment List</i>	11
5.5.4. <i>Test Arrangement</i>	11
5.5.5. <i>Test Data</i>	12
5.6. FREQUENCY STABILITY @ FCC 2.995 & 90.213	13
5.6.1. <i>Limits @ FCC 90.213</i>	13
5.6.2. <i>Method of Measurements</i>	13
5.6.3. <i>Test Equipment List</i>	14
5.6.4. <i>Test Arrangement</i>	14
5.6.5. <i>Test Data</i>	14
5.7. MODULATION LIMITING @ FCC 2.987(B) & 90.210	19
5.7.1. <i>Limits @ FCC 2.987(b) and 90.210</i>	19
5.7.2. <i>Method of Measurements</i>	19
5.7.3. <i>Test Equipment List</i>	19
5.7.4. <i>Test Arrangement</i>	19
5.7.5. <i>Test Data</i>	20
5.8. EMISSION MASK @ FCC 2.989, 90.208 & 90.210.....	21
5.8.1. <i>Limits @ FCC 90.209 & 90.210</i>	21
5.8.2. <i>Method of Measurements</i>	21

ULTRATECH GROUP OF LABS

3000 Bristol Circle, Oakville, Ontario, Canada L6H 6G4
Tel. #: 905-829-1570, Fax. #: 905-829-8050, Email: vhk.ultratech@sympatico.ca, Website: <http://www.ultratech-labs.com>

File #: GLB-006FT
Jan. 10, 2000

- Assessed by ITI (UK) Competent Body, NVLAP (USA) Accreditation Body & ACA/AUSTEL (Australia)
- Recognized/Listed by FCC (USA), Industry Canada (Canada)
- All test results contained in this engineering test report are traceable to National Institute of Standards and Technology (NIST)

5.8.3.	Test Equipment List.....	21
5.8.4.	Test Arrangement.....	21
5.8.5.	Test Data	21
5.8.6.	Plots.....	21
5.9.	TRANSMITTER ANTENNA POWER SPURIOUS/HARMONIC CONDUCTED EMISSIONS @ FCC 90.210.....	22
5.9.1.	Limits @ 90.210.....	22
5.9.2.	Method of Measurements	22
5.9.3.	Test Equipment List.....	22
5.9.4.	Test Arrangement.....	22
5.9.5.	Test Data	23
5.9.6.	Plots.....	26
5.10.	TRANSMITTER SPURIOUS/HARMONIC RADIATED EMISSIONS @ FCC 90.210.....	27
5.10.1.	Limits @ FCC 90.210	27
5.10.2.	Method of Measurements	27
5.10.3.	Test Equipment List.....	27
5.10.4.	Test Data	28
5.10.5.	Photographs of Test Setup.....	40
5.11.	TRANSIENT FREQUENCY BEHAVIOR @ 90.214.....	42
5.11.1.	Limits.....	42
5.11.2.	Method of Measurements	42
5.11.3.	Test Equipment List.....	43
5.11.4.	Test Arrangement.....	44
5.11.5.	Test Data	45
5.11.6.	Plots.....	48
EXHIBIT 6.	MEASUREMENT UNCERTAINTY.....	49
6.1.	RADIATED EMISSION MEASUREMENT UNCERTAINTY	49
EXHIBIT 7.	MEASUREMENT METHODS.....	50
7.1.	EFFECTIVE RADIATED POWER (ERP) MEASUREMENTS	50
7.2.	FREQUENCY STABILITY.....	52
7.3.	EMISSION MASK.....	53
7.4.	SPURIOUS EMISSIONS (CONDUCTED).....	53
7.5.	SPURIOUS EMISSIONS (RADIATED).....	54
7.6.	TRANSIENT FREQUENCY BEHAVIOR.....	56
EXHIBIT 8.	PLOTS OF MEASUREMENT DATA.....	57
EXHIBIT 9.	PHOTOGRAPHS OF TEST SETUP.....	58
EXHIBIT 10.	FCC FORM 731, APPLICANT’S LETTERS & STATEMENT	59
10.1.	FCC FORM 731.....	59
10.2.	APPLICANT’S AUTHORIZATION TO APPOINT ULTRATECH ENGINEERING LABS INC. TO ACT AS AN AGENT	59
10.3.	LETTER REQUEST FOR FCC CONFIDENTIALITY FILING	59
10.4.	RESTRICTION FOR USES OF THIS RADIO TRANSMITTER IN IN 406-406.1 MHZ BAND	59
10.5.	RADIO FREQUENCY RADIATION EXPOSURE EVALUATION: MOBILE & UNLICENSED DEVICES@ FCC 2.1091	59
EXHIBIT 11.	FCC ID LABEL & SKETCH OF LABEL LOCATION.....	60
EXHIBIT 12.	“FCC INFORMATION TO USER”	61

ULTRATECH GROUP OF LABS

3000 Bristol Circle, Oakville, Ontario, Canada L6H 6G4
 Tel. #: 905-829-1570, Fax. #: 905-829-8050, Email: vhk.ultratech@sympatico.ca, Website: <http://www.ultratech-labs.com>

File #: GLB-006FT
 Jan. 10, 2000

- Assessed by ITI (UK) Competent Body, NVLAP (USA) Accreditation Body & ACA/AUSTEL (Australia)
- Recognized/Listed by FCC (USA), Industry Canada (Canada)
- All test results contained in this engineering test report are traceable to National Institute of Standards and Technology (NIST)

EXHIBIT 13. PHOTOGRAPHS OF EQUIPMENT UNDER TEST	62
EXHIBIT 14. SYSTEM BLOCK DIAGRAM(S) & SCHEMATIC DIAGRAMS.....	63
EXHIBIT 15. USER'S MANUAL	64

ULTRATECH GROUP OF LABS

3000 Bristol Circle, Oakville, Ontario, Canada L6H 6G4
Tel. #: 905-829-1570, Fax. #: 905-829-8050, Email: vhk.ultratech@sympatico.ca, Website: <http://www.ultratech-labs.com>

File #: GLB-006FT
Jan. 10, 2000

- Assessed by ITI (UK) Competent Body, NVLAP (USA) Accreditation Body & ACA/AUSTEL (Australia)
- Recognized/Listed by FCC (USA), Industry Canada (Canada)
- *All test results contained in this engineering test report are traceable to National Institute of Standards and Technology (NIST)*

EXHIBIT 1. INTRODUCTION

1.1. SCOPE

Reference:	FCC Parts 2 and 90
Title	Telecommunication - Code of Federal Regulations, CFR 47, Parts 2 & 90
Purpose of Test:	To gain FCC Certification Authorization for Radio operating in the frequency bands 150 - 174 MHz (12.5 kHz and 25 kHz Channel Spacings).
Test Procedures	Both conducted and radiated emissions measurements were conducted in accordance with American National Standards Institute ANSI C63.4 - American National Standard for Methods of Measurement of Radio-Noise Emissions from Low-Voltage Electrical and Electronic Equipment in the Range of 9 kHz to 40 GHz.

1.2. RELATED SUBMITAL(S)/GRANT(S)

None

1.3. NORMATIVE REFERENCES

Note: When the international publication has been modified by common modifications, indicated by (mod), the relevant EN/HD applies.

Publication	YEAR	Title
FCC CFR Parts 0-19, 80-End	1998	Code of Federal Regulations – Telecommunication
ANSI C63.4	1992	American National Standard for Methods of Measurement of Radio-Noise Emissions from Low-Voltage Electrical and Electronic Equipment in the Range of 9 kHz to 40 GHz
CISPR 22 & EN 55022	1997 1998	Limits and Methods of Measurements of Radio Disturbance Characteristics of Information Technology Equipment
CISPR 16-1		Specification for Radio Disturbance and Immunity measuring apparatus and methods

ULTRATECH GROUP OF LABS

3000 Bristol Circle, Oakville, Ontario, Canada L6H 6G4
 Tel. #: 905-829-1570, Fax. #: 905-829-8050, Email: yhk.ultratech@sympatico.ca, Website: <http://www.ultratech-labs.com>

File #: GLB-006FT
 Jan. 10, 2000

- Assessed by ITI (UK) Competent Body, NVLAP (USA) Accreditation Body & ACA/AUSTEL (Australia)
- Recognized/Listed by FCC (USA), Industry Canada (Canada)
- All test results contained in this engineering test report are traceable to National Institute of Standards and Technology (NIST)

EXHIBIT 2. PERFORMANCE ASSESSMENT

2.1. CLIENT INFORMATION

APPLICANT:	
Name:	ARIA/GLB WIRELESS DATA
Address:	156 Snowil Drive Buffalo, NY USA, 14225
Contact Person:	Mr. Scott Zmuda Phone #: 716-681-8750 Fax #: 716-683-9786 Email Address: szmuda@aria-glb.com

MANUFACTURER:	
Name:	GLB Electronics
Address:	156 Snowil Drive Buffalo, NY USA, 14225
Contact Person:	Mr. Scott Zmuda Phone #: 716-681-8750 Fax #: 716-683-9786 Email Address: szmuda@aria-glb.com

2.2. EQUIPMENT UNDER TEST (EUT) INFORMATION

The following information (with the exception of the Date of Receipt) has been supplied by the applicant.

Brand Name	ARIA/GLB WIRELESS DATA
Product Name	SYNTHESIZED NETLINK RADIO DATA SYSTEM
Model Name or Number	SX150EN11C & SX150EN11G
Serial Number	908065 (35.5 Watt Radio) & 908064 (7.7 Watts Radio)
Type of Equipment	Radio Communication Equipment
External Power Supply	None
Transmitting/Receiving Antenna Type	Non-integral
Primary User Functions of EUT:	Radio data communication link through air

ULTRATECH GROUP OF LABS

3000 Bristol Circle, Oakville, Ontario, Canada L6H 6G4
 Tel. #: 905-829-1570, Fax. #: 905-829-8050, Email: yhk.ultratech@sympatico.ca, Website: <http://www.ultratech-labs.com>

File #: GLB-006FT
 Jan. 10, 2000

- Assessed by ITI (UK) Competent Body, NVLAP (USA) Accreditation Body & ACA/AUSTEL (Australia)
- Recognized/Listed by FCC (USA), Industry Canada (Canada)
- All test results contained in this engineering test report are traceable to National Institute of Standards and Technology (NIST)

2.3. EUT'S TECHNICAL SPECIFICATIONS

TRANSMITTER	
Equipment Type:	Mobile Base station (fixed use)
Intended Operating Environment:	Commercial, light industry & heavy industry
Power Supply Requirement:	DC 12.5 Volts
RF Output Power Rating:	7.7 Watts (low) and 35.5 Watts (high) No adjustable switch
Operating Frequency Range:	150 - 174 MHz
RF Output Impedance:	50 Ohms
Channel Spacing:	12.5 kHz & 25 kHz
Occupied Bandwidth (99%):	5.9 kHz (12.5 kHz Channel Spacing) 19 kHz (25 kHz Channel Spacing)
Data Rate	9600 b/s max.(12.5 kHz Channel Spacing) 19200 b/s max. (25 kHz Channel Spacing)
Emission Designation*:	9K8F1D.(12.5 kHz Channel Spacing) 18K8F1D (25 kHz Channel Spacing)
Digital Oscillator	12.288 MHz, 4.9152 MHz
Radio Oscillator Frequencies:	21.4 MHz (IF), 455 kHz (IF), 20.945 MHz, 12.8 MHz
Antenna Connector Type:	BNC, N, TNC, SMA or integral

* For an average case of commercial telephony, the Necessary Bandwidth is calculated as follows:

For FM Digital Modulation:

Channel Spacing = 12.5 KHz, D = 2.5 KHz max., K = 1, M = 9.6 kb/s / Level of FM,
 Level of FM = 4
 M = 9.6/4 kb/s
 $B_n = 2M + 2DK = 2(9.6/4) + 2(2.5)(1) = \mathbf{9.8\ KHz}$
 emission designation: 9K8F1D

Channel Spacing = 25 KHz, D = 4.5 KHz max., K = 1, M = 19.2 kb/s / Level of FM,
 Level of FM = 4
 M = 19.2/4 kb/s
 $B_n = 2M + 2DK = 2(19.2/4) + 2(4.5)(1) = \mathbf{18.8\ KHz}$
 emission designation: 18K8F1D

ULTRATECH GROUP OF LABS

3000 Bristol Circle, Oakville, Ontario, Canada L6H 6G4
 Tel. #: 905-829-1570, Fax. #: 905-829-8050, Email: yhk.ultratech@sympatico.ca, Website: <http://www.ultratech-labs.com>

File #: GLB-006FT
 Jan. 10, 2000

- Assessed by ITI (UK) Competent Body, NVLAP (USA) Accreditation Body & ACA/AUSTEL (Australia)
- Recognized/Listed by FCC (USA), Industry Canada (Canada)
- All test results contained in this engineering test report are traceable to National Institute of Standards and Technology (NIST)

2.4. LIST OF EUT'S PORTS

Port Number	EUT's Port Description	Number of Identical Ports	Connector Type	Cable Type (Shielded/Non-shielded)
1	RS-232. Note (2)	1	DB25	Shielded
2	RF Input/Output	1	BNC	Shielded

NOTES:

- (1) **Ports of the EUT which in normal operation** were connected to ancillary equipment through interconnecting cables via a representative interconnecting cable to simulate the input/output characteristics. RF input/output was correctly terminated to the 50 Ohm RF Load.
- (2) **Ports which are not connected to cables during normal intended operation** (for factory/technical services uses only)

2.5. ANCILLARY EQUIPMENT

The EUT was tested while connected to the following representative configuration of ancillary equipment necessary to exercise the ports during tests:

Ancillary Equipment # 1	
Description:	Omnibook Laptop Computer
Brand name:	Hewlett Packard
Model Name or Number:	5500CS
Serial Number:	TW63493246
Cable Length & Type:	6 feet
Connected to EUT's Port:	RS-232 (DB25) Port

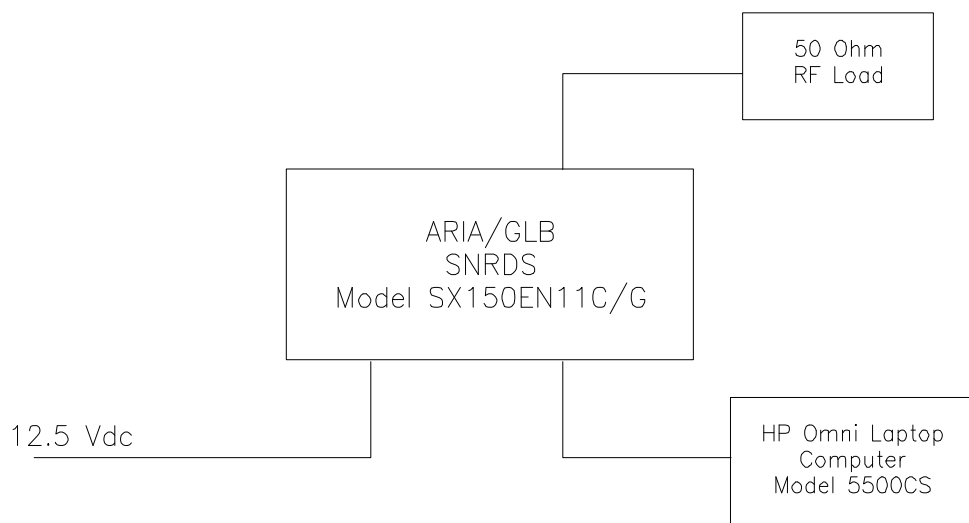

ULTRATECH GROUP OF LABS

3000 Bristol Circle, Oakville, Ontario, Canada L6H 6G4
 Tel. #: 905-829-1570, Fax. #: 905-829-8050, Email: yhk.ultratech@sympatico.ca, Website: <http://www.ultratech-labs.com>

File #: GLB-006FT
 Jan. 10, 2000

- Assessed by ITI (UK) Competent Body, NVLAP (USA) Accreditation Body & ACA/AUSTEL (Australia)
- Recognized/Listed by FCC (USA), Industry Canada (Canada)
- All test results contained in this engineering test report are traceable to National Institute of Standards and Technology (NIST)

EXHIBIT 3. EUT OPERATING CONDITIONS AND CONFIGURATIONS DURING TESTS

3.1. CLIMATE TEST CONDITIONS

The climate conditions of the test environment are as follows:

Temperature:	21°C
Humidity:	51%
Pressure:	102 kPa
Power input source:	DC 12.5 Volts

3.2. OPERATIONAL TEST CONDITIONS & ARRANGEMENT FOR TEST SIGNALS

Operating Modes:	The transmitter was operated in a continuous transmission mode with the carrier modulated as specified in the Test Data.
Special Test Software:	Aria/GLB software was used for setting the operation via channel frequency and channel spacing
Special Hardware Used:	N/A
Transmitter Test Antenna:	The EUT is tested with the transmitter antenna port terminated to a 50 Ohm RF Load.

Transmitter Test Signals:	
Frequencies:	Near lowest, near middle & near highest frequencies each frequency bands that the transmitter covers:
<ul style="list-style-type: none"> ▪ 150-174 MHz band: 	<ul style="list-style-type: none"> ▪ 150 MHz, 157 MHz & 164 MHz
Transmitter Wanted Output Test Signals:	
<ul style="list-style-type: none"> ▪ RF Power Output (measured maximum output power): ▪ Normal Test Modulation 	<ul style="list-style-type: none"> ▪ 7.7 Watts and 35.5 Watts ▪ 4 Level FM Modulation with internal 9600 b/s random data for 12.5 kHz Channel Spacing operation and 4 Level FM Modulation with 19200 b/s random data for 25 kHz Channel Spacing operation.
<ul style="list-style-type: none"> ▪ Modulating signal source: 	<ul style="list-style-type: none"> ▪ Internal/external

ULTRATECH GROUP OF LABS

3000 Bristol Circle, Oakville, Ontario, Canada L6H 6G4
 Tel. #: 905-829-1570, Fax. #: 905-829-8050, Email: yhk.ultratech@sympatico.ca, Website: <http://www.ultratech-labs.com>

File #: GLB-006FT
 Jan. 10, 2000

- Assessed by ITI (UK) Competent Body, NVLAP (USA) Accreditation Body & ACA/AUSTEL (Australia)
- Recognized/Listed by FCC (USA), Industry Canada (Canada)
- All test results contained in this engineering test report are traceable to National Institute of Standards and Technology (NIST)

EXHIBIT 4. SUMMARY OF TEST RESULTS

4.1. LOCATION OF TESTS

All of the measurements described in this report were performed at Ultratech Group of Labs located in the city of Oakville, Province of Ontario, Canada.

- Radiated Emissions were performed at the Ultratech's 3 Meter Open Field Test Site (OFTS) situated in the Town of Oakville, province of Ontario.

The above sites have been calibrated in accordance with ANSI C63.4, and found to be in compliance with the requirements of Sec. 2.948 of the FCC Rules. The descriptions and site measurement data of the Oakville Open Field Test Site has been filed with FCC office (FCC File No.: 31040/SIT 1300B3) and Industry Canada office (Industry Canada File No.: IC2049). Last Date of Site Calibration: Sep. 20, 1999.

4.2. APPLICABILITY & SUMMARY OF EMC EMISSION TEST RESULTS

FCC PARAGRAPH.	TEST REQUIREMENTS	APPLICABILITY (YES/NO)
90.205 & 2.985	RF Power Output	Yes
90.213 & 2.995	Frequency Stability	Yes
90.242(b)(8) & 2.987(a)	Audio Frequency Response	N/A
90.210 & 2.987(b)	Modulation Limiting	Yes
90.209 90.210 & 2.989	Emission Limitation & Emission Mask	Yes
90.210, 2.997 & 2.991	Emission Limits - Spurious Emissions at Antenna Terminal	Yes
90.210, 2.997 & 2.993	Emission Limits - Field Strength of Spurious Emissions	Yes
90.214	Transient Frequency Behavior	Yes

SYNTHESIZED NETLINK RADIO DATA SYSTEM, Model No.: SX150EN11C & SX150EN11G, by **ARIA/GLB WIRELESS DATA** has also been tested and found to comply with **FCC Part 15, Subpart B - Radio Receivers and Class A Digital Devices**. The engineering test report has been documented and kept in file and it is available anytime upon FCC request.

4.3. MODIFICATIONS INCORPORATED IN THE EUT FOR COMPLIANCE PURPOSES

None

ULTRATECH GROUP OF LABS

3000 Bristol Circle, Oakville, Ontario, Canada L6H 6G4
 Tel. #: 905-829-1570, Fax. #: 905-829-8050, Email: yhk.ultratech@sympatico.ca, Website: <http://www.ultratech-labs.com>

File #: GLB-006FT
 Jan. 10, 2000

- Assessed by ITI (UK) Competent Body, NVLAP (USA) Accreditation Body & ACA/AUSTEL (Australia)
- Recognized/Listed by FCC (USA), Industry Canada (Canada)
- All test results contained in this engineering test report are traceable to National Institute of Standards and Technology (NIST)

EXHIBIT 5. MEASUREMENTS, EXAMINATIONS & TEST DATA FOR EMC EMISSIONS

5.1. TEST PROCEDURES

This section contains test results only. Details of test methods and procedures can be found in Exhibit 7 of this report

5.2. MEASUREMENT UNCERTAINTIES

The measurement uncertainties stated were calculated in accordance with requirements of UKAS Document NIS 81 with a confidence level of 95%. Please refer to Exhibit 6 for Measurement Uncertainties.

5.3. MEASUREMENT EQUIPMENT USED:

The measurement equipment used complied with the requirements of the Standards referenced in the Methods & Procedures ANSI C63.4:1992 and CISPR 16-1.

5.4. ESSENTIAL/PRIMARY FUNCTIONS AS DECLARED BY THE MANUFACTURER:

The essential function of the EUT is to correctly communicate data to and from radios over RF link.

ULTRATECH GROUP OF LABS

3000 Bristol Circle, Oakville, Ontario, Canada L6H 6G4
Tel. #: 905-829-1570, Fax. #: 905-829-8050, Email: yhk.ultratech@sympatico.ca, Website: <http://www.ultratech-labs.com>

File #: GLB-006FT
Jan. 10, 2000

- Assessed by ITI (UK) Competent Body, NVLAP (USA) Accreditation Body & ACA/AUSTEL (Australia)
- Recognized/Listed by FCC (USA), Industry Canada (Canada)
- *All test results contained in this engineering test report are traceable to National Institute of Standards and Technology (NIST)*

5.5. RF POWER OUTPUT @ FCC 2.985 & 90.205

5.5.1. Limits @ FCC 90.205

Please refer to FCC CFR 47, Part 90, Subpart I, Para. 90.205(d) for specification details.

5.5.2. Method of Measurements

FCC @ 2.985 – The rf output power of the transmitter was measured at the RF output terminals when the transmitter is adjusted by the manufacturer in accordance with the tune-up procedure to give the values of the current and voltage on the circuit elements specified in 2.983(d)(5). The electrical characteristics of the radio frequency load attached to the output terminals was 50 Ohms.

The detailed test method is as follows:

- *The transmitter terminal was coupled to the Spectrum Analyzer through a 30 dB Attenuator*
- *Power of the transmitter channel near the lowest, middle and highest of each frequency block/band were measured using the power meter, and the reading was corrected by added the calibrated attenuator's attenuation value and cable loss.*
- *The RF Output was turned on with standard modulation applied.*

5.5.3. Test Equipment List

Test Instruments	Manufacturer	Model No.	Serial No.	Frequency Range
Spectrum Analyzer/ EMI Receiver	Hewlett Packard	HP 8593EM	3412A00103	9 kHz – 26.5 GHz
Attenuator(s)	Bird	DC – 22 GHz

5.5.4. Test Arrangement

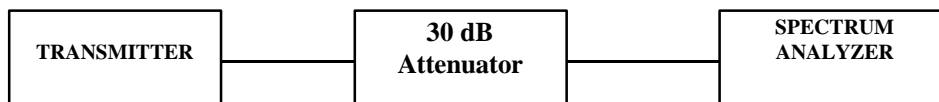

5.5.5. Test Data

5.5.5.1. Test Configuration #1: RF Output Power Rating (7.7 Watts)

TRANSMITTER CHANNEL OUTPUT	FUNDAMENTAL FREQUENCY (MHz)	MEASURED AVERAGE POWER (P) (dBm)	AVERAGE POWER RATING (dBm)	Maximum Allowable EIRP (dBm)	Calculated Maximum Allowable Antenna Gain (dBi)
Lowest	150	37.7	38.9	--	--
Middle	157	38.4	38.9	--	--
Highest	164	38.9	38.9	--	--

Note: Refer to FCC 90.205(d) for detailed EIRP power requirements at different service area radius

Note (1): This radio is used as the base or mobile, and its transmitter antenna is required to be located at least 20 cm away from the users; therefore, SAR tests are exempted.

5.5.5.2. Test Configuration #2: RF Output Power Rating (35.5 Watts)

TRANSMITTER CHANNEL OUTPUT	FUNDAMENTAL FREQUENCY (MHz)	MEASURED AVERAGE POWER (P) (dBm)	AVERAGE POWER RATING (dBm)	Maximum Allowable EIRP (dBm)	Calculated Maximum Allowable Antenna Gain (dBi)
Lowest	150	45.5	45.5	--	--
Middle	157	45.4	45.5	--	--
Highest	164	45.0	45.5	--	--

Note: Refer to FCC 90.205(d) for detailed EIRP power requirements at different service area radius

Note (1): This radio is used as the base or mobile, and its transmitter antenna is required to be located at least 20 cm away from the users; therefore, SAR tests are exempted.

5.6. FREQUENCY STABILITY @ FCC 2.995 & 90.213

5.6.1. Limits @ FCC 90.213

Please refer to FCC CFR 47, Part 90, Subpart I, Para. 90.213 for specification details.

FREQUENCY RANGE (MHz)	FIXED & BASE STATIONS (ppm)			MOBILE STATIONS (ppm)					
				> 2 W			≤ 2 W		
	6.25 kHz	12.5 kHz	25 kHz	6.25 kHz	12.5 kHz	25 kHz	6.25 kHz	12.5 kHz	25 kHz
150 - 174 MHz	1.0	2.5	5	2.0	5.0	5.0	2.0	5.0	50

5.6.2. Method of Measurements

Refer to FCC @ 2.995

- (a) The frequency stability shall be measured with variation of ambient temperature as follows: From -30 to +50 centigrade except that specified in subparagraph (2) & (3) of this paragraph.
- (b) Frequency measurements shall be made at extremes of the specified temperature range and at intervals of not more than 10 centigrade through the range. A period of time sufficient to stabilize all of the components of the oscillator circuit at each temperature level shall be allowed prior to frequency measurement. The short term transient effects on the frequency of the transmitter due to keying (except for broadcast transmitters) and any heating element cycling normally occurring at each ambient temperature level also shall be shown. Only the portion or portions of the transmitter containing the frequency determining and stability circuitry need be subjected to the temperature variation test.
- (d) The frequency stability supply shall be measured with variation of primary supply voltage as follows:
 - (1) Vary primary supply voltage from 85 to 115 percent of the nominal value for other than hand carried battery equipment.
 - (2) For hand carried, battery powered equipment, reduce primary supply voltage to the battery operating end point which shall be specified by the manufacturer.
 - (3) The supply voltage shall be measured at the input to the cable normally provide with the equipment, or at the power supply terminals if cables are not normally provided. Effects on frequency of transmitter keying (except for broadcast transmitters) and any heating element cycling at the nominal supply voltage and at each extreme also shall be shown.
- (e) When deemed necessary, the Commission may require tests of frequency stability under conditions in addition to those specifically set out in paragraphs (a), (b), (c) and (d) of this section. (For example, measurements showing the effect of proximity to large metal objects, or of various types of antennas, may be required for portable equipment).

ULTRATECH GROUP OF LABS

3000 Bristol Circle, Oakville, Ontario, Canada L6H 6G4
 Tel. #: 905-829-1570, Fax. #: 905-829-8050, Email: vhk.ultratech@sympatico.ca, Website: <http://www.ultratech-labs.com>

File #: GLB-006FT
 Jan. 10, 2000

- Assessed by ITI (UK) Competent Body, NVLAP (USA) Accreditation Body & ACA/AUSTEL (Australia)
- Recognized/Listed by FCC (USA), Industry Canada (Canada)
- All test results contained in this engineering test report are traceable to National Institute of Standards and Technology (NIST)

5.6.3. Test Equipment List

Test Instruments	Manufacturer	Model No.	Serial No.	Frequency Range
Spectrum Analyzer/ EMI Receiver	Hewlett Packard	HP 8593EM	3412A00103	9 kHz – 26.5 GHz
Attenuator(s)	Bird	DC – 22 GHz
Temperature & Humidity Chamber	Tenney	T5	9723B	-40° to +60° C range

5.6.4. Test Arrangement

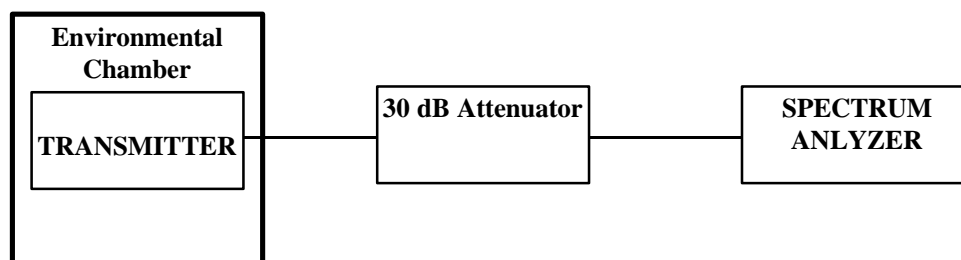

5.6.5. Test Data

Product Name	SYNTHESIZED NETLINK RADIO DATA SYSTEM
Model No.	SX150EN11C & SX150EN11G
Center Frequency	150 MHz
Full Power Level	35.5 Watts
Frequency Tolerance Limit	2.5 ppm or 375 Hz at 150 MHz
Max. Frequency Tolerance Measured	230 Hz or 1.5 ppm
Input Voltage Rating	+12.5 Vdc

ULTRATECH GROUP OF LABS

3000 Bristol Circle, Oakville, Ontario, Canada L6H 6G4
 Tel. #: 905-829-1570, Fax. #: 905-829-8050, Email: yhk.ultratech@sympatico.ca, Website: <http://www.ultratech-labs.com>

File #: GLB-006FT
 Jan. 10, 2000

- Assessed by ITI (UK) Competent Body, NVLAP (USA) Accreditation Body & ACA/AUSTEL (Australia)
- Recognized/Listed by FCC (USA), Industry Canada (Canada)
- All test results contained in this engineering test report are traceable to National Institute of Standards and Technology (NIST)

		CENTER FREQUENCY & RF POWER OUTPUT VARIATION					
AMBIENT TEMP. (°C)	KEYED-ON TIME (Minutes)	Supply Voltage (Nominal) 12.5 Volts dc		Supply Voltage (85% of Nominal) 10.6 Volts dc		Supply Voltage (115% of Nominal) 14.4 Volts dc	
		Hz	dB	Hz	dB	Hz	dB
-30	0	+140	N/A	N/A	N/A	N/A	N/A
	1	+110	N/A	N/A	N/A	N/A	N/A
	2	+200	N/A	N/A	N/A	N/A	N/A
	3	+150	N/A	N/A	N/A	N/A	N/A
	4	+160	N/A	N/A	N/A	N/A	N/A
	5	+200	N/A	N/A	N/A	N/A	N/A
	6	+170	N/A	N/A	N/A	N/A	N/A
	7	+170	N/A	N/A	N/A	N/A	N/A
	8	+230	N/A	N/A	N/A	N/A	N/A
	9	+170	N/A	N/A	N/A	N/A	N/A
	10	+200	N/A	N/A	N/A	N/A	N/A
-20	0	-90	N/A	N/A	N/A	N/A	N/A
	1	-30	N/A	N/A	N/A	N/A	N/A
	2	-60	N/A	N/A	N/A	N/A	N/A
	3	-30	N/A	N/A	N/A	N/A	N/A
	4	0	N/A	N/A	N/A	N/A	N/A
	5	-90	N/A	N/A	N/A	N/A	N/A
	6	-30	N/A	N/A	N/A	N/A	N/A
	7	-90	N/A	N/A	N/A	N/A	N/A
	8	-30	N/A	N/A	N/A	N/A	N/A
	9	-90	N/A	N/A	N/A	N/A	N/A
	10	-80	N/A	N/A	N/A	N/A	N/A
-10	0	0	N/A	N/A	N/A	N/A	N/A
	1	0	N/A	N/A	N/A	N/A	N/A
	2	-30	N/A	N/A	N/A	N/A	N/A
	3	+30	N/A	N/A	N/A	N/A	N/A
	4	+60	N/A	N/A	N/A	N/A	N/A
	5	0	N/A	N/A	N/A	N/A	N/A
	6	+10	N/A	N/A	N/A	N/A	N/A
	7	-30	N/A	N/A	N/A	N/A	N/A
	8	-30	N/A	N/A	N/A	N/A	N/A
	9	+10	N/A	N/A	N/A	N/A	N/A
	10	-20	N/A	N/A	N/A	N/A	N/A
0	0	+60	N/A	N/A	N/A	N/A	N/A
	1	+60	N/A	N/A	N/A	N/A	N/A
	2	+60	N/A	N/A	N/A	N/A	N/A
	3	+90	N/A	N/A	N/A	N/A	N/A
	4	+30	N/A	N/A	N/A	N/A	N/A
	5	+90	N/A	N/A	N/A	N/A	N/A
	6	+90	N/A	N/A	N/A	N/A	N/A
	7	+60	N/A	N/A	N/A	N/A	N/A
	8	+30	N/A	N/A	N/A	N/A	N/A
	9	+90	N/A	N/A	N/A	N/A	N/A
	10	+90	N/A	N/A	N/A	N/A	N/A

ULTRATECH GROUP OF LABS

3000 Bristol Circle, Oakville, Ontario, Canada L6H 6G4
 Tel. #: 905-829-1570, Fax. #: 905-829-8050, Email: yhk.ultratech@sympatico.ca, Website: <http://www.ultratech-labs.com>

File #: GLB-006FT
 Jan. 10, 2000

- Assessed by ITI (UK) Competent Body, NVLAP (USA) Accreditation Body & ACA/AUSTEL (Australia)
- Recognized/Listed by FCC (USA), Industry Canada (Canada)
- All test results contained in this engineering test report are traceable to National Institute of Standards and Technology (NIST)

ULTRATECH GROUP OF LABS

3000 Bristol Circle, Oakville, Ontario, Canada L6H 6G4
Tel. #: 905-829-1570, Fax. #: 905-829-8050, Email: yhk.ultratech@sympatico.ca, Website: <http://www.ultratech-labs.com>

File #: GLB-006FT
Jan. 10, 2000

- Assessed by ITI (UK) Competent Body, NVLAP (USA) Accreditation Body & ACA/AUSTEL (Australia)
- Recognized/Listed by FCC (USA), Industry Canada (Canada)
- *All test results contained in this engineering test report are traceable to National Institute of Standards and Technology (NIST)*

		CENTER FREQUENCY & RF POWER OUTPUT VARIATION					
AMBIENT TEMP. (°C)	KEYED-ON TIME (Minutes)	Supply Voltage (Nominal) 12.5 Volts dc		Supply Voltage (85% of Nominal) 10.6 Volts dc		Supply Voltage (115% of Nominal) 14.4 Volts dc	
		Hz	dB	Hz	dB	Hz	dB
+10	0	+110	N/A	N/A	N/A	N/A	N/A
	1	+90	N/A	N/A	N/A	N/A	N/A
	2	+60	N/A	N/A	N/A	N/A	N/A
	3	+90	N/A	N/A	N/A	N/A	N/A
	4	+60	N/A	N/A	N/A	N/A	N/A
	5	+90	N/A	N/A	N/A	N/A	N/A
	6	+90	N/A	N/A	N/A	N/A	N/A
	7	+90	N/A	N/A	N/A	N/A	N/A
	8	+90	N/A	N/A	N/A	N/A	N/A
	9	+80	N/A	N/A	N/A	N/A	N/A
	10	+90	N/A	N/A	N/A	N/A	N/A
+20	0	+60	N/A	+60	N/A	0	N/A
	1	+30	N/A	+30	N/A	+30	N/A
	2	+30	N/A	+60	N/A	+30	N/A
	3	0	N/A	+90	N/A	+30	N/A
	4	+30	N/A	+30	N/A	0	N/A
	5	+30	N/A	+30	N/A	+60	N/A
	6	+30	N/A	+30	N/A	+60	N/A
	7	+60	N/A	0	N/A	+60	N/A
	8	+30	N/A	+30	N/A	+30	N/A
	9	+30	N/A	+30	N/A	+30	N/A
	10	+30	N/A	+30	N/A	+30	N/A
+30	0	+30	N/A	N/A	N/A	N/A	N/A
	1	0	N/A	N/A	N/A	N/A	N/A
	2	+30	N/A	N/A	N/A	N/A	N/A
	3	+30	N/A	N/A	N/A	N/A	N/A
	4	+90	N/A	N/A	N/A	N/A	N/A
	5	+60	N/A	N/A	N/A	N/A	N/A
	6	+110	N/A	N/A	N/A	N/A	N/A
	7	+30	N/A	N/A	N/A	N/A	N/A
	8	+60	N/A	N/A	N/A	N/A	N/A
	9	+60	N/A	N/A	N/A	N/A	N/A
	10	+60	N/A	N/A	N/A	N/A	N/A
+40	0	+30	N/A	N/A	N/A	N/A	N/A
	1	+90	N/A	N/A	N/A	N/A	N/A
	2	+60	N/A	N/A	N/A	N/A	N/A
	3	+110	N/A	N/A	N/A	N/A	N/A
	4	+90	N/A	N/A	N/A	N/A	N/A
	5	+90	N/A	N/A	N/A	N/A	N/A
	6	+110	N/A	N/A	N/A	N/A	N/A
	7	+60	N/A	N/A	N/A	N/A	N/A
	8	+90	N/A	N/A	N/A	N/A	N/A
	9	+110	N/A	N/A	N/A	N/A	N/A

ULTRATECH GROUP OF LABS

3000 Bristol Circle, Oakville, Ontario, Canada L6H 6G4
 Tel. #: 905-829-1570, Fax. #: 905-829-8050, Email: vhk.ultratech@sympatico.ca, Website: <http://www.ultratech-labs.com>

File #: GLB-006FT
 Jan. 10, 2000

- Assessed by ITI (UK) Competent Body, NVLAP (USA) Accreditation Body & ACA/AUSTEL (Australia)
- Recognized/Listed by FCC (USA), Industry Canada (Canada)
- All test results contained in this engineering test report are traceable to National Institute of Standards and Technology (NIST)

	10	+60	N/A	N/A	N/A	N/A	N/A
--	----	-----	-----	-----	-----	-----	-----

		CENTER FREQUENCY & RF POWER OUTPUT VARIATION					
AMBIENT TEMP. (°C)	KEYED-ON TIME (Minutes)	Supply Voltage (Nominal) 12.5 Volts dc		Supply Voltage (85% of Nominal) 10.6 Volts dc		Supply Voltage (115% of Nominal) 14.4 Volts dc	
		Hz	dB	Hz	dB	Hz	dB
		+50	0	+110	N/A	N/A	N/A
	1	+90	N/A	N/A	N/A	N/A	N/A
	2	+110	N/A	N/A	N/A	N/A	N/A
	3	+60	N/A	N/A	N/A	N/A	N/A
	4	+90	N/A	N/A	N/A	N/A	N/A
	5	+140	N/A	N/A	N/A	N/A	N/A
	6	+140	N/A	N/A	N/A	N/A	N/A
	7	+30	N/A	N/A	N/A	N/A	N/A
	8	+90	N/A	N/A	N/A	N/A	N/A
	9	+110	N/A	N/A	N/A	N/A	N/A
	10	+90	N/A	N/A	N/A	N/A	N/A
+60	0	+200	N/A	N/A	N/A	N/A	N/A
	1	+230	N/A	N/A	N/A	N/A	N/A
	2	+140	N/A	N/A	N/A	N/A	N/A
	3	+200	N/A	N/A	N/A	N/A	N/A
	4	+200	N/A	N/A	N/A	N/A	N/A
	5	+200	N/A	N/A	N/A	N/A	N/A
	6	+170	N/A	N/A	N/A	N/A	N/A
	7	+140	N/A	N/A	N/A	N/A	N/A
	8	+200	N/A	N/A	N/A	N/A	N/A
	9	+170	N/A	N/A	N/A	N/A	N/A
	10	+180	N/A	N/A	N/A	N/A	N/A

ULTRATECH GROUP OF LABS

3000 Bristol Circle, Oakville, Ontario, Canada L6H 6G4
 Tel. #: 905-829-1570, Fax. #: 905-829-8050, Email: yhk.ultratech@sympatico.ca, Website: <http://www.ultratech-labs.com>

File #: GLB-006FT
 Jan. 10, 2000

- Assessed by ITI (UK) Competent Body, NVLAP (USA) Accreditation Body & ACA/AUSTEL (Australia)
- Recognized/Listed by FCC (USA), Industry Canada (Canada)
- All test results contained in this engineering test report are traceable to National Institute of Standards and Technology (NIST)

5.7. MODULATION LIMITING @ FCC 2.987(B) & 90.210

5.7.1. Limits @ FCC 2.987(b) and 90.210

The EUT shall be installed with a modulation limiter which limits the deviation of the FM carrier less than manufacturer's setting provided that the rf output spectrum must meet the required MASK

Recommendation:

- 2.5 kHz for 12.5 kHz and 25 kHz Channel Spacings ,
- 5 kHz for 25 kHz Channel Spacing System).

5.7.2. Method of Measurements

For Audio Transmitter:- The carrier frequency deviation was measured with the tone input signal level varied from 0 Vp to audio input rating level plus 16 dB at frequencies 0.1, 0.5, 1.0, 3.0 and 5.0 kHz. The maximum deviation was recorded at each test condition.

For Data Transmitter with Maximum Frequency Deviation set by Factory:- The EUT was set at maximum frequency deviation, and its peak frequency deviation was then measured using EUT's internal random data source.

5.7.3. Test Equipment List

Test Instruments	Manufacturer	Model No.	Serial No.	Frequency Range
Communication Analyzer	Rohde & Schawrz	SMF02	879988/057	400 kHz - 1000 MHz including AF & RF Signal Generators, SINAD, DISTORTION, DEVIATION meters and etc

5.7.4. Test Arrangement

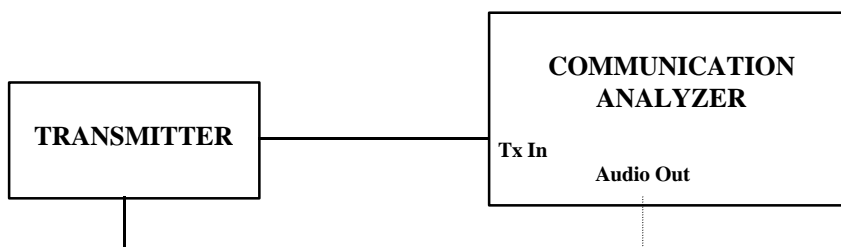

5.7.5. Test Data

Data Modulation Limiting: *FM modulation with random data and Modulation Limiter set at a Maximum Frequency Deviation (Factory Setting).*

DATA BAUD RATE	PEAK DEVIATION (KHz)	MAXIMUM LIMIT (KHz)
9600 for 12.5 kHz Channel Spacing	2.5	2.5
19200 for 25 kHz Channel Spacing	4.5	5.0

ULTRATECH GROUP OF LABS

3000 Bristol Circle, Oakville, Ontario, Canada L6H 6G4
Tel. #: 905-829-1570, Fax. #: 905-829-8050, Email: yhk.ultratech@sympatico.ca, Website: <http://www.ultratech-labs.com>

File #: GLB-006FT
Jan. 10, 2000

- Assessed by ITI (UK) Competent Body, NVLAP (USA) Accreditation Body & ACA/AUSTEL (Australia)
- Recognized/Listed by FCC (USA), Industry Canada (Canada)
- All test results contained in this engineering test report are traceable to National Institute of Standards and Technology (NIST)

5.8. EMISSION MASK @ FCC 2.989, 90.208 & 90.210

5.8.1. Limits @ FCC 90.209 & 90.210

Emissions shall be attenuated below the mean output power of the transmitter as follows:

FREQUENCY RANGE (MHz)	Maximum Authorized BW (KHz)	CHANNEL SPACING (KHz)	Recommended FREQ. DEVIATION (KHz)	FCC APPLICABLE MASK
150 - 174	20.0	25.0	5.0	• 90.210(c): Mask C – Data
150 - 174	11.25	12.5	2.5	• 90.210(d): Mask D – Voice & Data

5.8.2. Method of Measurements

Refer to Exhibit 7, Sec. 7.3 of this report for measurement details

5.8.3. Test Equipment List

Test Instruments	Manufacturer	Model No.	Serial No.	Frequency Range
Spectrum Analyzer/ EMI Receiver	Hewlett Packard	HP 8593EM	3412A00103	9 kHz – 26.5 GHz
Attenuator(s)	Bird	DC – 22 GHz
Audio Oscillator	Hewlett Packard	HP 204C	0989A08798	DC to 1.2 MHz

5.8.4. Test Arrangement

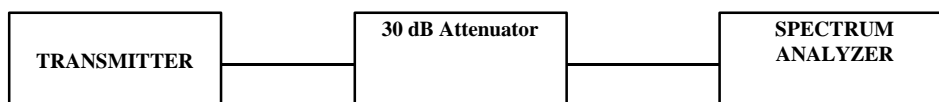

5.8.5. Test Data

Conform. Please refer to the plots below for detailed information.

5.8.6. Plots

Please refer to Plot # 1 through # 16 in Exhibit 8 for Details of measurements of 99% OBW and Emission Mask

5.9. TRANSMITTER ANTENNA POWER SPURIOUS/HARMONIC CONDUCTED EMISSIONS @ FCC 90.210

5.9.1. Limits @ 90.210

Emissions shall be attenuated below the mean output power of the transmitter as follows:

FCC RULES	FREQUENCY RANGE	ATTENUATION LIMIT (dBc)
90.210(b)&(c) – Voice & data	10 MHz to Lowest frequency of the radio to 10 th harmonic of the highest frequency of the radio	43+10*log(P) or -13 dBm
90.210(d) – Voice & data	10 MHz to Lowest frequency of the radio to 10 th harmonic of the highest frequency of the radio	50+10*log(P) or -20 dBm or 70 dBc whichever is less

5.9.2. Method of Measurements

Refer to Exhibit 7, Sec. 7.4 of this report for measurement details

5.9.3. Test Equipment List

Test Instruments	Manufacturer	Model No.	Serial No.	Frequency Range
Spectrum Analyzer/ EMI Receiver	Hewlett Packard	HP 8593EM	3412A00103	9 kHz – 26.5 GHz
Attenuator(s)	Bird	DC – 22 GHz
Audio Oscillator	Hewlett Packard	HP 204C	0989A08798	DC to 1.2 MHz
Hihpass Filter, Microphase	MiniCircuit	SHP-250	Cut-off Frequency at 225 MHz

5.9.4. Test Arrangement

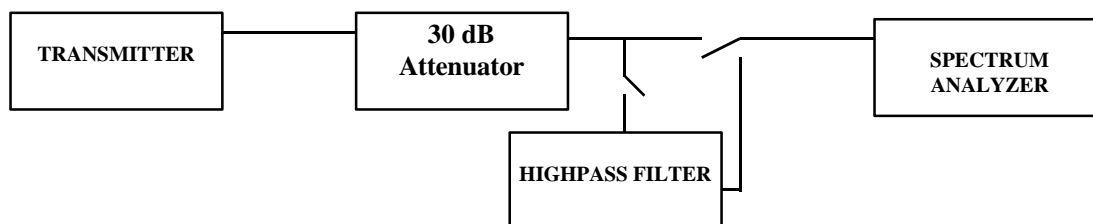

ULTRATECH GROUP OF LABS

3000 Bristol Circle, Oakville, Ontario, Canada L6H 6G4
 Tel. #: 905-829-1570, Fax. #: 905-829-8050, Email: yhk.ultratech@sympatico.ca, Website: <http://www.ultratech-labs.com>

File #: GLB-006FT
 Jan. 10, 2000

- Assessed by ITI (UK) Competent Body, NVLAP (USA) Accreditation Body & ACA/AUSTEL (Australia)
- Recognized/Listed by FCC (USA), Industry Canada (Canada)
- All test results contained in this engineering test report are traceable to National Institute of Standards and Technology (NIST)

5.9.5. Test Data

5.9.5.1. Near Lowest Frequency (150 MHz)

Fundamental Frequency: 150 MHz				
RF Output Power: 6.0 Watts				
Channel Spacing Setting: 12.5 kHz				
Modulation: 4 Level of FM modulation with internal 9600 b/s random data				
FREQUENCY (MHz)	RF LEVEL (dBm)	LIMIT (dBm)	MARGIN (dB)	PASS/ FAIL
450.00	-33.8	-20.0	-13.8	PASS
The emissions were scanned from 10 MHz to 2 GHz and all emissions less 20 dB below the limits were recorded. See Plot #17 in Exhibit 8 of this test report				

Fundamental Frequency: 150 MHz				
RF Output Power: 6.0 Watts				
Channel Spacing Setting: 25 kHz				
Modulation: 4 Level of FM modulation with internal 19200 b/s random data				
FREQUENCY (MHz)	RF LEVEL (dBm)	LIMIT (dBm)	MARGIN (dB)	PASS/ FAIL
450.00	-33.7	-13.0	-20.7	PASS
The emissions were scanned from 10 MHz to 2 GHz and all emissions less 20 dB below the limits were recorded. See Plot #18 in Exhibit 8 of this test report				

Fundamental Frequency: 150 MHz				
RF Output Power: 31.6 Watts				
Channel Spacing Setting: 12.5 kHz				
Modulation: 4 Level of FM modulation with internal 9600 b/s Random data				
FREQUENCY (MHz)	RF LEVEL (dBm)	LIMIT (dBm)	MARGIN (dB)	PASS/ FAIL
208.00	-23.9	-20.0	-3.9	PASS
300.00	-21.8	-20.0	-1.8	PASS
The emissions were scanned from 10 MHz to 2 GHz and all emissions less 10 dB below the limits were recorded. See Plot #19 in Exhibit 8 of this test report				

ULTRATECH GROUP OF LABS

3000 Bristol Circle, Oakville, Ontario, Canada L6H 6G4
 Tel. #: 905-829-1570, Fax. #: 905-829-8050, Email: vhk.ultratech@sympatico.ca, Website: <http://www.ultratech-labs.com>

File #: GLB-006FT
 Jan. 10, 2000

- Assessed by ITI (UK) Competent Body, NVLAP (USA) Accreditation Body & ACA/AUSTEL (Australia)
- Recognized/Listed by FCC (USA), Industry Canada (Canada)
- All test results contained in this engineering test report are traceable to National Institute of Standards and Technology (NIST)

Fundamental Frequency: 150 MHz				
RF Output Power: 35.5 Watts				
Channel Spacing Setting: 25 kHz				
Modulation: 4 Level of FM modulation with internal 19200 b/s Random data				
FREQUENCY (MHz)	RF LEVEL (dBm)	LIMIT (dBm)	MARGIN (dB)	PASS/ FAIL
300	-22.3	-13.0	-9.3	PASS
The emissions were scanned from 10 MHz to 2 GHz and all emissions less 10 dB below the limits were recorded. See Plot #20 in Exhibit 8 of this test report				

5.9.5.2. Near Middle Frequency (157.0000 MHz)

Fundamental Frequency: 157 MHz				
RF Output Power: 7.0 Watts				
Channel Spacing Setting: 12.5 kHz				
Modulation: 4 Level of FM modulation with internal 9600 b/s Random data				
FREQUENCY (MHz)	RF LEVEL (dBm)	LIMIT (dBm)	MARGIN (dB)	PASS/ FAIL
314.00	-24.8	-20.0	-4.8	PASS
471.00	-32.7	-20.0	-12.7	PASS
The emissions were scanned from 10 MHz to 2 GHz and all emissions less 20 dB below the limits were recorded. See Plot #21 in Exhibit 8 of this test report				

Fundamental Frequency: 157 MHz				
RF Output Power: 7.0 Watts				
Channel Spacing Setting: 25 kHz				
Modulation: 4 Level of FM modulation with internal 19200 b/s Random data				
FREQUENCY (MHz)	RF LEVEL (dBm)	LIMIT (dBm)	MARGIN (dB)	PASS/ FAIL
314.00	-25.2	-13.0	-12.2	PASS
471.00	-34.3	-13.0	-21.3	PASS
The emissions were scanned from 10 MHz to 2 GHz and all emissions less 20 dB below the limits were recorded. See Plot #22 in Exhibit 8 of this test report				

ULTRATECH GROUP OF LABS

3000 Bristol Circle, Oakville, Ontario, Canada L6H 6G4
 Tel. #: 905-829-1570, Fax. #: 905-829-8050, Email: vhk.ultratech@sympatico.ca, Website: <http://www.ultratech-labs.com>

File #: GLB-006FT
 Jan. 10, 2000

- Assessed by ITI (UK) Competent Body, NVLAP (USA) Accreditation Body & ACA/AUSTEL (Australia)
- Recognized/Listed by FCC (USA), Industry Canada (Canada)
- All test results contained in this engineering test report are traceable to National Institute of Standards and Technology (NIST)

Fundamental Frequency: 157 MHz				
RF Output Power: 30.0 Watts				
Channel Spacing Setting: 12.5 kHz				
Modulation: 4 Level of FM modulation with internal 9600 b/s Random data				
FREQUENCY (MHz)	RF LEVEL (dBm)	LIMIT (dBm)	MARGIN (dB)	PASS/ FAIL
No significant rf emissions were scanned from 10 MHz to 2 GHz . All emissions were more than 10 dB below the limits. See Plot #23 in Exhibit 8 of this test report				

Fundamental Frequency: 157 MHz				
RF Output Power: 34.5 Watts				
Channel Spacing Setting: 25 kHz				
Modulation: 4 Level of FM modulation with internal 19200 b/s Random data				
FREQUENCY (MHz)	RF LEVEL (dBm)	LIMIT (dBm)	MARGIN (dB)	PASS/ FAIL
No significant rf emissions were scanned from 10 MHz to 2 GHz . All emissions were more than 10 dB below the limits. See Plot #24 in Exhibit 8 of this test report				

5.9.5.3. Near Highest Frequency (164.0000 MHz)

Fundamental Frequency: 164 MHz				
RF Output Power: 7.7 Watts				
Channel Spacing Setting: 12.5 kHz				
Modulation: 4 Level of FM modulation with internal 9600 b/s Random data				
FREQUENCY (MHz)	RF LEVEL (dBm)	LIMIT (dBm)	MARGIN (dB)	PASS/ FAIL
328.00	-21.2	-20.0	-1.2	PASS
492.00	-33.0	-20.0	-13.0	PASS
The emissions were scanned from 10 MHz to 2 GHz and all emissions less 20 dB below the limits were recorded. See Plot #25 in Exhibit 8 of this test report				

ULTRATECH GROUP OF LABS

3000 Bristol Circle, Oakville, Ontario, Canada L6H 6G4
 Tel. #: 905-829-1570, Fax. #: 905-829-8050, Email: yhk.ultratech@sympatico.ca, Website: <http://www.ultratech-labs.com>

File #: GLB-006FT
 Jan. 10, 2000

- Assessed by ITI (UK) Competent Body, NVLAP (USA) Accreditation Body & ACA/AUSTEL (Australia)
- Recognized/Listed by FCC (USA), Industry Canada (Canada)
- All test results contained in this engineering test report are traceable to National Institute of Standards and Technology (NIST)

Fundamental Frequency: 164 MHz				
RF Output Power: 7.7 Watts				
Channel Spacing Setting: 25 kHz				
Modulation: 4 Level of FM modulation with internal 19200 b/s Random data				
FREQUENCY (MHz)	RF LEVEL (dBm)	LIMIT (dBm)	MARGIN (dB)	PASS/ FAIL
328.00	-21.1	-13.0	-8.1	PASS
492.00	-32.6	-13.0	-19.6	PASS
1476.00	-31.8	-13.0	-18.8	PASS
No significant rf emissions were scanned from 10 MHz to 2 GHz . All emissions were more than 10 dB below the limits. See Plot #26 in Exhibit 8 of this test report				

Fundamental Frequency: 164 MHz				
RF Output Power: 30.9 Watts				
Channel Spacing Setting: 12.5 kHz				
Modulation: 4 Level of FM modulation with internal 9600 b/s Random data				
FREQUENCY (MHz)	RF LEVEL (dBm)	LIMIT (dBm)	MARGIN (dB)	PASS/ FAIL
No significant rf emissions were scanned from 10 MHz to 2 GHz . All emissions were more than 10 dB below the limits. See Plot #27 in Exhibit 8 of this test report				

Fundamental Frequency: 164 MHz				
RF Output Power: 31.6 Watts				
Channel Spacing Setting: 25 kHz				
Modulation: 4 Level of FM modulation with internal 19200 b/s Random data				
FREQUENCY (MHz)	RF LEVEL (dBm)	LIMIT (dBm)	MARGIN (dB)	PASS/ FAIL
No significant rf emissions were scanned from 10 MHz to 2 GHz . All emissions were more than 10 dB below the limits. See Plot #28 in Exhibit 8 of this test report				

5.9.6. Plots

Please refer to Plot # 17 through # 28 in Exhibit 8 for details of measurements

ULTRATECH GROUP OF LABS

3000 Bristol Circle, Oakville, Ontario, Canada L6H 6G4
 Tel. #: 905-829-1570, Fax. #: 905-829-8050, Email: vhk.ultratech@sympatico.ca, Website: <http://www.ultratech-labs.com>

File #: GLB-006FT
 Jan. 10, 2000

- Assessed by ITI (UK) Competent Body, NVLAP (USA) Accreditation Body & ACA/AUSTEL (Australia)
- Recognized/Listed by FCC (USA), Industry Canada (Canada)
- All test results contained in this engineering test report are traceable to National Institute of Standards and Technology (NIST)

5.10. TRANSMITTER SPURIOUS/HARMONIC RADIATED EMISSIONS @ FCC 90.210

5.10.1. Limits @ FCC 90.210

Emissions shall be attenuated below the mean output power of the transmitter as follows:

FREQUENCY RANGE (MHz)	Maximum Authorized BW (KHz)	CHANNEL SPACING (KHz)	Recommended FREQ. DEVIATION (KHz)	FCC APPLICABLE MASK
150 - 174	20.0	25.0	5.0	• 90.210(c): Mask C – Data
150 - 174	11.25	12.5	2.5	• 90.210(d): Mask D – Voice & Data

5.10.2. Method of Measurements

Please refer to the Exhibit 7, Sec. 7.5 of this test report and ANSI C63-4:1992 for radiated emissions test method.

5.10.3. Test Equipment List

Test Instruments	Manufacturer	Model No.	Serial No.	Frequency Range
Spectrum Analyzer/EMI Receiver	Advantest	R3271	15050203	100 Hz to 32 GHz with external mixer for frequency above 32 GHz
Microwave Amplifier	Hewlett Packard	HP 83017A		1 GHz to 26.5 GHz
Active Loop Antenna	EMCO	6507	8906-1167	1 kHz – 30 MHz
Biconilog Antenna	EMCO	3143	1029	20 MHz to 2 GHz
Horn Antenna	EMCO	3155	9701-5061	1 GHz – 18 GHz
Horn Antenna	EMCO	3160-09	..	18 GHz – 26.5 GHz
Horn Antenna	EMCO	3160-10	..	26.5 GHz – 40 GHz
Mixer	Tektronix	118-0098-00	..	18 GHz – 26.5 GHz
Mixer	Tektronix	119-0098-00	..	26.5 GHz – 40 GHz

ULTRATECH GROUP OF LABS

3000 Bristol Circle, Oakville, Ontario, Canada L6H 6G4
 Tel. #: 905-829-1570, Fax. #: 905-829-8050, Email: yhk.ultratech@sympatico.ca, Website: <http://www.ultratech-labs.com>

File #: GLB-006FT
 Jan. 10, 2000

- Assessed by ITI (UK) Competent Body, NVLAP (USA) Accreditation Body & ACA/AUSTEL (Australia)
- Recognized/Listed by FCC (USA), Industry Canada (Canada)
- All test results contained in this engineering test report are traceable to National Institute of Standards and Technology (NIST)

5.10.4. Test Data

Remarks:

- Based on the conducted measurements in Sec. 5.9.5, there is no significant difference in rf spurious/harmonic emission characteristics between 2 different channel spacing operations. Therefore, the following radiated emissions were performed on the radio set with 12.5 kHz Channel Spacing operation, and the results were compared with the lowest limit of -20 dBm for the worst case.
- The Radiated emissions were performed at 3 meters distance.

5.10.4.1. Near Lowest Frequency (150 MHz)

Fundamental Frequency: 150 MHz							
RF Output Power: 6.0 Watts							
Channel Spacing Setting: 12.5 kHz							
Modulation: 4 Level of FM modulation with internal 9600 b/s random data							
FREQUENCY (MHz)	RF Field Level @3m (dBuV/m)	RF Power Level (dBm)	DETECTOR USED (PEAK/QP)	ANTENNA PLANE (H/V)	LIMIT @3m (dBm)	MARGIN (dB)	PASS/ FAIL
300.00	49.5	-48.0	PEAK	V	-20.0	-28.0	PASS
300.00	50.9	-46.6	PEAK	H	-20.0	-26.6	PASS
450.00	61.7	-35.8	PEAK	V	-20.0	-15.8	PASS
450.00	59.1	-38.4	PEAK	H	-20.0	-18.4	PASS
600.00	42.3	-55.2	PEAK	V	-20.0	-35.2	PASS
600.00	41.7	-55.8	PEAK	H	-20.0	-35.8	PASS
750.00	54.4	-43.1	PEAK	V	-20.0	-23.1	PASS
750.00	54.6	-42.9	PEAK	H	-20.0	-22.9	PASS
900.00	50.4	-47.1	PEAK	V	-20.0	-27.1	PASS
900.00	50.7	-46.8	PEAK	H	-20.0	-26.8	PASS
1050.00	41.3	-56.2	PEAK	V	-20.0	-36.2	PASS
1050.00	42.8	-54.7	PEAK	H	-20.0	-34.7	PASS
1200.00	48.1	-49.4	PEAK	V	-20.0	-29.4	PASS
1200.00	47.4	-50.1	PEAK	H	-20.0	-30.1	PASS
1350.00	43.9	-53.6	PEAK	V	-20.0	-33.6	PASS
1350.00	43.9	-53.6	PEAK	H	-20.0	-33.6	PASS
1500.00	52.2	-45.3	PEAK	V	-20.0	-25.3	PASS
1500.00	48.1	-49.4	PEAK	H	-20.0	-29.4	PASS
The emissions were scanned from 10 MHz to 1.5 GHz and all emissions less 40 dB below the limits were recorded.							

ULTRATECH GROUP OF LABS

3000 Bristol Circle, Oakville, Ontario, Canada L6H 6G4
 Tel. #: 905-829-1570, Fax. #: 905-829-8050, Email: vhk.ultratech@sympatico.ca, Website: <http://www.ultratech-labs.com>

File #: GLB-006FT
 Jan. 10, 2000

- Assessed by ITI (UK) Competent Body, NVLAP (USA) Accreditation Body & ACA/AUSTEL (Australia)
- Recognized/Listed by FCC (USA), Industry Canada (Canada)
- All test results contained in this engineering test report are traceable to National Institute of Standards and Technology (NIST)

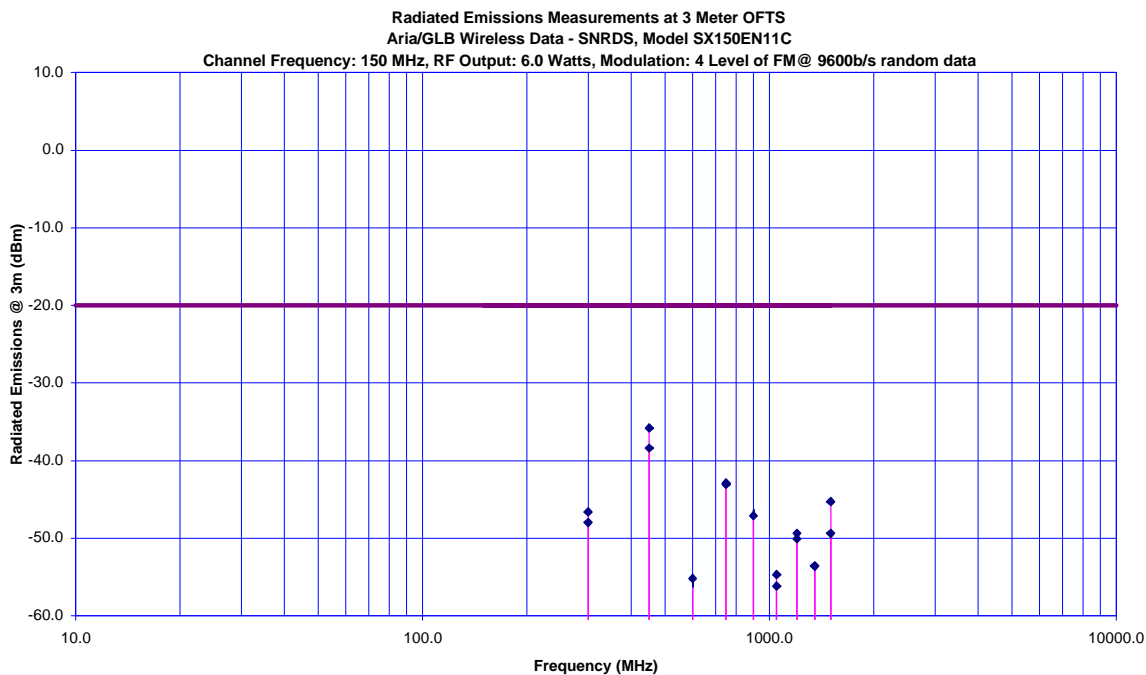

ULTRATECH GROUP OF LABS

3000 Bristol Circle, Oakville, Ontario, Canada L6H 6G4
Tel. #: 905-829-1570, Fax. #: 905-829-8050, Email: yhk.ultratech@sympatico.ca, Website: <http://www.ultratech-labs.com>

File #: GLB-006FT
Jan. 10, 2000

- Assessed by ITI (UK) Competent Body, NVLAP (USA) Accreditation Body & ACA/AUSTEL (Australia)
- Recognized/Listed by FCC (USA), Industry Canada (Canada)
- All test results contained in this engineering test report are traceable to National Institute of Standards and Technology (NIST)

Fundamental Frequency: 150 MHz RF Output Power: 35.5 Watts Channel Spacing Setting: 12.5 kHz Modulation: 4 Level of FM modulation with internal 9600 b/s random data							
FREQUENCY (MHz)	RF Field Level @3m (dBuV/m)	RF Power Level (dBm)	DETECTOR USED (PEAK/QP)	ANTENNA PLANE (H/V)	LIMIT @3m (dBm)	MARGIN (dB)	PASS/ FAIL
300.00	55.9	-41.6	PEAK	V	-20.0	-21.6	PASS
300.00	54.2	-43.3	PEAK	H	-20.0	-23.3	PASS
450.00	54.7	-42.8	PEAK	V	-20.0	-22.8	PASS
450.00	56.8	-40.7	PEAK	H	-20.0	-20.7	PASS
600.00	60.1	-37.4	PEAK	V	-20.0	-17.4	PASS
600.00	66.5	-31.0	PEAK	H	-20.0	-11.0	PASS
750.00	46.9	-50.6	PEAK	V	-20.0	-30.6	PASS
750.00	50.9	-46.6	PEAK	H	-20.0	-26.6	PASS
900.00	49.5	-48.0	PEAK	V	-20.0	-28.0	PASS
900.00	49.2	-48.3	PEAK	H	-20.0	-28.3	PASS
1050.00	63.0	-34.5	PEAK	V	-20.0	-14.5	PASS
1050.00	64.7	-32.8	PEAK	H	-20.0	-12.8	PASS
1200.00	65.5	-32.0	PEAK	V	-20.0	-12.0	PASS
1200.00	58.6	-38.9	PEAK	H	-20.0	-18.9	PASS
1350.00	47.6	-49.9	PEAK	V	-20.0	-29.9	PASS
1350.00	46.5	-51.0	PEAK	H	-20.0	-31.0	PASS
1500.00	47.8	-49.7	PEAK	V	-20.0	-29.7	PASS
1500.00	46.2	-51.3	PEAK	H	-20.0	-31.3	PASS
The emissions were scanned from 10 MHz to 1.5 GHz and all emissions less 40 dB below the limits were recorded.							

ULTRATECH GROUP OF LABS

3000 Bristol Circle, Oakville, Ontario, Canada L6H 6G4
 Tel. #: 905-829-1570, Fax. #: 905-829-8050, Email: yhk.ultratech@sympatico.ca, Website: <http://www.ultratech-labs.com>

File #: GLB-006FT
 Jan. 10, 2000

- Assessed by ITI (UK) Competent Body, NVLAP (USA) Accreditation Body & ACA/AUSTEL (Australia)
- Recognized/Listed by FCC (USA), Industry Canada (Canada)
- All test results contained in this engineering test report are traceable to National Institute of Standards and Technology (NIST)

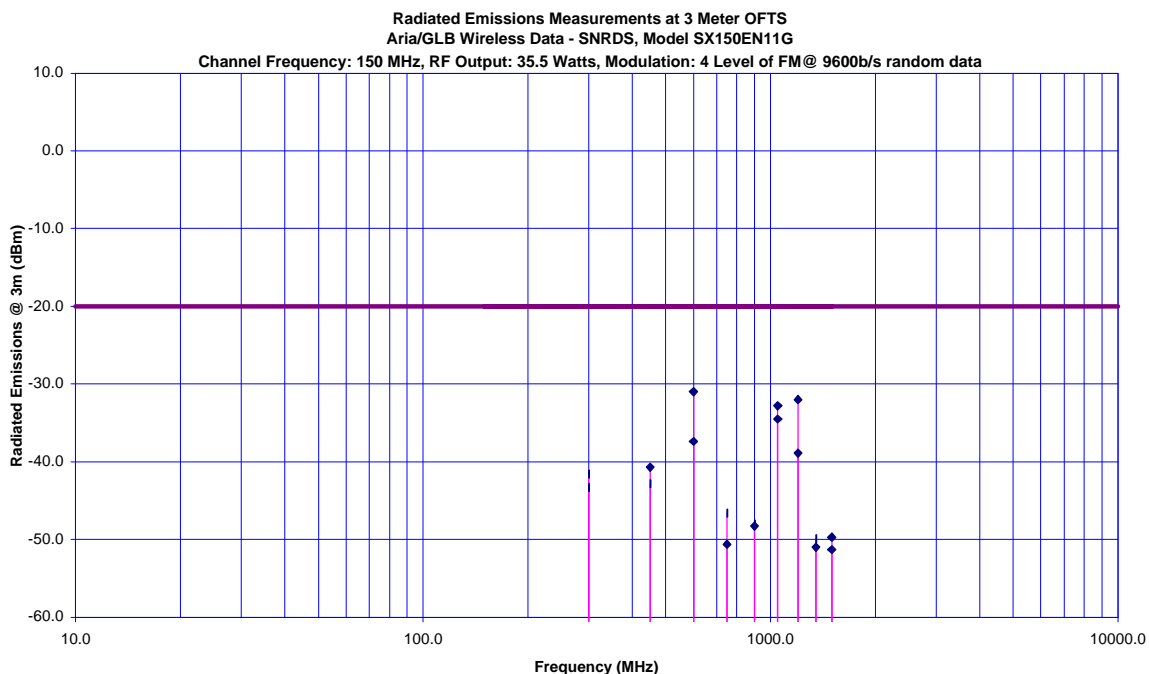

ULTRATECH GROUP OF LABS

3000 Bristol Circle, Oakville, Ontario, Canada L6H 6G4
Tel. #: 905-829-1570, Fax. #: 905-829-8050, Email: vhk.ultratech@sympatico.ca, Website: <http://www.ultratech-labs.com>

File #: GLB-006FT
Jan. 10, 2000

- Assessed by ITI (UK) Competent Body, NVLAP (USA) Accreditation Body & ACA/AUSTEL (Australia)
- Recognized/Listed by FCC (USA), Industry Canada (Canada)
- All test results contained in this engineering test report are traceable to National Institute of Standards and Technology (NIST)

5.10.4.2. Near Middle Frequency (157.0000 MHz)

Fundamental Frequency: 157 MHz							
RF Output Power: 34.5 Watts							
Channel Spacing Setting: 12.5 kHz							
Modulation: 4 Level of FM modulation with internal 9600 b/s random data							
FREQUENCY (MHz)	RF Field Level @3m (dBuV/m)	RF Power Level (dBm)	DETECTOR USED (PEAK/QP)	ANTENNA PLANE (H/V)	LIMIT @3m (dBm)	MARGIN (dB)	PASS/ FAIL
314.00	49.3	-48.2	PEAK	V	-20.0	-28.2	PASS
314.00	52.7	-44.8	PEAK	H	-20.0	-24.8	PASS
471.00	59.6	-37.9	PEAK	V	-20.0	-17.9	PASS
471.00	61.0	-36.5	PEAK	H	-20.0	-16.5	PASS
628.00	60.3	-37.2	PEAK	V	-20.0	-17.2	PASS
628.00	64.7	-32.8	PEAK	H	-20.0	-12.8	PASS
785.00	53.3	-44.2	PEAK	V	-20.0	-24.2	PASS
785.00	55.8	-41.7	PEAK	H	-20.0	-21.7	PASS
942.00	47.8	-49.7	PEAK	V	-20.0	-29.7	PASS
942.00	50.3	-47.2	PEAK	H	-20.0	-27.2	PASS
1099.00	65.5	-32.0	PEAK	V	-20.0	-12.0	PASS
1099.00	59.1	-38.4	PEAK	H	-20.0	-18.4	PASS
1256.00	59.8	-37.7	PEAK	V	-20.0	-17.7	PASS
1256.00	59.7	-37.8	PEAK	H	-20.0	-17.8	PASS
1413.00	50.5	-47.0	PEAK	V	-20.0	-27.0	PASS
1413.00	51.6	-45.9	PEAK	H	-20.0	-25.9	PASS
1570.00	46.6	-50.9	PEAK	V	-20.0	-30.9	PASS
1570.00	51.7	-45.8	PEAK	H	-20.0	-25.8	PASS
The emissions were scanned from 10 MHz to 2 GHz and all emissions less 40 dB below the limits were recorded.							

ULTRATECH GROUP OF LABS

3000 Bristol Circle, Oakville, Ontario, Canada L6H 6G4
 Tel. #: 905-829-1570, Fax. #: 905-829-8050, Email: yhk.ultratech@sympatico.ca, Website: <http://www.ultratech-labs.com>

File #: GLB-006FT
 Jan. 10, 2000

- Assessed by ITI (UK) Competent Body, NVLAP (USA) Accreditation Body & ACA/AUSTEL (Australia)
- Recognized/Listed by FCC (USA), Industry Canada (Canada)
- All test results contained in this engineering test report are traceable to National Institute of Standards and Technology (NIST)

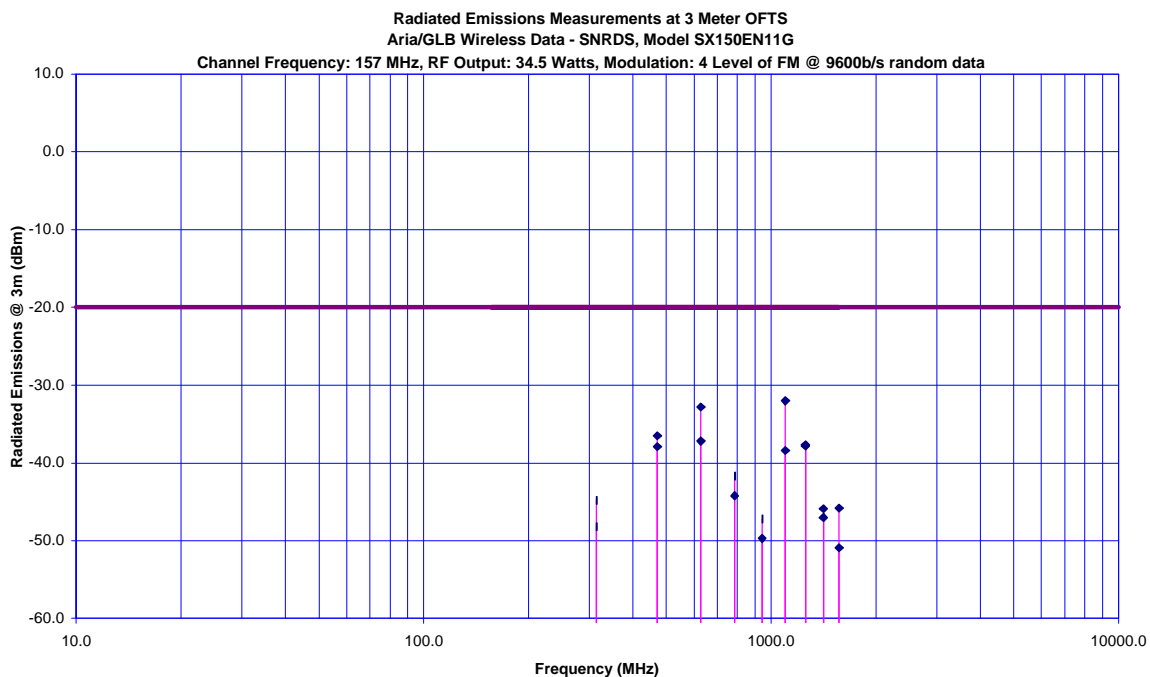

ULTRATECH GROUP OF LABS

3000 Bristol Circle, Oakville, Ontario, Canada L6H 6G4
Tel. #: 905-829-1570, Fax. #: 905-829-8050, Email: vhk.ultratech@sympatico.ca, Website: <http://www.ultratech-labs.com>

File #: GLB-006FT
Jan. 10, 2000

- Assessed by ITI (UK) Competent Body, NVLAP (USA) Accreditation Body & ACA/AUSTEL (Australia)
- Recognized/Listed by FCC (USA), Industry Canada (Canada)
- All test results contained in this engineering test report are traceable to National Institute of Standards and Technology (NIST)

Fundamental Frequency: 157 MHz							
RF Output Power: 7.0 Watts							
Channel Spacing Setting: 12.5 kHz							
Modulation: 4 Level of FM modulation with internal 9600 b/s random data							
FREQUENCY (MHz)	RF Field Level @3m (dBuV/m)	RF Power Level (dBm)	DETECTOR USED (PEAK/QP)	ANTENNA PLANE (H/V)	LIMIT @3m (dBm)	MARGIN (dB)	PASS/ FAIL
314.00	55.8	-41.7	PEAK	V	-20.0	-21.7	PASS
314.00	55.9	-41.6	PEAK	H	-20.0	-21.6	PASS
471.00	47.7	-49.8	PEAK	V	-20.0	-29.8	PASS
471.00	51.9	-45.6	PEAK	H	-20.0	-25.6	PASS
628.00	45.8	-51.7	PEAK	V	-20.0	-31.7	PASS
628.00	47.2	-50.3	PEAK	H	-20.0	-30.3	PASS
785.00	52.6	-44.9	PEAK	V	-20.0	-24.9	PASS
785.00	52.5	-45.0	PEAK	H	-20.0	-25.0	PASS
942.00	48.0	-49.5	PEAK	V	-20.0	-29.5	PASS
942.00	50.5	-47.0	PEAK	H	-20.0	-27.0	PASS
1099.00	49.7	-47.8	PEAK	V	-20.0	-27.8	PASS
1099.00	47.1	-50.4	PEAK	H	-20.0	-30.4	PASS
1256.00	47.8	-49.7	PEAK	V	-20.0	-29.7	PASS
1256.00	44.0	-53.5	PEAK	H	-20.0	-33.5	PASS
1413.00	52.7	-44.8	PEAK	V	-20.0	-24.8	PASS
1413.00	48.1	-49.4	PEAK	H	-20.0	-29.4	PASS
1570.00	52.7	-44.8	PEAK	V	-20.0	-24.8	PASS
1570.00	52.9	-44.6	PEAK	H	-20.0	-24.6	PASS
The emissions were scanned from 10 MHz to 1.57 GHz and all emissions less 40 dB below the limits were recorded.							

ULTRATECH GROUP OF LABS

3000 Bristol Circle, Oakville, Ontario, Canada L6H 6G4
 Tel. #: 905-829-1570, Fax. #: 905-829-8050, Email: yhk.ultratech@sympatico.ca, Website: <http://www.ultratech-labs.com>

File #: GLB-006FT
 Jan. 10, 2000

- Assessed by ITI (UK) Competent Body, NVLAP (USA) Accreditation Body & ACA/AUSTEL (Australia)
- Recognized/Listed by FCC (USA), Industry Canada (Canada)
- All test results contained in this engineering test report are traceable to National Institute of Standards and Technology (NIST)

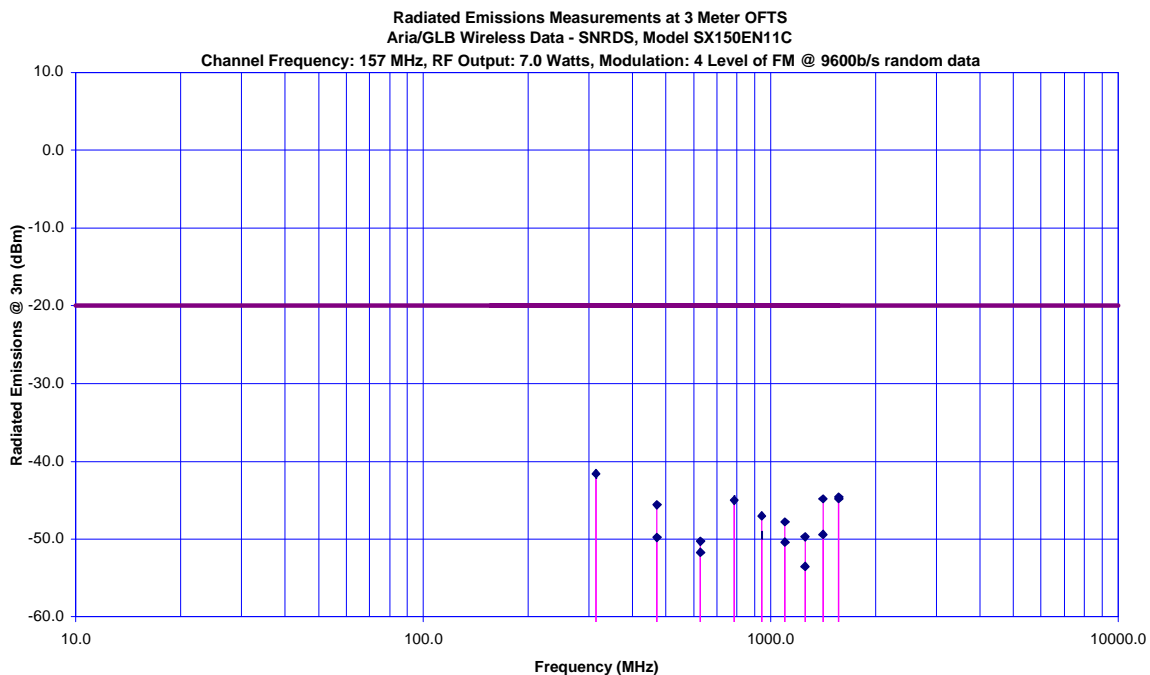

ULTRATECH GROUP OF LABS

3000 Bristol Circle, Oakville, Ontario, Canada L6H 6G4
Tel. #: 905-829-1570, Fax. #: 905-829-8050, Email: vhk.ultratech@sympatico.ca, Website: <http://www.ultratech-labs.com>

File #: GLB-006FT
Jan. 10, 2000

- Assessed by ITI (UK) Competent Body, NVLAP (USA) Accreditation Body & ACA/AUSTEL (Australia)
- Recognized/Listed by FCC (USA), Industry Canada (Canada)
- All test results contained in this engineering test report are traceable to National Institute of Standards and Technology (NIST)

5.10.4.3. Near Highest Frequency (164.0000 MHz)

Fundamental Frequency: 164 MHz							
RF Output Power: 31.6 Watts							
Channel Spacing Setting: 12.5 kHz							
Modulation: 4 Level of FM modulation with internal 9600 b/s random data							
FREQUENCY (MHz)	RF Field Level @3m (dBuV/m)	RF Power Level (dBm)	DETECTOR USED (PEAK/QP)	ANTENNA PLANE (H/V)	LIMIT @3m (dBm)	MARGIN (dB)	PASS/ FAIL
328.00	43.7	-53.8	PEAK	V	-20.0	-33.8	PASS
328.00	51.3	-46.2	PEAK	H	-20.0	-26.2	PASS
492.00	63.4	-34.1	PEAK	V	-20.0	-14.1	PASS
492.00	67.9	-29.6	PEAK	H	-20.0	-9.6	PASS
656.00	66.6	-30.9	PEAK	V	-20.0	-10.9	PASS
656.00	72.3	-25.2	PEAK	H	-20.0	-5.2	PASS
820.00	46.1	-51.4	PEAK	V	-20.0	-31.4	PASS
820.00	47.6	-49.9	PEAK	H	-20.0	-29.9	PASS
984.00	55.8	-41.7	PEAK	V	-20.0	-21.7	PASS
984.00	58.4	-39.1	PEAK	H	-20.0	-19.1	PASS
1148.00	64.2	-33.3	PEAK	V	-20.0	-13.3	PASS
1148.00	63.6	-33.9	PEAK	H	-20.0	-13.9	PASS
1312.00	45.3	-52.2	PEAK	V	-20.0	-32.2	PASS
1312.00	46.8	-50.7	PEAK	H	-20.0	-30.7	PASS
1476.00	46.6	-50.9	PEAK	V	-20.0	-30.9	PASS
1476.00	45.2	-52.3	PEAK	H	-20.0	-32.3	PASS
1640.00	48.8	-48.7	PEAK	V	-20.0	-28.7	PASS
1640.00	52.2	-45.3	PEAK	H	-20.0	-25.3	PASS
The emissions were scanned from 10 MHz to 2 GHz and all emissions less 40 dB below the limits were recorded.							

ULTRATECH GROUP OF LABS

3000 Bristol Circle, Oakville, Ontario, Canada L6H 6G4
 Tel. #: 905-829-1570, Fax. #: 905-829-8050, Email: vhk.ultratech@sympatico.ca, Website: <http://www.ultratech-labs.com>

File #: GLB-006FT
 Jan. 10, 2000

- Assessed by ITI (UK) Competent Body, NVLAP (USA) Accreditation Body & ACA/AUSTEL (Australia)
- Recognized/Listed by FCC (USA), Industry Canada (Canada)
- All test results contained in this engineering test report are traceable to National Institute of Standards and Technology (NIST)

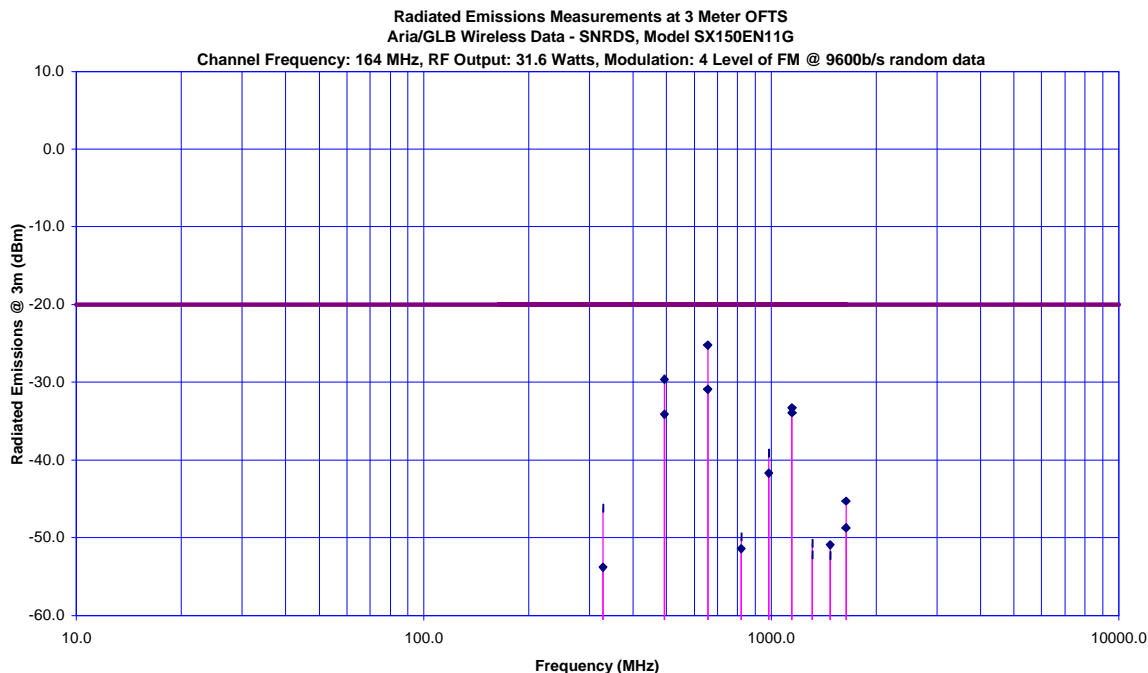

ULTRATECH GROUP OF LABS

3000 Bristol Circle, Oakville, Ontario, Canada L6H 6G4
Tel. #: 905-829-1570, Fax. #: 905-829-8050, Email: vhk.ultratech@sympatico.ca, Website: <http://www.ultratech-labs.com>

File #: GLB-006FT
Jan. 10, 2000

- Assessed by ITI (UK) Competent Body, NVLAP (USA) Accreditation Body & ACA/AUSTEL (Australia)
- Recognized/Listed by FCC (USA), Industry Canada (Canada)
- All test results contained in this engineering test report are traceable to National Institute of Standards and Technology (NIST)

Fundamental Frequency: 164 MHz							
RF Output Power: 7.7 Watts							
Channel Spacing Setting: 12.5 kHz							
Modulation: 4 Level of FM modulation with internal 9600 b/s random data							
FREQUENCY (MHz)	RF Field Level @3m (dBuV/m)	RF Power Level (dBm)	DETECTOR USED (PEAK/QP)	ANTENNA PLANE (H/V)	LIMIT @3m (dBm)	MARGIN (dB)	PASS/ FAIL
328.00	52.2	-45.3	PEAK	V	-20.0	-25.3	PASS
328.00	58.0	-39.5	PEAK	H	-20.0	-19.5	PASS
492.00	50.7	-46.8	PEAK	V	-20.0	-26.8	PASS
492.00	52.1	-45.4	PEAK	H	-20.0	-25.4	PASS
656.00	49.3	-48.2	PEAK	V	-20.0	-28.2	PASS
656.00	49.8	-47.7	PEAK	H	-20.0	-27.7	PASS
820.00	55.9	-41.6	PEAK	V	-20.0	-21.6	PASS
820.00	57.7	-39.8	PEAK	H	-20.0	-19.8	PASS
984.00	59.6	-37.9	PEAK	V	-20.0	-17.9	PASS
984.00	61.7	-35.8	PEAK	H	-20.0	-15.8	PASS
1148.00	49.9	-47.6	PEAK	V	-20.0	-27.6	PASS
1148.00	48.4	-49.1	PEAK	H	-20.0	-29.1	PASS
1312.00	50.2	-47.3	PEAK	V	-20.0	-27.3	PASS
1312.00	45.8	-51.7	PEAK	H	-20.0	-31.7	PASS
1476.00	48.3	-49.2	PEAK	V	-20.0	-29.2	PASS
1476.00	54.2	-43.3	PEAK	H	-20.0	-23.3	PASS
1640.00	63.5	-34.0	PEAK	V	-20.0	-14.0	PASS
1640.00	62.2	-35.3	PEAK	H	-20.0	-15.3	PASS
The emissions were scanned from 10 MHz to 2 GHz and all emissions less 40 dB below the limits were recorded.							

ULTRATECH GROUP OF LABS

3000 Bristol Circle, Oakville, Ontario, Canada L6H 6G4
 Tel. #: 905-829-1570, Fax. #: 905-829-8050, Email: vhk.ultratech@sympatico.ca, Website: <http://www.ultratech-labs.com>

File #: GLB-006FT
 Jan. 10, 2000

- Assessed by ITI (UK) Competent Body, NVLAP (USA) Accreditation Body & ACA/AUSTEL (Australia)
- Recognized/Listed by FCC (USA), Industry Canada (Canada)
- All test results contained in this engineering test report are traceable to National Institute of Standards and Technology (NIST)

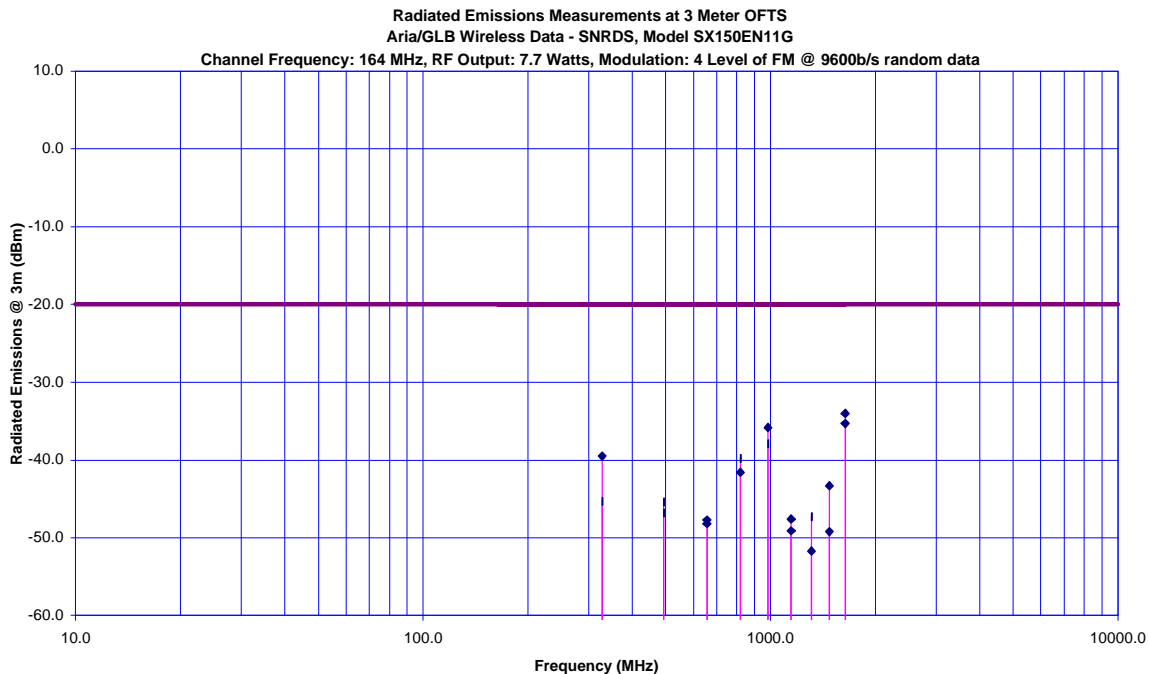

ULTRATECH GROUP OF LABS

3000 Bristol Circle, Oakville, Ontario, Canada L6H 6G4
Tel. #: 905-829-1570, Fax. #: 905-829-8050, Email: yhk.ultratech@sympatico.ca, Website: <http://www.ultratech-labs.com>

File #: GLB-006FT
Jan. 10, 2000

- Assessed by ITI (UK) Competent Body, NVLAP (USA) Accreditation Body & ACA/AUSTEL (Australia)
- Recognized/Listed by FCC (USA), Industry Canada (Canada)
- All test results contained in this engineering test report are traceable to National Institute of Standards and Technology (NIST)

5.10.5. Photographs of Test Setup

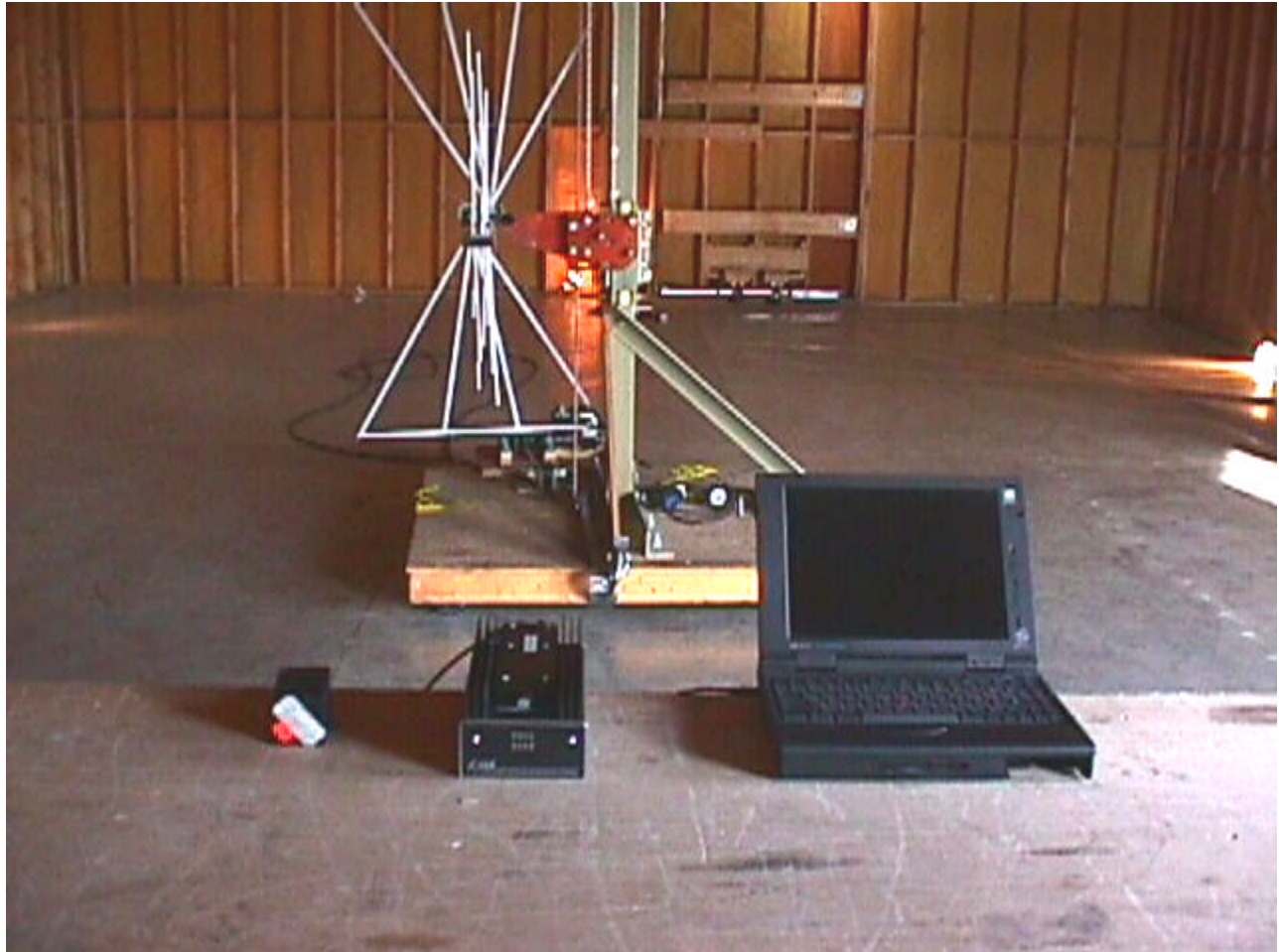

ULTRATECH GROUP OF LABS

3000 Bristol Circle, Oakville, Ontario, Canada L6H 6G4
Tel. #: 905-829-1570, Fax. #: 905-829-8050, Email: yhk.ultratech@sympatico.ca, Website: <http://www.ultratech-labs.com>

File #: GLB-006FT
Jan. 10, 2000

- Assessed by ITI (UK) Competent Body, NVLAP (USA) Accreditation Body & ACA/AUSTEL (Australia)
- Recognized/Listed by FCC (USA), Industry Canada (Canada)
- All test results contained in this engineering test report are traceable to National Institute of Standards and Technology (NIST)



ULTRATECH GROUP OF LABS

3000 Bristol Circle, Oakville, Ontario, Canada L6H 6G4
Tel. #: 905-829-1570, Fax. #: 905-829-8050, Email: yhk.ultratech@sympatico.ca, Website: <http://www.ultratech-labs.com>

File #: GLB-006FT
Jan. 10, 2000

- Assessed by ITI (UK) Competent Body, NVLAP (USA) Accreditation Body & ACA/AUSTEL (Australia)
- Recognized/Listed by FCC (USA), Industry Canada (Canada)
- All test results contained in this engineering test report are traceable to National Institute of Standards and Technology (NIST)

5.11. TRANSIENT FREQUENCY BEHAVIOR @ 90.214

5.11.1. Limits

Transient frequencies must be within the maximum frequency difference limits during the time intervals indicated:

Transient Frequency Behavior for equipment Designed to Operate on 12.5 KHz Channels

Time Interval ^{1,2}	All Equipment	
	Maximum Frequency Difference ³	150 - 174 MHz
t1 ⁴	± 12.5 KHz	5.0 ms
t2	± 6.25 KHz	20.0 ms
t3 ⁴	± 12.5 KHz	5.0 ms

Transient Frequency Behavior for equipment Designed to Operate on 25 KHz Channels

Time Interval ^{1,2}	All Equipment	
	Maximum Frequency Difference ³	150 - 174 MHz
t1 ⁴	± 25 KHz	5.0 ms
t2	± 12.5 KHz	20.0 ms
t3 ⁴	± 25 KHz	5.0 ms

- (1) ton: the instant when a 1 KHz test signal is completely suppressed, including any capture time due to phasing.
 t1: time period immediately after ton
 t2: time period after t1
 t3: time period from the instant when the transmitter is turned off until toff
 toff: the instant when the 1 KHz test signal starts to rise.
- (2) During the time from the end of t2 to the beginning of t3, the frequency difference must not exceed the limits specified in @ 90.213
- (3) Difference between the actual transmitter frequency and assigned transmitter frequency.
- (4) If the transmitter carrier output power rating is 6 watts or less, the frequency difference during this time period may exceed the maximum frequency difference for this time period.

5.11.2. Method of Measurements

Refer to Exhibit 7, Sec. 7.6 of this test report and ANSI/TIA/EIA - 603 - 1992, Sec. 2.2.19, Page 83

ULTRATECH GROUP OF LABS

3000 Bristol Circle, Oakville, Ontario, Canada L6H 6G4
 Tel. #: 905-829-1570, Fax. #: 905-829-8050, Email: vhk.ultratech@sympatico.ca, Website: <http://www.ultratech-labs.com>

File #: GLB-006FT
 Jan. 10, 2000

- Assessed by ITI (UK) Competent Body, NVLAP (USA) Accreditation Body & ACA/AUSTEL (Australia)
- Recognized/Listed by FCC (USA), Industry Canada (Canada)
- All test results contained in this engineering test report are traceable to National Institute of Standards and Technology (NIST)

5.11.3. Test Equipment List

Test Instruments	Manufacturer	Model No.	Serial No.	Frequency Range
RF Synthesized Signal Generator	Fluke	6061A	...	10 kHz – 1GHz 13 dBm output max. @ 50 Ohms
Communication Analyzer (Test Receiver)	Rohde & Schwarz	SMFP2	879988/057	400 GHz including SINAD, S/N, Modulation meters, AF & RF signal generators and etc....
Network Combiner	Mini-circuit	15542	...	DC to 22 GHz (7 dB insertion loss)
Digital Storage Scope	Phillips	3320A	DQ 646	DC - 5 MHz
67297 RF Detector,	Herotex	DZ122-553	63400	..

ULTRATECH GROUP OF LABS

3000 Bristol Circle, Oakville, Ontario, Canada L6H 6G4
 Tel. #: 905-829-1570, Fax. #: 905-829-8050, Email: vhk.ultratech@sympatico.ca, Website: <http://www.ultratech-labs.com>

File #: GLB-006FT
 Jan. 10, 2000

- Assessed by ITI (UK) Competent Body, NVLAP (USA) Accreditation Body & ACA/AUSTEL (Australia)
- Recognized/Listed by FCC (USA), Industry Canada (Canada)
- All test results contained in this engineering test report are traceable to National Institute of Standards and Technology (NIST)

5.11.4. Test Arrangement

The following drawings show details of the test setup for radiated emissions measurements

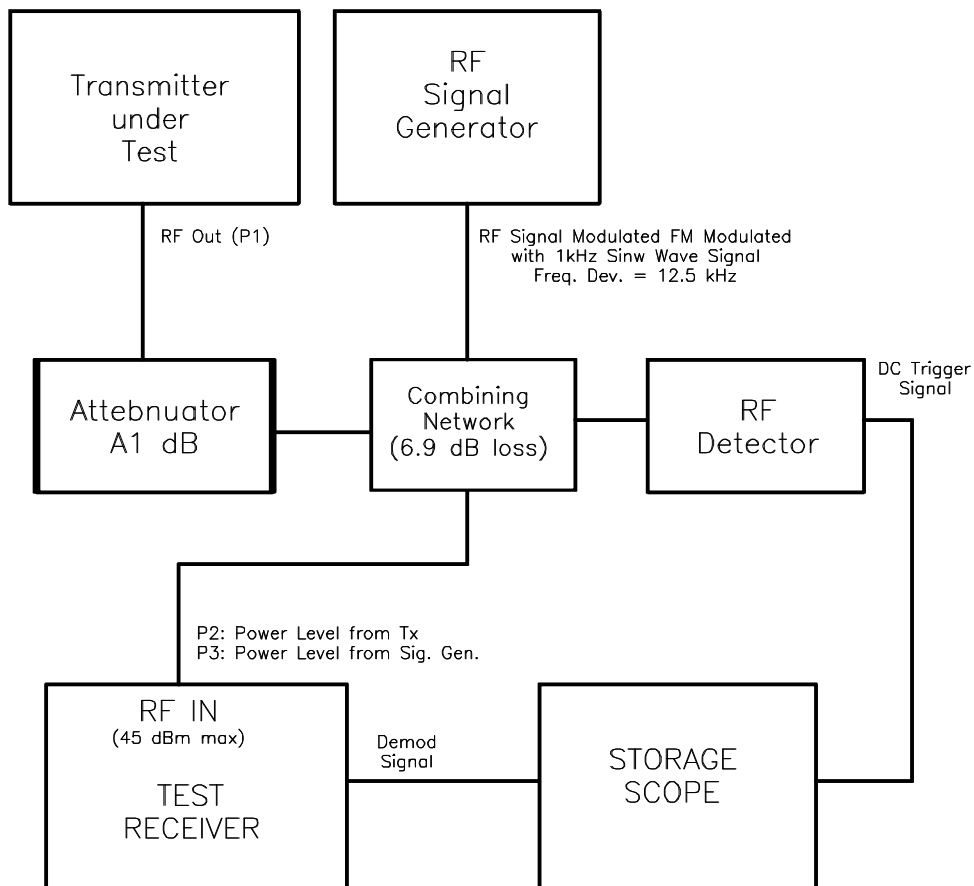

ULTRATECH GROUP OF LABS

3000 Bristol Circle, Oakville, Ontario, Canada L6H 6G4
Tel. #: 905-829-1570, Fax. #: 905-829-8050, Email: vhk.ultratech@sympatico.ca, Website: <http://www.ultratech-labs.com>

File #: GLB-006FT
Jan. 10, 2000

- Assessed by ITI (UK) Competent Body, NVLAP (USA) Accreditation Body & ACA/AUSTEL (Australia)
- Recognized/Listed by FCC (USA), Industry Canada (Canada)
- All test results contained in this engineering test report are traceable to National Institute of Standards and Technology (NIST)

5.11.5. Test Data

5.11.5.1. Model Tested: SX150EN11C, RF Output Power: 7.7 Watts, Channel Spacing: 12.5 KHz

- Attenuator A1 = 40 dB (Measured attenuation from P1 to P2 = 48.5 dB)
- Measured Transmitter RF Output P1: 38.9 dBm
- Measured Transmitter RF Output P2 @ Standard Test Receiver (Max. RF IN: 45 dBm): -9.6 dBm
- Measured Signal generator Output P3 @ Standard Test Receiver (Max. RF IN: 45 dBm): -30 dBm

5.11.5.1.1. Test Configuration #1: Unmodulated

Time Interval	Transient Frequency	Transient Frequency Limit
t1 (5 mS) SWITCH ON CONDITION	+3.2 kHz	12.5 kHz
t2 (20 mS) SWITCH ON CONDITION	0.0 Hz	6.25 kHz
After t2 (5 mS) SWITCH ON CONDITION	0.0 Hz	FCC Limit = ± 375 Hz (0.00025% @150 MHz)
Before t3 (5 mS) SWITCH OFF CONDITION	0.0 Hz	FCC Limit = ± 375 Hz (0.00025% @150 MHz)
t3 (5 mS) SWITCH OFF CONDITION	0.0 Hz	12.5 kHz

5.11.5.1.2. Test Configuration #2: 4 Level of FM modulation with internal 9600 b/s random data

Time Interval	Transient Frequency	Transient Frequency Limit
t1 (5 mS) SWITCH ON CONDITION	+0.0 kHz	12.5 kHz
t2 (20 mS) SWITCH ON CONDITION	0.0 Hz	6.25 kHz
After t2 (5 mS) SWITCH ON CONDITION	0.0 Hz	FCC Limit = ± 375 Hz (0.00025% @150 MHz)
Before t3 (5 mS) SWITCH OFF CONDITION	0.0 Hz	FCC Limit = ± 375 Hz (0.00025% @150 MHz)
t3 (5 mS) SWITCH OFF CONDITION	0.0 Hz	12.5 kHz

ULTRATECH GROUP OF LABS

3000 Bristol Circle, Oakville, Ontario, Canada L6H 6G4
 Tel. #: 905-829-1570, Fax. #: 905-829-8050, Email: vhk.ultratech@sympatico.ca, Website: <http://www.ultratech-labs.com>

File #: GLB-006FT
 Jan. 10, 2000

- Assessed by ITI (UK) Competent Body, NVLAP (USA) Accreditation Body & ACA/AUSTEL (Australia)
- Recognized/Listed by FCC (USA), Industry Canada (Canada)
- All test results contained in this engineering test report are traceable to National Institute of Standards and Technology (NIST)

5.11.5.2. Model Tested: SX150EN11C, RF Output Power: 7.7 Watts, Channel Spacing: 25 KHz

- Attenuator A1 = 40 dB (Measured attenuation from P1 to P2 = 48.5 dB)
- Measured Transmitter RF Output P1: 38.9 dBm
- Measured Transmitter RF Output P2 @ Standard Test Receiver (Max. RF IN: 45 dBm): -9.6 dBm
- Measured Signal generator Output P3 @ Standard Test Receiver (Max. RF IN: 45 dBm): -30 dBm

5.11.5.2.1. Test Configuration #1: Unmodulated

Time Interval	Transient Frequency	Transient Frequency Limit
t1 (5 mS) SWITCH ON CONDITION	+6.3 kHz	25 kHz
t2 (20 mS) SWITCH ON CONDITION	0.0 Hz	12.5 kHz
After t2 (5 mS) SWITCH ON CONDITION	0.0 Hz	FCC Limit = ± 750 Hz (0.0005% @ 150 MHz)
Before t3 (5 mS) SWITCH OFF CONDITION	0.0 Hz	FCC Limit = ± 750 Hz (0.0005% @ 150 MHz)
t3 (5 mS) SWITCH OFF CONDITION	0.0 Hz	25 kHz

5.11.5.2.2. Test Configuration #2: 4 Level of FM modulation with internal 9600 b/s random data

Time Interval	Transient Frequency	Transient Frequency Limit
t1 (5 mS) SWITCH ON CONDITION	+21.9 kHz	25 kHz
t2 (20 mS) SWITCH ON CONDITION	0.0 Hz	12.5 kHz
After t2 (5 mS) SWITCH ON CONDITION	0.0 Hz	FCC Limit = ± 750 Hz (0.0005% @ 150 MHz)
Before t3 (5 mS) SWITCH OFF CONDITION	0.0 Hz	FCC Limit = ± 750 Hz (0.0005% @ 150 MHz)
t3 (5 mS) SWITCH OFF CONDITION	0.0 Hz	25 kHz

ULTRATECH GROUP OF LABS

3000 Bristol Circle, Oakville, Ontario, Canada L6H 6G4
 Tel. #: 905-829-1570, Fax. #: 905-829-8050, Email: yhk.ultratech@sympatico.ca, Website: <http://www.ultratech-labs.com>

File #: GLB-006FT
 Jan. 10, 2000

- Assessed by ITI (UK) Competent Body, NVLAP (USA) Accreditation Body & ACA/AUSTEL (Australia)
- Recognized/Listed by FCC (USA), Industry Canada (Canada)
- All test results contained in this engineering test report are traceable to National Institute of Standards and Technology (NIST)

5.11.5.3. Model Tested: SX150EN11G, RF Output Power: 35.5 Watts, Channel Spacing: 12.5 KHz

- Attenuator A1 = 40 dB (Measured attenuation from P1 to P2 = 48.5 dB)
- Measured Transmitter RF Output P1: 45.5 dBm
- Measured Transmitter RF Output P2 @ Standard Test Receiver (Max. RF IN: 45 dBm): -3 dBm
- Measured Signal generator Output P3 @ Standard Test Receiver (Max. RF IN: 45 dBm): -17 dBm

5.11.5.3.1. Test Configuration #1: Unmodulated

Time Interval	Transient Frequency	Transient Frequency Limit
t1 (5 mS) SWITCH ON CONDITION	+4.1 kHz	12.5 kHz
t2 (20 mS) SWITCH ON CONDITION	0.0 Hz	6.25 kHz
After t2 (5 mS) SWITCH ON CONDITION	0.0 Hz	FCC Limit = ± 375 Hz (0.00025% @ 150 MHz)
Before t3 (5 mS) SWITCH OFF CONDITION	0.0 Hz	FCC Limit = ± 375 Hz (0.00025% @ 150 MHz)
t3 (5 mS) SWITCH OFF CONDITION	0.0 Hz	12.5 kHz

5.11.5.3.2. Test Configuration #2: 4 Level of FM modulation with internal 9600 b/s random data

Time Interval	Transient Frequency	Transient Frequency Limit
t1 (5 mS) SWITCH ON CONDITION	+11.2 kHz	12.5 kHz
t2 (20 mS) SWITCH ON CONDITION	0.0 Hz	6.25 kHz
After t2 (5 mS) SWITCH ON CONDITION	0.0 Hz	FCC Limit = ± 375 Hz (0.00025% @ 150 MHz)
Before t3 (5 mS) SWITCH OFF CONDITION	0.0 Hz	FCC Limit = ± 375 Hz (0.00025% @ 150 MHz)
t3 (5 mS) SWITCH OFF CONDITION	0.0 Hz	12.5 kHz

ULTRATECH GROUP OF LABS

3000 Bristol Circle, Oakville, Ontario, Canada L6H 6G4
 Tel. #: 905-829-1570, Fax. #: 905-829-8050, Email: yhk.ultratech@sympatico.ca, Website: <http://www.ultratech-labs.com>

File #: GLB-006FT
 Jan. 10, 2000

- Assessed by ITI (UK) Competent Body, NVLAP (USA) Accreditation Body & ACA/AUSTEL (Australia)
- Recognized/Listed by FCC (USA), Industry Canada (Canada)
- All test results contained in this engineering test report are traceable to National Institute of Standards and Technology (NIST)

5.11.5.4. Model Tested: SX150EN11C, RF Output Power: 35.5 Watts, Channel Spacing: 25 KHz

- Attenuator A1 = 40 dB (Measured attenuation from P1 to P2 = 48.5 dB)
- Measured Transmitter RF Output P1: 45.5 dBm
- Measured Transmitter RF Output P2 @ Standard Test Receiver (Max. RF IN: 45 dBm): -3 dBm
- Measured Signal generator Output P3 @ Standard Test Receiver (Max. RF IN: 45 dBm): -17 dBm

5.11.5.4.1. Test Configuration #1: Unmodulated

Time Interval	Transient Frequency	Transient Frequency Limit
t1 (5 mS) SWITCH ON CONDITION	-3.2 kHz	25 kHz
t2 (20 mS) SWITCH ON CONDITION	0.0 Hz	12.5 kHz
After t2 (5 mS) SWITCH ON CONDITION	0.0 Hz	FCC Limit = ± 750 Hz (0.0005% @ 150 MHz)
Before t3 (5 mS) SWITCH OFF CONDITION	0.0 Hz	FCC Limit = ± 750 Hz (0.0005% @ 150 MHz)
t3 (5 mS) SWITCH OFF CONDITION	0.0 Hz	25 kHz

5.11.5.4.2. Test Configuration #2: 4 Level of FM modulation with internal 9600 b/s random data

Time Interval	Transient Frequency	Transient Frequency Limit
t1 (5 mS) SWITCH ON CONDITION	+0.0 kHz	25 kHz
t2 (20 mS) SWITCH ON CONDITION	0.0 Hz	12.5 kHz
After t2 (5 mS) SWITCH ON CONDITION	0.0 Hz	FCC Limit = ± 750 Hz (0.0005% @ 150 MHz)
Before t3 (5 mS) SWITCH OFF CONDITION	0.0 Hz	FCC Limit = ± 750 Hz (0.0005% @ 150 MHz)
t3 (5 mS) SWITCH OFF CONDITION	0.0 Hz	25 kHz

5.11.6. Plots

Please refer to Plot # 29 through # 36 in Exhibit 8 for details of measurements

ULTRATECH GROUP OF LABS

3000 Bristol Circle, Oakville, Ontario, Canada L6H 6G4
 Tel. #: 905-829-1570, Fax. #: 905-829-8050, Email: yhk.ultratech@sympatico.ca, Website: <http://www.ultratech-labs.com>

File #: GLB-006FT
 Jan. 10, 2000

- Assessed by ITI (UK) Competent Body, NVLAP (USA) Accreditation Body & ACA/AUSTEL (Australia)
- Recognized/Listed by FCC (USA), Industry Canada (Canada)
- All test results contained in this engineering test report are traceable to National Institute of Standards and Technology (NIST)

EXHIBIT 6. MEASUREMENT UNCERTAINTY

The measurement uncertainties stated were calculated in accordance with the requirements of NIST Technical Note 1297 and NIS 81 (1994)

6.1. RADIATED EMISSION MEASUREMENT UNCERTAINTY

CONTRIBUTION (Radiated Emissions)	PROBABILITY DISTRIBUTION	UNCERTAINTY (\pm dB)	
		3 m	10 m
Antenna Factor Calibration	Normal (k=2)	± 1.0	± 1.0
Cable Loss Calibration	Normal (k=2)	± 0.3	± 0.5
EMI Receiver specification	Rectangular	± 1.5	± 1.5
Antenna Directivity	Rectangular	± 0.5	± 0.5
Antenna factor variation with height	Rectangular	± 2.0	± 0.5
Antenna phase center variation	Rectangular	0.0	± 0.2
Antenna factor frequency interpolation	Rectangular	± 0.25	± 0.25
Measurement distance variation	Rectangular	± 0.6	± 0.4
Site imperfections	Rectangular	± 2.0	± 2.0
Mismatch: Receiver VRC $\Gamma_1 = 0.2$ Antenna VRC $\Gamma_R = 0.67(\text{Bi}) 0.3 (\text{Lp})$ Uncertainty limits $20\text{Log}(1 \pm \Gamma_1 \Gamma_R)$	U-Shaped	+1.1 -1.25	± 0.5
System repeatability	Std. Deviation	± 0.5	± 0.5
Repeatability of EUT		-	-
Combined standard uncertainty	Normal	+2.19 / -2.21	+1.74 / -1.72
Expanded uncertainty U	Normal (k=2)	+4.38 / -4.42	+3.48 / -3.44

Calculation for maximum uncertainty when 3m biconical antenna including a factor of k=2 is used:

$$U = 2u_c(y) = 2x(+2.19) = +4.38 \text{ dB} \quad \text{And} \quad U = 2u_c(y) = 2x(-2.21) = -4.42 \text{ dB}$$

ULTRATECH GROUP OF LABS

3000 Bristol Circle, Oakville, Ontario, Canada L6H 6G4
 Tel. #: 905-829-1570, Fax. #: 905-829-8050, Email: yhk.ultratech@sympatico.ca, Website: <http://www.ultratech-labs.com>

File #: GLB-006FT
 Jan. 10, 2000

- Assessed by ITI (UK) Competent Body, NVLAP (USA) Accreditation Body & ACA/AUSTEL (Australia)
- Recognized/Listed by FCC (USA), Industry Canada (Canada)
- All test results contained in this engineering test report are traceable to National Institute of Standards and Technology (NIST)

EXHIBIT 7. MEASUREMENT METHODS

7.1. EFFECTIVE RADIATED POWER (ERP) MEASUREMENTS

- The following shall be applied to the combination(s) of the radio device and its intended antenna(e).
- If the RF level is user adjustable, all measurements shall be made with the highest power level available to the user for that combination.
- The following method of measurement shall apply to both conducted and radiated measurements.
- The radiated measurements are performed at the Ultratech Calibrated Open Field Test Site.
- The measurement shall be performed using normal operation of the equipment with modulation.

Test procedure shall be as follows:

Step 1: Duty Cycle measurements

- Using a spectrum analyzer with the frequency span set to 0 Hz and the sweep time set at a suitable value to capture the envelope peaks and the duty cycle of the transmitter output signal;
- The duty cycle of the transmitter, $x = \text{Tx on} / (\text{Tx on} + \text{Tx off})$ with $0 < x < 1$, is measure and recorded in the test report. For the purpose of testing, the equipment shall be operated with a duty cycle that is equal or more than 0.1.

Step 2: Calculation of Average EIRP. See Figure 1

- The average output power of the transmitter shall be determined using a wideband, calibrated RF power meter with the power sensor with an integration period that exceeds the repetition period of the transmitter by a factor 5 or more. The observed value shall be recorded as “A” (in dBm);
- The e.i.r.p. shall be calculated from the above measured power output “A”, the observed duty cycle x, and the applicable antenna assembly gain “G” in dBi, according to the formula:

$$\text{EIRP} = \text{A} + \text{G} + 10\log(1/x)$$

Figure 1.

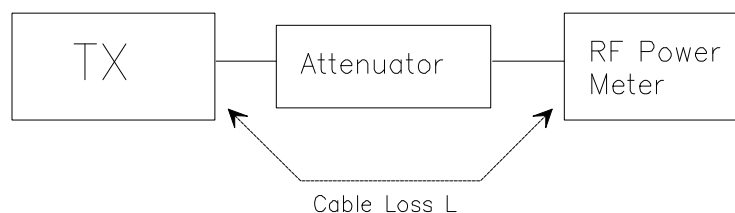

Step 3: Substitution Method. See Figure 2

- The measurements was performed in the absence of modulation (un-modulated)
- Test was performed at listed 3m open area test site (listed with FCC, IC, ITI, NVLAP, ACA & VCCI).
- The transmitter under test was placed at the specified height on a non-conducting turntable (80 cm height)
- The dipole test antenna was used and tuned to the transmitter carrier frequency.
- The spectrum analyzer was tuned to transmitter carrier frequency. The test antenna was lowered or raised from 1 to 4 meters until the maximum signal level was detected.
- The transmitter was rotated through 360° about a vertical axis until a higher maximum signal was received.
- The test antenna was lowered or raised again from 1 to 4 meters until a maximum was obtained. This level was recorded.

ULTRATECH GROUP OF LABS

3000 Bristol Circle, Oakville, Ontario, Canada L6H 6G4
Tel. #: 905-829-1570, Fax. #: 905-829-8050, Email: yhk.ultratech@sympatico.ca, Website: <http://www.ultratech-labs.com>

File #: GLB-006FT
Jan. 10, 2000

- Assessed by ITI (UK) Competent Body, NVLAP (USA) Accreditation Body & ACA/AUSTEL (Australia)
- Recognized/Listed by FCC (USA), Industry Canada (Canada)
- All test results contained in this engineering test report are traceable to National Institute of Standards and Technology (NIST)

- (h) The substitution dipole antenna and the signal generator replaced the transmitter and antenna under test in the same position, and the substitution dipole antenna was placed in vertical polarization. The test dipole antenna was lowered or raised as necessary to ensure that the maximum signal is still received.
- (i) The input signal to the substitution antenna was adjusted in level until an equal or a known related level to that detected from the transmitter in the test receiver. The maximum carrier radiated power is equal to the power supply by the generator.
- (j) The substitution antenna gain and cable loss were added to the signal generator level for the corrected ERP level.
- (k) Repeat steps (c) to (j) with the substitution antenna oriented in horizontal polarization.
- (l) Actual gain of the EUT's antenna is the difference of the measured ERP and measured RF power at the RF port. Correct the antenna gain if necessary.

Figure 2

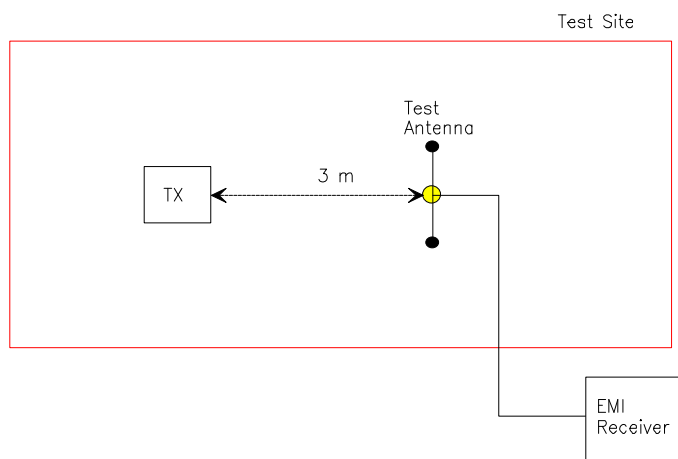
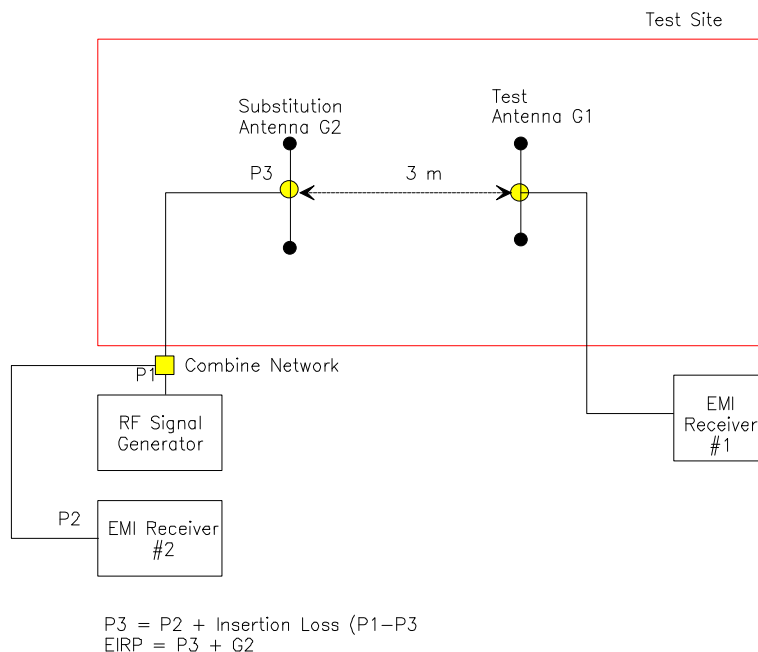

Figure 3



ULTRATECH GROUP OF LABS

3000 Bristol Circle, Oakville, Ontario, Canada L6H 6G4
 Tel. #: 905-829-1570, Fax. #: 905-829-8050, Email: vhk.ultratech@sympatico.ca, Website: <http://www.ultratech-labs.com>

File #: GLB-006FT
 Jan. 10, 2000

- Assessed by ITI (UK) Competent Body, NVLAP (USA) Accreditation Body & ACA/AUSTEL (Australia)
- Recognized/Listed by FCC (USA), Industry Canada (Canada)
- All test results contained in this engineering test report are traceable to National Institute of Standards and Technology (NIST)

7.2. FREQUENCY STABILITY

Refer to FCC @ 2.995.

- (a) The frequency stability shall be measured with variation of ambient temperature as follows: From -30 to +50 centigrade except that specified in subparagraph (2) & (3) of this paragraph.
- (b) Frequency measurements shall be made at extremes of the specified temperature range and at intervals of not more than 10 centigrade through the range. A period of time sufficient to stabilize all of the components of the oscillator circuit at each temperature level shall be allowed prior to frequency measurement. The short term transient effects on the frequency of the transmitter due to keying (except for broadcast transmitters) and any heating element cycling normally occurring at each ambient temperature level also shall be shown. Only the portion or portions of the transmitter containing the frequency determining and stability circuitry need be subjected to the temperature variation test.
- (d) The frequency stability supply shall be measured with variation of primary supply voltage as follows:
- (1) Vary primary supply voltage from 85 to 115 percent of the nominal value for other than hand carried battery equipment.
 - (2) For hand carried, battery powered equipment, reduce primary supply voltage to the battery operating end point which shall be specified by the manufacturer.
 - (3) The supply voltage shall be measured at the input to the cable normally provide with the equipment, or at the power supply terminals if cables are not normally provided. Effects on frequency of transmitter keying (except for broadcast transmitters) and any heating element cycling at the nominal supply voltage and at each extreme also shall be shown.
- (f) When deemed necessary, the Commission may require tests of frequency stability under conditions in addition to those specifically set out in paragraphs (a), (b), (c) and (d) of this section. (For example, measurements showing the effect of proximity to large metal objects, or of various types of antennas, may be required for portable equipment).

ULTRATECH GROUP OF LABS

3000 Bristol Circle, Oakville, Ontario, Canada L6H 6G4
Tel. #: 905-829-1570, Fax. #: 905-829-8050, Email: vhk.ultratech@sympatico.ca, Website: <http://www.ultratech-labs.com>

File #: GLB-006FT
Jan. 10, 2000

- Assessed by ITI (UK) Competent Body, NVLAP (USA) Accreditation Body & ACA/AUSTEL (Australia)
- Recognized/Listed by FCC (USA), Industry Canada (Canada)
- *All test results contained in this engineering test report are traceable to National Institute of Standards and Technology (NIST)*

7.3. EMISSION MASK

Voice or Digital Modulation Through a Voice Input Port @ 2.989(c)(i):- The transmitter was modulated by a 2.5 KHz tone signal at an input level 16 dB greater than that required to produce 50% modulation (e.g.: ± 2.5 KHz peak deviation at 1 KHz modulating frequency). The input level was established at the frequency of maximum response of the audio modulating circuit.

Digital Modulation Through a Data Input Port @ 2.989(h):- Transmitters employing digital modulation techniques - when modulated by an input signal such that its amplitude and symbol rate represent the maximum rated conditions under which the equipment will be operated. The signal shall be applied through any filter networks, pseudo-random generators or other devices required in normal service. Additionally, the Emission Masks shall be shown for operation with any devices used for modifying the spectrum when such devices are operational at the discretion of the user.

The following spectrum analyzer bandwidth shall be used for measurement of Emission Mask/Out-of-Band Emission Measurements:

- (1) For 25 kHz Channel Spacing: RBW = 300 Hz
- (2) For 12.5 kHz or 6.25 kHz Channel Spacings: RBW = 100 Hz

The all cases the Video Bandwidth shall be equal or greater than the measuring bandwidth.

7.4. SPURIOUS EMISSIONS (CONDUCTED)

With transmitter modulation characteristics described in Out-of-Band Emissions measurements @ 2.989, the transmitter spurious and harmonic emissions were scanned. The spurious and harmonic emissions were measured with the Spectrum Analyzer controls set as RBW = 30 kHz minimum , VBW \geq RBW and SWEEP TIME = AUTO). The transmitter was operated at a full rated power output, and modulated as follows:

FCC CFR 47, Para. 2.997 - Frequency spectrum to be investigated:- The spectrum was investigated from the lowest radio generated in the equipment up to at least the 10th harmonic of the carrier frequency or to the highest frequency practicable in the present state of the art of measuring techniques, whichever is lower. Particular attention should be paid to harmonics and subharmonics of the carrier frequency. Radiation at the frequencies of multiplier stages should be checked. The amplitude of spurious emissions which are attenuated more than 20 dB below the permissible value need not be reported.

FCC CFR 47, Para. 2.991 - Spurious Emissions at Antenna Terminal:- The radio frequency voltage or powers generated within the equipment and appearing on a spurious frequency shall be checked at the equipment output terminals when properly loaded with a suitable artificial antenna. Curves or equivalent data shall show the magnitude of the harmonic and other spurious emission that can be detected when the equipment is operated under the conditions specified in 2.989 as appropriate. The magnitude of spurious emissions which are attenuated more than 20 dB below the permissible value need not be specified.

ULTRATECH GROUP OF LABS

3000 Bristol Circle, Oakville, Ontario, Canada L6H 6G4
Tel. #: 905-829-1570, Fax. #: 905-829-8050, Email: yhk.ultratech@sympatico.ca, Website: <http://www.ultratech-labs.com>

File #: GLB-006FT
Jan. 10, 2000

- Assessed by ITI (UK) Competent Body, NVLAP (USA) Accreditation Body & ACA/AUSTEL (Australia)
- Recognized/Listed by FCC (USA), Industry Canada (Canada)
- All test results contained in this engineering test report are traceable to National Institute of Standards and Technology (NIST)

7.5. SPURIOUS EMISSIONS (RADIATED)

With transmitter modulation characteristics described in Out-of-Band Emissions measurements @ 2.989, the transmitter spurious and harmonic emissions were scanned. The spurious and harmonic emissions were measured with the Spectrum Analyzer controls set as RBW = 100 kHz minimum , VBW \geq RBW and SWEEP TIME = AUTO). The transmitter was operated at a full rated power output, and modulated as follows:

FCC CFR 47, Para. 2.997 - Frequency spectrum to be investigated:- The spectrum was investigated from the lowest radio generated in the equipment up to at least the 10th harmonic of the carrier frequency or to the highest frequency practicable in the present state of the art of measuring techniques, whichever is lower. Particular attention should be paid to harmonics and subharmonics of the carrier frequency. Radiation at the frequencies of multiplier stages should be checked. The amplitude of spurious emissions which are attenuated more than 20 dB below the permissible value need not be reported.

FCC CFR 47, Para. 2.993 - Field Strength Spurious Emissions

- (a) Measurements was made to detect spurious emissions radiated directly from the cabinet, control circuits, power leads, or intermediate circuit elements under normal conditions of installation and operation. Curves or equivalent data were supplied showing the magnitude of each harmonic and other spurious emission. For this test, single sideband, independent sideband, and controlled carrier transmitters shall be modulated under the conditions specified in paragraph 2.989(c) as appropriate. For equipment operating on frequencies below 1 GHz , an Open Field Test is normally required, with the measuring instrument antenna located in the far field at all test frequencies. In event it is either impractical or impossible to make open field measurements (e.g. a broadcast transmitter installed in a building) measurement will be accepted of the equipment as installed. Such measurements must be accompanied by a description of the site where the measurements were made showing the location of any possible source of reflections which might distort the field strength measurements. Information submitted shall include the relative radiated power of each spurious emission with the reference to the rated power output of the transmitter, assuming all emissions are radiated from half-wave dipole antennas.
- (b) Measurements specified in paragraph (a) of this section shall be made for the following equipment:
 - (1) Those in which the spurious emission are required to be 60 dB or more below the mean power of the transmitter.
 - (2) All equipment operating on frequencies higher than 25 MHz
 - (3) All equipment where the antenna is an integral part of, and attached directly to the transmitter.
 - (4) Other types of equipment as required, when deemed necessary by the Commission.

Maximizing RF Emission Level:

- (a) The measurements was performed with standard modulation
- (b) Test was performed at listed 3m open area test site (listed with FCC, IC, ITI, NVLAP, ACA & VCCI).
- (c) The transmitter under test was placed at the specified height on a non-conducting turntable (80 cm height)
- (d) The biconilog Antenna (20 MHz to 1 GHz) or Horn Antenna (1 GHz to 18 GHz) was used for measuring.
- (e) The spectrum analyzer was tuned to transmitter carrier frequency. The test antenna was lowered or raised from 1 to 4 meters until the maximum signal level was detected.
- (f) The transmitter was rotated through 360° about a vertical axis until a higher maximum signal was received.
- (g) The test antenna was lowered or raised again from 1 to 4 meters until a maximum was obtained. This level was recorded.
- (h) The recorded reading was corrected to the true field strength level by adding the antenna factor, cable loss and subtracting the pre-amplifier gain.

ULTRATECH GROUP OF LABS

3000 Bristol Circle, Oakville, Ontario, Canada L6H 6G4
Tel. #: 905-829-1570, Fax. #: 905-829-8050, Email: yhk.ultratech@sympatico.ca, Website: <http://www.ultratech-labs.com>

File #: GLB-006FT
Jan. 10, 2000

- Assessed by ITI (UK) Competent Body, NVLAP (USA) Accreditation Body & ACA/AUSTEL (Australia)
- Recognized/Listed by FCC (USA), Industry Canada (Canada)
- All test results contained in this engineering test report are traceable to National Institute of Standards and Technology (NIST)

- (i) The field strength level measured at 3m is converted to the power in dBm by subtracting a constant factor of 97.5 dB

METHOD OF CALCULATION FOR TRANSMITTED POWER (P) FROM THE MEASURED FIELD STRENGTH LEVEL (E):

According to IEC 801-3, the power density can be calculated as follows:

$$S = P / (4 \times \pi \times D^2) \quad \text{Where: } S: \text{ Power density in watts per square foot}$$

$$P: \text{ Transmitted power in watts}$$

$$\pi: 13.1415$$

$$D: \text{ Distance in meters}$$

The power density S (W/m²) and electric field E (V/m) is related by:

$$S = E^2 / (120 \times \pi)$$

Accordingly, the field intensity of isotropic radiator in free space can be expressed as follows:

$$E = (30 \times P)^{1/2} / D = 5.5 \times (P)^{1/2} / D$$

For Halfwave dipole antenna or other antennas correlated to dipole in direction of maximum radiation:

$$S = (1.64 \times P) / (4 \times \pi \times D^2)$$

$$E = (49.2 \times P)^{1/2} / D = 7.01 \times (P)^{1/2} / D$$

$$P = (E \times D / 7.01)^2$$

Calculation of transmitted power P (dBm) given a measured field intensity E (dBuV/m):

$$\begin{aligned} P(W) &= [E(V/m) \times D / 7.01]^2 \\ P(mW) &= P(W) \times 1000 \\ \Rightarrow P(dBm) &= 10 \log P(mW) \\ &= 20 \log E(V/m) + 20 \log(D) - 20 \log(7.01) + 10 \log 1000 \\ &= E(dBV/m) + 20 \log D + 13 \\ &= E(dBuV/m) - 120 + 20 \log(D) + 13 \\ &= E(dBuV/m) + 20 \log(D) - 107 \end{aligned}$$

The Transmitted Power @ D = 3 Meters

$$P(dBm) = E(dBuV/m) - 97.5$$

7.6. TRANSIENT FREQUENCY BEHAVIOR

1. Connect the transmitter under tests as shown in the above block diagram
2. Set the signal generator to the assigned frequency and modulate with a 1 kHz tone at ± 12.5 kHz deviation and its output level to be 50 dB below the transmitter rf output at the test receiver end.
3. Set the horizontal sweep rate on the storage scope to 10 milliseconds per division and adjust the display to continuously view the 1000 Hz tone from the Demodulator Output Port (DOP) of the Test Receiver. Adjust the vertical scale amplitude control of the scope to display the 1000 Hz at ± 4 divisions vertical Center at the display.
4. Adjust the scope so it will trigger on an increasing magnitude from the RF trigger signal of the transmitter under test when the transmitter was turned on. Set the controls to store the display.
5. The output at the DOP, due to the change in the ratio of the power between the signal generator input power and transmitter output power will, because of the capture effect of the test receiver, produce a change in display: For the first part of the sweep it will show the 1 kHz test signal. Then once the receiver's demodulator has been captured by the transmitter power, the display will show the frequency difference from the assigned frequency to the actual transmitter frequency versus time. The instant when the 1 kHz test signal is completely suppressed (including any capture time due to phasing) is considered to be t_{on} . The trace should be maintained within the allowed divisions during the period t_1 and t_2 .
6. During the time from the end of t_2 to the beginning of t_3 the frequency difference should not exceed the limits set by the FCC in Part 90.214 and the outlined in the Carrier Frequency Stability sections. The allowed limit is equal to FCC frequency tolerance limits specified in FCC 90.213.
7. Repeat the above steps when the transmitter was turned off for measuring t_3 .

ULTRATECH GROUP OF LABS

3000 Bristol Circle, Oakville, Ontario, Canada L6H 6G4
Tel. #: 905-829-1570, Fax. #: 905-829-8050, Email: vhk.ultratech@sympatico.ca, Website: <http://www.ultratech-labs.com>

File #: GLB-006FT
Jan. 10, 2000

- Assessed by ITI (UK) Competent Body, NVLAP (USA) Accreditation Body & ACA/AUSTEL (Australia)
- Recognized/Listed by FCC (USA), Industry Canada (Canada)
- *All test results contained in this engineering test report are traceable to National Institute of Standards and Technology (NIST)*

EXHIBIT 8. PLOTS OF MEASUREMENT DATA

ULTRATECH GROUP OF LABS

3000 Bristol Circle, Oakville, Ontario, Canada L6H 6G4
Tel. #: 905-829-1570, Fax. #: 905-829-8050, Email: yhk.ultratech@sympatico.ca, Website: <http://www.ultratech-labs.com>

File #: GLB-006FT
Jan. 10, 2000

- Assessed by ITI (UK) Competent Body, NVLAP (USA) Accreditation Body & ACA/AUSTEL (Australia)
- Recognized/Listed by FCC (USA), Industry Canada (Canada)
- *All test results contained in this engineering test report are traceable to National Institute of Standards and Technology (NIST)*

EXHIBIT 9. PHOTOGRAPHS OF TEST SETUP

ULTRATECH GROUP OF LABS

3000 Bristol Circle, Oakville, Ontario, Canada L6H 6G4
Tel. #: 905-829-1570, Fax. #: 905-829-8050, Email: vhk.ultratech@sympatico.ca, Website: <http://www.ultratech-labs.com>

File #: GLB-006FT
Jan. 10, 2000

- Assessed by ITI (UK) Competent Body, NVLAP (USA) Accreditation Body & ACA/AUSTEL (Australia)
- Recognized/Listed by FCC (USA), Industry Canada (Canada)
- *All test results contained in this engineering test report are traceable to National Institute of Standards and Technology (NIST)*

EXHIBIT 10. FCC FORM 731, APPLICANT'S LETTERS & STATEMENT

10.1. FCC FORM 731

10.2. APPLICANT'S AUTHORIZATION TO APPOINT ULTRATECH ENGINEERING LABS INC. TO ACT AS AN AGENT

10.3. LETTER REQUEST FOR FCC CONFIDENTIALITY FILING

10.4. RESTRICTION FOR USES OF THIS RADIO TRANSMITTER IN IN 406-406.1 MHZ BAND

10.5. RADIO FREQUENCY RADIATION EXPOSURE EVALUATION: MOBILE & UNLICENSED DEVICES@ FCC 2.1091

ULTRATECH GROUP OF LABS

3000 Bristol Circle, Oakville, Ontario, Canada L6H 6G4
Tel. #: 905-829-1570, Fax. #: 905-829-8050, Email: yhk.ultratech@sympatico.ca, Website: <http://www.ultratech-labs.com>

File #: GLB-006FT
Jan. 10, 2000

- Assessed by ITI (UK) Competent Body, NVLAP (USA) Accreditation Body & ACA/AUSTEL (Australia)
- Recognized/Listed by FCC (USA), Industry Canada (Canada)
- *All test results contained in this engineering test report are traceable to National Institute of Standards and Technology (NIST)*

EXHIBIT 11. FCC ID LABEL & SKETCH OF LABEL LOCATION

ULTRATECH GROUP OF LABS

3000 Bristol Circle, Oakville, Ontario, Canada L6H 6G4
Tel. #: 905-829-1570, Fax. #: 905-829-8050, Email: yhk.ultratech@sympatico.ca, Website: <http://www.ultratech-labs.com>

File #: GLB-006FT
Jan. 10, 2000

- Assessed by ITI (UK) Competent Body, NVLAP (USA) Accreditation Body & ACA/AUSTEL (Australia)
- Recognized/Listed by FCC (USA), Industry Canada (Canada)
- *All test results contained in this engineering test report are traceable to National Institute of Standards and Technology (NIST)*

EXHIBIT 12. “FCC INFORMATION TO USER”

ULTRATECH GROUP OF LABS

3000 Bristol Circle, Oakville, Ontario, Canada L6H 6G4
Tel. #: 905-829-1570, Fax. #: 905-829-8050, Email: yhk.ultratech@sympatico.ca, Website: <http://www.ultratech-labs.com>

File #: GLB-006FT
Jan. 10, 2000

- Assessed by ITI (UK) Competent Body, NVLAP (USA) Accreditation Body & ACA/AUSTEL (Australia)
- Recognized/Listed by FCC (USA), Industry Canada (Canada)
- *All test results contained in this engineering test report are traceable to National Institute of Standards and Technology (NIST)*

EXHIBIT 13. PHOTOGRAPHS OF EQUIPMENT UNDER TEST

ULTRATECH GROUP OF LABS

3000 Bristol Circle, Oakville, Ontario, Canada L6H 6G4
Tel. #: 905-829-1570, Fax. #: 905-829-8050, Email: yhk.ultratech@sympatico.ca, Website: <http://www.ultratech-labs.com>

File #: GLB-006FT
Jan. 10, 2000

- Assessed by ITI (UK) Competent Body, NVLAP (USA) Accreditation Body & ACA/AUSTEL (Australia)
- Recognized/Listed by FCC (USA), Industry Canada (Canada)
- *All test results contained in this engineering test report are traceable to National Institute of Standards and Technology (NIST)*

EXHIBIT 14. SYSTEM BLOCK DIAGRAM(S) & SCHEMATIC DIAGRAMS

ULTRATECH GROUP OF LABS

3000 Bristol Circle, Oakville, Ontario, Canada L6H 6G4
Tel. #: 905-829-1570, Fax. #: 905-829-8050, Email: yhk.ultratech@sympatico.ca, Website: <http://www.ultratech-labs.com>

File #: GLB-006FT
Jan. 10, 2000

- Assessed by ITI (UK) Competent Body, NVLAP (USA) Accreditation Body & ACA/AUSTEL (Australia)
- Recognized/Listed by FCC (USA), Industry Canada (Canada)
- *All test results contained in this engineering test report are traceable to National Institute of Standards and Technology (NIST)*

EXHIBIT 15. USER'S MANUAL

ULTRATECH GROUP OF LABS

3000 Bristol Circle, Oakville, Ontario, Canada L6H 6G4
Tel. #: 905-829-1570, Fax. #: 905-829-8050, Email: yhk.ultratech@sympatico.ca, Website: <http://www.ultratech-labs.com>

File #: GLB-006FT
Jan. 10, 2000

- Assessed by ITI (UK) Competent Body, NVLAP (USA) Accreditation Body & ACA/AUSTEL (Australia)
- Recognized/Listed by FCC (USA), Industry Canada (Canada)
- *All test results contained in this engineering test report are traceable to National Institute of Standards and Technology (NIST)*