



**HAC T-COIL SIGNAL TEST REPORT**

**FCC 47 CFR § 20.19  
ANSI C63.19-2019**

*For*  
**Smartphone**

**FCC ID: BCG-E8961A  
Model Name: A3526**

**Report Number: 15496273-S2V1  
Issue Date: 8/11/2025**

*Prepared for*  
**APPLE INC.  
1 APPLE PARK WAY  
CUPERTNO, CA 95014-2084**

*Prepared by*  
**UL VERIFICATION SERVICES INC.  
47173 BENICIA STREET  
FREMONT, CA 94538, U.S.A.  
TEL: (510) 319-4000  
FAX: (510) 661-0888**



CERT #0751.05

## Revision History

Rev.	Date	Revisions	Revised By
V1	8/11/2025	Initial Issue	--

## Table of Contents

<b>1. Attestation of Test Results .....</b>	<b>4</b>
<b>2. Test Methodology .....</b>	<b>5</b>
<b>3. Facilities and Accreditation .....</b>	<b>5</b>
<b>4. Test Equipment and Uncertainty .....</b>	<b>6</b>
4.1. Test Equipment .....	6
4.1.1. Base Station Simulator Software and Firmware .....	7
4.2. Measurement Uncertainty .....	8
<b>5. Test Procedures for all Technologies .....</b>	<b>9</b>
5.1. Test Procedure for T-Coil signal per ANSI C63.19-2019, §6 .....	9
5.2. Reference Input Levels per ANSI C63.19-2019, §6 .....	11
5.3. Over the Top (OTT) .....	12
<b>6. Calibrations &amp; Gain Measurements .....</b>	<b>14</b>
6.1. Calibration of AM1DVx Probe .....	14
6.1.1. Calibration Setup .....	14
6.1.2. Sensor Angle Alignment .....	14
6.1.3. System Response Calibration .....	14
6.2. AMMI Audio Output Calibration .....	14
6.3. Codec / System Delay Measurements .....	15
6.4. Compute Gain Settings .....	15
6.5. Over the Top (OTT) .....	16
<b>7. T-coil Measurement Criteria .....</b>	<b>17</b>
7.1. Frequency Response .....	17
7.2. Coupling Mode Requirements .....	18
7.3. Desired ABM Signal and Undesired ABM Field Requirements .....	19
7.3.1. Non-2G GSM Operating modes .....	19
7.3.2. 2G GSM Operating modes .....	19
<b>8. Device Under Test .....</b>	<b>20</b>
8.1. Air Interfaces and Operating Mode .....	20
<b>9. Investigations (Codec &amp; Air Interface) .....</b>	<b>22</b>
9.1. Codec Investigations .....	24
9.2. Air Interface Investigation .....	28
<b>10. HAC (T-coil) Test Results .....</b>	<b>30</b>
10.1. Worst Case T-Coil Test Plot(s) .....	31
<b>Appendix .....</b>	<b>33</b>
Appendix A: T-Coil Setup Photo .....	33
Appendix B: T-Coil Test Plots .....	33
Appendix C: T-Coil Probe Certificates .....	33

### 1. Attestation of Test Results



Applicant Name	APPLE, INC.
FCC ID	BCG-E8961A
Model Name	A3526
Applicable Standards	FCC 47 CFR § 20.19 ANSI C63.19-2019
Date Tested	8/4/2025 to 8/11/2025
Test Results	Pass

UL Verification Services Inc. tested the above equipment in accordance with the requirements set forth in the above standards. The test results show that the equipment tested can demonstrate compliance with the requirements as documented in this report.

This report contains data provided by the customer which can impact the validity of results. UL Verification Services Inc. is only responsible for the validity of results after the integration of the data provided by the customer.

The results documented in this report apply only to the tested sample, under the conditions and modes of operation as described herein. It is the manufacturer's responsibility to assure that additional production units of this model are manufactured with identical electrical and mechanical components. All samples tested were in good operating condition throughout the entire test program. Measurement Uncertainties are published for informational purposes only and were not considered unless noted otherwise.

This document may not be altered or revised in any way unless done so by UL Verification Services Inc. and all revisions are noted in the revisions section. Any alteration of this document not carried out by UL Verification Services Inc. will constitute fraud and shall nullify the document. This report must not be used by the client to claim product certification, approval, or endorsement by A2LA, NIST, or any agency of the U.S. Government, or any agency of the U.S. government.

Approved & Released By:  	Prepared By:  
Devin Chang Senior Laboratory Engineer UL Verification Services Inc.	Miguel Llamas Laboratory Supervisor UL Verification Services Inc.

## 2. Test Methodology

The tests documented in this report were performed in accordance with ANSI C63.19-2019 Methods of Measurement of Compatibility Between Wireless Communications Devices and Hearing Aids and FCC published procedure:

KDB 285076 D01 HAC Guidance v06r04  
KDB 285076 D02 T-Coil testing for CMRS IP v04  
KDB 285076 D03 HAC FAQ v01r07

In addition to the above, the following guidance was used:

TCB workshop updates:

- TCB Workshop October 2022; Publication Update & Administrative Notes (Publication Update: 285076 D01 & D04)
- TCB Workshop October 2022; Federal Communications Commission Hearing Aid Compatibility Updates
- TCB Workshop April 2023; Publication Update & Administrative Notes (Publications Since Oct Workshop: 285076 HAC Update)
- TCB Workshop October 2023; Publication Update & Administrative Notes (Publication Update: 285076 09/29/2023: HAC Guidance blanket)
- TCB Workshop April 2024; HAC Updates (Handset Configuration)

## 3. Facilities and Accreditation

The test sites and measurement facilities used to collect data are located at

47266 Benicia Street
----------------------

SAR Lab 19
------------

UL Verification Services Inc. is accredited by A2LA, Certificate Number 0751.05

## 4. Test Equipment and Uncertainty

### 4.1. Test Equipment

The measuring equipment used to perform the tests documented in this report has been calibrated in accordance with the manufacturers' recommendations and is traceable to recognized national standards.

#### Lab Equipment

Name of Equipment	Manufacturer	Type/Model	Serial No.	Cal. Due Date
Magnetic Field Probe	SPEAG	AM1DV3	3165	3/4/2026
Data Acquisition Electronics	SPEAG	DAE4ip	1881	2/17/2026
AMMI	SPEAG	SE UMS 010 BB	2010	N/A
DAC	Sound Devices	USBPre 2	HB1118191000	N/A
DAC	Yellowtech	YT4211	248643	N/A
Switch	TP-Link	TL-SG1016D	2165473001109	N/A
Support Device	Apple	Macbook	HRP119301	N/A
Base Station Simulator	R&S	CMW 500	170269-HX	2/10/2026
Base Station Simulator	R&S	CMX 500	101639-EE	2/14/2026

#### 4.1.1. Base Station Simulator Software and Firmware

The following software/firmware was used to simulate the VoLTE, VoNR and VoWiFi server for CMRS testing using R&S CMW500 and CMX500 base station simulators:

Technology	Firmware	License Key	Software Name
VoLTE	V3.8.10 for LTE	KS500	LTE FDD R8 SIG BASIC
		KS550	LTE TDD R8 SIG BASIC
	V3.8.10 for Audio	KA100	IP APPL ENABLING IPv4
		KA150	IP APPL ENABLING IPv6
		KAA20	IP APPL IMS BASIC
		KM050	DATA APPL MEAS
		KS104	EVS SPEECH CODEC
VoNR 5G NR (FR1)	V8.20.0.112 for 5G NR	CMX-KS600B	NR SIG BASIC FSET1
		CMX-KS600M	NR SIG MEDIUM FSET1
		CMX-KS601B	NR SIG BASIC FSET2
		CMX-KS601M	NR SIG MEDIUM FSET2
		CMX-KS610B	NR SIG ETX. BASIC FSET3
		CMX-KS610M	NR SIG ETX. MEDIUM FSET3
		CMX-KS611B	NR SIG ETX. BASIC FSET4
	V8.20.0.112 for Audio	CMX-KA100	IP APPL FSET1
		CMX-KA110	IP APPL FSET2
		CMX-KA180	APPL AUDIO
		CMX-KA181	APPL AUDIO POLQA
		VoWiFi	V3.8.20 for WLAN
KS651	WLAN N SIG BASIC		
KS656	WLAN IEEE 802.11ac		
KS657	WLAN IEEE 802.11ax		
V3.8.10 for Audio	KA100		IP APPL ENABLING IPv4
	KA150		IP APPL ENABLING IPv6
	KAA20		IP APPL IMS BASIC
	KM050		DATA APPL MEAS
	KS104		EVS SPEECH CODEC

## 4.2. Measurement Uncertainty

Uncertainty of Audio Band Magnetic Measurements							
Error Description	Uncertainty Values ( $\pm\%$ )	Probe Dist.	Div.	(c <sub>i</sub> ) ABMd	c <sub>i</sub> ABMu	Std. Uncertainty	
						ABMd ( $\pm\%$ )	ABMu ( $\pm\%$ )
<b>Probe Sensitivity</b>							
Reference Level	3.0	N	1	1	1	3.0	3.0
AMCC Geometry	0.4	R	$\sqrt{3}$	1	1	0.2	0.2
AMCC Current	1.0	R	$\sqrt{3}$	1	1	0.6	0.6
Probe Positioning during Calibration	0.1	R	$\sqrt{3}$	1	1	0.1	0.1
Noise Contribution	0.7	R	$\sqrt{3}$	0.0143	1	0.0	0.4
Frequency Slope	5.9	R	$\sqrt{3}$	0.1	1.0	0.3	3.5
<b>Probe System</b>							
Repeatability / Drift	1.0	R	$\sqrt{3}$	1	1	0.6	0.6
Linearity / Dynamic Range	0.6	R	$\sqrt{3}$	1	1	0.4	0.4
Acoustic Noise	1.0	R	$\sqrt{3}$	0.1	1	0.1	0.6
Probe Angle	1.0	R	$\sqrt{3}$	1	1	0.6	0.6
Spectral Processing	0.9	R	$\sqrt{3}$	1	1	0.5	0.5
Integration Time	0.6	N	1	1	5	0.6	3.0
Field Disturbation	0.2	R	$\sqrt{3}$	1	1	0.1	0.1
<b>Test Signal</b>							
Reference Signal Spectral Response	0.6	R	$\sqrt{3}$	0	1	0.0	0.4
<b>Positioning</b>							
Probe Positioning	1.9	R	$\sqrt{3}$	1	1	1.1	1.1
Phantom Thickness	0.9	R	$\sqrt{3}$	1	1	0.5	0.5
DUT Positioning	1.9	R	$\sqrt{3}$	1	1	1.1	1.1
<b>External Contributions</b>							
RF Interference	0.0	R	$\sqrt{3}$	1	0.3	0.0	0.0
Test Signal Variation	2.0	R	$\sqrt{3}$	1	1	1.2	1.2
<b>Combined Uncertainty</b>							
Combined Std. Uncertainty (ABM field)						3.9	6.0
<b>Expanded Std. Uncertainty (%)</b>						<b>7.8</b>	<b>11.9</b>
Notes:							
1. N - Nomal							
2. R - Rectangular							
3. Div. - Divisor used to obtain standard uncertainty							
4. ABMd - Desired ABM Signal							
5. ABMu - Undesired ABM Field							



## 5. Test Procedures for all Technologies

### 5.1. Test Procedure for T-Coil signal per ANSI C63.19-2019, §6

This subclause describes the procedures used to measure the ABM (T-Coil) performance of the WD. Measurements shall be performed over a measurement area 50 mm square, in the measurement plane, as specified in Annex A.3. The measurement area shall be scanned with a uniform measurement point spacing of  $2.0 \text{ mm} \pm 0.5 \text{ mm}$  in each X-Y axis of the plane, yielding 676 measurement points with approximately even spacing throughout the area.

Optionally, measurement point spacing may be increased to 4 mm, with interpolation employed to yield the required 676 equivalent measurement points distributed uniformly over the 50 mm square measurement area. Interpolated points shall be derived from the average of the linear representations of the field strengths of the nearest two or four equidistant measured points. The area of measurement is increased to a 52 mm square so that edge rows and columns of the required 50 mm square can be either measured or interpolated, with none extrapolated.

In addition to measuring the desired ABM signal levels, the weighted magnitude of the unintended signal shall also be determined. Weighting of the unintended and undesired ABM field shall be by the spectral and temporal weighting described in Annex D.4 through D.6.

To ensure that the required signal quality is measured, the measurement of the intended signal and the measurement of the unintended signal shall be made at the same locations. Measurements shall not include undesired influence from the WD's RF field; therefore, use of a coaxial connection to a base station simulator or non-radiating load might be necessary. However, even then with a coaxial connection to a base station simulator or non-radiating load there could still be RF leakage from the WD, which could interfere with the desired measurement. Pre-measurement checks should be made to avoid this possibility. All measurements shall be done with the WD operating on battery power with an appropriate normal speech audio signal input level given in Table 6.1. If the device display can be turned off during a phone call, then that may be done during the measurement as well. If tested with the display in the off state this shall be documented in the test report.

Measurements shall be performed with the probe coil oriented in the transverse direction, as illustrated in Annex A.3, that is, aligned in the plane of the measurement area and perpendicular to the long dimension of the WD. A multi-stage sequence consists of first measuring the field strength of the desired T-Coil signal (desired ABM signal) that is useful to a hearing aid T-Coil at each specified measurement point. The undesired magnetic component (undesired ABM field) is then measured in the same transverse orientation at each of the same measurement points. At a single location only, taken at or near the highest desired ABM signal reading, the desired ABM signal frequency response shall be determined in a third measurement stage. The flowchart in Figure 6.3 illustrates this three-stage process.

To minimize the need to test every WD operating mode to the telecoil requirements of Clause 6, it is permissible to exclude some subset of supported configurations. For a given WD, every mode that supports voice communication shall be considered for telecoil testing. However, if it can be demonstrated that a certain configuration will not be the worst-case telecoil configuration, such configurations may be excluded from the full telecoil scans of 6.4.<sup>1</sup> For example, operating modes may be pre-screened by scanning for both desired ABM signal and undesired ABM field at a lower measurement point density than the final scans, thus saving considerable testing time by eliminating configurations that are excellent performers from more detailed testing for worst-case. In any case, the specific methods and criteria used to determine which configurations are excluded for a WD shall be explicitly stated and justified in the test report. To be considered for exclusion from telecoil testing, operating modes shall also be shown to pass the frequency response requirements of 6.6.3.

Many factors could affect telecoil test results. RF power level and amplitude modulation characteristics as well as the specific current paths within the WD associated with the RF output stage(s), the display, and processing circuitry could affect the undesired ABM field. Audio codec implementation and acoustic receiver characteristics could also affect the desired ABM signal). Therefore, any justifications for exclusions should be thorough documented. If an operating mode is under user control and instructions on how to place the WD in a less interfering condition is in the user instructions, those instructions may be followed in configuring the device for testing.

The following steps summarize the basic test flow for determining desired ABM signal and undesired ABM field. These steps assume that a sine wave or narrowband 1/3 octave signal can be used for the measurement of desired

<sup>1</sup> The allowance to not test all modes does not remove the requirement that all modes meet the requirements of this standard if a claim of compliance is to be made. What is allowed is a reduction of testing, where there is a good basis for believing that testing that is performed demonstrates the compliance of all possible operating modes.

ABM signal level. An alternative procedure, yielding equivalent results, using a broadband excitation is described in 6.5.

- a) A validation of the test setup and instrumentation shall be performed. This may be done using a TMFS or Helmholtz Coil. Measure the emissions and confirm that they are within tolerance of the expected values.
- b) Confirm that equipment that requires calibration has been calibrated, and that the noise level meets the requirements given in 6.3.2.
- c) Position the WD in the test setup and connect the WD RF connector to a base station simulator or a non-radiating load (if necessary to control RF interference in the measurement equipment) as shown in Figure 6.1 or Figure 6.2.
- d) The drive level to the WD is set such that the reference input level specified in Table 6.1 is input to the base station simulator (or manufacturer's test mode equivalent) in the 1 kHz, 1/3 octave band. This drive level shall be used for the T-Coil signal test (desired ABM signal) at  $f = 1$  kHz. Either a sine wave at 1025 Hz, or a voice-like signal, band-limited to the 1 kHz 1/3 octave, as specified in 6.4.3, shall be used for the reference audio signal. If interference is found at 1025 Hz an alternative nearby reference audio signal frequency may be used.<sup>2</sup> The same drive level will be used for the desired ABM signal frequency response measurements at each 1/3 octave band center frequency. The WD volume control may be set at any level up to maximum, provided that a signal at any frequency at maximum modulation would not result in clipping or signal overload.
- e) At each measurement location over the measurement area and in the transverse orientation, measure and record the desired 1 kHz T-Coil magnetic signal (desired ABM signal) as described in Step c).
- f) At or near a location representing a maximum in the just-measured desired ABM signal, measure and record the desired T-Coil magnetic signals (desired ABM signal at  $f_i$ ) as described in 6.4.5.2 in each individual ISO 266:1975 R10 standard 1/3 octave band. The desired audio band input frequency ( $f_i$ ) shall be centered in each 1/3 octave band maintaining the same drive level as determined in Step c), and the reading taken for that band.<sup>3</sup> Equivalent methods of determining the frequency response may also be employed, such as fast Fourier transform (FFT) analysis using noise excitation or input-output comparison using simulated speech. The full-band integrated or half-band integrated probe output, as described in D.9, may be used, as long as the appropriate calibration curve is applied to the measured result, so as to yield an accurate measurement of the field magnitude. (The resulting measurement shall be an accurate measurement in dB(A/m).) Compare the frequency response found to the requirements of 6.6.3.
- g) At the same locations measured in Step d), measure and record the undesired broadband audio magnetic signal (undesired ABM field) with no audio signal applied (or digital zero applied, if appropriate) using the specified spectral weighting, the half-band integrator followed by the temporal weighting.
- h) Calculate and record the location and number of the measurement points that satisfy both the minimum desired ABM signal level and the maximum undesired ABM field level specified in 6.6.2. Compare this to the requirements in 6.6.4 and record the result.
- i) Calculate and record the location and number of the measurement points that satisfy the maximum undesired ABM field level and distribution requirements specified in 6.6.4.

<sup>2</sup> The 1025 Hz frequency was selected rather than 1 kHz because a 1 kHz reference frequency could interfere with emission harmonics or test equipment fundamental frequencies.

<sup>3</sup> See 6.4.5.2 and 6.4.5.4 for details.

Test Setup Diagram

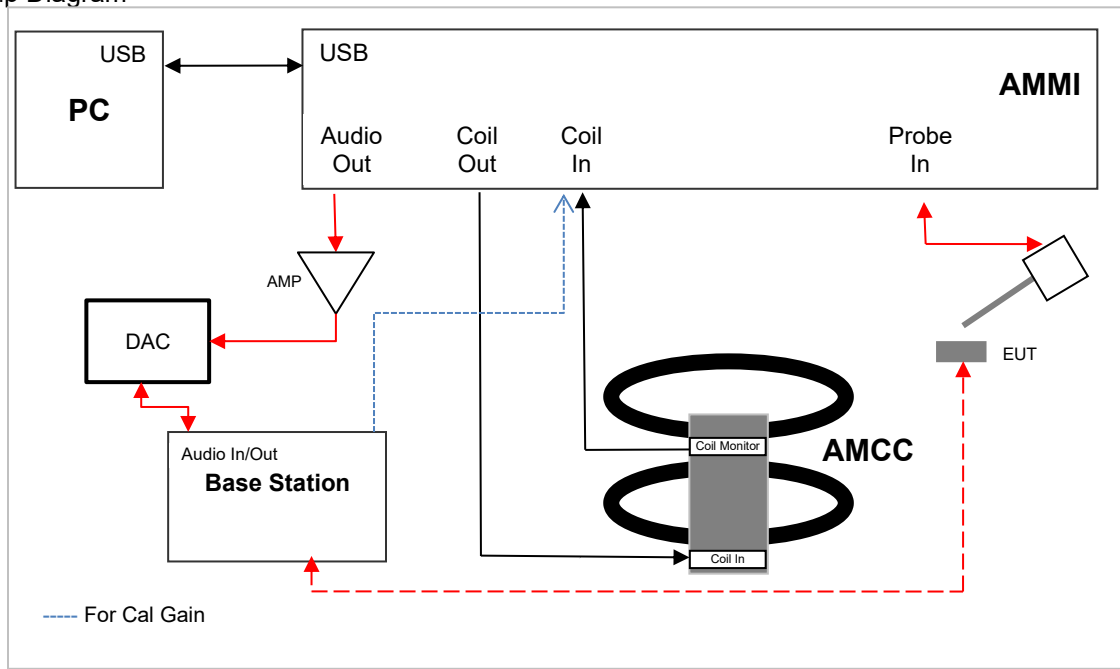

**Note(s):**  
For Audio OUT, an amplifier was added to amplify signal to meet DAC specifications.

**5.2. Reference Input Levels per ANSI C63.19-2019, §6**

The following reference input levels (Figure 6.1) that correlate to a normal speech input level shall be used for the standard transmission protocols.

Table 6.1 - Normal speech input levels

Standard	Protocol	Input (dBm0)
TIA-2000	CDMA	-18
TIA/EIA-136	TDMA (50 Hz)	-18
J-STD-007	GSM (217 Hz)	-16
T1/T1P1/3GPP (See Note 1)	UMTS (WCDMA)	-16
iDEN®	TDMA (22 Hz and 11 Hz)	-18
VoIP <sup>a</sup> (See Note 2)	Voice over Internet Protocol	-16

NOTE 1 - For UMTS (Universal Mobile Telecommunications System), refer to 3GPP TS26.131 and TS26.132 (<http://www.3gpp.org>).  
NOTE 2 - VoIP is used in this table as a general term specifying a group of voice services that use -16 dBm0 as their normal acoustic level. The group includes a variety of voice services, including Voice-over-LTE (VoLTE), Voice-over-IP-multimedia-subsystem (VoIMS), Voice-over-Wi-Fi (VoWiFi) and similar services. For 3G, LTE, and WLAN terminals used for Commercial Mobile Radio Service (CMRS) based telephony, refer to 3GPP TS26.131 and TS26.132.

<sup>a</sup> The manufacturer shall establish that -16 dBm0 is the normal acoustic level in order to place it in this category.

For protocols not listed in Table 6.1, use the normal speech input level per the relevant specifications for that air interface.<sup>4</sup>

<sup>4</sup> The intent of this subclause is to provide a nominal level speech input independent of air interface and measure the magnetic response in a normal use condition without requiring an acoustic reference. The nominal level speech signals in 6.4.3.2 will result in acoustic speech levels that are mutually consistent and also span a range including 94 dB SPL, as shown in the examples below. This is intended to allow the operator to set WD adjustable volume controls as needed to produce a sufficient desired magnetic level (desired ABM signal) based on intended usage. When measuring with the specified nominal speech input level of -16 dBm0 for GSM, a GSM phone shall not exceed a receive loudness rating (RLR) of -13 dB at maximum volume setting. However, at a nominal volume control setting with the same -16 dBm0 input, a GSM phone shall have an RLR of at least 2 dB ± 3 dB. An RLR of 2 dB ± 3 dB corresponds to a sound pressure level of 84 dB ± 3 dB SPL, assuming an earpiece frequency response that is flat over the frequency bands specified as per ITU-T Recommendation P.79. An RLR of -13 dB corresponds to a sound pressure level of 99 dB SPL, assuming an earpiece frequency response that is flat over the frequency bands specified as per ITU-T Recommendation P.79. When measuring with the specified nominal speech input level of -18 dBm0 for CDMA, a CDMA phone with volume control set to the midpoint should provide an RLR of 2 dB ± 5 dB. The CTIA (Rev. 3.21, 2003) CDMA test plan (V1.2) does not specifically place an upper limit on RLR. References: ITU-T Recommendation P.79. Calculation of loudness ratings for telephone handsets. Cellular Telecommunications Industry Association Performance Evaluation Standard for 800 MHz AMPS and Cellular/PCS CDMA Dual Mode Wireless Subscriber Stations.

### 5.3. Over the Top (OTT)

This device supports VoIP via a preinstalled application that uses the FaceTime service, using ACC-ELD as its only codec (refer to §8.1 for air interface details and §9.2.2 for codec bit rates). VoIP capabilities require HAC assessment when voice calls are supported over the cellular data connection via pre-installed VoIP applications.

The equipment is set up as shown below with a support device used to originate the call using the IP transport. The support device<sup>5</sup> connects to the cloud-based FaceTime service via a Wi-Fi access point and router, or an RJ45 Ethernet connection. The DUT connects to the VoIP service via a cellular/unlicensed air interface to the call box and an Ethernet connection from call box to Internet. The various codec bit rate and air interface configurations are evaluated to determine the worst-case configuration (refer to §9.2).

Test Setup configuration for OTT calls

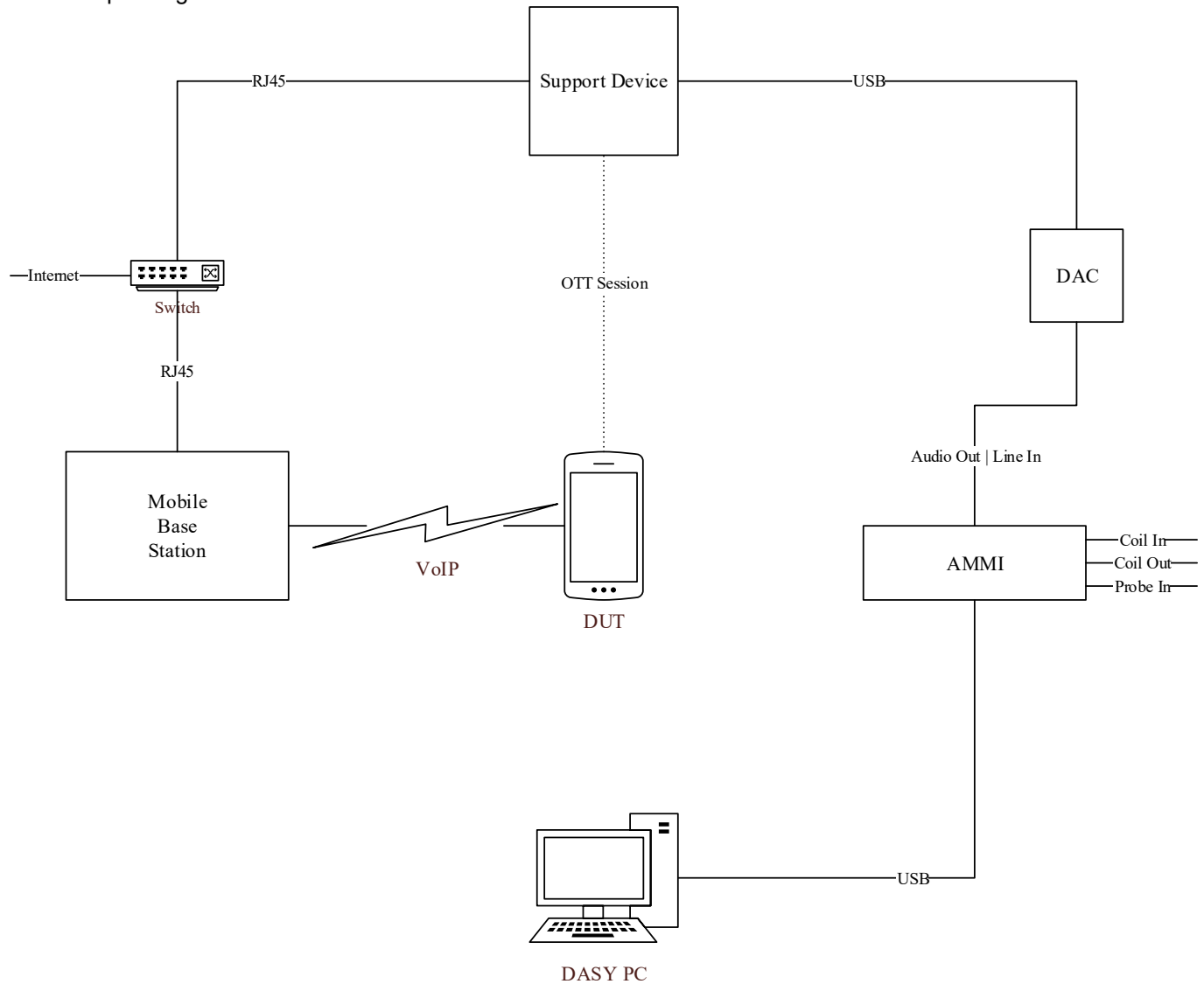

For the OTT call, the calibrated audio card within the CMW500 cannot be used so the AMMI is connected to an external Digital-Analog Converter (DAC) and the DAC is connected to the Support Device via USB. The test signal is sent from the DASY PC to the AMMI, from the AMMI to the DAC, from the DAC to the Support Device, and, via the VoIP call, to the DUT.

<sup>5</sup> The support device is a Apple Macbook.

As this test set up uses an external DAC between the AMMI's audio output and support device, the appropriate gain factor for the OTT call needs to be determined. This is done by connecting the DAC between the AMMI Audio output and Coil input as shown below.

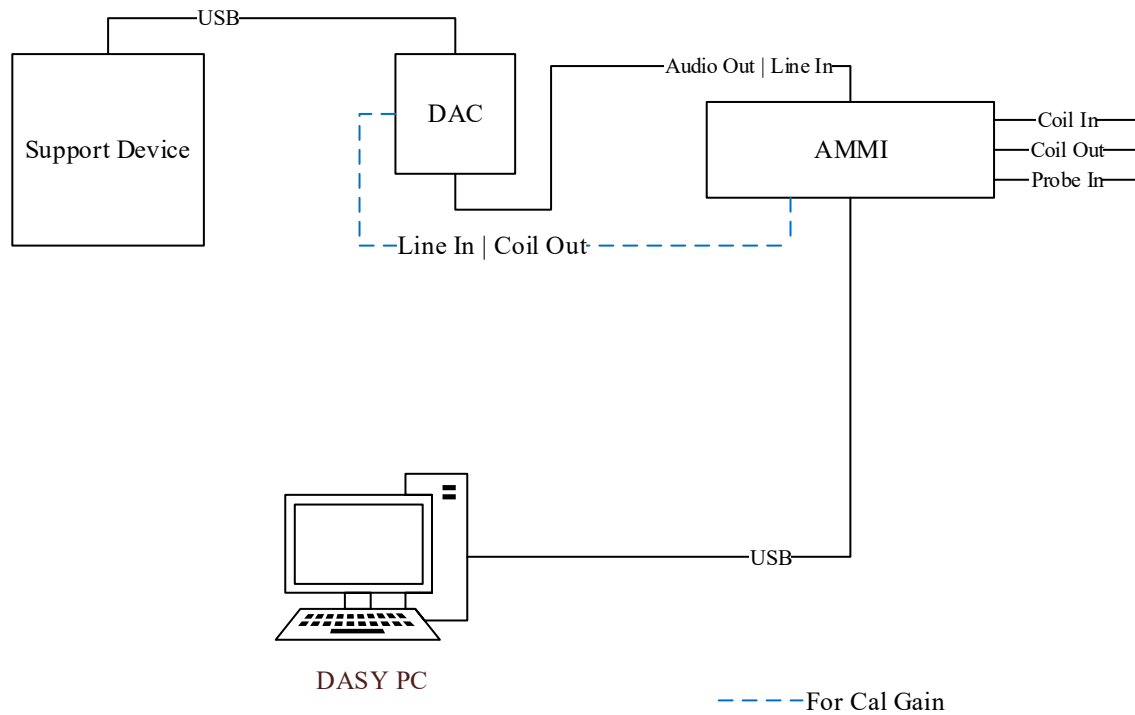

Once the proper cable connections are established, the procedures outlined in §6 are followed to calculate the appropriate Gain and codec / system delays for OTT measurements. Please refer to §6.5 for computed OTT gain settings and the test data tables in §9 & 10 for all Codec / system delay measurements performed during OTT testing.

## 6. Calibrations & Gain Measurements

Calibrations and Gain measurements are performed using guidance from SPEAG's *DASY6/8 Module HAC System Handbook §7.3*.

### 6.1. Calibration of AM1DVx Probe

For correct measurement of the audio-band magnetic field, the AM1DVx probe must first be calibrated. The calibration is performed in the Helmholtz Audio Magnetic Calibration Coil (AMCC).

#### 6.1.1. Calibration Setup

During the calibration procedure, the system is set as described below:

- the AMMI is powered on and connected to the DASY6/8 PC via USB.
- the AMMI COIL OUT port is connected to the AMCC COIL IN.
- the AMMI COIL IN port is connected to the AMCC COIL MONITOR.
- the AM1DVx probe is mounted on the robot.

#### 6.1.2. Sensor Angle Alignment

The sensor angle relative to the robot arm depends on several factors: probe connector angle, Data Acquisition Electronics (DAE) connector angle, use of a Quick Adaptor Change System (QACS). In DASY6/8, the sensor angle is assessed automatically during the alignment phase.

The alignment procedure consists of rotating the probe in the AMCC for an angle within the  $[0^\circ - 360^\circ]$  in  $10^\circ$  steps. The sensor angle is defined as the angle giving the maximum H-field response for the sensor. The angle corresponds to the sensor in the axial direction (same orientation as the AMCC field).

**Note:** The calibration must be repeated after any change in the measurement instrumentation, especially when the probe / DAE has been remounted on the robot.

#### 6.1.3. System Response Calibration

The sensitivity and frequency response of the AM1DVx probe is calibrated over the  $[50\text{Hz} - 10\text{kHz}]$  frequency range using a multi-sine signal. The sines are at the center frequency of each 1/3 octave band.

The measurement is performed in the AMCC with the probe sensor in axial orientation. The Coil In channel of the Audio Magnetic Measurement Instrument (AMMI) measures the voltage over the AMCC internal shunt, which is proportional to the magnetic field in the AMMI. In parallel, the Probe In channel measures the amplified signal picked up by the probe coil. The sensitivity of the probe in  $\text{V}/(\text{A}/\text{m})$  is defined as the voltage ratio at 1 kHz. The frequency response in dB is defined as the ratio between the voltages in each 1/3 octave band normalized to the 1 kHz ratio.

The obtained sensitivity is compared to the one from the probe configuration file for verification purposes. A warning is issued if the deviation exceeds 2 %.

### 6.2. AMMI Audio Output Calibration

The audio output calibration of the AMMI is performed as described below:

- Connect Audio Out to Coil In on the AMMI and click on Calibrate.
- Click on the Calibrate button.
- Once calibration is complete, re-establish the cabling illustrated in Test Setup Diagram §5.1.

### 6.3. Codec / System Delay Measurements

Codec / system delay measurements are calculated using the guidance from SPEAG's *DASY6/8 Module HAC System Handbook* §7.3.2.4:

- A time delay might occur in the audio signal path (latency of the codec, Windows settings ...). For accurate measurements, the system must take into account this delay, and shift in time the probe readings accordingly.
- Module HAC features automated measurement of the delay. The assessed delay will then be used for the subsequent desired ABM signal level and undesired ABM field level measurements.
- The delay is measured by pressing the Assess Delay button under the Scan Control section of the Measurement tab. The system must be ready to measure, and the DUT must be transmitting in the desired test mode.
- A scan with reduced resolution will be performed and the delay will be assessed at the measured maximum.
- This measurement must be repeated after every change in the hardware setup, or when a different DUT / Codec is used.

Please refer to test data tables in §9 & 10 for all Codec / system delay measurements performed during testing.

### 6.4. Compute Gain Settings

Gain settings are computed using the following procedure:

- Define the Scan Type as Signal in the Scan Type section.
- Specify the Input Level and Codec Delay in the Base Station Simulator Settings.
  - Input level refers to full scale input level equivalent to 3.14 dBm0.
    - Input level of 1V is used for R&S CMW500 Base Station Simulator.
    - Input level of 1.23V is used for R&S CMX500
  - The codec delay can be measured automatically using the procedure described above in §6.3 above.
- Enter the desired speech level in dBm0. Refer to §5.2 for applicable Reference Input Levels.
- Specify the audio file and the measurement duration to be used for the area and frequency response scans.
  - Use Audio file 48k\_voice\_1kHz\_1s.wav for ABMd and ABMu measurements.
  - Use Audio file 48k\_voice\_300-3000\_2s.wav for Frequency Response measurements.
- Click on Compute Gain Settings. The properties of the audio file, such as the bandwidth compensation factor (BWC), peak value, etc. will be automatically computed. In addition, the audio file scaling (also called gain) will be calculated. A popup is displayed in case the resulting gain exceeds the AMMI dynamic range.

Computed Gain settings for each supported technology is illustrated in the table below:

#### SAR 19

Computed Gain Settings						
Technology	Signal Type	Speech Level (dBm0)	Peak to Full Scale (dB)	Peak to RMS Scale (dB)	BWC (dB)	Scaling (Gain) (dB)
GSM	Voice 1 kHz	-16.0	-0.37	15.74	0.07	-12.48
	Voice 300-3kHz	-16.0	0	21.57	10.81	-6.65
W-CDMA	Voice 1 kHz	-16.0	-0.37	15.74	0.07	-12.48
	Voice 300-3kHz	-16.0	0	21.57	10.81	-6.65
VoLTE	Voice 1 kHz	-16.0	-0.37	15.74	0.07	-12.48
	Voice 300-3kHz	-16.0	0	21.57	10.81	-6.64
VoNR	Voice 1 kHz	-16.0				
	Voice 300-3kHz	-16.0				
VoWiFi	Voice 1 kHz	-16.0	-0.37	15.74	0.07	-12.47
	Voice 300-3kHz	-16.0	0	21.57	10.81	-6.64

## 6.5. Over the Top (OTT)

For GSM, W-CDMA, LTE, 5G NR and Wi-Fi, the procedures outlined in §6.4 above were followed to compute the appropriate Gain settings for OTT measurement using Input level of 1.228292V is used for USBPre 2

Computed Gain settings for each supported technology is illustrated in the table below:

### SAR 19

Computed Gain Settings						
Technology	Signal Type	Speech Level (dBm0)	Peak to Full Scale (dB)	Peak to RMS Scale (dB)	BWC (dB)	Scaling (Gain) (dB)
GSM	Voice 1 kHz	-16.0	-0.37	15.74	0.07	-10.69
	Voice 300-3kHz	-16.0	0	21.57	10.81	-4.85
W-CDMA	Voice 1 kHz	-16.0	-0.37	15.74	0.07	-10.69
	Voice 300-3kHz	-16.0	0	21.57	10.81	-4.86
LTE	Voice 1 kHz	-16.0	-0.37	15.74	0.07	-10.69
	Voice 300-3kHz	-16.0	0	21.57	10.81	-4.86
5G NR	Voice 1 kHz	-16.0	-0.37	15.74	0.07	-10.69
	Voice 300-3kHz	-16.0	0	21.57	10.81	-4.85
WLAN	Voice 1 kHz	-16.0	-0.37	15.74	0.07	-10.68
	Voice 300-3kHz	-16.0	0	21.57	10.81	-4.85



## 7. T-coil Measurement Criteria

### 7.1. Frequency Response

The frequency response of the magnetic field, measured in 1/3 octave bands, shall follow the response curve specified in this subclause, over the frequency range 300 Hz to 3 kHz.

Figure 6.4 and Figure 6.5 provide the boundaries for the specified frequency. These response curves are for true field strength measurements of the T-Coil signal. Thus the 6 dB/octave probe response has been corrected from the raw readings.

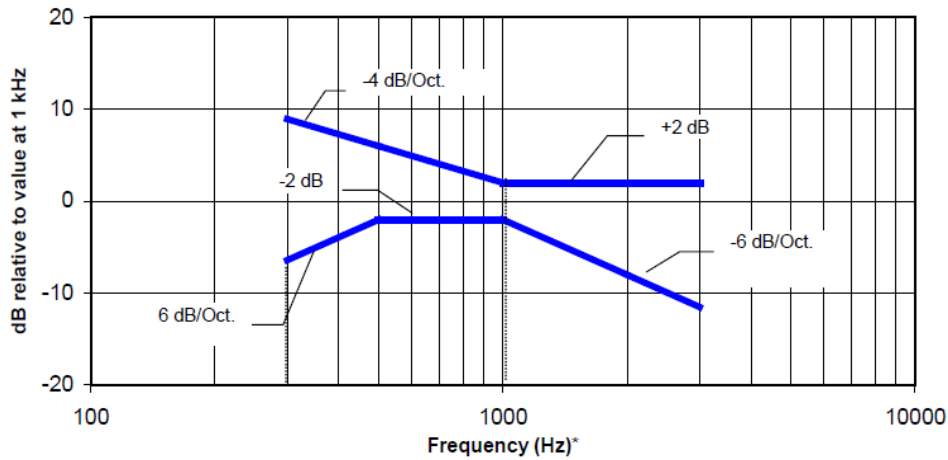

NOTE—Frequency response is between 300 Hz and 3 kHz.

**Figure 6.4—Magnetic field frequency response for WDs with a maximum field  $\leq -15$  dB(A/m) at 1 kHz**

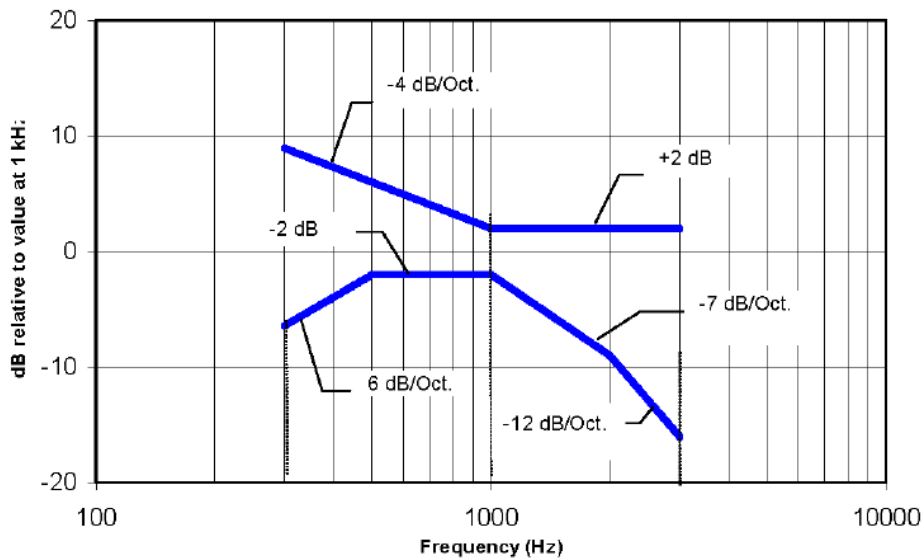

NOTE—Frequency response is between 300 Hz and 3000 Hz.

**Figure 6.5—Magnetic field frequency response for WDs with a maximum field that exceeds  $-15$  dB(A/m) at 1 kHz**

## 7.2. Coupling Mode Requirements

To comply with the requirements for T-Coil use, a WD’s tested operating modes shall simultaneously meet the requirements for minimum desired ABM signal level and maximum undesired ABM field contained in this subclause at the minimum specified number of scanned locations.

When measured as specified in this standard, there are two groups of qualifying measurement points:

*Primary group:* A qualifying measurement point shall have its T-Coil signal, desired ABM signal,  $\geq -18$  dB(A/m) at 1 kHz, in a 1/3 octave band filter. These measurements shall be made with the WD operating at a reference input level as specified in Table 6.1. Simultaneously, the qualifying measurement point shall have its weighted magnetic noise, undesired ABM field  $\leq -38$  dB(A/m).

*Secondary group:* A qualifying measurement point shall have its weighted magnetic noise, undesired ABM field  $\leq -38$  dB(A/m). This group inherently includes all the members of the primary group.

These levels are designed to be compatible with hearing aids that produce the same acoustic output level for either an acoustic input level of 65 dB SPL or a magnetic input level of  $-25$  dB(A/m) (56.2 mA/m)<sup>6</sup> at either 1.0 kHz or 1.6 kHz. The hearing aid operational measurements are performed per ANSI S3.22-2014.

Measurement locations and reference plane to be used for the T-coil measurements.

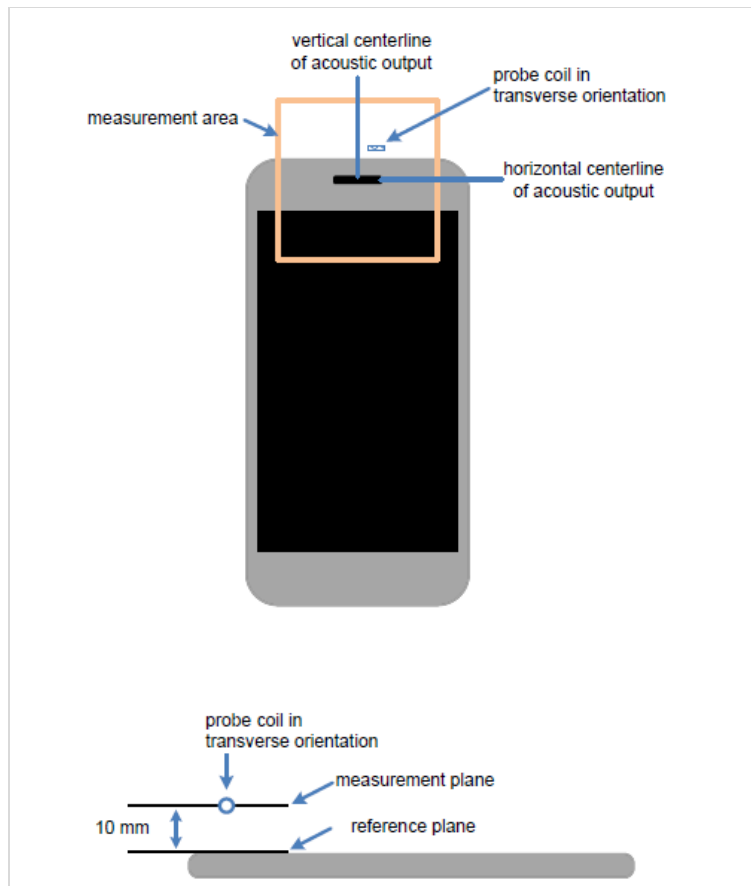

<sup>6</sup> IEC 60118-1 refers to hearing aid output being the same for an acoustic input of 70 dB SPL and a magnetic input of 100 mA/m. Thus 31.6 mA/m is equivalent to an acoustic input of 60 dB SPL, and an acoustic input of 65 dB SPL is equivalent to 56.2 mA/m.

### 7.3. Desired ABM Signal and Undesired ABM Field Requirements

For a WD that is expected to operate primarily in radio access technologies that include 2G GSM for legacy support, the WD shall be qualified for telecoil compatibility one of two ways:

- The DUT shall be rated for telecoil use for all other voice operating modes, exclusive of 2G GSM, according to the criteria of §6.6.4.2 of ANSI C63.19 2019.
- If the DUT is to be rated for telecoil use in its 2G GSM operating modes, these modes shall be qualified according to the criteria of §6.6.4.3 of ANSI C63.19 2019.

#### 7.3.1. Non-2G GSM Operating modes

The goal of this requirement is to ensure an adequate area where desired ABM signal is sufficiently strong to be heard clearly and a larger area where undesired ABM field is sufficiently low as to avoid undue annoyance. Qualifying measurement points shall fulfill the coupling mode requirements; both the primary and secondary group requirements shall be met:

- The primary group shall include at least 75 measurement points.
  - The secondary group shall include at least 300 contiguous measurement points.
- Additionally, to avoid an oddly shaped area of low noise, the secondary group shall include at least one longitudinal column of at least 10 contiguous qualifying points and at least one transverse row containing at least 15 contiguous qualifying points.

#### 7.3.2. 2G GSM Operating modes

For 2G GSM operating mode(s), the qualifying measurement points shall fulfil the coupling mode requirements; both the primary and secondary group requirements shall be met:

- The primary group shall include at least 25 measurement points.
- The secondary group shall include at least 125 contiguous measurement points.

Additionally, to avoid an oddly shaped area of low noise, the secondary group shall include at least one longitudinal column of at least 10 contiguous qualifying points and at least one transverse row containing at least 15 contiguous qualifying points.

### 8. Device Under Test

Normal operation	Held to head		
Back Cover	The Back Cover is not removable		
Test sample information	<b>S/N</b> KJ44DKVK26	<b>IMEI</b> N/A	<b>Notes</b> HAC Sample

#### 8.1. Air Interfaces and Operating Mode

All air interfaces which support voice capabilities over a managed CMRS or pre-installed OTT VoIP applications were tested.

Air Interface	Bands (MHz)	Type	C63.19 Tested	Simultaneous Transmitter	Name of Voice Service	Power Mode <sup>3</sup>	Power Reduction	Audio Codecs Evaluated <sup>1</sup>
GSM	850	VO	Yes	Wi-Fi, BT, NB U-NII, & 802.15.4	CMRS	Power State 1 Mode A	N/A	EFR, AMR-NB & AMR-WB
	1900						N/A	
	GPRS/EDGE	DT/VD	Yes	Wi-Fi, BT, NB U-NII, & 802.15.4	FaceTime	Power State 1 Mode A	N/A	ACC-ELD
W-CDMA (UMTS)	850	VO	Yes	Wi-Fi, BT, NB U-NII, & 802.15.4	CMRS	Power State 1 Mode A	N/A	AMR-NB & AMR-WB
	1700							
	1900	VD	Yes	Wi-Fi, BT, NB U-NII, & 802.15.4	FaceTime	Power State 1 Mode A	N/A	ACC-ELD
LTE - FDD	700 (B12/13/17)	VD	Yes	Wi-Fi, BT, NB U-NII, & 802.15.4	CMRS FaceTime	Power State 1 Mode A	N/A	AMR-NB, AMR-WB, EVS, & ACC-ELD
	850 (B5/26)							
	1700 (B4/66)							
	1900 (B2/25)							
	2300 (B30)							
	2600 (B7)							
LTE - TDD	2600 (B41)	VD	Yes	Wi-Fi, BT, NB U-NII, & 802.15.4	CMRS FaceTime	Power State 1 Mode A	N/A	AMR-NB, AMR-WB, EVS, & ACC-ELD
	3600 (B48)							
5G NR (FR1) FDD	700 (n12)	VD	Yes <sup>2</sup>	Wi-Fi, BT, NB U-NII, & 802.15.4	CMRS FaceTime	Power State 1 Mode A	N/A	AMR-NB, AMR-WB, EVS, & ACC-ELD
	850 (n5/n26)							
	1700 (n66/n70)							
	1900 (n2/n25)							
	2300 (n30)							
	2500 (n7)							
5G NR (FR1) TDD	2600 (n38/n41) <sup>4</sup>	VD	Yes <sup>2</sup>	Wi-Fi, BT, NB U-NII, & 802.15.4	CMRS FaceTime	Power State 1 Mode A	N/A	AMR-NB, AMR-WB, EVS, & ACC-ELD
	3500 (n77 Block A) <sup>4</sup>							
	3700 (n48)							
	3900 (n77 Block C) <sup>4</sup>							

Type  
 VO: Legacy Cellular Voice Service  
 DT: Digital Transport only (no voice)  
 VD: IP Voice Service over Digital Transport  
 CMRS: Commercial Mobile Radio Service

Note(s):

- For protocols not listed in Table 6.1 of ANSI C63.19-2019, the average speech level of -20 dBm0 was used. Refer to §5.2 for reference input levels.
- 5G NR (VoNR) is supported: manufacturer states that 5G NR (VoNR) uses the same protocol, Codec(s) and bitrates as LTE (VoLTE).
- For all air interfaces, the maximum held-to-head output power was used for T-Coil evaluations. The maximum held-to-head output power is Power State 1 Mode A for WWAN operating modes and Power State 1 Mode A for WLAN operating modes. Refer to §9 & §10 for T-Coil evaluations.
- LTE TDD B41 supports Power Class 2 and 3, 5G NR TDD n41 and n77 support Power Class 2 and 3.

**Air Interfaces and Operating Modes**

Air Interface	Bands (MHz)	Type	C63.19 Tested	Simultaneous Transmitter	Name of Voice Service	Power Mode <sup>2</sup>	Power Reduction	Audio Codecs Evaluated <sup>1</sup>
Wi-Fi	2450	VD	Yes	WWAN, Wi-Fi, BT, NB U-NII, & 802.15.4	CMRS FaceTime	Power State 1 Mode A	N/A	AMR-NB, AMR-WB, EVS, & ACC-ELD
	U-NII-1							
	U-NII-2A							
	U-NII-2C							
	U-NII-3	VD	Yes	WWAN, Wi-Fi, BT, NB U-NII, & 802.15.4	CMRS FaceTime	Power State 1 Mode A	N/A	AMR-NB, AMR-WB, EVS, & ACC-ELD
	U-NII-5							
	U-NII-6							
	U-NII-7							
U-NII-8	VD	No <sup>3</sup>	WWAN, Wi-Fi, BT, NB U-NII, & 802.15.4	CMRS FaceTime	Power State 1 Mode A	N/A	N/A	
NB-U-NII	U-NII-1	DT	N/A	WWAN, Wi-Fi, BT, & 802.15.4	N/A	N/A	N/A	N/A
	U-NII-3							
	U-NII-5							
802.15ab NB	U-NII-3	DT	N/A	WWAN, Wi-Fi, BT, & 802.15.4	N/A	N/A	N/A	N/A
802.15.4	2450	DT	N/A	WWAN, Wi-Fi, BT, & NB U-NII	N/A	N/A	N/A	N/A
BT	2450	DT	NA	WWAN, Wi-Fi, NB U-NII, & 802.15.4	NA	N/A	N/A	N/A
MSS	1600	DT	N/A	N/A	N/A	N/A	N/A	N/A
NFC	13	DT	N/A	N/A	N/A	N/A	N/A	N/A
UWB (Ultra-Wideband)	6500	DT	N/A	N/A	N/A	N/A	N/A	N/A
	8000							
Type VO: Legacy Cellular Voice Service DT: Digital Transport only (no voice) VD: IP Voice Service over Digital Transport CMRS: Commercial Mobile Radio Service				Note(s): 1. For protocols not listed in Table 6.1 of ANSI C63.19-2019, the average speech level of -20 dBm0 was used. Refer to §5.2 for reference input levels. 2. For all air interfaces, the maximum held-to-head output power was used for T-Coil evaluations. The maximum held-to-head output power is Power State 1 Mode A for WWAN operating modes and Power State 1 Mode A for WLAN operating modes. Refer to §9 & §10 for T-Coil evaluations 3. Supported Frequency > 6GHz. ANSI C63,19 2019 only requires HAC evaluations for Technologies/Frequencies < 6GHz..				

## 9. Investigations (Codec & Air Interface)

To comply with the requirements for T-Coil use, a WD's tested operating modes shall simultaneously meet the requirements for minimum desired ABM signal level and maximum undesired ABM field contained in this subclause at the minimum specified number of scanned locations.

When measured as specified in this standard, there are two groups of qualifying measurement points:

**Primary group:** A qualifying measurement point shall have its T-Coil signal, desired ABM signal,  $\geq -18$  dB(A/m) at 1 kHz, in a 1/3 octave band filter. These measurements shall be made with the WD operating at a reference input level as specified in Table 6.1. Simultaneously, the qualifying measurement point shall have its weighted magnetic noise, undesired ABM field  $\leq -38$  dB(A/m).

**Secondary group:** A qualifying measurement point shall have its weighted magnetic noise, undesired ABM field  $\leq -38$  dB(A/m). This group inherently includes all the members of the primary group.

### **2G GSM Operating modes**

For 2G GSM operating mode(s), the qualifying measurement points shall fulfil the coupling mode requirements; both the primary and secondary group requirements shall be met:

- The primary group shall include at least 25 measurement points.
- The secondary group shall include at least 125 contiguous measurement points.

Additionally, to avoid an oddly shaped area of low noise, the secondary group shall include at least one longitudinal column of at least 10 contiguous qualifying points and at least one transverse row containing at least 15 contiguous qualifying points.

### **Non-2G GSM Operating modes**

Qualifying measurement points shall fulfill the coupling mode requirements; both the primary and secondary group requirements shall be met:

- The primary group shall include at least 75 measurement points.
- The secondary group shall include at least 300 contiguous measurement points.

Additionally, to avoid an oddly shaped area of low noise, the secondary group shall include at least one longitudinal column of at least 10 contiguous qualifying points and at least one transverse row containing at least 15 contiguous qualifying points.

### **5G NR Operating modes**

The DUT supports 5G NR, Voice over New Radio (VoNR). Per the manufacturer, 5G NR (VoNR) uses the same protocol, Codec(s) and bitrates as LTE (VoLTE). Investigations were performed on LTE (VoLTE) and the worst-case Codec & Air Interface configurations from LTE (VoLTE) was used for 5G NR (VoNR) evaluations. Refer to §10 for 5G NR (VoNR) evaluations.

### **All Operating modes**

For all air interfaces, the maximum held-to-head output power was used for T-Coil evaluations. The maximum held-to-head output power is Power State 1 Mode A for WWAN operating modes and Power State 1 Mode A for WLAN operating modes. Refer to §9 & §10 for T-Coil evaluations.

The worst-case configuration is determined by the lowest margin of Primary Group Contiguous Points. The margin Primary Group Contiguous Points is calculated by subtracting the Primary Group points coupling mode requirement (25 for GSM modes and 75 for non-GSM modes) from the measured Primary Group Contiguous Points. The lowest margin of Primary Group Contiguous Points will be highlighted in each table.

For WWAN technologies, the DUT utilizes an Antenna - Port mapping feature. A Port is a collection (cluster) of antennas. Once the Port and Frequency Band has been selected, the transmitting Antenna is auto selected. Below is a description of the Port - Antenna mapping for the DUT.

Port	Frequency Band	Antenna
A	LB	3
	LMB	3
	MBHB	3
	UHB	9
B	LB	2
	LMB	2
	MBHB	4
	UHB	8
C	MBHB	2
	UHB	4
D	MBHB	1
	UHB	7

LB = Lower Band (617 MHz - 960 MHz)

LMB = Lower - Mid Band (1427 MHz - 1700 MHz)

MBHB = Mid Band - High Band (1710 MHz - 2960 MHz)

UHB = Ultra High Band (3300 MHz - 4200 MHz)

An investigation was performed to determine the worst-case Port for each Licensed technology. All subsequent measurements were determined by this investigation.

The device supports (4) WLAN Tx antennas:

Antenna	Technology
1 (Lower)	Wi-Fi 2.4 GHz
	Bluetooth
2 (Upper)	Wi-Fi 2.4 GHz
	Bluetooth
5 (Lower)	Wi-Fi 5 & 6 GHz
6 (Upper)	Wi-Fi 5 & 6 GHz

An investigation was performed to determine the worst-case WLAN Antenna. All subsequent measurements were determined by this investigation.

## 9.1. Codec Investigations

CMRS and OTT voice services support the same technologies, antennas and air interfaces. CMRS and OTT voice services require the same Reference input level of -16 dBm0 per ANSI C63.19 2019 §6. An investigation between the various supported codec configurations (Low/Mid/High bit rates for EFR, AMR-NB, AMR-WB, EVS and OTT application) was performed to determine the worst-case codec and bit rate. The table below compares the varying codec configurations. A codec investigation was performed on one band of each technology: GSM, W-CDMA, LTE FDD, LTE TDD, WLAN 2.4GHz and WLAN 5GHz. The worst-case codec/bit rate determined for each technology will be used for all subsequent testing for the respective technology.

The supported OTT Application does not support a means for the test lab to change the codec's (ACC-ELD) bit rates. When a VoIP call was established, the test lab recorded the bit rate used during that session, listed below, for the supported technologies: GSM, W-CDMA, LTE, 5G NR, WLAN 2.4 GHz, and WLAN 5 GHz.

### ACC-ELD Codec Bit Rates

Codec Bit Rate			
Technology	Mode	Codec	Bit Rate (kbps)
GSM	EDGE	ACC-ELD	44
W-CDMA	HSPA	ACC-ELD	28
LTE	FDD	ACC-ELD	49
	TDD	ACC-ELD	49
5G NR	FDD	ACC-ELD	49
	TDD	ACC-ELD	49
WLAN 2.4 GHz	802.11b	ACC-ELD	60
	802.11g	ACC-ELD	60
	802.11n HT20	ACC-ELD	60
	802.11n HT20	ACC-ELD	60
	802.11ac VHT20	ACC-ELD	60
	802.11ac VHT40	ACC-ELD	60
	802.11ax HE20	ACC-ELD	60
	802.11ax HE40	ACC-ELD	60
	802.11be EHT20	ACC-ELD	60
WLAN 5 GHz	802.11a	ACC-ELD	60
	802.11n HT20	ACC-ELD	60
	802.11n HT40	ACC-ELD	60
	802.11ac VHT20	ACC-ELD	60
	802.11ac VHT40	ACC-ELD	60
	802.11ac VHT80	ACC-ELD	60
	802.11ac VHT160	ACC-ELD	60
	802.11ax HE20	ACC-ELD	60
	802.11ax HE40	ACC-ELD	60
	802.11ax HE80	ACC-ELD	60
	802.11ax HE160	ACC-ELD	60
	802.11be EHT20	ACC-ELD	60
	802.11be EHT40	ACC-ELD	60
802.11be EHT80	ACC-ELD	60	
802.11be EHT160	ACC-ELD	60	
WLAN 6 GHz	802.11be EHT320	ACC-ELD	60



**GSM Codec Investigation**

GSM Codec Investigation														
Band / Mode	Channel and Frequency	Power Mode	Port/ANT	Codec	Bitrate (kbps)	Orientation	Frequency Response	Ambient Noise dB(A/m)	Primary Group Contiguous Pts	Secondary Group Contiguous Pts	Secondary Group Max Longitudinal	Secondary Group Max Transverse	Primary Group Contiguous Pts Margin	Secondary Group Contiguous Pts Margin
GSM 1900 Voice Coder Speechcodec Low	661 1880 MHz	Mode A	B (ANT 2)	EFR	12.2	Transverse	Pass	-51.56	305	563	26	26	280	438
GSM 1900 Voice Coder Speechcodec Low	661 1880 MHz	Mode A	B (ANT 2)	AMR-NB	4.75	Transverse	Pass	-51.56	309	571	26	26	284	446
GSM 1900 Voice Coder Speechcodec Low	661 1880 MHz	Mode A	B (ANT 2)	AMR-NB	7.4	Transverse	Pass	-51.56	310	565	26	26	285	440
GSM 1900 Voice Coder Speechcodec Low	661 1880 MHz	Mode A	B (ANT 2)	AMR-NB	12.2	Transverse	Pass	-51.56	315	566	26	26	290	441
GSM 1900 Voice Coder Speechcodec Low	661 1880 MHz	Mode A	B (ANT 2)	AMR-WB	6.6	Transverse	Pass	-51.56	245	564	26	26	220	439
GSM 1900 Voice Coder Speechcodec Low	661 1880 MHz	Mode A	B (ANT 2)	AMR-WB	8.85	Transverse	Pass	-51.56	262	567	26	26	237	442
GSM 1900 Voice Coder Speechcodec Low	661 1880 MHz	Mode A	B (ANT 2)	AMR-WB	12.65	Transverse	Pass	-51.56	259	564	26	26	234	439
GSM 1900 EDGE/EGFRS 2 Slot(s)	661 1880 MHz	Mode A	B (ANT 2)	ACC-ELD	44	Transverse	Pass	-51.55	182	558	26	26	157	433

**Note(s):**

- For GSM, it is observed that ACC-ELD is the worst-case bit rate.

**W-CDMA Codec Investigation**

W-CDMA Codec Investigation														
Band / Mode	Channel and Frequency	Power Mode	Port/ANT	Codec	Bitrate (kbps)	Orientation	Frequency Response	Ambient Noise dB(A/m)	Primary Group Contiguous Pts	Secondary Group Contiguous Pts	Secondary Group Max Longitudinal	Secondary Group Max Transverse	Primary Group Contiguous Pts Margin	Secondary Group Contiguous Pts Margin
W-CDMA Bit Rel. 99	9400 1880 MHz	Mode A	B (ANT 2)	AMR-NB	4.75	Transverse	Pass	-51.56	369	622	26	26	294	322
W-CDMA Bit Rel. 99	9400 1880 MHz	Mode A	B (ANT 2)	AMR-NB	7.40	Transverse	Pass	-51.56	380	634	26	26	305	334
W-CDMA Bit Rel. 99	9400 1880 MHz	Mode A	B (ANT 2)	AMR-NB	12.20	Transverse	Pass	-51.56	381	632	26	26	306	332
W-CDMA Bit Rel. 99	9400 1880 MHz	Mode A	B (ANT 2)	AMR-WB	6.60	Transverse	Pass	-51.56	314	634	26	26	239	334
W-CDMA Bit Rel. 99	9400 1880 MHz	Mode A	B (ANT 2)	AMR-WB	15.85	Transverse	Pass	-51.56	321	619	26	26	246	319
W-CDMA Bit Rel. 99	9400 1880 MHz	Mode A	B (ANT 2)	AMR-WB	23.85	Transverse	Pass	-51.56	329	630	26	26	254	330
W-CDMA Bit HSPA	9400 1880 MHz	Mode A	B (ANT 2)	ACC-ELD	28	Transverse	Pass	-51.56	253	629	26	26	178	329

**Note(s):**

- For W-CDMA, it is observed that ACC-ELD is the worst-case bit rate.

**LTE (VoLTE) FDD Codec Investigation**

LTE FDD Codec Investigation														
Band / Mode	Channel and Frequency	Power Mode	Port/ANT	Codec	Bitrate (kbps)	Orientation	Frequency Response	Ambient Noise dB(A/m)	Primary Group Contiguous Pts	Secondary Group Contiguous Pts	Secondary Group Max Longitudinal	Secondary Group Max Transverse	Primary Group Contiguous Pts Margin	Secondary Group Contiguous Pts Margin
LTE Band 25 QPSK RB 1/0 20 MHz BW	26365 1882.5 MHz	Mode A	B (ANT 2)	AMR-NB	4.75	Transverse	Pass	-51.55	368	635	26	26	293	335
LTE Band 25 QPSK RB 1/0 20 MHz BW	26365 1882.5 MHz	Mode A	B (ANT 2)	AMR-NB	7.4	Transverse	Pass	-51.55	375	641	26	26	300	341
LTE Band 25 QPSK RB 1/0 20 MHz BW	26365 1882.5 MHz	Mode A	B (ANT 2)	AMR-NB	12.2	Transverse	Pass	-51.55	376	639	26	26	301	339
LTE Band 25 QPSK RB 1/0 20 MHz BW	26365 1882.5 MHz	Mode A	B (ANT 2)	AMR-WB	6.6	Transverse	Pass	-51.55	304	629	26	26	229	329
LTE Band 25 QPSK RB 1/0 20 MHz BW	26365 1882.5 MHz	Mode A	B (ANT 2)	AMR-WB	15.85	Transverse	Pass	-51.55	325	642	26	26	250	342
LTE Band 25 QPSK RB 1/0 20 MHz BW	26365 1882.5 MHz	Mode A	B (ANT 2)	AMR-WB	23.85	Transverse	Pass	-51.55	341	659	26	26	266	359
LTE Band 25 QPSK RB 1/0 20 MHz BW	26365 1882.5 MHz	Mode A	B (ANT 2)	EVS	5.9	Transverse	Pass	-51.55	317	660	26	26	242	360
LTE Band 25 QPSK RB 1/0 20 MHz BW	26365 1882.5 MHz	Mode A	B (ANT 2)	EVS	9.6	Transverse	Pass	-51.55	402	662	26	26	327	362
LTE Band 25 QPSK RB 1/0 20 MHz BW	26365 1882.5 MHz	Mode A	B (ANT 2)	EVS	24.4	Transverse	Pass	-51.55	401	660	26	26	326	360
LTE Band 25 QPSK RB 1/0 20 MHz BW	26365 1882.5 MHz	Mode A	B (ANT 2)	ACC-ELD	49	Transverse	Pass	-51.55	243	615	26	26	168	315

**Note(s):**

- For LTE-FDD, it is observed that ACC-ELD is the worst-case bit rate.

**LTE (VoLTE) TDD Codec Investigation**

LTE TDD Codec Investigation														
f0de	Channel and Frequency	Power Mode	Port/ANT	Codec	Bitrate (kbps)	Orientation	Frequency Response	Ambient Noise dB(A/m)	Primary Group Contiguous Pts	Secondary Group Contiguous Pts	Secondary Group Max Longitudinal	Secondary Group Max Transverse	Primary Group Contiguous Pts Margin	Secondary Group Contiguous Pts Margin
LTE Band 41 QPSK RB 1/0 20 MHz BW	40620 2593 MHz	Mode A	B (ANT 2)	AMR-NB	4.75	Transverse	Pass	-51.55	370	634	26	26	295	334
LTE Band 41 QPSK RB 1/0 20 MHz BW	40620 2593 MHz	Mode A	B (ANT 2)	AMR-NB	7.4	Transverse	Pass	-51.55	366	628	26	26	291	328
LTE Band 41 QPSK RB 1/0 20 MHz BW	40620 2593 MHz	Mode A	B (ANT 2)	AMR-NB	12.2	Transverse	Pass	-51.55	374	631	26	26	299	331
LTE Band 41 QPSK RB 1/0 20 MHz BW	40620 2593 MHz	Mode A	B (ANT 2)	AMR-WB	6.6	Transverse	Pass	-51.55	292	612	26	26	217	312
LTE Band 41 QPSK RB 1/0 20 MHz BW	40620 2593 MHz	Mode A	B (ANT 2)	AMR-WB	15.85	Transverse	Pass	-51.55	300	604	26	26	225	304
LTE Band 41 QPSK RB 1/0 20 MHz BW	40620 2593 MHz	Mode A	B (ANT 2)	AMR-WB	23.85	Transverse	Pass	-51.55	293	592	26	26	218	292
LTE Band 41 QPSK RB 1/0 20 MHz BW	40620 2593 MHz	Mode A	B (ANT 2)	EVS	5.9	Transverse	Pass	-51.55	285	621	26	26	210	321
LTE Band 41 QPSK RB 1/0 20 MHz BW	40620 2593 MHz	Mode A	B (ANT 2)	EVS	9.6	Transverse	Pass	-51.55	372	624	26	26	297	324
LTE Band 41 QPSK RB 1/0 20 MHz BW	40620 2593 MHz	Mode A	B (ANT 2)	EVS	24.4	Transverse	Pass	-51.55	370	622	26	26	295	322
LTE Band 41 QPSK RB 1/0 20 MHz BW	40620 2593 MHz	Mode A	B (ANT 2)	ACC-ELD	49	Transverse	Pass	-51.55	225	601	26	26	150	301

**Note(s):**

- For LTE-TDD, it is observed that ACC-ELD is the worst-case bit rate.

**WLAN (VoWiFi) 2.4 GHz Codec Interface Investigation**

Wi-Fi 2.4GHz Codec Investigation														
f0de	Channel and Frequency	Power Mode	Port/ANT	Codec	Bitrate (kbps)	Orientation	Frequency Response	Ambient Noise dB(A/m)	Primary Group Contiguous Pts	Secondary Group Contiguous Pts	Secondary Group Max Longitudinal	Secondary Group Max Transverse	Primary Group Contiguous Pts Margin	Secondary Group Contiguous Pts Margin
802.11b DSSS 1 Mbps 20 MHz BW	6 2437 MHz	Power State 1 Head	ANT 2	AMR-NB	4.75	Transverse	Pass	-51.54	283	582	26	26	208	282
802.11b DSSS 1 Mbps 20 MHz BW	6 2437 MHz	Power State 1 Head	ANT 2	AMR-NB	7.4	Transverse	Pass	-51.54	269	572	26	26	194	272
802.11b DSSS 1 Mbps 20 MHz BW	6 2437 MHz	Power State 1 Head	ANT 2	AMR-NB	12.2	Transverse	Pass	-51.54	272	570	26	26	197	270
802.11b DSSS 1 Mbps 20 MHz BW	6 2437 MHz	Power State 1 Head	ANT 2	AMR-WB	6.6	Transverse	Pass	-51.54	251	615	26	26	176	315
802.11b DSSS 1 Mbps 20 MHz BW	6 2437 MHz	Power State 1 Head	ANT 2	AMR-WB	15.85	Transverse	Pass	-51.54	249	600	26	26	174	300
802.11b DSSS 1 Mbps 20 MHz BW	6 2437 MHz	Power State 1 Head	ANT 2	AMR-WB	23.85	Transverse	Pass	-51.54	242	592	26	26	167	292
802.11b DSSS 1 Mbps 20 MHz BW	6 2437 MHz	Power State 1 Head	ANT 2	EVS	5.9	Transverse	Pass	-51.54	202	519	26	26	127	219
802.11b DSSS 1 Mbps 20 MHz BW	6 2437 MHz	Power State 1 Head	ANT 2	EVS	9.6	Transverse	Pass	-51.54	212	514	26	26	137	214
802.11b DSSS 1 Mbps 20 MHz BW	6 2437 MHz	Power State 1 Head	ANT 2	EVS	24.4	Transverse	Pass	-51.54	240	542	26	26	165	242
802.11b DSSS 1 Mbps 20 MHz BW	6 2437 MHz	Power State 1 Head	ANT 2	ACC-ELD	60	Transverse	Pass	-51.54	241	616	26	26	166	316

**Note(s):**

- For Wi-Fi 2.4 GHz, it is observed that 5.90 kbps is the worst-case bit rate.

**WLAN (VoWiFi) 5 GHz Codec Interface Investigation**

Wi-Fi 5GHz Codec Investigation															
Mode	Channel and Frequency	Power Mode	Port/ANT	Codec	Bitrate (kbps)	Orientation	Frequency Response	Ambient Noise dB(A/m)	Primary Group Contiguous Pts	Secondary Group Contiguous Pts	Secondary Group Max Longitudinal	Secondary Group Max Transverse	Primary Group Contiguous Pts Margin	Secondary Group Contiguous Pts Margin	
802.11a BPSK 6 Mbps 20 MHz BW	36 5180 MHz	Power State 1 Head	ANT 6	AMR-NB	4.75	Transverse	Pass	-51.54	271	584	26	26	196	284	
802.11a BPSK 6 Mbps 20 MHz BW	36 5180 MHz	Power State 1 Head	ANT 6	AMR-NB	7.4	Transverse	Pass	-51.54	270	583	26	26	195	283	
802.11a BPSK 6 Mbps 20 MHz BW	36 5180 MHz	Power State 1 Head	ANT 6	AMR-NB	12.2	Transverse	Pass	-51.54	262	563	26	26	187	263	
802.11a BPSK 6 Mbps 20 MHz BW	36 5180 MHz	Power State 1 Head	ANT 6	AMR-WB	6.6	Transverse	Pass	-51.54	250	612	26	26	175	312	
802.11a BPSK 6 Mbps 20 MHz BW	36 5180 MHz	Power State 1 Head	ANT 6	AMR-WB	15.85	Transverse	Pass	-51.54	250	600	26	26	175	300	
802.11a BPSK 6 Mbps 20 MHz BW	36 5180 MHz	Power State 1 Head	ANT 6	AMR-WB	23.85	Transverse	Pass	-51.49	215	590	26	26	140	290	
802.11a BPSK 6 Mbps 20 MHz BW	36 5180 MHz	Power State 1 Head	ANT 6	EVS	5.9	Transverse	Pass	-51.49	196	523	26	26	121	223	
802.11a BPSK 6 Mbps 20 MHz BW	36 5180 MHz	Power State 1 Head	ANT 6	EVS	9.6	Transverse	Pass	-51.49	215	526	26	26	140	226	
802.11a BPSK 6 Mbps 20 MHz BW	36 5180 MHz	Power State 1 Head	ANT 6	EVS	24.4	Transverse	Pass	-51.49	239	544	26	26	164	244	
802.11a BPSK 6 Mbps 20 MHz BW	36 5180 MHz	Power State 1 Head	ANT 6	ACC-ELD	60	Transverse	Pass	-51.49	237	619	26	26	162	319	

**Note(s):**

- For Wi-Fi 5 GHz, it is observed that 5.90 kbps is the worst-case bit rate.

## 9.2. Air Interface Investigation

A limited set of bands/channels/bandwidths were tested to confirm that there is no effect on the ABM levels when changing the band/channel/bandwidth.

### GSM Air Interface Investigation

GSM Air Interface Investigation													
Band / Mode	Channel and Frequency	Power Mode	Port/ANT	Codec and Bit rate (kbps)	Orientation	Frequency Response	Ambient Noise dB(A/m)	Primary Group Contiguous Pts	Secondary Group Contiguous Pts	Secondary Group Max Longitudinal	Secondary Group Max Transverse	Primary Group Contiguous Pts Margin	Secondary Group Contiguous Pts Margin
GSM 1900 EDGE/EGPRS 2 Slot(s)	512 1850.2 MHz	Mode A	B (ANT 2)	ACC-ELD: 44 kbps	Transverse	Pass	-51.55	186	558	26	26	161	433
GSM 1900 EDGE/EGPRS 2 Slot(s)	661 1880.0 MHz	Mode A	B (ANT 2)	ACC-ELD: 44 kbps	Transverse	Pass	-51.55	182	558	26	26	157	433
GSM 1900 EDGE/EGPRS 2 Slot(s)	810 1909.8 MHz	Mode A	B (ANT 2)	ACC-ELD: 44 kbps	Transverse	Pass	-51.55	189	562	26	26	164	437

**Note(s):**

For all subsequent tests for GSM, middle channel was used in conjunction with the worst-case bit rate found in §9.1.

### W-CDMA Air Interface Investigation

W-CDMA Air Interface Investigation													
Band / Mode	Channel and Frequency	Power Mode	Port/ANT	Codec and Bit rate (kbps)	Orientation	Frequency Response	Ambient Noise dB(A/m)	Primary Group Contiguous Pts	Secondary Group Contiguous Pts	Secondary Group Max Longitudinal	Secondary Group Max Transverse	Primary Group Contiguous Pts Margin	Secondary Group Contiguous Pts Margin
W-CDMA BII HSPA	9262 1852.4 MHz	Mode A	B (ANT 2)	ACC-ELD: 28 kbps	Transverse	Pass	-51.56	255	630	26	26	180	330
W-CDMA BII HSPA	9400 1880.0 MHz	Mode A	B (ANT 2)	ACC-ELD: 28 kbps	Transverse	Pass	-51.56	253	629	26	26	178	329
W-CDMA BII HSPA	9538 1907.6 MHz	Mode A	B (ANT 2)	ACC-ELD: 28 kbps	Transverse	Pass	-51.56	249	629	26	26	174	329

**Note(s):**

For all subsequent tests for W-CDMA, high channel was used in conjunction with the worst-case bit rate found in §9.1.

### LTE (VoLTE) Air Interface Investigation

LTE Air Interface Investigation																
Band / Mode	Channel and Frequency	Channel Bandwidth	Power Mode	Port/ANT	RB Allocation		Codec and Bit rate (kbps)	Orientation	Frequency Response	Ambient Noise dB(A/m)	Primary Group Contiguous Pts	Secondary Group Contiguous Pts	Secondary Group Max Longitudinal	Secondary Group Max Transverse	Primary Group Contiguous Pts Margin	Secondary Group Contiguous Pts Margin
LTE Band 25 QPSK	26365 1882.5 MHz	20 MHz	Mode A	B (ANT 2)	1	0	ACC-ELD: 49 kbps	Transverse	Pass	-51.55	243	615	26	26	168	315
LTE Band 25 QPSK	26365 1882.5 MHz	20 MHz	Mode A	B (ANT 2)	100	0	ACC-ELD: 49 kbps	Transverse	Pass	-51.55	243	616	26	26	168	316
LTE Band 25 16QAM	26365 1882.5 MHz	20 MHz	Mode A	B (ANT 2)	1	0	ACC-ELD: 49 kbps	Transverse	Pass	-51.55	244	618	26	26	169	318
LTE Band 25 64QAM	26365 1882.5 MHz	20 MHz	Mode A	B (ANT 2)	1	0	ACC-ELD: 49 kbps	Transverse	Pass	-51.55	245	619	26	26	170	319
LTE Band 25 256QAM	26365 1882.5 MHz	20 MHz	Mode A	B (ANT 2)	1	0	ACC-ELD: 49 kbps	Transverse	Pass	-51.55	245	618	26	26	170	318
LTE Band 25 QPSK	26365 1882.5 MHz	1.4 MHz	Mode A	B (ANT 2)	1	0	ACC-ELD: 49 kbps	Transverse	Pass	-51.55	248	621	26	26	173	321
LTE Band 41 QPSK	40620 2593 MHz	20 MHz	Mode A	B (ANT 2)	1	0	ACC-ELD: 49 kbps	Transverse	Pass	-51.55	225	601	26	26	150	301
LTE Band 41 QPSK	40620 2593 MHz	20 MHz	Mode A	B (ANT 2)	100	0	ACC-ELD: 49 kbps	Transverse	Pass	-51.55	226	598	26	26	151	298
LTE Band 41 16QAM	40620 2593 MHz	20 MHz	Mode A	B (ANT 2)	1	0	ACC-ELD: 49 kbps	Transverse	Pass	-51.55	222	596	26	26	147	296
LTE Band 41 64QAM	40620 2593 MHz	20 MHz	Mode A	B (ANT 2)	1	0	ACC-ELD: 49 kbps	Transverse	Pass	-51.55	228	585	26	26	153	285
LTE Band 41 256QAM	40620 2593 MHz	20 MHz	Mode A	B (ANT 2)	1	0	ACC-ELD: 49 kbps	Transverse	Pass	-51.55	224	602	26	26	149	302
LTE Band 41 16QAM	40620 2593 MHz	5 MHz	Mode A	B (ANT 2)	1	0	ACC-ELD: 49 kbps	Transverse	Pass	-51.55	244	617	26	26	169	317

**Note(s):**

For all subsequent tests for LTE-FDD, middle channel, QPSK modulation, and 1% RB size and low RB allocation was used in conjunction with the worst-case bit rate found in §9.1.

For all subsequent tests for LTE-TDD, middle channel, 16QAM modulation, and 1% RB size and low RB allocation was used in conjunction with the worst-case bit rate found in §9.1.

**WLAN (VoWiFi) Air Interface Investigation**

WLAN (VoWiFi) Air Interface Investigation															
Band / Mode	Channel and Frequency	Power Mode	Port/ANT	Codec and Bit rate (kbps)	Modulation/ Index	Data Rate	Orientation	Frequency Response	Ambient Noise dB(A/m)	Primary Group Contiguous Pts	Secondary Group Contiguous Pts	Secondary Group Max Longitudinal	Secondary Group Max Transverse	Primary Group Contiguous Pts Margin	Secondary Group Contiguous Pts Margin
802.11b 20 MHz BW	6 2437 MHz	Power State 1 Head	ANT 2	EV5: 5.9 kbps	DSSS	1 Mbps	Transverse	Pass	-51.54	202	519	26	26	127	219
802.11b 20 MHz BW	6 2437 MHz	Power State 1 Head	ANT 2	EV5: 5.9 kbps	CCK	5.5 Mbps	Transverse	Pass	-51.54	197	511	26	26	122	211
802.11b 20 MHz BW	6 2437 MHz	Power State 1 Head	ANT 2	EV5: 5.9 kbps	CCK	11 Mbps	Transverse	Pass	-51.54	208	519	26	26	133	219
802.11g 20 MHz BW	6 2437 MHz	Power State 1 Head	ANT 2	EV5: 5.9 kbps	QPSK	12 Mbps	Transverse	Pass	-51.54	197	518	26	26	122	218
802.11n HT20 20 MHz BW	6 2437 MHz	Power State 1 Head	ANT 2	EV5: 5.9 kbps	MCS3	26 Mbps	Transverse	Pass	-51.54	198	515	26	26	123	215
802.11n HT40 40 MHz BW	9 2452 MHz	Power State 1 Head	ANT 2	EV5: 5.9 kbps	MCS3	54 Mbps	Transverse	Pass	-51.54	198	517	26	26	123	217
802.11ax HE20 20 MHz BW	6 2437 MHz	Power State 1 Head	ANT 2	EV5: 5.9 kbps	MCS5	68.8 Mbps	Transverse	Pass	-51.54	200	512	26	26	125	212
802.11a 20 MHz BW	36 5180 MHz	Power State 1 Head	ANT 6	EV5: 5.9 kbps	BPSK	6 Mbps	Transverse	Pass	-51.49	196	523	26	26	121	223
802.11a 20 MHz BW	36 5180 MHz	Power State 1 Head	ANT 6	EV5: 5.9 kbps	QPSK	18 Mbps	Transverse	Pass	-51.49	197	516	26	26	122	216
802.11a 20 MHz BW	36 5180 MHz	Power State 1 Head	ANT 6	EV5: 5.9 kbps	64QAM	54 Mbps	Transverse	Pass	-51.49	201	517	26	26	126	217
802.11n HT20 20 MHz BW	36 5180 MHz	Power State 1 Head	ANT 6	EV5: 5.9 kbps	MCS0	6.5 Mbps	Transverse	Pass	-51.49	188	517	26	26	113	217
802.11n HT40 40 MHz BW	38 5190 MHz	Power State 1 Head	ANT 6	EV5: 5.9 kbps	MCS0	13.5 Mbps	Transverse	Pass	-51.49	191	516	26	26	116	216
802.11ac VHT20 20 MHz BW	36 5180 MHz	Power State 1 Head	ANT 6	EV5: 5.9 kbps	MCS0	6.5 Mbps	Transverse	Pass	-51.49	196	519	26	26	121	219
802.11ac VHT40 40 MHz BW	38 5190 MHz	Power State 1 Head	ANT 6	EV5: 5.9 kbps	MCS0	13.5 Mbps	Transverse	Pass	-51.49	199	519	26	26	124	219
802.11ac VHT80 80 MHz BW	42 5210 MHz	Power State 1 Head	ANT 6	EV5: 5.9 kbps	MCS0	29.3 Mbps	Transverse	Pass	-51.49	196	518	26	26	121	218
802.11ac VHT160 160 MHz BW	50 5250 MHz	Power State 1 Head	ANT 6	EV5: 5.9 kbps	MCS0	58.5 Mbps	Transverse	Pass	-51.49	193	513	26	26	118	213
802.11ax HE20 20 MHz BW	36 5180 MHz	Power State 1 Head	ANT 6	EV5: 5.9 kbps	MCS0	8.6 Mbps	Transverse	Pass	-51.49	191	516	26	26	116	216
802.11ax HE40 40 MHz BW	38 5190 MHz	Power State 1 Head	ANT 6	EV5: 5.9 kbps	MCS0	17.2 Mbps	Transverse	Pass	-51.49	188	516	26	26	113	216
802.11ax HE80 80 MHz BW	42 5210 MHz	Power State 1 Head	ANT 6	EV5: 5.9 kbps	MCS0	36 Mbps	Transverse	Pass	-51.49	190	515	26	26	115	215
802.11ax HE160 160 MHz BW	50 5250 MHz	Power State 1 Head	ANT 6	EV5: 5.9 kbps	MCS0	72 Mbps	Transverse	Pass	-51.49	194	515	26	26	119	215

**Note(s):**

For all subsequent tests for 2.4 GHz, 802.11b CCK 5.5 Mbps was used in conjunction with the worst-case bit rate found in §9.1.

For all subsequent tests for 5 GHz, 802.11ax HE40 MHz MCS0 17.2 Mbps was used in conjunction with the worst-case bit rate found in §9.1.

# 10. HAC (T-coil) Test Results

The worst-case codec/bit rate and Air interface determined in §9.1 and §9.2 for each technology was used for HAC T-Coil evaluations. Refer to the tables below for HAC T-Coil Test Results.

## GSM & W-CDMA Test Results

Band / Mode	Channel and Frequency	Power Mode	Port/ANT	Codec and Bit rate (kbps)	Orientation	Frequency Response	Ambient Noise dB(A/m)	Primary Group Contiguous Pts	Secondary Group Contiguous Pts	Secondary Group Max Longitudinal	Secondary Group Max Transverse	Primary Group Contiguous Pts Margin	Secondary Group Contiguous Pts Margin	Plot Page #
GSM 850 EDGE/EGPRS 2 Slot(s)	190 836.6 MHz	Mode A	B (ANT 2)	ACC-ELD: 44 kbps	Transverse	Pass	-51.55	136	516	26	26	111	391	1 - 2
GSM 1900 EDGE/EGPRS 2 Slot(s)	661 1880.0 MHz	Mode A	B (ANT 2)	ACC-ELD: 44 kbps	Transverse	Pass	-51.55	182	558	26	26	157	433	3 - 4
W-CDMA BII HSPA	9538 1907.6 MHz	Mode A	B (ANT 2)	ACC-ELD: 28 kbps	Transverse	Pass	-51.56	249	629	26	26	174	329	5 - 6
W-CDMA BIV HSPA	1513 1752.6 MHz	Mode A	B (ANT 2)	ACC-ELD: 28 kbps	Transverse	Pass	-51.56	248	632	26	26	173	332	7 - 8
W-CDMA Band V HSPA	4233 846.6 MHz	Mode A	B (ANT 2)	ACC-ELD: 28 kbps	Transverse	Pass	-51.56	253	632	26	26	178	332	9 - 10

## LTE (VoLTE) Test Results

Band / Mode	Channel and Frequency	Channel Bandwidth	Power Mode	Port/ANT	RB Allocation	Codec and Bit rate (kbps)	Orientation	Frequency Response	Ambient Noise dB(A/m)	Primary Group Contiguous Pts	Secondary Group Contiguous Pts	Secondary Group Max Longitudinal	Secondary Group Max Transverse	Primary Group Contiguous Pts Margin	Secondary Group Contiguous Pts Margin	Plot Page #
LTE Band 7 QPSK	21100 2535 MHz	20 MHz	Mode A	B (ANT 2)	1 0	ACC-ELD: 49 kbps	Transverse	Pass	-51.43	240	615	26	26	165	315	11 - 12
LTE Band 12 QPSK	23095 707.5 MHz	10 MHz	Mode A	B (ANT 2)	1 0	ACC-ELD: 49 kbps	Transverse	Pass	-51.43	240	624	26	26	165	324	13 - 14
LTE Band 13 QPSK	23230 782 MHz	10 MHz	Mode A	B (ANT 2)	1 0	ACC-ELD: 49 kbps	Transverse	Pass	-51.43	225	603	26	26	150	303	15 - 16
LTE Band 25 QPSK	26365 1882.5 MHz	20 MHz	Mode A	B (ANT 2)	1 0	ACC-ELD: 49 kbps	Transverse	Pass	-51.55	243	615	26	26	168	315	17 - 18
LTE Band 26 QPSK	26865 831.5 MHz	15 MHz	Mode A	B (ANT 2)	1 0	ACC-ELD: 49 kbps	Transverse	Pass	-51.43	232	611	26	26	157	311	19 - 20
LTE Band 30 QPSK	27710 2310 MHz	10 MHz	Mode A	B (ANT 2)	1 0	ACC-ELD: 49 kbps	Transverse	Pass	-51.43	229	607	26	26	154	307	21 - 22
LTE Band 66 QPSK	132322 1745 MHz	20 MHz	Mode A	B (ANT 2)	1 0	ACC-ELD: 49 kbps	Transverse	Pass	-51.43	231	608	26	26	156	308	23 - 24
LTE Band 38 PC3 16QAM	38000 2595 MHz	20 MHz	Mode A	B (ANT 2)	1 0	ACC-ELD: 49 kbps	Transverse	Pass	-51.43	217	587	26	26	142	287	25 - 26
LTE Band 41 PC3 16QAM	40620 2593 MHz	20 MHz	Mode A	B (ANT 2)	1 0	ACC-ELD: 49 kbps	Transverse	Pass	-51.55	222	596	26	26	147	296	27 - 28
LTE Band 41 PC2 16QAM	40620 2593 MHz	20 MHz	Mode A	B (ANT 2)	1 0	ACC-ELD: 49 kbps	Transverse	Pass	-51.43	220	581	26	26	145	281	29 - 30
LTE Band 48 PC3 16QAM	55990 3625 MHz	20 MHz	Mode A	B (ANT 8)	1 0	ACC-ELD: 49 kbps	Transverse	Pass	-51.43	240	616	26	26	165	316	31 - 32
LTE Band 53 PC3 16QAM	60197 2489.2 MHz	10 MHz	Mode A	B (ANT 2)	1 0	ACC-ELD: 49 kbps	Transverse	Pass	-51.43	223	600	26	26	148	300	33 - 34

## 5G NR (VoNR) Test Results

Band / Mode	Channel and Frequency	Channel Bandwidth	SCS (kHz)	Power Mode	Port/ANT	RB Allocation	Codec and Bit rate (kbps)	Orientation	Frequency Response	Ambient Noise dB(A/m)	Primary Group Contiguous Pts	Secondary Group Contiguous Pts	Secondary Group Max Longitudinal	Secondary Group Max Transverse	Primary Group Contiguous Pts Margin	Secondary Group Contiguous Pts Margin	Plot Page #
5G NR Band n12 DFT-s TT/2 BPSK	141500 707.5 MHz	15 MHz	15	Mode A	B (ANT 2)	1 1	ACC-ELD: 49 kbps	Transverse	Pass	-51.52	249	609	26	26	174	309	35 - 36
5G NR Band n25 DFT-s TT/2 BPSK	376500 1882.5 MHz	40 MHz	15	Mode A	B (ANT 2)	1 1	ACC-ELD: 49 kbps	Transverse	Pass	-51.52	247	605	26	26	172	305	37 - 38
5G NR Band n30 DFT-s TT/2 BPSK	462000 2310 MHz	10 MHz	15	Mode A	B (ANT 2)	1 1	ACC-ELD: 49 kbps	Transverse	Pass	-51.52	249	603	26	26	174	303	39 - 40
5G NR Band n41 PC3 DFT-s QPSK	518598 2592.99 MHz	100 MHz	30	Mode A	B (ANT 2)	1 1	ACC-ELD: 49 kbps	Transverse	Pass	-51.53	156	509	22	26	81	209	41 - 42
5G NR Band n41 PC2 DFT-s QPSK	518598 2592.99 MHz	100 MHz	30	Mode A	B (ANT 2)	1 1	ACC-ELD: 49 kbps	Transverse	Pass	-51.53	147	500	22	26	72	200	43 - 44
5G NR Band n77 PC3 DFT-s QPSK	656000 3840 MHz	100 MHz	30	Mode A	B (ANT 8)	1 1	ACC-ELD: 49 kbps	Transverse	Pass	-51.53	206	565	23	26	131	265	45 - 46
5G NR Band n77 PC2 DFT-s QPSK	656000 3840 MHz	100 MHz	30	Mode A	B (ANT 8)	1 1	ACC-ELD: 49 kbps	Transverse	Pass	-51.53	198	558	23	26	123	258	47 - 48

### Note(s):

A limited set of 5G NR (VoNR) bands were evaluated to confirm 5G NR (VoNR) compliance.

- At least one 5G NR (VoNR)-FDD LB, MB and HB were evaluated.
- At least one 5G NR (VoNR)-TDD HB and UHB were evaluated.

## WLAN (VoWiFi) Test Results

Band / Mode	Channel and Frequency	Power Mode	Port/ANT	Codec and Bit rate (kbps)	Modulation/ Data Rate	Orientation	Frequency Response	Ambient Noise dB(A/m)	Primary Group Contiguous Pts	Secondary Group Contiguous Pts	Secondary Group Max Longitudinal	Secondary Group Max Transverse	Primary Group Contiguous Pts Margin	Secondary Group Contiguous Pts Margin	Plot Page #
802.11b 20 MHz BW	6 2437 MHz	Power State 1 Head	ANT 2	EVS: 5.9 kbps	CKK 5.5 Mbps	Transverse	Pass	-51.54	197	511	26	26	122	211	49 - 50
802.11n HT20 20 MHz BW	36 5180 MHz	Power State 1 Head	ANT 6	EVS: 5.9 kbps	MCS0 6.5 Mbps	Transverse	Pass	-51.49	188	517	26	26	113	217	51 - 52
	52 5280 MHz	Power State 1 Head	ANT 6	EVS: 5.9 kbps	MCS0 6.5 Mbps	Transverse	Pass	-51.49	196	515	26	26	121	215	53 - 54
	100 5500 MHz	Power State 1 Head	ANT 6	EVS: 5.9 kbps	MCS0 6.5 Mbps	Transverse	Pass	-51.49	191	517	26	26	116	217	55 - 56
	149 5745 MHz	Power State 1 Head	ANT 6	EVS: 5.9 kbps	MCS0 6.5 Mbps	Transverse	Pass	-51.49	196	516	26	26	121	216	57 - 58
802.11ax HE20 20 MHz BW	5 5975 MHz	Power State 1 Head	ANT 6	EVS: 5.9 kbps	MCS0 6.5 Mbps	Transverse	Pass	-51.52	304	640	26	26	229	340	59 - 60
802.11be EHT20 20MHz BW	5 5975 MHz	Power State 1 Head	ANT 6	EVS: 5.9 kbps	MCS0 6.5 Mbps	Transverse	Pass	-51.52	319	647	26	26	244	347	61 - 62

### 10.1. Worst Case T-Coil Test Plot(s)

UL Verification Services Inc. SAR Lab 19

Date/Time: August 11, 2025 at 01:11

#### T-Coil Signal Test Report: 5G NR (DFT-s-OFDM, 1 RB, 100 MHz, QPSK, 30 kHz)

##### Device Under Test

Manufacturer	Model	Dimensions [mm]	Speaker Position [mm]
		146.2 x 71.8 x 7.5	144.3

##### Hardware Setup

Probe Name	Probe Calibration Date	DAE Name	DAE Calibration Date
AM1DV3 - 3165	March 04, 2025	DAE4ip Sn1881	February 17, 2025

##### Communication Systems

Band Name	Communication Systems Name	Channel	Frequency [MHz]
Band n41 PC2	5G NR (DFT-s-OFDM, 1 RB, 100 MHz, QPSK, 30 kHz)	518598	2592.99

##### Grid Settings

Extent X [mm]	Extent Y [mm]	Step X [mm]	Step Y [mm]	Distance [mm]
52.0	52.0	4.0	4.0	10.0

##### Results

Audio File	Measurement Duration [s]	Margin Upper Bound [dB]	Margin Lower Bound [dB]
48k_voice_300-3000_2s.wav	2.0	2.0	2.0

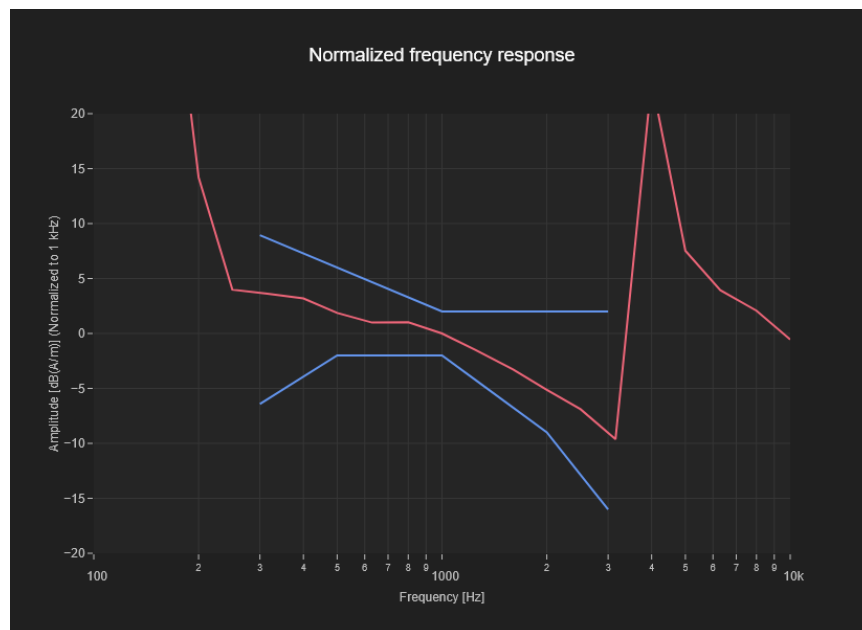

### T-Coil Coupling Mode Test Report:

#### Results

Primary Group Contiguous Point Count	Secondary Group Point Count	Secondary Group Max Longitudinal	Secondary Group Max Transverse
147	500	22	26

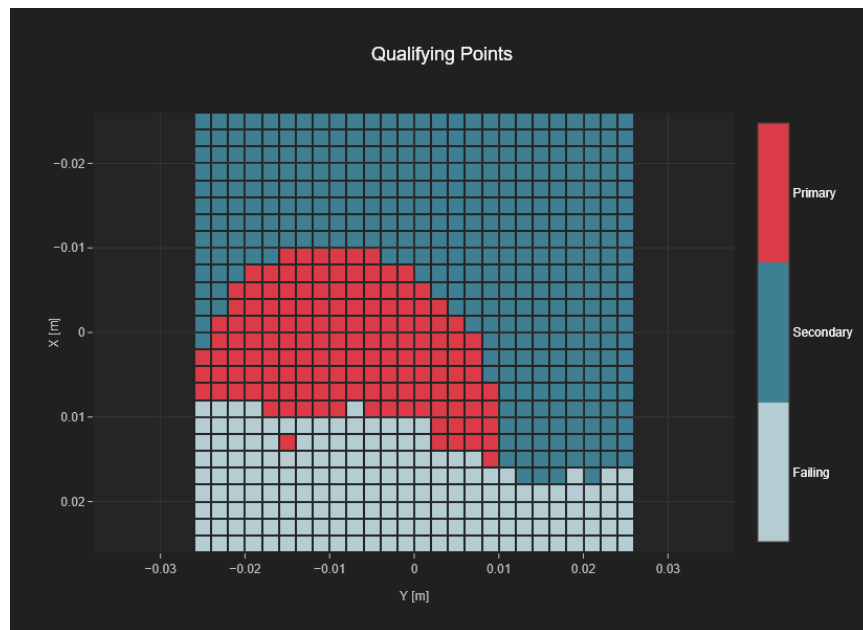



## **Appendix**

Refer to separate files for the following appendixes:

### **Appendix A: T-Coil Setup Photo**

### **Appendix B: T-Coil Test Plots**

### **Appendix C: T-Coil Probe Certificates**

**END OF REPORT**