

TEST REPORT

Report Number: 14982485-E31V4

Applicant : APPLE INC.
1 APPLE PARK WAY
CUPERTINO, CA 95014, U.S.A.

Model : A3286 (Parent Model)
A3287, A3288 (Variant Models)

Brand : APPLE

FCC ID : BCG-E8689A (Parent Model)
BCG-E8690A, BCG-8691A (Variant Models)

EUT Description : SMARTPHONE

Test Standard(s) : FCC 47 CFR PART 15 SUBPART E

Date Of Issue:

2024/08/23

Prepared by:

UL Verification Services Inc.
47173 Benicia Street
Fremont, CA 94538 U.S.A.
TEL: (510) 319-4000
FAX: (510) 661-0888





REPORT REVISION HISTORY

Rev.	Issue Date	Revisions	Revised By
V1	2024/08/13	Initial Review	Tony Li
V2	2024/08/20	Addressed TCB Feedback on Section 6.1, 6.2 and 10	Tony Li
V3	2024/08/23	Updated Setup Diagram to reflect Model	Tony Li
V4	2024/08/23	Updated Section 6.4 to include Companion Device	Tony Li

TABLE OF CONTENTS

REPORT REVISION HISTORY	2
TABLE OF CONTENTS	3
1. ATTESTATION OF TEST RESULTS	4
2. TEST RESULT SUMMARY	5
3. TEST METHODOLOGY	5
4. FACILITIES AND ACCREDITATION	5
5. DECISION RULES AND MEASUREMENT UNCERTAINTY	6
5.1. <i>METROLOGICAL TRACEABILITY</i>	<i>6</i>
5.2. <i>DECISION RULES.....</i>	<i>6</i>
5.3. <i>MEASUREMENT UNCERTAINTY.....</i>	<i>6</i>
6. EQUIPMENT UNDER TEST	7
6.1. <i>EUT DESCRIPTION</i>	<i>7</i>
6.1.1. <i>EUT DEVICE CLASS.....</i>	<i>7</i>
6.2. <i>DESCRIPTION OF AVAILABLE ANTENNAS AND CABLE LOSS.....</i>	<i>7</i>
6.3. <i>SOFTWARE AND FIRMWARE.....</i>	<i>7</i>
6.4. <i>DESCRIPTION OF TEST SETUP.....</i>	<i>8</i>
7. MEASUREMENT METHOD.....	9
8. TEST AND MEASUREMENT EQUIPMENT	10
9. VLP TPC.....	11
10. SETUP PHOTOS.....	13

1. ATTESTATION OF TEST RESULTS

Applicant Name and Address	APPLE INC. 1 APPLE PARK WAY CUPERTINO, CA 95014, U.S.A.		
Model	A3286 (Parent Model) A3287, A3288 (Variant Models)		
Brand	APPLE		
FCC ID	BCG-E8689A (Parent Model) BCG-E8690A, BCG-8691A (Variant Models)		
EUT Description	SMARTPHONE		
Serial Number	CYWYP2R745		
Sample Receipt Date	2024/07/31		
Date Tested	2024/08/08 to 2024/08/09		
Applicable Standards	CFR 47 Part 15 Subpart E		
Test Results	COMPLIES		
<p>UL Verification Services Inc. tested the above equipment in accordance with the requirements set forth in the above standards. The test results show that the equipment tested is capable of demonstrating compliance with the requirements as documented in this report.</p> <p>The results documented in this report apply only to the tested sample, under the conditions and modes of operation as described herein. It is the manufacturer's responsibility to assure that additional production units of this model are manufactured with identical electrical and mechanical components. All samples tested were in good operating condition throughout the entire test program. Measurement Uncertainties are published for informational purposes only and were not taken into account unless noted otherwise.</p> <p>This document may not be altered or revised in any way unless done so by UL Verification Services Inc. and all revisions are duly noted in the revisions section. Any alteration of this document not carried out by UL Verification Services Inc. will constitute fraud and shall nullify the document. This report must not be used by the client to claim product certification, approval, or endorsement by A2LA, NIST, any agency of the Federal Government, or any agency of the U.S. government.</p>			
Approved & Released By:		Prepared & Reviewed By:	
			
Francisco de Anda Staff Engineer UL Verification Services, Inc.		Tony Li Lead Test Engineer UL Verification Services, Inc.	

2. TEST RESULT SUMMARY

This report contains data provided by the customer which can impact the validity of results. UL Verification Services Inc. is only responsible for correctly integrating customer-provided data with measurements performed by UL Verification Services Inc.

Below is a list of the data provided by the customer:

1. Antenna gain and type (see section 6.2)
2. Cable loss (see section 6.2)

Requirement Description	Requirement Clause Number (FCC)	Result	Comment
Transmit Power Control Mechanism	§15.407 (d) (10)	Compliant	Very Low Power Device

3. TEST METHODOLOGY

The tests documented in this report were performed in accordance with:

- FCC CFR 47 Part 2
- FCC CFR 47 Part 15
- FCC KDB 662911 D01 v02r01
- FCC KDB 789033 D02 v02r01
- FCC KDB 987594 D01 General Requirements v02r02
- FCC KDB 987594 D02 EMC Measurement v02r01
- ANSI C63.10-2013

4. FACILITIES AND ACCREDITATION

UL Verification Services Inc. is accredited by A2LA, certification #0751.05, for all testing performed within the scope of this report. Testing was performed at the locations noted below.

	Address	ISED CABID	ISED Company Number	FCC Registration
<input type="checkbox"/>	Building 1: 47173 Benicia Street, Fremont, CA 94538, USA	US0104	2324A	550739
<input checked="" type="checkbox"/>	Building 2: 47266 Benicia Street, Fremont, CA 94538, USA			
<input type="checkbox"/>	Building 3: 843 Auburn Court, Fremont, CA 94538 USA			
<input type="checkbox"/>	Building 4: 47658 Kato Rd, Fremont, CA 94538 USA			
<input type="checkbox"/>	Building 5: 47670 Kato Rd, Fremont, CA 94538 USA			

5. DECISION RULES AND MEASUREMENT UNCERTAINTY

5.1. METROLOGICAL TRACEABILITY

All test and measuring equipment utilized to perform the tests documented in this report are calibrated on a regular basis, with a maximum time between calibrations of one year or the manufacturers' recommendation, whichever is less, and where applicable is traceable to recognized national standards.

5.2. DECISION RULES

The Decision Rule is based on Simple Acceptance in accordance with ISO Guide 98-4:2012 Clause 8.2. (Measurement uncertainty is not taken into account when stating conformity with a specified requirement.)

5.3. MEASUREMENT UNCERTAINTY

Where relevant, the following measurement uncertainty levels have been estimated for tests performed on the apparatus:

PARAMETER	U_{Lab}
Conducted Antenna Port Emission Measurement	1.940 dB
Power Spectral Density	2.466 dB
Radio Frequency (Spectrum Analyzer)	141.16 Hz

Uncertainty figures are valid to a confidence level of 95%.

6. EQUIPMENT UNDER TEST

6.1. EUT DESCRIPTION

The Apple iPhone is a smartphone with cellular GSM, GPRS, EGPRS, WCDMA, LTE, 5G NR1, IEEE 802.11a/b/g/n/ac/ax/be, Bluetooth (BT), Ultra-Wideband (UWB), Global Positioning System (GPS), Near-Field Communication (NFC), Narrow-Band (NB) UNII, 802.15.4, 802.15.4ab-Narrow Band (NB), WPT and Mobile Satellite Service (MSS) technologies. The rechargeable battery is not user accessible. This device is not user-serviceable and requires special tools to disassemble.

This report covers WiFi-7 requirements for Very Low Power device.

6.1.1. EUT DEVICE CLASS

Equipment class: (6VL)	U-NII Bands of Operation			
	5	6	7	8
Very Low Power TPC	<input checked="" type="checkbox"/>	<input type="checkbox"/>	<input checked="" type="checkbox"/>	<input type="checkbox"/>

6.2. DESCRIPTION OF AVAILABLE ANTENNAS AND CABLE LOSS

The antennas gain and type, cable loss as provided by the manufacturer' are as follows:

Antenna Type: IFA

Frequency Range (MHz)	Sub-band (MHz)	Antenna 6 (dBi)	Antenna 5 (dBi)	Uncorrelated Chains (dBi)	Correlated Chains (dBi)
UNII-5	Sub-band 1 (5955 - 6095) (Disabled)	1.3	-2.60	-0.23	2.58
	Sub-band 2 (6115 - 6255)	-0.70	-2.20	-1.39	1.59
	Sub-band 3 (6275 - 6415)	0.40	-2.40	-0.78	2.12
UNII-7	6535 - 6855	-0.50	-1.90	-1.14	1.84

Cable Loss		
Frequency Range (MHz)	Antenna 6 (dB)	Antenna 5 (dB)
6115 - 6415	3.20	2.98
6535 - 6855	3.20	2.98

The SMA cables were used for RF antenna port tests that had been offset to the test equipment during testing.

6.3. SOFTWARE AND FIRMWARE

The EUT firmware installed during testing was 10_1.

6.4. DESCRIPTION OF TEST SETUP

SUPPORT TEST EQUIPMENT						
Description	Manufacturer	Model	Serial Number	FCC ID/ DoC		
Laptop	Apple	Macbook Pro	C02GD2Y5ML7H	N/A		
Laptop AC/DC adapter	Liteon Technology	A1424	C4H71070862GN8RAR	DoC		
95 dB Programmable Attenuator, 1 MHz - 8 GHz	Mini-Circuits	RC4DAT-8G-95	12210030037	DoC		
Companion Device (Phone)	Apple	A3286	N/A	BCG-E8689A		
I/O CABLES (RF CONDUCTED TEST)						
Cable No.	Port	# of Identical Ports	Connector Type	Cable Type	Cable Length (m)	Remarks
1	SMA	1	SMA	Shielded	0.75	To spectrum Analyzer
3	USB-C	1	USB-C	Shielded	1.0	N/A
4	DC	1	AC	Shielded	2	From AC/DC Adapter to LT

TEST SETUP

The EUT setup is shown as below. Test software exercised the radio card.

Note, companion device is same device type and model as the EUT and is used to establish a peer-to-peer link.

ETUP DIAGRAM FOR CONDUCTED TESTS

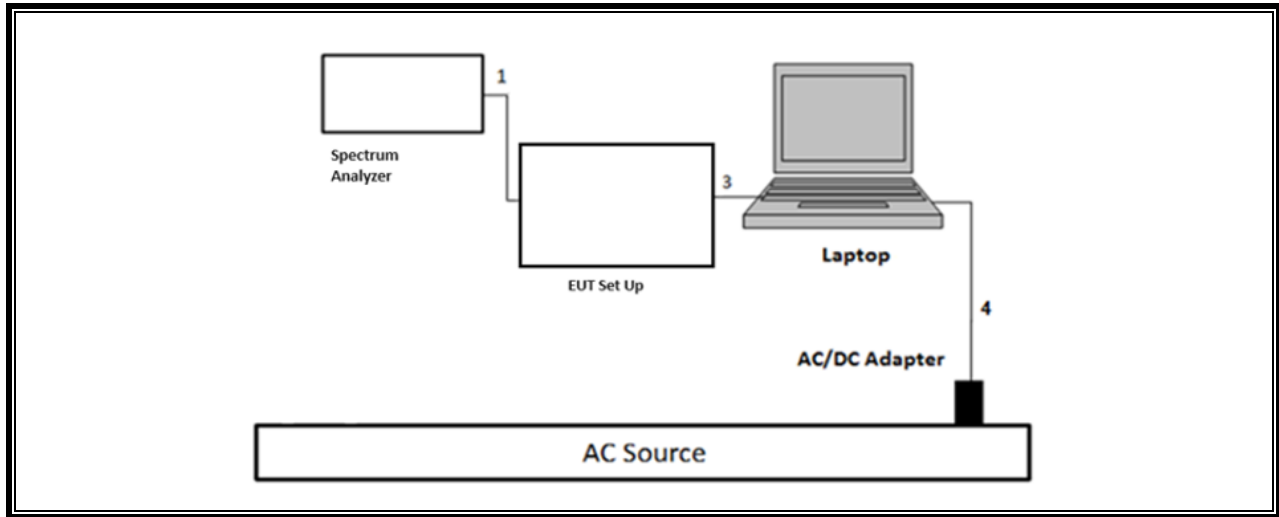

EUT SET UP

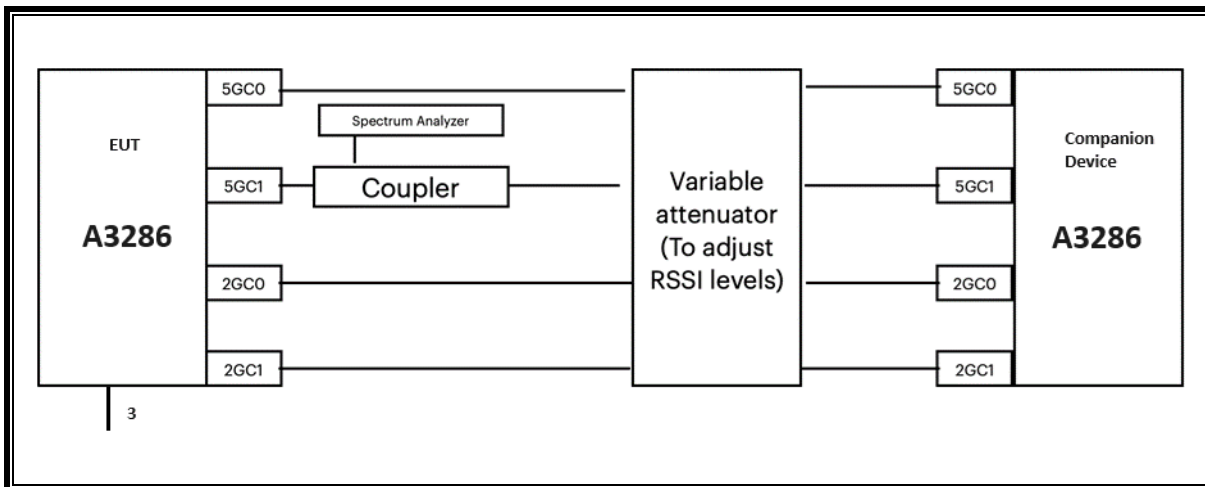

7. MEASUREMENT METHOD

Power Spectral Density (PSD): KDB 789033 D02 v02r01, Section F

8. TEST AND MEASUREMENT EQUIPMENT

The following test and measurement equipment was utilized for the tests documented in this report:

TEST EQUIPMENT LIST					
Description	Manufacturer	Model	ID Num	Cal Due	Last Cal
Spectrum Analyzer, PXA, 3Hz to 44GHz	Keysight Technologies Inc	N9030A	81188	2025/01/31	2024/01/26
Directional Coupler	KRYTAR	158016	N/A	Calibrated Before Testing	

UL AUTOMATION SOFTWARE			
Conducted Software	UL	UL EMC	2023.2.23

9. VLP TPC

LIMITS

FCC §15.407 (d) (10)

(10) Very low power devices operating in the 5.925-6.425 and 6.525-6.875 GHz bands shall employ a transmit power control (TPC) mechanism. A very low power device is required to have the capability to operate at least 6 dB below the maximum EIRP power spectral density (PSD) value of -5 dBm/MHz.

PROCEDURE

This test demonstrates the ability of the device to increase and decrease power by the required 6dB as the RSSI is decreased and increased.

1. Configure EUT and companion device for peer-to-peer communication (refer to section 6.4)
2. Set variable attenuator to 0dB (noise free spectral environment, high RSSI simulation)
3. Establish a link and start communication between EUT and companion device
4. Capture PSD spectrum analyzer trace (1)
5. Set variable attenuator to 25dB (noisy spectral environment, low RSSI simulation)
6. Capture PSD spectrum analyzer trace (2)
7. Compare the highest PSD from trace (1) to the highest PSD on trace (2) and determine the delta. For MIMO operations use the sum of the highest PSD from each individual antenna

SA Settings: 1MHz RBW/ 3MHz VBW

Span: 200MHz

Sweep: 1ms, trace averaging enabled for 100 sweeps with rms detector enabled.

Set up - Refer to Section 6.4

RESULTS

The purpose of this test is to verify the relative power drop as the RSSI is increased. These values do not include antenna gain or other corrections to show the eirp.

1TX/2TX	UNII-5 band	Antenna 1		Antenna 2		Antenna 1 + 2		Pass / Fail (Delta ≥ 6dB)
BW (MHz)	Frequency (MHz)	Trace 1 High RSSI PSD (dBm/MHz)	Trace 2 Low RSSI PSD (dBm/MHz)	Trace 1 High RSSI PSD (dBm/MHz)	Trace 2 Low RSSI PSD (dBm/MHz)	Trace 1 High RSSI PSD (dBm/MHz)	Trace 2 Low RSSI PSD (dBm/MHz)	
160	6185	-13.83	-7.24	-13.86	-7.82	-10.83	-4.51	6.32dB - Pass

VLP TPC POWER LEVEL REDUCTION

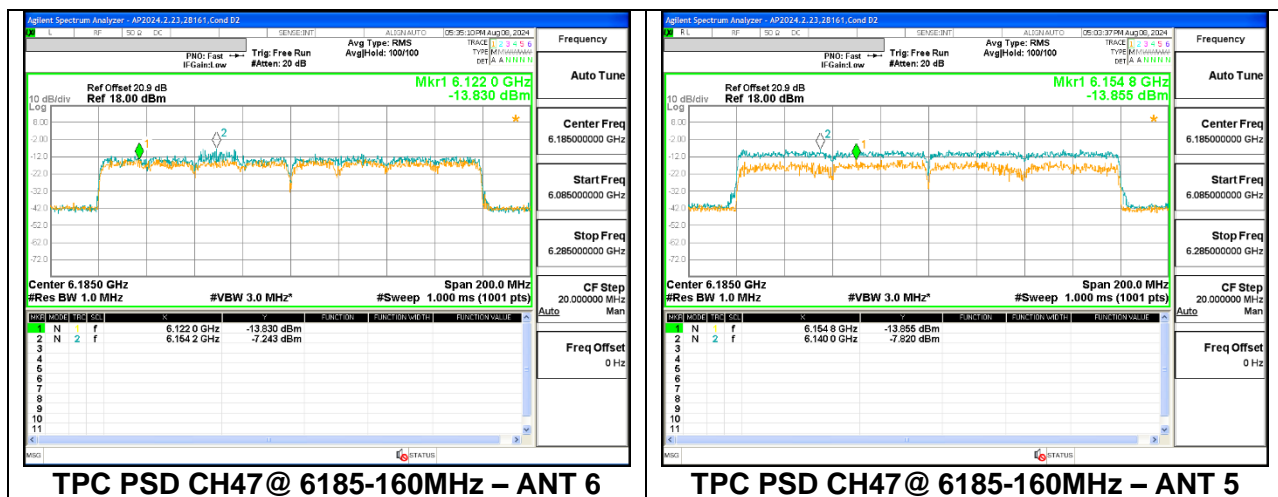

10. SETUP PHOTOS

Refer to 14982484-EP1V1 FCC IC Setup_Photo for set up photos.

END OF TEST REPORT