

Emission Test Report

Standard: FCC Part 15 Subpart C / IC RSS-210 (Class II Permissive Change)

Document Number : FCC 19-0276-0

Model Number: AR5BMB-44

measured with IBM ThinkPad G40 Series

FCC ID: ANO20040600BTL

IC: 349E-AR5BMB44

August 13, 2004

Prepared :
EMC R&D Staff Engineer

Takeshi Asano

Signature: 

IBM Japan, Ltd.
EMC Engineering
LAB-S59

1623-14, Shimotsuruma,
Yamato-shi Kanagawa-ken 242, Japan
Phone: +81-46-215-4779
Fax: +81-46-273-7420
E-Mail: asano@jp.ibm.com

Reviewed and Checked :
EMC Advisory R&D Engineer

Toshiya Murota

Signature: 

IBM Japan, Ltd.
EMC Engineering
LAB-S59

1623-14, Shimotsuruma,
Yamato-shi Kanagawa-ken 242, Japan
Phone: +81-46-215-6574
Fax: +81-46-273-7420
E-Mail: murota@jp.ibm.com

Approved :
Manager, EMC Engineering
/ NVLAP signatory

Akihisa Sakurai

Signature: 

IBM Japan, Ltd.
EMC Engineering
LAB-S59

1623-14, Shimotsuruma,
Yamato-shi Kanagawa-ken 242, Japan
Phone: +81-46-215-2613
Fax: +81-46-273-7420
E-Mail: akihisa@jp.ibm.com

MEASUREMENT / TECHNICAL REPORT – Part 15 Subpart C (Intentional Radiator)

Model: AR5BMB-44 (802.11a/b/g Wireless LAN Adapter)
with
IBM ThinkPad G40 Series
(Machine Type: 2384, 2387, 2388, 2389, 2881, 2882, 2886)

FCC ID : ANO20040600BTL

August 13, 2004

This report concerns: (check one) Original Grant _____ Class I change _____ Class II change <input checked="" type="checkbox"/> _____
Equipment type: <u>Wireless LAN device</u>
This report shall not be reproduced except in full, without the written permission of this test lab.
The measurement results contained in this report relate only to the item which was tested.
Measurement procedure used is ANSI C63.4-2000 unless otherwise specified.
Other test procedure: _____
The FCC has issued provisional acceptance of this test laboratory for Declaration of Conformity testing per letter dated 1997.
APPLICANT ANTI-DRUG ABUSE CERTIFICATION: By checking yes, the applicant certifies that, in the case of an individual applicant, he or she is not subject to a denial of federal benefits, that includes FCC benefits, pursuant to Section 5301 of the Anti-Drug Abuse of 1988, 21 U.S.C. 853(a), or, in the case of a non-individual applicant (e.g. corporation, partnership or other unincorporated association), no party to the application is subject to a denial of federal benefits, that includes FCC benefits, pursuant to that section. For the definition of a “party” for these purposes, see 47 CFR 1.2002(b). <p style="text-align: center;"><input checked="" type="radio"/> Yes or No</p>
“Report shall not be reproduced except in full, without the written approval of the laboratory” “the report must not be used by the client to claim product endorsement by NVLAP or any agency of the US government”
Prepared by: Takeshi Asano <p style="text-align: right;"> IBM Japan Corporation, Yamato EMC Engineering LAB-S59, 1623-14, Shimotsuruma, Yamato-shi Kanagawa-ken 242-8502, Japan Tel: +81-46-215-4779 Fax: +81-46-273-7420 </p>

- Index -

- A. General Information..... 5**
 - A.1 Test Methodology..... 5
 - A.2 Test Facility / NVLAP Accreditation..... 5
 - A.3 EUT details 5
- B. Summary of Test Results..... 6**
- C. Operation Mode of EUT 7**
- D. Justification 7**
- E. Test Instruments 8**
- F. Measurement Uncertainty..... 9**
- G. Temperature and Humidity 9**
- H. Related Submittal(s)/Grant(s)/Notes 9**
- 1. Bandwidth at 6 dB below..... 10**
 - 1.1 Test Procedure..... 10
 - 1.2 Test Instruments and Measurement Setup..... 10
 - 1.3 Measurement Results 10
 - 1.4 Trace Data of 6dB bandwidth..... 12
- 2. Occupied Bandwidth (20 dB Bandwidth) 15**
 - 2.1 Test Procedure..... 15
 - 2.2 Test Instruments and Measurement Setup..... 15
 - 2.3 Measurement Results 15
 - 2.4 Trace Data of Occupied Bandwidth 17
- 3. Conducted Peak Transmit Output Power..... 20**
 - 3.1 Test Procedure..... 20
 - 3.2 Test Instruments and Measurement Setup..... 20
 - 3.3 Measurement Results 20
 - 3.4 Trace Data of Conducted Peak Output Power 21
- 4. Out of Band Emissions (Conducted Spurious)..... 24**
 - 4.1 Test Procedure..... 24
 - 4.2 Test Instruments and Measurement Setup..... 24
 - 4.3 Measurement Results 24
 - 4.4 Trace Data of Out of Band Emissions 26
- 5. Peak Power Spectral Density 35**
 - 5.1 Test Procedure..... 35
 - 5.2 Test Instruments and Measurement Setup..... 35
 - 5.3 Measurement Results 35
 - 5.4 Trace Data of Peak Power Spectral Density 36
- 6. AC Wireline Conducted Emissions (150KHz – 30MHz) 39**
 - 6.1 Test Procedure..... 39
 - 6.2 Test Instruments and Measurement Setup..... 39
 - 6.3 Powerline Voltage Calculation..... 40
 - 6.4 Measurement Results 41

- 7. Restricted Bands Radiation (30MHz – 1GHz) 45**
 - 7.1 Test Procedure..... 45
 - 7.2 Test Instruments and Measurement Setup..... 45
 - 7.3 Field Strength Calculation 47
 - 7.4 Measurement Results 48

- 8. Restricted Bands Radiatio (1GHz – 40GHz) 51**
 - 8.1 Test Procedure..... 51
 - 8.2 Test Instruments and Measurement Setup..... 51
 - 8.3 Field Strength Calculation 53
 - 8.4 Measurement Results 54
 - 8.5 Measurement plots of adjacent restricted band..... 59
 - 8.5.1 List of Measurement Results 59
 - 8.5.2 Bandedge Measurement Plots 60

A. General Information

APPLICANT : IBM Japan, Ltd.
TEST SITE : IBM Japan, Ltd., Yamato Semi-anechoic chamber #1
TEST SITE ADDRESS : 1623 – 14 Shimotsuruma, Yamato-shi, Kanagawa 242-8502 Japan
 Tel: +81-46-215-4779, Fax: +81-46-273-7420
REGULATION : FCC Part 15 Subpart C
 Industry Canada RSS-210 (Issue No.5)
MODEL NUMBER : AR5BMB-44
 (Advertising Name) (IBM 11a/b/g Wireless LAN Mini PCI Adapter II)
FCC ID : ANO20040600BTL
IC Certification Number : 349E-AR5BMB44
SERIAL NUMBER : 00S0SIT004
PHYSICAL CONDITION : Preproduction
KIND OF EQUIPMENT : Personal computer with a IEEE802.11a, 11b & 11g Wireless LAN
 Mini-PCI Combo Card ([Composite application](#))
TESTED DATE : July 8, 12, 13, 14, 15, 22, 23, 26 and 29, 2004

A.1 Test Methodology

Both conducted and radiated testing were performed according to the procedures in ANSI C63.4-2000. Radiated testing was performed at an antenna to EUT distance of 3 meters.

A.2 Test Facility / NVLAP Accreditation

The semi-anechoic chamber #1 used to correct the data are located in Yamato Laboratory, IBM Japan.

- This facility has been fully described in a report dated September 1998, submitted to the FCC office, and accepted in a letter, dated Nov. 2, 1998(31040/SIT).
- IBM Yamato EMC Engineering is recognized under the National Voluntary Laboratory Accreditation Program for satisfactory compliance with Criteria established in Title 15, Part 285 Code of Federal Regulations.([NVLAP Lab code: 200198-0](#))
- These facilities are accepted by [Industry Canada](#) as number [IC 4221](#) for chamber #1 (expiry date: January 25, 2005), and as number [IC 4221-1](#) for chamber #2 (expiry date: February 16, 2007).

A.3 EUT details

Table A EUT details

Model and S/N	FCC ID IC Certification Number	Description
AR5BMB-44 (s/n 00S0SIT004)	FCC ID: ANO20040600BTL IC: 349E-AR5BMB44	Applying modular transmitter Built_in type IEEE802.11a/b/g Wireless LAN Mini-PCI card without antenna
ThinkPad G40 Series M/T 2881-4Ax (14") (s/n SIT34007) M/T 2881-4Fx (15") (s/n SIT34028)	N/A	Host equipment IBM Notebook PC with built_in antenna CPU: Intel® Desktop Pentium® Celeron, 2.66GHz
P/N 02K7085	N/A	Universal AC adapter 120W, Unshielded power cord

B. Summary of Test Results

Table-B presents the list of the measurement items for DTS (Digital Transmissions System) devices under FCC Part 15 Subpart C and Industry Canada RSS-210.

The section numbers of upper portion are showing FCC number, and the other (lower) ones are for IC.

Table-B List of the measurements

Section(s)	Test Items : Transmit mode (TX):		Condition	Result
15.247(a)(2) 6.2.2(o) *1	Bandwidth at 6 dB below	At least 500kHz. (*1: RSS-210 Issue5: Amendment)	Conducted	Pass
15.215(c) 5.9.1	Occupied BW (Bandwidth at 20 dB below)	20 dB bandwidth of the emission to be within the allocation band.		Pass
15.247(c) 6.2.2(o)(e1)	Out of Band Emissions	The radiated emission in any 100kHz of outband shall be at least 20dB below the highest inband spectral density.		Pass
15.247(b)(3) 6.2.2(o)(b)	Conducted Peak Transmit Output Power	Shall not exceed 1.0 W.		Pass
15.247(d) 6.2.2(o)(b)	Transmitter power spectral Density	Shall not be greater than 8 dBm in any 3kHz band.		Pass
15.207 6.2.2(o)(e3) / 6.6	AC Wireline Conducted Emissions 150kHz – 30MHz	Class B: Freq.(MHz) QP(dBμV) Ave.(dBμV) 0.15 - 0.5 66 - 56 56 - 46 0.5 - 5 56 46 5 - 30 60 50		Pass
15.205 / 209 6.2.1 / 6.2.2(o)(e3) / 6.3	General Field Strength Limits (Restricted Bands and Radiated Emission Limits)	Shall not exceed the limits specified in FCC 15.209 or RSS-210 Table3.	Radiated (30MHz-1GHz)	Pass
			Radiated (1– 25GHz)	Pass

Test Items : Receive mode (RX):				
15.207 6.2.2(o)(e3) / 7.4	AC Wireline Conducted Emissions 150kHz – 30MHz	Class B: Freq.(MHz) QP(dBμV) Ave.(dBμV) 0.15 - 0.5 66 - 56 56 - 46 0.5 - 5 56 46 5 - 30 60 50	Conducted	Pass
15.205 / 209 6.2.1 / 6.2.2(o)(e3) / 7.3	General Field Strength Limits (Restricted Bands and Radiated Emission Limits)	Shall not exceed the limits specified in FCC 15.209 or RSS-210 Table3.	Radiated (30MHz -1GHz)	Pass
			Radiated (1– 25GHz)	Pass

Other requirements			Result
15.247(b)(4)(i) -	Antenna gain	Peak gain of the device : 0.87 dBi in 2.4GHz band, and 3.15 dBi in 5.8GHz band.	N/A
- 5.2	Supply Voltage	Main power source: Universal AC adapter 120W Mini-PCI PC bus to applying card : DC 3.3V ± 0.3V	N/A
15.203 6.2.2(o)(e2)	Unique antenna connector	The device employs an unique electronic connector so called Electronic Handshake . Refer to “Confidential_e-Handshake” exhibit.	complies

C. Operation Mode of EUT

- All tests were performed using the ‘‘Atheros Radio Test’’ program. This tool supports the continuous transmission mode for the testing purpose.
- The following frequencies were chosen for the measurements of each 2.4GHz or 5.8GHz band.
 - 2412MHz (lowest), 2437MHz(middle), and 2462MHz (highest) for 2.4GHz band
 - 5745MHz (lowest), 5785MHz(middle), and 5825MHz (highest) for 5.8GHz band
- As for the RF receiving test, the middle channels (2437MHz or 5785MHz) were selected representatively.

Table-C Transmission mode of EUT (The measurement plots are shown in shading.)

Note) The table shows the specification of **average** power for the applying device in ‘dBm’.

Operation Frequency [GHz]	Designed average output power (conducted) [dBm]											
	IEEE802.11b			IEEE802.11g								
	1/2M bps	5.5M bps	11M bps	6M bps	9M bps	12M bps	18M bps	24M bps	36M bps	48M bps	54M bps	
2.412 (Ch. 1)	17	17	17	14	14	14	14	14	14	14	14	
2.417 (Ch. 2)	18	18	18	17	17	17	17	17	17	15	14	
2.422 (Ch. 3)	18	18	18	18	18	18	18	18	17	15	14	
2.427 (Ch. 4)	18	18	18	18	18	18	18	18	17	15	14	
2.432 (Ch. 5)	18	18	18	18	18	18	18	18	17	15	14	
2.437 (Ch. 6)	18	18	18	18	18	18	18	18	17	15	14	
2.442 (Ch. 7)	18	18	18	18	18	18	18	18	17	15	14	
2.447 (Ch. 8)	18	18	18	18	18	18	18	18	17	15	14	
2.452 (Ch. 9)	18	18	18	18	18	18	18	18	17	15	14	
2.457 (Ch. 10)	18	18	18	17	17	17	17	17	17	15	14	
2.462 (Ch. 11)	17	17	17	14	14	14	14	14	14	14	14	
				IEEE802.11a								
5.745 (Ch.149)	N/A			16	16	16	16	16	15	14	11	
5.765 (Ch.153)				16	16	16	16	16	15	14	11	
5.785 (Ch.157)				16	16	16	16	16	15	14	11	
5.805 (Ch.161)				16	16	16	16	16	15	14	11	
5.825 (Ch.165)				16	16	16	16	16	15	14	11	

D. Justification

- The shading columns in the previous Table C show the transmission modes performed full testing.
- The EUT was investigated for both main (left) and auxiliary (right) antennas on each LCD 14 or 15 inch model. The worse case data taken in this report represents the measurement results of LCD 14 inch model with the auxiliary antenna for 2.4GHz band and the main antenna for 5.8GHz that have comparatively higher gain as shown by the Table-D below.

The actual highest emissions taken in this report in the Chapter 6 through 8 were found at 11Mbps for 2.4GHz DSSS and 6Mbps for both 2.4GHz/5.8GHz OFDM transmission mode. Refer to the Chapter 8.5 concerning the evaluation of the worst emission case.

Table-D Peak Antenna Gains of EUT

		14’’ model	15’’ model
2.4GHz band	Main Antenna gain	-0.25 dBi (peak)	0.18 dBi (peak)
	Auxiliary Antenna gain	0.87 dBi (peak)	0.52 dBi (peak)
5.8GHz band	Main Antenna gain	3.15 dBi (peak)	1.22 dBi (peak)
	Main Antenna gain	2.11 dBi (peak)	-0.01 dBi (peak)

E. Test Instruments

Table-E List of Measuring Instruments

Description	Model	Serial Number	Calibration Date	Calibration Interval
Computer	IBM 6868-30J	97-901X3	N/A	N/A
Computer	IBM 6589-13J	97-15613	N/A	N/A
Spectrum Analyzer (100Hz-1.5GHz)	HP 85680B	2601A02634	09/09/03	1 year
Spectrum Analyzer (100Hz-1.5GHz)	HP 85680B	3019A05156	08/14/03	1 year
Spectrum Analyzer (100Hz-1.5GHz)	HP 85680B	2841A04254	08/25/03	1 year
Spectrum Analyzer Display	HP 85662A	2542A12308	09/09/03	1 year
Spectrum Analyzer Display	HP 85662A	3026A19366	08/14/03	1 year
Spectrum Analyzer Display	HP 85662A	2816A16831	08/25/03	1 year
Quasi-Peak Adapter	HP 85650A	2043A00062	09/09/03	1 year
Quasi-Peak Adapter	HP 85650A	2811A01433	08/14/03	1 year
Quasi-Peak Adapter	HP 85650A	2811A01156	08/25/03	1 year
Amplifier (100KHz - 1.3GHz) - for 30-200MHz	MITEQ AM-3A	898433	04/23/04	1 year
- for 200-1000MHz	MITEQ AM-3A	898432	04/23/04	1 year
Amplifier (1GHz - 18GHz)	HP 8449B	3008A00582	06/01/04	1 year
Amplifier (18 – 40GHz)	Agilent 83051A	3950M00193	01/27/04	1 year
Spectrum Analyzer EMI Test Receiver	R&S ESI26	836119/003	05/10/04	1 year
Spectrum Analyzer	HP 8563E	3416A02248	08/21/03	1 year
Harmonic Mixer	Agilent 11970A	011269-001	07/19/03	1 year
Receiver (9kHz-30MHz)	R&S ESH3	891806/012	10/17/03	1 year
Receiver (20MHz-1.3GHz)	R&S ESVP	893202/018	02/10/04	1 year
Biconical Antenna (30-200MHz)	EMCO 3108	2536	04/23/04	1 year
Log-Periodic Antenna (200-1000MHz)	EMCO 3146	2849	04/23/04	1 year
Horn Antenna (1- 18GHz)	EMCO 3115	9903-5774	07/17/03	1 year
Horn Antenna (3.95- 5.85GHz)	EMCO 3160-5	1099	07/17/03	1 year
Horn Antenna (5.85- 8.20GHz)	EMCO 3160-6	9712-1044	07/17/03	1 year
Horn Antenna (8.20- 12.4GHz)	EMCO 3160-7	1156	07/17/03	1 year
Horn Antenna (12.4- 18GHz)	EMCO 3160-8	1143	07/17/03	1 year
Horn Antenna (18- 26.5GHz)	EMCO 3160-9	0004-1202	07/17/03	1 year
Horn Antenna (26.5- 40GHz)	EMCO 3160-10	1175	07/17/03	1 year
LISN	EMCO 3810/2NM	00022007	06/15/04	1 year
Switch/control unit	HP 3488A	2719A17226 2719A17228	N/A N/A	N/A N/A
Plotter	HP 7550A	2631A33619	N/A	N/A
Coaxialcables (1 – 18GHz): - Horn Ant <=> RF Amp. - RF Amp.<=>Spectrum Analyzer(<12GHz) - RF Amp.<=>Spectrum Analyzer(>12GHz)	Length: 6 m 16m 3m	- EM206SCO - GEM0101 - SF102-20166	03/25/04 03/25/04 04/08/04	1 year 1 year 1 year
Coaxialcables (18 – 40GHz): - Horn Ant <=> RF Amp. - RF Amp.<=>Spectrum Analyzer	3m 1m	- SF102-20167 - SF102-21105	04/08/04 04/08/04	1 year 1 year

N-Coax cables:				
- Bi-coni Ant <=> 10m Cable	9 m	- EM103L01	04/23/04	1 year
- 10m Cable <=> Shield Panel	10 m	- EM103L02	04/23/04	1 year
- Shield Panel <=> RF Amp	7 m	- EM103L03	04/23/04	1 year
- RF Amp <=> Power Splitter	0.5m	- EM103L04	04/23/04	1 year
- Log-peri Ant <=> 10m Cable	9 m	- EM103H01	04/23/04	1 year
- 10m Cable <=> Shield Panel	10 m	- EM103H02	04/23/04	1 year
- Shield Panel <=> RF Amp	7 m	- EM103H03	04/23/04	1 year
- RF Amp <=> Power Splitter	0.5m	- EM103H04	04/23/04	1 year
Coax cables:				
- Lisn-L <=> SW/Con.unit (SW100)	4 m	- EMIC-L	04/23/04	1 year
- Lisn-N <=> SW/Con.unit (SW101)	4 m	- EMIC-N	04/23/04	1 year
- SW/Con.unit <=> RCVR (Input)	1 m	- EMIC-R	04/23/04	1 year
- SW/Con.unit<=> Spe Ana.(Signal In)	1 m	- EMIC-S	04/23/04	1 year
- Power Splitter <=> SW/Con.unit (SW110)	1 m	- EM103L05	04/23/04	1 year
- Power Splitter <=> SW/Con.unit (SW300)	1 m	- EM103L06	04/23/04	1 year
- Power Splitter <=> SW/Con.unit (SW100)	1 m	- EM103H05	04/23/04	1 year
- Power Splitter <=> SW/Con.unit (SW301)	1 m	- EM103H06	04/23/04	1 year
- SW/Con.unit <=> Receiver (Input)	2 m	- EM1RCV	04/23/04	1 year
- SW/Con.unit <=> Spe Ana.(Signal In) for 30- 200MHz	2 m	- EM1SPL	04/23/04	1 year
- SW/Con.unit <=> Spe Ana.(Signal In) for 200-1000MHz	2 m	- EM1SPH	04/23/04	1 year

Notes.

- The above equipment calibration is traceable to National standards.
- HP: Hewlett Packard, R&S: Rohde & Schwarz

F. Measurement Uncertainty

Uncertainties of the both, the Yamato EMI radiated test facilities (EMI chambers, #1 and #2) and the Yamato EMI conducted test facility are derived with the NIS 81 " Treatment of uncertainty in EMC measurements" 1994.

Estimated site uncertainty values are as follows.

- EMI chamber #1 : 4.39dB
- EMI chamber #2 : 4.40dB
- EMI conducted measurement system : 2.4dB

Detail should be referred to "Treatment of Uncertainty, Calculations and Policy" report, document number TCR 10-0015.

G. Temperature and Humidity

The temperature is controlled within range of 17° to 28°
 The relative humidity is controlled within range of 40% to 70%.

H. Related Submittal(s)/Grant(s)/Notes

During the applying modular device stops RF transmission, the host unit with full peripheral devices including the applying modular device is classified as an unintentional radiator, Digital Device under the FCC Part 15 Subpart B or the Industry Canada Class B Emission Compliance (ICES-003), and subject to DoC.

1. Bandwidth at 6 dB below

[FCC 15.247(a)(2), RSS-210 6.2.2(o)/ Issue 5: Amendment]

1.1 Test Procedure

The bandwidth at 6 dB down from the highest inband spectral density was measured with a spectrum analyzer connected to the antenna terminal, while EUT was operating in transmission mode at the appropriate center frequency.

The spectrum analyzer was set to :

RBW=100kHz, VBW=100kHz*1, Span=30MHz, Sweep = suitable duration based on the EUT specification

*1: To be adjusted accordingly based on the spectrum stability

1.2 Test Instruments and Measurement Setup

Table 1-1 : 6 dB Bandwidth Test Instruments

Description	Model	Serial Number
Spectrum Analyzer EMI Test Receiver	R&S ESI26	836119/003
Coax cables: - Spectrum Analyzer <=> EUT	Length : 110 cm Loss : 1.3 dB	

Notes: - R&S: Rohde & Schwarz

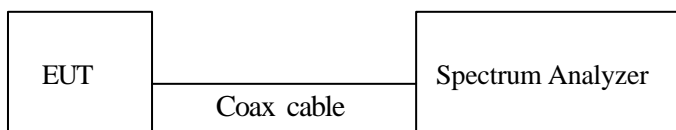

Figure 1: Measurement setup for 6dB bandwidth test

1.3 Measurement Results

Test Date: July 8 and 12, 2004

1.3.1 2.4GHz band DSSS mode

Table 1-2-1. 6dB bandwidth, 2.4GHz band DSSS mode, TX mode 1Mbps

Center Frequency (MHz)	Trace number	Lower frequency (MHz)	Upper frequency (MHz)	Bandwidth at 6 dB below (MHz)	Limit (MHz)
2412 (ch. 1)	omitted	2405.90	2418.10	12.20	> 0.5
2437 (ch. 6)	omitted	2430.90	2443.10	12.20	
2462 (ch. 11)	omitted	2455.42	2467.14	11.72	

Table 1-2-2. 6dB bandwidth, 2.4GHz band DSSS mode, TX mode 11Mbps

Center Frequency (MHz)	Trace number	Lower frequency (MHz)	Upper frequency (MHz)	Bandwidth at 6 dB below (MHz)	Limit (MHz)
2412 (ch. 1)	omitted	2406.08	2417.50	11.42	> 0.5
2437 (ch. 6)	Plot 1-1	2431.08	2442.50	11.42	
2462 (ch. 11)	omitted	2455.78	2467.38	11.60	

1.3.2 2.4GHz band OFDM mode

Table 1-2-3. 6dB bandwidth, 2.4GHz band OFDM mode, TX mode 6Mbps

Center Frequency (MHz)	Trace number	Lower frequency (MHz)	Upper frequency (MHz)	Bandwidth at 6 dB below (MHz)	Limit (MHz)
2412 (ch. 1)	omitted	2403.73	2420.27	16.54	> 0.5
2437 (ch. 6)	omitted	2428.73	2445.27	16.54	
2462 (ch. 11)	Plot 1-2	2453.67	2469.97	16.30	

Table 1-2-4. 6dB bandwidth, 2.4GHz band OFDM mode, TX mode 18Mbps

Center Frequency (MHz)	Trace number	Lower frequency (MHz)	Upper frequency (MHz)	Bandwidth at 6 dB below (MHz)	Limit (MHz)
2412 (ch. 1)	omitted	2403.73	2420.33	16.60	> 0.5
2437 (ch. 6)	omitted	2428.73	2445.33	16.60	
2462 (ch. 11)	omitted	2453.67	2470.21	16.54	

Table 1-2-5. 6dB bandwidth, 2.4GHz band OFDM mode, TX mode 54Mbps

Center Frequency (MHz)	Trace number	Lower frequency (MHz)	Upper frequency (MHz)	Bandwidth at 6 dB below (MHz)	Limit (MHz)
2412 (ch. 1)	omitted	2403.67	2420.33	16.66	> 0.5
2437 (ch. 6)	omitted	2428.67	2445.33	16.66	
2462 (ch. 11)	omitted	2453.67	2470.27	16.60	

1.3.3 5.8GHz band OFDM mode

Table 1-2-6. 6dB bandwidth, 5.8GHz band OFDM mode, TX mode 6Mbps

Center Frequency (MHz)	Trace number	Lower frequency (MHz)	Upper frequency (MHz)	Bandwidth at 6 dB below (MHz)	Limit (MHz)
5745 (ch. 149)	omitted	5736.73	5753.21	16.48	> 0.5
5785 (ch. 157)	omitted	5776.67	5793.21	16.54	
5825 (ch. 165)	Plot 1-3	5816.73	5833.21	16.48	

Table 1-2-7. 6dB bandwidth, 5.8GHz band OFDM mode, TX mode 18Mbps

Center Frequency (MHz)	Trace number	Lower frequency (MHz)	Upper frequency (MHz)	Bandwidth at 6 dB below (MHz)	Limit (MHz)
5745 (ch. 149)	omitted	5736.67	5753.27	16.60	> 0.5
5785 (ch. 157)	omitted	5776.67	5793.27	16.60	
5825 (ch. 165)	omitted	5816.67	5833.27	16.60	

Table 1-2-8. 6dB bandwidth, 5.8GHz band OFDM mode, TX mode 54Mbps

Center Frequency (MHz)	Trace number	Lower frequency (MHz)	Upper frequency (MHz)	Bandwidth at 6 dB below (MHz)	Limit (MHz)
5745 (ch. 149)	omitted	5736.67	5753.33	16.66	> 0.5
5785 (ch. 157)	omitted	5776.67	5793.33	16.66	
5825 (ch. 165)	omitted	5816.67	5833.33	16.66	

1.4 Trace Data of 6dB bandwidth

The plots are comparatively worse measurement cases of each transmission mode in the previous Table 1-2-1 through Table 1-2-8.

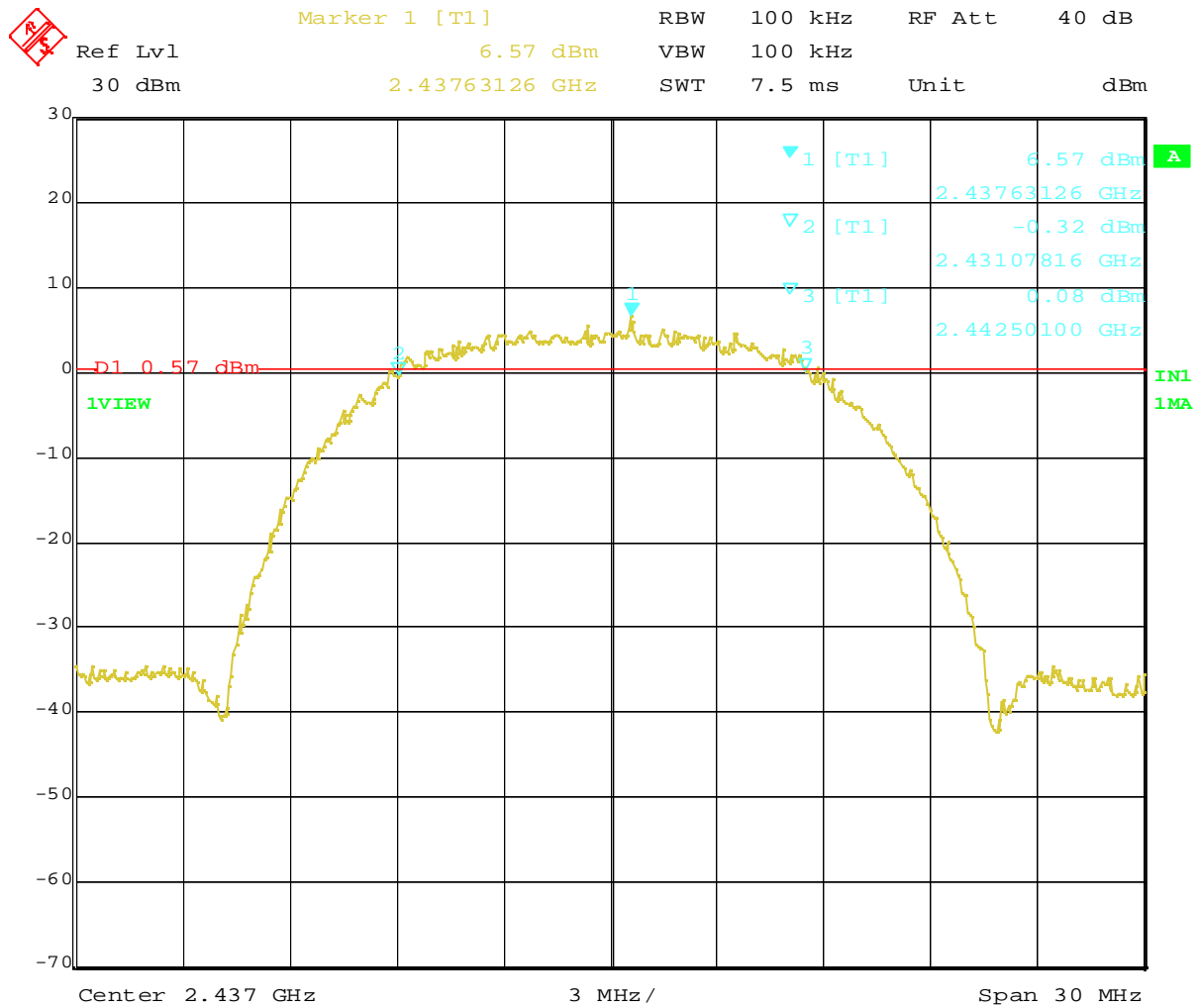

Date: 8.JUL.2004 19:28:19

Plot 1-1. 6dB BW at 2437MHz (DSSS, 11Mbps)

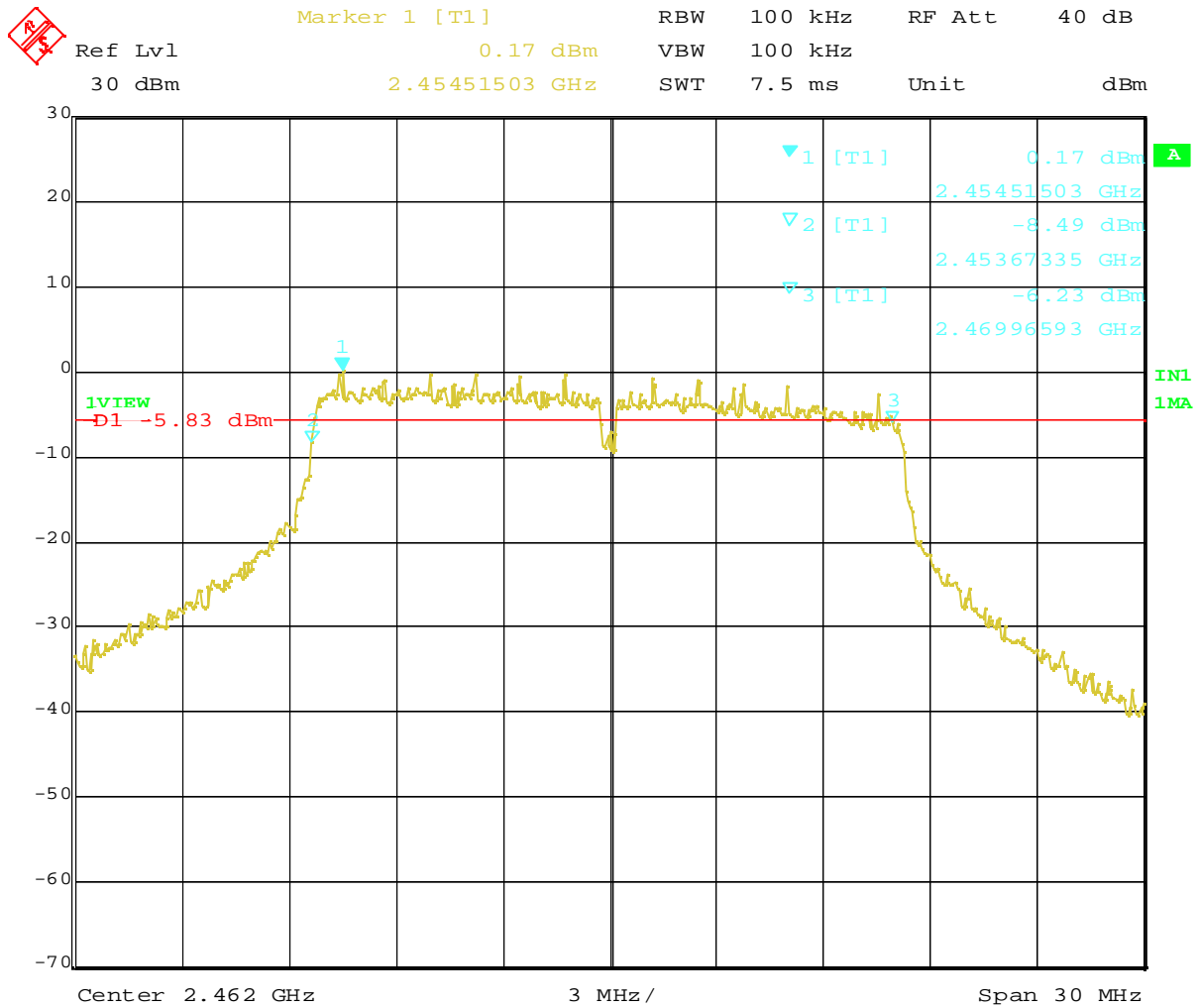

Date: 8.JUL.2004 20:22:30

Plot 1-2. 6dB BW at 2462MHz (OFDM, 6Mbps)

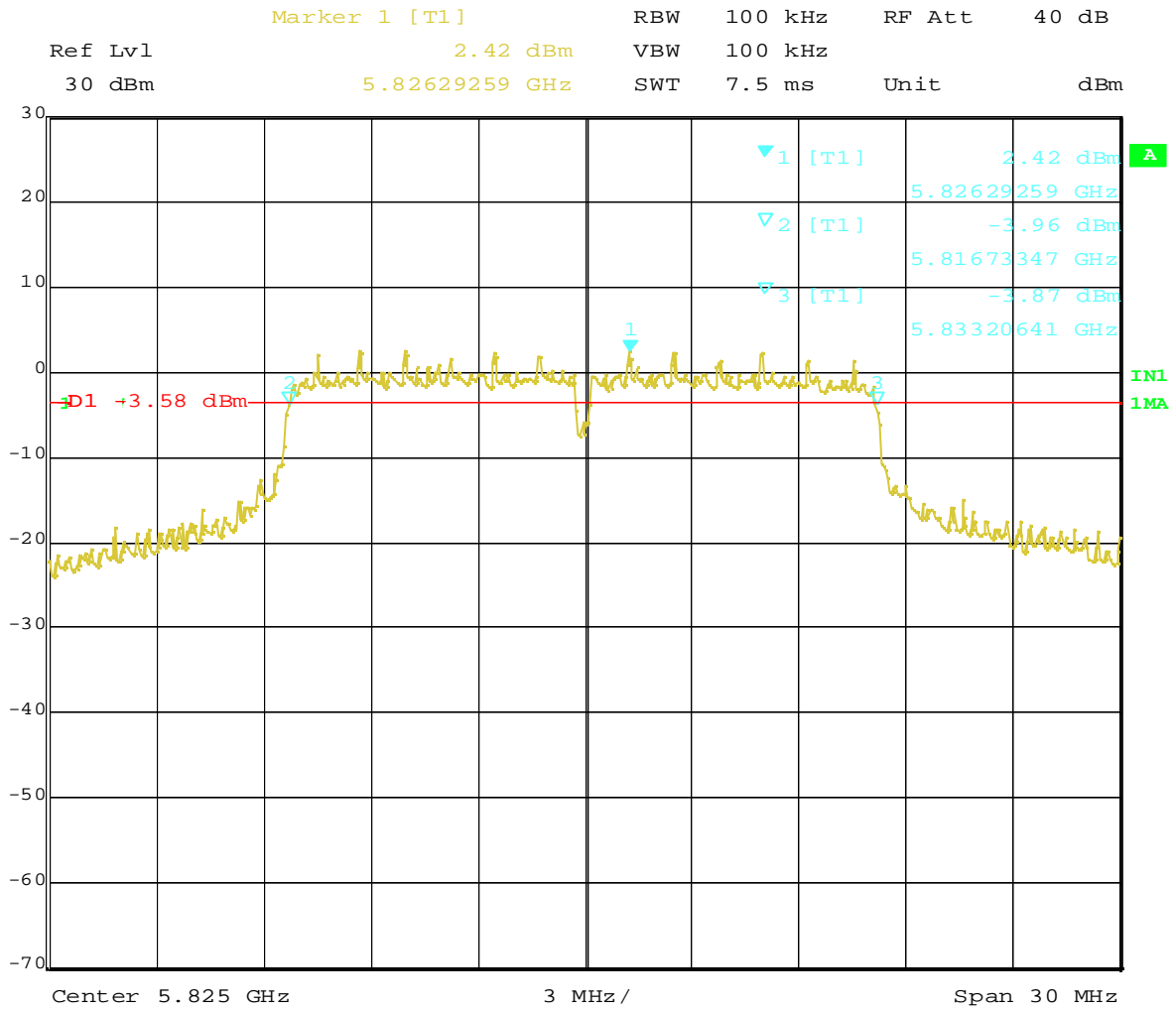

Date: 12.JUL.2004 20:47:14

Plot 1-3. 6dB BW at 5825MHz (OFDM, 6Mbps)

2. Occupied Bandwidth (20 dB Bandwidth) [FCC 15.215(c), RSS-210 5.9.1]

2.1 Test Procedure

The bandwidth at 20 dB down from the highest inband spectral density was measured with a spectrum analyzer connected to the antenna terminal, while EUT was operating in transmission mode at the appropriate center frequency.

The spectrum analyzer was set to:

RBW=100kHz, VBW=100kHz*1, Span=50MHz, Sweep = suitable duration based on the EUT specification

*1: To be adjusted accordingly based on the spectrum stability

2.2 Test Instruments and Measurement Setup

Same as the Chapter 1 (Table 1-1 & Figure 1).

2.3 Measurement Results

Test Date: July 8 and 12, 2004

2.3.1 2.4GHz band DSSS mode

Table 2-1. Occupied bandwidth, 2.4GHz band DSSS mode, TX 1Mbps

Center Frequency (MHz)	Trace number	Lower frequency (MHz)	Upper frequency (MHz)	Bandwidth at 20 dB below (MHz)
2412 (ch. 1)	omitted	2403.35	2420.69	17.34
2437 (ch. 6)	omitted	2427.83	2445.64	17.81
2462 (ch. 11)	omitted	2452.83	2470.69	17.86

Table 2-2. Occupied bandwidth, 2.4GHz band DSSS mode, TX 11Mbps

Center Frequency (MHz)	Trace number	Lower frequency (MHz)	Upper frequency (MHz)	Bandwidth at 20 dB below (MHz)
2412 (ch. 1)	Plot 2-1	2403.15	2420.89	17.74
2437 (ch. 6)	omitted	2428.13	2445.84	17.71
2462 (ch. 11)	omitted	2453.03	2470.69	17.66

2.3.2 2.4GHz band OFDM mode

Table 2-3. Occupied bandwidth, 2.4GHz band OFDM mode, TX 6Mbps

Center Frequency (MHz)	Trace number	Lower frequency (MHz)	Upper frequency (MHz)	Bandwidth at 20 dB below (MHz)
2412 (ch. 1)	Plot 2-2	2402.63	2421.37	18.74
2437 (ch. 6)	omitted	2427.63	2446.22	18.59
2462 (ch. 11)	omitted	2452.63	2470.87	18.24

Table 2-4. Occupied bandwidth, 2.4GHz band OFDM mode, TX 18Mbps

Center Frequency (MHz)	Trace number	Lower frequency (MHz)	Upper frequency (MHz)	Bandwidth at 20 dB below (MHz)
2412 (ch. 1)	omitted	2402.93	2421.07	18.14
2437 (ch. 6)	omitted	2427.73	2446.12	18.39
2462 (ch. 11)	omitted	2452.53	2470.77	18.24

Table 2-5. Occupied bandwidth, 2.4GHz band OFDM mode, TX 54Mbps

Center Frequency (MHz)	Trace number	Lower frequency (MHz)	Upper frequency (MHz)	Bandwidth at 20 dB below (MHz)
2412 (ch. 1)	omitted	2402.83	2421.47	18.64
2437 (ch. 6)	omitted	2427.63	2446.32	18.69
2462 (ch. 11)	omitted	2452.53	2470.87	18.34

2.3.3 5.8GHz band OFDM mode

Table 2-6. Occupied bandwidth, 5.8GHz band OFDM mode, TX 6Mbps

Center Frequency (MHz)	Trace number	Lower frequency (MHz)	Upper frequency (MHz)	Bandwidth at 20 dB below (MHz)
5745 (ch. 149)	Plot 2-3	5735.25	5755.19	19.94
5785 (ch. 157)	omitted	5775.23	5796.37	21.14
5825 (ch. 165)	omitted	5815.13	5836.37	21.24

Table 2-7. Occupied bandwidth, 5.8GHz band OFDM mode, TX 18Mbps

Center Frequency (MHz)	Trace number	Lower frequency (MHz)	Upper frequency (MHz)	Bandwidth at 20 dB below (MHz)
5745 (ch. 149)	omitted	5735.25	5754.79	19.54
5785 (ch. 157)	omitted	5774.43	5795.07	20.64
5825 (ch. 165)	omitted	5815.13	5835.77	20.64

Table 2-8. Occupied bandwidth, 5.8GHz band OFDM mode, TX 54Mbps

Center Frequency (MHz)	Trace number	Lower frequency (MHz)	Upper frequency (MHz)	Bandwidth at 20 dB below (MHz)
5745 (ch. 149)	omitted	5735.55	5754.29	18.74
5785 (ch. 157)	omitted	5775.63	5794.17	18.54
5825 (ch. 165)	omitted	5815.73	5834.27	18.54

2.4 Trace Data of Occupied Bandwidth

The plots are comparatively worse measurement cases of each transmission mode at the bandedge channels (i.e. ch.1 or ch.11) in the previous [Table 2-1](#) through [Table 2-8](#).

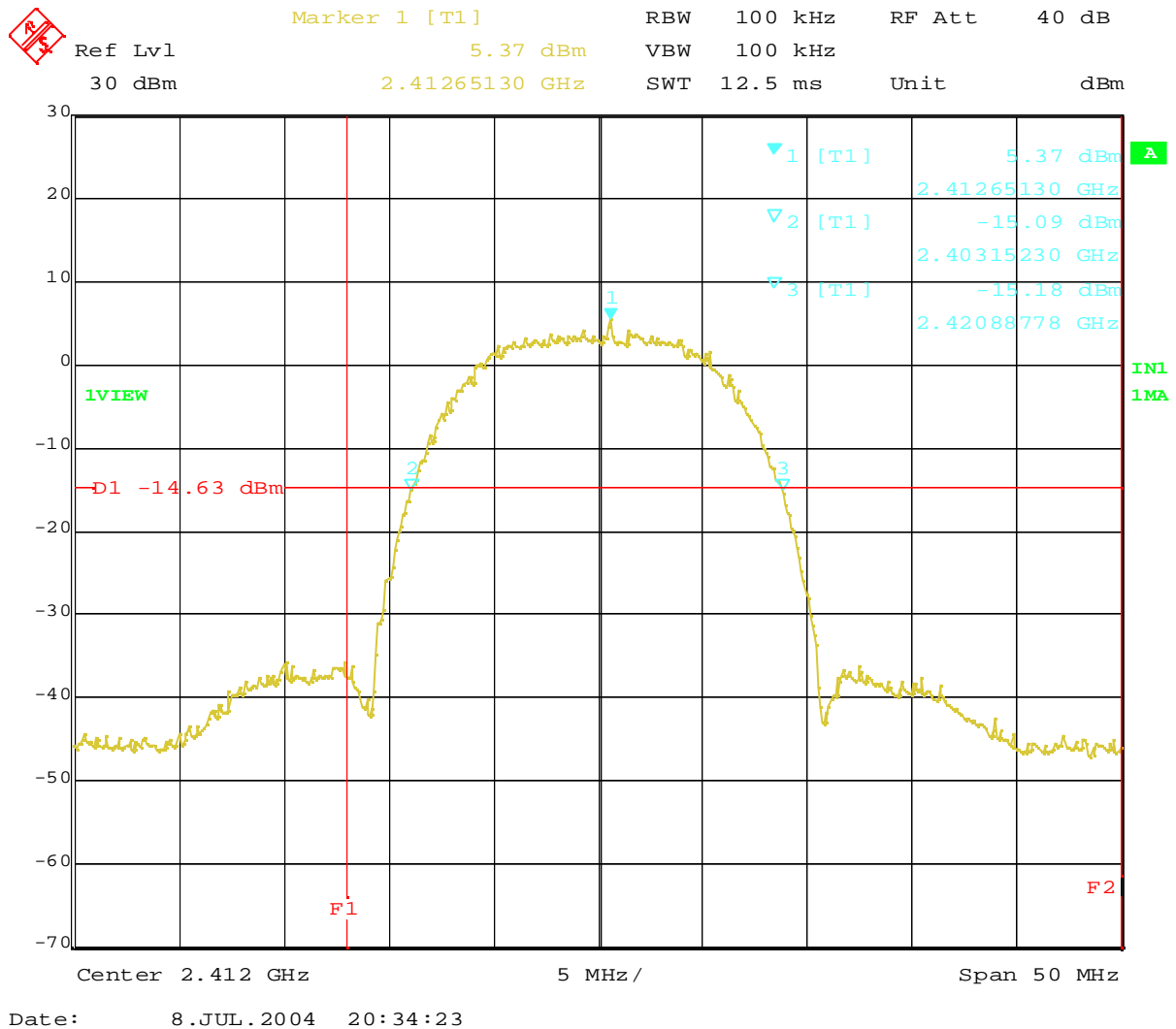

Plot 2-1. 20dB BW at 2412MHz (DSSS, 11Mbps)

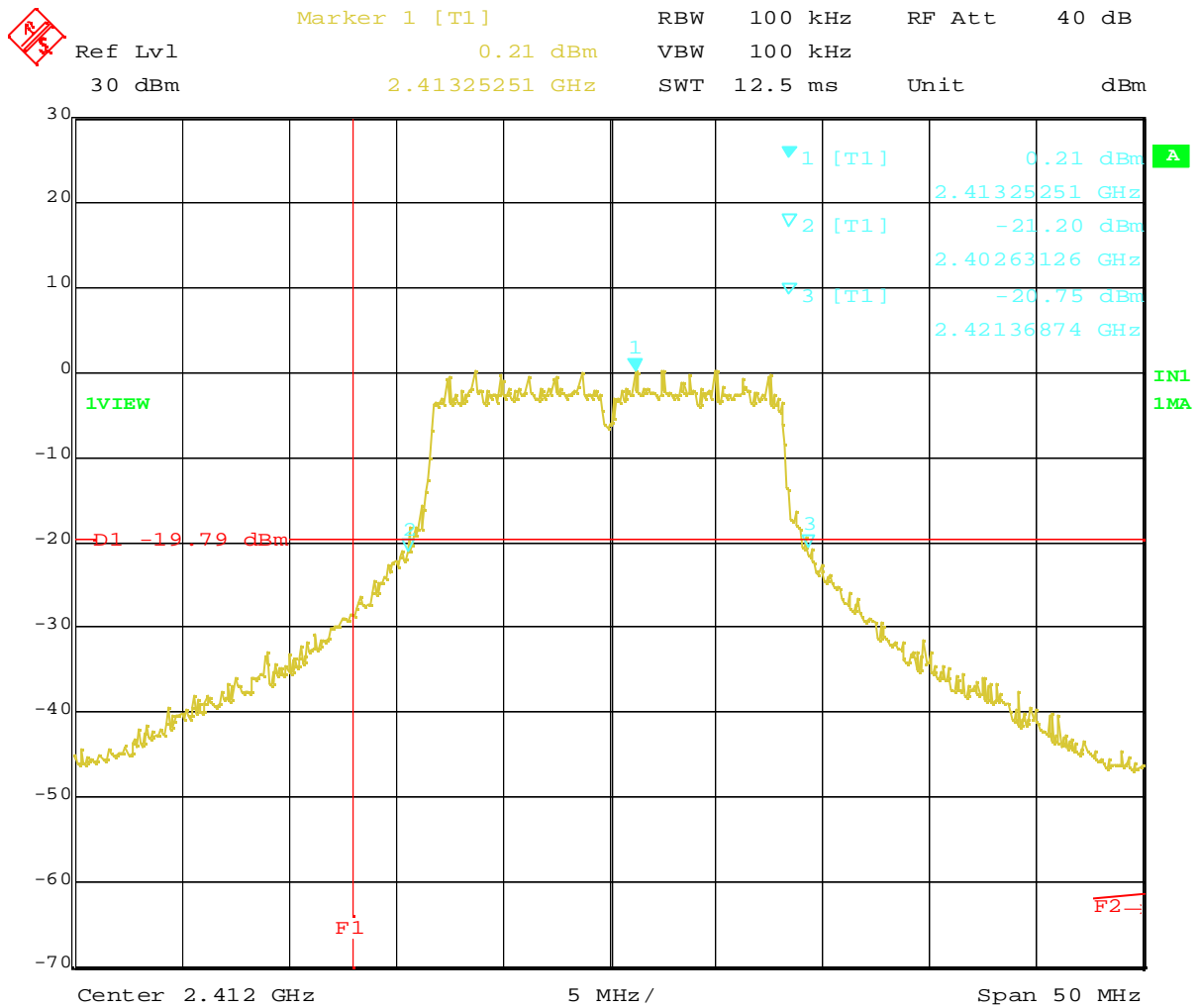

Plot 2-2. 20dB BW at 2412MHz (OFDM, 6Mbps)

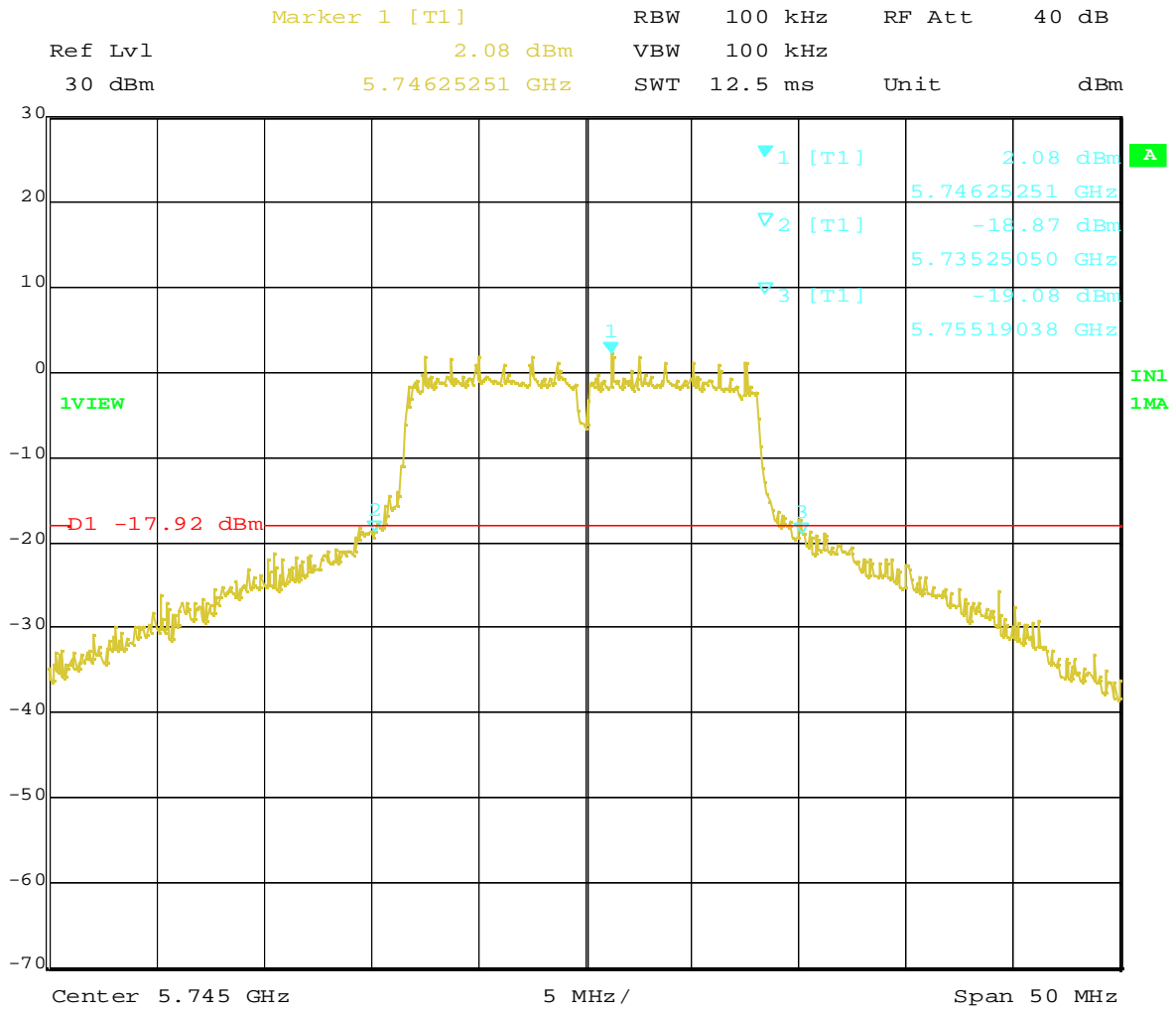

Date: 12.JUL.2004 20:58:12

Plot 2-3. 20dB BW at 5745MHz (OFDM, 6Mbps)

3. Conducted Peak Transmit Output Power [FCC 15.247(b)(3), RSS-210 6.2.2(o)(b)]

3.1 Test Procedure

The spectrum analyzer was connected to the antenna terminal, while EUT was operating in continuous transmission mode at the appropriate center frequencies.

The spectrum analyzer was set to :

RBW=1MHz, VBW=RBW or more, Mode=Peak detection, Trigger=free run,
Span=50MHz encompassing the entire 26 dB emission bandwidth of the transmission signal

The band power measurement function was used to measure the peak power of each transmission mode. The analyzer computed the peak power by integrating the spectrum across the 26 dB emission bandwidth.

3.2 Test Instruments and Measurement Setup

The test instruments and setup configuration are the same as the Table 1-1 and Figure 1.

3.3 Measurement Results

Test Date: July 29, 2004

Table 3-1. Conducted peak output power measurement results

Measured Frequency (MHz)	Tx mode (Mb/s)	Analyzer reading (dBm)	Trace number	Cable Loss (dB)	Results (dBm)	Limit		Margin to limit (dBm)
						FCC (dBm)	IC (dBm)	
2412 (DSSS)	1	17.90	omitted	1.3	19.20 (83.2 mW)	30	30	10.80
	11	21.01	omitted		22.31 (170.2 mW)			7.69
2437 (DSSS)	1	18.60	omitted	1.3	19.90 (97.7 mW)			10.10
	11	21.76	Plot 3-1a		23.06 (202.3 mW)			6.94
2462 (DSSS)	1	17.34	omitted	1.3	18.64 (73.1 mW)			11.36
	11	20.73	omitted		22.03 (159.6 mW)			7.97
2412 (OFDM)	6	20.30	omitted	1.3	21.60 (144.5 mW)			8.40
	18	20.21	omitted		21.51 (141.6 mW)			8.49
	54	20.25	omitted		21.55 (142.9 mW)			8.45
2437 (OFDM)	6	23.38	Plot 3-2a	1.3	24.68 (293.8 mW)			5.32
	18	23.27	omitted		24.57 (286.4 mW)			5.43
	54	20.39	omitted		21.69 (147.6 mW)			8.31
2462 (OFDM)	6	19.91	omitted	1.3	21.21 (132.1 mW)			8.79
	18	19.78	omitted		21.08 (128.2 mW)			8.92
	54	19.89	omitted		21.19 (131.5 mW)	8.81		
5745 (OFDM)	6	21.85	omitted	2.3	24.15 (260.0 mW)	5.85		
	18	21.73	omitted		24.03 (252.9 mW)	5.97		
	54	17.91	omitted		20.21 (105.0 mW)	9.79		
5785 (OFDM)	6	22.49	Plot 3-3a	2.3	24.79 (301.3 mW)	5.21		
	18	22.42	omitted		24.72 (296.5 mW)	5.28		
	54	18.02	omitted		20.32 (107.6 mW)	9.68		
5825 (OFDM)	6	22.21	omitted	2.3	24.51 (282.5 mW)	5.49		
	18	22.15	omitted		24.45 (278.6 mW)	5.55		
	54	17.73	omitted		20.03 (100.7 mW)	9.97		

3.4 Trace Data of Conducted Peak Output Power

The plots are comparatively worse measurement cases of each transmission mode in the previous [Table 3-1](#).

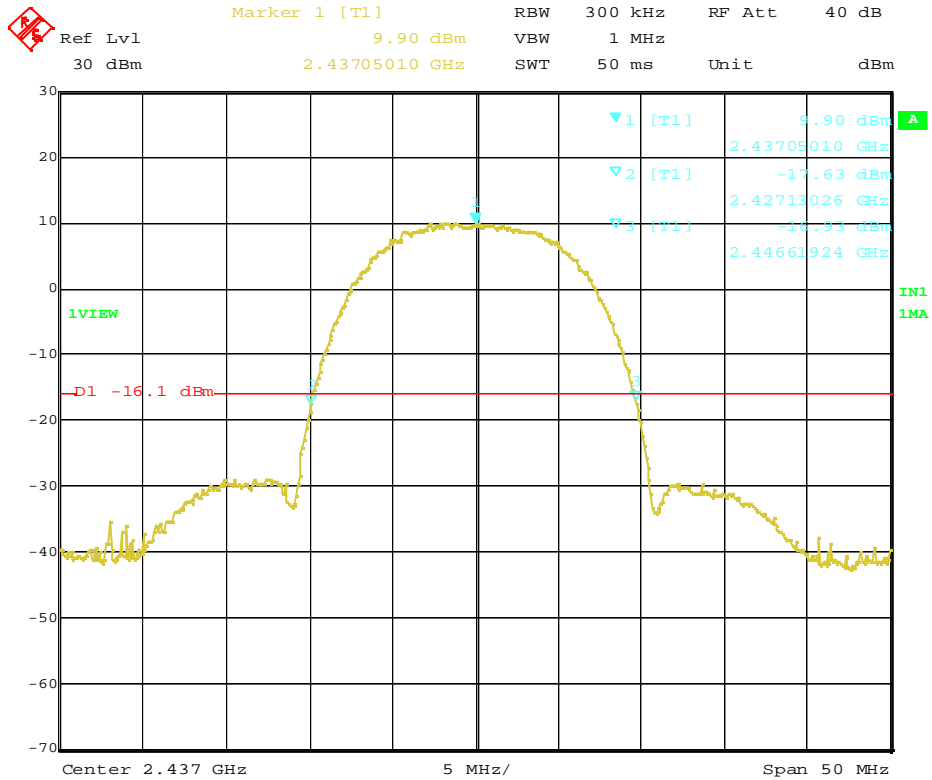

Date: 29.JUL.2004 14:50:46

Plot 3-1a. 26dB Bandwidth of 2437MHz (DSSS, 11Mbps)

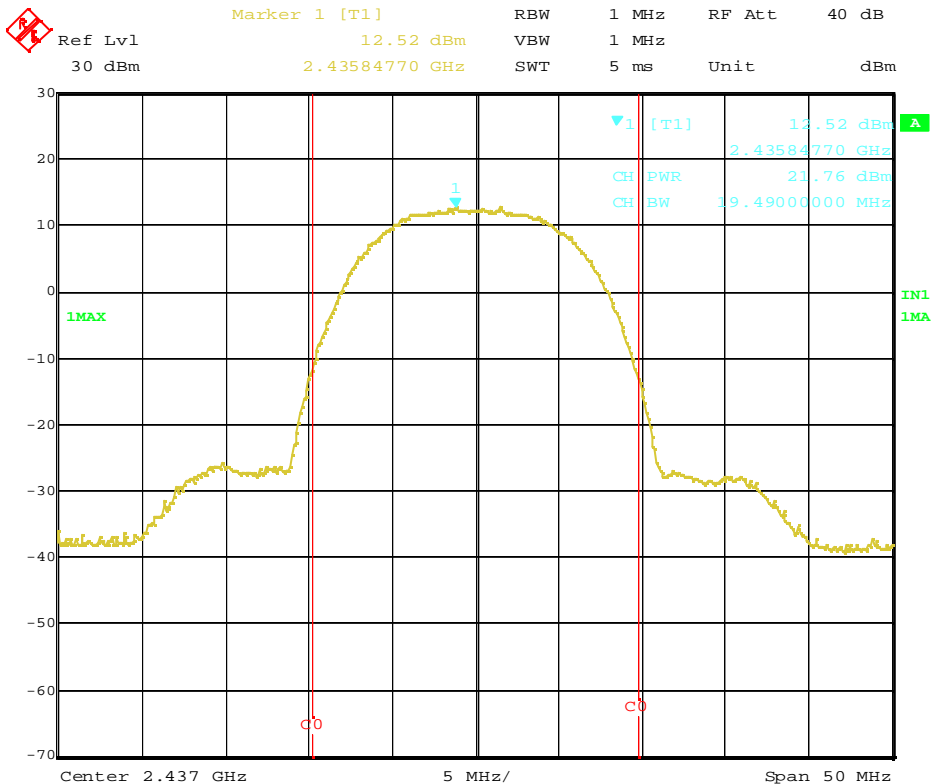

Date: 29.JUL.2004 19:42:10

Plot 3-1b. Conducted Peak Output Power of 2437MHz (DSSS, 11Mbps)

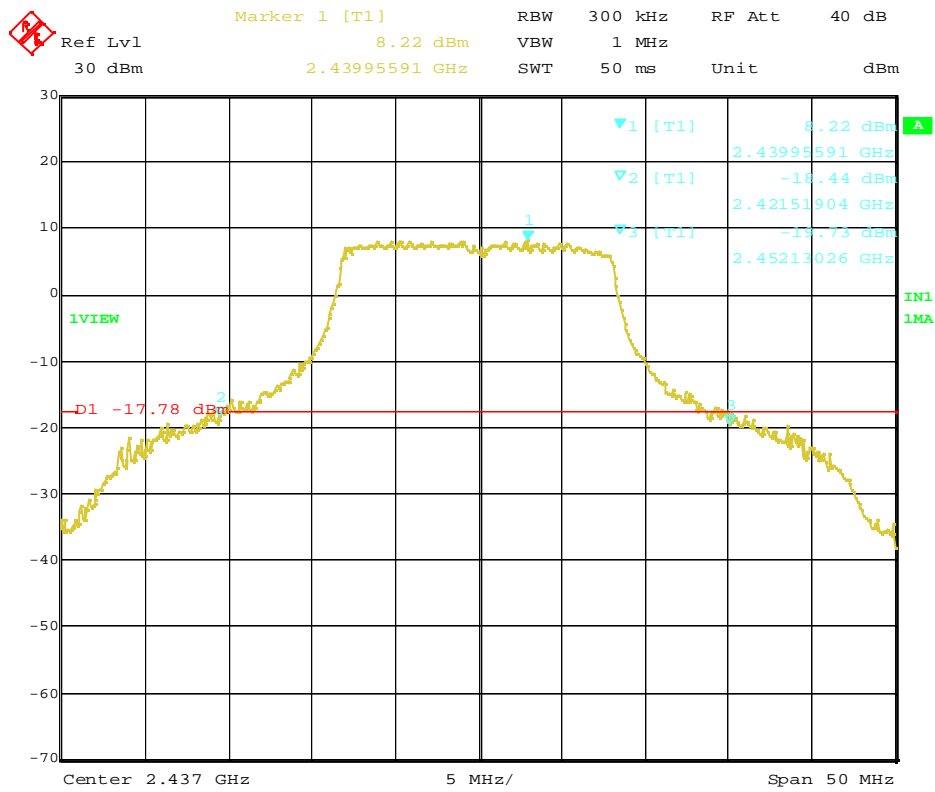

Date: 29.JUL.2004 17:24:20

Plot 3-2a. 26dB Bandwidth of 2437MHz (OFDM, 6Mbps)

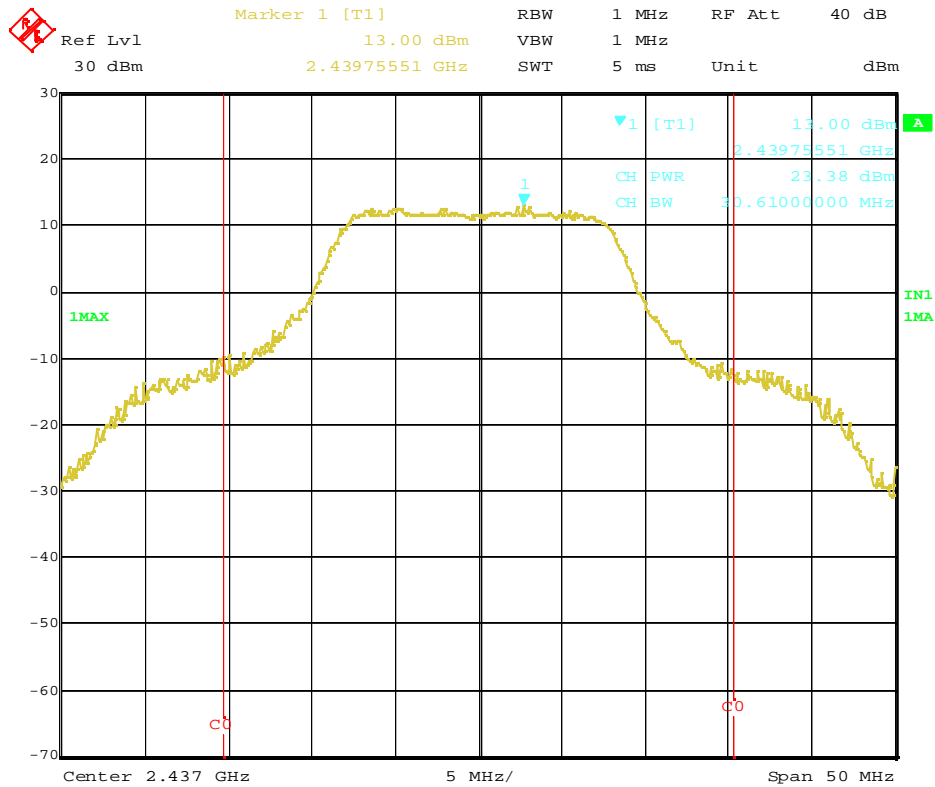

Date: 29.JUL.2004 19:27:00

Plot 3-2b. Conducted Peak Output Power of 2437MHz (OFDM, 6Mbps)

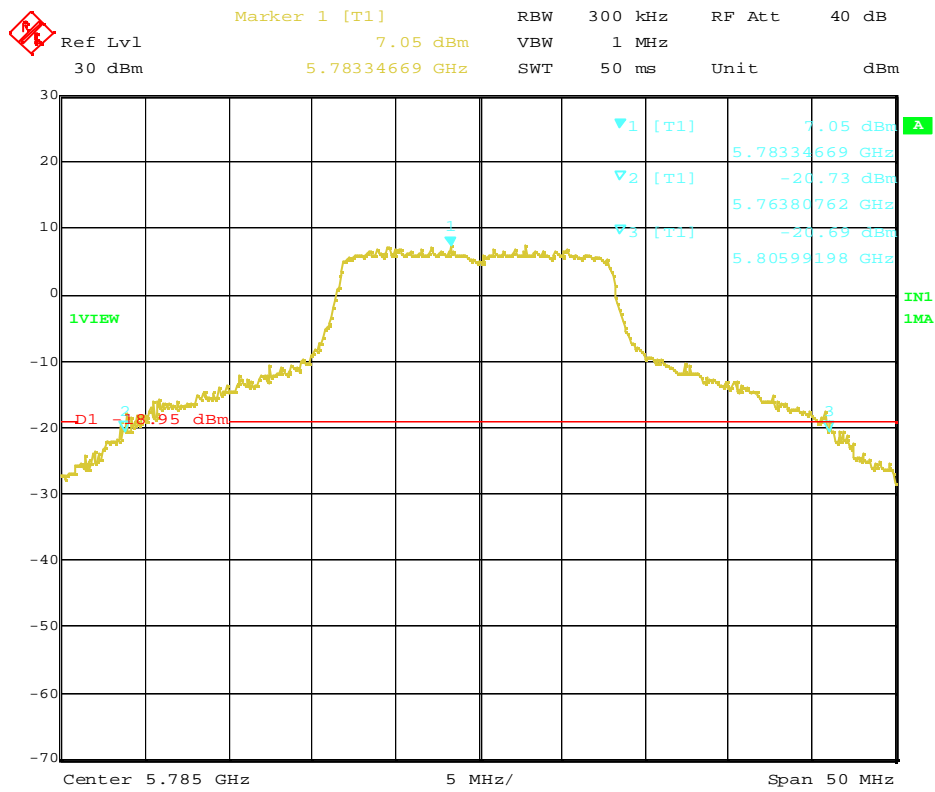

Date: 29.JUL.2004 18:08:15

Plot 3-3a. 26dB Bandwidth of 5785MHz (OFDM, 6Mbps)

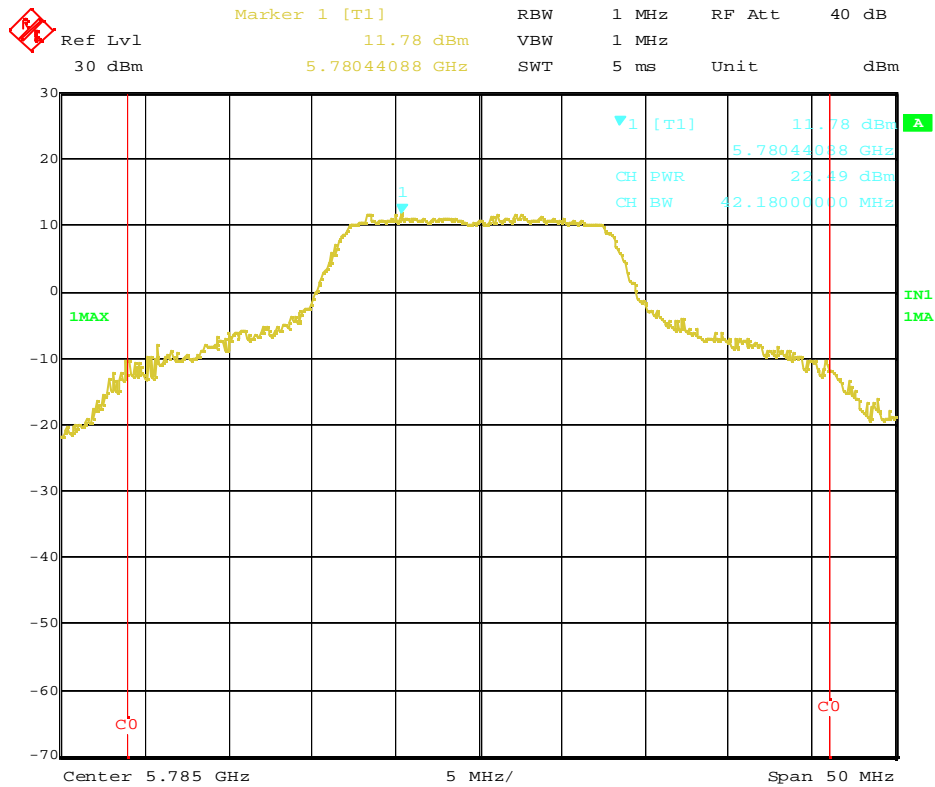

Date: 29.JUL.2004 18:49:18

Plot 3-3b. Conducted Peak Output Power of 5785MHz (OFDM, 6Mbps)

4. Out of Band Emissions (Conducted Spurious) [FCC 15.247(c), RSS-210 6.2.2(o)(e1)]

4.1 Test Procedure

The outband emissions in any 100kHz bandwidth was measured with a spectrum analyzer connected to the antenna terminal, while EUT was operating in transmission mode at the appropriate center frequency. The spectrum analyzer was set to:

2.4GHz: RBW = 100kHz, VBW = 100kHz*1, Scanning frequency range = 30MHz~2GHz, 2GHz~3GHz, and 3GHz~25GHz, Sweep = suitable duration based on the EUT specification, Mode= Peak detector

5.8GHz: RBW = 100kHz, VBW = 100kHz*1, Scanning frequency range = 30MHz~5GHz, 5GHz~6GHz, 6GHz~26.5GHz and 26.5GHz~40GHz, Sweep = suitable duration based on the EUT specification, Mode= Peak detector

*1: To be adjusted accordingly based on the spectrum stability

4.2 Test Instruments and Measurement Setup

4.2.1 Below 26.5GHz

Same as the Chapter 1 (Table 1-1 & Figure 1).

4.2.2 Above 26.5GHz

Table 4-1 Conducted Spurious Test Instrumentation

Description	Model	Serial Number
Spectrum Analyzer	HP 8563E	3416A02248
Harmonic Mixer (26.5 – 40GHz)	Agilent 11970A	011269-001
Coaxialcables: - EUT <=> Mixer (26.5-40GHz) - Mixer <=>Spectrum Analyzer (26.5-40GHz)	Length: Cable loss: 1m 2.9dB (at 40GHz) 1m 2.9dB (at 40GHz)	- SF102-21108 - SF102-21105

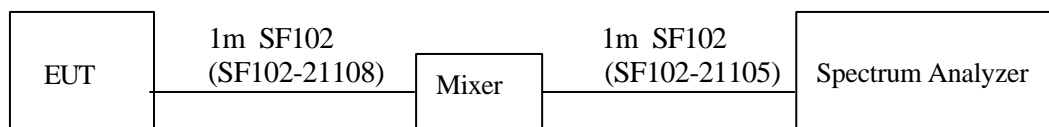

Figure 4: Measurement setup for Conducted Spurious test

4.3 Measurement Results

All conducted emission in any 100kHz bandwidth outside of the spread spectrum band was at least 20dB lower than the highest inband spectral density.

The measurement was performed with the worse cases of each transmission mode, that tend to have higher conducted peak power, based on the results of previous Chapter 3, “Conducted Peak Output Power” measurement.

Test Date: July 12 and 13, 2004 : See the following plots.

Center Frequency (MHz)		Tx Rate (worst case)	Trace number *1
2412 (ch. 1)	DSSS	11Mbps	Plot 4-1
2437 (ch. 6)		11Mbps	Plot 4-2
2462 (ch. 11)		11Mbps	Plot 4-3
2412 (ch. 1)	OFDM	6Mbps	Plot 4-4
2437 (ch. 6)		6Mbps	Plot 4-5
2462 (ch. 11)		6Mbps	Plot 4-6
5745 (ch. 149)	OFDM	6Mbps	Plot 4-7
5785 (ch. 157)		6Mbps	Plot 4-8
5825 (ch. 165)		6Mbps	Plot 4-9

*1 : Each submittal plot includes the highest conducted spurious in the 10th harmonics frequency range of each worst case in measured Tx modes.

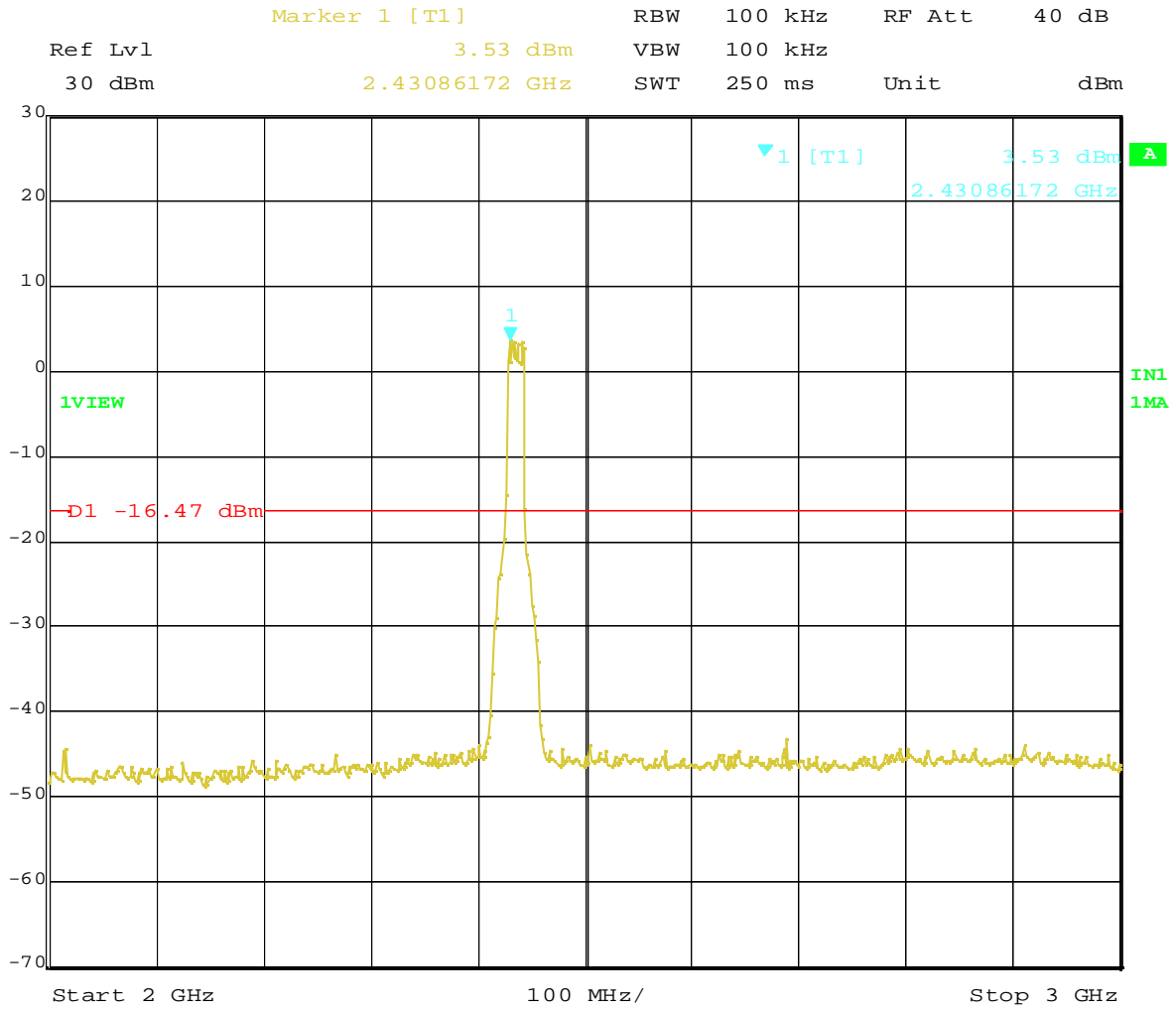

Date: 12.JUL.2004 19:27:59

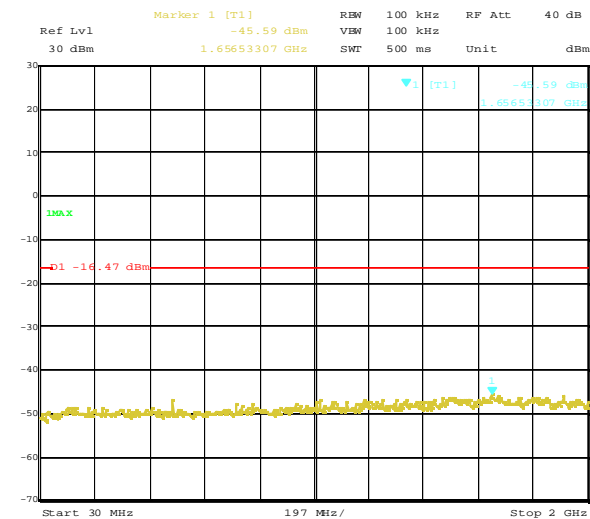

Date: 12.JUL.2004 19:28:43

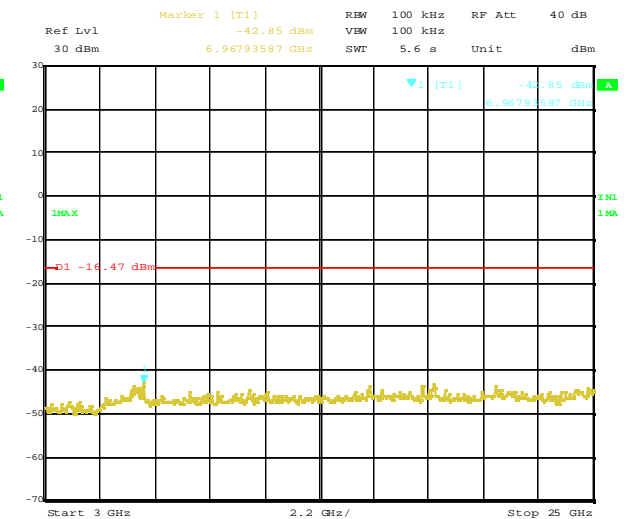

Date: 12.JUL.2004 19:29:20

Plot 4-5. Out of band emissions around 2437MHz (OFDM, 6Mbps)

5. Peak Power Spectral Density

[FCC 15.247(d), RSS-210 6.2.2(o)(b)]

5.1 Test Procedure

The power spectral density was measured with a spectrum analyzer connected to the antenna terminal, while EUT was operating in transmission mode at the appropriate center frequency.

The pre-scanning was performed with the spectrum analyzer to search and locate the center frequency at the peak emission of each transmission mode.

Then, the spectral analyzer was set to the emission peak found in the pre-scan and the peak power spectral density was measured with:

RBW = 3 kHz, VBW = 3 kHz, Span = 300 kHz, Sweep = 100 seconds, Mode= Peak detector

5.2 Test Instruments and Measurement Setup

Same as the Chapter 1 (Table 1-1 & Figure 1).

5.3 Measurement Results

The measurement was performed with the worse cases of each transmission mode, that tend to have higher conducted peak power, based on the results of previous Chapter 3, “Conducted Peak Output Power” measurement.

Test Date: July 12 and 13, 2004

Table 5-1. Peak Power Spectrum Density, TX mode

Ch No.		Frequency (MHz)	Analyzer Reading (dBm)	Trace number	Cable loss (dB)	Result (dBm)	Limit (dBm)	Margin (dB)
DSSS	2.4GHz 11Mbps	1	2411.98	-8.01	omitted	- 6.7	8.0	14.7
		6	2436.98	-6.67	Plot 5-1	- 5.4	8.0	13.4
		11	2461.98	-8.32	omitted	- 7.0	8.0	15.0
OFDM	2.4GHz 6Mbps	1	2411.98	-10.48	omitted	- 9.2	8.0	17.2
		6	2436.98	-9.31	Plot 5-2	- 8.0	8.0	16.0
		11	2461.98	-12.53	omitted	-11.2	8.0	19.2
	5.8GHz 6Mbps	149	5745.58	-11.58	omitted	- 9.3	8.0	17.3
		157	5785.30	-11.46	Plot 5-3	- 9.2	8.0	17.2
		165	5825.58	-11.72	omitted	- 9.4	8.0	17.4

5.4 Trace Data of Peak Power Spectral Density

The plots are comparatively worse measurement cases of each transmission mode in the previous Table 5-1.

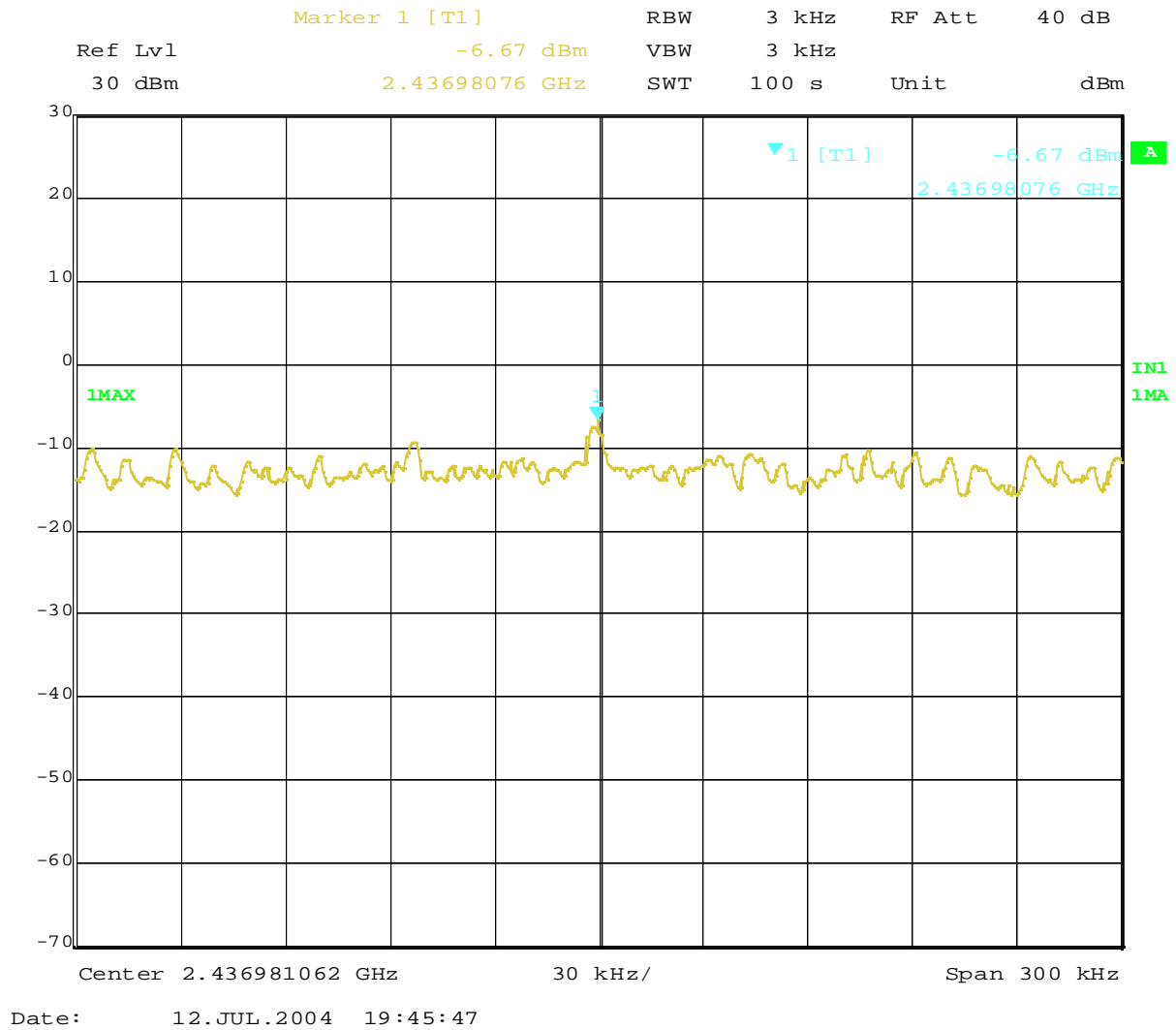

Plot 5-1. Peak Power Spectral Density of 2437MHz (DSSS, 11Mbps)

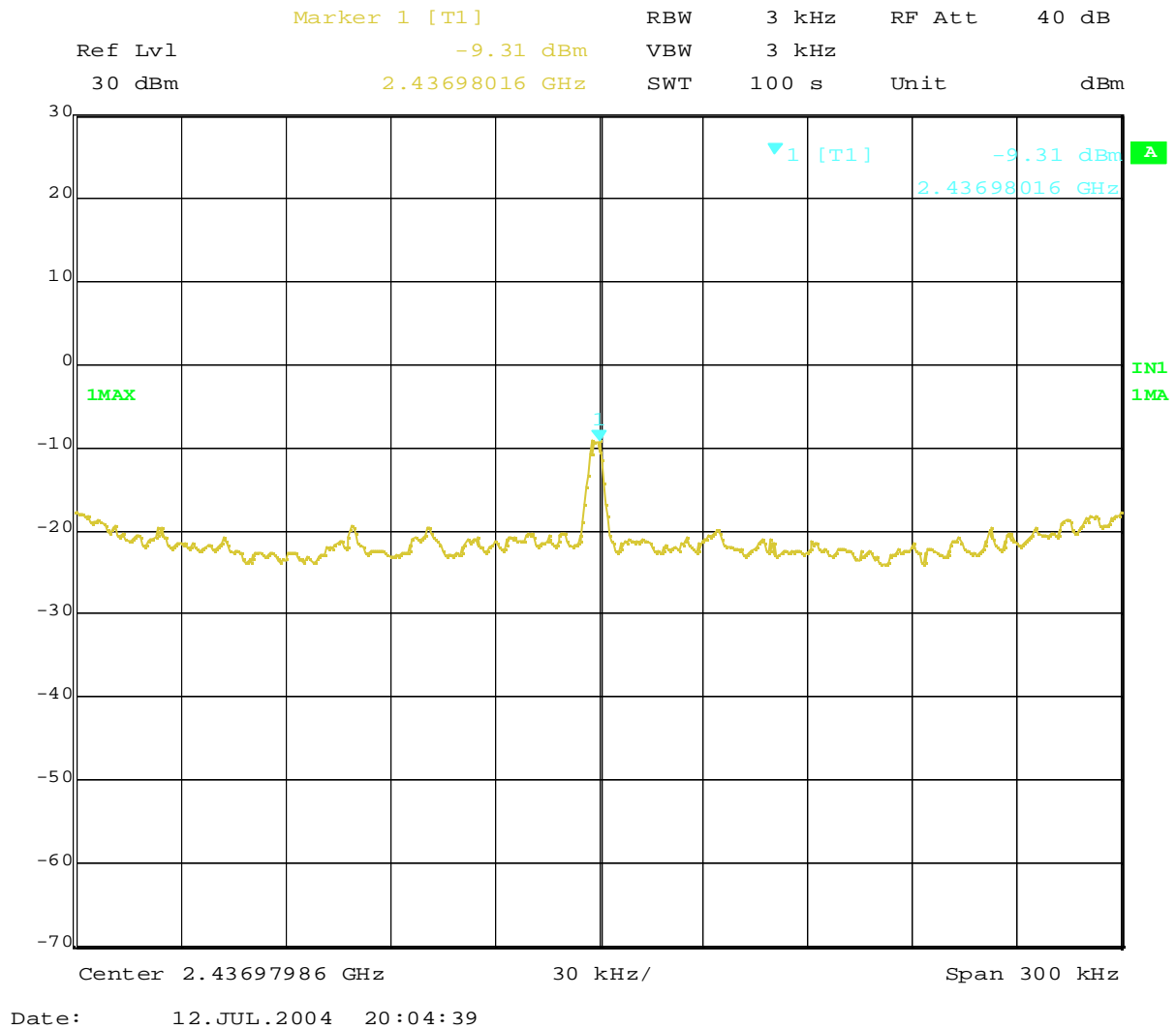

Plot 5-2. Peak Power Spectral Density of 2437MHz (OFDM, 6Mbps)

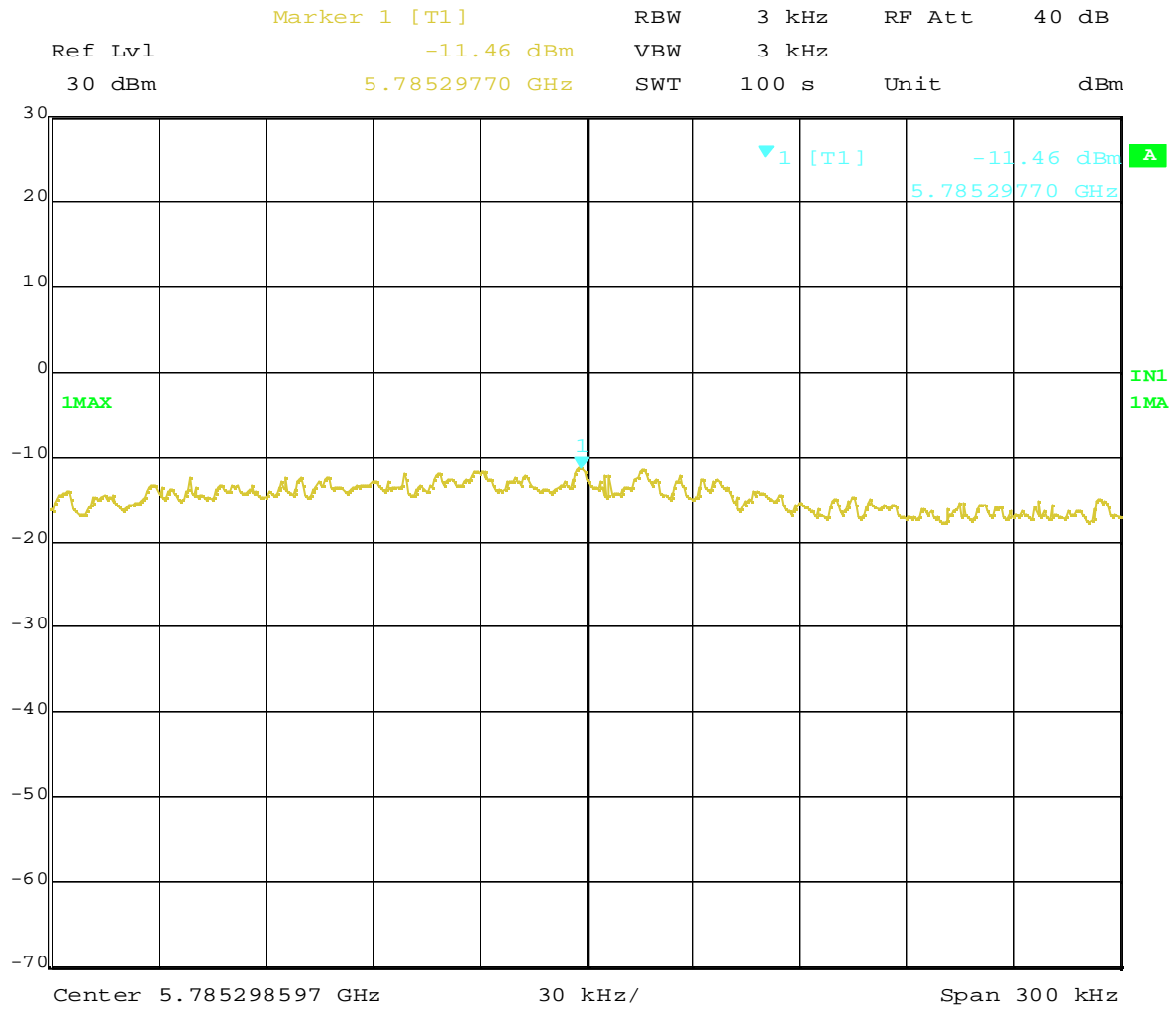

Date: 13.JUL.2004 20:37:34

Plot 5-3. Peak Power Spectral Density of 5785MHz (OFDM, 6Mbps)

6. AC Wireline Conducted Emissions (150KHz – 30MHz) [FCC 15.207, RSS-210 6.6 / 7.4]

6.1 Test Procedure

The conducted emissions are measured in the IBM shielded room with a spectrum analyzer in peak hold. Emissions closest to the limit are measured in the quasi-peak mode (QP) with the tuned receiver using a bandwidth of 9kHz. The emissions are maximized further by cable manipulation. The highest emissions relative to the limit are listed.

6.2 Test Instruments and Measurement Setup

Table 6-1. Conducted Emission Test Instrumentation

Description	Model	Serial Number
Computer	IBM 6589-13J	97-15613
Spectrum Analyzer (100Hz-1.5GHz)	HP 85680B	2841A04254
Spectrum Analyzer Display	HP 85662A	2816A16831
Quasi-Peak Adapter	HP 85650A	2811A01156
Receiver (9kHz-30MHz)	R&S ESH3	891806/012
LISN	EMCO 3810/2NM	00022007
Switch/control unit	HP 3488A	2719A17228
Plotter	HP 7550A	2631A33619
Coax cables: - Lism-L <=> SW/Con.unit (SW100) - Lism-N <=> SW/Con.unit (SW101) - SW/Con.unit <=> RCVR (Input) - SW/Con.unit<=> Spe Ana.(Signal In)	Length: 4 m 4 m 1 m 1 m	- EMIC-L - EMIC-N - EMIC-R - EMIC-S

Notes: - HP: Hewlett Packard, R&S: Rohde & Schwarz

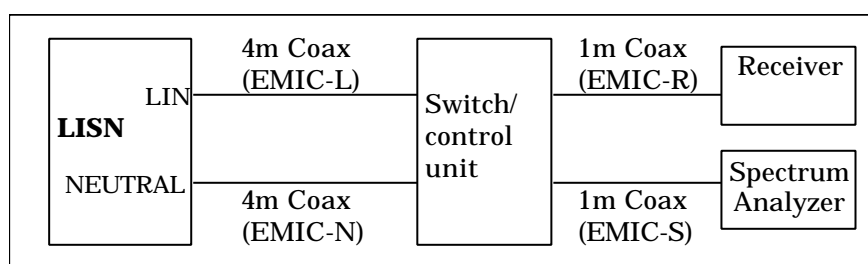

Figure 6. Cables for Conducted Emission Test

6.3 Powerline Voltage Calculation

The powerline voltage is calculated by adding insertion losses of LISN, Cable, Switch control unit and Pulse limiter to the measured reading. All factors are included in the reported data.

$$PV = R + CORR$$

where:

PV = Powerline Voltage (dB μ V)

R = Measured Receiver Input Amplitude (dB μ V)

CORR = Correction Factor (dB) = LL+CL+SWL+PLL

LL = Insertion loss of LISN (dB)

CL = Insertion loss of Cable (dB)

SWL = Insertion loss of Switch control unit (dB)

PLL = Insertion loss of Pulse Limiter (dB)

Given a Receiver input reading of 50.0 dB μ V, LISN loss of 0.6 dB, Cable loss of 0.1dB, Switch control unit loss of 0.1dB and Pulse limiter loss of 0.2dB. The Powerline Voltage of the measured emission is:

$$CORR = 0.6 + 0.1 + 0.1 + 0.2 = 1.0 \text{ (dB)}$$

$$PV = 50.0 + 1.0 = 51.0 \text{ (dB}\mu\text{V)}$$

6.4 Measurement Results

The EUT was found to comply to the limits of FCC Part 15 Subpart C and RSS-210 with a margin of 9.3dB. The 6 highest emissions relative to the limits are reported.

Test Date: July 22, 2004

6.3.1 EUT in 2.4GHz DSSS transmission mode

The actual highest emissions were found on the auxiliary antenna of ThinkPad G40 Series, LCD 14 inch model.

Table 6-2-1. Ch.1 (2412MHz) TX mode 11Mbps

Frequency (MHz)	QP			AV			CISPR22 QP Limit (dBµV)	CISPR22 AV Limit (dBµV)	Phase
	Measured Reading (dBµV)	Corr. Factor (dB)	Powerline Voltage (dBµV)	Measured Reading (dBµV)	Corr. Factor (dB)	Powerline Voltage (dBµV)			
0.3993	37.0	0.6	37.6	35.8	0.6	36.4	57.9	47.9	Line
0.4643	35.6	0.6	36.2	34.8	0.6	35.4	56.6	46.6	Line
0.6033	36.1	0.6	36.7	35.5	0.6	36.1	56.0	46.0	Line
0.8708	33.5	0.6	34.1	32.0	0.6	32.6	56.0	46.0	Line
1.3350	32.4	0.6	33.0	31.2	0.6	31.8	56.0	46.0	Line
10.1683	35.2	1.3	36.5	33.2	1.3	34.5	60.0	50.0	Neutral

Table 6-2-2. Ch.6 (2437MHz) TX mode 11Mbps

Frequency (MHz)	QP			AV			CISPR22 QP Limit (dBµV)	CISPR22 AV Limit (dBµV)	Phase
	Measured Reading (dBµV)	Corr. Factor (dB)	Powerline Voltage (dBµV)	Measured Reading (dBµV)	Corr. Factor (dB)	Powerline Voltage (dBµV)			
0.3988	36.9	0.6	37.5	35.8	0.6	36.4	57.9	47.9	Line
0.4678	36.6	0.6	37.2	35.7	0.6	36.3	56.6	46.6	Line
0.6040	36.3	0.6	36.9	35.5	0.6	36.1	56.0	46.0	Line
0.8740	33.6	0.6	34.2	32.1	0.6	32.7	56.0	46.0	Line
1.8813	32.3	0.7	33.0	30.7	0.7	31.4	56.0	46.0	Line
3.6925	36.6	0.7	37.3	33.2	0.7	33.9	56.0	46.0	Neutral

Table 6-2-3. Ch.11 (2462MHz) TX mode 11Mbps

Frequency (MHz)	QP			AV			CISPR22 QP Limit (dBµV)	CISPR22 AV Limit (dBµV)	Phase
	Measured Reading (dBµV)	Corr. Factor (dB)	Powerline Voltage (dBµV)	Measured Reading (dBµV)	Corr. Factor (dB)	Powerline Voltage (dBµV)			
0.4029	38.7	0.6	39.3	37.9	0.6	38.5	57.8	47.8	Line
0.4699	37.2	0.6	37.8	36.4	0.6	37.0	56.5	46.5	Line
0.6043	36.3	0.6	36.9	35.5	0.6	36.1	56.0	46.0	Line
0.8760	33.8	0.6	34.4	32.4	0.6	33.0	56.0	46.0	Line
1.1454	33.1	0.6	33.7	31.6	0.6	32.2	56.0	46.0	Line
9.9629	35.6	1.1	36.7	33.9	1.1	35.0	60.0	50.0	Neutral

Table 6-2-4. Ch. 6 (2437MHz) **RX** mode

Frequency (MHz)	QP			AV			CISPR22 QP Limit (dBµV)	CISPR22 AV Limit (dBµV)	Phase
	Measured Reading (dBµV)	Corr. Factor (dB)	Powerline Voltage (dBµV)	Measured Reading (dBµV)	Corr. Factor (dB)	Powerline Voltage (dBµV)			
0.2721	37.8	0.6	38.4	36.4	0.6	37.0	61.1	51.1	Line
0.4048	35.4	0.6	36.0	35.0	0.6	35.6	57.8	47.8	Line
0.4698	32.9	0.6	33.5	31.0	0.6	31.6	56.5	46.5	Line
0.6097	35.1	0.6	35.7	33.7	0.6	34.3	56.0	46.0	Line
1.7936	31.3	0.7	32.0	29.2	0.7	29.9	56.0	46.0	Line
3.5831	39.8	0.7	40.5	33.3	0.7	34.0	56.0	46.0	Line

6.3.2 EUT in 2.4GHz OFDM transmission mode

The actual highest emissions were found on the auxiliary antenna of ThinkPad G40 Series, LCD 14 inch model.

Table 6-2-5. Ch.1 (2412MHz) **TX** mode 6Mbps

Frequency (MHz)	QP			AV			CISPR22 QP Limit (dBµV)	CISPR22 AV Limit (dBµV)	Phase
	Measured Reading (dBµV)	Corr. Factor (dB)	Powerline Voltage (dBµV)	Measured Reading (dBµV)	Corr. Factor (dB)	Powerline Voltage (dBµV)			
0.4030	37.9	0.6	38.5	37.0	0.6	37.6	57.8	47.8	Line
0.4748	37.0	0.6	37.6	36.2	0.6	36.8	56.4	46.4	Line
0.6062	36.1	0.6	36.7	35.3	0.6	35.9	56.0	46.0	Line
0.8801	34.2	0.6	34.8	32.8	0.6	33.4	56.0	46.0	Line
1.1473	33.3	0.6	33.9	32.0	0.6	32.6	56.0	46.0	Line
1.6208	32.5	0.6	33.1	31.3	0.6	31.9	56.0	46.0	Line

Table 6-2-6. Ch.6 (2437MHz) **TX** mode 6Mbps

Frequency (MHz)	QP			AV			CISPR22 QP Limit (dBµV)	CISPR22 AV Limit (dBµV)	Phase
	Measured Reading (dBµV)	Corr. Factor (dB)	Powerline Voltage (dBµV)	Measured Reading (dBµV)	Corr. Factor (dB)	Powerline Voltage (dBµV)			
0.4042	38.5	0.6	39.1	37.6	0.6	38.2	57.8	47.8	Line
0.4716	37.3	0.6	37.9	36.4	0.6	37.0	56.5	46.5	Line
0.6067	36.4	0.6	37.0	35.6	0.6	36.2	56.0	46.0	Line
0.8803	33.6	0.6	34.2	32.1	0.6	32.7	56.0	46.0	Line
1.1468	32.7	0.6	33.3	31.3	0.6	31.9	56.0	46.0	Line
1.4204	32.3	0.6	32.9	30.5	0.6	31.1	56.0	46.0	Line

Table 6-2-7. Ch.11 (2462MHz) **TX** mode 6Mbps

Frequency (MHz)	QP			AV			CISPR22 QP Limit (dBµV)	CISPR22 AV Limit (dBµV)	Phase
	Measured Reading (dBµV)	Corr. Factor (dB)	Powerline Voltage (dBµV)	Measured Reading (dBµV)	Corr. Factor (dB)	Powerline Voltage (dBµV)			
0.4044	38.5	0.6	39.1	37.7	0.6	38.3	57.8	47.8	Line
0.4738	37.0	0.6	37.6	36.2	0.6	36.8	56.4	46.4	Line
0.6089	36.1	0.6	36.7	35.4	0.6	36.0	56.0	46.0	Line
0.8793	34.0	0.6	34.6	32.7	0.6	33.3	56.0	46.0	Line
1.1483	33.6	0.6	34.2	32.2	0.6	32.8	56.0	46.0	Line
1.8924	32.9	0.7	33.6	31.4	0.7	32.1	56.0	46.0	Line

Table 6-2-8. Ch.6 (2437MHz) **RX** mode

Frequency (MHz)	QP			AV			CISPR22 QP Limit (dBµV)	CISPR22 AV Limit (dBµV)	Phase
	Measured Reading (dBµV)	Corr. Factor (dB)	Powerline Voltage (dBµV)	Measured Reading (dBµV)	Corr. Factor (dB)	Powerline Voltage (dBµV)			
0.2684	37.8	0.6	38.4	36.4	0.6	37.0	61.2	51.2	Line
0.4050	35.2	0.6	35.8	34.8	0.6	35.4	57.7	47.7	Line
0.4712	32.4	0.6	33.0	30.5	0.6	31.1	56.5	46.5	Line
0.6125	34.7	0.6	35.3	33.4	0.6	34.0	56.0	46.0	Line
0.9513	32.5	0.6	33.1	29.6	0.6	30.2	56.0	46.0	Line
1.5278	32.4	0.6	33.0	30.4	0.6	31.0	56.0	46.0	Line

6.3.3 EUT in 5.8GHz OFDM transmission mode

The actual highest emissions were found on the main antenna of ThinkPad G40 Series, LCD 14 inch model.

Table 6-2-9. Ch.1 (5745MHz) **TX** mode 6Mbps

Frequency (MHz)	QP			AV			CISPR22 QP Limit (dBµV)	CISPR22 AV Limit (dBµV)	Phase
	Measured Reading (dBµV)	Corr. Factor (dB)	Powerline Voltage (dBµV)	Measured Reading (dBµV)	Corr. Factor (dB)	Powerline Voltage (dBµV)			
0.4050	38.2	0.6	38.8	37.4	0.6	38.0	57.8	47.8	Line
0.4756	37.3	0.6	37.9	36.5	0.6	37.1	56.4	46.4	Line
0.6116	35.9	0.6	36.5	35.1	0.6	35.7	56.0	46.0	Line
0.8830	33.8	0.6	34.4	32.4	0.6	33.0	56.0	46.0	Line
1.6279	32.6	0.6	33.2	31.2	0.6	31.8	56.0	46.0	Line
3.5909	34.7	0.7	35.4	30.5	0.7	31.2	56.0	46.0	Line

Table 6-2-10. Ch.6 (5785MHz) **TX** mode 6Mbps

Frequency (MHz)	QP			AV			CISPR22 QP Limit (dBµV)	CISPR22 AV Limit (dBµV)	Phase
	Measured Reading (dBµV)	Corr. Factor (dB)	Powerline Voltage (dBµV)	Measured Reading (dBµV)	Corr. Factor (dB)	Powerline Voltage (dBµV)			
0.4040	37.8	0.6	38.4	36.9	0.6	37.5	57.8	47.8	Line
0.4751	37.1	0.6	37.7	36.3	0.6	36.9	56.4	46.4	Line
0.5410	35.7	0.6	36.3	34.6	0.6	35.2	56.0	46.0	Neutral
0.6099	36.1	0.6	36.7	35.4	0.6	36.0	56.0	46.0	Line
0.8809	34.2	0.6	34.8	32.8	0.6	33.4	56.0	46.0	Line
1.1516	33.5	0.6	34.1	32.0	0.6	32.6	56.0	46.0	Line

Table 6-2-11. Ch.11 (5825MHz) **TX** mode 6Mbps

Frequency (MHz)	QP			AV			CISPR22 QP Limit (dBµV)	CISPR22 AV Limit (dBµV)	Phase
	Measured Reading (dBµV)	Corr. Factor (dB)	Powerline Voltage (dBµV)	Measured Reading (dBµV)	Corr. Factor (dB)	Powerline Voltage (dBµV)			
0.4049	38.3	0.6	38.9	37.4	0.6	38.0	57.8	47.8	Line
0.4740	37.3	0.6	37.9	36.5	0.6	37.1	56.4	46.4	Line
0.6095	35.9	0.6	36.5	35.2	0.6	35.8	56.0	46.0	Line
0.8816	33.4	0.6	34.0	32.1	0.6	32.7	56.0	46.0	Line
1.1522	32.9	0.6	33.5	31.4	0.6	32.0	56.0	46.0	Line
1.6257	32.5	0.6	33.1	31.2	0.6	31.8	56.0	46.0	Line

Table 6-2-12. Ch.6 (5875MHz) RX mode

Frequency (MHz)	QP			AV			CISPR22 QP Limit (dBµV)	CISPR22 AV Limit (dBµV)	Phase
	Measured Reading (dBµV)	Corr. Factor (dB)	Powerline Voltage (dBµV)	Measured Reading (dBµV)	Corr. Factor (dB)	Powerline Voltage (dBµV)			
0.2723	38.5	0.6	39.1	37.1	0.6	37.7	61.0	51.0	Line
0.4048	34.9	0.6	35.5	34.5	0.6	35.1	57.8	47.8	Line
0.4731	33.8	0.6	34.4	32.0	0.6	32.6	56.5	46.5	Line
0.6126	34.4	0.6	35.0	33.2	0.6	33.8	56.0	46.0	Line
1.8694	31.3	0.7	32.0	28.2	0.7	28.9	56.0	46.0	Line
3.5303	38.3	0.7	39.0	33.1	0.7	33.8	56.0	46.0	Neutral

7. Restricted Bands Radiation (30MHz – 1GHz) [FCC 15.205 / 209, RSS-210 6.3 / 7.3]

7.1 Test Procedure

Preliminary radiated emissions are measured in the semi-anechoic chamber at a 3 meter distance on every azimuth in both horizontal and vertical polarity. The antennas are also scanned in height. The emissions are recorded with a spectrum analyzer in peak hold mode. The identified emissions are further maximized by a cable manipulation. Emissions closest to the limits are measured in the quasi-peak mode with the tuned receiver using a bandwidth of 120kHz. The highest emissions relative to the limit are listed.

7.2 Test Instruments and Measurement Setup

Table 7-1 Radiated Emission Test Instrumentation

Description	Model	Serial Number
Computer	IBM 6868-30J	97-901X3
Spectrum Analyzer (100Hz-1.5GHz) for 30-200MHz	HP 85680B	2601A02634
Spectrum Analyzer Display for 30-200MHz	HP 85662A	2542A12308
Quasi-Peak Adapter for 30-200MHz	HP 85650A	2043A00062
Spectrum Analyzer (100Hz-1.5GHz) for 200-1000MHz	HP 85680B	3019A05156
Spectrum Analyzer Display for 200-1000MHz	HP 85662A	3026A19366
Quasi-Peak Adapter for 200-1000MHz	HP 85650A	2811A01433
Amplifier (100KHz-1.3GHz) - for 30-200MHz - for 200-1000MHz	MITEQ AM-3A MITEQ AM-3A	898433 898432
Biconical Antenna (30-200MHz)	EMCO 3108	2536
Log-Periodic Antenna (200-1000MHz)	EMCO 3146	2849
Receiver (20MHz-1.3GHz)	R&S ESVP	892111/030
Switch/control unit	HP 3488A	2719A17226
N-Coax cables: - Bi-coni Ant <=> 10m Cable - 10m Cable <=> Shield Panel - Shield Panel <=> RF Amp - RF Amp <=> Power Splitter - Log-peri Ant <=> 10m Cable - 10m Cable <=> Shield Panel - Shield Panel <=> RF Amp - RF Amp <=> Power Splitter	Length: 9 m 10 m 7 m 0.5m 9 m 10 m 7 m 0.5m	- EM103L01 - EM103L02 - EM103L03 - EM103L04 - EM103H01 - EM103H02 - EM103H03 - EM103H04
Coax cables: - Power Splitter <=> SW/Con.unit (SW110) - Power Splitter <=> SW/Con.unit (SW300) - Power Splitter <=> SW/Con.unit (SW100) - Power Splitter <=> SW/Con.unit (SW301) - SW/Con.unit <=> Receiver (Input) - SW/Con.unit <=> Spe Ana.(Signal In) for 30- 200MHz - SW/Con.unit <=> Spe Ana.(Signal In) for 200-1000MHz	1 m 1 m 1 m 1 m 2 m 2 m 2 m	- EM103L05 - EM103L06 - EM103H05 - EM103H06 - EM1RCV - EM1SPL - EM1SPH

Notes:
 - HP: Hewlett Packard, R&S: Rohde & Schwarz

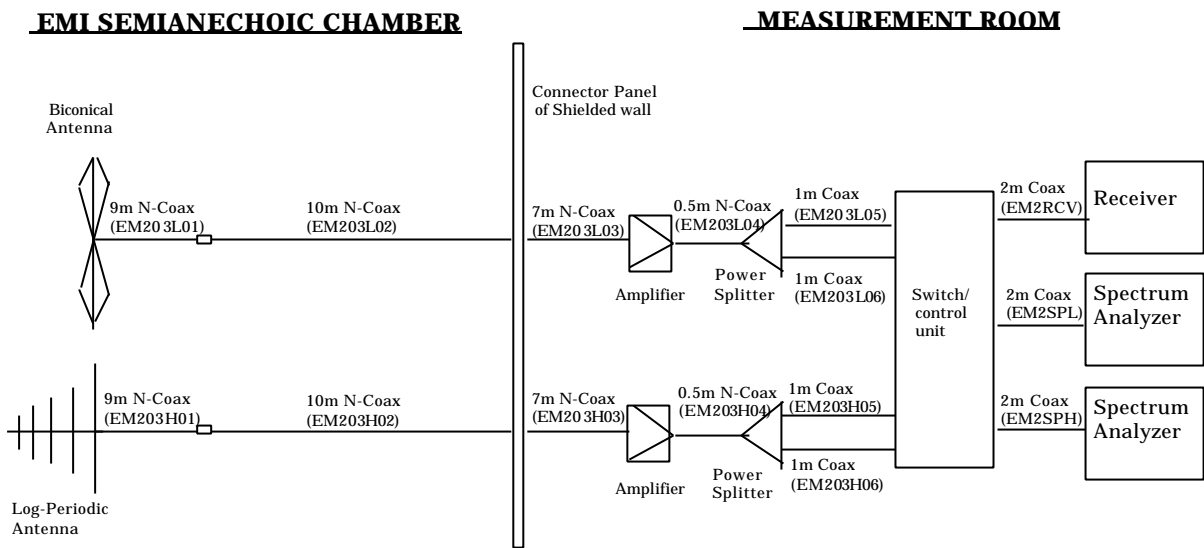

Figure 7 Cables for Radiated Emission Test

7.3 Field Strength Calculation

The field strength is calculated by adding the Antenna Factor and Cable Loss, and subtracting Amplifier Gain from the measured reading. In this test facility, the Antenna Factor, Cable Loss, and Amplifier Gains are loaded into the Rohde & Schwarz Receiver and the corrected field strength can be read directly on the receiver. All factors are included in the reported data.

$$FS = R + AF + CORR$$

where:

FS	=	Field Strength
R	=	Measured Receiver Input Amplitude
AF	=	Antenna Factor
CORR	=	Correction Factor = CL - AG
CL	=	Cable Loss
AG	=	Amplifier Gain

For example :

Given a Receiver input reading of 51.5dB μ V; Antenna Factor of 8.5dB/m; Cable Loss of 1.3dB; and an Amplifier Gain of 26dB. The Field Strength of the measured emission is:

$$FS = 51.5 + 8.5 + 1.3 - 26.0 = 35.3\text{dB}\mu\text{V/m}$$

Conversion between dB μ V/m (or dB μ V) and μ V/m (or μ V) are done as:

$$\text{Level}(\text{dB}\mu\text{V/m}) = 20 \times \text{Log}(\text{Level}(\mu\text{V/m}))$$

$$40\text{dB}\mu\text{V/m} = 100\mu\text{V/m}$$

$$48\text{dB}\mu\text{V/m} = 250\mu\text{V/m}$$

7.4 Measurement Results

The EUT was found to comply to the limits of FCC Part 15 Subpart C and RSS-210 with a margin of 4.1 dB at 30MHz - 1000MHz band.

The 6 highest emissions relative to the limits are reported.

Test Date: July 23 and 26, 2004

7.4.1 EUT in 2.4GHz DSSS transmission mode

The actual highest emissions were found on the auxiliary antenna of ThinkPad G40 Series, LCD 14 inch model.

Table 7-2-1. Ch.1 (2412MHz) TX mode 11Mbps

Frequency (MHz)	Polarity (H/V)	Measured (dBμV)	Antenna Factor (dB/m)	Corr. Factor (dB)	Field Strength (dBμV/m)	Limit (dBμV/m)	Field Strength (μV/m)	Limit (μV/m)
63.994	V	54.7	8.8	-28.6	34.9	40.0	55.6	100
331.991	V	41.9	14.2	-23.5	32.6	46.0	42.7	200
386.576	V	46.3	14.9	-23.1	38.1	46.0	80.4	200
464.632	V	41.4	16.8	-21.9	36.3	46.0	65.3	200
664.096	V	39.2	20.4	-19.9	39.7	46.0	96.6	200
864.626	H	33.5	22.3	-18.9	36.9	46.0	70.0	200

Table 7-2-2. Ch.6 (2437MHz) TX mode 11Mbps

Frequency (MHz)	Polarity (H/V)	Measured (dBμV)	Antenna Factor (dB/m)	Corr. Factor (dB)	Field Strength (dBμV/m)	Limit (dBμV/m)	Field Strength (μV/m)	Limit (μV/m)
62.322	V	53.9	9.0	-28.7	34.2	40.0	51.3	100
331.344	H	43.3	14.2	-23.5	34.0	46.0	50.1	200
386.575	V	45.9	14.9	-23.1	37.7	46.0	76.7	200
464.161	V	40.6	16.8	-21.9	35.5	46.0	59.6	200
664.734	V	39.7	20.4	-19.9	40.2	46.0	102.3	200
863.497	H	31.8	22.3	-18.7	35.4	46.0	58.9	200

Table 7-2-3. Ch.11 (2462MHz) TX mode 11Mbps

Frequency (MHz)	Polarity (H/V)	Measured (dBμV)	Antenna Factor (dB/m)	Corr. Factor (dB)	Field Strength (dBμV/m)	Limit (dBμV/m)	Field Strength (μV/m)	Limit (μV/m)
62.239	V	54.0	9.0	-28.7	34.3	40.0	51.9	100
331.577	H	43.0	14.2	-23.5	33.7	46.0	48.4	200
386.575	V	45.6	14.9	-23.1	37.4	46.0	74.1	200
464.097	V	40.6	16.8	-21.9	35.5	46.0	59.6	200
664.065	V	39.7	20.4	-19.9	40.2	46.0	102.3	200
864.108	H	33.8	22.3	-18.9	37.2	46.0	72.4	200

Table 7-2-4. Ch.6 (2437MHz) RX mode

Frequency (MHz)	Polarity (H/V)	Measured (dBμV)	Antenna Factor (dB/m)	Corr. Factor (dB)	Field Strength (dBμV/m)	Limit (dBμV/m)	Field Strength (μV/m)	Limit (μV/m)
35.509	V	48.3	12.5	-29.2	31.6	40.0	38.0	100
62.180	V	55.5	9.0	-28.7	35.8	40.0	61.7	100
386.574	V	46.4	14.9	-23.1	38.2	46.0	81.3	200
451.277	V	39.6	16.4	-21.8	34.2	46.0	51.3	200
463.825	V	40.8	16.8	-21.9	35.7	46.0	61.0	200
664.860	V	38.0	20.5	-20.2	38.3	46.0	82.2	200

7.4.2 EUT in 2.4GHz OFDM transmission mode

The actual highest emissions were found on the auxiliary antenna of ThinkPad G40 Series, LCD 14 inch model.

Table 7-2-5. Ch.1 (2412MHz) **TX** mode 6Mbps

Frequency (MHz)	Polarity (H/V)	Measured (dBμV)	Antenna Factor (dB/m)	Corr. Factor (dB)	Field Strength (dBμV/m)	Limit (dBμV/m)	Field Strength (μV/m)	Limit (μV/m)
62.317	V	54.3	9.0	-28.7	34.6	40.0	53.7	100
386.575	V	46.1	14.9	-23.1	37.9	46.0	78.5	200
451.322	V	39.1	16.4	-21.8	33.7	46.0	48.4	200
464.078	V	39.6	16.8	-21.9	34.5	46.0	53.1	200
664.136	V	40.2	20.4	-19.9	40.7	46.0	108.4	200
863.297	H	31.1	22.3	-18.7	34.7	46.0	54.3	200

Table 7-2-6. Ch.6 (2437MHz) **TX** mode 6Mbps

Frequency (MHz)	Polarity (H/V)	Measured (dBμV)	Antenna Factor (dB/m)	Corr. Factor (dB)	Field Strength (dBμV/m)	Limit (dBμV/m)	Field Strength (μV/m)	Limit (μV/m)
62.009	V	54.1	9.1	-28.6	34.6	40.0	53.7	100
386.575	V	46.4	14.9	-23.1	38.2	46.0	81.3	200
451.656	V	41.7	16.4	-21.8	36.3	46.0	65.3	200
463.909	V	40.3	16.8	-21.9	35.2	46.0	57.5	200
664.661	V	38.6	20.4	-19.9	39.1	46.0	90.2	200
863.296	H	31.4	22.3	-18.7	35.0	46.0	56.2	200

Table 7-2-7. Ch.11 (2462MHz) **TX** mode 6Mbps

Frequency (MHz)	Polarity (H/V)	Measured (dBμV)	Antenna Factor (dB/m)	Corr. Factor (dB)	Field Strength (dBμV/m)	Limit (dBμV/m)	Field Strength (μV/m)	Limit (μV/m)
61.965	V	53.8	9.1	-28.6	34.3	40.0	51.9	100
386.575	V	46.9	14.9	-23.1	38.7	46.0	86.1	200
451.237	V	41.4	16.4	-21.8	36.0	46.0	63.1	200
464.091	V	40.6	16.8	-21.9	35.5	46.0	59.6	200
664.967	V	36.6	20.5	-20.2	36.9	46.0	70.0	200
864.108	H	33.0	22.3	-18.9	36.4	46.0	66.1	200

Table 7-2-8. Ch.6 (2437MHz) **RX** mode

Frequency (MHz)	Polarity (H/V)	Measured (dBμV)	Antenna Factor (dB/m)	Corr. Factor (dB)	Field Strength (dBμV/m)	Limit (dBμV/m)	Field Strength (μV/m)	Limit (μV/m)
62.863	V	55.6	8.8	-28.5	35.9	40.0	62.4	100
331.370	H	42.5	14.2	-23.5	33.2	46.0	45.7	200
386.573	V	45.9	14.9	-23.1	37.7	46.0	76.7	200
464.310	V	40.2	16.8	-21.9	35.1	46.0	56.9	200
664.837	V	37.5	20.5	-20.2	37.8	46.0	77.6	200
862.658	H	32.2	22.3	-18.7	35.8	46.0	61.7	200

7.4.3 EUT in 5.8GHz OFDM transmission mode

The actual highest emissions were found on the main antenna of ThinkPad G40 Series, LCD 14 inch model.

Table 7-2-9. Ch.1 (5745MHz) **TX** mode 6Mbps

Frequency (MHz)	Polarity (H/V)	Measured (dBμV)	Antenna Factor (dB/m)	Corr. Factor (dB)	Field Strength (dBμV/m)	Limit (dBμV/m)	Field Strength (μV/m)	Limit (μV/m)
61.755	V	50.5	9.1	-28.6	31.0	40.0	35.5	100
386.574	V	45.2	14.9	-23.1	37.0	46.0	70.8	200
451.392	V	41.0	16.4	-21.8	35.6	46.0	60.3	200
464.420	V	41.0	16.8	-21.9	35.9	46.0	62.4	200
663.253	V	36.6	20.4	-20.3	36.7	46.0	68.4	200
875.014	V	30.3	22.6	-18.6	34.3	46.0	51.9	200

Table 7-2-10. Ch.6 (5785MHz) **TX** mode 6Mbps

Frequency (MHz)	Polarity (H/V)	Measured (dBμV)	Antenna Factor (dB/m)	Corr. Factor (dB)	Field Strength (dBμV/m)	Limit (dBμV/m)	Field Strength (μV/m)	Limit (μV/m)
61.813	V	50.7	9.1	-28.5	31.3	40.0	36.7	100
386.574	V	45.4	14.9	-23.1	37.2	46.0	72.4	200
451.527	V	40.7	16.4	-21.8	35.3	46.0	58.2	200
465.300	V	40.5	16.8	-21.8	35.5	46.0	59.6	200
663.386	V	35.7	20.4	-20.3	35.8	46.0	61.7	200
864.289	H	32.2	22.3	-18.9	35.6	46.0	60.3	200

Table 7-2-11. Ch.11 (5825MHz) **TX** mode 6Mbps

Frequency (MHz)	Polarity (H/V)	Measured (dBμV)	Antenna Factor (dB/m)	Corr. Factor (dB)	Field Strength (dBμV/m)	Limit (dBμV/m)	Field Strength (μV/m)	Limit (μV/m)
61.993	V	51.2	9.1	-28.6	31.7	40.0	38.5	100
386.575	V	46.6	14.9	-23.1	38.4	46.0	83.2	200
450.796	V	39.1	16.4	-21.8	33.7	46.0	48.4	200
464.201	V	40.6	16.8	-21.9	35.5	46.0	59.6	200
661.976	V	34.1	20.3	-20.4	34.0	46.0	50.1	200
861.910	H	31.4	22.3	-18.9	34.8	46.0	55.0	200

Table 7-2-12. Ch.6 (5875MHz) **RX** mode

Frequency (MHz)	Polarity (H/V)	Measured (dBμV)	Antenna Factor (dB/m)	Corr. Factor (dB)	Field Strength (dBμV/m)	Limit (dBμV/m)	Field Strength (μV/m)	Limit (μV/m)
61.966	V	51.6	9.1	-28.6	32.1	40.0	40.3	100
386.574	V	46.6	14.9	-23.1	38.4	46.0	83.2	200
452.189	V	40.6	16.5	-21.9	35.2	46.0	57.5	200
465.379	V	40.8	16.8	-21.8	35.8	46.0	61.7	200
662.431	V	33.8	20.4	-20.4	33.8	46.0	49.0	200
862.247	H	31.2	22.3	-18.9	34.6	46.0	53.7	200

8. Restricted Bands Radiatio (1GHz – 40GHz)

[FCC 15.205 / 209, RSS-210 6.3 / 7.3]

8.1 Test Procedure

Radiated emissions were measured in the frequency range with 1 GHz to 40GHz in transmitting mode and 1 GHz to 25GHz in receiving mode. All tests were performed in the semi-anechoic chamber at a 3-meter distance (except for the frequency range with 18 GHz to 40 GHz where test distance was reduced to 1 meter) on both horizontal and vertical polarities. The antenna was also scanned in height. The emissions are recorded with a spectrum analyzer in peak hold mode. The identified emissions are further maximized as a function of cable manipulation, azimuth, and antenna height. The emissions closest to the limits are measured in the peak mode with the tuned spectrum analyzer using resolution bandwidth of 1MHz / video bandwidth of 1MHz, and the average setting mode with the tuned spectrum analyzer using resolution bandwidth of 1MHz / video bandwidth of 100Hz or 10Hz. The highest emissions relative to the limit are listed.

8.2 Test Instruments and Measurement Setup

Table 8 Radiated Emission Test Instrumentation (1GHz – 40GHz)

Description	Model	Serial Number
Spectrum Analyzer EMI Test Receiver	R&S ESI26	836119/003
Spectrum Analyzer	HP 8563E	3416A02248
Harmonic Mixer (26.5 – 40GHz)	Agilent 11970A	011269-001
Amplifier (1 - 18GHz)	HP 8449B	3008A00582
Amplifier (18 – 40GHz)	Agilent 83051A	3950M00193
Horn Antenna (1 - 18GHz)	EMCO 3115	9903-5774
Horn Antenna (3.95 – 5.85GHz)	EMCO 3160-5	1099
Horn Antenna (5.85 – 8.2GHz)	EMCO 3160-6	9712-1044
Horn Antenna (8.2 – 12.4GHz)	EMCO 3160-7	1156
Horn Antenna (12.4 – 18GHz)	EMCO 3160-8	1143
Horn Antenna (18 - 26.5GHz)	EMCO 3160-9	0004-1202
Horn Antenna (26.5 - 40GHz)	EMCO 3160-10	1175
Coaxial cables:	Length:	
- Horn Ant <=> RF Amp. (1-18GHz)	6 m	- EM206SCO
- RF Amp. <=> Spectrum Analyzer (1-12.4GHz)	16 m	- GEM0101
- RF Amp. <=> Spectrum Analyzer (12.4-18GHz)	3m	- SF102-20166
- Horn Ant <=> RF Amp. (18-40GHz)	3m	- SF102-20167
- RF Amp. <=> Spectrum Analyzer (18-40GHz)	1m	- SF102-21105

Notes: - HP: Hewlett Packard, R&S: Rohde & Schwarz

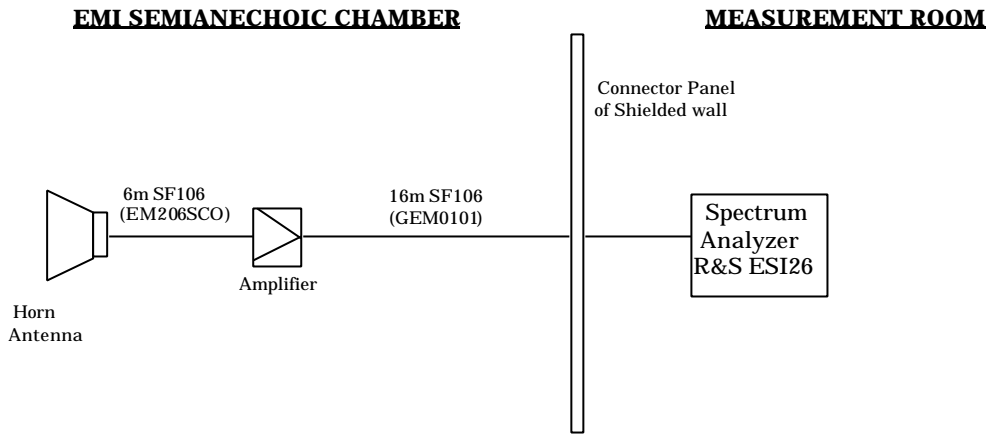

Figure 8-1. Cables for Radiated Emission Test (1 – 12.4 GHz)

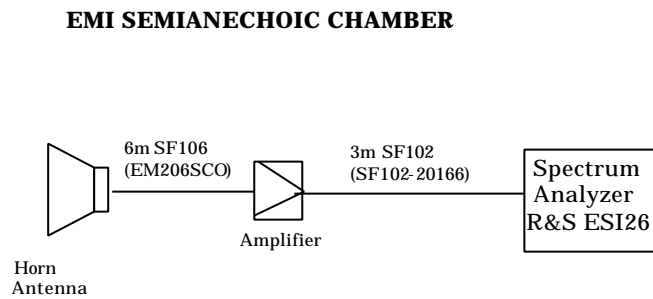

Figure 8-2. Cables for Radiated Emission Test (12.4 - 18GHz)

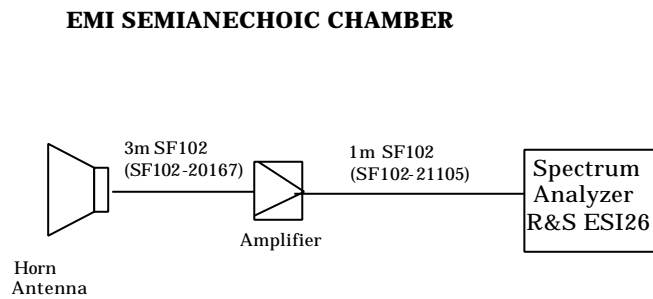

Figure 8-3. Cables for Radiated Emission Test (18 - 25GHz)

EMI SEMIANECHOIC CHAMBER

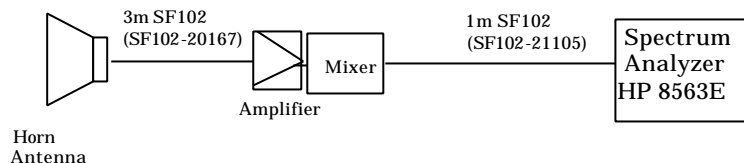

Figure 8-4. Cables for Radiated Emission Test (26.5 - 40GHz)

8.3 Field Strength Calculation

The field strength is calculated by adding the Antenna Factor and Cable Loss, and subtracting Amplifier Gain from the measured reading. All factors are included in the reported data.

$$FS = R + AF + CORR - FO$$

where:

- FS = Field Strength
- R = Measured Spectrum analyzer Input Amplitude
- AF = Antenna Factor
- CORR= Correction Factor = CL-AG
- CL = Cable Loss
- AG = Amplifier Gain
- FO = Distance Falloff Factor

For example:
 Given a Spectrum Analyzer input reading of 51.5 dBμV; Antenna Factor of 8.5 dB/m; Cable Loss of 1.3 dB; Falloff Factor of 0 dB; and an Amplifier Gain of 26 dB. The Field Strength of the measured emission is:

$$FS = 51.5 + 8.5 + 1.3 - 26 - 0.0 = 35.6 \text{ dB}\mu\text{V/m}$$

Conversions between dBμV/m (or dBμV) and μV/m (or μV) are done as :

$$\begin{aligned} \text{Level(dB}\mu\text{V/m)} &= 20 \times \text{Log (Level(}\mu\text{V/m))} \\ 40 \text{ dB}\mu\text{V/m} &= 100 \mu\text{V/m} \\ 48 \text{ dB}\mu\text{V/m} &= 250 \mu\text{V/m} \end{aligned}$$

8.4 Measurement Results

The EUT was found to comply to the limits of FCC Part 15 Subpart C and RSS-210 with a margin of 4.4 dB. The measurement was done for the frequency range of 1 GHz to 40 GHz in TX mode and 1 GHz to 25GHz in RX mode.

Test Date: July 13, 14 and 15, 2004

8.4.1 EUT in 2.4GHz DSSS transmission mode

*Note: OB means “operation band” (2400-2483.5MHz); in this case limit is 1W (measured conducted with power meter)

The actual highest emissions were found on the auxiliary antenna of ThinkPad G40 Series, LCD 14 inch model.

Table 8-2-1. Ch.1 (2412MHz) TX mode 11Mbps

Frequency (GHz)	Polarity (H/V)	Measured (dBμV) (peak)	Measured (dBμV) (average)	Antenna Factor (dB/m)	Corr. Factor (dB)	Falloff Factor (dB)	Field Strength (dBμV/m) (peak)	FCC Limit (dBμV/m) (peak)	Field Strength (dBμV/m) (average)	FCC Limit (dBμV/m) (average)
Inband 2.414	H	111.7	103.0	28.3	-29.1	0.0	110.9	OB*	102.2	OB*
Adjacent RB 2.383	H	62.4	44.6	28.2	-29.2	0.0	61.4	74.0	43.6	54.0
2.387	H	64.2	46.6	28.2	-29.2	0.0	63.2	74.0	45.6	54.0
2.390	H	65.6	45.8	28.2	-29.2	0.0	64.6	74.0	44.8	54.0
1.128	V	56.4	-	24.5	-31.5	0.0	49.4	74.0	-	54.0
1.161	V	58.3	-	24.6	-31.3	0.0	51.6	74.0	-	54.0
1.327	V	58.4	-	25.6	-31.0	0.0	53.0	74.0	-	54.0
1.664	V	54.1	-	25.6	-30.3	0.0	49.4	74.0	-	54.0
2.361	V	53.6	-	28.1	-29.2	0.0	52.5	74.0	-	54.0
2.376	V	53.2	-	28.2	-29.2	0.0	52.2	74.0	-	54.0
4.826	H	66.9	28.9	27.1	-26.6	0.0	67.4	74.0	29.4	54.0

Table 8-2-2. Ch.6 (2437MHz) TX mode 11Mbps

Frequency (GHz)	Polarity (H/V)	Measured (dBμV) (peak)	Measured (dBμV) (average)	Antenna Factor (dB/m)	Corr. Factor (dB)	Falloff Factor (dB)	Field Strength (dBμV/m) (peak)	FCC Limit (dBμV/m) (peak)	Field Strength (dBμV/m) (average)	FCC Limit (dBμV/m) (average)
Inband 2.438	H	112.0	104.0	28.4	-29.2	0.0	111.2	OB*	103.2	OB*
Adjacent RB 2.380	H	64.0	43.2	28.2	-29.2	0.0	63.0	74.0	42.2	54.0
2.390	H	62.6	43.3	28.2	-29.2	0.0	61.6	74.0	42.3	54.0
2.484	H	51.4	-	28.4	-29.1	0.0	50.7	74.0	-	54.0
1.128	V	54.6	-	24.5	-31.5	0.0	47.6	74.0	-	54.0
1.163	V	59.6	-	24.6	-31.3	0.0	52.9	74.0	-	54.0
1.330	V	60.0	39.4	25.6	-31.0	0.0	54.6	74.0	34.0	54.0
1.664	V	53.7	-	25.6	-30.3	0.0	49.0	74.0	-	54.0
2.346	V	53.2	-	28.1	-29.3	0.0	52.0	74.0	-	54.0
2.361	V	53.0	-	28.1	-29.2	0.0	51.9	74.0	-	54.0
2.364	V	52.8	-	28.1	-29.2	0.0	51.7	74.0	-	54.0
4.876	H	63.4	31.3	27.0	-26.6	0.0	63.8	74.0	31.7	54.0
7.308	V	45.8	-	29.9	-24.4	0.0	51.3	74.0	-	54.0

Table 8-2-3. Ch.11 (2462MHz) TX mode 11Mbps

Frequency (GHz)	Polarity (H/V)	Measured (dBμ V) (peak)	Measured (dBμ V) (average)	Antenna Factor (dB/m)	Corr. Factor (dB)	Falloff Factor (dB)	Field Strength (dBμ V/m) (peak)	FCC Limit (dBμ V/m) (peak)	Field Strength (dBμ V/m) (average)	FCC Limit (dBμ V/m) (average)
Inband 2.460	H	109.6	102.5	28.4	-29.2	0.0	108.8	OB*	101.7	OB*
Adjacent RB 2.484	H	59.5	41.6	28.4	-29.1	0.0	58.8	74.0	40.9	54.0
2.489	H	53.6	43.2	28.4	-29.1	0.0	52.9	74.0	42.5	54.0
1.126	V	54.9	-	24.5	-31.5	0.0	47.9	74.0	-	54.0
1.160	V	58.3	-	24.6	-31.3	0.0	51.6	74.0	-	54.0
1.330	V	63.3	39.3	25.6	-31.0	0.0	57.9	74.0	33.9	54.0
1.664	V	53.2	-	25.6	-30.3	0.0	48.5	74.0	-	54.0
2.350	H	52.5	-	28.1	-29.3	0.0	51.3	74.0	-	54.0
2.361	H	55.9	42.9	28.1	-29.2	0.0	54.8	74.0	41.8	54.0
2.377	H	58.9	42.6	28.2	-29.2	0.0	57.9	74.0	41.6	54.0
2.389	H	54.0	-	28.2	-29.2	0.0	53.0	74.0	-	54.0
4.926	H	65.9	33.0	27.0	-26.4	0.0	66.5	74.0	33.6	54.0
7.386	H	42.8	-	29.8	-24.7	0.0	47.9	74.0	-	54.0

Table 8-2-4. Ch.6 (2437MHz) RX mode

Frequency (GHz)	Polarity (H/V)	Measured (dBμ V) (peak)	Measured (dBμ V) (average)	Antenna Factor (dB/m)	Corr. Factor (dB)	Falloff Factor (dB)	Field Strength (dBμ V/m) (peak)	FCC Limit (dBμ V/m) (peak)	Field Strength (dBμ V/m) (average)	FCC Limit (dBμ V/m) (average)
1.128	V	54.1	-	24.5	-31.5	0.0	47.1	74.0	-	54.0
1.164	V	57.0	-	24.6	-31.3	0.0	50.3	74.0	-	54.0
1.328	V	56.1	-	25.6	-31.0	0.0	50.7	74.0	-	54.0
1.665	V	54.9	-	25.6	-30.3	0.0	50.2	74.0	-	54.0

8.4.2 EUT in 2.4GHz OFDM transmission mode

*Note: OB means “operation band” (2400-2483.5MHz); in this case limit is 1W (measured conducted with power meter)

The actual highest emissions were found on the auxiliary antenna of ThinkPad G40 Series, LCD 14 inch model.

Table 8-2-5. Ch.1 (2412MHz) **TX** mode 6Mbps

Frequency (GHz)	Polarity (H/V)	Measured (dBμV) (<i>peak</i>)	Measured (dBμV) (<i>average</i>)	Antenna Factor (dB/m)	Corr. Factor (dB)	Falloff Factor (dB)	Field Strength (dBμV/m) (<i>peak</i>)	FCC Limit (dBμV/m) (<i>peak</i>)	Field Strength (dBμV/m) (<i>average</i>)	FCC Limit (dBμV/m) (<i>average</i>)
Inband 2.416	H	108.7	97.9	28.3	-29.1	0.0	107.9	OB*	97.1	OB*
Adjacent RB 2.389	H	69.1	47.3	28.2	-29.2	0.0	68.1	74.0	46.3	54.0
2.390	H	70.6	49.5	28.2	-29.2	0.0	69.6	74.0	48.5	54.0
1.128	V	57.0	-	24.5	-31.5	0.0	50.0	74.0	-	54.0
1.164	V	62.5	38.6	24.6	-31.3	0.0	55.8	74.0	31.9	54.0
1.327	V	57.2	-	25.6	-31.0	0.0	51.8	74.0	-	54.0
1.664	V	53.4	-	25.6	-30.3	0.0	48.7	74.0	-	54.0
2.369	V	52.3	-	28.1	-29.2	0.0	51.2	74.0	-	54.0
2.383	V	55.2	39.1	28.2	-29.2	0.0	54.2	74.0	38.1	54.0
2.386	V	56.9	39.7	28.2	-29.2	0.0	55.9	74.0	38.7	54.0
4.828	H	58.2	29.8	27.1	-26.6	0.0	58.7	74.0	30.3	54.0

Table 8-2-6. Ch.6 (2437MHz) **TX** mode 6Mbps

Frequency (GHz)	Polarity (H/V)	Measured (dBμV) (<i>peak</i>)	Measured (dBμV) (<i>average</i>)	Antenna Factor (dB/m)	Corr. Factor (dB)	Falloff Factor (dB)	Field Strength (dBμV/m) (<i>peak</i>)	FCC Limit (dBμV/m) (<i>peak</i>)	Field Strength (dBμV/m) (<i>average</i>)	FCC Limit (dBμV/m) (<i>average</i>)
Inband 2.432	H	111.3	100.8	28.4	-29.2	0.0	110.5	OB*	100.0	OB*
Adjacent RB 2.388	H	55.7	43.0	28.2	-29.2	0.0	54.7	74.0	42.0	54.0
2.390	H	54.4	-	28.2	-29.2	0.0	53.4	74.0	-	54.0
2.484	H	49.1	-	28.4	-29.1	0.0	48.4	74.0	-	54.0
1.126	V	56.1	-	24.5	-31.5	0.0	49.1	74.0	-	54.0
1.160	V	59.6	-	24.6	-31.3	0.0	52.9	74.0	-	54.0
1.327	V	60.8	39.6	25.6	-31.0	0.0	55.4	74.0	34.2	54.0
1.662	V	53.3	-	25.6	-30.3	0.0	48.6	74.0	-	54.0
2.355	H	53.5	-	28.1	-29.2	0.0	52.4	74.0	-	54.0
2.361	H	54.5	-	28.1	-29.2	0.0	53.4	74.0	-	54.0
2.378	H	52.8	-	28.2	-29.2	0.0	51.8	74.0	-	54.0
2.387	H	53.4	-	28.2	-29.2	0.0	52.4	74.0	-	54.0
4.874	V	63.8	32.0	27.0	-26.6	0.0	64.2	74.0	32.4	54.0
7.314	V	56.0	36.7	29.8	-24.4	0.0	61.4	74.0	42.1	54.0

Table 8-2-7. Ch.11 (2462MHz) **TX** mode 6Mbps

Frequency (GHz)	Polarity (H/V)	Measured (dB μ V) (<i>peak</i>)	Measured (dB μ V) (<i>average</i>)	Antenna Factor (dB/m)	Corr. Factor (dB)	Falloff Factor (dB)	Field Strength (dB μ V/m) (<i>peak</i>)	FCC Limit (dB μ V/m) (<i>peak</i>)	Field Strength (dB μ V/m) (<i>average</i>)	FCC Limit (dB μ V/m) (<i>average</i>)
Inband 2.456	H	107.9	97.3	28.4	-29.2	0.0	107.1	OB*	96.5	OB*
Adjacent RB 2.484	H	62.1	43.4	28.4	-29.1	0.0	61.4	74.0	42.7	54.0
2.485	H	60.8	41.2	28.4	-29.1	0.0	60.1	74.0	40.5	54.0
1.126	V	55.5	-	24.5	-31.5	0.0	48.5	74.0	-	54.0
1.166	V	51.1	-	24.6	-31.3	0.0	44.4	74.0	-	54.0
1.324	V	58.6	-	25.6	-31.0	0.0	53.2	74.0	-	54.0
1.662	V	52.8	-	25.6	-30.3	0.0	48.1	74.0	-	54.0
2.355	H	53.4	-	28.1	-29.2	0.0	52.3	74.0	-	54.0
2.362	H	54.9	-	28.1	-29.2	0.0	53.8	74.0	-	54.0
2.369	H	54.6	-	28.1	-29.2	0.0	53.5	74.0	-	54.0
2.384	H	55.3	41.8	28.2	-29.2	0.0	54.3	74.0	40.8	54.0
4.914	H	57.8	30.6	27.0	-26.4	0.0	58.4	74.0	31.2	54.0
7.380	V	42.3	-	29.8	-24.5	0.0	47.6	74.0	-	54.0

Table 8-2-8. Ch.6 (2437MHz) **RX** mode

Frequency (GHz)	Polarity (H/V)	Measured (dB μ V) (<i>peak</i>)	Measured (dB μ V) (<i>average</i>)	Antenna Factor (dB/m)	Corr. Factor (dB)	Falloff Factor (dB)	Field Strength (dB μ V/m) (<i>peak</i>)	FCC Limit (dB μ V/m) (<i>peak</i>)	Field Strength (dB μ V/m) (<i>average</i>)	FCC Limit (dB μ V/m) (<i>average</i>)
1.128	V	52.7	-	24.5	-31.5	0.0	45.7	74.0	-	54.0
1.160	V	53.8	-	24.6	-31.3	0.0	47.1	74.0	-	54.0
1.330	V	56.4	-	25.6	-31.0	0.0	51.0	74.0	-	54.0
1.662	V	52.3	-	25.6	-30.3	0.0	47.6	74.0	-	54.0

8.4.3 EUT in 5.8GHz OFDM transmission mode

*Note: OB means “operation band” (5725-5850MHz); in this case limit is 1W (measured conducted with power meter)

The actual highest emissions were found on the main antenna of ThinkPad G40 Series, LCD 14 inch model.

Table 8-2-9. Ch.149 (5745MHz) **TX** mode 6Mbps

Frequency (GHz)	Polarity (H/V)	Measured (dBμV) (peak)	Measured (dBμV) (average)	Antenna Factor (dB/m)	Corr. Factor (dB)	Falloff Factor (dB)	Field Strength (dBμV/m) (peak)	FCC Limit (dBμV/m) (peak)	Field Strength (dBμV/m) (average)	FCC Limit (dBμV/m) (average)
Inband										
5.747	V	101.0	90.3	34.0	-25.6	0.0	109.4	OB*	98.7	OB*
1.104	V	56.8	-	24.4	-31.5	0.0	49.7	74.0	-	54.0
1.160	V	62.0	38.2	24.6	-31.3	0.0	55.3	74.0	31.5	54.0
1.326	V	58.4	-	25.6	-31.0	0.0	53.0	74.0	-	54.0
1.661	V	53.6	-	25.6	-30.3	0.0	48.9	74.0	-	54.0
11.487	V	47.9	33.3	33.5	-19.9	0.0	61.5	74.0	46.9	54.0
22.973	V	43.1	29.5	40.7	-18.4	9.5	55.9	74.0	51.8	54.0

Table 8-2-10 Ch.157 (5785MHz) **TX** mode 6Mbps

Frequency (GHz)	Polarity (H/V)	Measured (dBμV) (peak)	Measured (dBμV) (average)	Antenna Factor (dB/m)	Corr. Factor (dB)	Falloff Factor (dB)	Field Strength (dBμV/m) (peak)	FCC Limit (dBμV/m) (peak)	Field Strength (dBμV/m) (average)	FCC Limit (dBμV/m) (average)
Inband										
5.787	H	101.5	91.3	34.0	-25.5	0.0	110.0	OB*	99.8	OB*
1.126	V	54.5	-	24.5	-31.5	0.0	47.5	74.0	-	54.0
1.160	V	57.1	-	24.6	-31.3	0.0	50.4	74.0	-	54.0
1.329	V	62.2	39.3	25.6	-31.0	0.0	56.8	74.0	33.9	54.0
1.529	V	53.6	-	25.6	-30.3	0.0	48.9	74.0	-	54.0
11.569	V	46.6	30.1	33.5	-19.7	0.0	60.4	74.0	43.9	54.0

Table 8-2-11 EUT: Ch.165 (5825MHz) **TX** mode 6Mbps

Frequency (GHz)	Polarity (H/V)	Measured (dBμV) (peak)	Measured (dBμV) (average)	Antenna Factor (dB/m)	Corr. Factor (dB)	Falloff Factor (dB)	Field Strength (dBμV/m) (peak)	FCC Limit (dBμV/m) (peak)	Field Strength (dBμV/m) (average)	FCC Limit (dBμV/m) (average)
Inband										
5.822	H	100.7	90.3	34.0	-25.6	0.0	109.1	OB*	98.7	OB*
1.102	V	53.2	-	24.4	-31.5	0.0	46.1	74.0	-	54.0
1.160	V	58.5	-	24.6	-31.3	0.0	51.8	74.0	-	54.0
1.327	V	63.8	38.8	25.6	-31.0	0.0	58.4	74.0	33.4	54.0
1.525	V	53.2	-	25.6	-30.3	0.0	48.5	74.0	-	54.0
11.647	V	44.5	32.6	33.6	-20.0	0.0	58.1	74.0	46.2	54.0

Table 8-2-12 Ch.157 (5785MHz) **RX** mode

Frequency (GHz)	Polarity (H/V)	Measured (dBμV) (peak)	Measured (dBμV) (average)	Antenna Factor (dB/m)	Corr. Factor (dB)	Falloff Factor (dB)	Field Strength (dBμV/m) (peak)	FCC Limit (dBμV/m) (peak)	Field Strength (dBμV/m) (average)	FCC Limit (dBμV/m) (average)
1.126	V	53.1	-	24.5	-31.5	0.0	46.1	74.0	-	54.0
1.164	V	57.3	-	24.6	-31.3	0.0	50.6	74.0	-	54.0
1.327	V	56.5	-	25.6	-31.0	0.0	51.1	74.0	-	54.0
1.529	V	53.0	-	25.6	-30.3	0.0	48.3	74.0	-	54.0

8.5 Measurement plots of adjacent restricted band

8.5.1 List of Measurement Results

The measurement was performed with the worse cases of each transmission mode that tend to have higher peak output power based on the results of previous Chapter 3 “Conducted Peak Output Power” measurement. (i.e. 11Mbps for DSSS, and 6Mbps for OFDM.)

And each host device with the higher antenna gain was selected for each transmission mode.

Table 8-3-1. Radiated peak emission in 2.4GHz DSSS transmission mode, 11Mbps

Measured host device: IBM ThinkPad G40 Series, auxiliary antenna

Host device	Frequency (GHz)	Polarity (H/V)	Reading (dBμV) (peak)	Rading (dBμV) (average)	Antenna Factor (dB/m)	Corr. Factor (dB)	Falloff Factor (dB)	Field Strength (dBμV/m) (peak)	Margin to Limit (dBμV/m) (peak)	Field Strength (dBμV/m) (average)	Margin to Limit (dBμV/m) (average)
G40 14"	2.387	H	64.2	46.6	28.2	-29.2	0.0	63.2	10.8	45.6	8.4
	2.484	H	59.5	41.6	28.4	-29.1	0.0	58.8	15.2	40.9	13.1
G40 15"	2.388	H	61.9	46.5	28.2	-29.2	0.0	60.9	13.1	45.5	8.5
	2.493	H	53.3	-	28.4	-29.1	0.0	52.6	21.4	-	-

Table 8-3-2. Radiated peak emission in 2.4GHz OFDM transmission mode, 6Mbps

Measured host device: IBM ThinkPad G40 Series, auxiliary antenna

Host device	Frequency (GHz)	Polarity (H/V)	Reading (dBμV) (peak)	Rading (dBμV) (average)	Antenna Factor (dB/m)	Corr. Factor (dB)	Falloff Factor (dB)	Field Strength (dBμV/m) (peak)	Margin to Limit (dBμV/m) (peak)	Field Strength (dBμV/m) (average)	Margin to Limit (dBμV/m) (average)
G40 14"	2.390	H	70.6	49.5	28.2	-29.2	0.0	69.6	4.4	48.5	5.5
	2.484	H	62.1	43.4	28.4	-29.1	0.0	61.4	12.6	42.7	11.3
G40 15"	2.389	H	70.1	47.0	28.2	-29.2	0.0	69.1	4.9	46.0	8.0
	2.484	H	60.6	42.6	28.4	-29.1	0.0	59.9	14.1	41.9	12.1

Table 8-3-3. Radiated peak emission in 5.8GHz OFDM transmission mode, 6Mbps (References only since there is no restricted band near 5.8GHz band.)

Measured host device: IBM ThinkPad G40 Series, main antenna

Host device	Frequency (GHz)	Polarity (H/V)	Reading (dBμV) (peak)	Rading (dBμV) (average)	Antenna Factor (dB/m)	Corr. Factor (dB)	Falloff Factor (dB)	Field Strength (dBμV/m) (peak)	Field Strength (dBμV/m) (average)
G40 14"	5.785	H	101.5	91.3	34.0	-25.5	0.0	110.0	99.8
G40 15"	5.785	H	101.5	91.2	34.0	-25.5	0.0	110.0	99.7

8.5.2 Bandedge Measurement Plots

The plots are comparatively worse measurement cases of each transmission mode in the Table 8-3-1 through Table 8-3-3.

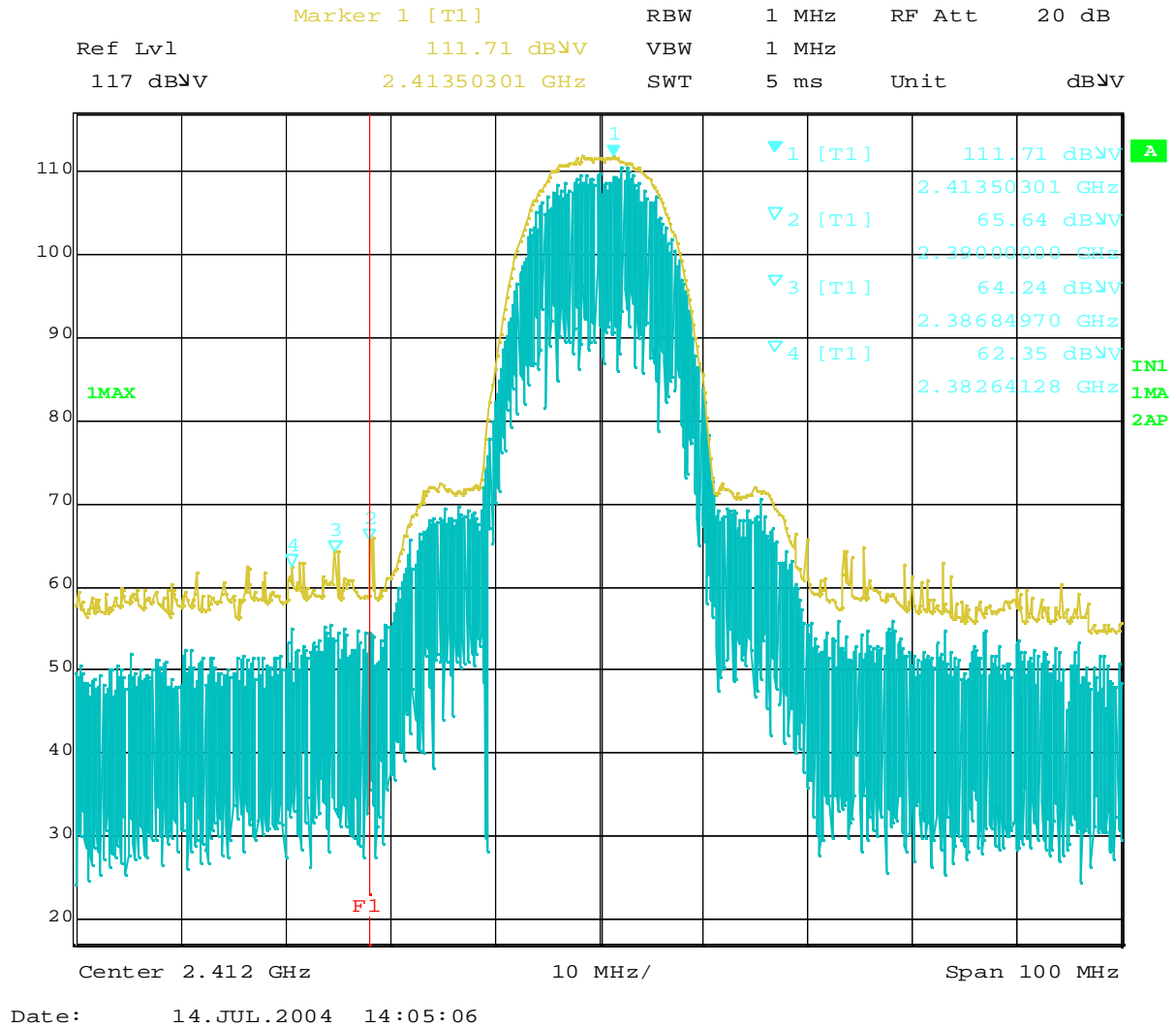

Plot 8-1 Ch.1 2412MHz TX, DSSS 11Mbps (Peak), 14" model

Marker 1 [T1] RBW 1 MHz RF Att 20 dB
 Ref Lvl 103.03 dBμV VBW 10 Hz
 117 dBμV 2.41290180 GHz SWT 25 s Unit dBμV

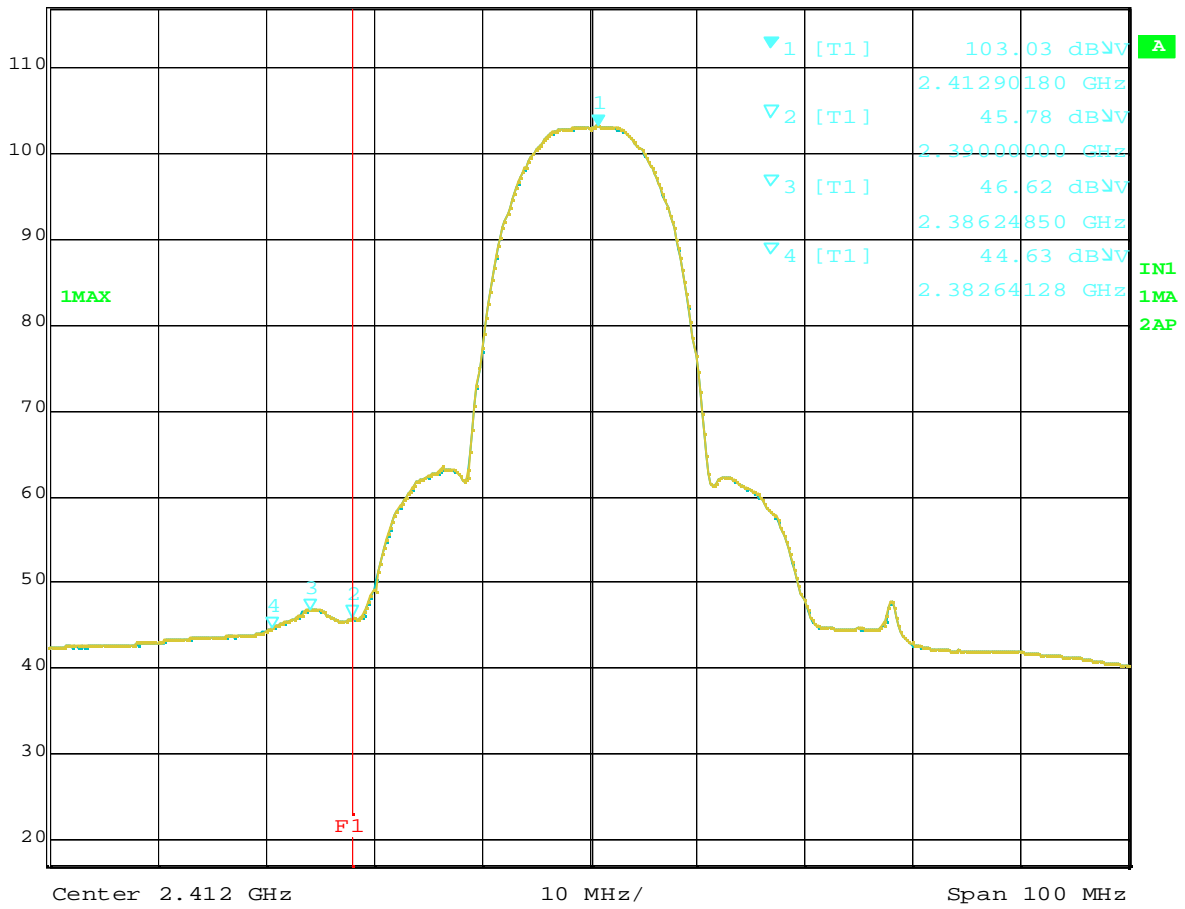

Date: 14.JUL.2004 14:07:32

Plot 8-2 Ch.1 2412MHz TX, DSSS 11Mbps (Average), 14" model

Marker 1 [T1] RBW 1 MHz RF Att 20 dB
 Ref Lvl 109.55 dBmV VBW 1 MHz
 117 dBmV 2.45989579 GHz SWT 5 ms Unit dBmV

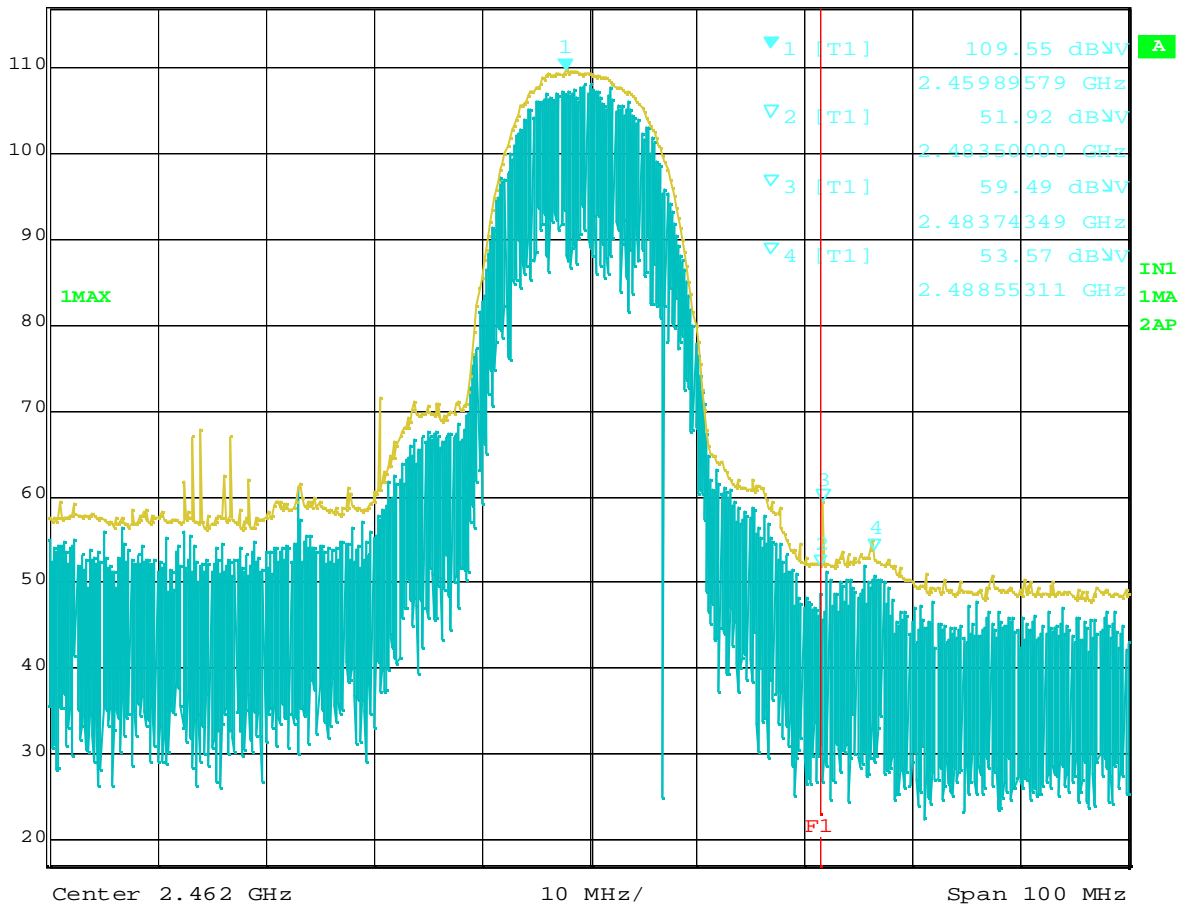

Date: 14.JUL.2004 14:14:49

Plot 8-3 Ch.11 2462MHz TX, DSSS 11Mbps (Peak), 14" mode

Marker 1 [T1] RBW 1 MHz RF Att 20 dB
 Ref Lvl 102.51 dBμV VBW 10 Hz
 117 dBμV 2.45969539 GHz SWT 25 s Unit dBμV

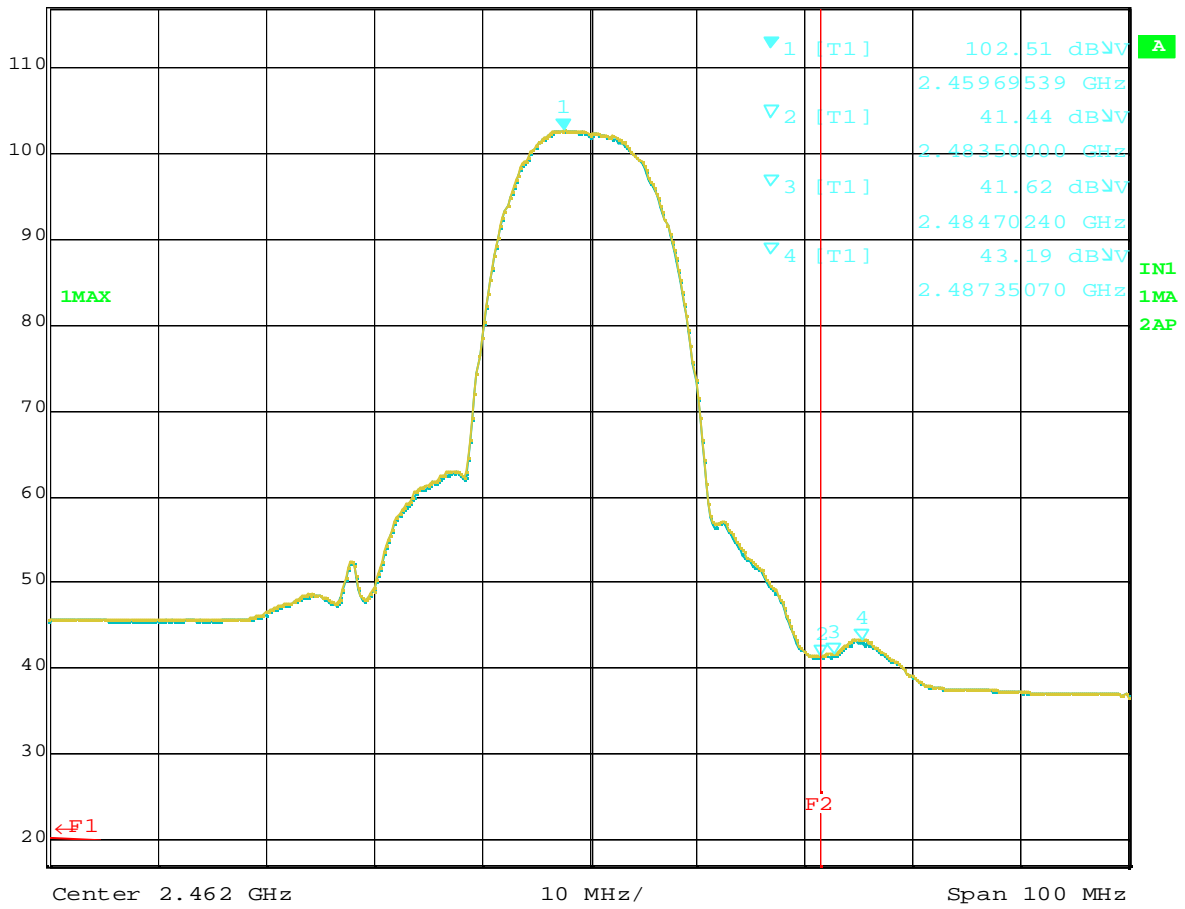

Plot 8-4 Ch.11 2462MHz TX, DSSS 11Mbps (Average), 14" model

Marker 1 [T1] RBW 1 MHz RF Att 20 dB
 Ref Lvl 108.69 dBμV VBW 1 MHz
 117 dBμV 2.41610822 GHz SWT 5 ms Unit dBμV

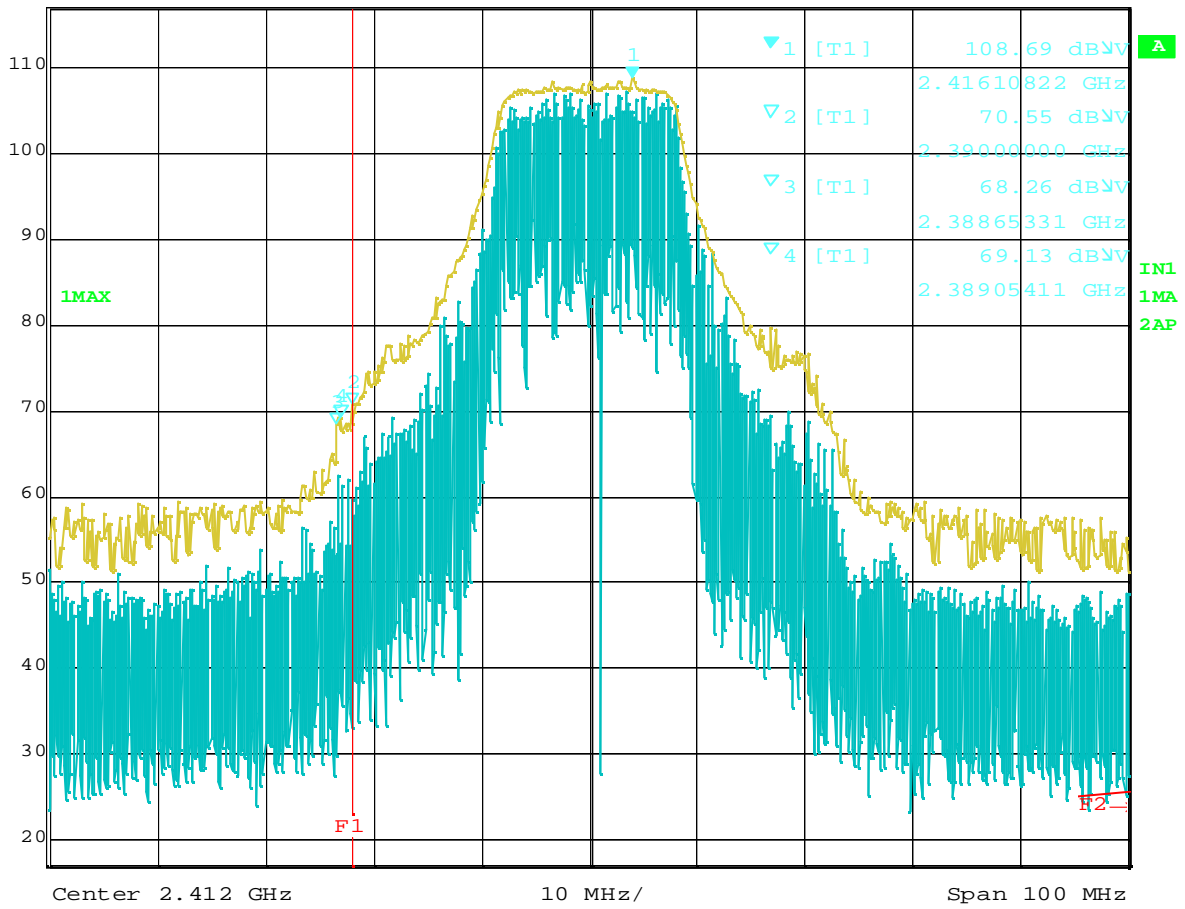

Date: 13.JUL.2004 16:35:37

Plot 8-5 Ch.1 2412MHz TX, OFDM 6Mbps (Peak), 14" model

Marker 1 [T1] RBW 1 MHz RF Att 20 dB
 Ref Lvl 97.85 dBmV VBW 10 Hz
 117 dBmV 2.41330261 GHz SWT 25 s Unit dBmV

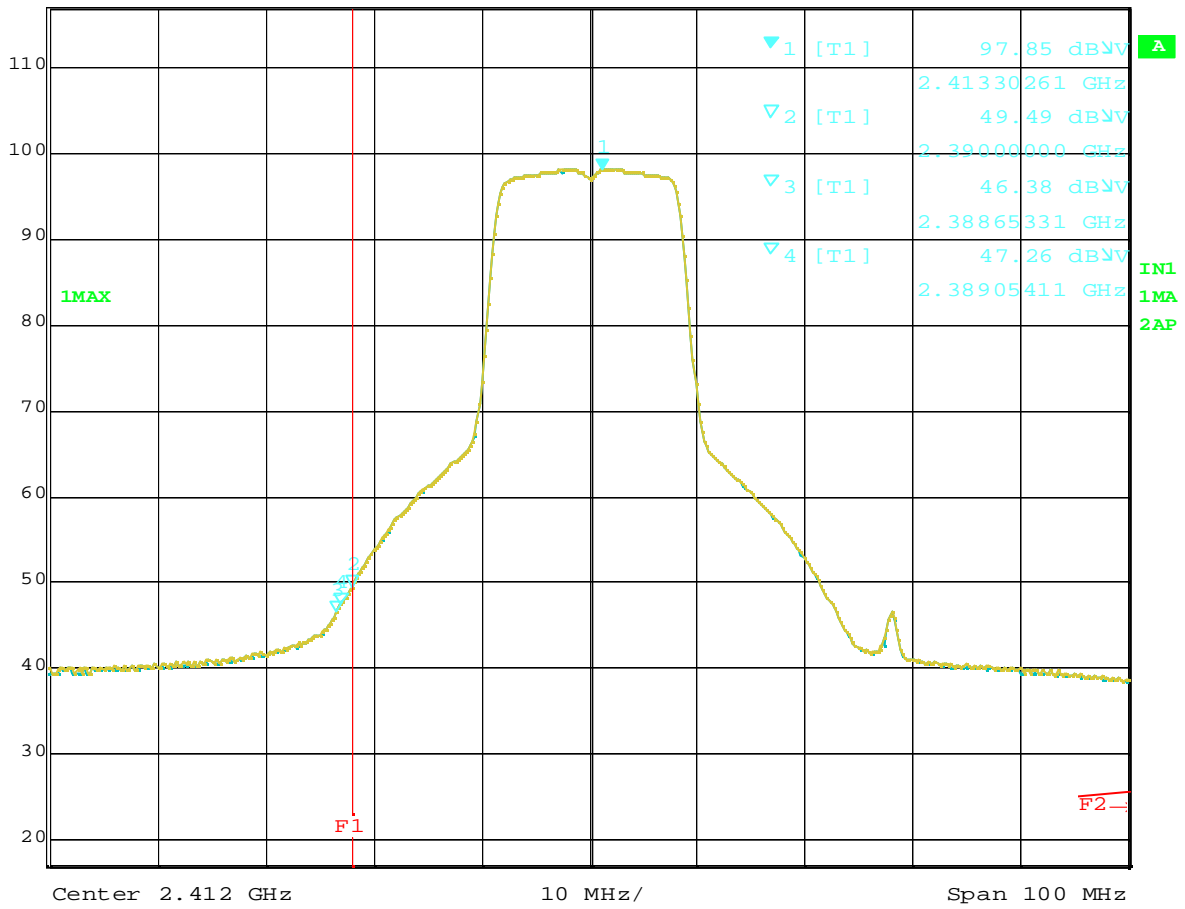

Date: 13.JUL.2004 16:36:53

Plot 8-6 Ch.1 2412MHz TX. OFDM 6Mbps (Average). 14" model

Marker 1 [T1] RBW 1 MHz RF Att 20 dB
 Ref Lvl 107.92 dBμV VBW 1 MHz
 117 dBμV 2.45568737 GHz SWT 5 ms Unit dBμV

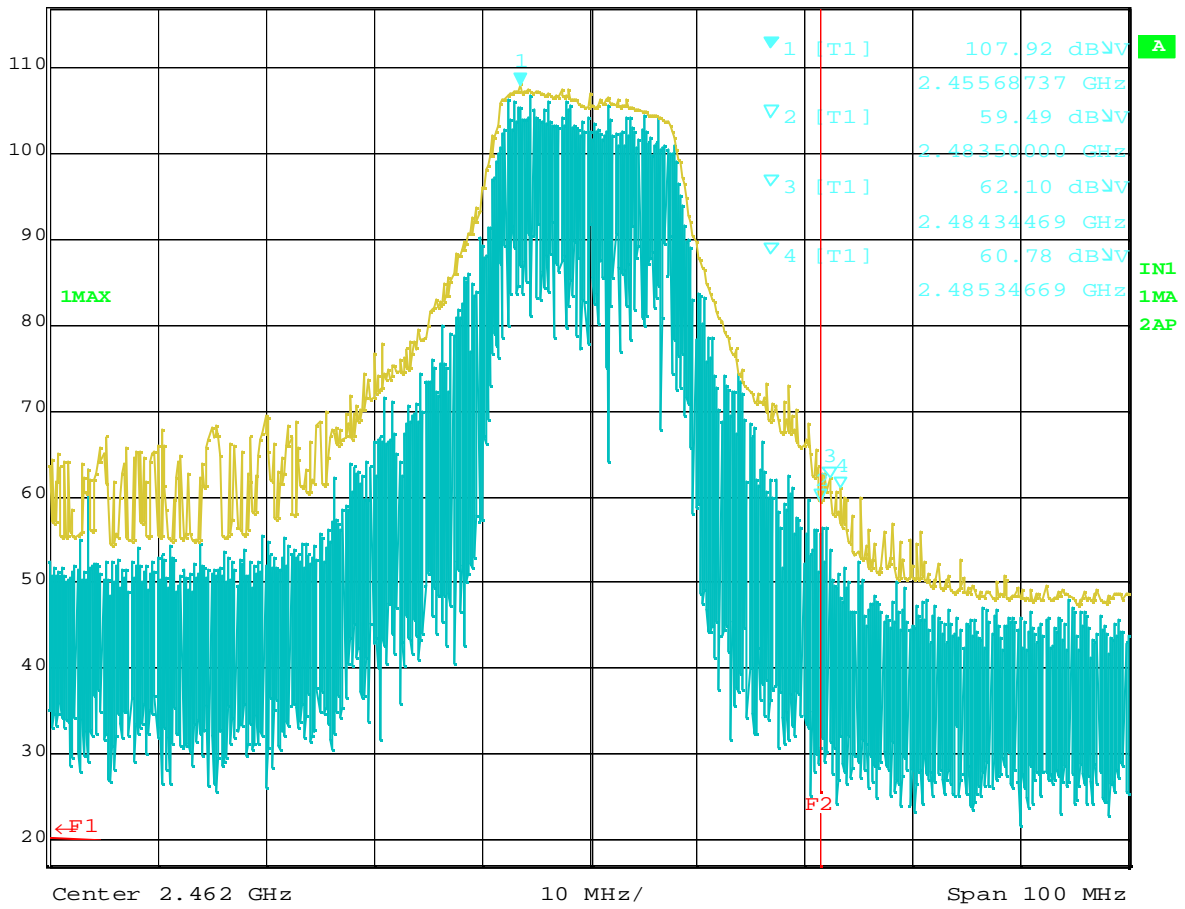

Date: 13.JUL.2004 16:38:15

Plot 8-7 Ch.11 2462MHz TX. OFDM 6Mbps (Peak). 14" model

Marker 1 [T1] RBW 1 MHz RF Att 20 dB
 Ref Lvl 97.34 dBμV VBW 10 Hz
 117 dBμV 2.45548697 GHz SWT 25 s Unit dBμV

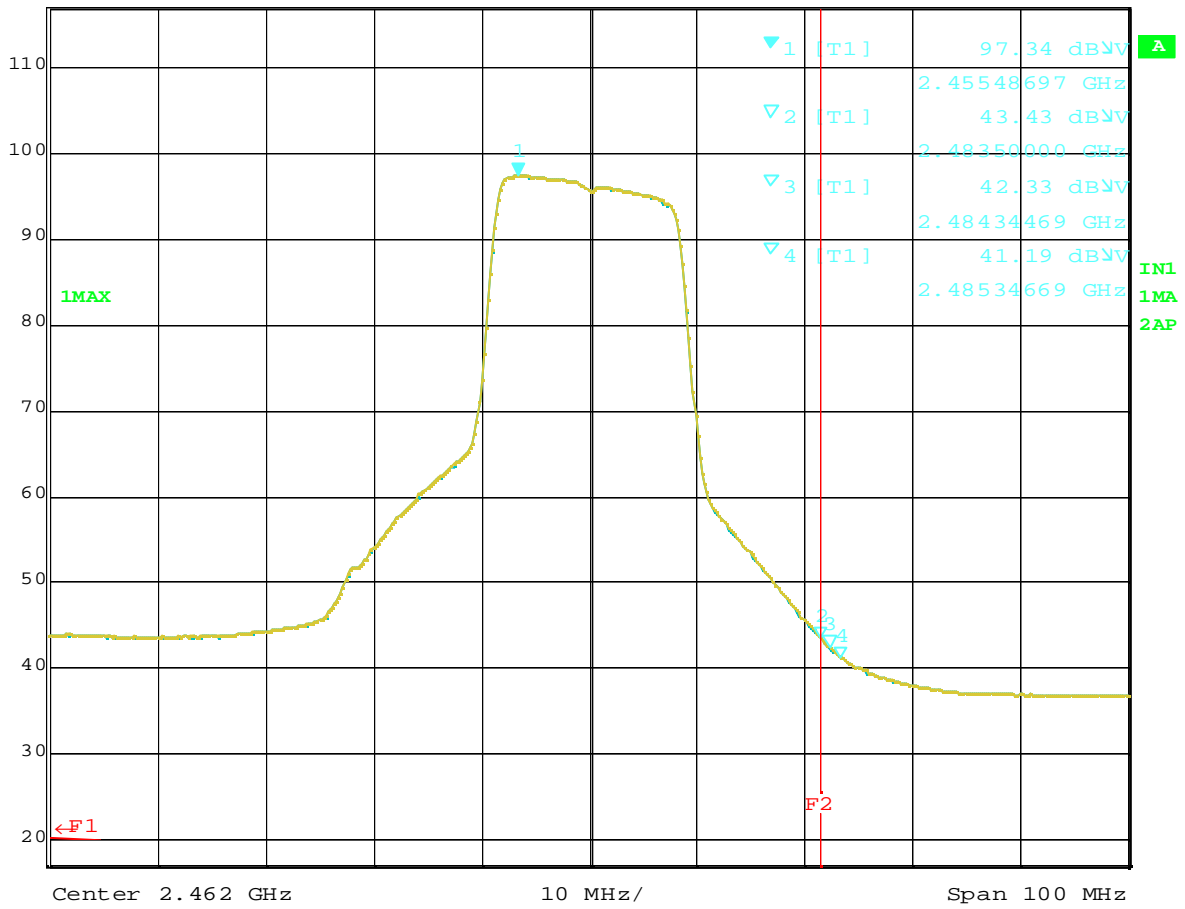

Date: 13.JUL.2004 16:39:23

Plot 8-8 Ch.11 2462MHz TX, OFDM 6Mbps (Average), 14" model