

4. BLOCK DIAGRAM OF EQUIPMENT

4.1 Block Diagram Description

Block diagram description is shown in figure 4.1 and figure 4.2.

Figure 4.1 Block Diagram Description of Basic Model KX-DP603 and KX-DP602

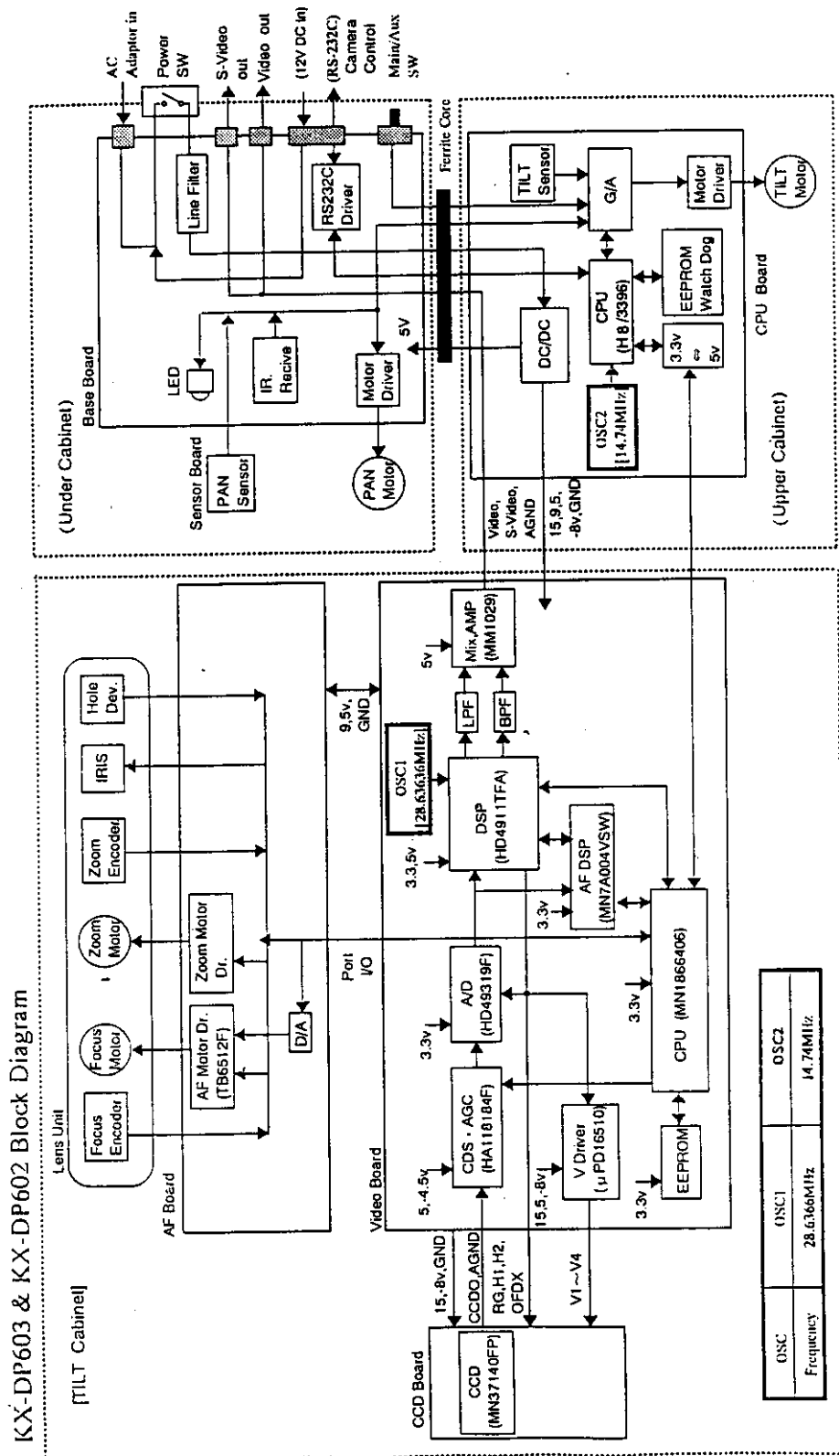

Figure 4.2 Block Diagram Description of Similar Model KX-DP601

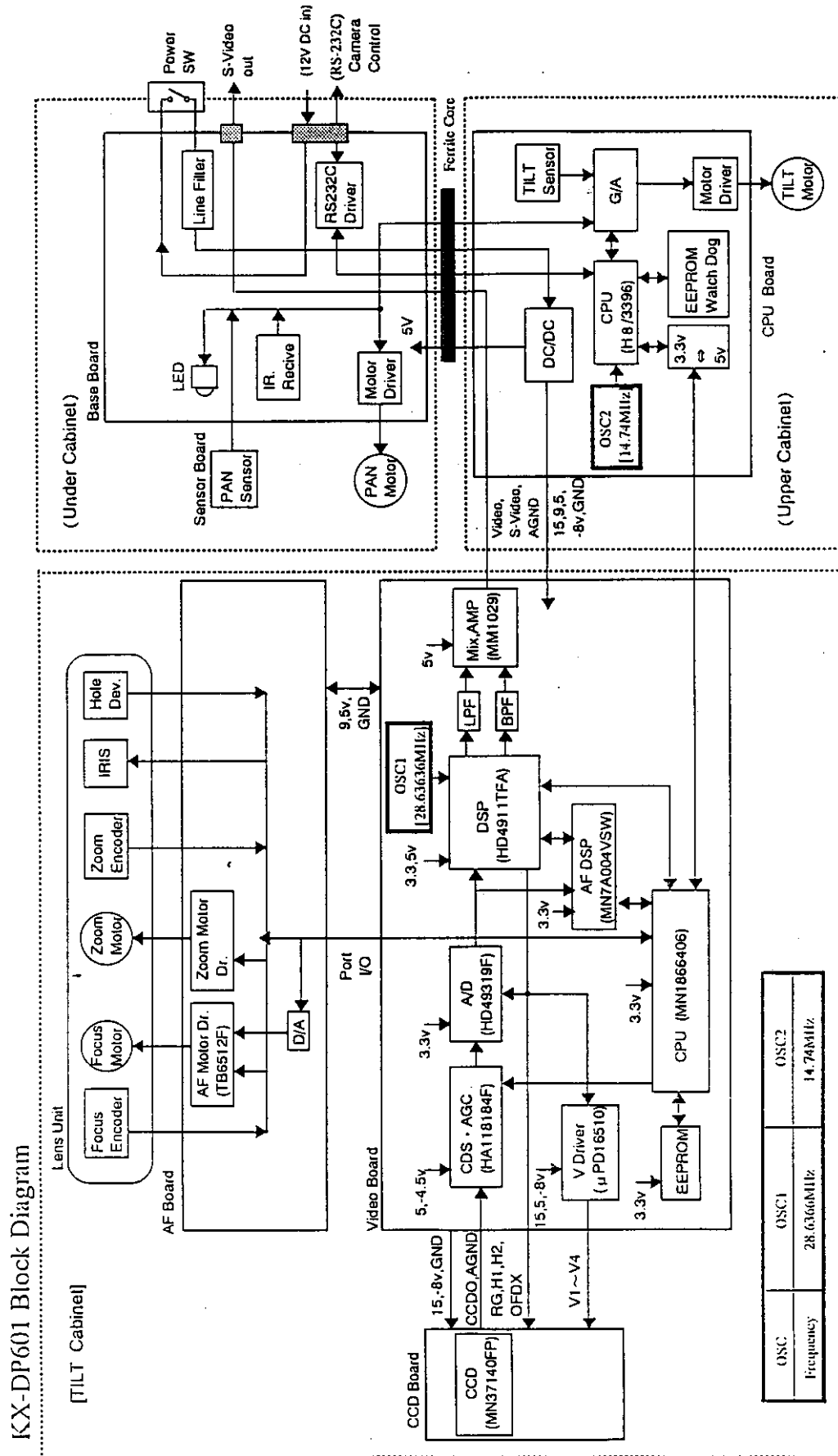

Figure 3.1 Configuration of Tested System

