

MEASUREMENT/TECHNICAL REPORT

MODEL JDWBL820

FCC ID : ACJKMKPSJDWBL820A

JULY 31, 1998

This report concerns: Original grant  Class II change \_\_\_\_\_  
Equipment type: Digital Device Peripheral/PC Card

Request issue of grant:

Immediately upon completion of review.  
 Defer grant per 47 CFR 0.457 (d)(1)(ii) until \_\_\_\_ date \_\_\_\_ .

Measurement procedure used:

ANSI C63.4-1992  FCC/OET MP-4(1987) \_\_\_\_\_ Other \_\_\_\_\_  
If other, describe \_\_\_\_\_

Application for Certification: FCC Rules and Regulations Part 15  
Subpart B

Prepared by:

Name: T. Hattori

Company name: Kyushu Matsushita Electric Co., Ltd.

Address: 1080 Takano Kikusui-machi, Yamana-gun Kumamoto  
865-0193, Japan

Phone number: +81-968-86-4837

FAX number : +81-968-86-3422

## Table of Contents

1. General Information
  - 1.1 Product Description
  - 1.2 Test System Details
  - 1.3 Test Methodology
  - 1.4 Test Facility
2. Product Labeling
  - Figure 2.1 FCC ID Label
  - Figure 2.2 Location of Label on EUT
3. System Test Configuration
  - 3.1 Justification
  - 3.2 Video Mode Justification
  - 3.3 EUT Exercise Software
  - 3.4 Special Accessories
  - 3.5 Configuration of Test System
4. Block Diagram of Equipment
  - 4.1 Block Diagram Description
    - Figure 4.1 Block Diagram of CD-ROM Player
5. CONDUCTED AND RADIATED MEASUREMENT PHOTOS
6. CONDUCTED EMISSION DATA
7. RADIATED EMISSION DATA
8. PHOTOS OF TESTED EUT
  - Figure 8.1 Top view of the EUT
  - Figure 8.2 Bottom view of the EUT
  - Figure 8.3 PC Board, component side
  - Figure 8.4 PC Board, foil side

Attachment A Measurement Report of Class B Digital Device

## 1 GENERAL INFORMATION

### 1.1 Product Description

The model PJWBL820A (referred to as the EUT in this report) is a PCMCIA Card for CD-ROM Player with SCSI interface. The EUT contains IC for SCSI control, Gate Array and Memory IC for PCMCIA control, term power control circuit, one oscilaters, and connectors for SCSI and PCMCIA. 40 MHz clock is used for SCSI control. Power source is DC 5V from PC.

### 1.2 Tested System Details

Model number	FCC ID	Description	Cable Description
JDWBL820 (*)	ACJMKKPSJDWBL820A	PCMCIA Card for CD-ROM Player	-----
KXL-820A	ACJ5Z6KXL-810A	CD-ROM Player	Metallic Hoods, Shielded cable (Ferrite core at the end of the cable)
KXL-D32	-----	Ni-Cd Battery	-----
PA1232C9 (Toshiba)	CJ6UK334	Notebook Computer	Plastic Hoods, Unshielded cable
461-P (Compaq)	BR8SM-5514CP	CRT Display	Metallic Hoods, Shielded circular cable
KX-P3200	ACJ5Z6KX-P3200	Serial Printer	Metallic Hoods, Shielded circular cable
KX-P3200	ACJ5Z6KX-P3200	Parallel Printer	Metallic Hoods, Shielded circular cable
M-S28 (Compaq)	DZL210472	Mouse, serial I/F	Metallic Hoods, Shielded circular cable
KX-WZ337	-----	AC Adaptor for CD-ROM Player	Plastic Hoods, Unshielded circular cable (Ferrite core at the end of the cable)
MDR-E515	-----	Ear Phone	Plastic Hoods, Unshielded cable

(\*) EUT

### 3 System Test Configuration

#### 3.1 Justification

The system was configured for testing in atypical fashion (as a customer would normally use it).

#### 3.2 Video Mode justification

The system was tested in the default 80× 25 text mode and in the highest resolution graphics mode of 640× 480. Since the default mode was found to be worst case, this mode was used to collect the included data.

#### 3.3 EUT Exercise Software

The EUT exercise program used during radiated and conducted testing was designed to exercise the various system components in a manner similar to a typical use. The software, contained on hard disc, is started after set up from keyboard. Once loaded, the program sequentially exercise each system component in turn. The sequence used is : (1) the CD-ROM Player seeks and reads data through EUT, (2) read data printed on the monitor, (3) printer prints a line of H, (4) hard disc and 3-1/2 inch disc exercised. The complete cycle takes about 3 seconds and is repeated continuously. As the mouse is strictly input devices, no data is transmitted to it during test. It is, however, continuously scanned for data input activity. A software, print a line of H in the monitor, was tested during preliminary emission test, but it did not increase emission significantly. Therefore, read data from the CD-ROM Player printed on the monitor during the final qualification test.

#### 3.4 Special Accessories

To connected this equipment to CD-ROM Player, it requires use of a shielded SCSI cable, with a ferrite core attached on end of cable, in order to comply with FCC requirements. This cable is supplied to the end user with the EUT.

3.5 Configuration of Tested System

Configuration of tested system is shown in figure 3.1.

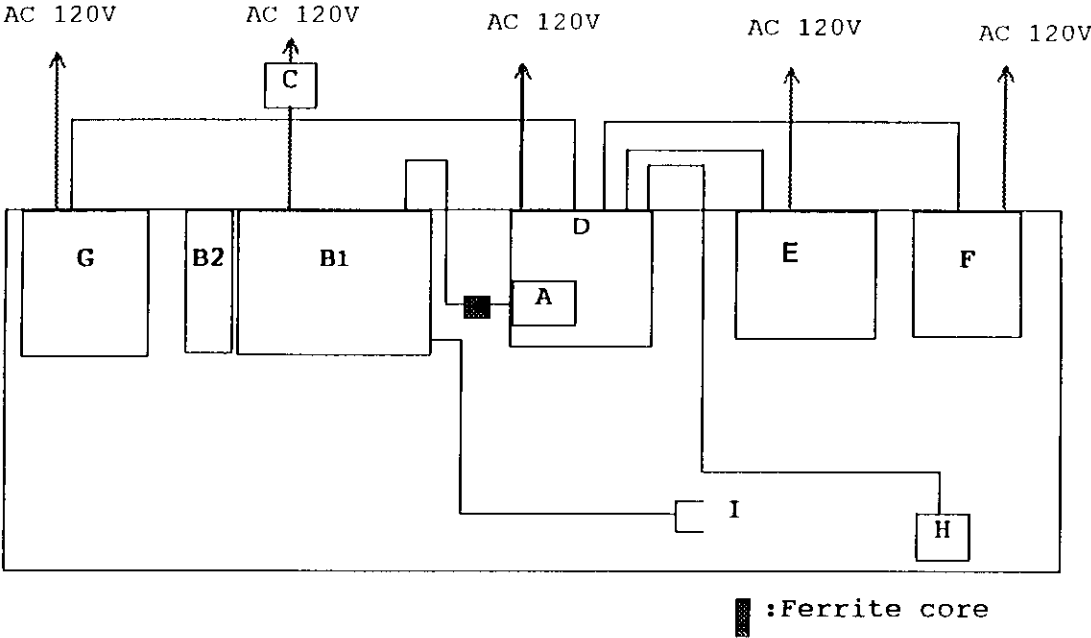

Fig. 3.1

4 Block Diagram of Equipment

Block diagram of PC card is shown in figure 4.1.

5 Conducted And Radiated Measurement Photos

See Attachment A

6 Conducted Emission Data

See Attachment A

7 Radiated Emission Data

See Attachment A

8 Photos of Tested EUT

The following photos are attached

Figure 8.1 Top view of the EUT

Figure 8.2 Bottom view of the EUT

Figure 8.3 PC Board, component side

Figure 8.4 PC Board, foil side

Attachment A Measurement Report of Class B Digital Device

FCC/REL:ON AUG 14 1998

Attachment A

Measurement Report of Class B Digital Device

EMI Test Report No.: TR98-0502S

**EMI TEST REPORT**

CLASS B  
INFORMATION TECHNOLOGY EQUIPMENT (ITE)

Model No. : JDWBL820

**KME**

KME EMC TESTING LABORATORY

Issue Date : July 29, 1998

Kyushu Matsushita Electric Co., Ltd. ( K M E )  
Corporate Quality Assurance Division ( C Q A D )

1471 , Murata-cho, Tosu-shi,  
Saga-ken 841-8501, Japan TEL 0942-83-3131

Do not reproduce except in full, without the written approval of  
KME EMC TESTING LABORATORY

Table of Contents

EMI TEST REPORT ON ITE-----	3
1. Applicant	5. Measurement Procedure
2. Description of Device	6. Place of Measurement
3. Date of Receipt and Measurement	7. Facility Number
4. Regulations Applied	8. Measurement Results
[1] TEST RESULT	
1. RADIATED EMISSION MEASUREMENTS -----	4
(RSS-210 Section 6.2.2 (g1)(4) and Section 6.2.2(g1)(6))	
2. AC POWERLINE CONDUCTED MEASUREMENTS -----	5
(RSS-210 Section 6.6/7.4, Worst Case)	
[2] DESCRIPTION OF THE TEST EQUIPMENT	
1. The equipment under test (EUT) -----	6, 7
2. Type of Interface Cables -----	8
3. AC power cord -----	8
[3] PHOTOGRAPHS OF THE TEST SET-UP	
1. RADIATED EMISSION MEASUREMENTS -----	9
2. AC POWERING CONDUCTED MEASUREMENTS -----	9
[4] TEST ARRANGEMENT AND LIST OF TEST INSTRUMENTS ----- 10	
[5] ATTACHMENT ----- 11	

Model No.: JDWBL820

Issue Date : July 29, 1998

Kyushu Matsushita Electric Co., Ltd.  
 KME EMC TESTING LABORATORY  
 1471, Murata-cho, Tosu-shi,  
 Saga-ken, 841-8501 JAPAN  
 TEL 0942-83-3131  
 FAX 0942-81-2794

### EMI TEST REPORT ON ITE

1. Applicant : Kyushu Matsushita Electric Co., Ltd.  
 1-62, 4-Chome, Minoshima  
 Hakata-Ku, Fukuoka, 812-8531 Japan  
**KIKUSUI PRECISION SYSTEM DIVISION.**  
 1080, TAKANO, KIKUSUI-MACHI  
 TAMANA-GUN, KUMAMOTO,  
 865-0193 JAPAN
2. Description of Device  
 a) Type of EUT : **CD-ROM Interface Card**  
 b) Category : CLASS B  
 INFORMATION TECHNOLOGY EQUIPMENT (ITE)  
 c) Trade Name : Panasonic  
 d) Model No. : **JDWBL820**  
 e) Serial No. : 8GAVA000001  
 f) Date of Manufacture : May 1998  
 g) Power Supply : 100-120VAC 60Hz  
 (CD-ROM Interface Card:DC 5V or 3.3V from PC )
3. Date of Receipt : June 1998  
 Date of Measurement : June 25, 1998
4. Regulations Applied : FCC Rules and Regulations Part 15
5. Measurement Procedure : ANSI C63.4-1992
6. Place of Measurement : Kyushu Matsushita Electric Co., Ltd.  
 KME EMC SAGA SITE
7. Facility Number : (FCC) 31040/SIT/KYUSHU
8. Measurement Results : The results obtained from the measuring of  
 the above-mentioned device are as shown in  
 the attached sheets.  
 This results in this report apply only  
 to the sample(s) tested.

July 29, 1998

Chikito Kuwano \_\_\_\_\_  
 Quality manager

*C. Kuwano*

**KME**

**[1] TEST RESULT**

\* TEST CONDITION OF EQUIPMENT UNDER TEST (EUT)

- 1 Configuration of EUT : Refer to the sheet No.9
- 2 Operating Condition : 32bit Card Bus Mode
- 3 EUT Grounding : None
- 4 Power Rating : 120VAC 60Hz

( CD-ROM Interface Card : DC 3.3V from PC )

**1 RADIATED EMISSION MEASUREMENTS [30M-1GHz][ FCC Part 15 ](CLASS B)**

[Test Site : Open Area Test Site]

\* TEST CONDITION OF INSTRUMENT

EUT Warm-up Time : 30 minutes

- 1) Resolution Bandwidth : 120kHz DATA : July 25, 1998
- 2) Detector Function : QP(30-1000MHz) Temp.: 25 °C Humi.: 84 %

**(1-1) 32bit Card Bus MODE**

EMISSION FREQUENCY ( MHz )	ANTENNA POLARITY ( H, V )	METER READING at 3 m ( dBμV )	ANTENNA FACTOR AND PREAMPGAIN ( dB )	EMISSION LEVEL at 3 m		FCC LIMIT ( μV/m )
				(dBμV/m)	( μV/m )	
30.471	V	52.4	-25.8	26.6	21.4	100
52.135	V	48.9	-19.7	29.2	28.9	100
70.035	V	44.8	-17.7	27.1	22.7	100
83.450	V	45.0	-17.1	27.9	24.9	100
99.444	V	45.6	-15.9	29.7	30.6	150
136.104	V	43.5	-12.2	31.3	36.8	150
148.122	H	45.2	-11.7	33.5	47.4	150
160.135	H	43.7	-10.9	32.8	43.7	150
187.985	V	35.9	-9.1	26.8	21.9	150
232.104	H	44.4	-7.3	37.1	71.7	200
265.230	H	40.0	-5.2	34.8	55.0	200
298.390	H	40.8	-6.2	34.6	53.8	200
331.572	H	40.9	-4.6	36.3	65.4	200
397.913	V	38.8	-1.7	37.1	71.7	200
497.344	H	35.7	0.6	36.3	65.4	200
530.514	V	35.1	1.2	36.3	65.4	200
596.826	H	30.0	3.6	33.6	47.9	200
796.279	H	25.7	7.5	33.2	45.8	200

Tested by : S. Mori

NOTES:1) The cable loss is included into the antenna factor and pre-amp gain.

2) Sample of calculation at 30.471 MHz

$$52.4 \text{ (dB}\mu\text{V)} - 25.8 \text{ (dB}\mu\text{V/m)} = 26.6 \text{ (dB}\mu\text{V/m)}$$

$$\frac{26.6}{20} = 1.330$$

$$10 = 10 = 21.4 \text{ (}\mu\text{V/m)}$$

Reviewed by : M. Horie *M. Horie*



2. AC POWERLINE CONDUCTED MEASUREMENTS [ FCC ] (CLASS B)

[ Test Site : Shielded Room ]

\* TEST CONDITION OF INSTRUMENT

EUT Warm-up Time : 30 minutes

1) Resolution Bandwidth : 9 kHz

DATE : July 25, 1998

2) Detector Function : QP

Temp.: 24 °C Humi.: 45 %

(2-1) 32bit Card Bus MODE

	EMISSION FREQUENCY ( MHz )	METER READING ( dB $\mu$ V )	LISN FACTOR ( dB )	EMISSION LEVEL		FCC LIMIT ( $\mu$ V)
				(dB $\mu$ V)	( $\mu$ V)	
Va	0.4500	10.0	-0.1	9.9	3.2	250
	0.5175	32.6	0.0	32.6	42.7	250
	1.9670	33.1	0.0	33.1	45.2	250
	4.5500	36.8	0.1	36.9	70.0	250
	17.8940	23.4	0.6	24.0	15.9	250
	27.7240	22.1	1.1	23.2	14.5	250
	30.0000	16.9	1.1	18.0	8.0	250
Vb	0.4500	7.8	-0.1	7.7	2.5	250
	0.5175	31.7	0.0	31.7	38.5	250
	1.9670	30.4	0.0	30.4	33.2	250
	4.5500	35.7	0.1	35.8	61.7	250
	17.8940	22.2	0.6	22.8	13.9	250
	27.7240	23.5	1.1	24.6	17.0	250
	30.0000	15.7	1.1	16.8	7.0	250

Tested by : S. Mori

NOTES:1) LISN factor includes the cable loss for 5 meter.

2) Sample of calculation at 0.4500 MHz  
 $10.0 \text{ (dB}\mu\text{V)} - 0.1 \text{ (dB}\mu\text{V)} = 9.9 \text{ (dB}\mu\text{V)}$   
 $9.9 / 20 = 0.495$   
 $10 = 10 = 3.2 \text{ (}\mu\text{V)}$

Reviewed by : M. Horie *M. Horie*



[2] The equipment under test (EUT)

2.1 Configuration of EUT  
( RADIATED EMISSION )

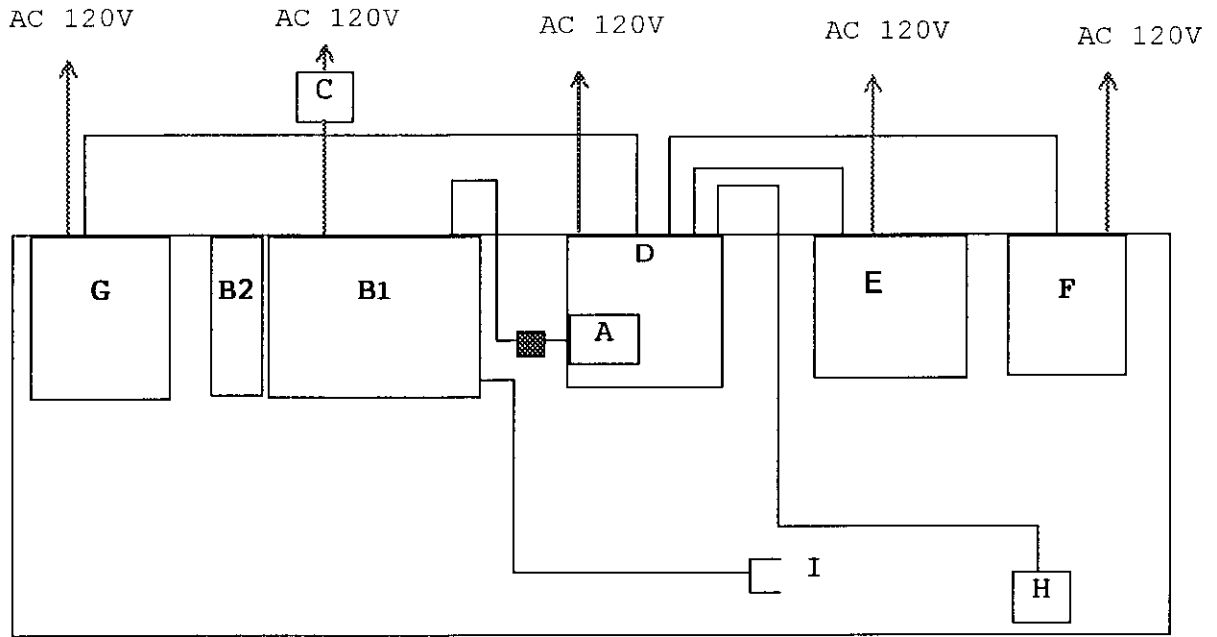

■ : Ferrite core

		Model No.		Serial No.	FCC ID
A	CD-ROM Interface Card[EUT]	JDWBL820	[ K M E ]	8GAVA000001	ACJKMKPSJDWBL820A
B1	CD-ROM Player [EUT]	KXL-810A	[ K M E ]	8CMEKC03021	ACJ5Z6KXL-810A
B2	NI-CD BATTERY Pack [EUT]	KXL-D32	[ K M E ]	8AMDQA02132	---
C	AC Adapter for CD-ROM PLAYER [EUT]	KX-W2337	[ K M E ]	---	---
D	Personal Computer	PA1232C9	[Toshiba]	12620228	CJ6UK334
E	Monitor	461-P	[COMPAQ]	34045350K422	BR8SM-5514CP
F	Serial Printer	KX-P3200	[ K M E ]	7AMDMB12002	ACJ5Z6KX-P3200
G	Parallel Printer	KX-P3200	[ K M E ]	7AMDMB11936	ACJ5Z6KX-P3200
H	Mouse	M-S28	[COMPAQ]	141649-001	DZL210472
I	Ear Phone	MDR-E515	[SONY]	---	---

## 2.2 Configuration of EUT ( AC POWERLINE CONDUCTED )

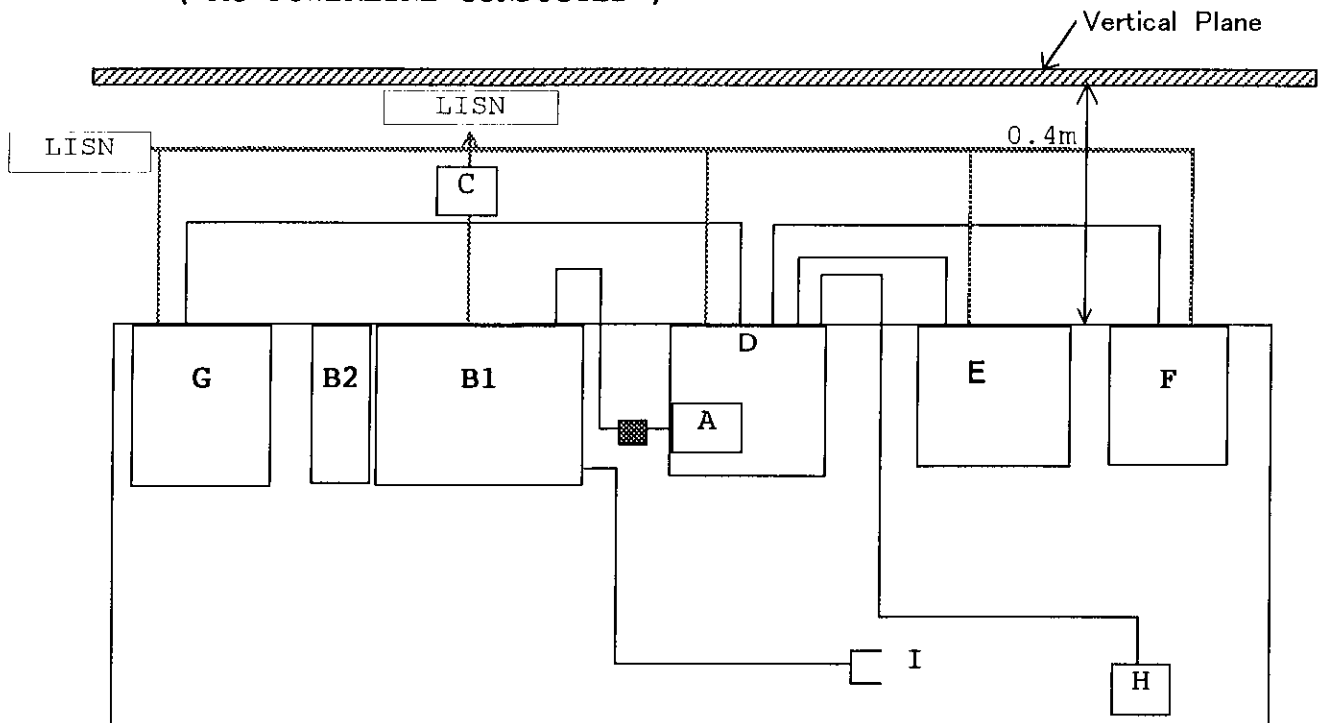

EUT Table : 2.1(W) × 1.0(D) × 0.8(H) (M)

 : Ferrite core

		Model No.		Serial No.	FCC ID
A	CD-ROM Interface Card[EUT]	JDWBL820	[ K M E ]	8GAVA000001	ACJKMKPSJDWBL820A
B1	CD-ROM Player [EUT]	KXL-810A	[ K M E ]	8CMEKC03021	ACJ526KXL-810A
B2	NI-CD BATTERY Pack [EUT]	KXL-D32	[ K M E ]	8AMDQA02132	---
C	AC Adapter for CD-ROM PLAYER [EUT]	KX-WZ337	[ K M E ]	---	---
D	Personal Computer	PA1232C9	[Toshiba]	12620228	CJ6UK334
E	Monitor	461-P	[COMPAQ]	34045350K422	BR8SM-5514CP
F	Serial Printer	KX-P3200	[ K M E ]	7AMDMB12002	ACJ526KX-P3200
G	Parallel Printer	KX-P3200	[ K M E ]	7AMDMB11936	ACJ526KX-P3200
H	Mouse	M-S28	[COMPAQ]	141649-001	DZL210472
I	Ear Phone	MDR-E515	[SONY]	---	---

**2.3 Type of Interface Cables**

[ Main Frame ]	[ Peripheral ]		[Length]	Number
*20X PCMCIA CD-ROM Player	(B1) --- CD-ROM Interface Card (A) Metallic Hoods, Shielded Cable (Ferrite core at the end of the cable)		0.5 m	1
*20X PCMCIA CD-ROM Player	(B1) --- Earphone (I) Plastic Hoods, Unshielded Cable		1.2 m	1
*Serial Printe Printer	(F) --- Personal Computer (D) Metallic Hoods, Shielded Circular Cable		2.1 m	1
*Parallel Printer	(G) --- Personal Computer (D) Metallic Hoods, Shielded Circular Cable		2.1 m	1
*Monitor	(E) --- Personal Computer (D) Metallic Hoods, Shielded Circular Cable		1.0 m	1
*Mouse	(H) --- Personal Computer (D) Metallic Hoods, Shielded Circular Cable		1.0 m	1

**2.4 AC Power Cord**

[ Main Frame ]	[ Peripheral ]		[Length]	Number
*20X PCMCIA CD-ROM Player (AC Adapter)	(B1) --- Plastic Hoods, Unshielded Circular Cable (Ferrite core at the end of the cable)		2.0 m	1
*Personal Computer	(D) --- Plastic Hoods, Unshielded Circular Cable		2.0 m	1

**2.5 Arrangement of the Interface Cables**

Refer to the photographs.

These interface cables were positioned so as to produce the highest maximum at every frequency between 30MHz and 1000 MHz, being within the manner assumed to be a typical operating condition.

**[4] TEST ARRANGEMENT AND LIST OF INSTRUMENTS****4.1 TEST EQUIPMENTS OF RADIATED EMISSION MEASUREMENTS**

[ Measuring Apparatus ]	[ Model ]	[ Calibrated Untill ]
<b>* Field Strength Meter</b> Frequency Range : 9 KHz - 30 MHz Detector Function : CISPR Quasi Peak and Average IF Bandwidth : 200 Hz( 9 -150 KHz ), 9 KHz( 0.15 -30 MHz)	<b>Rohde &amp; Schwarz</b>  <b>ESH3</b>	<b>Feb. 1999</b>
<b>* Field Strength Meter</b> Frequency Range : 20 - 1300 MHz Detector Function : CISPR Quasi Peak IF Bandwidth : 120 KHz ( 20 - 1300 MHz )	<b>Rohde &amp; Schwarz</b>  <b>ESVS-10</b>	<b>Nov. 1998</b>
<b>* Pre-amplifier</b> Frequency Range : 0.1 - 1300 MHz Gain : 27±1dB	<b>Hewlett Packard</b>  <b>8447D</b>	<b>Feb. 1999</b>
<b>* Spectrum Analyzer</b> Frequency Range : 0.01 - 3600 MHz	<b>ADVANTEST</b>  <b>TR4135</b>	<b>Feb. 1999</b>
<b>* Line Impedance Stabilization Network (LISN) (50 μH/50 Ω)</b>	<b>Kyoritsu Electrical Works, Ltd.</b>	<b>Feb. 1999</b>
<b>* Dipole Antenna</b>  Tuning Range : 30 - 500 MHz Tuning Range : 500 - 1000 MHz	<b>Kyoritsu Electrical Works, Ltd.</b>  <b>KBA-511A</b> <b>KBA-611</b>	<b>Jan. 1999</b> <b>Jan. 1999</b>

---

**[5] ATTACHMENT**

**5.1 RADIATED EMISSION MEASUREMENTS**

[Attachment Sheet No.]

\* QP Data ----- Sheet 1 of 2 Sheets  
32bit Card Bus mode(Horizontal/Vertical, 30-300MHz)

**5.2 AC POWERLINE CONDUCTED MEASUREMENTS**

\* QP Data ----- Sheet 2 of 2 Sheets  
32bit Card Bus(Va/Vb, 0.45-30MHz)

**RADIATED EMISSION**

Model Name : CD-ROM PLAYER  
 Parts No. : JDWBL820  
 Serial No. : 8GAVA000001  
 Detector : QP  
 Points : 18  
 Limit1: [FCC Part 15] Class B<3m>

Temp. : 25□□  
 Humi.% : 84%  
 Comment : 32bit Card Bus  
 Date : 1998.7.25  
 EMI Receiver(s) :

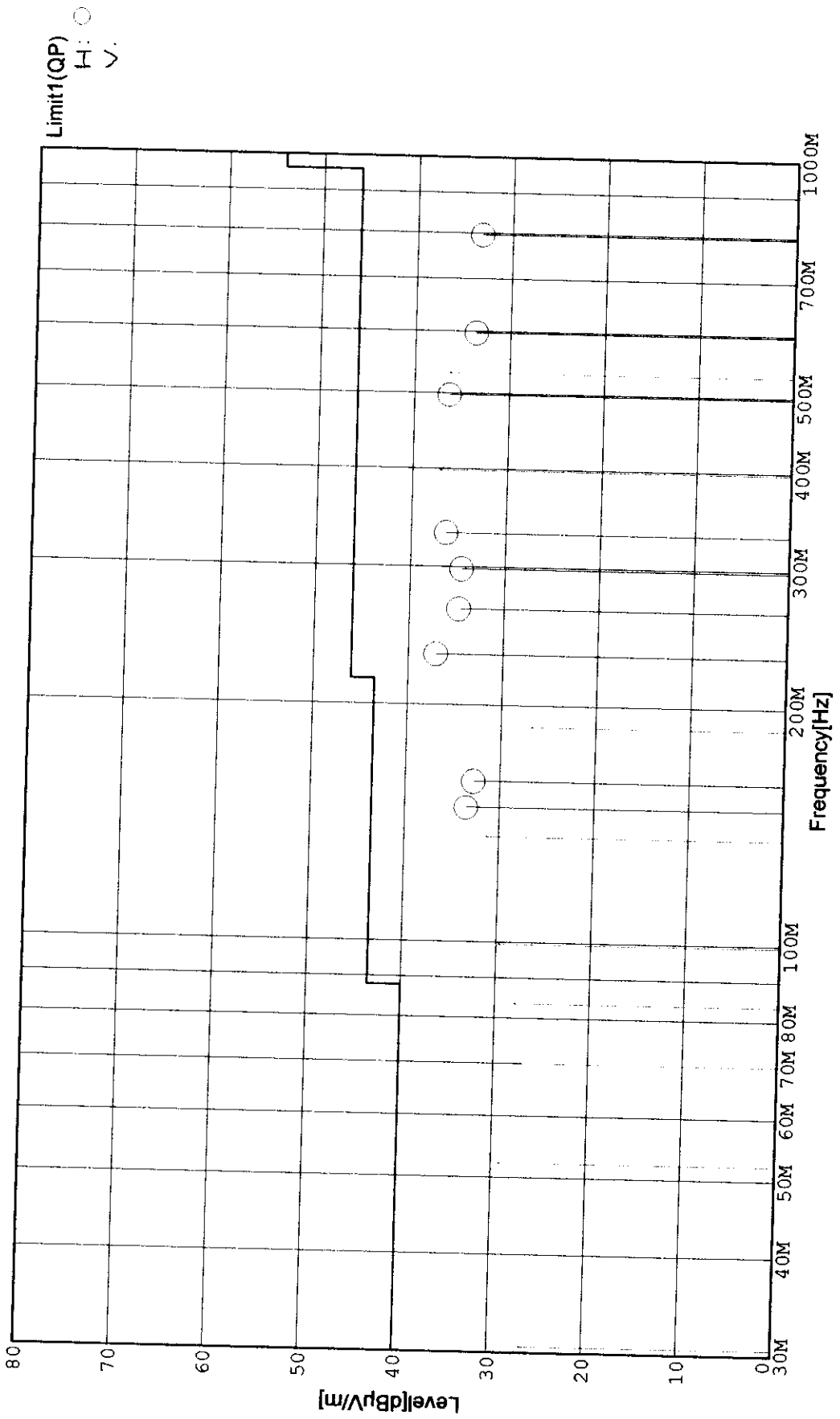

LINE CONDUCTION

Model Name : CD-ROM PLAYER  
Parts No. : JDWBL820  
Serial No. : 8GAVA000001  
Detector : QP  
Points : 14  
Limit1: [FCC Part15] Class B

Temp. : 24□□  
Humi.% : 45%  
Comment : 32bit Card Bus  
Date : 1998.7.25  
EMI Receiver(s):

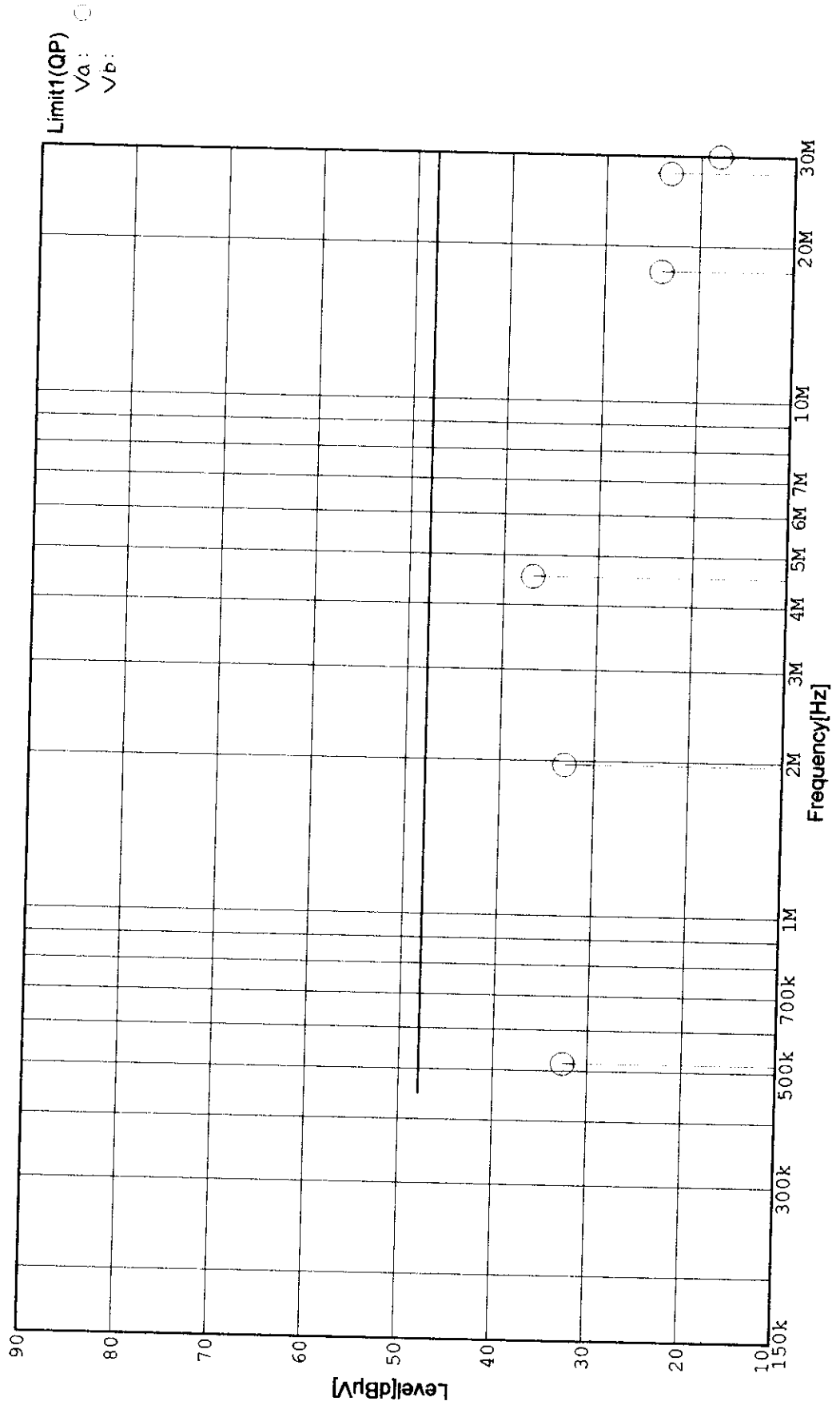

Limit1(QP)  
Va: ○  
Vb: ○