

# EMI TEST REPORT

**Test Report No. : 31CE0189-HO-03-A**

**Applicant** : **Panasonic Corporation of North America**  
**Type of Equipment** : **Printer**  
**Model No.** : **JT-H340PR-E1**  
**FCC ID** : **ACJJT-H340PR1**  
**Test standard** : **FCC Part 15 Subpart B: 2010 Class B**  
**Test Result** : **Complied**

1. This test report shall not be reproduced in full or partial, without the written approval of UL Japan, Inc.
2. The results in this report apply only to the sample tested.
3. This sample tested is in compliance with the above regulation.
4. The test results in this report are traceable to the national or international standards.
5. This test report must not be used by the customer product certification, approval, or endorsement by NVLAP, NIST, or any agency of the Federal Government.

**Date of test:**

November 29 to December 7, 2010

**Representative test  
engineer:**



Hisayoshi Sato  
Engineer of EMC Service

**Approved by:**



Takahiro Hatakeda  
Leader of EMC Service



NVLAP LAB CODE: 200572-0

This laboratory is accredited by the NVLAP LAB CODE 200572-0, U.S.A. The tests reported herein have been performed in accordance with its terms of accreditation. \*As for the range of Accreditation in NVLAP, you may refer to the WEB address, <http://www.ul.com/japan/jpn/pages/services/emc/about/mark1/index.jsp#nvlap>

<b>CONTENTS</b>	<b>PAGE</b>
<b>SECTION 1: Customer information .....</b>	<b>3</b>
<b>SECTION 2: Equipment under test (E.U.T.) .....</b>	<b>3</b>
<b>SECTION 3: Test specification, procedures &amp; results .....</b>	<b>4</b>
<b>SECTION 4: Operation of E.U.T. during testing .....</b>	<b>7</b>
<b>SECTION 5: Conducted Emission .....</b>	<b>11</b>
<b>SECTION 6: Radiated Emission .....</b>	<b>12</b>
<b>APPENDIX 1: Photographs of test setup.....</b>	<b>13</b>
Conducted Emission .....	13
Radiated Emission .....	14
Worst Case Position (Horizontal: X-axis/ Vertical:Y-axis) .....	18
<b>APPENDIX 2: Data of EMI test .....</b>	<b>19</b>
Conducted Emission .....	19
Radiated Emission .....	20
<b>APPENDIX 3: Test instruments .....</b>	<b>24</b>

## **SECTION 1: Customer information**

Company Name : Panasonic System Networks Co., Ltd.  
Address : 4-3-1 Tsunashima-higashi, Kohoku-ku, Yokohama-shi, Kanagawa,  
223-8639 Japan  
Telephone Number : +81-45-540-5500  
Facsimile Number : +81-45-540-1272  
Contact Person : Hitoshi Yoshida  
\* Panasonic System Networks Co., Ltd. is on behalf of the applicant : Panasonic Corporation of North America.

## **SECTION 2: Equipment under test (E.U.T.)**

### **2.1 Identification of E.U.T.**

Type of Equipment : Printer  
Model No. : JT-H340PR-E1  
Serial No. : Refer to Section 4, Clause 4.2  
Rating : DC7.2V (Battery), DC9.5V (AC Adaptor)  
Receipt Date of Sample : November 26, 2010  
Country of Mass-production : Japan  
Condition of EUT : Engineering prototype  
(Not for Sale: This sample is equivalent to mass-produced items.)  
Modification of EUT : No Modification by the test lab

### **2.2 Product Description**

Model No: JT-H340PR-E1, (referred to as the EUT in this report), is the Printer.  
Printer that can print thermal recording paper by four inches in width of paper and can be carried.  
Printed data are sent by Bluetooth, USB, and IrDA I/F from PC or Handheld PC etc.  
It has Charge circuit of built-in battery.

### **General Specification**

Clock frequency(ies) in the system : CPU:66.4MHz, USB Controller : 48MHz,  
Bluetooth Controller : 16MHz,  
Bluetooth Communication Clock : 26MHz  
Power Supply : Battery: DC 7.2V 1300 / 1600mAh  
AC Adaptor: DC9.5V (AC120V/60Hz)

### **Radio Specification**

Radio Type : Transceiver (Bluetooth Ver.2.1 + EDR Compliance (Class 2))  
Frequency of Operation : 2402-2480MHz  
Bandwidth & Channel spacing : 1MHz & 1MHz/CH  
Modulation : FHSS  
Power Supply (radio part input) : DC 3.1 to 3.3V  
Antenna type : Chip Antenna  
Antenna Gain : +2.1 dBi

### **Series model**

JT-H340PR-XX (X: maybe any alphanumeric character, dash or blank)

Model Differences

Suffix "X" in model name JT-H340PR-XX is replaced with any alphanumeric character, dash or blank to denote the difference in case color, logo design, appearance of operation panel, label design, and USB input connector.

JT-H340PR-E1 has series model as Model No. JT-H340PR-E8.

The difference: JT-H340PR-E1 (Paper roll width is 114mm) and JT-H340PR-E8 (Paper roll width is 80mm).

---

**UL Japan, Inc.**

**Head Office EMC Lab.**

4383-326 Asama-cho, Ise-shi, Mie-ken 516-0021 JAPAN

Telephone : +81 596 24 8116

Facsimile : +81 596 24 8124

### **SECTION 3: Test specification, procedures & results**

#### **3.1 Test specification**

Test Specification : FCC Part 15 Subpart B: 2010, final revised on October 13, 2010  
Title : FCC 47CFR Part15 Radio Frequency Device  
Subpart B Unintentional Radiators

#### **3.2 Procedures and results**

<b>Item</b>	<b>Test Procedure</b>	<b>Limits</b>	<b>Deviation</b>	<b>Worst margin</b>	<b>Result</b>
Conducted emission	FCC: ANSI C63.4: 2003 7. AC powerline conducted emission measurements	Class B	N/A	[QP] 8.4dB 0.18911MHz, N	Complied
	IC: ICES-003 4.1			[AV] 18.9dB 0.18911MHz, N	
Radiated emission	FCC: ANSI C63.4: 2003 8. Radiated emission measurements	Class B	N/A *1)	6.1dB 491.366MHz, QP Vertical	Complied
	IC: ICES-003 4.1				

\*Note: UL Japan, Inc's EMI Work Procedure QPM05.

\*1) Measurements were limited up to 1GHz since the highest frequency of internal source of the EUT is less than 108MHz.

#### **3.3 Addition to standard**

No addition, exclusion nor deviation has been made from the standard.

**UL Japan, Inc.**

**Head Office EMC Lab.**

4383-326 Asama-cho, Ise-shi, Mie-ken 516-0021 JAPAN

Telephone : +81 596 24 8116

Facsimile : +81 596 24 8124

### 3.4 Uncertainty

#### EMI

The following uncertainties have been calculated to provide a confidence level of 95% using a coverage factor k=2.

Test room (semi-anechoic chamber)	Conducted emission (+dB)
	150kHz-30MHz
No.1	3.1dB
No.2	3.3dB
No.3	3.7dB
No.4	3.2dB

Test room (semi-anechoic chamber)	Radiated emission						
	(3m*)(+dB)				(1m*)(+dB)		(0.5m*)(+dB)
	9kHz -30MHz	30MHz -300MHz	300MHz -1GHz	1GHz -10GHz	10GHz -18GHz	18GHz -26.5GHz	26.5GHz -40GHz
No.1	3.5dB	5.1dB	5.2dB	4.8dB	5.1dB	4.4dB	4.3dB
No.2	4.0dB	5.1dB	5.2dB	4.8dB	5.0dB	4.3dB	4.2dB
No.3	4.2dB	4.7dB	5.2dB	4.8dB	5.0dB	4.5dB	4.2dB
No.4	4.0dB	5.0dB	5.1dB	4.8dB	5.0dB	5.1dB	4.2dB

\*3m/1m/0.5m = Measurement distance

#### Conducted Emission test

The data listed in this test report has enough margin, more than the site margin.

#### Radiated emission test(3m)

The data listed in this test report has enough margin, more than the site margin.

**UL Japan, Inc.**

**Head Office EMC Lab.**

4383-326 Asama-cho, Ise-shi, Mie-ken 516-0021 JAPAN

Telephone : +81 596 24 8116

Facsimile : +81 596 24 8124

### 3.5 Test Location

UL Japan, Inc. Head Office EMC Lab. \*NVLAP Lab. code: 200572-0  
4383-326 Asama-cho, Ise-shi, Mie-ken 516-0021 JAPAN  
Telephone : +81 596 24 8116 Facsimile : +81 596 24 8124

	FCC Registration Number	IC Registration Number	Width x Depth x Height (m)	Size of reference ground plane (m) / horizontal conducting plane	Other rooms
No.1 semi-anechoic chamber	313583	2973C-1	19.2 x 11.2 x 7.7m	7.0 x 6.0m	No.1 Power source room
No.2 semi-anechoic chamber	655103	2973C-2	7.5 x 5.8 x 5.2m	4.0 x 4.0m	-
No.3 semi-anechoic chamber	148738	2973C-3	12.0 x 8.5 x 5.9m	6.8 x 5.75m	No.3 Preparation room
No.3 shielded room	-	-	4.0 x 6.0 x 2.7m	N/A	-
No.4 semi-anechoic chamber	134570	2973C-4	12.0 x 8.5 x 5.9m	6.8 x 5.75m	No.4 Preparation room
No.4 shielded room	-	-	4.0 x 6.0 x 2.7m	N/A	-
No.5 semi-anechoic chamber	-	-	6.0 x 6.0 x 3.9m	6.0 x 6.0m	-
No.6 shielded room	-	-	4.0 x 4.5 x 2.7m	4.75 x 5.4 m	-
No.6 measurement room	-	-	4.75 x 5.4 x 3.0m	4.75 x 4.15 m	-
No.7 shielded room	-	-	4.7 x 7.5 x 2.7m	4.7 x 7.5m	-
No.8 measurement room	-	-	3.1 x 5.0 x 2.7m	N/A	-
No.9 measurement room	-	-	8.0 x 4.5 x 2.8m	2.0 x 2.0m	-
No.10 measurement room	-	-	2.6 x 2.8 x 2.5m	2.4 x 2.4m	-
No.11 measurement room	-	-	3.1 x 3.4 x 3.0m	2.4 x 3.4m	-

\* Size of vertical conducting plane (for Conducted Emission test) : 2.0 x 2.0m for No.1, No.2, No.3, and No.4 semi-anechoic chambers and No.3 and No.4 shielded rooms.

### 3.6 Test set up, Data of EMI, and Test instruments

Refer to APPENDIX.

## SECTION 4: Operation of E.U.T. during testing

### 4.1 Operating modes



The mode(s) : 1) Bluetooth I/F continuous Printing mode (for Radiated Emission test only)  
2) USB I/F continuous Printing mode (for Radiated Emission test only)  
3) IrDA I/F continuous Printing mode (for Radiated Emission test only)  
4) Battery Charge mode  
[During the above modes]  
Control Personal Computer: Printing data communication by Bluetooth, USB, and IrDA, I/F  
Printer: 1. Printing after receiving printing data by each I/F.  
2. Charging to Inner battery  
(no other operating such as printing during the charging)  
AC Adaptor for Battery-Charging: Power supply for battery-charging  
from Printer to commercial AC power supply

Justification : The system was configured in typical fashion (as a customer would normally use it) for testing.

### 4.2 Configuration and peripherals

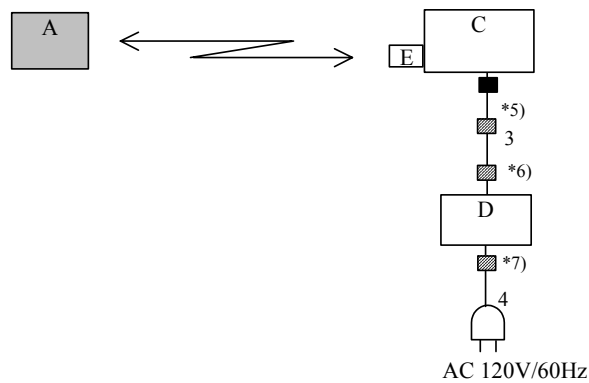
#### 1) Bluetooth I/F continuous Printing mode



 : Non-standard Ferrite Core  
 : Standard Ferrite Core

\* Cabling and setup were taken into consideration and test data was taken under worse case conditions.

**2) USB I/F continuous Printing mode**

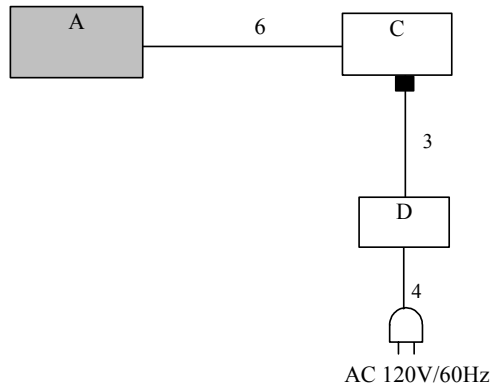



 : Standard Ferrite Core

\* Cabling and setup were taken into consideration and test data was taken under worse case conditions.

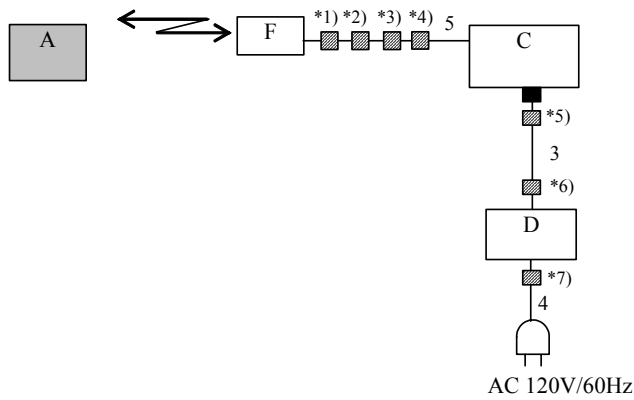
**3) IrDA I/F continuous Printing mode**



 : Non-standard Ferrite Core

 : Standard Ferrite Core

\* Cabling and setup were taken into consideration and test data was taken under worse case conditions.

#### 4) Battery Charge Mode

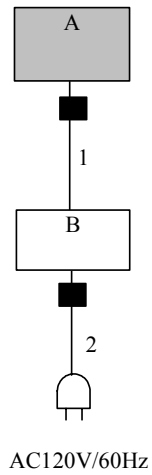

■ : Standard Ferrite Core

\* Cabling and setup were taken into consideration and test data was taken under worse case conditions.

**Description of EUT and Support equipment**

No.	Item	Model number	Serial number	Manufacturer	Remark
A	Printer	JT-H340PR-E1	00007	Panasonic System Networks Co., Ltd.	EUT
B	AC Adaptor	JT-H300AD	061610741023	Panasonic System Networks Co., Ltd.	-
C	PC	MP-XP7310LL	08901491	Victor	-
D	AC Adaptor	ADP-50SB	KAW0408000437	Victor	-
E	Bluetooth Adaptor	BT-MicroEDR2X	12IH24216AR	PCi	-
F	IR Computer Link	ACT-IR224UN-LN19-LE	000067	ACTiSYS	-

**List of cables used**

No.	Name	Length (m)	Shield		Remark
			Cable	Connector	
1	DC Cable	1.3	Unshielded	Unshielded	-
2	AC Cable	1.7	Unshielded	Unshielded	-
3	DC Cable	1.3	Shielded	Shielded	-
4	AC Cable	1.6	Unshielded	Unshielded	-
5	USB Cable	0.4	Shielded	Shielded	-
6	USB Cable	1.5	Shielded	Shielded	-

<Notes for Ferrite cores>

- \*1) Model No. SFT59SN, (Manufacturer: TKK), 2 turns
- \*2) Model No. SFT72SN, (Manufacturer: TKK), 3 turns
- \*3) Model No. SFT72SN, (Manufacturer: TKK), 3 turns
- \*4) Model No. SFT152613N, (Manufacturer: TKK), 4 turns
- \*5) Model No. SFT36SN, (Manufacturer: TKK), 2 turns
- \*6) Model No. SFT59SN, (Manufacturer: TKK), 2 turns
- \*7) Model No. TFT152613N, (Manufacturer: TKK), 3 turns

**UL Japan, Inc.**

**Head Office EMC Lab.**

4383-326 Asama-cho, Ise-shi, Mie-ken 516-0021 JAPAN

Telephone : +81 596 24 8116

Facsimile : +81 596 24 8124

## **SECTION 5: Conducted Emission**

### **5.1 Operating environment**

Test place : No.1 semi anechoic chamber.  
Temperature : See data  
Humidity : See data

### **5.2 Test configuration**

EUT was placed on a urethane platform of nominal size, 1.0m by 1.5m, raised 0.8m above the conducting ground plane. The rear of tabletop was located 40cm to the vertical conducting plane. The rear of EUT and its peripherals was aligned and flushed with rear of tabletop. All other surfaces of tabletop were at least 80cm from any other grounded conducting surface. EUT was located 80cm from the LISN/AMN and excess AC cable was bundled in center. I/O cables that were connected to the other peripherals were bundled in center. They were folded back and forth forming a bundle 30cm to 40cm long and were hanged at a 40cm height to the ground plane. Each EUT current-carrying power lead, except the ground (safety) lead, was individually connected through a LISN/AMN to the input power source. All unused 50 ohm connectors of the LISN/AMN were resistivity terminated in 50 ohm when not connected to the measuring equipment. Photographs of the set up are shown in Appendix 1.

Frequency range : 0.15 MHz-30MHz  
EUT position : Table top  
EUT operation mode : See Clause 4.1

### **5.3 Test procedure**

The AC Mains Terminal Continuous disturbance Voltage has been measured with the EUT within a semi anechoic chamber. The EUT was connected to a Line Impedance Stabilization Network (LISN)/ Artificial Mains network (AMN). An overview sweep with peak detection has been performed. The measurements have been performed with a quasi-peak detector and if required, with an average detector.

The conducted emission measurements were made with the following detector function of the test receiver.

Detector Type : Quasi-Peak and Average  
IF Bandwidth : 9 kHz

### **5.4 Test result**

Summary of the test results: Pass

Date: November 30, 2010

Test engineer: Hisayoshi Sato

---

**UL Japan, Inc.**

**Head Office EMC Lab.**

4383-326 Asama-cho, Ise-shi, Mie-ken 516-0021 JAPAN

Telephone : +81 596 24 8116

Facsimile : +81 596 24 8124

## **SECTION 6: Radiated Emission**

### **6.1 Operating environment**

Test place : No.1 semi anechoic chamber  
Temperature : See data  
Humidity : See data

### **6.2 Test configuration**

EUT was placed on a urethane platform of nominal size, 1.0m by 1.5m, raised 0.8m above the conducting ground plane. The EUT was set on the edge of the tabletop.  
Test was made with the antenna positioned in both the horizontal and vertical planes of polarization. The measurement antenna was varied in height above the conducting ground plane to obtain the maximum signal strength. Photographs of the set up are shown in Appendix 1.

### **6.3 Test conditions**

Frequency range : 30MHz-300MHz (Biconical antenna) / 300MHz-1000MHz (Logperiodic antenna)  
Test distance : 3m  
EUT position : Table top  
EUT operation mode : See Clause 4.1

### **6.4 Test procedure**

The height of the measuring antenna varied between 1 and 4m and EUT was rotated a full revolution in order to obtain the maximum value of the electric field intensity.  
The measurements were performed for both vertical and horizontal antenna polarization with the Test Receiver, or the Spectrum Analyzer.  
The radiated emission measurements were made with the following detector function of the test receiver and the Spectrum analyzer.

Frequency	Below 1GHz
Instrument used	Test Receiver
IF Bandwidth	QP: BW 120kHz

- The carrier level and noise levels were confirmed at each position of X, Y and Z axes of EUT and the test was made at the position that has the maximum noise.

### **6.5 Test result**

Summary of the test results: Pass

Date: November 29 and 30, 2010  
December 7, 2010

Test engineer: Hisayoshi Sato  
Makoto Kosaka