



EMI TEST REPORT

Test Report No. : 30KE0073-HO-A-R2

Applicant : Panasonic Corporation of North America
Type of Equipment : Printer
Model No. : JT-H300PR-E1
FCC ID : ACJJT-H300PR1
Test standard : FCC Part 15 Subpart B 2010 Class B
Test Result : Complied

1. This test report shall not be reproduced in full or partial, without the written approval of UL Japan, Inc.
2. The results in this report apply only to the sample tested.
3. This sample tested is in compliance with the above regulation.
4. The test results in this report are traceable to the national or international standards.
5. This test report must not be used by the customer product certification, approval, or endorsement by NVLAP, NIST, or any agency of the Federal Government.
6. This report is a revised version of 30KE0073-HO-A-R1. 30KE0073-HO-A-R1 is replaced with this report.

Date of test:

June 11 and July 5, 2010

Representative test engineer:

K. Kawamura

Keisuke Kawamura
Engineer of EMC Service

Approved by:

T. Hatakeeda

Takahiro Hatakeeda
Leader of EMC Service



NVLAP LAB CODE: 200572-0

This laboratory is accredited by the NVLAP LAB CODE 200572-0, U.S.A. The tests reported herein have been performed in accordance with its terms of accreditation. *As for the range of Accreditation in NVLAP, you may refer to the WEB address, <http://www.ul.com/japan/jpn/pages/services/emc/about/mark1/index.jsp#nvlap>

UL Japan, Inc.

Head Office EMC Lab.

4383-326 Asama-cho, Ise-shi, Mie-ken 516-0021 JAPAN

Telephone : +81 596 24 8116

Facsimile : +81 596 24 8124

MF060b (10.05.10)

| CONTENTS | PAGE |
|--|-------------|
| SECTION 1: Customer information | 3 |
| SECTION 2: Equipment under test (E.U.T.) | 3 |
| SECTION 3: Test specification, procedures & results | 4 |
| SECTION 4: Operation of E.U.T. during testing | 7 |
| SECTION 5: Conducted Emission | 11 |
| SECTION 6: Radiated Emission | 12 |
| APPENDIX 1: Photographs of test setup..... | 13 |
| Conducted Emission | 13 |
| Radiated Emission | 14 |
| Worst Case Position (Horizontal: X-axis/ Vertical:X-axis) | 18 |
| APPENDIX 2: Data of EMI test | 19 |
| Conducted Emission | 19 |
| Radiated Emission | 20 |
| APPENDIX 3: Test instruments | 24 |

SECTION 1: Customer information

Company Name : Panasonic System Networks Co., Ltd.
Address : 4-3-1 Tsunashima-higashi, Kohoku-ku, Yokohama-shi, Kanagawa,
223-8639 Japan
Telephone Number : +81-45-544-3467
Facsimile Number : +81-45-544-3486
Contact Person : Tatsuki Kawanishi
* Panasonic System Networks Co., Ltd. is on behalf of the applicant : Panasonic Corporation of North America.

SECTION 2: Equipment under test (E.U.T.)

2.1 Identification of E.U.T.

Type of Equipment : Printer
Model No. : JT-H300PR-E1
Serial No. : Refer to Section 4, Clause 4.2
Receipt Date of Sample : June 10, 2010
Country of Mass-production : Japan
Condition of EUT : Engineering prototype
(Not for Sale: This sample is equivalent to mass-produced items.)
Modification of EUT : No Modification by the test lab

2.2 Product Description

Model No: JT-H300PR-E1, (referred to as the EUT in this report), is the Printer.
Printer that can print thermal recording paper by two inches in width of paper and can be carried.
Printed data are sent by Bluetooth, USB, and IrDA I/F from PC or Handheld PC etc.
It has Charge circuit of built-in battery.

General Specification

Clock frequency(ies) in the system : CPU:66.4MHz, USB Controller : 48MHz,
Bluetooth Controller : 16MHz,
Bluetooth Communication Clock : 26MHz (Bluetooth)
Power Supply : Battery: DC7.2V 1150mAh
AC Adaptor: DC9.5V (AC120V/60Hz)
Radio Type : Transceiver (Bluetooth Ver.2.1 + EDR Compliance (Class 2))
Frequency of Operation : 2402-2480MHz
Bandwidth & Channel spacing : 1MHz & 1MHz/CH
Modulation : FHSS
Power Supply (radio part input) : DC 3.1 to 3.3V
Antenna type : Chip Antenna
Antenna Gain : 2.1 dBi (max)

Series model

JT-H300PRXXX (X: maybe any alphanumeric character, dash or blank)

Model Differences

Suffix "X" in model name JT-H300PRXXX is replaced with any alphanumeric character, dash or blank to denote the difference in case color, logo design, appearance of operation panel, label design, and USB input connector.

JT-H300PR-E1 has series model as Model No. JT-H300PR-U1.

The difference : JT-H300PR-E1 (Battery is removable) and "JT-H300PR-U1 (Battery is installed)

UL Japan, Inc.

Head Office EMC Lab.

4383-326 Asama-cho, Ise-shi, Mie-ken 516-0021 JAPAN

Telephone : +81 596 24 8116

Facsimile : +81 596 24 8124

SECTION 3: Test specification, procedures & results

3.1 Test specification

Test Specification : FCC Part 15 Subpart B 2010, final revised on January 22, 2010 and effective March 1, 2010

Title : FCC 47CFR Part15 Radio Frequency Device
Subpart B Unintentional Radiators

3.2 Procedures and results

| Item | Test Procedure | Limits | Deviation | Worst margin | Result |
|--------------------------|--|---------|-----------|--|----------|
| Conducted emission | FCC: ANSI C63.4: 2003 7. AC powerline conducted emission measurements | Class B | N/A | [QP] 17.2dB 0.19892MHz, L [AV] 23.7dB 0.19892MHz, L | Complied |
| Radiated emission *1) | FCC: ANSI C63.4: 2003 8. Radiated emission measurements | Class B | N/A | 6.9dB 324.899MHz Horizontal | Complied |

*Note: UL Japan, Inc's EMI Work Procedure QPM05.

*1) Measurements were limited up to 1GHz since the highest frequency of internal source of the EUT is less than 108MHz.

3.3 Addition to standard

No addition, exclusion nor deviation has been made from the standard.

UL Japan, Inc.

Head Office EMC Lab.

4383-326 Asama-cho, Ise-shi, Mie-ken 516-0021 JAPAN

Telephone : +81 596 24 8116

Facsimile : +81 596 24 8124

3.4 Uncertainty

EMI

The following uncertainties have been calculated to provide a confidence level of 95% using a coverage factor k=2.

| Test room (semi-anechoic chamber) | Conducted emission (+dB) |
|--------------------------------------|-----------------------------|
| | 150kHz-30MHz |
| No.1 | 2.6dB |
| No.2 | 2.9dB |
| No.3 | 3.3dB |
| No.4 | 2.8dB |

| Test room (semi-anechoic chamber) | Radiated emission (10m*)(±dB) | | |
|--------------------------------------|----------------------------------|------------------|-----------------|
| | 9kHz -30MHz | 30MHz -300MHz | 300MHz -1GHz |
| No.1 | 2.7dB | 4.8dB | 5.0dB |
| No.2 | - | - | - |
| No.3 | - | - | - |
| No.4 | - | - | - |

*10m = Measurement distance

| Test room (semi-anechoic chamber) | Radiated emission | | | | | | |
|--------------------------------------|-------------------|------------------|-----------------|----------------|-----------------|-------------------|-------------------|
| | (3m*)(±dB) | | | | (1m*)(±dB) | | (0.5m*)(±dB) |
| | 9kHz -30MHz | 30MHz -300MHz | 300MHz -1GHz | 1GHz -10GHz | 10GHz -18GHz | 18GHz -26.5GHz | 26.5GHz -40GHz |
| No.1 | 2.9dB | 4.8dB | 5.0dB | 3.9dB | 4.3dB | 4.5dB | 4.3dB |
| No.2 | 3.5dB | 4.8dB | 5.1dB | 4.0dB | 4.2dB | 4.4dB | 4.2dB |
| No.3 | 3.8dB | 4.6dB | 4.7dB | 4.0dB | 4.2dB | 4.5dB | 4.2dB |
| No.4 | 3.5dB | 4.4dB | 4.9dB | 4.0dB | 4.2dB | 4.6dB | 4.2dB |

*3m/1m/0.5m = Measurement distance

Conducted Emission test

The data listed in this test report has enough margin, more than the site margin.

Radiated emission test(3m)

The data listed in this test report has enough margin, more than the site margin.

UL Japan, Inc.

Head Office EMC Lab.

4383-326 Asama-cho, Ise-shi, Mie-ken 516-0021 JAPAN

Telephone : +81 596 24 8116

Facsimile : +81 596 24 8124

3.5 Test Location

UL Japan, Inc. Head Office EMC Lab. *NVLAP Lab. code: 200572-0
4383-326 Asama-cho, Ise-shi, Mie-ken 516-0021 JAPAN
Telephone : +81 596 24 8116 Facsimile : +81 596 24 8124

| | FCC Registration Number | IC Registration Number | Width x Depth x Height (m) | Size of reference ground plane (m) / horizontal conducting plane | Other rooms |
|----------------------------|-------------------------|------------------------|----------------------------|--|------------------------|
| No.1 semi-anechoic chamber | 313583 | 2973C-1 | 19.2 x 11.2 x 7.7m | 7.0 x 6.0m | No.1 Power source room |
| No.2 semi-anechoic chamber | 655103 | 2973C-2 | 7.5 x 5.8 x 5.2m | 4.0 x 4.0m | - |
| No.3 semi-anechoic chamber | 148738 | 2973C-3 | 12.0 x 8.5 x 5.9m | 6.8 x 5.75m | No.3 Preparation room |
| No.3 shielded room | - | - | 4.0 x 6.0 x 2.7m | N/A | - |
| No.4 semi-anechoic chamber | 134570 | 2973C-4 | 12.0 x 8.5 x 5.9m | 6.8 x 5.75m | No.4 Preparation room |
| No.4 shielded room | - | - | 4.0 x 6.0 x 2.7m | N/A | - |
| No.5 semi-anechoic chamber | - | - | 6.0 x 6.0 x 3.9m | 6.0 x 6.0m | - |
| No.6 shielded room | - | - | 4.0 x 4.5 x 2.7m | 4.75 x 5.4 m | - |
| No.6 measurement room | - | - | 4.75 x 5.4 x 3.0m | 4.75 x 4.15 m | - |
| No.7 shielded room | - | - | 4.7 x 7.5 x 2.7m | 4.7 x 7.5m | - |
| No.8 measurement room | - | - | 3.1 x 5.0 x 2.7m | N/A | - |
| No.9 measurement room | - | - | 8.0 x 4.5 x 2.8m | 2.0 x 2.0m | - |
| No.10 measurement room | - | - | 2.6 x 2.8 x 2.5m | 2.4 x 2.4m | - |
| No.11 measurement room | - | - | 3.1 x 3.4 x 3.0m | 2.4 x 3.4m | - |

* Size of vertical conducting plane (for Conducted Emission test) : 2.0 x 2.0m for No.1, No.2, No.3, and No.4 semi-anechoic chambers and No.3 and No.4 shielded rooms.

3.6 Test set up, Data of EMI, and Test instruments

Refer to APPENDIX.

SECTION 4: Operation of E.U.T. during testing

4.1 Operating mode(s)

The mode(s) : 1) Bluetooth I/F continuous Printing mode (for Radiated Emission test only)
2) IrDA I/F continuous Printing mode (for Radiated Emission test only)
3) USB I/F continuous Printing mode (for Radiated Emission test only)
4) Battery Charge mode
[During the above modes]
Control Personal Computer: Printing data communication by Bluetooth, USB, IrDA, and I/F
Printer: 1. Printing after receiving printing data by each I/F.
2. Charging to Inner battery
(no other operating such as printing during the charging)
AC Adaptor for Battery-Charging: Power supply for battery-charging
from Printer to commercial AC power supply

Justification : The system was configured in typical fashion (as a customer would normally use it) for testing.

4.2 Configuration and peripherals

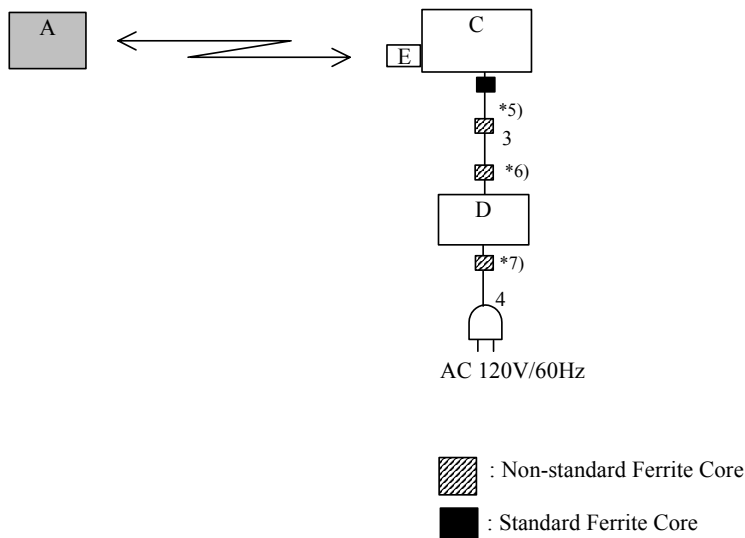

1) Bluetooth I/F continuous Printing mode

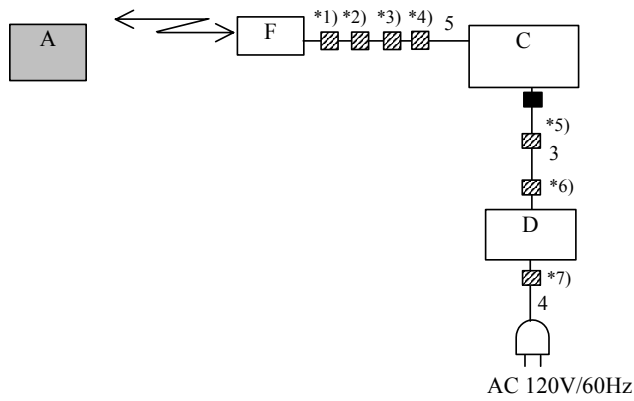

* Cabling and setup were taken into consideration and test data was taken under worse case conditions.

2) IrDA I/F continuous Printing mode



 : Non-standard Ferrite Core
 : Standard Ferrite Core

* Cabling and setup were taken into consideration and test data was taken under worse case conditions.

3) USB I/F continuous Printing mode

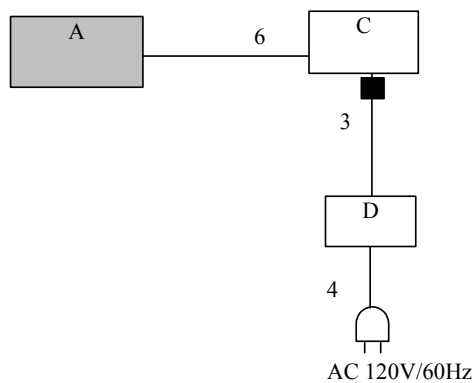

 : Standard Ferrite Core

* Cabling and setup were taken into consideration and test data was taken under worse case conditions.

4) Battery Charge Mode

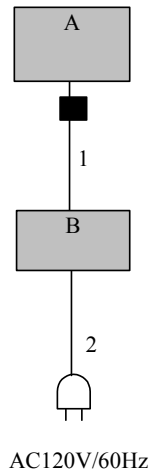

 : Standard Ferrite Core

* Cabling and setup were taken into consideration and test data was taken under worse case conditions.

Description of EUT and Support equipment

| No. | Item | Model number | Serial number | Manufacturer | Remark |
|-----|-------------------|---------------------|---------------|-------------------------------------|---------|
| A | Printer | JT-H300PR-E1 | 2 | Panasonic System Networks Co., Ltd. | EUT |
| B | AC Adaptor | JT-H300AD-P1 | S01195041021 | Panasonic System Networks Co., Ltd. | EUT *1) |
| C | PC | MP-XP7310LL | 08901491 | Victor | - |
| D | AC Adaptor | ADP-50SB | KAW0408000437 | Victor | - |
| E | Bluetooth Adaptor | BT-MicroEDR2X | 12IH16245AR | PCi | - |
| F | IR Computer Link | ACT-IR224UN-LN19-LE | 000067 | ACTiSYS | - |

*1) This AC Adaptor is included with EUT as verification and exempt from certification.

List of cables used

| No. | Name | Length (m) | Shield | | Remark |
|-----|-----------|------------|------------|------------|--------|
| | | | Cable | Connector | |
| 1 | DC Cable | 1.3 | Unshielded | Unshielded | - |
| 2 | AC Cable | 1.9 | Unshielded | Unshielded | - |
| 3 | DC Cable | 1.3 | Shielded | Shielded | - |
| 4 | AC Cable | 1.6 | Unshielded | Unshielded | - |
| 5 | USB Cable | 0.4 | Shielded | Shielded | - |
| 6 | USB Cable | 1.5 | Shielded | Shielded | - |

<Notes for Ferrite cores>

- *1) Model No. SFT59SN, (Manufacturer: TKK), 2 turns
- *2) Model No. SFT72SN, (Manufacturer: TKK), 3 turns
- *3) Model No. SFT72SN, (Manufacturer: TKK), 3 turns
- *4) Model No. SFT152613N, (Manufacturer: TKK), 4 turns
- *5) Model No. SFT36SN, (Manufacturer: TKK), 2 turns
- *6) Model No. SFT59SN, (Manufacturer: TKK), 2 turns
- *7) Model No. TFT152613N, (Manufacturer: TKK), 3 turns

UL Japan, Inc.

Head Office EMC Lab.

4383-326 Asama-cho, Ise-shi, Mie-ken 516-0021 JAPAN

Telephone : +81 596 24 8116

Facsimile : +81 596 24 8124

SECTION 5: Conducted Emission

5.1 Operating environment

Test place : No.2 semi anechoic chamber
Temperature : See data
Humidity : See data

5.2 Test configuration

EUT was placed on a urethane platform of nominal size, 0.5m by 1.0m, raised 0.8m above the conducting ground plane. The rear of tabletop was located 40cm to the vertical conducting plane. The rear of EUT and its peripherals was aligned and flushed with rear of tabletop. All other surfaces of tabletop were at least 80cm from any other grounded conducting surface. EUT was located 80cm from the LISN/AMN and excess AC cable was bundled in center. I/O cables that were connected to the other peripherals were bundled in center. They were folded back and forth forming a bundle 30cm to 40cm long and were hanged at a 40cm height to the ground plane. Each EUT current-carrying power lead, except the ground (safety) lead, was individually connected through a LISN/AMN to the input power source. All unused 50 ohm connectors of the LISN/AMN were resistivity terminated in 50 ohm when not connected to the measuring equipment. Photographs of the set up are shown in Appendix 1.

Frequency range : 0.15 MHz-30MHz
EUT position : Table top
EUT operation mode : See Clause 4.1

5.3 Test procedure

The AC Mains Terminal Continuous disturbance Voltage has been measured with the EUT within a semi anechoic chamber. The EUT was connected to a Line Impedance Stabilization Network (LISN)/ Artificial Mains network (AMN). An overview sweep with peak detection has been performed. The measurements have been performed with a quasi-peak detector and if required, with an average detector.

The conducted emission measurements were made with the following detector function of the test receiver.

Detector Type : Quasi-Peak and Average
IF Bandwidth : 9 kHz

5.4 Test result

Summary of the test results: Pass

The test results and limit are rounded off to one decimal place, so some differences might be observed.

Date: July 5, 2010

Test engineer: Keisuke Kawamura

UL Japan, Inc.

Head Office EMC Lab.

4383-326 Asama-cho, Ise-shi, Mie-ken 516-0021 JAPAN

Telephone : +81 596 24 8116

Facsimile : +81 596 24 8124

SECTION 6: Radiated Emission

6.1 Operating environment

Test place : No.4 and No.2 semi anechoic chamber(s)
Temperature : See data
Humidity : See data

6.2 Test configuration

EUT was placed on urethane platforms of nominal size, 1.0m by 1.5m and 0.5m by 1.0m, raised 0.8m above the conducting ground plane.

The EUT was set on the edge of the tabletop.

Test was made with the antenna positioned in both the horizontal and vertical planes of polarization. The measurement antenna was varied in height above the conducting ground plane to obtain the maximum signal strength.

Photographs of the set up are shown in Appendix 1.

6.3 Test conditions

Frequency range : 30MHz-300MHz (Biconical antenna) / 300MHz-1000MHz (Logperiodic antenna)
Test distance : 3m
EUT position : Table top
EUT operation mode : See Clause 4.1

6.4 Test procedure

The height of the measuring antenna varied between 1 and 4m and EUT was rotated a full revolution in order to obtain the maximum value of the electric field intensity.

The measurements were performed for both vertical and horizontal antenna polarization with the Test Receiver, or the Spectrum Analyzer.

The radiated emission measurements were made with the following detector function of the test receiver and the Spectrum analyzer.

| | |
|-----------------|---------------|
| Frequency | Below 1GHz |
| Instrument used | Test Receiver |
| IF Bandwidth | QP: BW 120kHz |

- The noise levels were confirmed at each position of X, Y and Z axes of EUT to see the position of maximum noise, and the test was made at the position that has the maximum noise.

6.5 Test result

Summary of the test results: Pass

The test results and limit are rounded off to one decimal place, so some differences might be observed.

Date: June 11 and July 5, 2010

Test engineer: Katsunori Okai and Keisuke Kawamura

UL Japan, Inc.

Head Office EMC Lab.

4383-326 Asama-cho, Ise-shi, Mie-ken 516-0021 JAPAN

Telephone : +81 596 24 8116

Facsimile : +81 596 24 8124