



FCC RADIO TEST REPORT

FCC ID : ACJFZN1E
Equipment : Tablet Computer
Brand Name : Panasonic
Model Name : FZ-N1KB
Marketing Name : FZ-N1
Applicant : Panasonic Corporation of North America
Two Riverfront Plaza, 9th Floor, Newark, NJ
07102-5490
Manufacturer : Panasonic Mobile Communications Co., Ltd.
600 Saedo-cho, Tsuzuki-ku, Yokohama City
224-8539, Japan
Standard : FCC Part 15 Subpart E §15.407

The product was received on Apr. 22, 2020 and testing was started from Apr. 24, 2020 and completed on Jun. 02, 2020. We, SPORTON INTERNATIONAL INC., EMC & Wireless Communications Laboratory, would like to declare that the tested sample has been evaluated in accordance with the test procedures and has been in compliance with the applicable technical standards.

The report must not be used by the client to claim product certification, approval, or endorsement by TAF or any agency of government.

The test results in this report apply exclusively to the tested model / sample. Without written approval of SPORTON INTERNATIONAL INC. EMC & Wireless Communications Laboratory, the test report shall not be reproduced except in full.

Louis Wu

Approved by: Louis Wu

SPORTON INTERNATIONAL INC. EMC & Wireless Communications Laboratory

No. 52, Huaya 1st Rd., Guishan Dist., Taoyuan City, Taiwan (R.O.C.)



Table of Contents

History of this test report.....	3
Summary of Test Result.....	4
1 General Description	5
1.1 Product Feature of Equipment Under Test.....	5
1.2 Modification of EUT	5
1.3 Testing Location	6
1.4 Applicable Standards.....	6
2 Test Configuration of Equipment Under Test	7
2.1 Carrier Frequency and Channel	7
2.2 Test Mode.....	8
2.3 Connection Diagram of Test System.....	9
2.4 Support Unit used in test configuration and system	10
2.5 EUT Operation Test Setup	10
2.6 Measurement Results Explanation Example.....	10
3 Test Result	11
3.1 6dB and 26dB and 99% Occupied Bandwidth Measurement	11
3.2 Maximum Conducted Output Power Measurement	14
3.3 Power Spectral Density Measurement	15
3.4 Unwanted Emissions Measurement.....	17
3.5 AC Conducted Emission Measurement.....	22
3.6 Automatically Discontinue Transmission	24
3.7 Antenna Requirements	25
4 List of Measuring Equipment.....	26
5 Uncertainty of Evaluation	28
Appendix A. Conducted Test Results	
Appendix B. AC Conducted Emission Test Result	
Appendix C. Radiated Spurious Emission	
Appendix D. Radiated Spurious Emission Plots	
Appendix E. Duty Cycle Plots	
Appendix F. Setup Photographs	



Summary of Test Result

Report Clause	Ref Std. Clause	Test Items	Result (PASS/FAIL)	Remark
3.1	15.403 (i)	6dB & 26dB Bandwidth	Pass	-
3.1	2.1049	99% Occupied Bandwidth	Reporting only	-
3.2	15.407 (a)	Maximum Conducted Output Power	Pass	-
3.3	15.407 (a)	Power Spectral Density	Pass	-
3.4	15.407(b)	Unwanted Emissions	Pass	Under limit 10.59 dB at 37.760 MHz
3.5	15.207	AC Conducted Emission	Pass	Under limit 17.85 dB at 0.501 MHz
3.6	15.407 (c)	Automatically Discontinue Transmission	Pass	-
3.7	15.203 & 15.407 (a)	Antenna Requirement	Pass	-

Declaration of Conformity:

The test results with all measurement uncertainty excluded are presented in accordance with the regulation limits or requirements declared by manufacturers.

Comments and Explanations:

The declared of product specification for EUT presented in the report are provided by the manufacturer, and the manufacturer takes all the responsibilities for the accuracy of product specification.

Reviewed by: Wii Chang

Report Producer: Celery Wei

1 General Description

1.1 Product Feature of Equipment Under Test

WCDMA/LTE, Bluetooth, Wi-Fi 2.4GHz 802.11b/g/n/ac, Wi-Fi 5GHz 802.11a/n/ac, NFC, and GNSS.

Product Specification subjective to this standard	
Antenna Type	WWAN: Fixed Internal Antenna WLAN: Monopole Antenna Bluetooth: Monopole Antenna GPS / Glonass: Monopole Antenna NFC: Loop Antenna

Accessories Information		
Cradle	Brand Name	Panasonic
	Model Name	FZ-VEBN111A
AC Adapter 1	Brand Name	Panasonic
	Model Name	CF-AA6413A
AC Adapter 2	Brand Name	Panasonic
	Model Name	FZ-AAE184EM
USB Cable 1	Brand Name	Panasonic
	Model Name	K2KYYYY00221
USB Cable 2	Brand Name	N/A
	Model Name	SPA-US15
Battery	Brand Name	Panasonic
	Model Name	FZ-VZSUN110U

1.2 Modification of EUT

No modifications are made to the EUT during all test items.



1.3 Testing Location

Test Site	SPORTON INTERNATIONAL INC. EMC & Wireless Communications Laboratory	
Test Site Location	No.52, Huaya 1st Rd., Guishan Dist., Taoyuan City, Taiwan (R.O.C.) TEL: +886-3-327-3456 FAX: +886-3-328-4978	
Test Site No.	Sporton Site No.	
	TH05-HY	CO05-HY

Note: The test site complies with ANSI C63.4 2014 requirement.

Test Site	SPORTON INTERNATIONAL INC. EMC & Wireless Communications Laboratory	
Test Site Location	No.58, Aly. 75, Ln. 564, Wenhua 3rd, Rd., Guishan Dist., Taoyuan City, Taiwan (R.O.C.) TEL: +886-3-327-0868 FAX: +886-3-327-0855	
Test Site No.	Sporton Site No.	
	03CH15-HY	

Note: The test site complies with ANSI C63.4 2014 requirement.

FCC designation No.: TW1190 and TW0007

1.4 Applicable Standards

According to the specifications of the manufacturer, the EUT must comply with the requirements of the following standards:

- ♦ FCC Part 15 Subpart E
- ♦ FCC KDB 789033 D02 General UNII Test Procedures New Rules v02r01.
- ♦ FCC KDB 414788 D01 Radiated Test Site v01r01.
- ♦ ANSI C63.10-2013

Remark:

1. All test items were verified and recorded according to the standards and without any deviation during the test.
2. This EUT has also been tested and complied with the requirements of FCC Part 15, Subpart B, recorded in a separate test report.
3. The TAF code is not including all the FCC KDB listed without accreditation.



2 Test Configuration of Equipment Under Test

- a. The EUT has been associated with peripherals and configuration operated in a manner tended to maximize its emission characteristics in a typical application. Frequency range investigated: conduction emission (150 kHz to 30 MHz), radiation emission (9 kHz to the 10th harmonic of the highest fundamental frequency or to 40 GHz, whichever is lower). For radiated measurement, pre-scanned in three orthogonal panels, X, Y, Z. The worst cases (Y plane) were recorded in this report.

- b. AC power line Conducted Emission was tested under maximum output power.

2.1 Carrier Frequency and Channel

Frequency Band	Channel	Freq. (MHz)	Channel	Freq. (MHz)
5725-5850 MHz Band 4 (U-NII-3)	149	5745	157	5785
	151*	5755	159*	5795
	153	5765	161	5805
	155#	5775	165	5825

Note:

- 1. The above Frequency and Channel in "*" were 802.11n HT40 and 802.11ac VHT40.
- 2. The above Frequency and Channel in "#n" were 802.11ac VHT80.

2.2 Test Mode

Final test modes are considering the modulation and worse data rates as below table.

Modulation	Data Rate
802.11a	6 Mbps
802.11n HT20	MCS0
802.11n HT40	MCS0
802.11ac VHT20 (Covered by HT20)	MCS0
802.11ac VHT40 (Covered by HT40)	MCS0
802.11ac VHT80	MCS0

Test Cases	
AC Conducted Emission	Mode 1 : WCDMA Band V Idle + Bluetooth Link + WLAN (5GHz) Link + Camera (Front) + Earphone + Battery + USB Cable 1 (Charging from Adapter 2)
Remark: For Radiated Test Cases, the tests were performed with Adapter 2 and USB Cable 1.	

Ch. #		Band IV : 5725-5850 MHz			
		802.11a	802.11n HT20	802.11n HT40	802.11ac VHT80
L	Low	149	149	151	-
M	Middle	157	157	-	155
H	High	165	165	159	-

Remark: For radiation spurious emission, the final modulation and the worst data rate was reference the max RF conducted power.

2.3 Connection Diagram of Test System

<AC Conducted Emission Mode>

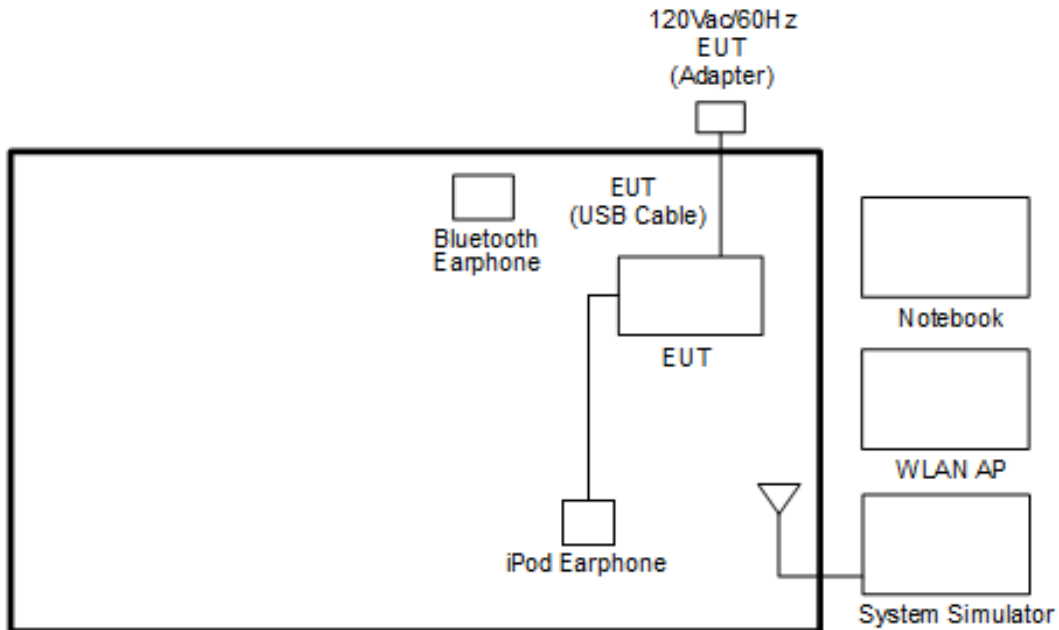

<WLAN Tx Mode>

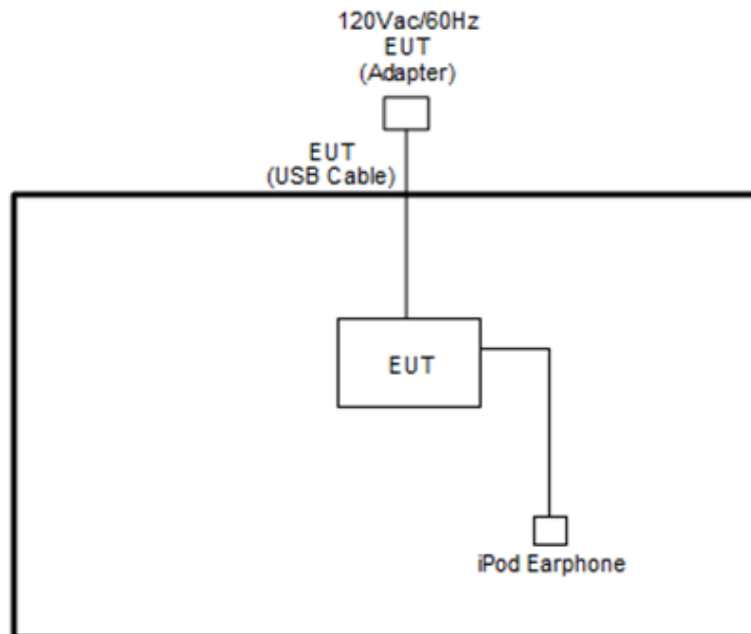



2.4 Support Unit used in test configuration and system

Item	Equipment	Trade Name	Model Name	FCC ID	Data Cable	Power Cord
1.	System Simulator	Anritsu	MT8820C	N/A	N/A	Unshielded, 1.8 m
2.	System Simulator	R&S	CMW 500	N/A	N/A	Unshielded, 1.8 m
3.	Notebook	DELL	Latitude E3340	FCC DoC	N/A	AC I/P: Unshielded, 1.2 m DC O/P: Shielded, 1.8 m
4.	Bluetooth Earphone	Sony Ericsson	MW600	PY7DDA-2029	N/A	N/A
5.	WLAN AP	ASUS	RT-AC66U	MSQ-RTAC66U	N/A	Unshielded, 1.8 m
6.	SD Card	SanDisk	MicroSD HC	FCC DoC	N/A	N/A
7.	iPod Earphone	Apple	N/A	Verification	Unshielded, 1.0m	N/A

2.5 EUT Operation Test Setup

The RF test items, utility "QRCT v3.0.303.0" was installed in Notebook which was programmed in order to make the EUT get into the engineering modes to provide channel selection, power level, data rate and the application type and for continuous transmitting signals.

2.6 Measurement Results Explanation Example

For all conducted test items:

The offset level is set in the spectrum analyzer to compensate the RF cable loss and attenuator factor between EUT conducted output port and spectrum analyzer. With the offset compensation, the spectrum analyzer reading level is exactly the EUT RF output level.

Example :

The spectrum analyzer offset is derived from RF cable loss and attenuator factor.

Offset = RF cable loss + attenuator factor.

Following shows an offset computation example with cable loss 4.2 dB and 10dB attenuator.

Offset(dB) = RF cable loss(dB) + attenuator factor(dB).

$$= 4.2 + 10 = 14.2 \text{ (dB)}$$

3 Test Result

3.1 6dB and 26dB and 99% Occupied Bandwidth Measurement

3.1.1 Description of 6dB and 26dB and 99% Occupied Bandwidth

The minimum 6 dB bandwidth shall be at least 500 kHz.

26dB and 99% Occupied bandwidth are reporting only.

3.1.2 Measuring Instruments

See list of measuring equipment of this test report.

3.1.3 Test Procedures

1. The testing follows FCC KDB 789033 D02 General UNII Test Procedures New Rules v02r01. Section C) Emission bandwidth for the band 5.725-5.85GHz
2. Set RBW = 100kHz.
3. Set the VBW $\geq 3 \times$ RBW.
4. Detector = Peak.
5. Trace mode = max hold
6. Measure the maximum width of the emission that is 6 dB down from the peak of the emission.
7. Measure and record the results in the test report.

3.1.4 Test Setup

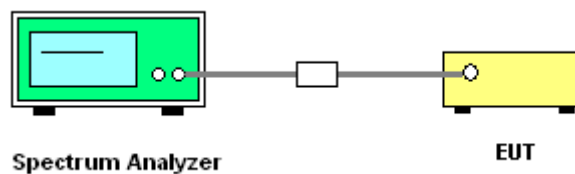

3.1.5 Test Result of 6dB and 26dB and 99% Occupied Bandwidth

Please refer to Appendix A.

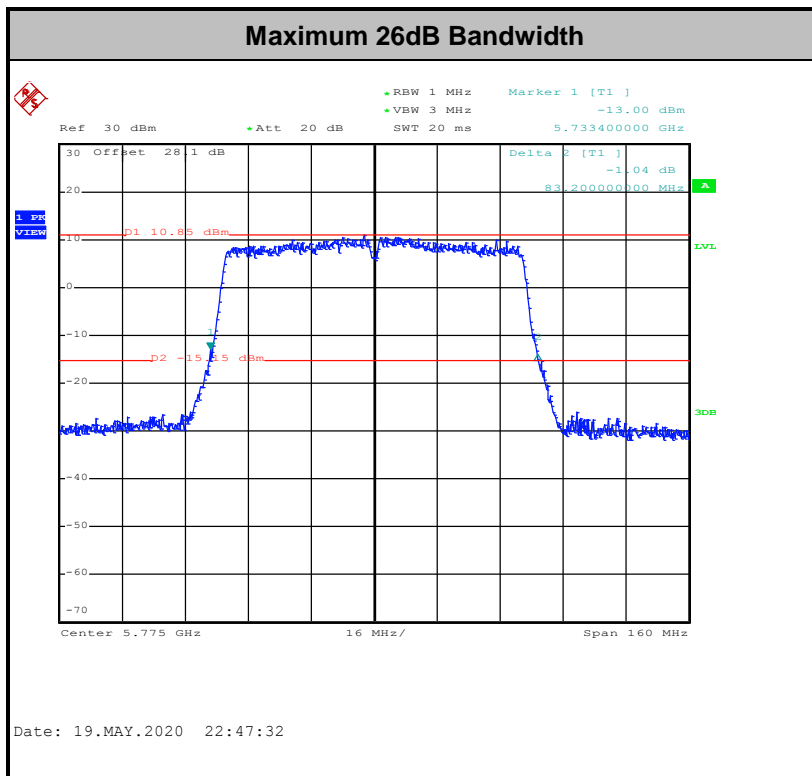
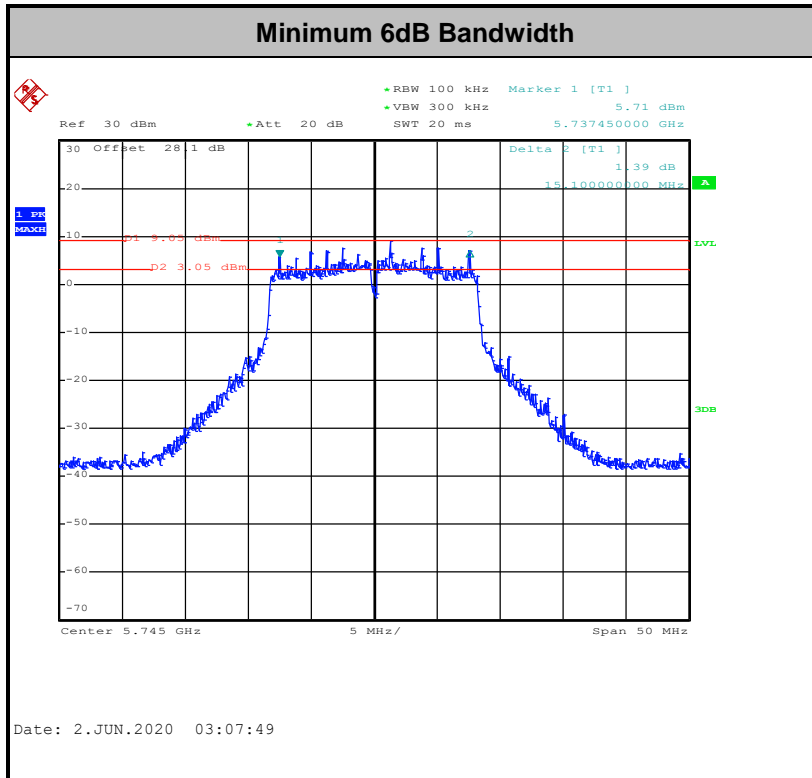

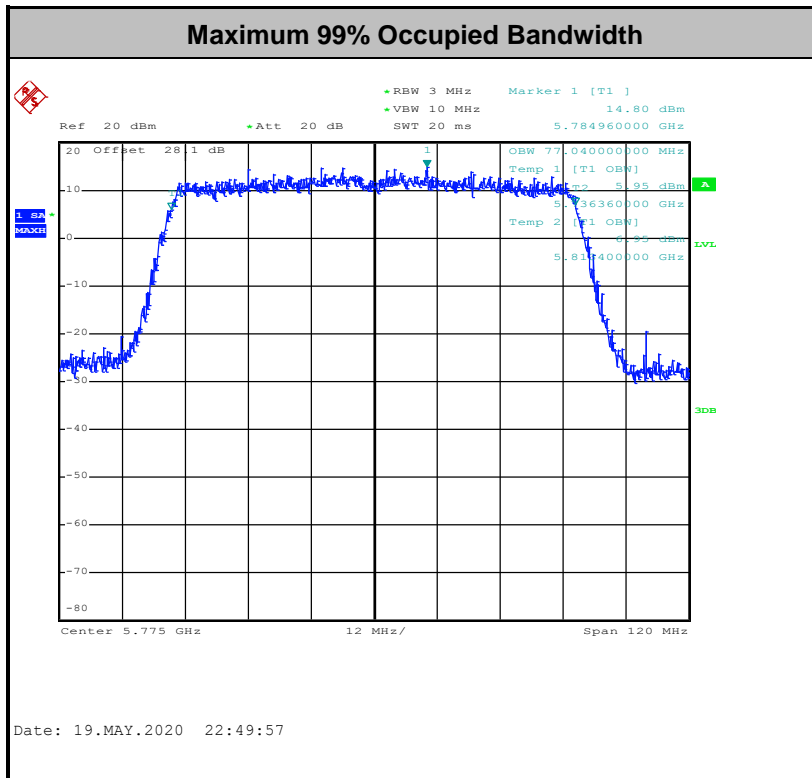

Note: The occupied channel bandwidth is maintained within the band of operation for all of the modulations.

3.2 Maximum Conducted Output Power Measurement

3.2.1 Limit of Maximum Conducted Output Power

For the band 5.725–5.85 GHz, the maximum conducted output power over the frequency band of operation shall not exceed 1 W.

If transmitting antennas of directional gain greater than 6 dBi are used, the peak output power shall be reduced by the amount in dB that the directional gain of the antenna exceeds 6 dBi.

3.2.2 Measuring Instruments

See list of measuring equipment of this test report.

3.2.3 Test Procedures

The testing follows Method PM-G of FCC KDB 789033 D02 General UNII Test Procedures New Rules v02r01.

Method PM-G (Measurement using a gated RF average power meter):

1. Measurement is performed using a wideband RF power meter.
2. The EUT is configured to transmit at its maximum power control level.
3. Measure the average power of the transmitter
4. Since the measurement is made only during the ON time of the transmitter, no duty cycle correction factor is required.

3.2.4 Test Setup

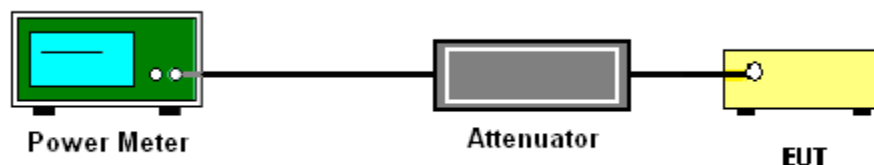

3.2.5 Test Result of Maximum Conducted Output Power

Please refer to Appendix A.



3.3 Power Spectral Density Measurement

3.3.1 Limit of Power Spectral Density

For the band 5.725–5.85 GHz, the maximum power spectral density shall not exceed 30 dBm in any 500-kHz band.

If transmitting antennas of directional gain greater than 6 dBi are used, the peak output power shall be reduced by the amount in dB that the directional gain of the antenna exceeds 6 dBi.

3.3.2 Measuring Instruments

See list of measuring equipment of this test report.

3.3.3 Test Procedures

The testing follows FCC KDB 789033 D02 General UNII Test Procedures New Rules v02r01. Section F) Maximum power spectral density.

Method SA-3

(power averaging (rms) detection with max hold):

- Set span to encompass the entire emission bandwidth (EBW) of the signal.
 - Set RBW = 300 kHz.
 - Set VBW \geq 1 MHz.
 - Number of points in sweep \geq 2 Span / RBW.
 - Sweep time \leq (number of points in sweep) \times T, when duty cycle is less than 98 percent where T is the minimum transmission duration over which the transmitter is on and is transmitting at its maximum power control level for the tested mode of operation.
 - Detector = power averaging (rms).
 - Trace mode = max hold.
 - Allow max hold to run for at least 60 seconds, or longer as needed to allow the trace to stabilize.
1. The RF output of EUT was connected to the spectrum analyzer by a low loss cable.
 2. Each plot has already offset with cable loss, and attenuator loss. Measure the PPSD and record it.



3.4 Unwanted Emissions Measurement

This section is to measure unwanted emissions through radiated measurement for band edge spurious emissions and out of band emissions measurement.

3.4.1 Limit of Unwanted Emissions

- (1) For transmitters operating in the 5.725-5.85 GHz band:
 15.407(b)(4)(i) All emissions shall be limited to a level of -27 dBm/MHz at 75 MHz or more above or below the band edge increasing linearly to 10 dBm/MHz at 25 MHz above or below the band edge, and from 25 MHz above or below the band edge increasing linearly to a level of 15.6 dBm/MHz at 5 MHz above or below the band edge, and from 5 MHz above or below the band edge increasing linearly to a level of 27 dBm/MHz at the band edge.
- (2) Unwanted spurious emissions fallen in restricted bands shall comply with the general field strength limits as below table,

Frequency (MHz)	Field Strength (microvolts/meter)	Measurement Distance (meters)
0.009 – 0.490	2400/F(kHz)	300
0.490 – 1.705	24000/F(kHz)	30
1.705 – 30.0	30	30
30 – 88	100	3
88 – 216	150	3
216 - 960	200	3
Above 960	500	3

Note: The following formula is used to convert the EIRP to field strength.

$$E = \frac{1000000\sqrt{30P}}{3} \mu\text{V/m, where P is the eirp (Watts)}$$



EIRP (dBm)	Field Strength at 3m (dBμV/m)
- 27	68.3

(3) KDB789033 D02 v02r01 G)2)c)

- (i) Sections 15.407(b)(1-3) specifies the unwanted emissions limit for the U-NII-1 and U-NII-2 bands. As specified, emissions above 1000 MHz that are outside of the restricted bands are subject to a peak emission limit of -27 dBm/MHz.
- (ii) Section 15.407(b)(4) specifies the unwanted emissions limit for the U-NII-3 band. A band emissions mask is specified in Section 15.407(b)(4)(i). The emission limits are based on the use of a peak detector.

3.4.2 Measuring Instruments

See list of measuring equipment of this test report.

3.4.3 Test Procedures

1. The testing follows FCC KDB 789033 D02 General UNII Test Procedures New Rules v02r01. Section G) Unwanted emissions measurement.

(1) Procedure for Unwanted Emissions Measurements Below 1000MHz

- RBW = 120 kHz
- VBW = 300 kHz
- Detector = Peak
- Trace mode = max hold

(2) Procedure for Peak Unwanted Emissions Measurements Above 1000 MHz

- RBW = 1 MHz
- VBW ≥ 3 MHz
- Detector = Peak
- Sweep time = auto
- Trace mode = max hold

(3) Procedures for Average Unwanted Emissions Measurements Above 1000MHz

- RBW = 1 MHz
- VBW = 10 Hz, when duty cycle is no less than 98 percent.
- VBW ≥ 1/T, when duty cycle is less than 98 percent where T is the minimum transmission duration over which the transmitter is on and is transmitting at its maximum power control level for the tested mode of operation.



2. The EUT was placed on a turntable with 0.8 meter for frequency below 1GHz and 1.5 meter for frequency above 1GHz respectively above ground.
3. The EUT was set 3 meters from the interference receiving antenna which was mounted on the top of a variable height antenna tower.
4. The antenna is a broadband antenna and its height is adjusted between one meter and four meters above ground to find the maximum value of the field strength for both horizontal polarization and vertical polarization of the antenna.
5. For each suspected emission, the EUT was arranged to its worst case and then adjust the antenna tower (from 1 m to 4 m) and turntable (from 0 degree to 360 degrees) to find the maximum reading.
6. For testing below 1GHz, if the emission level of the EUT in peak mode was 3 dB lower than the limit specified, then peak values of EUT will be reported, otherwise, the emissions will be repeated one by one using the CISPR quasi-peak method and reported.
7. For testing above 1GHz, the emission level of the EUT in peak mode was 20dB lower than average limit (that means the emission level in average mode also complies with the limit in average mode), then peak values of EUT will be reported, otherwise, the emissions will be measured in average mode again and reported.

3.4.4 Test Setup

For radiated emissions below 30MHz

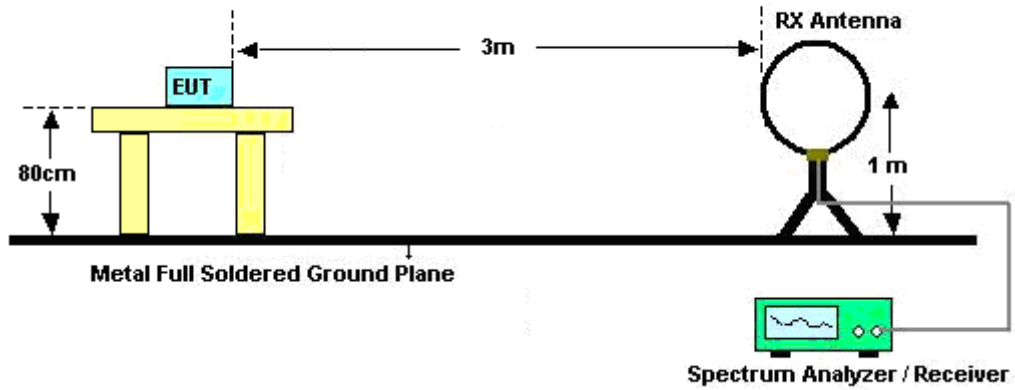

For radiated emissions from 30MHz to 1GHz

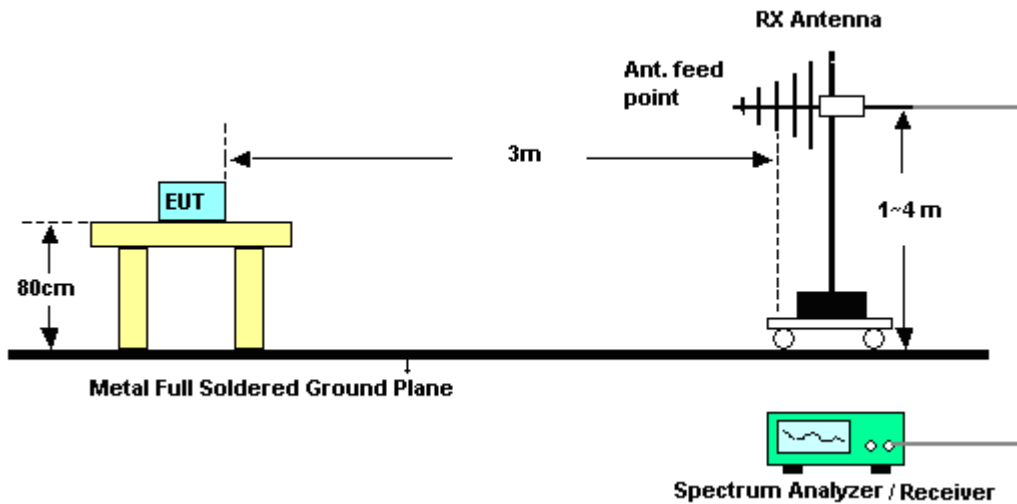

For radiated emissions above 1GHz

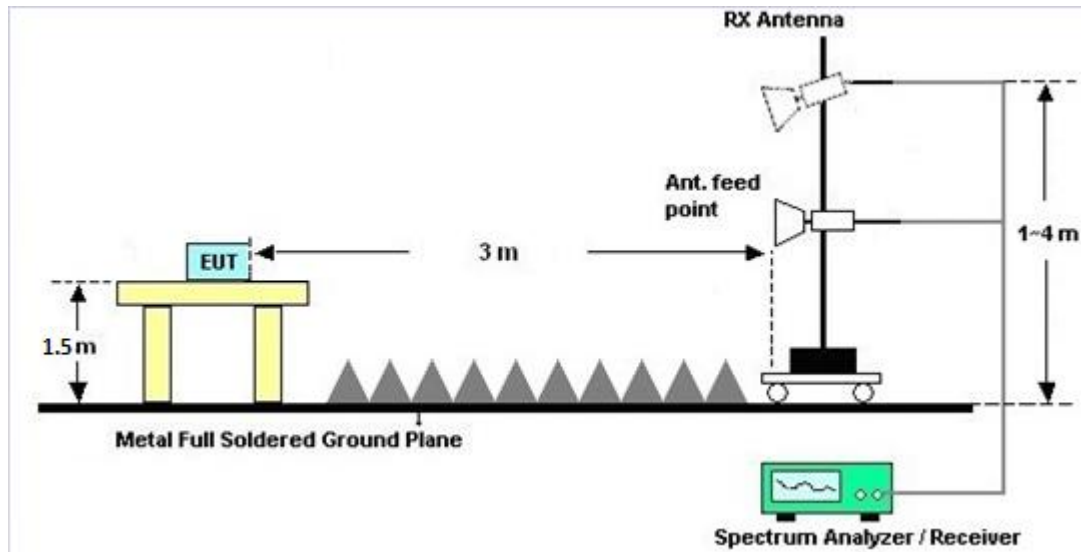

3.4.5 Test Results of Radiated Emissions (9 kHz ~ 30 MHz)

The low frequency, which started from 9 kHz to 30MHz, was pre-scanned and the result which was 20dB lower than the limit line was not reported.

There is a comparison data of both open-field test site and alternative test site - semi-Anechoic chamber according to 414788 D01 Radiated Test Site v01r01, and the result came out very similar.

3.4.6 Test Result of Radiated Band Edges

Please refer to Appendix C and D.

3.4.7 Duty Cycle

Please refer to Appendix E.

3.4.8 Test Result of Unwanted Radiated Emission (30MHz ~ 10th Harmonic)

Please refer to Appendix C and D.



3.5 AC Conducted Emission Measurement

3.5.1 Limit of AC Conducted Emission

For equipment that is designed to be connected to the public utility (AC) power line, the radio frequency voltage that is conducted back onto the AC power line on any frequency or frequencies within the band 150 kHz to 30 MHz shall not exceed the limits in the following table.

Frequency of emission (MHz)	Conducted limit (dB μ V)	
	Quasi-peak	Average
0.15-0.5	66 to 56*	56 to 46*
0.5-5	56	46
5-30	60	50

*Decreases with the logarithm of the frequency.

3.5.2 Measuring Instruments

See list of measuring equipment of this test report.

3.5.3 Test Procedures

1. The EUT was placed 0.4 meter from the conducting wall of the shielding room was kept at least 80 centimeters from any other grounded conducting surface.
2. Connect EUT to the power mains through a line impedance stabilization network (LISN).
3. All the support units are connecting to the other LISN.
4. The LISN provides 50 ohm coupling impedance for the measuring instrument.
5. The FCC states that a 50 ohm, 50 microhenry LISN should be used.
6. Both sides of AC line were checked for maximum conducted interference.
7. The frequency range from 150 kHz to 30 MHz was searched.
8. Set the test-receiver system to Peak Detect Function and specified bandwidth with Maximum Hold Mode.

3.5.4 Test Setup

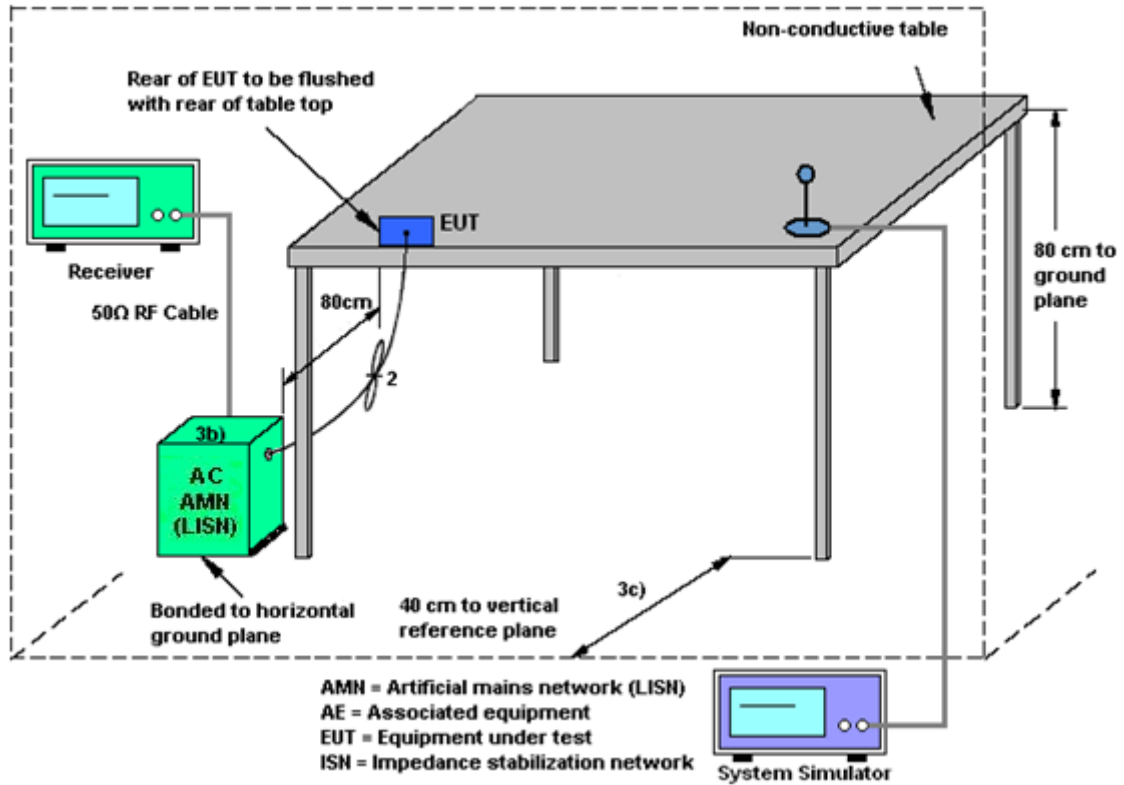

3.5.5 Test Result of AC Conducted Emission

Please refer to Appendix B.



3.6 Automatically Discontinue Transmission

3.6.1 Limit of Automatically Discontinue Transmission

The device shall automatically discontinue transmission in case of either absence of information to transmit or operational failure. These provisions are not intended to preclude the transmission of control or signaling information or the use of repetitive codes used by certain digital technologies to complete frame or burst intervals. Applicants shall include in their application for equipment authorization to describe how this requirement is met.

3.6.2 Measuring Instruments

See list of measuring equipment of this test report.

3.6.3 Test Result of Automatically Discontinue Transmission

While the EUT is not transmitting any information, the EUT can automatically discontinue transmission and become standby mode for power saving. The EUT can detect the controlling signal of ACK message transmitting from remote device and verify whether it shall resend or discontinue transmission.



3.7 Antenna Requirements

3.7.1 Standard Applicable

If transmitting antenna directional gain is greater than 6 dBi, both the peak transmit power and the peak power spectral density shall be reduced by the amount in dB that the directional gain of the antenna exceeds 6 dBi.

3.7.2 Antenna Anti-Replacement Construction

An embedded-in antenna design is used.

3.7.3 Antenna Gain

The antenna peak gain of EUT is less than 6 dBi. Therefore, it is not necessary to reduce maximum peak output power limit.



4 List of Measuring Equipment

Instrument	Manufacturer	Model No.	Serial No.	Characteristics	Calibration Date	Test Date	Due Date	Remark
Loop Antenna	Rohde & Schwarz	HFH2-Z2	100488	9 kHz~30 MHz	Jan. 09, 2020	May 01, 2020~ May 19, 2020	Jan. 08, 2021	Radiation (03CH15-HY)
Bilog Antenna	TESEQ	CBL6111D&0 0800N1D01N- 06	41912&05	30MHz to 1GHz	Feb. 09, 2020	May 01, 2020~ May 19, 2020	Feb. 08, 2021	Radiation (03CH15-HY)
Horn Antenna	SCHWARZBE CK	BBHA 9120 D	9120D-211 4	1-18GHz	Jul. 31, 2019	May 01, 2020~ May 19, 2020	Jul. 30, 2020	Radiation (03CH15-HY)
SHF-EHF Horn Antenna	SCHWARZBE CK	BBHA 9170	BBHA9170 584	18GHz- 40GHz	Dec. 10, 2019	May 01, 2020~ May 19, 2020	Dec. 09, 2020	Radiation (03CH15-HY)
Amplifier	SONOMA	310N	363440	9kHz~1GHz	Dec. 27, 2019	May 01, 2020~ May 19, 2020	Dec. 26, 2020	Radiation (03CH15-HY)
Preamplifier	Jet-Power	JPA0118-55-3 03	171000180 0055007	1GHz~18GHz	Mar. 31, 2020	May 01, 2020~ May 19, 2020	Mar. 30, 2021	Radiation (03CH15-HY)
Preamplifier	Keysight	83017A	MY532701 95	1GHz~26.5GHz	Aug. 23, 2019	May 01, 2020~ May 19, 2020	Aug. 22, 2020	Radiation (03CH15-HY)
Preamplifier	EMEC	EM18G40G	060715	18GHz ~ 40GHz	Dec. 13, 2019	May 01, 2020~ May 19, 2020	Dec. 12, 2020	Radiation (03CH15-HY)
EMI Test Receiver	Keysight	N9038A (MXE)	MY541300 85	20MHz~8.4GHz	Nov. 01, 2019	May 01, 2020~ May 19, 2020	Oct. 31, 2020	Radiation (03CH15-HY)
EMI Test Receiver	Rohde & Schwarz	ESU26	100390	20Hz~26.5GHz	Feb. 25, 2020	May 01, 2020~ May 19, 2020	Feb. 24, 2021	Radiation (03CH15-HY)
Antenna Mast	ChainTek	MBS-520-1	N/A	1m~4m	N/A	May 01, 2020~ May 19, 2020	N/A	Radiation (03CH15-HY)
Turn Table	ChainTek	T-200-S-1	N/A	0~360 Degree	N/A	May 01, 2020~ May 19, 2020	N/A	Radiation (03CH15-HY)
Software	Audix	E3 6.2009-8-24 (k5)	RK-00045 1	N/A	N/A	May 01, 2020~ May 19, 2020	N/A	Radiation (03CH15-HY)
RF Cable	HUBER + SUHNER	SUCOFLEX 104	MY36980/ 4	30M-18G	Apr. 14, 2020	May 01, 2020~ May 19, 2020	Apr. 13, 2021	Radiation (03CH15-HY)
RF Cable	HUBER + SUHNER	SUCOFLEX 104	MY9838/4 PE	30M-18G	Apr. 14, 2020	May 01, 2020~ May 19, 2020	Apr. 13, 2021	Radiation (03CH15-HY)
RF Cable	HUBER + SUHNER	SUCOFLEX 104	MY802430 /4	30M~18GHz	Apr. 14, 2020	May 01, 2020~ May 19, 2020	Apr. 13, 2021	Radiation (03CH15-HY)
RF Cable	HUBER + SUHNER	SUCOFLEX 102	505134/2	30MHz-40GHz	Feb. 25, 2020	May 01, 2020~ May 19, 2020	Feb. 24, 2021	Radiation (03CH15-HY)
RF Cable	HUBER + SUHNER	SUCOFLEX 102	800740/2	30MHz-40GHz	Feb. 25, 2020	May 01, 2020~ May 19, 2020	Feb. 24, 2021	Radiation (03CH15-HY)
Filter	Wainwright	WLK4-1000-1 530-8000-40S S	SN4	1.53G Low Pass	Jul. 04, 2019	May 01, 2020~ May 19, 2020	Jul. 03, 2020	Radiation (03CH15-HY)
Filter	Wainwright	WHKX8-5872. 5-6750-18000 -40ST	SN6	6.75GHz High Pass Filter	Jul. 02, 2019	May 01, 2020~ May 19, 2020	Jul. 01, 2020	Radiation (03CH15-HY)



Instrument	Manufacturer	Model No.	Serial No.	Characteristics	Calibration Date	Test Date	Due Date	Remark
Hygrometer	Testo	608-H2	41410069	N/A	Jun. 17, 2019	Apr. 24, 2020~ Jun. 02, 2020	Jun. 16, 2020	Conducted (TH05-HY)
Power Sensor	DARE	RPR3006W	16I00054S NO10	10MHz~6GHz	Dec. 23, 2019	Apr. 24, 2020~ Jun. 02, 2020	Dec. 22, 2020	Conducted (TH05-HY)
Spectrum Analyzer	Rohde & Schwarz	FSP40	100055	9kHz-40GHz	Aug. 14, 2019	Apr. 24, 2020~ Jun. 02, 2020	Aug. 13, 2020	Conducted (TH05-HY)
Switch Box & RF Cable	Burgeon	ETF-058	EC130048 4	N/A	Aug. 22, 2019	Apr. 24, 2020~ Jun. 02, 2020	Aug. 21, 2020	Conducted (TH05-HY)
AC Power Source	ChainTek	APC-1000W	N/A	N/A	N/A	Apr. 28, 2020	N/A	Conduction (CO05-HY)
EMI Test Receiver	Rohde & Schwarz	ESR3	102388	9kHz~3.6GHz	Nov. 15, 2019	Apr. 28, 2020	Nov. 14, 2020	Conduction (CO05-HY)
Hygrometer	Testo	608-H1	34913912	N/A	Nov. 07, 2019	Apr. 28, 2020	Nov. 06, 2020	Conduction (CO05-HY)
LISN	Rohde & Schwarz	ENV216	100080	9kHz~30MHz	Nov. 20, 2019	Apr. 28, 2020	Nov. 19, 2020	Conduction (CO05-HY)
Software	Rohde & Schwarz	EMC32 V10.30	N/A	N/A	N/A	Apr. 28, 2020	N/A	Conduction (CO05-HY)
LF Cable	HUBER + SUHNER	RG-214/U	LF01	N/A	Jan. 02, 2020	Apr. 28, 2020	Jan. 01, 2021	Conduction (CO05-HY)
Pulse Limiter	Rohde & Schwarz	ESH3-Z2	100851	N/A	Jan. 02, 2020	Apr. 28, 2020	Jan. 01, 2021	Conduction (CO05-HY)



5 Uncertainty of Evaluation

Uncertainty of Conducted Emission Measurement (150kHz ~ 30MHz)

Measuring Uncertainty for a Level of Confidence of 95% ($U = 2Uc(y)$)	2.3
---	-----

Uncertainty of Radiated Emission Measurement (30 MHz ~ 1000 MHz)

Measuring Uncertainty for a Level of Confidence of 95% ($U = 2Uc(y)$)	5.0
---	-----

Uncertainty of Radiated Emission Measurement (1000 MHz ~ 18000 MHz)

Measuring Uncertainty for a Level of Confidence of 95% ($U = 2Uc(y)$)	5.4
---	-----

Uncertainty of Radiated Emission Measurement (18000 MHz ~ 40000 MHz)

Measuring Uncertainty for a Level of Confidence of 95% ($U = 2Uc(y)$)	5.0
---	-----

Appendix A. Test Result of Conducted Test Items

Test Engineer:	Eason Huang/junyu	Temperature:	21~25	°C
Test Date:	2020/4/24~2020/6/02	Relative Humidity:	51~54	%

TEST RESULTS DATA
6dB and 26dB EBW and 99% OBW

Band IV single antenna												
Mod.	Data Rate	NTX	CH.	Freq. (MHz)	99% Bandwidth (MHz)		26dB Bandwidth (MHz)		6 dB Bandwidth (MHz)		6 dB Bandwidth Min. Limit (MHz)	Pass/Fail
					Ant 1	Ant 2	Ant 1	Ant 2	Ant 1	Ant 2		
11a	6Mbps	1	149	5745	16.70	-	24.85	-	15.10	-	0.5	Pass
11a	6Mbps	1	157	5785	16.75	-	24.35	-	15.35	-	0.5	Pass
11a	6Mbps	1	165	5825	16.70	-	24.45	-	15.15	-	0.5	Pass
HT20	MCS0	1	149	5745	17.90	-	25.25	-	15.10	-	0.5	Pass
HT20	MCS0	1	157	5785	17.95	-	25.10	-	15.10	-	0.5	Pass
HT20	MCS0	1	165	5825	17.90	-	25.35	-	15.10	-	0.5	Pass
HT40	MCS0	1	151	5755	36.70	-	42.12	-	35.73	-	0.5	Pass
HT40	MCS0	1	159	5795	36.70	-	42.30	-	35.10	-	0.5	Pass
VHT80	MCS0	1	155	5775	77.04	-	83.20	-	75.20	-	0.5	Pass

TEST RESULTS DATA
Average Power Table

Band IV single antenna									
Mod.	Data Rate	NTX	CH.	Freq. (MHz)	Average Conducted Power (dBm)		FCC Conducted Power Limit (dBm)		Pass/Fail
					Ant 1	SUM	Ant 1	Ant 1	
11a	6Mbps	1	149	5745	18.50		30.00	2.00	Pass
11a	6Mbps	1	157	5785	18.30		30.00	2.00	Pass
11a	6Mbps	1	165	5825	18.50		30.00	2.00	Pass
HT20	MCS0	1	149	5745	18.50		30.00	2.00	Pass
HT20	MCS0	1	157	5785	18.50		30.00	2.00	Pass
HT20	MCS0	1	165	5825	18.40		30.00	2.00	Pass
HT40	MCS0	1	151	5755	17.30		30.00	2.00	Pass
HT40	MCS0	1	159	5795	17.50		30.00	2.00	Pass
VHT20	MCS0	1	149	5745	18.40		30.00	2.00	Pass
VHT20	MCS0	1	157	5785	18.40		30.00	2.00	Pass
VHT20	MCS0	1	165	5825	18.30		30.00	2.00	Pass
VHT40	MCS0	1	151	5755	17.20		30.00	2.00	Pass
VHT40	MCS0	1	159	5795	17.40		30.00	2.00	Pass
VHT80	MCS0	1	155	5775	17.20		30.00	2.00	Pass

TEST RESULTS DATA
Power Spectral Density

Band IV single antenna														
Mod.	Data Rate	NTX	CH.	Freq. (MHz)	10log (500kHz /RBW) Factor (dB)		Average Power Density (dBm/500kHz)			Average PSD Limit (dBm/500kHz)		DG (dBi)		Pass /Fail
					Ant 1	Ant 2	Ant 1	Ant 2	SUM	Ant 1	Ant 2	Ant 1	Ant 2	
11a	6Mbps	1	149	5745	2.22	-	9.57	-		30.00	30.00	2.00	0.00	Pass
11a	6Mbps	1	157	5785	2.22	-	9.23	-		30.00	30.00	2.00	0.00	Pass
11a	6Mbps	1	165	5825	2.22	-	9.75	-		30.00	30.00	2.00	0.00	Pass
HT20	MCS0	1	149	5745	2.22	-	9.80	-		30.00	30.00	2.00	0.00	Pass
HT20	MCS0	1	157	5785	2.22	-	10.42	-		30.00	30.00	2.00	0.00	Pass
HT20	MCS0	1	165	5825	2.22	-	9.98	-		30.00	30.00	2.00	0.00	Pass
HT40	MCS0	1	151	5755	2.22	-	4.53	-		30.00	30.00	2.00	0.00	Pass
HT40	MCS0	1	159	5795	2.22	-	4.85	-		30.00	30.00	2.00	0.00	Pass
VHT80	MCS0	1	155	5775	2.22	-	2.96	-		30.00	30.00	2.00	0.00	Pass



Appendix B. AC Conducted Emission Test Results

Test Engineer :	Tom Lee	Temperature :	21~23°C
		Relative Humidity :	40~43%

EUT Information

Report NO : 042038
 Test Mode : Mode 1
 Test Voltage : 120Vac/60Hz
 Phase : Line

Full Spectrum

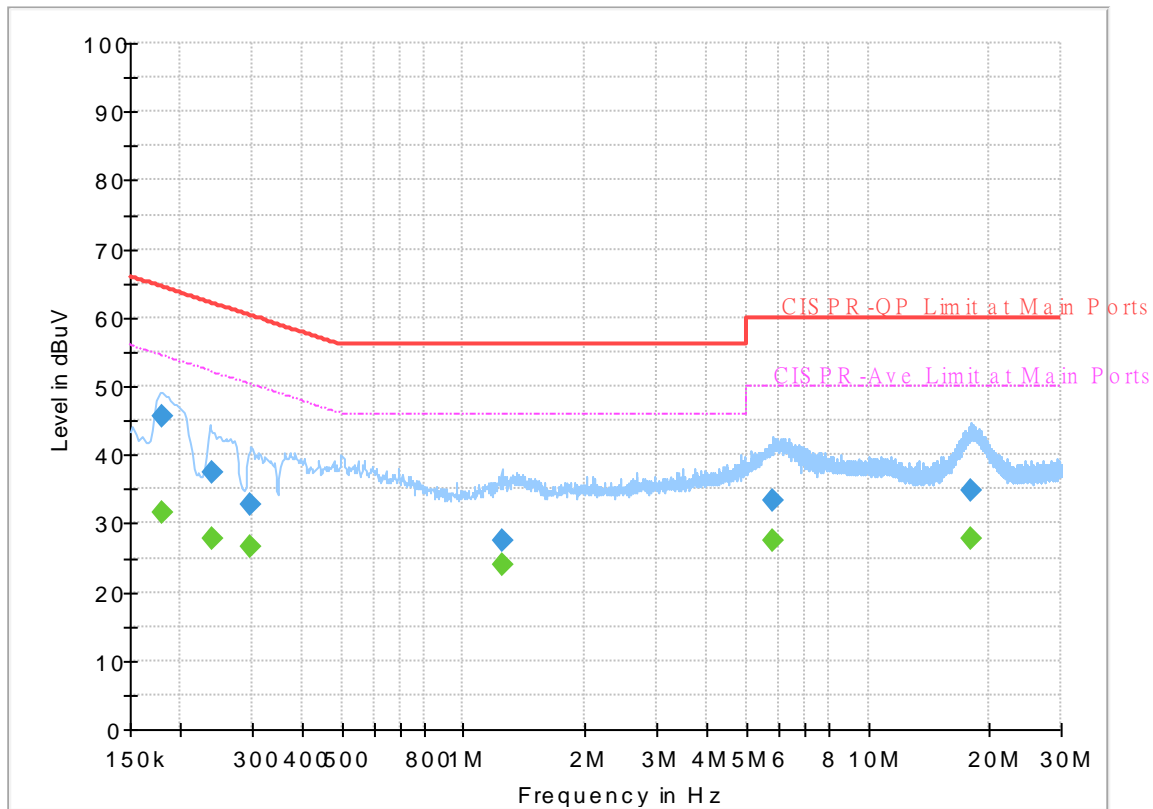

Final_Result

Frequency (MHz)	QuasiPeak (dBuV)	CAverage (dBuV)	Limit (dBuV)	Margin (dB)	Line	Filter	Corr. (dB)
0.179340	---	31.65	54.52	22.87	L1	OFF	19.6
0.179340	45.49	---	64.52	19.03	L1	OFF	19.6
0.240000	---	27.92	52.10	24.18	L1	OFF	19.6
0.240000	37.48	---	62.10	24.62	L1	OFF	19.6
0.297330	---	26.55	50.32	23.77	L1	OFF	19.6
0.297330	32.87	---	60.32	27.45	L1	OFF	19.6
1.242330	---	23.91	46.00	22.09	L1	OFF	19.6
1.242330	27.46	---	56.00	28.54	L1	OFF	19.6
5.829000	---	27.39	50.00	22.61	L1	OFF	19.9
5.829000	33.36	---	60.00	26.64	L1	OFF	19.9
18.054870	---	27.79	50.00	22.21	L1	OFF	20.3
18.054870	34.86	---	60.00	25.14	L1	OFF	20.3

EUT Information

Report NO : 042038
 Test Mode : Mode 1
 Test Voltage : 120Vac/60Hz
 Phase : Neutral

Full Spectrum

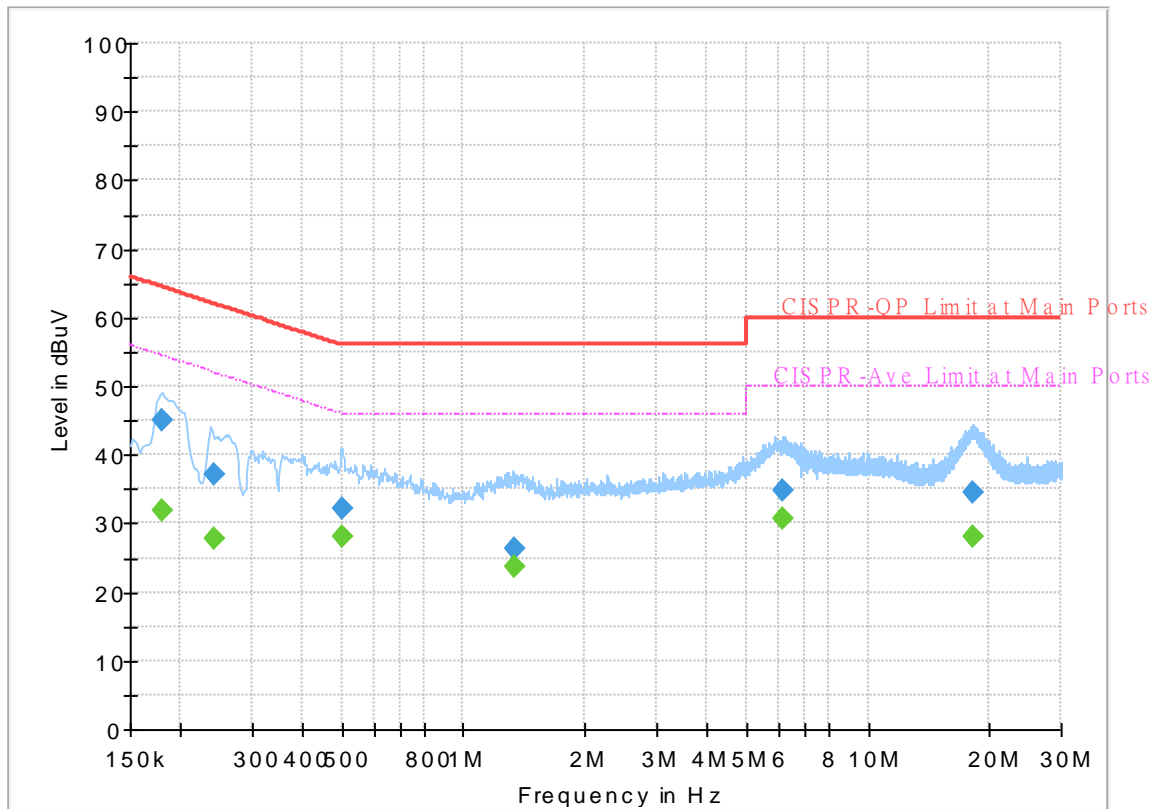

Final_Result

Frequency (MHz)	QuasiPeak (dBuV)	CAverage (dBuV)	Limit (dBuV)	Margin (dB)	Line	Filter	Corr. (dB)
0.180150	45.08	---	64.48	19.40	N	OFF	19.6
0.180150	---	31.83	54.48	22.65	N	OFF	19.6
0.242250	37.08	---	62.02	24.94	N	OFF	19.6
0.242250	---	27.71	52.02	24.31	N	OFF	19.6
0.500550	32.10	---	56.00	23.90	N	OFF	19.6
0.500550	---	28.15	46.00	17.85	N	OFF	19.6
1.333500	26.25	---	56.00	29.75	N	OFF	19.6
1.333500	---	23.56	46.00	22.44	N	OFF	19.6
6.144000	34.74	---	60.00	25.26	N	OFF	19.9
6.144000	---	30.56	50.00	19.44	N	OFF	19.9
18.183750	34.54	---	60.00	25.46	N	OFF	20.3
18.183750	---	28.08	50.00	21.92	N	OFF	20.3



Appendix C. Radiated Spurious Emission

Test Engineer :	Leo Lee, Mancy Chou and Bigshow Wang	Temperature :	22.1~23.1°C
		Relative Humidity :	55~60%

Band 4 - 5725~5850MHz
WIFI 802.11a (Band Edge @ 3m)

WIFI Ant.	Note	Frequency (MHz)	Level (dBµV/m)	Over Limit (dB)	Limit Line (dBµV/m)	Read Level (dBµV)	Antenna Factor (dB/m)	Path Loss (dB)	Preamp Factor (dB)	Ant Pos (cm)	Table Pos (deg)	Peak Avg. (P/A)	Pol. (H/V)	
802.11a CH 149 5745MHz		5624.8	51.48	-16.72	68.2	39.25	31.85	10.89	30.51	272	25	P	H	
		5681.4	51.88	-39.59	91.47	39.61	31.93	10.88	30.54	272	25	P	H	
		5702	52.1	-53.66	105.76	39.79	32	10.87	30.56	272	25	P	H	
		5725	52.05	-70.15	122.2	39.75	32	10.87	30.57	272	25	P	H	
	*	5745	102.37	-	-	90.09	32	10.86	30.58	272	25	P	H	
	*	5745	94.91	-	-	82.63	32	10.86	30.58	272	25	A	H	
														H
														H
			5608.2	51.57	-16.63	68.2	39.29	31.88	10.9	30.5	329	57	P	V
			5688.6	51.91	-44.88	96.79	39.63	31.95	10.88	30.55	329	57	P	V
			5703.4	51.85	-54.3	106.15	39.54	32	10.87	30.56	329	57	P	V
			5721.6	55.98	-58.47	114.45	43.68	32	10.87	30.57	329	57	P	V
	*	5745	107.51	-	-	95.23	32	10.86	30.58	329	57	P	V	
	*	5745	100	-	-	87.72	32	10.86	30.58	329	57	A	V	
														V
													V	



WIFI Ant. 1	Note	Frequency (MHz)	Level (dBμV/m)	Over Limit (dB)	Limit Line (dBμV/m)	Read Level (dBμV)	Antenna Factor (dB/m)	Path Loss (dB)	Preamp Factor (dB)	Ant Pos (cm)	Table Pos (deg)	Peak Avg. (P/A)	Pol. (H/V)
		5627	52.04	-16.16	68.2	39.81	31.85	10.89	30.51	258	27	P	H
		5666	51.81	-28.27	80.08	39.6	31.86	10.88	30.53	258	27	P	H
		5711	51.06	-57.22	108.28	38.75	32	10.87	30.56	258	27	P	H
		5722.2	50.81	-65.01	115.82	38.51	32	10.87	30.57	258	27	P	H
	*	5785	102.49	-	-	90.11	32.14	10.85	30.61	258	27	P	H
	*	5785	94.7	-	-	82.32	32.14	10.85	30.61	258	27	A	H
		5854.2	51.47	-61.15	112.62	38.91	32.22	10.99	30.65	258	27	P	H
		5861.8	51.63	-57.26	108.89	39.02	32.25	11.01	30.65	258	27	P	H
		5877.4	51.9	-51.52	103.42	39.21	32.31	11.04	30.66	258	27	P	H
		5942.4	51.98	-16.22	68.2	38.99	32.48	11.21	30.7	258	27	P	H
													H
													H
802.11a													
CH 157													
5785MHz		5637.4	51.86	-16.34	68.2	39.66	31.83	10.89	30.52	301	57	P	V
		5676.6	51.49	-36.43	87.92	39.24	31.91	10.88	30.54	301	57	P	V
		5706.2	52.04	-54.9	106.94	39.73	32	10.87	30.56	301	57	P	V
		5724.4	52.82	-68.01	120.83	40.52	32	10.87	30.57	301	57	P	V
	*	5785	107.43	-	-	95.05	32.14	10.85	30.61	301	57	P	V
	*	5785	99.82	-	-	87.44	32.14	10.85	30.61	301	57	A	V
		5851	52.28	-67.64	119.92	39.75	32.2	10.98	30.65	301	57	P	V
		5860.6	52.59	-56.64	109.23	40	32.24	11	30.65	301	57	P	V
		5882.2	52.98	-46.87	99.85	40.26	32.33	11.06	30.67	301	57	P	V
		5937.4	52.98	-15.22	68.2	40.01	32.47	11.2	30.7	301	57	P	V
													V
													V



WiFi Ant. 1	Note	Frequency (MHz)	Level (dBμV/m)	Over Limit (dB)	Limit Line (dBμV/m)	Read Level (dBμV)	Antenna Factor (dB/m)	Path Loss (dB)	Preamp Factor (dB)	Ant Pos (cm)	Table Pos (deg)	Peak Avg. (P/A)	Pol. (H/V)	
802.11a CH 165 5825MHz	*	5825	101.19	-	-	88.71	32.2	10.91	30.63	253	25	P	H	
	*	5825	93.72	-	-	81.24	32.2	10.91	30.63	253	25	A	H	
		5851	51.87	-68.05	119.92	39.34	32.2	10.98	30.65	253	25	P	H	
		5862.6	51.98	-56.69	108.67	39.37	32.25	11.01	30.65	253	25	P	H	
		5903.2	52.83	-31.46	84.29	39.99	32.41	11.11	30.68	253	25	P	H	
		5949.2	53.83	-14.37	68.2	40.82	32.5	11.22	30.71	253	25	P	H	
														H
														H
	*	5825	107.32	-	-	94.84	32.2	10.91	30.63	293	58	P	V	
	*	5825	99.72	-	-	87.24	32.2	10.91	30.63	293	58	A	V	
		5853.4	58.41	-56.04	114.45	45.87	32.21	10.98	30.65	293	58	P	V	
		5859.2	55.4	-54.22	109.62	42.81	32.24	11	30.65	293	58	P	V	
		5896	53.95	-35.67	89.62	41.16	32.38	11.09	30.68	293	58	P	V	
		5937.8	52.75	-15.45	68.2	39.77	32.48	11.2	30.7	293	58	P	V	
														V
														V
													V	
Remark	1. No other spurious found. 2. All results are PASS against Peak and Average limit line.													



Band 4 5725~5850MHz
WIFI 802.11a (Harmonic @ 3m)

WIFI Ant. 1	Note	Frequency (MHz)	Level (dBμV/m)	Over Limit (dB)	Limit Line (dBμV/m)	Read Level (dBμV)	Antenna Factor (dB/m)	Path Loss (dB)	Preamp Factor (dB)	Ant Pos (cm)	Table Pos (deg)	Peak Avg. (P/A)	Pol. (H/V)	
802.11a CH 149 5745MHz		11490	49.66	-24.34	74	55.92	40.48	14.85	61.59	100	0	P	H	
		17235	50.3	-17.9	68.2	49.51	40.94	18.67	58.82	100	0	P	H	
													H	
													H	
			11490	49.42	-24.58	74	55.68	40.48	14.85	61.59	100	0	P	V
			17235	51.26	-16.94	68.2	50.47	40.94	18.67	58.82	100	0	P	V
														V
802.11a CH 157 5785MHz		11570	49.97	-24.03	74	56.39	40.29	14.91	61.62	100	0	P	H	
		17355	51.27	-16.93	68.2	49.26	41.75	18.79	58.53	100	0	P	H	
													H	
													H	
			11570	49.4	-24.6	74	55.82	40.29	14.91	61.62	100	0	P	V
			17355	50.96	-17.24	68.2	48.95	41.75	18.79	58.53	100	0	P	V
														V
802.11a CH 165 5825MHz		11650	49.02	-24.98	74	55.84	39.85	14.96	61.63	100	0	P	H	
		17475	51.34	-16.86	68.2	48.21	42.5	18.86	58.23	100	0	P	H	
													H	
													H	
			11650	48.79	-25.21	74	55.61	39.85	14.96	61.63	100	0	P	V
			17475	50.67	-17.53	68.2	47.54	42.5	18.86	58.23	100	0	P	V
														V
Remark	1. No other spurious found.													
	2. All results are PASS against Peak and Average limit line.													



Band 4 5725~5850MHz
WIFI 802.11n HT20 (Band Edge @ 3m)

WIFI Ant. 1	Note	Frequency (MHz)	Level (dBμV/m)	Over Limit (dB)	Limit Line (dBμV/m)	Read Level (dBμV)	Antenna Factor (dB/m)	Path Loss (dB)	Preamp Factor (dB)	Ant Pos (cm)	Table Pos (deg)	Peak Avg. (P/A)	Pol. (H/V)	
802.11n HT20 CH 149 5745MHz		5622	52.41	-15.79	68.2	40.17	31.86	10.89	30.51	278	26	P	H	
		5699	55.66	-48.8	104.46	43.34	32	10.87	30.55	278	26	P	H	
		5706.2	57.36	-49.58	106.94	45.05	32	10.87	30.56	278	26	P	H	
		5724.6	54.38	-66.91	121.29	42.08	32	10.87	30.57	278	26	P	H	
	*	5745	104.01	-	-	91.73	32	10.86	30.58	278	26	P	H	
	*	5745	94.64	-	-	82.36	32	10.86	30.58	278	26	A	H	
														H
														H
			5622.2	51.93	-16.27	68.2	39.69	31.86	10.89	30.51	290	57	P	V
			5688	55.83	-40.52	96.35	43.55	31.95	10.88	30.55	290	57	P	V
			5710.4	60.16	-47.95	108.11	47.85	32	10.87	30.56	290	57	P	V
			5724.6	60.29	-61	121.29	47.99	32	10.87	30.57	290	57	P	V
	*		5745	108.33	-	-	96.05	32	10.86	30.58	290	57	P	V
	*		5745	99.35	-	-	87.07	32	10.86	30.58	290	57	A	V
													V	
													V	



WIFI Ant. 1	Note	Frequency (MHz)	Level (dBμV/m)	Over Limit (dB)	Limit Line (dBμV/m)	Read Level (dBμV)	Antenna Factor (dB/m)	Path Loss (dB)	Preamp Factor (dB)	Ant Pos (cm)	Table Pos (deg)	Peak Avg. (P/A)	Pol. (H/V)
		5646.4	52.79	-15.41	68.2	40.61	31.81	10.89	30.52	269	26	P	H
		5651.2	52.41	-16.68	69.09	40.24	31.8	10.89	30.52	269	26	P	H
		5706.8	53.29	-53.82	107.11	40.98	32	10.87	30.56	269	26	P	H
		5723.4	52.44	-66.11	118.55	40.14	32	10.87	30.57	269	26	P	H
	*	5785	103.73	-	-	91.35	32.14	10.85	30.61	269	26	P	H
	*	5785	94.36	-	-	81.98	32.14	10.85	30.61	269	26	A	H
		5850	52.25	-69.95	122.2	39.72	32.2	10.98	30.65	269	26	P	H
		5855.2	52.44	-58.3	110.74	39.88	32.22	10.99	30.65	269	26	P	H
		5911.8	52.77	-25.17	77.94	39.91	32.42	11.13	30.69	269	26	P	H
		5932	53.65	-14.55	68.2	40.71	32.46	11.18	30.7	269	26	P	H
802.11n		5614	53.4	-14.8	68.2	41.14	31.87	10.89	30.5	303	57	P	V
HT20													H
CH 157		5668	52.57	-28.99	81.56	40.35	31.87	10.88	30.53	303	57	P	V
5785MHz		5719	56	-54.52	110.52	43.7	32	10.87	30.57	303	57	P	V
		5724.2	56.09	-64.29	120.38	43.79	32	10.87	30.57	303	57	P	V
	*	5785	108.94	-	-	96.56	32.14	10.85	30.61	303	57	P	V
	*	5785	99.83	-	-	87.45	32.14	10.85	30.61	303	57	A	H
		5851.4	56.82	-62.19	119.01	44.28	32.21	10.98	30.65	303	57	P	V
		5859.2	55.14	-54.48	109.62	42.55	32.24	11	30.65	303	57	P	V
		5899	53.48	-33.92	87.4	40.66	32.4	11.1	30.68	303	57	P	V
		5949	53.4	-14.8	68.2	40.39	32.5	11.22	30.71	303	57	P	V
													V
													V
													V



WIFI Ant. 1	Note	Frequency (MHz)	Level (dBμV/m)	Over Limit (dB)	Limit Line (dBμV/m)	Read Level (dBμV)	Antenna Factor (dB/m)	Path Loss (dB)	Preamp Factor (dB)	Ant Pos (cm)	Table Pos (deg)	Peak Avg. (P/A)	Pol. (H/V)	
802.11n HT20 CH 165 5825MHz	*	5825	102.51	-	-	90.03	32.2	10.91	30.63	251	26	P	H	
	*	5825	93.2	-	-	80.72	32.2	10.91	30.63	251	26	A	H	
		5853.6	57.96	-56.03	113.99	45.41	32.21	10.99	30.65	251	26	P	H	
		5856.8	57.46	-52.84	110.3	44.89	32.23	10.99	30.65	251	26	P	H	
		5875.2	53.84	-51.21	105.05	41.16	32.3	11.04	30.66	251	26	P	H	
		5932.6	53.01	-15.19	68.2	40.06	32.47	11.18	30.7	251	26	P	H	
														H
														H
	*	5825	108.89	-	-	96.41	32.2	10.91	30.63	293	56	P	V	
	*	5825	99.46	-	-	86.98	32.2	10.91	30.63	293	56	A	V	
		5854.4	62.94	-49.23	112.17	50.38	32.22	10.99	30.65	293	56	P	V	
		5856.4	61.74	-48.67	110.41	49.17	32.23	10.99	30.65	293	56	P	V	
		5876.6	60.4	-43.61	104.01	47.71	32.31	11.04	30.66	293	56	P	V	
		5950	53.17	-15.03	68.2	40.15	32.5	11.23	30.71	293	56	P	V	
														V
														V
Remark	1. No other spurious found. 2. All results are PASS against Peak and Average limit line.													



Band 4 5725~5850MHz
WIFI 802.11n HT20 (Harmonic @ 3m)

WIFI Ant. 1	Note	Frequency (MHz)	Level (dBμV/m)	Over Limit (dB)	Limit Line (dBμV/m)	Read Level (dBμV)	Antenna Factor (dB/m)	Path Loss (dB)	Preamp Factor (dB)	Ant Pos (cm)	Table Pos (deg)	Peak Avg. (P/A)	Pol. (H/V)	
802.11n HT20 CH 149 5745MHz		11490	49.33	-24.67	74	55.59	40.48	14.85	61.59	100	0	P	H	
		17235	49.54	-18.66	68.2	48.75	40.94	18.67	58.82	100	0	P	H	
													H	
													H	
			11490	49.41	-24.59	74	55.67	40.48	14.85	61.59	100	0	P	V
			17235	50.44	-17.76	68.2	49.65	40.94	18.67	58.82	100	0	P	V
														V
802.11n HT20 CH 157 5785MHz		11570	49.79	-24.21	74	56.21	40.29	14.91	61.62	100	0	P	H	
		17355	51.58	-16.62	68.2	49.57	41.75	18.79	58.53	100	0	P	H	
													H	
													H	
			11570	49.72	-24.28	74	56.14	40.29	14.91	61.62	100	0	P	V
			17355	51.32	-16.88	68.2	49.31	41.75	18.79	58.53	100	0	P	V
														V
802.11n HT20 CH 165 5825MHz		11650	49.14	-24.86	74	55.96	39.85	14.96	61.63	100	0	P	H	
		17475	51.56	-16.64	68.2	48.43	42.5	18.86	58.23	100	0	P	H	
													H	
													H	
			11650	48.85	-25.15	74	55.67	39.85	14.96	61.63	100	0	P	V
			17475	52.39	-15.81	68.2	49.26	42.5	18.86	58.23	100	0	P	V
														V
Remark	1. No other spurious found.													
	2. All results are PASS against Peak and Average limit line.													



Band 4 5725~5850MHz
WIFI 802.11n HT40 (Band Edge @ 3m)

WIFI Ant. 1	Note	Frequency (MHz)	Level (dBμV/m)	Over Limit (dB)	Limit Line (dBμV/m)	Read Level (dBμV)	Antenna Factor (dB/m)	Path Loss (dB)	Preamp Factor (dB)	Ant Pos (cm)	Table Pos (deg)	Peak Avg. (P/A)	Pol. (H/V)
		5610.2	52.36	-15.84	68.2	40.09	31.88	10.89	30.5	268	27	P	H
		5697.6	55.7	-47.73	103.43	43.39	31.99	10.87	30.55	268	27	P	H
		5713.8	55	-54.07	109.07	42.69	32	10.87	30.56	268	27	P	H
		5721.8	55.5	-59.4	114.9	43.2	32	10.87	30.57	268	27	P	H
	*	5755	99.14	-	-	86.85	32.02	10.86	30.59	268	27	P	H
	*	5755	90.92	-	-	78.63	32.02	10.86	30.59	268	27	A	H
		5855	52.41	-58.39	110.8	39.85	32.22	10.99	30.65	268	27	P	H
		5859.6	52.46	-57.05	109.51	39.87	32.24	11	30.65	268	27	P	H
		5921	52.68	-18.47	71.15	39.78	32.44	11.15	30.69	268	27	P	H
		5929.2	53.14	-15.06	68.2	40.21	32.46	11.17	30.7	268	27	P	H
													H
													H
802.11n													
HT40													
CH 151		5637.6	52.81	-15.39	68.2	40.62	31.82	10.89	30.52	318	57	P	V
5755MHz		5694.8	56.36	-45.01	101.37	44.05	31.98	10.88	30.55	318	57	P	V
		5704.2	58.03	-48.35	106.38	45.72	32	10.87	30.56	318	57	P	V
		5720.6	58.41	-53.76	112.17	46.11	32	10.87	30.57	318	57	P	V
	*	5755	104.17	-	-	91.88	32.02	10.86	30.59	318	57	P	V
	*	5755	95.94	-	-	83.65	32.02	10.86	30.59	318	57	A	V
		5850.2	52.37	-69.37	121.74	39.84	32.2	10.98	30.65	318	57	P	V
		5861.6	52.76	-56.19	108.95	40.15	32.25	11.01	30.65	318	57	P	V
		5890.4	52.79	-40.98	93.77	40.02	32.36	11.08	30.67	318	57	P	V
		5945.8	53.01	-15.19	68.2	40.01	32.49	11.22	30.71	318	57	P	V
													V
													V



WIFI Ant. 1	Note	Frequency (MHz)	Level (dBμV/m)	Over Limit (dB)	Limit Line (dBμV/m)	Read Level (dBμV)	Antenna Factor (dB/m)	Path Loss (dB)	Preamp Factor (dB)	Ant Pos (cm)	Table Pos (deg)	Peak Avg. (P/A)	Pol. (H/V)
		5645.6	53.11	-15.09	68.2	40.93	31.81	10.89	30.52	259	26	P	H
		5672.6	52.62	-32.34	84.96	40.39	31.89	10.88	30.54	259	26	P	H
		5705.4	51.89	-54.82	106.71	39.58	32	10.87	30.56	259	26	P	H
		5724	51.86	-68.06	119.92	39.56	32	10.87	30.57	259	26	P	H
	*	5795	98.29	-	-	85.87	32.18	10.85	30.61	259	26	P	H
	*	5795	90.11	-	-	77.69	32.18	10.85	30.61	259	26	A	H
		5852.6	53.41	-62.86	116.27	40.87	32.21	10.98	30.65	259	26	P	H
		5865.8	54.1	-53.67	107.77	41.48	32.26	11.02	30.66	259	26	P	H
		5888.2	52.64	-42.76	95.4	39.89	32.35	11.07	30.67	259	26	P	H
		5939	53.08	-15.12	68.2	40.1	32.48	11.2	30.7	259	26	P	H
802.11n													H
HT40													H
CH 159		5608.6	52.06	-16.14	68.2	39.78	31.88	10.9	30.5	306	57	P	V
5795MHz		5683.8	52.67	-40.58	93.25	40.39	31.94	10.88	30.54	306	57	P	V
		5713.2	52.96	-55.94	108.9	40.65	32	10.87	30.56	306	57	P	V
		5723.4	52.55	-66	118.55	40.25	32	10.87	30.57	306	57	P	V
	*	5795	103.88	-	-	91.46	32.18	10.85	30.61	306	57	P	V
	*	5795	95.91	-	-	83.49	32.18	10.85	30.61	306	57	A	V
		5852.4	57.97	-58.76	116.73	45.43	32.21	10.98	30.65	306	57	P	V
		5855.6	57.25	-53.38	110.63	44.69	32.22	10.99	30.65	306	57	P	V
		5875.8	54.06	-50.55	104.61	41.38	32.3	11.04	30.66	306	57	P	V
		5949.4	52.89	-15.31	68.2	39.87	32.5	11.23	30.71	306	57	P	V
													V
													V
Remark	1. No other spurious found. 2. All results are PASS against Peak and Average limit line.												



**Band 4 5725~5850MHz
WIFI 802.11n HT40 (Harmonic @ 3m)**

WIFI Ant. 1	Note	Frequency (MHz)	Level (dBμV/m)	Over Limit (dB)	Limit Line (dBμV/m)	Read Level (dBμV)	Antenna Factor (dB/m)	Path Loss (dB)	Preamp Factor (dB)	Ant Pos (cm)	Table Pos (deg)	Peak Avg. (P/A)	Pol. (H/V)
802.11n HT40 CH 151 5755MHz		11510	49.73	-24.27	74	56	40.47	14.86	61.6	100	0	P	H
		17265	50.52	-17.68	68.2	49.51	41.06	18.7	58.75	100	0	P	H
													H
													H
		11510	49.94	-24.06	74	56.21	40.47	14.86	61.6	100	0	P	V
		17265	50.61	-17.59	68.2	49.6	41.06	18.7	58.75	100	0	P	V
													V
													V
802.11n HT40 CH 159 5795MHz		11590	49.58	-24.42	74	56.05	40.23	14.92	61.62	100	0	P	H
		17385	51.98	-16.22	68.2	49.58	42.05	18.8	58.45	100	0	P	H
													H
													H
		11590	49.86	-24.14	74	56.33	40.23	14.92	61.62	100	0	P	V
		17385	51.61	-16.59	68.2	49.21	42.05	18.8	58.45	100	0	P	V
													V
													V
Remark	1. No other spurious found. 2. All results are PASS against Peak and Average limit line.												



Band 4 5725~5850MHz
WIFI 802.11ac VHT80 (Band Edge @ 3m)

WIFI Ant. 1	Note	Frequency (MHz)	Level (dBμV/m)	Over Limit (dB)	Limit Line (dBμV/m)	Read Level (dBμV)	Antenna Factor (dB/m)	Path Loss (dB)	Preamp Factor (dB)	Ant Pos (cm)	Table Pos (deg)	Peak Avg. (P/A)	Pol. (H/V)
		5625.8	53.56	-14.64	68.2	41.33	31.85	10.89	30.51	263	27	P	H
		5695.2	54.7	-46.96	101.66	42.39	31.98	10.88	30.55	263	27	P	H
		5719.4	56.36	-54.27	110.63	44.06	32	10.87	30.57	263	27	P	H
		5723.2	56.21	-61.89	118.1	43.91	32	10.87	30.57	263	27	P	H
	*	5775	95.27	-	-	82.91	32.1	10.86	30.6	263	27	P	H
	*	5775	87.64	-	-	75.28	32.1	10.86	30.6	263	27	A	H
		5854.6	52.88	-58.83	111.71	40.32	32.22	10.99	30.65	263	27	P	H
		5859.8	53.4	-56.05	109.45	40.81	32.24	11	30.65	263	27	P	H
		5876.8	53.23	-50.63	103.86	40.54	32.31	11.04	30.66	263	27	P	H
		5938.6	53.41	-14.79	68.2	40.43	32.48	11.2	30.7	263	27	P	H
802.11ac													H
VHT80													H
CH 155		5641	52.64	-15.56	68.2	40.45	31.82	10.89	30.52	297	56	P	V
5775MHz		5700	56.76	-48.44	105.2	44.44	32	10.87	30.55	297	56	P	V
		5719	58.95	-51.57	110.52	46.65	32	10.87	30.57	297	56	P	V
		5720.6	58.77	-53.4	112.17	46.47	32	10.87	30.57	297	56	P	V
	*	5775	100.36	-	-	88	32.1	10.86	30.6	297	56	P	V
	*	5775	92.74	-	-	80.38	32.1	10.86	30.6	297	56	A	V
		5852.2	55.79	-61.39	117.18	43.25	32.21	10.98	30.65	297	56	P	V
		5856	55.34	-55.18	110.52	42.78	32.22	10.99	30.65	297	56	P	V
		5894.6	53.8	-36.86	90.66	41	32.38	11.09	30.67	297	56	P	V
		5949.8	53.82	-14.38	68.2	40.8	32.5	11.23	30.71	297	56	P	V
													V
													V
Remark	1. No other spurious found. 2. All results are PASS against Peak and Average limit line.												



Band 4 5725~5850MHz

WIFI 802.11ac VHT80 (Harmonic @ 3m)

WIFI Ant. 1	Note	Frequency (MHz)	Level (dBμV/m)	Over Limit (dB)	Limit Line (dBμV/m)	Read Level (dBμV)	Antenna Factor (dB/m)	Path Loss (dB)	Preamp Factor (dB)	Ant Pos (cm)	Table Pos (deg)	Peak Avg. (P/A)	Pol. (H/V)	
802.11ac VHT80 CH 155 5775MHz		11550	49.45	-24.55	74	55.81	40.35	14.9	61.61	100	0	P	H	
		17325	52.01	-16.19	68.2	50.39	41.45	18.77	58.6	100	0	P	H	
													H	
													H	
			11550	49.9	-24.1	74	56.26	40.35	14.9	61.61	100	0	P	V
			17325	52.13	-16.07	68.2	50.51	41.45	18.77	58.6	100	0	P	V
														V
Remark	1. No other spurious found. 2. All results are PASS against Peak and Average limit line.													



Emission below 1GHz
5GHz WIFI 802.11a (LF @ 3m)

WIFI	Note	Frequency	Level	Over	Limit	Read	Antenna	Path	Preamp	Ant	Table	Peak	Pol.	
Ant.				Limit	Line	Level	Factor	Loss	Factor	Pos	Pos	Avg.		
1		(MHz)	(dBμV/m)	(dB)	(dBμV/m)	(dBμV)	(dB/m)	(dB)	(dB)	(cm)	(deg)	(P/A)	(H/V)	
5GHz 802.11a LF		36.79	20.65	-19.35	40	31.45	20.82	0.71	32.33	-	-	P	H	
		102.75	25.96	-17.54	43.5	40.45	16.49	1.31	32.29	-	-	P	H	
		206.54	27.12	-16.38	43.5	42.61	14.89	2	32.38	-	-	P	H	
		297.72	34.76	-11.24	46	45.86	19.06	2.35	32.51	-	-	P	H	
		421.88	25.2	-20.8	46	32.16	22.61	2.77	32.34	-	-	P	H	
		885.54	35.23	-10.77	46	34.37	28.55	4.22	31.91	100	0	P	H	
													H	
													H	
													H	
													H	
													H	
													H	
			37.76	29.41	-10.59	40	40.51	20.51	0.73	32.34	100	0	P	V
			97.9	28.73	-14.77	43.5	43.82	15.91	1.28	32.28	-	-	P	V
			142.52	19.67	-23.83	43.5	33	17.58	1.6	32.51	-	-	P	V
			200.72	21.61	-21.89	43.5	36.95	15.07	1.97	32.38	-	-	P	V
			295.78	27.27	-18.73	46	38.4	19.03	2.35	32.51	-	-	P	V
			882.63	33.28	-12.72	46	32.41	28.56	4.21	31.9	-	-	P	V
														V
														V
													V	
													V	
													V	
													V	
Remark	1. No other spurious found. 2. All results are PASS against limit line.													



Note symbol

*	Fundamental Frequency which can be ignored. However, the level of any unwanted emissions shall not exceed the level of the fundamental frequency.
!	Test result is over limit line.
P/A	Peak or Average
H/V	Horizontal or Vertical



A calculation example for radiated spurious emission is shown as below:

WIFI	Note	Frequency	Level	Over	Limit	Read	Antenna	Path	Preamp	Ant	Table	Peak	Pol.
Ant.				Limit	Line	Level	Factor	Loss	Factor	Pos	Pos	Avg.	
1		(MHz)	(dBμV/m)	(dB)	(dBμV/m)	(dBμV)	(dB/m)	(dB)	(dB)	(cm)	(deg)	(P/A)	(H/V)
802.11b		2390	55.45	-18.55	74	54.51	32.22	4.58	35.86	103	308	P	H
CH 01													
2412MHz		2390	43.54	-10.46	54	42.6	32.22	4.58	35.86	103	308	A	H

1. Path Loss(dB) = Cable loss(dB) + Filter loss(dB) + Attenuator loss(dB)
2. Level(dBμV/m) = Antenna Factor(dB/m) + Path Loss(dB) + Read Level(dBμV) - Preamp Factor(dB)
3. Over Limit(dB) = Level(dBμV/m) – Limit Line(dBμV/m)

For Peak Limit @ 2390MHz:

1. Level(dBμV/m)
= Antenna Factor(dB/m) + Path Loss(dB) + Read Level(dBμV) - Preamp Factor(dB)
= 32.22(dB/m) + 4.58(dB) + 54.51(dBμV) – 35.86 (dB)
= 55.45 (dBμV/m)
2. Over Limit(dB)
= Level(dBμV/m) – Limit Line(dBμV/m)
= 55.45(dBμV/m) – 74(dBμV/m)
= -18.55(dB)

For Average Limit @ 2390MHz:

1. Level(dBμV/m)
= Antenna Factor(dB/m) + Path Loss(dB) + Read Level(dBμV) - Preamp Factor(dB)
= 32.22(dB/m) + 4.58(dB) + 42.6(dBμV) – 35.86 (dB)
= 43.54 (dBμV/m)
2. Over Limit(dB) = Level(dBμV/m) – Limit Line(dBμV/m)
= 43.54(dBμV/m) – 54(dBμV/m)
= -10.46(dB)

Both peak and average measured complies with the limit line, so test result is “PASS”.



Appendix D. Radiated Spurious Emission Plots

Test Engineer :	Leo Lee, Mancy Chou and Bigshow Wang	Temperature :	22.1~23.1°C
		Relative Humidity :	55~60%

Note symbol

-L	Low channel location
-R	High channel location



Band 4 - 5725~5850MHz
WIFI 802.11a (Band Edge @ 3m)

WIFI	Band 4 5725~5850MHz Band Edge @ 3m	
ANT	802.11a CH149 5745MHz	
1	Horizontal	Fundamental
Peak	<p>Site : 03CH15-11Y Condition : PEAK_BE(B4)_16-24 3m 91200_15_1620 HORIZONTAL Detector : Peak Project : 042038</p>	<p>Site : 03CH15-11Y Condition : PEAK(UNIT) 3m 91200_15_1620 HORIZONTAL Detector : Peak Project : 042038</p>

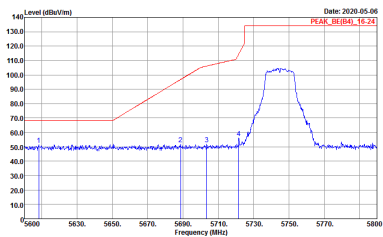
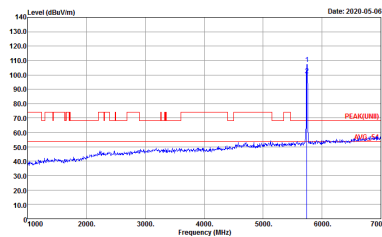

WIFI	Band 4 5725~5850MHz Band Edge @ 3m	
ANT	802.11a CH149 5745MHz	
1	Vertical	Fundamental
Peak	 <p>Date: 2020-05-06 PEAK_BE(B4)_16-24</p> <p>Site : 03CH15-14Y Condition : PEAK_BE(B4)_16-24 3m 91200_15_1620 VERTICAL Detector : RBW:1000.000KHz VBW:3000.000KHz SWT:Auto Project : 042038</p>	 <p>Date: 2020-05-06 PEAK(LINB)</p> <p>Site : 03CH15-14Y Condition : PEAK(LINB) 3m 91200_15_1620 VERTICAL Detector : RBW:1000.000KHz VBW:3000.000KHz SWT:Auto Project : 042038</p>



WIFI	Band 4 5725~5850MHz Band Edge @ 3m	
ANT	802.11a CH157 5785MHz	
1	Horizontal	Fundamental
<p>Peak</p>	<p>Site : 03CH15-HY Condition : PEAK_BE(B4)_16-24 3m 91200_15_1620 HORIZONTAL Detector : Peak Project : 042038</p>	<p>Site : 03CH15-HY Condition : PEAK(LINII) 3m 91200_15_1620 HORIZONTAL Detector : Peak Project : 042038</p>
<p>Peak</p>	<p>Site : 03CH15-HY Condition : PEAK_BE(B4)_16-24 3m 91200_15_1620 HORIZONTAL Detector : Peak Project : 042038</p>	<p>Left blank</p>



WIFI	Band 4 5725~5850MHz Band Edge @ 3m	
ANT	802.11a CH157 5785MHz	
1	Vertical	Fundamental
Peak	<p>Site : 03CH15-HY Condition : PEAK_BE(B4)_16-24 3m 91200_15_1620 VERTICAL Detector : RBW:1000.000KHz VBW:3000.000KHz SWT:Auto Project : Peak Project : -042038</p>	<p>Site : 03CH15-HY Condition : PEAK(LINII) 3m 91200_15_1620 VERTICAL Detector : Peak Project : -042038</p>
	<p>Site : 03CH15-HY Condition : PEAK_BE(B4)_16-24 3m 91200_15_1620 VERTICAL Detector : RBW:1000.000KHz VBW:3000.000KHz SWT:Auto Project : Peak Project : -042038</p>	Left blank

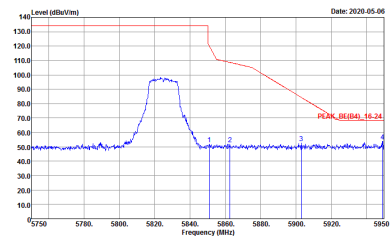
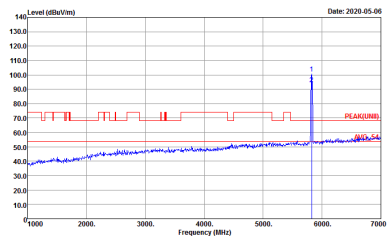

WIFI	Band 4 5725~5850MHz Band Edge @ 3m	
ANT	802.11a CH165 5825MHz	
1	Horizontal	Fundamental
Peak	 <p>Site : 03CH15-11Y Condition : PEAK_BE(B4)_16-24 3m 91200_15_1620 HORIZONTAL RBW:1000.000KHz VBW:3000.000KHz SWT:Auto Detector : Peak Project : 042038</p>	 <p>Site : 03CH15-11Y Condition : PEAK(LINII) 3m 91200_15_1620 HORIZONTAL RBW:1000.000KHz VBW:3000.000KHz SWT:Auto Detector : Peak Project : 042038</p>

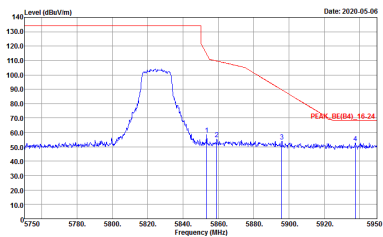
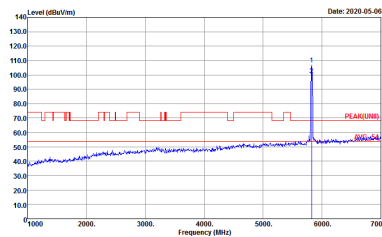

WIFI	Band 4 5725~5850MHz Band Edge @ 3m	
ANT	802.11a CH165 5825MHz	
1	Vertical	Fundamental
Peak	 <p>Site : 03CH15-11Y Condition : PEAK_BE(B4)_16-24 3m 91200_15_1620 VERTICAL RBW:1000.000KHz VBW:3000.000KHz SWT:Auto Detector : Peak Project : -042038</p>	 <p>Site : 03CH15-11Y Condition : PEAK(LINII) 3m 91200_15_1620 VERTICAL RBW:1000.000KHz VBW:3000.000KHz SWT:Auto Detector : Peak Project : -042038</p>



**Band 4 5725~5850MHz
WIFI 802.11n HT20 (Band Edge @ 3m)**

WIFI	Band 4 5725~5850MHz Band Edge @ 3m	
ANT	802.11n HT20 CH149 5745MHz	
1	Horizontal	Fundamental
Peak	<p>Site : 03CH15-HY Condition : PEAK_BE(B4)_16-24 3m 91200_15_1620 HORIZONTAL Detector : Peak Project : 042038</p>	<p>Site : 03CH15-HY Condition : PEAK(UNIT) 3m 91200_15_1620 HORIZONTAL Detector : Peak Project : 042038</p>

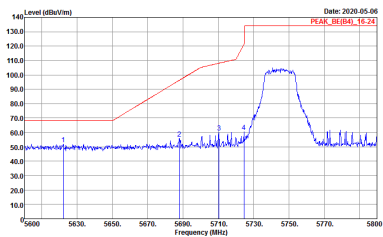
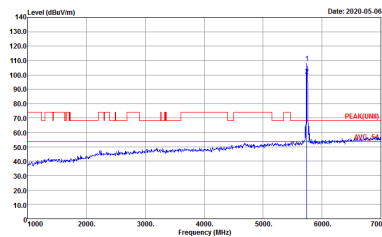

WIFI	Band 4 5725~5850MHz Band Edge @ 3m	
ANT	802.11n HT20 CH149 5745MHz	
1	Vertical	Fundamental
Peak	 <p>Site : 03CH15-11Y Condition : PEAK_BE(B4)_16-24 3m 91200_15_1620 VERTICAL Detector : Peak Project : 042038</p>	 <p>Site : 03CH15-11Y Condition : PEAK(LINII) 3m 91200_15_1620 VERTICAL Detector : Peak Project : 042038</p>



WIFI	Band 4 5725~5850MHz Band Edge @ 3m	
ANT	802.11n HT20 CH157 5785MHz	
1	Horizontal	Fundamental
Peak	<p>Site : 03CH15-HY Condition : PEAK_BE(B4)_16-24 3m 91200_15_1620 HORIZONTAL Detector : Peak Project : 042038</p>	<p>Site : 03CH15-HY Condition : PEAK(LINII) 3m 91200_15_1620 HORIZONTAL Detector : Peak Project : 042038</p>
Peak	<p>Site : 03CH15-HY Condition : PEAK_BE(B4)_16-24 3m 91200_15_1620 HORIZONTAL Detector : Peak Project : 042038</p>	Left blank

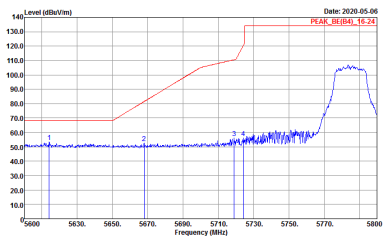
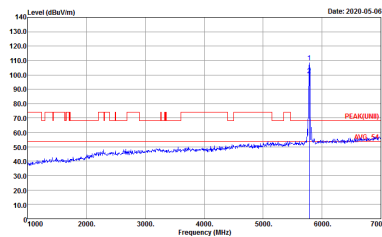
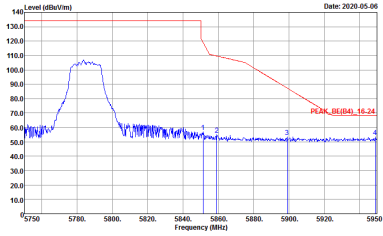

WIFI	Band 4 5725~5850MHz Band Edge @ 3m	
ANT	802.11n HT20 CH157 5785MHz	
1	Vertical	Fundamental
Peak	 <p>Date: 2020-05-06 PEAK_BE(B4)_16-24</p> <p>Site : 03CH15-HY Condition : PEAK_BE(B4)_16-24 3m 91200_15_1620 VERTICAL Detector : RBW:1000.000KHz VBW:3000.000KHz SWT:Auto Project : 042038</p>	 <p>Date: 2020-05-06 PEAK(FUNB)</p> <p>Site : 03CH15-HY Condition : PEAK(FUNB)_16-24 3m 91200_15_1620 VERTICAL Detector : RBW:1000.000KHz VBW:3000.000KHz SWT:Auto Project : 042038</p>
Peak	 <p>Date: 2020-05-06 PEAK_BE(B4)_16-24</p> <p>Site : 03CH15-HY Condition : PEAK_BE(B4)_16-24 3m 91200_15_1620 VERTICAL Detector : RBW:1000.000KHz VBW:3000.000KHz SWT:Auto Project : 042038</p>	Left blank

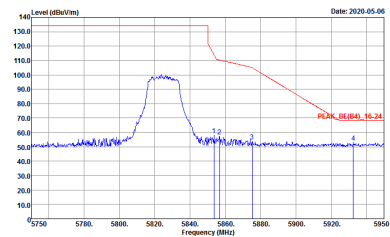
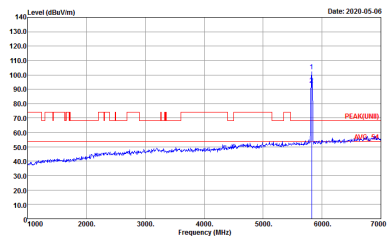

WIFI	Band 4 5725~5850MHz Band Edge @ 3m	
ANT	802.11n HT20 CH165 5825MHz	
1	Horizontal	Fundamental
Peak	 <p>Site : 03CH15-11Y Condition : PEAK_BE(B4)_16-24 3m 91200_15_1620 HORIZONTAL Detector : Peak Project : 042038</p>	 <p>Site : 03CH15-11Y Condition : PEAK(LINII) 3m 91200_15_1620 HORIZONTAL Detector : Peak Project : 042038</p>

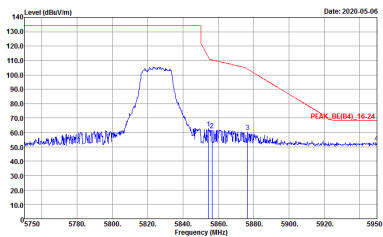
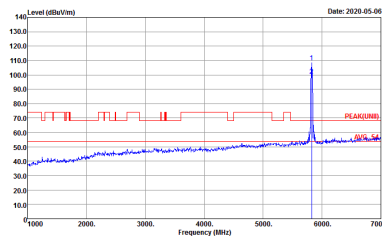

WIFI	Band 4 5725~5850MHz Band Edge @ 3m	
ANT	802.11n HT20 CH165 5825MHz	
1	Vertical	Fundamental
Peak	 <p>Site : 03CH15-11Y Condition : PEAK_BE(B4)_16-24 3m 91200_15_1620 VERTICAL Detector : Peak Project : 042038</p>	 <p>Site : 03CH15-11Y Condition : PEAK(UNII) 3m 91200_15_1620 VERTICAL Detector : Peak Project : 042038</p>



**Band 4 5725~5850MHz
WIFI 802.11n HT40 (Band Edge @ 3m)**

WIFI	Band 4 5725~5850MHz Band Edge @ 3m	
ANT	802.11n HT40 CH151 5755MHz	
1	Horizontal	Fundamental
Peak	<p>Site : 03CH15-HY Condition : PEAK_BE(B4)_16-24 3m 91200_15_1620 HORIZONTAL Detector : Peak Project : 042038</p>	<p>Site : 03CH15-HY Condition : PEAK(UNIT) 3m 91200_15_1620 HORIZONTAL Detector : Peak Project : 042038</p>
Peak	<p>Site : 03CH15-HY Condition : PEAK_BE(B4)_16-24 3m 91200_15_1620 HORIZONTAL Detector : Peak Project : 042038</p>	Left blank

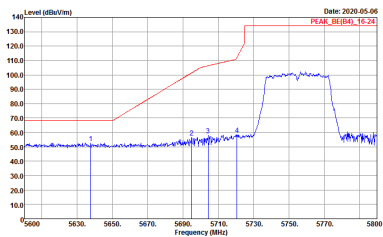
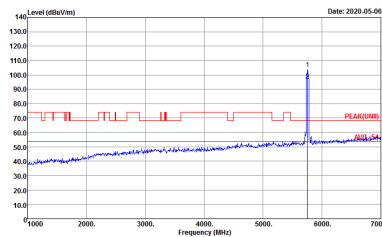
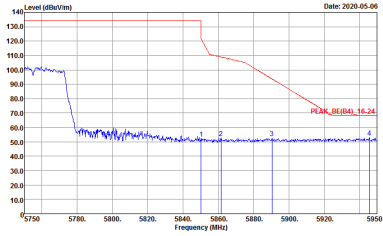

WIFI	Band 4 5725~5850MHz Band Edge @ 3m	
ANT	802.11n HT40 CH151 5755MHz	
1	Vertical	Fundamental
<p>Peak</p>	 <p>Date: 2020-05-06 PEAK_BE(B4)_16-24</p> <p>Site : 03CH15-HY Condition : PEAK_BE(B4)_16-24 3m 91200_15_1620 VERTICAL Detector : RBW:1000.000KHz VBW:3000.000KHz SWT:Auto Project : Peak Project : 042038</p>	 <p>Date: 2020-05-06 PEAK(LINB)</p> <p>Site : 03CH15-HY Condition : PEAK(LINB)_3m 91200_15_1620 VERTICAL Detector : RBW:1000.000KHz VBW:3000.000KHz SWT:Auto Project : Peak Project : 042038</p>
<p>Peak</p>	 <p>Date: 2020-05-06 PEAK_BE(B4)_16-24</p> <p>Site : 03CH15-HY Condition : PEAK_BE(B4)_16-24 3m 91200_15_1620 VERTICAL Detector : RBW:1000.000KHz VBW:3000.000KHz SWT:Auto Project : Peak Project : 042038</p>	<p>Left blank</p>



WIFI	Band 4 5725~5850MHz Band Edge @ 3m	
ANT	802.11n HT40 CH159 5795MHz	
1	Horizontal	Fundamental
Peak	<p>Site : 03CH15-HY Condition : PEAK_BE(B4)_16-24 3m 91200_15_1620 HORIZONTAL Detector : Peak Project : 042038</p>	<p>Site : 03CH15-HY Condition : PEAK(LINII) 3m 91200_15_1620 HORIZONTAL Detector : Peak Project : 042038</p>
Peak	<p>Site : 03CH15-HY Condition : PEAK_BE(B4)_16-24 3m 91200_15_1620 HORIZONTAL Detector : Peak Project : 042038</p>	Left blank



WIFI	Band 4 5725~5850MHz Band Edge @ 3m	
ANT	802.11n HT40 CH159 5795MHz	
1	Vertical	Fundamental
Peak	<p>Site : 03CH15-HY Condition : PEAK_BE(B4)_16-24 3m 91200_15_1620 VERTICAL Detector : Peak Project : 042038</p>	<p>Site : 03CH15-HY Condition : PEAK(LINII) 3m 91200_15_1620 VERTICAL Detector : Peak Project : 042038</p>
Peak	<p>Site : 03CH15-HY Condition : PEAK_BE(B4)_16-24 3m 91200_15_1620 VERTICAL Detector : Peak Project : 042038</p>	Left blank



Band 4 5725~5850MHz
WIFI 802.11ac VHT80 (Band Edge @ 3m)

WIFI	Band 4 5725~5850MHz Band Edge @ 3m	
ANT	802.11ac VHT80 CH155 5775MHz	
1	Horizontal	Fundamental
Peak	<p>Site : 03CH15-HY Condition : PEAK_BE(B4)_16-24 3m 91200_15_1620 HORIZONTAL RBW:1000.000KHz VBW:3000.000KHz SWT:Auto Detector : Peak Project : 042038</p>	<p>Site : 03CH15-HY Condition : PEAK(UNIT) 3m 91200_15_1620 HORIZONTAL RBW:1000.000KHz VBW:3000.000KHz SWT:Auto Detector : Peak Project : 042038</p>
Peak	<p>Site : 03CH15-HY Condition : PEAK_BE(B4)_16-24 3m 91200_15_1620 HORIZONTAL RBW:1000.000KHz VBW:3000.000KHz SWT:Auto Detector : Peak Project : 042038</p>	Left blank

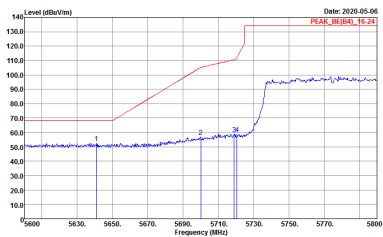
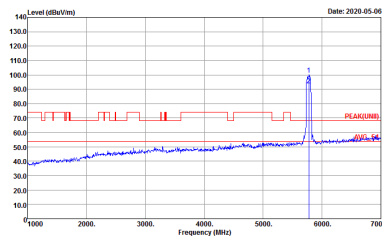
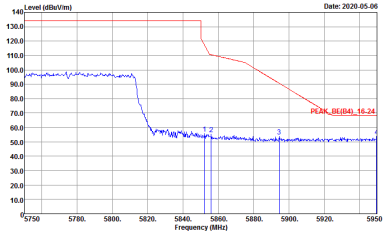

WIFI	Band 4 5725~5850MHz Band Edge @ 3m	
ANT	802.11ac VHT80 CH155 5775MHz	
1	Vertical	Fundamental
<p>Peak</p>	 <p>Site : 03CH15-HY Condition : PEAK_BE(B4)_16-24 3m 91200_15_1620 VERTICAL Detector : Peak Project : 042038</p>	 <p>Site : 03CH15-HY Condition : PEAK(LINII) 3m 91200_15_1620 VERTICAL Detector : Peak Project : 042038</p>
<p>Peak</p>	 <p>Site : 03CH15-HY Condition : PEAK_BE(B4)_16-24 3m 91200_15_1620 VERTICAL Detector : Peak Project : 042038</p>	<p>Left blank</p>

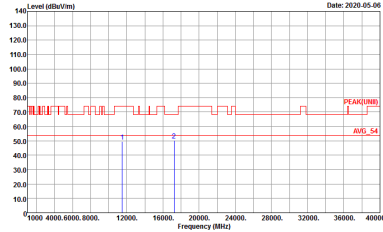
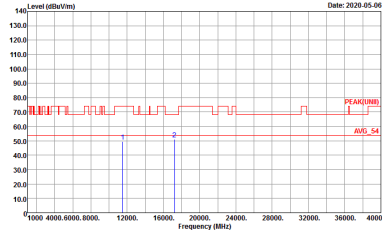

**Band 4 - 5725~5850MHz
WIFI 802.11a (Harmonic @ 3m)**

WIFI	Band 4 5725~5850MHz Harmonic @ 3m	
ANT	802.11a CH149 5745MHz	
1	Horizontal	Vertical
<p>Peak</p> <p>Avg.</p>	 <p>Date: 2020-05-06</p> <p>Site : 03CH15-11Y Condition : PEAK(LINEI) 3m 9120D_15_1620 HORIZONTAL Detector : Peak Project : 042038</p>	 <p>Date: 2020-05-06</p> <p>Site : 03CH15-11Y Condition : PEAK(LINEI) 3m 9120D_15_1620 VERTICAL Detector : Peak Project : 042038</p>



WIFI	Band 4 5725~5850MHz Harmonic @ 3m	
ANT	802.11a CH157 5785MHz	
1	Horizontal	Vertical
Peak Avg.	<p>Site : 03CH15-11Y Condition : PEAK(LINE1) 3m 91200_15_1620 HORIZONTAL Detector : Peak Project : 042038</p>	<p>Site : 03CH15-11Y Condition : PEAK(LINE1) 3m 91200_15_1620 VERTICAL Detector : Peak Project : 042038</p>

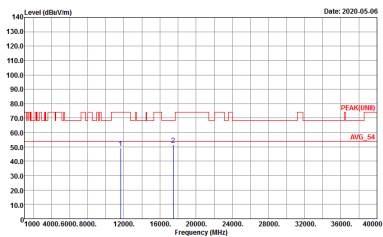
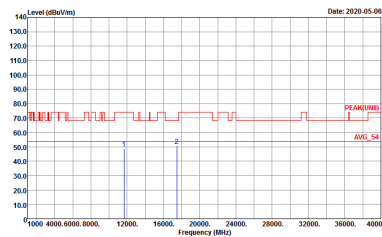

WIFI	Band 4 5725~5850MHz Harmonic @ 3m	
ANT	802.11a CH165 5825MHz	
1	Horizontal	Vertical
<p>Peak</p> <p>Avg.</p>	 <p>Site : 03CH15-11Y Condition : PEAK(LINE1) 3m 9120D_15_1620 HORIZONTAL Detector : Peak Project : 042038</p>	 <p>Site : 03CH15-11Y Condition : PEAK(LINE1) 3m 9120D_15_1620 VERTICAL Detector : Peak Project : 042038</p>



Band 4 5725~5850MHz
WIFI 802.11n HT20 (Harmonic @ 3m)

WIFI	Band 4 5725~5850MHz Harmonic @ 3m	
ANT	802.11n HT20 CH149 5745MHz	
1	Horizontal	Vertical
<p>Peak</p> <p>Avg.</p>	<p>Site : 03CH15-HY Condition : PEAK(UNIT) 3m 91200_15_1620 HORIZONTAL Detector : Peak Project : 042038</p>	<p>Site : 03CH15-HY Condition : PEAK(UNIT) 3m 91200_15_1620 VERTICAL Detector : Peak Project : 042038</p>

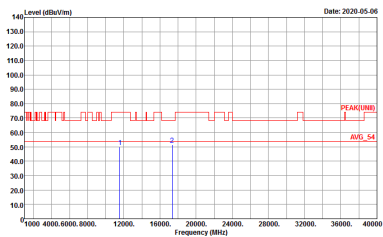
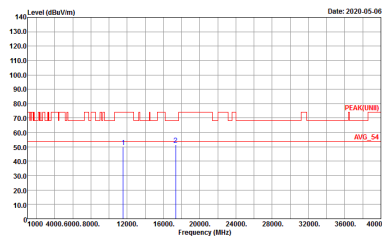

WIFI	Band 4 5725~5850MHz Harmonic @ 3m	
ANT	802.11n HT20 CH157 5785MHz	
1	Horizontal	Vertical
<p>Peak</p> <p>Avg.</p>	 <p>Site : 03CH15-11Y Condition : PEAK(LINE1) 3m 9120D_15_1620 HORIZONTAL Detector : Peak Project : 042038</p>	 <p>Site : 03CH15-11Y Condition : PEAK(LINE1) 3m 9120D_15_1620 VERTICAL Detector : Peak Project : 042038</p>



WIFI	Band 4 5725~5850MHz Harmonic @ 3m	
ANT	802.11n HT20 CH165 5825MHz	
1	Horizontal	Vertical
Peak Avg.	<p>Site : 03CH15-11Y Condition : PEAK(LINE1) 3m 9120D_15_1620 HORIZONTAL Detector : Peak Project : 042038</p>	<p>Site : 03CH15-11Y Condition : PEAK(LINE1) 3m 9120D_15_1620 VERTICAL Detector : Peak Project : 042038</p>



**Band 4 5725~5850MHz
WIFI 802.11n HT40 (Harmonic @ 3m)**

WIFI	Band 4 5725~5850MHz Harmonic @ 3m	
ANT	802.11n HT40 CH151 5755MHz	
1	Horizontal	Vertical
<p>Peak</p> <p>Avg.</p>	<p>Site : 03CH15-HY Condition : PEAK(UNIT) 3m 91200_15_1620 HORIZONTAL Detector : Peak Project : 042038</p>	<p>Site : 03CH15-HY Condition : PEAK(UNIT) 3m 91200_15_1620 VERTICAL Detector : Peak Project : 042038</p>



WIFI	Band 4 5725~5850MHz Harmonic @ 3m	
ANT	802.11n HT40 CH159 5795MHz	
1	Horizontal	Vertical
Peak Avg.	<p>Site : 03CH15-11Y Condition : PEAK(LINE1) 3m 91200_15_1620 HORIZONTAL Detector : Peak Project : 042038</p>	<p>Site : 03CH15-11Y Condition : PEAK(LINE1) 3m 91200_15_1620 VERTICAL Detector : Peak Project : 042038</p>



**Band 4 5725~5850MHz
WIFI 802.11ac VHT80 (Harmonic @ 3m)**

WIFI	Band 4 5725~5850MHz Harmonic @ 3m	
ANT	802.11ac VHT80 CH155 5775MHz	
1	Horizontal	Vertical
<p>Peak</p> <p>Avg.</p>	<p>Site : 03CH15-HY Condition : PEAK(UNIT) 3m 91200_15_1620 HORIZONTAL Detector : Peak Project : 042038</p>	<p>Site : 03CH15-HY Condition : PEAK(UNIT) 3m 91200_15_1620 VERTICAL Detector : Peak Project : 042038</p>

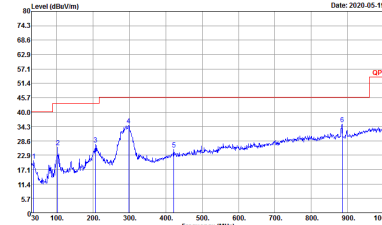
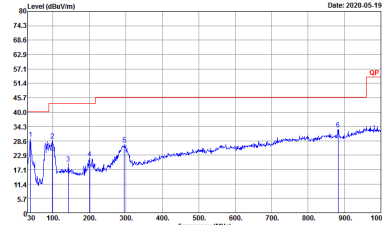

Emission below 1GHz
5GHz WIFI 802.11a (LF)

WIFI	5GHz 5725~5850MHz	
ANT	802.11a LF	
1	Horizontal	Vertical
QP / Peak	 <p>Site : 03CH15-11Y Condition : QP 3m B1LOG_15_41912 HORIZONTAL Detector : Peak Project : 042038 Mode : 11g(n20)_Tx_Ch140-LTE 82-20M HCh 1R80</p>	 <p>Site : 03CH15-11Y Condition : QP 3m B1LOG_15_41912 VERTICAL Detector : Peak Project : 042038 Mode : 11g(n20)_Tx_Ch140-LTE 82-20M HCh 1R80</p>



Appendix E. Duty Cycle Plots

Band	Duty Cycle(%)	T(us)	1/T(kHz)	VBW Setting	Duty Factor(dB)
802.11a	94.72	2065	0.48	1kHz	0.24
5GHz 802.11n HT20	94.62	1935	0.52	1kHz	0.24
5GHz 802.11n HT40	90.80	948	1.05	3kHz	0.42
5GHz 802.11ac VHT80	88.53	733	1.36	3kHz	0.53



802.11a

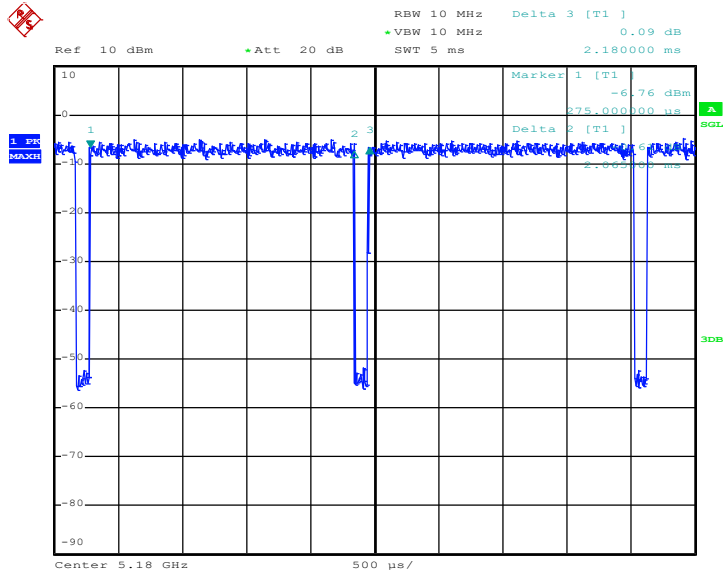

Date: 24.APR.2020 15:46:30

802.11n HT20

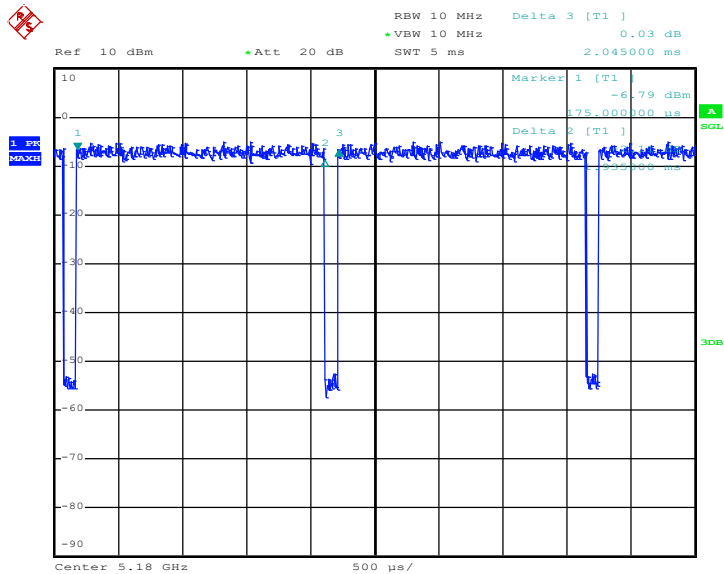

Date: 24.APR.2020 15:48:23



802.11n HT40

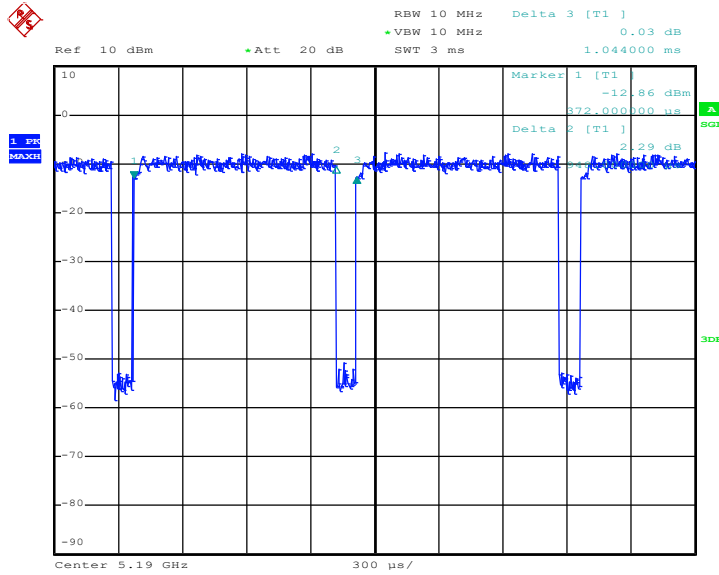

Date: 24.APR.2020 15:52:56

802.11ac VHT80

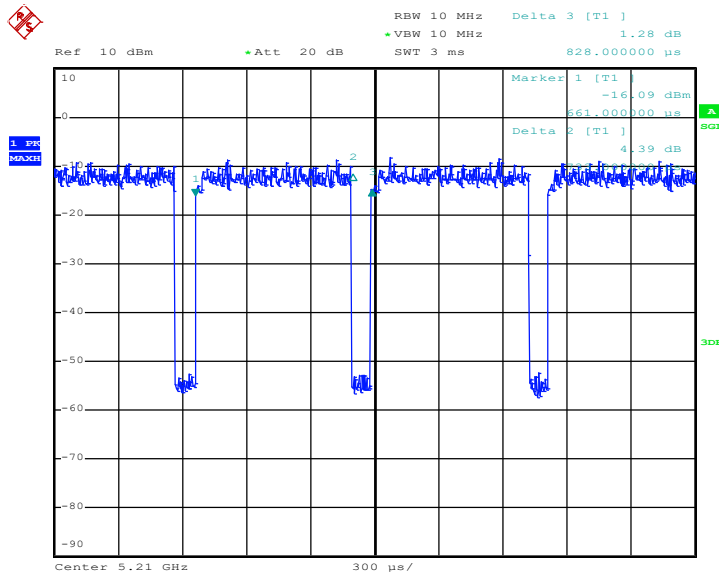

Date: 24.APR.2020 15:57:37