

HEARING AID COMPATIBILITY

Applicant Name:
Panasonic Corporation of North America
Two Riverfront Plaza, 9th Floor
Newark, NJ 07102
United States

Date of Testing:
12/31/2015 - 01/05/2016
Test Site/Location:
PCTEST Lab, Columbia, MD, USA
Test Report Serial No.:
0Y1601060061.ACJ

FCC ID: ACJFZN1A

APPLICANT: PANASONIC CORPORATION OF NORTH AMERICA

Scope of Test: Audio Band Magnetic Testing (T-Coil)
Application Type: Engineering Evaluation (For Reference Only)
HAC Standard: ANSI C63.19-2011
EUT Type: Portable Handset
Model(s): FZ-N1WF
Test Device Serial No.: Pre-Production Sample [S/N: 02081]

C63.19-2011 HAC Category: T4 (SIGNAL TO NOISE CATEGORY)

This wireless portable device has been shown to be hearing-aid compatible under the above rated category, specified in ANSI/IEEE Std. C63.19-2011 and has been tested in accordance with the specified measurement procedures. Test results reported herein relate only to the item(s) tested. Hearing-Aid Compatibility is based on the assumption that all production units will be designed electrically identical to the device tested in this report. North American Bands only.

I attest to the accuracy of data. All measurements reported herein were performed by me or were made under my supervision and are correct to the best of my knowledge and belief. I assume full responsibility for the completeness of these measurements and vouch for the qualifications of all persons taking them.



Randy Ortanez
President







FCC ID: ACJFZN1A		HAC (T-COIL) TEST REPORT		Reviewed by: Quality Manager
Filename: 0Y1601060061.ACJ	Test Dates: 12/31/2015 - 01/05/2016	EUT Type: Portable Handset		Page 1 of 39

TABLE OF CONTENTS

1.	INTRODUCTION	3
2.	TEST SITE LOCATION	4
3.	EUT DESCRIPTION	5
4.	ANSI C63.19-2011 PERFORMANCE CATEGORIES	6
5.	METHOD OF MEASUREMENT	8
6.	SPEECH SIGNAL LEVEL (FOR REFERENCE ONLY)	17
7.	VOIP CLIENT COMPARISONS (FOR REFERENCE ONLY)	19
8.	TEST SUMMARY	20
9.	MEASUREMENT UNCERTAINTY	24
10.	EQUIPMENT LIST	25
11.	CALIBRATION CERTIFICATES	26
12.	CONCLUSION	33
13.	REFERENCES	34
14.	TEST SETUP PHOTOGRAPHS	36

FCC ID: ACJFZN1A		HAC (T-COIL) TEST REPORT		Reviewed by: Quality Manager
Filename: 0Y1601060061.ACJ	Test Dates: 12/31/2015 - 01/05/2016	EUT Type: Portable Handset		Page 2 of 39

1. INTRODUCTION

ANSI Standard C63.19-2011 gives guidance for performing Hearing Aid Compatibility (HAC) testing on any wireless device using any communication protocol. This allows for the benefits of a wider array of devices to be available to individuals with hearing disabilities. These benefits encompass business, social and emergency communications, which increase the value of the wireless network for everyone. An estimated more than 10% of the population in the United States show signs of hearing impairment and of that fraction, almost 80% use hearing aids. Approximately 500 million people worldwide suffer from hearing loss.

Compatibility Tests Involved:

The standard calls for wireless communications devices to be measured for:

- RF Electric-field emissions
- T-coil mode, magnetic-signal strength in the audio band
- T-coil mode, magnetic-signal frequency response through the audio band
- T-coil mode, magnetic-signal and noise articulation index

The hearing aid must be measured for:

- RF immunity in microphone mode
- RF immunity in T-coil mode

In the following tests and results, this report includes the evaluation for a wireless communications device.

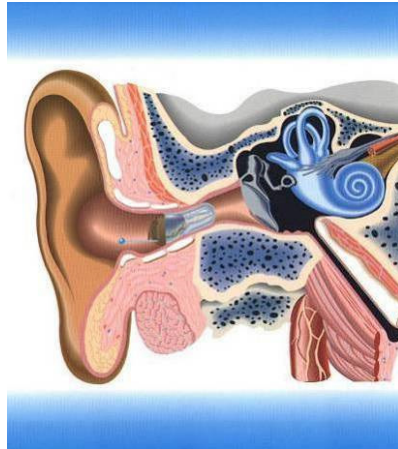



Figure 1-1 Hearing Aid *in-vitu*

FCC ID: ACJFZN1A		HAC (T-COIL) TEST REPORT		Reviewed by: Quality Manager
Filename: 0Y1601060061.ACJ	Test Dates: 12/31/2015 - 01/05/2016	EUT Type: Portable Handset	Page 3 of 39	

© 2016 PCTEST Engineering Laboratory, Inc.

REV 3.1.M
11/27/2015

© 2016 PCTEST Engineering Laboratory, Inc. All rights reserved. Unless otherwise specified, no part of this report may be reproduced or utilized in any part, form or by any means, electronic or mechanical, including photocopying and microfilm, without permission in writing from PCTEST Engineering Laboratory, Inc. If you have any questions about this international copyright or have an enquiry about obtaining additional rights to this report or assembly of contents thereof, please contact INFO@PCTESTLAB.COM.

2. TEST SITE LOCATION

I. Introduction

The map at the right shows the location of the PCTEST LABORATORY in Columbia, Maryland. It is in proximity to the FCC Laboratory, the Baltimore-Washington International (BWI) airport, the city of Baltimore and Washington, DC (See Figure 2-1).

These measurement tests were conducted at the PCTEST Engineering Laboratory, Inc. facility in Stonewood Business Center, Guilford Industrial Park, Columbia, Maryland. The site address is 7185 Oakland Mills Road, Columbia, MD 21046. The test site is one of the highest points in the Columbia area with an elevation of 390 feet above mean sea level. The site coordinates are 39° 10' 24" N latitude and 76° 49' 50" W longitude. The facility is 0.4 miles North of the FCC laboratory, and the ambient signal and ambient signal strength are approximately equal to those of the FCC laboratory.

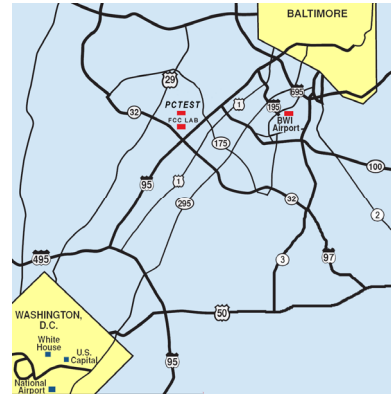



Figure 2-1
Map of the Greater Baltimore and Metropolitan Washington, D.C. area

FCC ID: ACJFZN1A		HAC (T-COIL) TEST REPORT		Reviewed by: Quality Manager
Filename: 0Y1601060061.ACJ	Test Dates: 12/31/2015 - 01/05/2016	EUT Type: Portable Handset	Page 4 of 39	

3. EUT DESCRIPTION



FCC ID: ACJFZN1A
 Applicant: Panasonic Corporation of North America
 Two Riverfront Plaza, 9th Floor
 Newark, NJ 07102
 United States

Model(s): FZ-N1WF
 Serial Number: 02081
 HW Version: N/A
 SW Version: 3077_DCMA_0.11
 Antenna: Internal Antenna
 HAC Test Configurations: 2.4 GHz WLAN, 1, 6, 11, BT Off
 5 GHz WLAN, 36, 48, 165, BT Off

EUT Type: Portable Handset

Air-Interface	Band (MHz)	Type Transport	HAC Tested	Simultaneous But Not Tested	Voice over Digital Transport OTT Capability	WIFI Low Power	Additional GSM Power Reduction
WIFI	2450	VD	Yes	No	Yes	N/A	N/A
	5200						
	5300						
	5500						
	5800						
BT	2450	DT	No	No	N/A	N/A	N/A
Type Transport: VD = CMRS and Data Transport DT = Digital Data - Not intended for CMRS Service							

Table 3-1: ACJFZN1A HAC Air Interfaces

FCC ID: ACJFZN1A	PCTEST ENGINEERING LABORATORY, INC.	HAC (T-COIL) TEST REPORT		Reviewed by: Quality Manager
Filename: 0Y1601060061.ACJ	Test Dates: 12/31/2015 - 01/05/2016	EUT Type: Portable Handset		Page 5 of 39

4. ANSI C63.19-2011 PERFORMANCE CATEGORIES

I. MAGNETIC COUPLING

Axial and Radial Field Intensity

All orientations of the magnetic field, in the axial and radial position along the measurement plane shall be ≥ -18 dB(A/m) at 1 kHz in a 1/3 octave band filter per §8.3.1.

Frequency Response

The frequency response of the axial component of the magnetic field shall follow the response curve specified in EIA RS-504-1983, over the frequency range 300 Hz – 3000 Hz per §8.3.2.

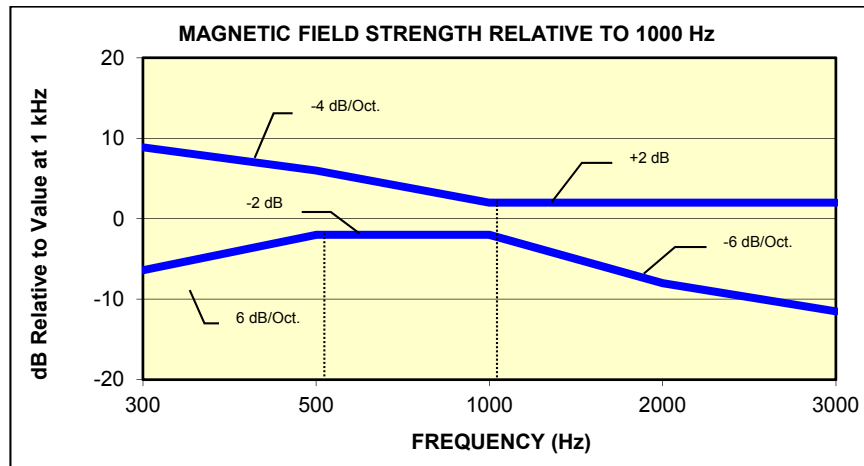

Figure 4-1
Magnetic field frequency response for Wireless Devices with an axial field ≤ -15 dB(A/m) at 1 kHz

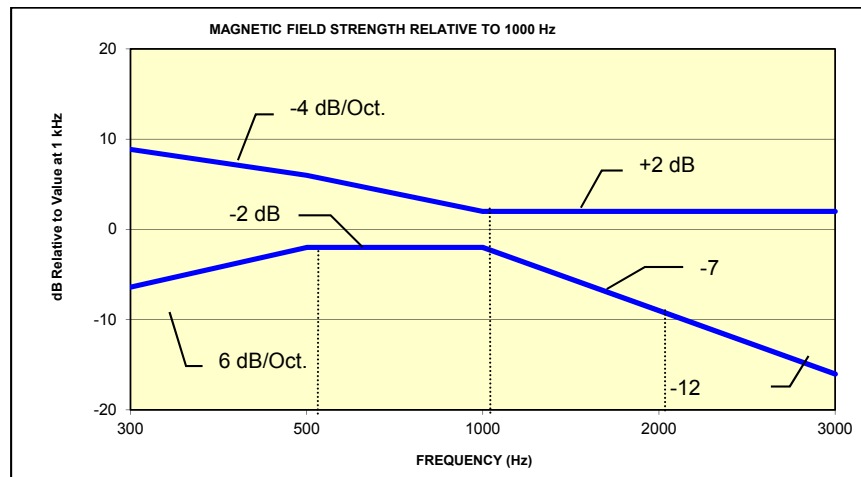



Figure 4-2
Magnetic Field frequency response for wireless devices with an axial field that exceeds -15 dB(A/m) at 1 kHz

FCC ID: ACJFZN1A	 PCTEST ENGINEERING LABORATORY, INC.	HAC (T-COIL) TEST REPORT	 Panasonic	Reviewed by: Quality Manager
Filename: 0Y1601060061.ACJ	Test Dates: 12/31/2015 - 01/05/2016	EUT Type: Portable Handset		Page 6 of 39



Signal Quality

The table below provides the signal quality requirement for the intended audio magnetic signal from a wireless device. Only the RF immunity of the hearing aid is measured in T-coil mode. It is assumed that a hearing aid can have no immunity to an interference signal in the audio band, which is the intended reception band for this mode. The only criterion that can be measured is the RF immunity in T-coil mode. This is measured using the same procedure as the audio coupling mode at the same levels.

The signal quality of the axial and radial components of the magnetic field was used to determine the T-coil mode category.

Category	Telephone RF Parameters
	Wireless Device Signal Quality [(Signal + Noise)-to-noise ratio in dB]
T1	0 to 10 dB
T2	10 to 20 dB
T3	20 to 30 dB
T4	> 30 dB

Table 4-1
Magnetic Coupling Parameters

FCC ID: ACJFZN1A	 PCTEST ENGINEERING LABORATORY, INC.	HAC (T-COIL) TEST REPORT	 Panasonic	Reviewed by: Quality Manager
Filename: 0Y1601060061.ACJ	Test Dates: 12/31/2015 - 01/05/2016	EUT Type: Portable Handset		Page 7 of 39

5. METHOD OF MEASUREMENT

I. Test Setup

The equipment was connected as shown in an acoustic/RF hemi-anechoic chamber:

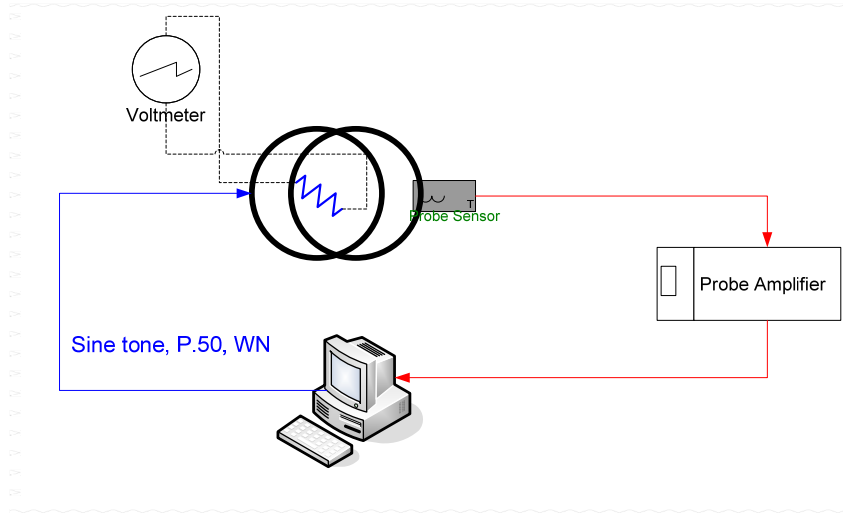

Figure 5-1
Validation Setup with Helmholtz Coil

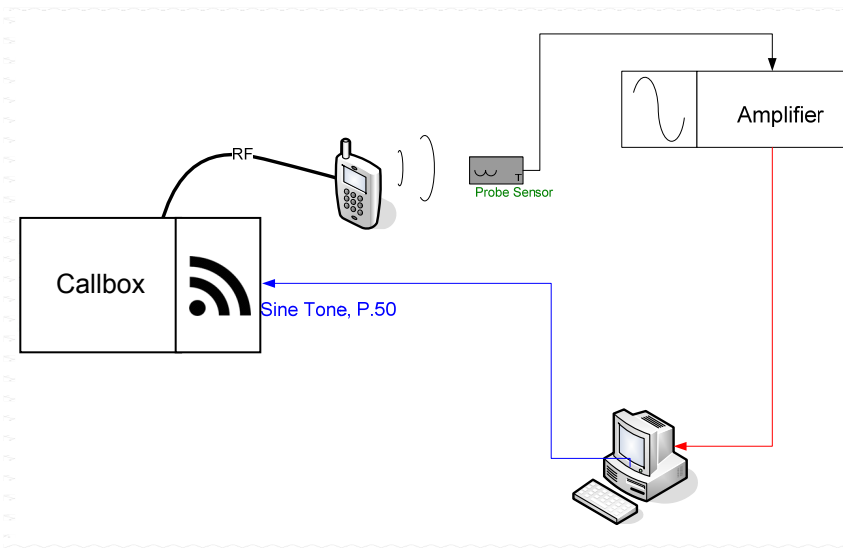



Figure 5-2
T-Coil Test Setup

FCC ID: ACJFZN1A	 PCTEST ENGINEERING LABORATORY, INC.	HAC (T-COIL) TEST REPORT	 Panasonic	Reviewed by: Quality Manager
Filename: 0Y1601060061.ACJ	Test Dates: 12/31/2015 - 01/05/2016	EUT Type: Portable Handset		Page 8 of 39

© 2016 PCTEST Engineering Laboratory, Inc.

REV 3.1.M
11/27/2015

© 2016 PCTEST Engineering Laboratory, Inc. All rights reserved. Unless otherwise specified, no part of this report may be reproduced or utilized in any part, form or by any means, electronic or mechanical, including photocopying and microfilm, without permission in writing from PCTEST Engineering Laboratory, Inc. If you have any questions about this international copyright or have an enquiry about obtaining additional rights to this report or assembly of contents thereof, please contact INFO@PCTESTLAB.COM.

II. Scanning Mechanism

Manufacturer: TEM
 Accuracy: ± 0.83 cm/meter
 Minimum Step Size: 0.1 mm
 Maximum speed: 6.1 cm/sec
 Line Voltage: 115 VAC
 Line Frequency: 60 Hz
 Material Composite: Delrin (Acetal)
 Data Control: Parallel Port
 Dynamic Range (X-Y-Z): 45 x 31.75 x 47 cm
 Dimensions: 36" x 25" x 38"
 Operating Area: 36" x 49" x 55"
 Reflections: < -20 dB (in anechoic chamber)

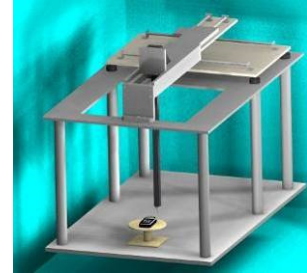

Figure 5-3
RF Near-Field Scanner

III. ITU-T P.50 Artificial Voice

Manufacturer: ITU-T
 Active Frequency Range: 100 Hz – 8 kHz
 Stimulus Type: Male and Female, no spaces
 Single Sample Duration: 20.96 seconds
 Activity Level: 100%



Figure 5-4
Spectral Characteristic of full P.50

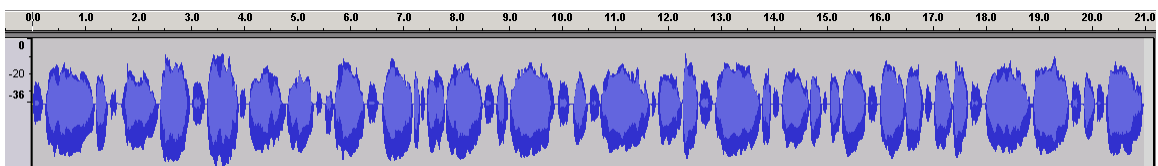

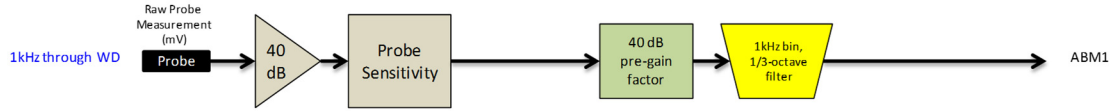

Figure 5-5
Temporal Characteristic of full P.50

FCC ID: ACJFZN1A		HAC (T-COIL) TEST REPORT		Reviewed by: Quality Manager
Filename: 0Y1601060061.ACJ	Test Dates: 12/31/2015 - 01/05/2016	EUT Type: Portable Handset		Page 9 of 39

ABM1 Measurement Block Diagram:



ABM2 Measurement Block Diagram:

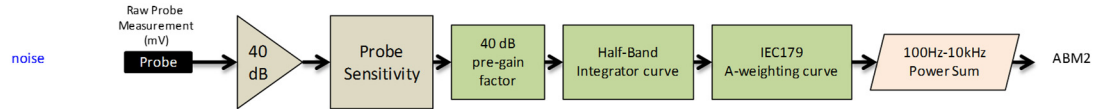

Figure 5-6 Magnetic Measurement Processing Steps

IV. Test Procedure

1. Ambient Noise Check per C63.19 §7.3.1
 - a. Ambient interference was monitored using a Real-Time Analyzer between 100-10,000 Hz with 1/3 octave filtering.
 - b. “A-weighting” and Half-Band Integration was applied to the measurements.
 - c. Since this measurement was measured in the same method as ABM2 measurements, this level was verified to be more than 10 dB below the lowest measurement signal (which is the highest ABM2 measurement for a T4 WD). Therefore the maximum noise level for a T4 WD with an ABM1 = -18 dBA/m is:

$$-18 - 30 - 10 = -58 \text{ dBA/m}$$

2. Measurement System Validation(See Figure 5-1)

- a. The measurement system including the probe, pre-amplifier and acquisition system were validated as an entire system to ensure the reliability of test measurements.
- b. ABM1 Validation
 The magnetic field at the center of the Helmholtz coil is given by the equation (per C63.19 Annex D.10.1):



$$H_c = \frac{NI}{r\sqrt{1.25^3}} = \frac{N\left(\frac{V}{R}\right)}{r\sqrt{1.25^3}}$$

Where H_c = magnetic field strength in amperes per meter
 N = number of turns per coil

For the Helmholtz Coil, $N=20$; $r=0.08\text{m}$; $R=10.2\Omega$ and using $V=18\text{mV}$:

$$H_c = \frac{20 \cdot \left(\frac{0.018}{10.2}\right)}{0.08 \cdot \sqrt{1.25^3}} = 0.316 \text{ A/m} \approx -10 \text{ dB(A/m)}$$

Therefore a pure tone of 1kHz was applied into the coils such that 18mV was observed across the resistor. The voltmeter used for measurement was verified to be capable of measurements in the audio band range. This theoretically generates an expected field of -10 dB(A/m) in the center of the Helmholtz coil which was used to validate the probe measurement at -10dB(A/m). This was verified to be within ± 0.5 dB of the -10dB(A/m) value (see Page 23).

FCC ID: ACJFZN1A		HAC (T-COIL) TEST REPORT		Reviewed by: Quality Manager
Filename: 0Y1601060061.ACJ	Test Dates: 12/31/2015 - 01/05/2016	EUT Type: Portable Handset		Page 10 of 39

c. Frequency Response Validation

The frequency response through the Helmholtz Coil was verified to be within 0.5 dB relative to 1kHz, between 300 – 3000 Hz using the P.50 signal as shown below:

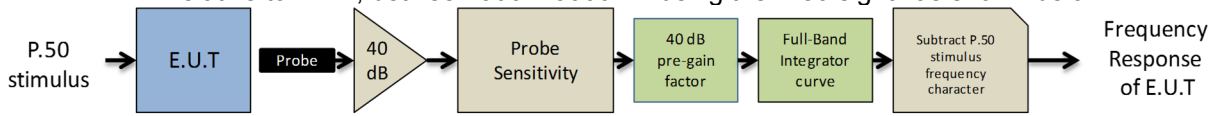



Figure 5-7 Frequency Response Validation

d. ABM2 Measurement Validation

WD noise measurements are filtered with A-weighting and Half-Band Integration over a frequency range of 100Hz – 10kHz to process ABM2 measurements. Below is the verification of the system processing A-weighting and Half-Band integration between system input to output within 0.5 dB of the theoretical result:

Table 5-1
ABM2 Frequency Response Validation

f (Hz)	HBI, A - Measured (dB re 1kHz)	HBI, A - Theoretical (dB re 1kHz)	dB Var.
100	-16.180	-16.170	-0.010
125	-13.257	-13.250	-0.007
160	-10.347	-10.340	-0.007
200	-8.017	-8.010	-0.007
250	-5.925	-5.920	-0.005
315	-4.045	-4.040	-0.005
400	-2.405	-2.400	-0.005
500	-1.212	-1.210	-0.002
630	-0.349	-0.350	0.001
800	0.071	0.070	0.001
1000	0.000	0.000	0.000
1250	-0.503	-0.500	-0.003
1600	-1.513	-1.510	-0.003
2000	-2.778	-2.780	0.002
2500	-4.316	-4.320	0.004
3150	-6.166	-6.170	0.004
4000	-8.322	-8.330	0.008
5000	-10.573	-10.590	0.017
6300	-13.178	-13.200	0.022
8000	-16.241	-16.270	0.029
10000	-19.495	-19.520	0.025

FCC ID: ACJFZN1A		HAC (T-COIL) TEST REPORT		Reviewed by: Quality Manager
Filename: 0Y1601060061.ACJ	Test Dates: 12/31/2015 - 01/05/2016	EUT Type: Portable Handset		Page 11 of 39

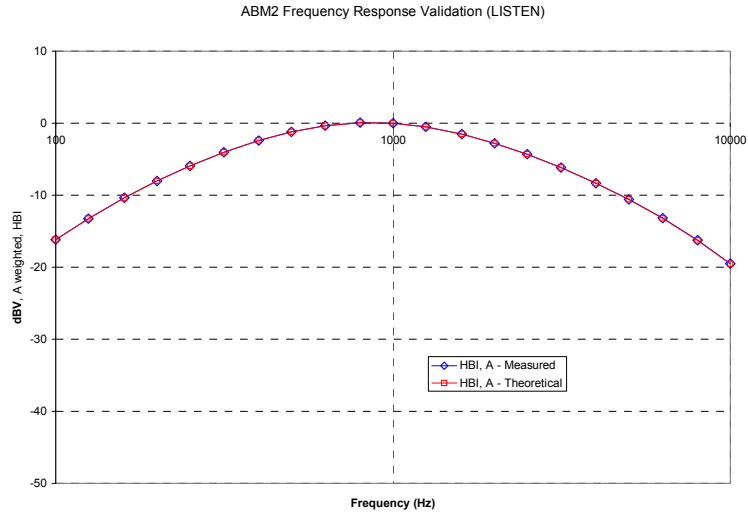

Figure 5-8
ABM2 Frequency Response Validation

The ABM2 result is a power sum from 100Hz to 10kHz with half-band integration and A-weighting. To verify the power sum measurement, a power sum over the full band was measured and verified to track with the source level (See Figure 5-9). Therefore the setup in this step was used to verify the power sum post-processing for ABM2 measurements. See below block diagram:

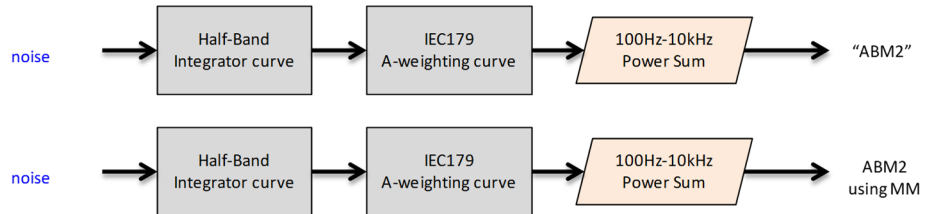



Figure 5-9
ABM2 Validation Block Diagram

The power summed output results for a known input were compared to the multi-meter results to verify any deviation in the post-processing implemented with the power-sum.

Table 5-2
ABM2 Power Sum Validation

WN Input (dBV)	Power Sum (dBV)	Multimeter-Full (dBV)	Dev (dB)
-60	-60.36	-60.2	0.16
-50	-50.19	-50.13	0.06
-40	-40.14	-40.03	0.11
-30	-30.13	-30.01	0.12
-20	-20.12	-20	0.12
-10	-10.14	-10	0.14

FCC ID: ACJFZN1A		HAC (T-COIL) TEST REPORT		Reviewed by: Quality Manager
Filename: 0Y1601060061.ACJ	Test Dates: 12/31/2015 - 01/05/2016	EUT Type: Portable Handset		Page 12 of 39

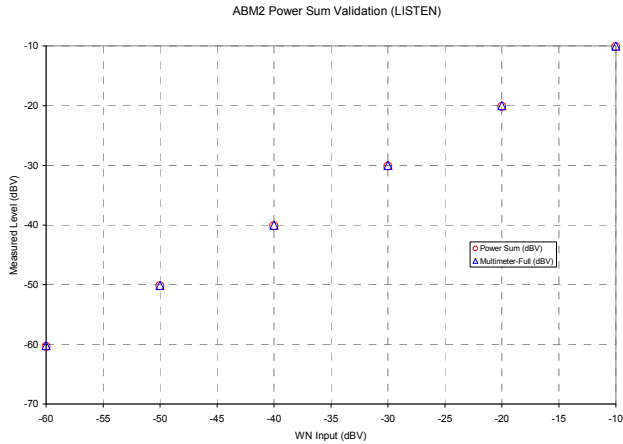

Figure 5-10
ABM2 Power Sum Validation

3. Measurement Test Setup

a. Fine scan above the WD (TEM)

- i. A multitone signal was applied to the handset such that the phone acoustic output was stable within 1dB over the probe settling time and with the acoustic output level at the C63.19 specified levels (below). The measurement step size was in 2 mm increments at a distance of 10 mm between the surface of the wireless device as shown below:

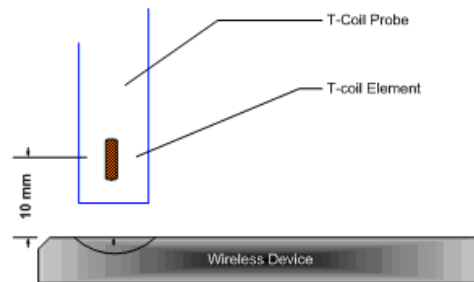

Figure 5-11
Measurement Distance

- ii. After scanning, the planar field maximum point was determined. The position of the probe was moved to this location to setup the test using the SoundCheck system.
 - iii. These steps were repeated for all T-coil orientations (axial and radial) per Figure 5-14 after a T-coil orientation was fully measured with the SoundCheck system.
- b. Speech Signal Setup to Base Station Simulator
- i. See Section 6 for more information regarding audio level settings for WLAN testing.
- c. Real-Time Analyzer (RTA)
- i. The Real-Time Analyzer was configured to analyze measurements using 1/3 Octave band weighted filtering.

FCC ID: ACJFZN1A		HAC (T-COIL) TEST REPORT		Reviewed by: Quality Manager
Filename: 0Y1601060061.ACJ	Test Dates: 12/31/2015 - 01/05/2016	EUT Type: Portable Handset		Page 13 of 39

- d. WD Radio Configuration Selection
 - i. The device was chosen to be tested in the worst-case SNNR condition under the representative VoIP clients. See Section 7 for more information regarding radio and device configuration.
- 4. Signal Quality Data Analysis
 - a. Narrow-band Magnetic Intensity
 - i. The standard specifies a 1kHz 1/3 octave band minimum field intensity for a sine tone. The ABM1 measurements were evaluated at 1kHz with 1/3 octave band filtering over an averaged period of 10 seconds.
 - b. Frequency Response
 - i. The appropriate frequency response curve was measured to curves in Figure 4-1 or Figure 4-2 between 300 – 3000 Hz using digital linear averaging (limit lines chosen according to measurement found in step 4a). A linear average over 3x the length of the artificial voice signal (3x sampling) was performed. A 10 second delay was configured in the measurement process of the stimulus to ensure handset vocoder latency effects and echo cancellation devices (if any) were appropriately stabilized during measurements.
 - ii. The appropriate post-processing was applied according to the system processing chain illustrated in Figure 5-7. All R10 frequencies were plotted with respect to 0dB at 1kHz value and aligned with respect to the EIA-504 mask.
 - iii. The margin is represented by the closest measured data point on the curve to the EIA-504 limit lines, in dB.
 - c. Signal Quality Index
 - i. Ensuring the WD was at maximum RF power, maximum volume, backlight on, display on, maximum contrast setting, keypad lights on (when possible) with no audio signal through the vocoder, the WD was measured over at least 100 Hz – 10,000 Hz, maximized over 5 seconds with a 50ms sample time for the ABM2 measurement (5 second time period is used in noise measurements under standards such as IEEE 269, etc.).
 - ii. After applying half-band integration and A-weighting to the result, a power sum was applied over each 1/3 octave bandwidth frequency for an ABM2 value.
 - iii. This result was subtracted from the ABM1 result in step a, to obtain the Signal Quality.

V. Test Setup

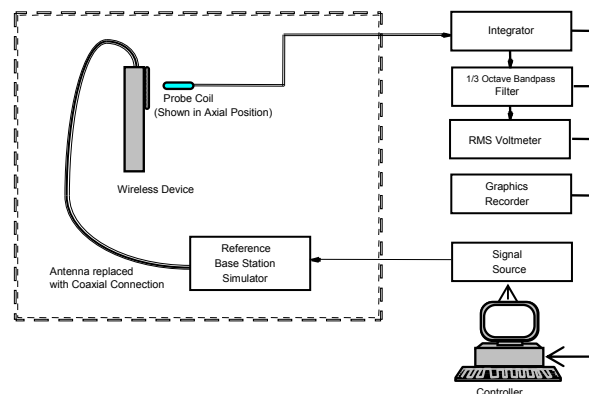

Figure 5-12
Audio Magnetic Field Test Setup

FCC ID: ACJFZN1A		HAC (T-COIL) TEST REPORT		Reviewed by: Quality Manager
Filename: OY1601060061.ACJ	Test Dates: 12/31/2015 - 01/05/2016	EUT Type: Portable Handset		Page 14 of 39

VI. Deviation from C63.19 Test Procedure

Non-conducted RF connection due to inaccessible RF ports.

VII. Air Interface Technologies Tested

This report pertains only to WLAN testing. For other modes, please refer to the appropriate reports.

VIII. RF Emission Effect on T-coil Measurements

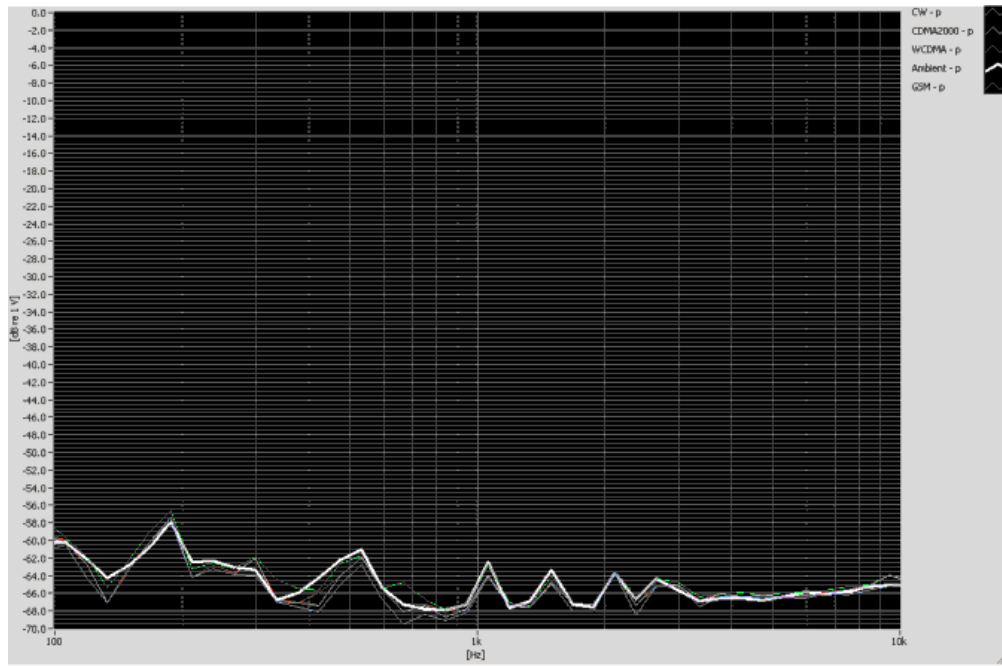



Figure 5-13

High power RF Emissions Effect with HAC Dipole on the T-coil Probe System 10mm between dipole maximum and magnetic probe

FCC ID: ACJFZN1A		HAC (T-COIL) TEST REPORT		Reviewed by: Quality Manager
Filename: 0Y1601060061.ACJ	Test Dates: 12/31/2015 - 01/05/2016	EUT Type: Portable Handset		Page 15 of 39

© 2016 PCTEST Engineering Laboratory, Inc.

REV 3.1.M

11/27/2015

© 2016 PCTEST Engineering Laboratory, Inc. All rights reserved. Unless otherwise specified, no part of this report may be reproduced or utilized in any part, form or by any means, electronic or mechanical, including photocopying and microfilm, without permission in writing from PCTEST Engineering Laboratory, Inc. If you have any questions about this international copyright or have an enquiry about obtaining additional rights to this report or assembly of contents thereof, please contact INFO@PCTESTLAB.COM.

IX. Test Flow

The flow diagram below was followed (From C63.19):

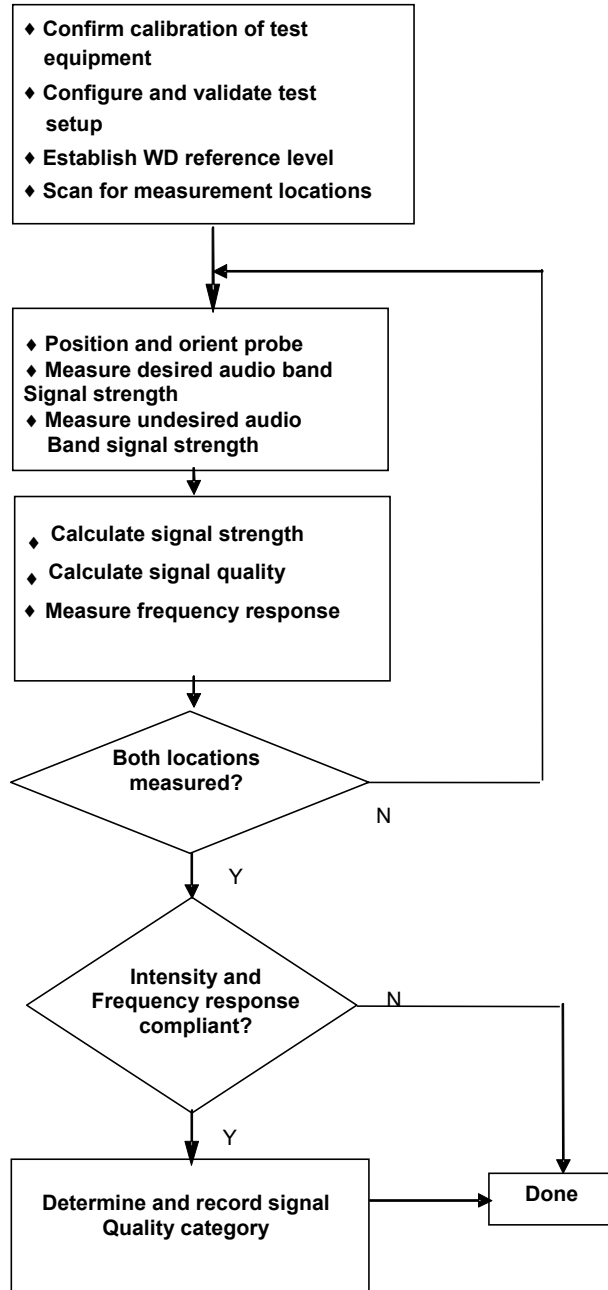



Figure 5-14
C63.19 T-Coil Signal Test Process

FCC ID: ACJFZN1A	 PCTEST ENGINEERING LABORATORY, INC.	HAC (T-COIL) TEST REPORT	 Panasonic	Reviewed by: Quality Manager
Filename: 0Y1601060061.ACJ	Test Dates: 12/31/2015 - 01/05/2016	EUT Type: Portable Handset		Page 16 of 39

6. SPEECH SIGNAL LEVEL (FOR REFERENCE ONLY)

Per ANSI C63.19-2011 §7.4.2.1, when the speech stimulus output level (to be input to the DUT) for a given transmission protocol is not defined, the normal speech level, as defined in that protocol's specifications, should be used for testing. However, for the modes considered in this report, there are no supported CMRS speech modes. Therefore, an investigation was performed to determine the level to be used for the speech stimulus output. The goal of this investigation was to identify an output level of the speech stimulus which, when combined with the other parameters of the signal path, results in an acceptable Receiving Loudness Rating (RLR). This is consistent with the approach outlined in C63.19 Footnote 50 (p.46) for selecting the appropriate speech level for GSM and CDMA.

The following procedure was used to determine an appropriate speech signal level for conducting the testing of this device. Configurations which lead to a passing RLR value are considered to have an acceptable nominal speech input level. According to ITU-T Recommendation P.310 §5.2.2, the nominal value of RLR is +2dB with a tolerance of ±3dB. ITU-T P.310 describes the full method for calculating RLR. The standard used in each step of the following procedure is stated within that step.

1. Using a Head and Torso Simulator (HATS), the sound pressure, P_d , caused by the DUT at the DRP (drum reference point) is measured for a particular speech stimulus level (E_j) per ITU-T P.64 §9. P_d is measured at frequencies 4-17 of the standard 1/3 octave frequencies.
2. The measured sound pressures (P_d) must be corrected using the DRP-ERP transfer function given in Table 2-a of ITU-T P.57. The resulting sound pressure values are labeled P_e (sound pressure at the ear reference point, ERP)
3. The receiving sensitivity at the different frequencies is then calculated by using the E_j and the P_e from Steps 1 and 2 of this procedure in the first equation of ITU-T P.64 §9:

$$S_i = 20 \log_{10} \frac{P_{ei}}{\frac{1}{2} E_j}$$

Where P_{ei} is the P_e at frequency, i ; S_i is the sensitivity at frequency, i ; and the result is in dB[Pa/V].

4. The calculated sensitivities are then used in the equation to calculate the RLR. Equation 5-1 of ITU-T P.79 gives the general loudness rating equation:



$$LR = -\frac{10}{m} \log_{10} \sum_{i=a}^b 10^{0.1 * m(S_i - W_i)}$$

This form has two parameters in addition to the sensitivities that must be known to perform the calculation. These parameters are m and W_i . For all RLR calculations, m is taken to be 0.175 (according to ITU-T P.79 §6) and W_i is specific to the frequency, i , under consideration (it is important to note that there are different W_i values depending on which loudness rating is being calculated [i.e. receiving, sending, etc.] and care should be taken to use the correct values).

Equation A-23c of the same standard (ITU-T P.79) gives the same equation in a simplified form:

$$RLR = -57.1 \log_{10} \sum_i 10^{\left(\frac{1}{57.1}\right)(S_i - W_i)}$$

5. The calculated RLR result (for the specific mode and original input level, E_j) is then compared to the limits. If the RLR is within the acceptable range (-1dB to +5dB), the configuration used (DUT volume setting, speech output level, etc.) is recorded and used for T-coil testing. A summary of the results of investigation for this device can be found on the following page.

FCC ID: ACJFZN1A		HAC (T-COIL) TEST REPORT		Reviewed by: Quality Manager
Filename: 0Y1601060061.ACJ	Test Dates: 12/31/2015 - 01/05/2016	EUT Type: Portable Handset	Page 17 of 39	

I. Summary of Results



The below table of results shows the system and device settings that produced acceptable nominal listening levels (i.e. RLR) for the T-coil testing.

Mode	DUT Volume	Audio Input Level (RMS, in mV)	RLR (in dB)	Verdict
WLAN	Maximum	120mV	2.14	PASS

Table 6-1
Results of RLR Test by Transmission Mode

II. Conclusion

The device achieved compliant RLR test results for all transmission protocols with a test system output level setting of 120mV. Additionally, the device volume was set to maximum for passing RLR results, and this was established for the duration of the T-coil testing. All other configurable parameters were maintained in order to conduct all T-coil testing.

FCC ID: ACJFZN1A		HAC (T-COIL) TEST REPORT		Reviewed by: Quality Manager
Filename: 0Y1601060061.ACJ	Test Dates: 12/31/2015 - 01/05/2016	EUT Type: Portable Handset		Page 18 of 39

7. VOIP CLIENT COMPARISONS (FOR REFERENCE ONLY)

All manufacturer-installed VoIP clients were tested using the device. The client resulting in the worst case SNNR measurement was chosen from the tested clients, and a full T-Coil test was run on that client.

I. WLAN SNNR Vocoder Comparison

Table 7-1
Comparison of SNNR Results
Across Manufacturer-Installed VoIP Clients (using 2.4GHz WLAN)

Client Setting:	Google Hangouts	Skype	Orientation	Channel
ABM1 Pre-test (dBA/m)	0.33	3.26	Axial	1
ABM2 Pre-test (dBA/m) (A-weight, Half-Band Int.)	-48.44	-51.31		
S+N/N (dB)	48.77	54.57		

Notes:

- The Google Hangouts VoIP client was selected for WLAN testing to account for worst-case SNNR results.



Figure 7-1
Audio Band Magnetic Curve Measurement Block Diagram

FCC ID: ACJFZN1A	PCTEST <small>ENGINEERING LABORATORY, INC.</small>	HAC (T-COIL) TEST REPORT		Reviewed by: Quality Manager
Filename: 0Y1601060061.ACJ	Test Dates: 12/31/2015 - 01/05/2016	EUT Type: Portable Handset	Page 19 of 39	

8. TEST SUMMARY

I. T-Coil Test Summary

**Table 8-1
Table of Results for WLAN**



C63.19 Sec.	Mode	Band	Test Description	Minimum Limit*	Measured	Verdict
				<i>dBa/m</i>	<i>dBa/m</i>	<i>PASS/FAIL</i>
8.3.1	WLAN	2.4GHz	Intensity, Axial	-18	0.2	PASS
8.3.1			Intensity, Radial	-18	-7.7	PASS
8.3.4			Signal-to-Noise/Noise, Axial	20	48.6	PASS
8.3.4			Signal-to-Noise/Noise, Radial	20	48.7	PASS
8.3.2			Frequency Response, Axial	0	1.7	PASS
8.3.1	WLAN	5GHz	Intensity, Axial	-18	0.3	PASS
8.3.1			Intensity, Radial	-18	-8.2	PASS
8.3.4			Signal-to-Noise/Noise, Axial	20	49.8	PASS
8.3.4			Signal-to-Noise/Noise, Radial	20	49.5	PASS
8.3.2			Frequency Response, Axial	0	1.8	PASS

Note: The above summary table represents the worst-case numerical values according to configurations in Table 8-3.

**Table 8-2
Consolidated Tabled Results**

		Freq. Response Margin		Magnetic Intensity Verdict		SNNR Verdict		C63.19-2011 RATING
		Axial	Radial	Axial	Radial	Axial	Radial	
WLAN	2.4GHz	PASS	NA	PASS	PASS	PASS	PASS	T4
	5GHz	PASS	NA	PASS	PASS	PASS	PASS	

Note: Result shown is for T-coil category only.

FCC ID: ACJFZN1A		HAC (T-COIL) TEST REPORT		Reviewed by: Quality Manager
Filename: 0Y1601060061.ACJ	Test Dates: 12/31/2015 - 01/05/2016	EUT Type: Portable Handset		Page 20 of 39



II. Raw Handset Data

**Table 8-3
Raw Data Results for WLAN**

		Volume	WLAN 2.4GHz							
			Axial				Radial			
			1	6	11	1 ⁵	1	6	11	11 ⁵
ABM1, dBA/m	Maximum	0.21	0.33	0.33	0.40	-7.70	-7.68	-7.55	-6.38	
ABM2, dBA/m		-48.43	-48.65	-49.41	-53.67	-57.04	-57.69	-56.20	-57.20	
Ambient Noise, dBA/m		-64.71	-64.71	-64.71	-64.71	-63.64	-63.64	-63.64	-63.64	
Freq. Response Margin (dB)		1.82	1.72	1.76	1.73	N/A	N/A	N/A	N/A	
S+N/N (dB)		48.64	48.98	49.74	54.07	49.34	50.01	48.65	50.82	
S+N/N per orientation (dB)		48.64				48.65				
C63.19-2011 Rating per orientation		T4				T4				
		Volume	WLAN 5GHz							
			Axial				Radial			
			36	48	165		36	48	165	
ABM1, dBA/m	Maximum	0.40	0.28	0.27		-7.57	-7.63	-8.23		
ABM2, dBA/m		-50.14	-51.22	-49.54		-57.10	-57.79	-59.87		
Ambient Noise, dBA/m		-64.71	-64.71	-64.71		-63.64	-63.64	-63.64		
Freq. Response Margin (dB)		1.79	1.88	1.82		N/A	N/A	N/A		
S+N/N (dB)		50.54	51.50	49.81		49.53	50.16	51.64		
S+N/N per orientation (dB)		49.81				49.53				
C63.19-2011 Rating per orientation		T4				T4				
T-coil Coordinates (cm)	[x,y] from bottom left	2.4, 2.6				2.4, 1.8				

Notes:

1. Phone Condition: Mute on; Backlight on; Max Volume; Max Contrast
2. 'Radial' orientation refers to radial transverse.
3. The Google VoIP client was used for the WLAN testing for this device. See Section 7 of this report for more information regarding the selection of VoIP clients.
4. Speech Signal: ITU-T P.50 Artificial Voice
5. The worst case configuration for each probe orientation was additionally tested using the L-Battery Accessory.

FCC ID: ACJFZN1A		HAC (T-COIL) TEST REPORT		Reviewed by: Quality Manager
Filename: 0Y1601060061.ACJ	Test Dates: 12/31/2015 - 01/05/2016	EUT Type: Portable Handset		Page 21 of 39

III. Frequency Response Graph

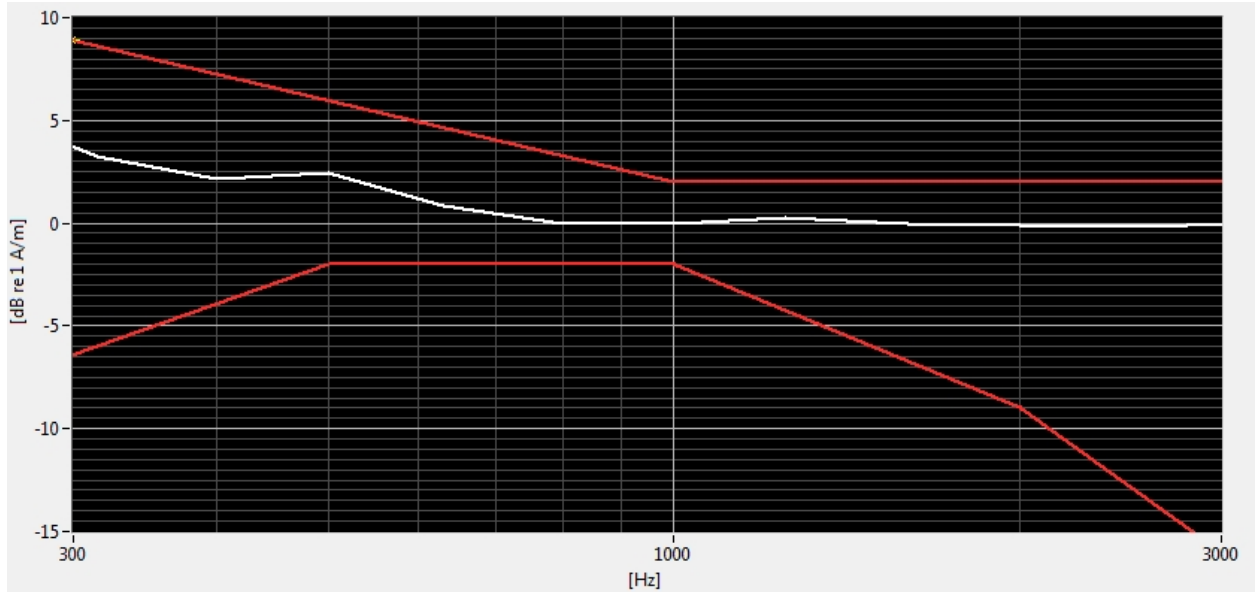

Figure 8-1
Axial Frequency Response

Note: This frequency response represents the worst-case ABM2 test configuration according to Table 8-3.

IV. Undesirable Audio Magnetic Band Plot (ABM2)

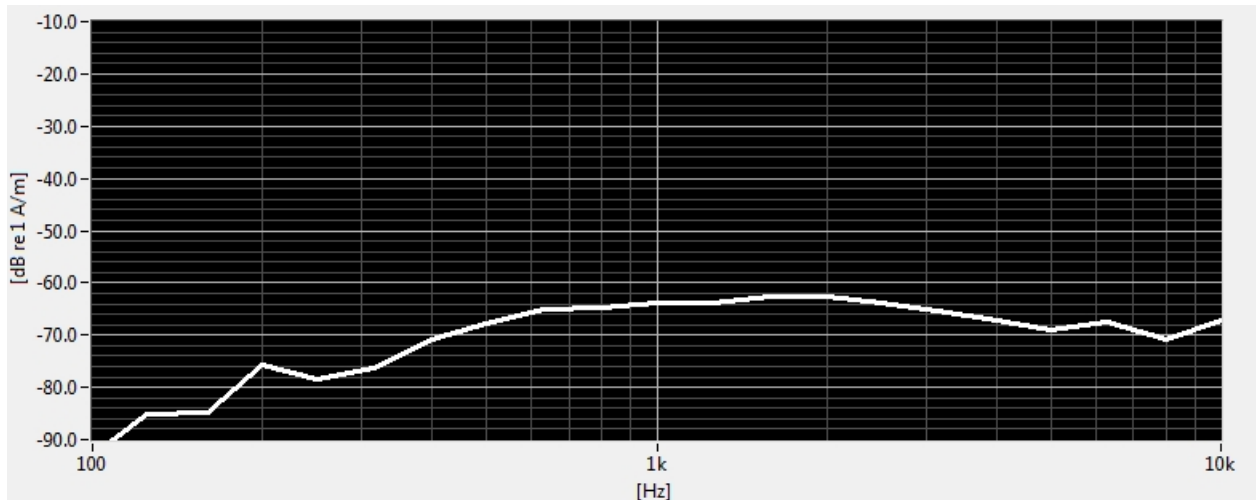



Figure 8-2
Worst-case ABM2 Plot for WLAN

Note: This plot represents the data from the location/configuration resulting in the highest ABM2 result shown in Table 8-3.

FCC ID: ACJFZN1A		HAC (T-COIL) TEST REPORT		Reviewed by: Quality Manager
Filename: OY1601060061.ACJ	Test Dates: 12/31/2015 - 01/05/2016	EUT Type: Portable Handset	Page 22 of 39	

V. T-Coil Validation Test Results

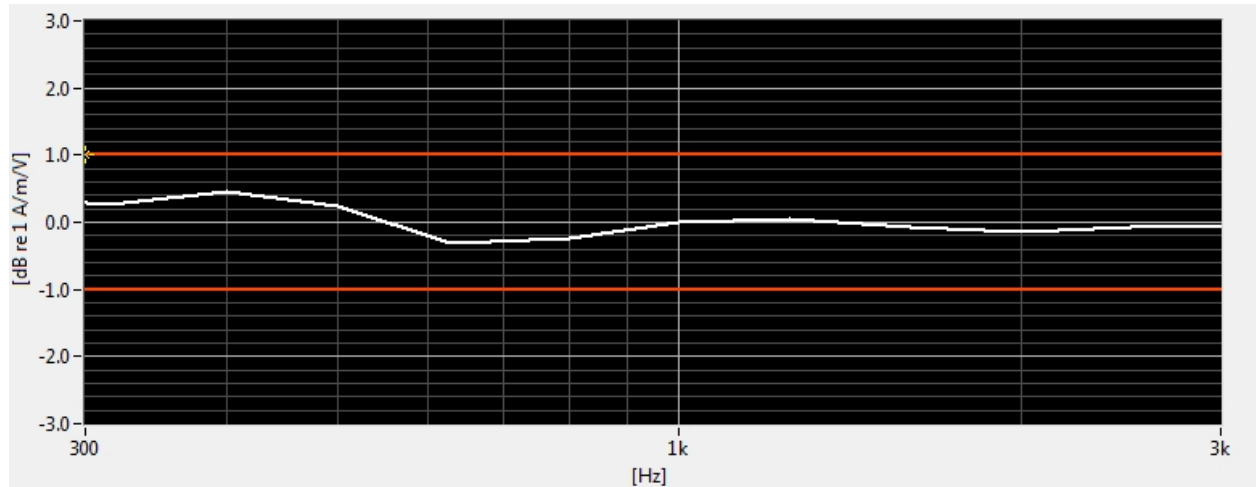



Figure 8-3
Helmholtz Coil Validation for Frequency Response

Table 8-4
Helmholtz Coil Validation Table of Results

Item	Target	Result	Verdict
Axial			
Magnetic Intensity, -10 dBA/m	$-10 \pm 0.5 \text{ dB}$	-10.118	PASS
Environmental Noise	< -58 dBA/m	-64.71	PASS
Frequency Response, from limits	> 0 dB	0.60	PASS
Radial			
Magnetic Intensity, -10 dBA/m	$-10 \pm 0.5 \text{ dB}$	-10.298	PASS
Environmental Noise	< -58 dBA/m	-63.64	PASS
Frequency Response, from limits	> 0 dB	0.60	PASS

FCC ID: ACJFZN1A		HAC (T-COIL) TEST REPORT		Reviewed by: Quality Manager
Filename: 0Y1601060061.ACJ	Test Dates: 12/31/2015 - 01/05/2016	EUT Type: Portable Handset		Page 23 of 39

© 2016 PCTEST Engineering Laboratory, Inc.

REV 3.1.M
11/27/2015

© 2016 PCTEST Engineering Laboratory, Inc. All rights reserved. Unless otherwise specified, no part of this report may be reproduced or utilized in any part, form or by any means, electronic or mechanical, including photocopying and microfilm, without permission in writing from PCTEST Engineering Laboratory, Inc. If you have any questions about this international copyright or have an enquiry about obtaining additional rights to this report or assembly of contents thereof, please contact INFO@PCTESTLAB.COM.

9. MEASUREMENT UNCERTAINTY



**Table 9-1
Uncertainty Estimation Table**

Contribution	Data +/- %	Data +/- dB	Data Type	Probability distribution	Divisor	Standard uncertainty	Standard Uncertainty (dB)
ABM Noise	7.0%	0.29	Std. Dev.	Normal k=1	1.00	7.0%	
RF Reflections	4.7%	0.20	Specification	Rectangular	1.73	2.7%	
Reference Signal Level	12.2%	0.50	Specification	Rectangular	1.73	7.0%	
Positioning Accuracy	10.0%	0.41	Uncertainty	Rectangular	1.73	5.8%	
Probe Coil Sensitivity	12.2%	0.50	Specification	Rectangular	1.73	7.0%	
Probe Linearity	2.4%	0.10	Std. Dev.	Normal k=1	1.00	2.4%	
Cable Loss	2.8%	0.12	Specification	Rectangular	1.73	1.6%	
Frequency Analyzer	5.0%	0.21	Specification	Rectangular	1.73	2.9%	
System Repeatability	5.0%	0.21	Std. Dev.	Normal k=1	1.00	5.0%	
WD Repeatability	9.0%	0.37	Std. Dev.	Normal k=1	1.00	9.0%	
Positioner Accuracy	1.0%	0.04	Specification	Rectangular	1.73	0.6%	
Combined standard uncertainty, u_c (k=1)						17.7%	0.71
Expanded uncertainty (k=2), 95% confidence level						35.3%	1.31

Notes:

1. Test equipments are calibrated according to techniques outlined in NIS81, NIS3003 and NIST Tech Note 1297.
2. All equipments have traceability according to NIST. Measurement Uncertainties are defined in further detail in NIS 81 and NIST Tech Note 1297 and UKAS M3003.



Measurement uncertainty reflects the quality and accuracy of a measured result as compared to the true value. Such statements are generally required when stating results of measurements so that it is clear to the intended audience that the results may differ when reproduced by different facilities. Measurement results vary due to the measurement uncertainty of the instrumentation, measurement technique, and test engineer. Most uncertainties are calculated using the tolerances of the instrumentation used in the measurement, the measurement setup variability, and the technique used in performing the test. While not generally included, the variability of the equipment under test also figures into the overall measurement uncertainty. Another component of the overall uncertainty is based on the variability of repeated measurements (so-called Type A uncertainty). This may mean that the Hearing Aid compatibility tests may have to be repeated by taking down the test setup and resetting it up so that there are a statistically significant number of repeat measurements to identify the measurement uncertainty. By combining the repeat measurement results with that of the instrumentation chain using the technique contained in NIS 81 and NIS 3003, the overall measurement uncertainty was estimated.

FCC ID: ACJFZN1A		HAC (T-COIL) TEST REPORT		Reviewed by: Quality Manager
Filename: 0Y1601060061.ACJ	Test Dates: 12/31/2015 - 01/05/2016	EUT Type: Portable Handset		Page 24 of 39



10. EQUIPMENT LIST

**Table 10-1
Equipment List**

Manufacturer	Model	Description	Cal Date	Cal Interval	Cal Due	Serial Number
Agilent	E4407B	ESA Spectrum Analyzer	11/30/2015	Annual	11/30/2016	US39040349
Bruel & Kjaer	4231	Acoustical Calibrator	N/A	N/A	N/A	2343018
Bruel & Kjaer	4158	Ear Simulator	N/A	N/A	N/A	1886222
Bruel & Kjaer	4128	Head and Torso Simulator	N/A	N/A	N/A	1947220
Bruel & Kjaer	2669	Microphone PreAmplifier	N/A	N/A	N/A	2025786
Listen	SoundConnect	Microphone Power Supply	1/22/2015	Annual	1/22/2016	0899-PS150
Listen	SoundCheck	Acoustic Analyzer System	1/27/2015	Annual	1/27/2016	04-06-5876-SC2850
NI	4474	Data Acquisition Card	N/A		N/A	N/A
TEM	C63.19	Helmholtz Coil	1/29/2015	Annual	1/29/2016	925
TEM	Axial T-Coil Probe	Axial T-Coil Probe	1/29/2015	Annual	1/29/2016	TEM-1123
TEM	Radial T-Coil Probe	Radial T-Coil Probe	1/29/2015	Annual	1/29/2016	TEM-1129
TEM		HAC System Controller with Software	N/A		N/A	N/A
TEM		HAC Positioner	N/A		N/A	N/A

FCC ID: ACJFZN1A		HAC (T-COIL) TEST REPORT		Reviewed by: Quality Manager
Filename: 0Y1601060061.ACJ	Test Dates: 12/31/2015 - 01/05/2016	EUT Type: Portable Handset		Page 25 of 39

11. CALIBRATION CERTIFICATES

FCC ID: ACJFZN1A		HAC (T-COIL) TEST REPORT		Reviewed by: Quality Manager
Filename: 0Y1601060061.ACJ	Test Dates: 12/31/2015 - 01/05/2016	EUT Type: Portable Handset	Page 26 of 39	

© 2016 PCTEST Engineering Laboratory, Inc.

REV 3.1.M
11/27/2015

© 2016 PCTEST Engineering Laboratory, Inc. All rights reserved. Unless otherwise specified, no part of this report may be reproduced or utilized in any part, form or by any means, electronic or mechanical, including photocopying and microfilm, without permission in writing from PCTEST Engineering Laboratory, Inc. If you have any questions about this international copyright or have an enquiry about obtaining additional rights to this report or assembly of contents thereof, please contact INFO@PCTESTLAB.COM.

West Caldwell Calibration Laboratories Inc.

Certificate of Calibration

for

Axial T Coil Probe

Manufactured by: TEM CONSULTING
Model No: Axial T Coil Probe
Serial No: TEM-1123
Calibration Recall No: 24931

Submitted By:

Customer: ANDREW HARWELL
Company: PCTEST ENGINEERING LAB
Address: 6660-B DOBBIN ROAD
COLUMBIA MD 21045

The subject instrument was calibrated to the indicated specification using standards traceable to the National Institute of Standards and Technology or to accepted values of natural physical constants. This document certifies that the instrument met the following specification upon its return to the submitter.

West Caldwell Calibration Laboratories Procedure No. Axial T Coi TEM

Upon receipt for Calibration, the instrument was found to be:

Within (X)

✓ASH
3/17/2015

tolerance of the indicated specification. See attached Report of Calibration.

West Caldwell Calibration Laboratories' calibration control system meets the requirements, ISO 10012-1 MIL-STD-45662A, ANSI/NCSL Z540-1, IEC Guide 25, ISO 9001:2008 and ISO 17025.

Note: With this Certificate, Report of Calibration is included.

Approved by:

Calibration Date: 29-Jan-15

Certificate No: 24931 - 1

QA Doc. #1051 Rev. 2.0 10/1/01



Certificate Page 1 of 1

FC
Felix Christopher (QA Mgr.)
ISO/IEC 17025:2005

West Caldwell Calibration Laboratories, Inc.
uncompromised calibration
1575 State Route 96, Victor, NY 14564, U.S.A.



Calibration Lab. Cert. # 1533.01

FCC ID: ACJFZN1A	 PCTEST ENGINEERING LABORATORY, INC.	HAC (T-COIL) TEST REPORT	 Panasonic	Reviewed by: Quality Manager
Filename: 0Y1601060061.ACJ	Test Dates: 12/31/2015 - 01/05/2016	EUT Type: Portable Handset		Page 27 of 39

© 2016 PCTEST Engineering Laboratory, Inc.

REV 3.1.M
11/27/2015

© 2016 PCTEST Engineering Laboratory, Inc. All rights reserved. Unless otherwise specified, no part of this report may be reproduced or utilized in any part, form or by any means, electronic or mechanical, including photocopying and microfilm, without permission in writing from PCTEST Engineering Laboratory, Inc. If you have any questions about this international copyright or have an enquiry about obtaining additional rights to this report or assembly of contents thereof, please contact INFO@PCTESTLAB.COM.



ISO/IEC 17025: 2005



Calibration Lab. Cert. # 1533.01

REPORT OF CALIBRATION

TEM Consulting LP Axial T Coil Probe

for
Model No.: Axial T Coil Probe

Serial No.: TEM-1123

Company : PCTEST Engineering Lab.

I. D. No: 80582

Calibration results:		Before data:	After data:
Probe Sensitivity measured with Helmholtz Coil			
<i>Helmholtz Coil;</i>			
the number of turns on each coil;	10	No.	Before & after data same: ... X.....
the radius of each coil, in meters;	0.204	m	
the current in the coils, in amperes.;	0.09	A	
<i>Helmholtz Coil Constant;</i>	7.09	A/m/V	Laboratory Environment:
<i>Helmholtz Coil magnetic field;</i>	6.08	A/m	Ambient Temperature: 21.0 °C
			Ambient Humidity: 25.4 % RH
			Ambient Pressure: 99.5 kPa
			Calibration Date: 29-Jan-15
Probe Sensitivity at	1000	Hz.	Re-calibration Due: 29-Jan-16
was	-60.13	dBV/A/m	Report Number: 24931 -1
	0.985	mV/A/m	Control Number: 24931
Probe resistance	892	Ohms	

The above listed instrument meets or exceeds the tested manufacturer's specifications.

This Calibration is traceable through NIST test numbers: 683/284413-14
 The expanded uncertainty of calibration: 0.30dB at 95% confidence level with a coverage factor of k=2.
 Graph represents Probes Frequency Response.

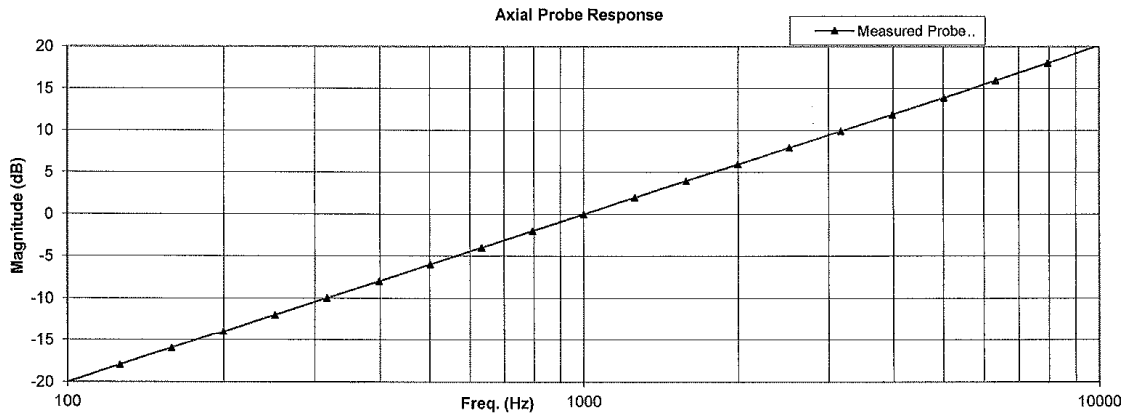

The above listed instrument was checked using calibration procedure documented in West Caldwell Calibration Laboratories Inc. procedure : **Rev. 7.0 Jan. 24, 2014 Doc. # 1038 HCATEMC**
 Calibration was performed by West Caldwell Calibration Laboratories Inc. under Operating Procedures intended to implement the requirements of ISO10012-1, IEC Guide 25, ANSI/NCSL Z540-1, (MIL-STD-45662A) and ISO 9001:2008, ISO 17025

Cal. Date: 29-Jan-2015
 Calibrated on WCCL system type 9700
 Measurements performed by: *[Signature]*
Felix Christopher
 This document shall not be reproduced, except in full, without the written approval from West Caldwell Cal. Labs. Inc. Rev. 7.0 Jan. 24, 2014 Doc. # 1038 HCATEMC

FCC ID: ACJFZN1A		HAC (T-COIL) TEST REPORT		Reviewed by: Quality Manager
Filename: OY1601060061.ACJ	Test Dates: 12/31/2015 - 01/05/2016	EUT Type: Portable Handset		Page 28 of 39

HCATEMC_TEM-1123_Jan-29-2015

West Caldwell Calibration Laboratories Inc.

1575 State Route 96, Victor NY 14564
Tel. (585) 586-3900 FAX (585) 586-4327

Calibration Data Record

TEM Consulting LP Axial T Coil Probe

for
Model No.: Axial T Coil Probe

Serial No.: TEM-1123

Company : PCTEST Engineering Lab.

Test	Function	Tolerance	Measured values		
			Before	Out	Remarks
1.0	Probe Sensitivity at	1000 Hz. dBV/A/m	-60.13		
2.0	Probe Level Linearity	dB			
		6	5.57		
		0	0.00		
		-6	-5.95		
		-12	-11.95		
3.0	Probe Frequency Response	Hz			
		100	-20.0		
		126	-17.9		
		158	-15.9		
		200	-14.0		
		251	-12.0		
		316	-10.0		
		398	-8.0		
		501	-6.0		
		631	-4.0		
		794	-2.0		
		1000	0.0		
		1259	2.0		
		1585	4.0		
		1995	6.0		
		2512	7.9		
		3162	9.9		
		3981	11.9		
		5012	13.9		
		6310	15.9		
7943	18.0				
10000	20.2				

Instruments used for calibration:			Date of Cal.	Traceability No.	Due Date
HP	34401A	S/N 36064102	6-Oct-2014	,287708	6-Oct-2015
HP	34401A	S/N 36102471	6-Oct-2014	,287708	6-Oct-2015
HP	33120A	S/N 36043716	6-Oct-2014	,287708	6-Oct-2015
B&K	2133	S/N 1583254	8-Jan-2015	683/284413-14	9-Jan-2016

Cal. Date: 29-Jan-2015



Tested by: Felix Christopher

Calibrated on WCCL system type 9700

This document shall not be reproduced, except in full, without the written approval from West Caldwell Cal. Labs. Inc.

Rev. 7.0 Jan. 24, 2014 Doc. # 1038 HCATEMC

Page 2 of 2

FCC ID: ACJFZN1A		HAC (T-COIL) TEST REPORT		Reviewed by: Quality Manager
Filename: OY1601060061.ACJ	Test Dates: 12/31/2015 - 01/05/2016	EUT Type: Portable Handset		Page 29 of 39

© 2016 PCTEST Engineering Laboratory, Inc.

REV 3.1.M
11/27/2015

© 2016 PCTEST Engineering Laboratory, Inc. All rights reserved. Unless otherwise specified, no part of this report may be reproduced or utilized in any part, form or by any means, electronic or mechanical, including photocopying and microfilm, without permission in writing from PCTEST Engineering Laboratory, Inc. If you have any questions about this international copyright or have an enquiry about obtaining additional rights to this report or assembly of contents thereof, please contact INFO@PCTESTLAB.COM.

West Caldwell Calibration Laboratories Inc.

Certificate of Calibration

for

Radial T Coil Probe

Manufactured by: TEM CONSULTING
Model No: Radial T Coil Probe
Serial No: TEM-1129
Calibration Recall No: 24931

Submitted By:

Customer: ANDREW HARWELL
Company: PCTEST ENGINEERING LAB
Address: 6660-B DOBBIN ROAD
COLUMBIA MD 21045

The subject instrument was calibrated to the indicated specification using standards traceable to the National Institute of Standards and Technology or to accepted values of natural physical constants. This document certifies that the instrument met the following specification upon its return to the submitter.

West Caldwell Calibration Laboratories Procedure No. Radial T C TEM

Upon receipt for Calibration, the instrument was found to be:

Within (X)

✓ASH
3/17/2015

tolerance of the indicated specification. See attached Report of Calibration.

West Caldwell Calibration Laboratories' calibration control system meets the requirements, ISO 10012-1 MIL-STD-45662A, ANSI/NCSL Z540-1, IEC Guide 25, ISO 9001:2008 and ISO 17025.

Note: With this Certificate, Report of Calibration is included.

Approved by:

Calibration Date: 29-Jan-15

Certificate No: 24931 - 2

QA Doc. #1051 Rev. 2.0 10/1/01



Certificate Page 1 of 1

FC
Felix Christopher (QA Mgr.)
ISO/IEC 17025:2005

West Caldwell Calibration Laboratories, Inc.
uncompromised calibration
1575 State Route 96, Victor, NY 14564, U.S.A.



Calibration Lab. Cert. # 1533.01

FCC ID: ACJFZN1A	 PCTEST ENGINEERING LABORATORY, INC.	HAC (T-COIL) TEST REPORT	 Panasonic	Reviewed by: Quality Manager
Filename: OY1601060061.ACJ	Test Dates: 12/31/2015 - 01/05/2016	EUT Type: Portable Handset		Page 30 of 39

© 2016 PCTEST Engineering Laboratory, Inc.

REV 3.1.M
11/27/2015

© 2016 PCTEST Engineering Laboratory, Inc. All rights reserved. Unless otherwise specified, no part of this report may be reproduced or utilized in any part, form or by any means, electronic or mechanical, including photocopying and microfilm, without permission in writing from PCTEST Engineering Laboratory, Inc. If you have any questions about this international copyright or have an enquiry about obtaining additional rights to this report or assembly of contents thereof, please contact INFO@PCTESTLAB.COM.



ISO/IEC 17025: 2005



Calibration Lab. Cert. # 1533.01

REPORT OF CALIBRATION

TEM Consulting LP Radial T Coil Probe

Model No.: Radial T Coil Probe

Serial No.: TEM-1129

Company : PCTEST Engineering Lab.

I. D. No: 80583

Calibration results:		Before data:	After data:
Probe Sensitivity measured with Helmholtz Coil			
<i>Helmholtz Coil;</i>			
the number of turns on each coil;	10	No.	
the radius of each coil, in meters;	0.204	m	
the current in the coils, in amperes.;	0.09	A	
<i>Helmholtz Coil Constant;</i>	7.09	A/m/V	
<i>Helmholtz Coil magnetic field;</i>	5.99	A/m	
Probe Sensitivity at	1000	Hz.	
was	-60.44	dBV/A/m	
	0.950	mV/A/m	
Probe resistance	892	Ohms	
			Before & after data same: ...X.....
			Laboratory Environment:
		Ambient Temperature:	21.0 °C
		Ambient Humidity:	25.4 % RH
		Ambient Pressure:	99.5 kPa
		Calibration Date:	29-Jan-15
		Re-calibration Due:	29-Jan-16
		Report Number:	24931 -2
		Control Number:	24931

The above listed instrument meets or exceeds the tested manufacturer's specifications.

This Calibration is traceable through NIST test numbers: 683/284413-14

The expanded uncertainty of callibration: 0.30dB at 95% confidence level with a coverage factor of k=2.

Graph represents Probes Frequency Response.

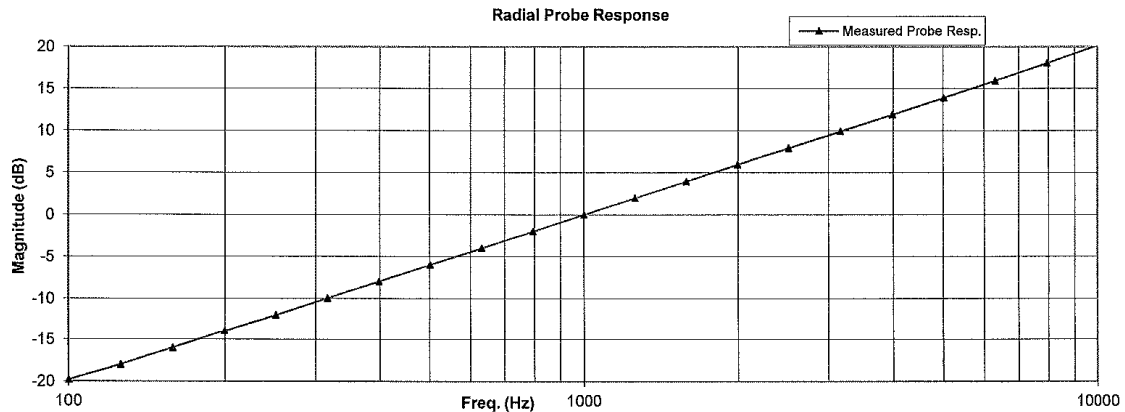

The above listed instrument was checked using calibration procedure documented in West Caldwell

Calibration Laboratories Inc. procedure :

Rev. 7.0 Jan. 24, 2014 Doc. # 1038 HCRTEMC

Calibration was performed by West Caldwell Calibration Laboratories Inc. under Operating Procedures

intended to implement the requirements of ISO10012-1, IEC Guide 25, ANSI/NCSL Z540-1, (MIL-STD-45662A) and ISO 9001:2008, ISO 17025

Cal. Date: 29-Jan-2015

Measurements performed by: *[Signature]*

Calibrated on WCCL system type 9700

Felix Christopher

This document shall not be reproduced, except in full, without the written approval from West Caldwell Cal. Labs. Inc.

Rev. 7.0 Jan. 24, 2014 Doc. # 1038 HCRTEMC

FCC ID: ACJFZN1A	PCTEST ENGINEERING LABORATORY, INC.	HAC (T-COIL) TEST REPORT	Panasonic	Reviewed by: Quality Manager
Filename: OY1601060061.ACJ	Test Dates: 12/31/2015 - 01/05/2016	EUT Type: Portable Handset		Page 31 of 39

HCRTEMC_TEM-1129_Jan-29-2015

West Caldwell Calibration Laboratories Inc.

1575 State Route 96, Victor NY 14564
Tel. (585) 586-3900 FAX (585) 586-4327



Calibration Data Record

for
TEM Consulting LP Radial T Coil Probe Model No.: Radial T Coil Probe Serial No.: TEM-1129
Company : PCTEST Engineering Lab.

Test	Function	Tolerance	Measured values			
			Before	Out	Remarks	
1.0	Probe Sensitivity at	1000 Hz. dBV/A/m	-60.44			
2.0	Probe Level Linearity					
			dB	5.99		
		Ref. (0 dB)	0	0.00		
			-6	-6.02		
		-12	-12.04			
3.0	Probe Frequency Response		Hz			
			100	-19.8		
			126	-18.0		
			158	-16.0		
			200	-13.9		
			251	-12.0		
			316	-10.0		
			398	-8.0		
			501	-6.0		
			631	-4.0		
			794	-2.0		
			Ref. (0 dB)	1000	0.0	
				1259	2.0	
				1585	4.0	
				1995	6.0	
				2512	7.9	
				3162	9.9	
		3981	11.9			
		5012	13.9			
		6310	16.0			
		7943	18.0			
		10000	20.2			

Instruments used for calibration:			Date of Cal.	Traceability No.	Due Date
HP	34401A	S/N 36064102	6-Oct-2014	,287708	6-Oct-2015
HP	34401A	S/N 36102471	6-Oct-2014	,287708	6-Oct-2015
HP	33120A	S/N 36043716	6-Oct-2014	,287708	6-Oct-2015
B&K	2133	S/N 1583254	8-Jan-2015	683/284413-14	9-Jan-2016



Cal. Date: 29-Jan-2015 Tested by: Felix Christopher
Calibrated on WCCL system type 9700
This document shall not be reproduced, except in full, without the written approval from West Caldwell Cal. Labs. Inc. Rev. 7.0 Jan. 24, 2014 Doc. # 1038 HCRTEMC

FCC ID: ACJFZN1A		HAC (T-COIL) TEST REPORT		Reviewed by: Quality Manager
Filename: OY1601060061.ACJ	Test Dates: 12/31/2015 - 01/05/2016	EUT Type: Portable Handset		Page 32 of 39

12. CONCLUSION

The measurements indicate that the wireless communications device complies with the HAC limits specified in accordance with the ANSI C63.19 Standard. Precise laboratory measures were taken to assure repeatability of the tests. The tested device complies with the requirements in respect to all parameters specific to the test. The test results and statements relate only to the item(s) tested.

The measurement system and techniques presented in this evaluation are proposed in the ANSI standard as a means of best approximating wireless device compatibility with a hearing-aid. The literature is under continual re-construction.

FCC ID: ACJFZN1A		HAC (T-COIL) TEST REPORT		Reviewed by: Quality Manager
Filename: 0Y1601060061.ACJ	Test Dates: 12/31/2015 - 01/05/2016	EUT Type: Portable Handset	Page 33 of 39	



© 2016 PCTEST Engineering Laboratory, Inc.

REV 3.1.M
11/27/2015

© 2016 PCTEST Engineering Laboratory, Inc. All rights reserved. Unless otherwise specified, no part of this report may be reproduced or utilized in any part, form or by any means, electronic or mechanical, including photocopying and microfilm, without permission in writing from PCTEST Engineering Laboratory, Inc. If you have any questions about this international copyright or have an enquiry about obtaining additional rights to this report or assembly of contents thereof, please contact INFO@PCTESTLAB.COM.

13. REFERENCES

1. ANSI C63.19-2011, American National Standard for Methods of Measurement of Compatibility between Wireless communication devices and Hearing Aids.", New York, NY, IEEE, May 2011
2. Berger, H. S., "Compatibility Between Hearing Aids and Wireless Devices," Electronic Industries Forum, Boston, MA, May, 1997
3. Berger, H. S., "Hearing Aid and Cellular Phone Compatibility: Working Toward Solutions," Wireless Telephones and Hearing Aids: New Challenges for Audiology, Gallaudet University, Washington, D.C., May, 1997 (To be reprinted in the American Journal of Audiology).
4. Berger, H. S., "Hearing Aid Compatibility with Wireless Communications Devices," IEEE International Symposium on Electromagnetic Compatibility, Austin, TX, August, 1997.
5. Bronaugh, E. L., "Simplifying EMI Immunity (Susceptibility) Tests in TEM Cells," in the 1990 IEEE International Symposium on Electromagnetic Compatibility Symposium Record, Washington, D.C., August 1990, pp. 488-491
6. Byrne, D. and Dillon, H., The National Acoustics Laboratory (NAL) New Procedure for Selecting the Gain and Frequency Response of a Hearing Aid, Ear and Hearing 7:257-265, 1986.
7. Crawford, M. L., "Measurement of Electromagnetic Radiation from Electronic Equipment using TEM Transmission Cells," U.S. Department of Commerce, National Bureau of Standards, NBSIR 73-306, Feb. 1973.
8. Crawford, M. L., and Workman, J. L., "Using a TEM Cell for EMC Measurements of Electronic Equipment," U.S. Department of Commerce, National Bureau of Standards. Technical Note 1013, July 1981.
9. EHIMA GSM Project, Development phase, Project Report (1st part) Revision A. Technical-Audiological Laboratory and Telecom Denmark, October 1993.
10. EHIMA GSM Project, Development phase, Part II Project Report. Technical-Audiological Laboratory and Telecom Denmark, June 1994.
11. EHIMA GSM Project Final Report, Hearing Aids and GSM Mobile Telephones: Interference Problems, Methods of Measurement and Levels of Immunity. Technical-Audiological Laboratory and Telecom Denmark, 1995.
12. HAMPIS Report, Comparison of Mobile phone electromagnetic near field with an upscaled electromagnetic far field, using hearing aid as reference, 21 October 1999.
13. Hearing Aids/GSM, Report from OTWIDAM, Technical-Audiological Laboratory and Telecom Denmark, April 1993.
14. IEEE 100, The Authoritative Dictionary of IEEE Standards Terms, Seventh Edition.
15. Joyner, K. H, et. al., Interference to Hearing Aids by the New Digital Mobile Telephone System, Global System for Mobile (GSM) Communication Standard, National Acoustic Laboratory, Australian Hearing Series, Sydney 1993.

FCC ID: ACJFZN1A		HAC (T-COIL) TEST REPORT		Reviewed by: Quality Manager
Filename: 0Y1601060061.ACJ	Test Dates: 12/31/2015 - 01/05/2016	EUT Type: Portable Handset		Page 34 of 39



© 2016 PCTEST Engineering Laboratory, Inc.

REV 3.1.M

11/27/2015

© 2016 PCTEST Engineering Laboratory, Inc. All rights reserved. Unless otherwise specified, no part of this report may be reproduced or utilized in any part, form or by any means, electronic or mechanical, including photocopying and microfilm, without permission in writing from PCTEST Engineering Laboratory, Inc. If you have any questions about this international copyright or have an enquiry about obtaining additional rights to this report or assembly of contents thereof, please contact INFO@PCTESTLAB.COM.

16. Joyner, K. H., et. al., Interference to Hearing Aids by the Digital Mobile Telephone System, Global System for Mobile Communications (GSM), NAL Report #131, National Acoustic Laboratory, Australian Hearing Series, Sydney, 1995.
17. Kecker, W. T., Crawford, M. L., and Wilson, W. A., "Construction of a Transverse Electromagnetic Cell", U.S. Department of Commerce, National Bureau of Standards, Technical Note 1011, Nov. 1978.
18. Konigstein, D., and Hansen, D., "A New Family of TEM Cells with enlarged bandwidth and Optimized working Volume," in the Proceedings of the 7th International Symposium on EMC, Zurich, Switzerland, March 1987; 50:9, pp. 127-132.
19. Kuk, F., and Hjorstgaard, N. K., "Factors affecting interference from digital cellular telephones," Hearing Journal, 1997; 50:9, pp 32-34.
20. Ma, M. A., and Kanda, M., "Electromagnetic Compatibility and Interference Metrology," U.S. Department of Commerce, National Bureau of Standards, Technical Note 1099, July 1986, pp. 17-43.
21. Ma, M. A., Sreenivashiah, I. , and Chang, D. C., "A Method of Determining the Emission and Susceptibility Levels of Electrically Small Objects Using a TEM Cell," U.S. Department of Commerce, National Bureau of Standards, Technical Note 1040, July 1981.
22. McCandless, G. A., and Lyregaard, P. E., Prescription of Gain/Output (POGO) for Hearing Aids, Hearing Instruments 1:16-21, 1983
23. Skopec, M., "Hearing Aid Electromagnetic Interference from Digital Wireless Telephones, "IEEE Transactions on Rehabilitation Engineering, vol. 6, no. 2, pp. 235-239, June 1998.
24. Technical Report, GSM 05.90, GSM EMC Considerations, European Telecommunications Standards Institute, January 1993.
25. Victorian, T. A., "Digital Cellular Telephone Interference and Hearing Aid Compatibility—an Update," Hearing Journal 1998; 51:10, pp. 53-60
26. Wong, G. S. K., and Embleton, T. F. W., eds., AIP Handbook of Condenser Microphones: Theory, Calibration and Measurements, AIP Press.

FCC ID: ACJFZN1A		HAC (T-COIL) TEST REPORT		Reviewed by: Quality Manager
Filename: 0Y1601060061.ACJ	Test Dates: 12/31/2015 - 01/05/2016	EUT Type: Portable Handset		Page 35 of 39

© 2016 PCTEST Engineering Laboratory, Inc.

REV 3.1.M
11/27/2015

© 2016 PCTEST Engineering Laboratory, Inc. All rights reserved. Unless otherwise specified, no part of this report may be reproduced or utilized in any part, form or by any means, electronic or mechanical, including photocopying and microfilm, without permission in writing from PCTEST Engineering Laboratory, Inc. If you have any questions about this international copyright or have an enquiry about obtaining additional rights to this report or assembly of contents thereof, please contact INFO@PCTESTLAB.COM.