

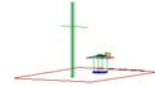

# PCTEST ENGINEERING LABORATORY, INC.

7185 Oakland Mills Road, Columbia, MD 21045 USA  
Tel. 410.290.6652 / Fax 410.290.6654  
http://www.pctestlab.com



## MEASUREMENT REPORT FCC PART 15.407 DFS

**Company Name:**  
Panasonic Corporation of North America  
Two Riverfront Plaza, 9th Floor  
Newark, NJ 07102  
United States

**Date of Testing:**  
06/04-07/8/2014  
**Test Site/Location:**  
PCTEST Lab. Columbia, MD, USA  
**Test Report Serial No.:**  
0Y1409171935.ACJ

<b>FCC ID:</b>	<b>ACJFZE1A</b>
<b>COMPANY:</b>	<b>Panasonic Corporation of North America</b>



**Model(s):** FZ-E1  
**EUT Type:** Portable Handset  
**Type of Device:** Client Only Device, No Radar Detection Capability  
**Frequency Range:** 5260 – 5320 MHz (UNII-2A Band)  
5500 – 5700 MHz (UNII-2C Band)  
**Output Power:** 38.282 mW (15.83 dBm) Conducted (802.11n UNII Band 2A)  
41.591 mW (16.19 dBm) Conducted (802.11n UNII Band 2C)  
**FCC Classification:** Unlicensed National Information Infrastructure (UNII)  
**Test Procedure(s):** KDB 905462 D02 v01, KDB 905462 D03 v01  
**FCC Rule Part(s):** Part 15.407(UNII)

This equipment has been shown to be capable of compliance with the applicable technical standards as indicated in the measurement report and was tested in accordance with the measurement procedures specified in KDB 905462 D02 v01. Test results reported herein relate only to the item(s) tested.

I attest to the accuracy of data. All measurements reported herein were performed by me or were made under my supervision and are correct to the best of my knowledge and belief. I assume full responsibility for the completeness of these measurements and vouch for the qualifications of all persons taking them.

  
Randy Ortanez  
President





FCC ID: ACJFZE1A		FCC Pt. 15.407 DFS TEST REPORT (CERTIFICATION)		Reviewed by: Quality Manager
Test Report S/N: 0Y1409171935.ACJ	Test Dates: 06/04-07/8/2014	EUT Type: Portable Handset		Page 1 of 15

# TABLE OF CONTENTS

---

FCC PART 15.407 MEASUREMENT REPORT .....		3
1.0 INTRODUCTION.....		4
1.1 SCOPE.....		4
1.2 EVALUATION PROCEDURE.....		4
1.3 SUMMARY OF TEST RESULTS .....		4
2.0 PRODUCT INFORMATION .....		5
2.1 EQUIPMENT DESCRIPTION.....		5
2.2 EUT CAPABILITIES.....		5
2.3 MODIFICATIONS.....		5
3.0 DESCRIPTION OF DYNAMIC FREQUENCY SELECTION TEST .....		6
3.1 APPLICABILITY .....		6
3.2 REQUIREMENTS .....		6
3.3 DFS DETECTION THRESHOLD VALUES .....		8
3.4 PARAMETERS OF DFS TEST SIGNALS.....		8
3.5 PROCEDURE .....		9
4.0 TEST EQUIPMENT.....		10
4.1 ADDITIONAL EQUIPMENT .....		10
5.0 TEST RESULTS .....		11
6.0 CONCLUSION .....		15

<b>FCC ID:</b> ACJFZE1A		<b>FCC Pt. 15.407 DFS TEST REPORT (CERTIFICATION)</b>		<b>Reviewed by:</b> Quality Manager
<b>Test Report S/N:</b> 0Y1409171935.ACJ	<b>Test Dates:</b> 06/04-07/8/2014	<b>EUT Type:</b> Portable Handset		Page 2 of 15

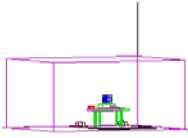

# DFS MEASUREMENT REPORT

## FCC Part 15.407

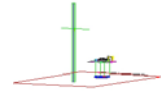

### § 2.1033 General Information



**APPLICANT:** Panasonic Corporation of North America  
**APPLICANT ADDRESS:** Two Riverfront Plaza, 9th Floor  
 Newark, NJ 07102, United States  
**TEST SITE:** PCTEST ENGINEERING LABORATORY, INC.  
**TEST SITE ADDRESS:** 7185 Oakland Mills Road, Columbia, MD 21046 USA  
**FCC RULE PART(S):** Part 15.407(h)  
**BASE MODEL:** FZ-E1  
**FCC ID:** ACJFZE1A  
**Test Device Serial No.:** 03JUNE-7       Production     Pre-Production     Engineering  
**DEVICE CLASSIFICATION:** Client Only, No Radar Detection  
**DATE(S) OF TEST:** 06/04-07/8/2014  
**TEST REPORT S/N:** 0Y1409171935.ACJ

### Test Facility / Accreditations

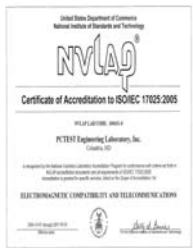
Measurements were performed at PCTEST Engineering Lab located in Columbia, MD 21045, U.S.A.



- PCTEST facility is an FCC registered (PCTEST Reg. No. 159966) test facility with the site description report on file and has met all the requirements specified in Section 2.948 of the FCC Rules and Industry Canada (2451B-1).
- PCTEST Lab is accredited to ISO 17025 by U.S. National Institute of Standards and Technology (NIST) under the National Voluntary Laboratory Accreditation Program (NVLAP Lab code: 100431-0) in EMC, FCC and Telecommunications.
- PCTEST Lab is accredited to ISO 17025-2005 by the American Association for Laboratory Accreditation (A2LA) in Specific Absorption Rate (SAR) testing, Hearing Aid Compatibility (HAC) testing, CTIA Test Plans, and wireless testing for FCC and Industry Canada Rules.
- PCTEST Lab is a recognized U.S. Conformity Assessment Body (CAB) in EMC and R&TTE (n.b. 0982) under the U.S.-EU Mutual Recognition Agreement (MRA).
- PCTEST TCB is a Telecommunication Certification Body (TCB) accredited to ISO/IEC Guide 65 by the American National Standards Institute (ANSI) in all scopes of FCC Rules and Industry Canada Standards (RSS).
- PCTEST facility is an IC registered (2451B-1) test laboratory with the site description on file at Industry Canada.
- PCTEST is a CTIA Authorized Test Laboratory (CATL) for AMPS, CDMA, and EvDO wireless devices and for Over-the-Air (OTA) Antenna Performance testing for AMPS, CDMA, GSM, GPRS, EGPRS, UMTS (W-CDMA), CDMA 1xEVDO, and CDMA 1xRTT.

<b>FCC ID:</b> ACJFZE1A	 <b>FCC Pt. 15.407 DFS TEST REPORT</b> <b>(CERTIFICATION)</b>		<b>Reviewed by:</b> Quality Manager
<b>Test Report S/N:</b> 0Y1409171935.ACJ	<b>Test Dates:</b> 06/04-07/8/2014	<b>EUT Type:</b> Portable Handset	Page 3 of 15

## 1.0 INTRODUCTION

### 1.1 Scope

This report has been prepared to demonstrate compliance with the requirements for Dynamic Frequency Selection (DFS) as stated in KDB 905462 D02 v01. Testing was performed on the **Panasonic Portable Handset**

**FCC ID: ACJFZE1A** in accordance with the measurement procedure described in KDB 905462 D02 v01. As of July 20, 2007 all devices operating in the 5250 – 5350 MHz and/or the 5470 – 5725 MHz bands must comply with the DFS requirements. As the EUT does not have radar detection capability it was evaluated as a Client Only Device. All test results reported herein are applicable to the sample selected for testing. The unit used for testing was supplied by Panasonic Corporation of North America.

### 1.2 Evaluation Procedure



Conducted test methodology was used for the DFS evaluation procedure of the **Portable Handset**. No deviations to the test procedure and test methods occurred during the evaluation of the EUT.

### 1.3 Summary of Test Results

The **Portable Handset** was found to be compliant with the requirements for DFS as required for a Client Device per Part 15.407(h) and KDB 905462 D02 v01. The following table lists the measured parameters. The actual data and plots can be found in Section 5 and 6 of this report.

	Parameter	Measured	Limit	Result
<b>5260 – 5320 MHz UNII – 2A Band</b>	Channel Move Time	25.706 ms	10 seconds	Pass
	Channel Closing Transmission Time	< 200ms + 0.00 ms (aggregate)	200ms + aggregate of 60ms over remaining 10 second period	Pass
	Non-occupancy Period	Monitored > 30 minutes (No transmission occurred)	30 minutes	Pass
<b>5470 – 5725 MHz UNII – 2C Band</b>	Channel Move Time	33.018 ms	10 seconds	Pass
	Channel Closing Transmission Time	< 200ms + 0.07 ms (aggregate)	200ms + aggregate of 60ms over remaining 10 second period	Pass
	Non-occupancy Period	Monitored > 30 minutes (No transmission occurred)	30 minutes	Pass

**Table 1-1. DFS Test Results Summary**

FCC ID: ACJFZE1A		FCC Pt. 15.407 DFS TEST REPORT (CERTIFICATION)		Reviewed by: Quality Manager
Test Report S/N: 0Y1409171935.ACJ	Test Dates: 06/04-07/8/2014	EUT Type: Portable Handset	Page 4 of 15	

## 2.0 PRODUCT INFORMATION

### 2.1 Equipment Description

The Equipment Under Test (EUT) is the **Panasonic Portable Handset FCC ID: ACJFZE1A**.

**Mode of Operation:**

<b>Master Device</b>	<input type="checkbox"/>
<b>Client Device (No radar detection)</b>	<input checked="" type="checkbox"/>
<b>Client Device with Radar Detection</b>	<input type="checkbox"/>

Parameters of EUT:	
Frequency	5260 – 5320 MHz 5500 – 5700 MHz
Output Power:	38.282 mW (15.83 dBm) Conducted (802.11n UNII Band 2A) 41.591 mW (16.19 dBm) Conducted (802.11n UNII Band 2C)
Modulation:	OFDM
Channel Bandwidth:	20, 40, 80 MHz

### 2.2 EUT Capabilities



This device contains the following capabilities:

850/1900 CDMA (BC0, BC1), 850/1900 GSM/GPRS/EDGE, 850/1900 WCDMA/HSPA, Multi-band LTE, 802.11a/b/g/n/ac WLAN, 802.11a/n/ac UNII, Bluetooth (1x, EDR, LE), NFC

The data shown in this report was taken from a previously certified device (FCC ID: ACJFZE1B) whose circuitry is electrically identical to this device.

### 2.3 Modifications

No modifications to the EUT were required in order to comply with the DFS specifications.

FCC ID: ACJFZE1A		FCC Pt. 15.407 DFS TEST REPORT (CERTIFICATION)		Reviewed by: Quality Manager
Test Report S/N: 0Y1409171935.ACJ	Test Dates: 06/04-07/8/2014	EUT Type: Portable Handset	Page 5 of 15	

## 3.0 DESCRIPTION OF DYNAMIC FREQUENCY SELECTION TEST

### 3.1 Applicability

The following table from KDB 905462 D02 v01 lists the applicable requirements for the DFS testing. The device evaluated in this report is considered a client device without radar detection capability.

Requirement	Operational Mode		
	Master	Client Without Radar Detection	Client With Radar Detection
Non-Occupancy Period	Yes	Not required	Yes
DFS Detection Threshold	Yes	Not required	Yes
Channel Availability Check Time	Yes	Not required	Not required
U-NII Detection Bandwidth	Yes	Not required	Yes

**Table 3-1. DFS Applicability**

Requirement	Operational Mode		
	Master	Client Without Radar Detection	Client With Radar Detection
DFS Detection Threshold	Yes	Not required	Yes
Channel Closing Transmission Time	Yes	Yes	Yes
Channel Move Time	Yes	Yes	Yes
U-NII Detection Bandwidth	Yes	Not required	Yes

**Table 3-2. DFS Applicability During Normal Operation**



Additional requirements for devices with multiple bandwidth modes	Master Device or Client with Radar Detection	Client Without Radar Detection
U-NII Detection Bandwidth and Statistical Performance Check	All BW modes must be tested	Not required
Channel Move Time and Channel Closing Transmission Time	Test using widest BW mode available	Test using the widest BW mode available for the link
All other tests	Any single BW mode	Not required

**Table 3-3. DFS Applicability During Normal Operation**

### 3.2 Requirements

Per KDB 905462 D02 v01 the following are the requirements for Client Devices:

- a) A Client Device will not transmit before having received appropriate control signals from a Master Device.
- b) A Client Device will stop all its transmissions whenever instructed by a Master Device to which it is associated and will meet the Channel Move Time and Channel Closing Transmission Time requirements. The Client Device will not resume any transmissions until it has again received control signals from a Master Device.



FCC ID: ACJFZE1A		FCC Pt. 15.407 DFS TEST REPORT (CERTIFICATION)		Reviewed by: Quality Manager
Test Report S/N: 0Y1409171935.ACJ	Test Dates: 06/04-07/8/2014	EUT Type: Portable Handset	Page 6 of 15	

- c) If a Client Device is performing In-Service Monitoring and detects a Radar Waveform above the DFS Detection Threshold, it will inform the Master Device. This is equivalent to the Master Device detecting the Radar Waveform and d) through f) of section 5.1.1 apply.
- d) Irrespective of Client Device or Master Device detection the Channel Move Time and Channel Closing Transmission Time requirements remain the same.
- e) The client test frequency must be monitored to ensure no transmission of any type has occurred for 30 minutes. Note: If the client moves with the master, the device is considered compliant if nothing appears in the client non-occupancy period test. For devices that shut down (rather than moving channels), no beacons should appear.

Channel Move Time and Channel Closing Transmission Time requirements are listed in the following table.

Parameter	Value
Non-occupancy period	Minimum 30 minutes
Channel Availability Check Time	60 seconds
Channel Move Time	10 seconds See Note 1.
Channel Closing Transmission Time	200 milliseconds + an aggregate of 60 milliseconds over remaining 10 second period. See Notes 1 and 2.
U-NII Detection Bandwidth	Minimum 100% of the U-NII 99% transmission power bandwidth. See Note 3.
<p><b>Note 1:</b> Channel Move Time and the Channel Closing Transmission Time should be performed with Radar Type 0. The measurement timing begins at the end of the Radar Type 0 burst.</p> <p><b>Note 2:</b> The Channel Closing Transmission Time is comprised of 200 milliseconds starting at the beginning of the Channel Move Time plus any additional intermittent control signals required to facilitate a Channel move (an aggregate of 60 milliseconds) during the remainder of the 10 second period. The aggregate duration of control signals will not count quiet periods in between transmissions.</p> <p><b>Note 3:</b> During the U-NII Detection Bandwidth detection test, radar type 0 should be used. For each frequency step the minimum percentage of detection is 90 percent. Measurements are performed with no data traffic.</p>	

**Table 3-4: DFS Response Requirements**

FCC ID: ACJFZE1A		FCC Pt. 15.407 DFS TEST REPORT (CERTIFICATION)		Reviewed by: Quality Manager
Test Report S/N: 0Y1409171935.ACJ	Test Dates: 06/04-07/8/2014	EUT Type: Portable Handset	Page 7 of 15	

### 3.3 DFS Detection Threshold Values

The DFS detection thresholds are defined for Master devices and Client Devices with In-service monitoring. These detection thresholds are listed in the following table.

Maximum Transmit Power	Value (See Notes 1, 2, and 3)
EIRP $\geq$ 200 milliwatt	-64 dBm
EIRP < 200 milliwatt and power spectral density < 10 dBm/MHz	-62 dBm
EIRP < 200 milliwatt that do not meet the power spectral density requirement	-62 dBm
<p><b>Note 1:</b> This is the level at the input of the receiver assuming a 0 dBi receive antenna.</p> <p><b>Note 2:</b> Throughout these test procedures an additional 1 dB has been added to the amplitude of the test transmission waveforms to account for variations in measurement equipment. This will ensure that the test signal is at or above the detection threshold level to trigger a DFS response.</p> <p><b>Note3:</b> EIRP is based on the highest antenna gain. For MIMO devices refer to KDB Publication 662911 D01.</p>	



**Table 3-5: Detection Thresholds for Master Devices and Client Devices with Radar Detection**

### 3.4 Parameters of DFS Test Signals

As the EUT is a Client Device with no Radar Detection only one type radar pulse is required for the testing. Radar Pulse type 1 was used in the evaluation of the Client device for the purpose of measuring the Channel Move Time and the Channel Closing Transmission Time. Table 3-6 lists the parameters for the Short Pulse Radar Waveforms. A plot of the Radar Pulse Type 1 used for testing is included in Section 5.0 of this report.

Radar Type	Pulse Width ( $\mu$ sec)	PRI ( $\mu$ sec)	Number of Pulses	Minimum Percentage of Successful Detection	Minimum Number of Trials
0	1	1428	18	See Note 1	See Note 1
1	1	1428	18	60%	30
2	1-5	150-230	23-29	60%	30
3	6-10	200-500	16-18	60%	30
4	11-20	200-500	12-16	60%	30
Aggregate (Radar Types 1-4)				80%	120
<p><b>Note 1:</b> Short Pulse Radar Type 0 should be used for the detection bandwidth test, channel move time, and channel closing time tests.</p>					

**Table 3-6: Parameters for Short Pulse Radar Waveforms**

FCC ID: ACJFZE1A		FCC Pt. 15.407 DFS TEST REPORT (CERTIFICATION)		Reviewed by: Quality Manager
Test Report S/N: 0Y1409171935.ACJ	Test Dates: 06/04-07/8/2014	EUT Type: Portable Handset	Page 8 of 15	

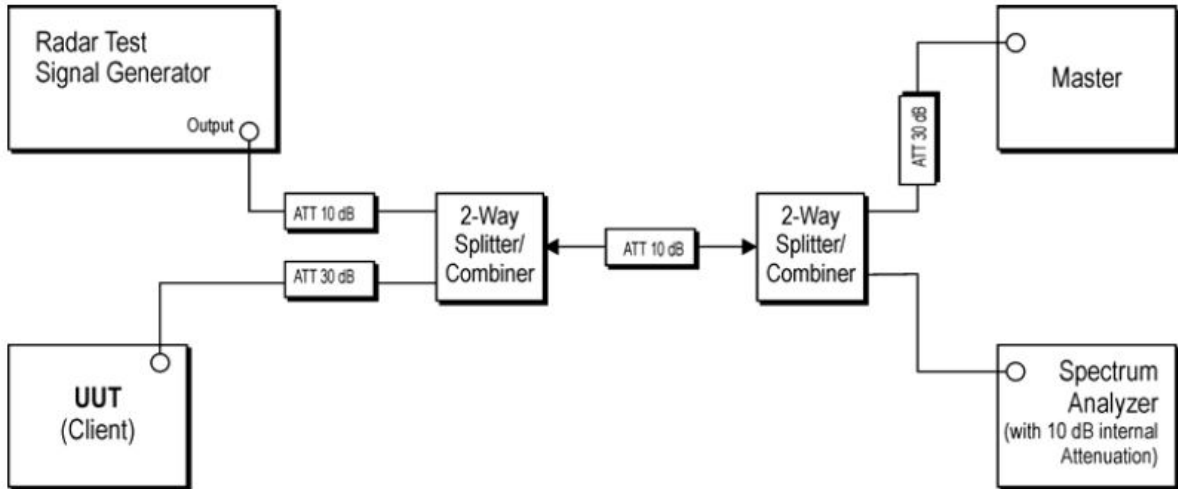

### 3.5 Procedure

Section 7 of KDB 905462 D02 v01 describes a radiated test setup and a conducted test setup. The conducted test setup was used for this testing. Figure 3-1 shows the typical test setup. In Band 2A, one channel selected between 5260 and 5350 MHz is chosen for the testing. In Band 2C, one channel selected between 5500 and 5700 MHz was chosen for testing. Per KDB 905462 D02 v01, the test was conducted using the widest BW mode available for the link.



**Figure 3-1. Conducted Test Setup for DFS**

1. The “Aeroflex PXI DFS Radar Simulator and Analyzer Test Suite” is setup to provide a simulated radar pulse at the frequency that the Master and Client are operating. A Type 0 radar pulse was used.
2. The Client Device (EUT) is set up per the diagram in Figure 3-1 and communications between the Master device and the Client is established.
3. The client is set to stream an MPEG video file that allows the client to meet the 17% minimum channel loading requirement specified in Section 7.7 of KDB 905462 D02 v01.
4. The “Aeroflex PXI DFS Radar Simulator and Analyzer Test Suite” is set to record and display 12 seconds of time, starting from where the simulated radar is generated. This time domain plot captures any transmissions occurring up to and after 10sec. Aggregate time is also computed per KDB 905462 D02 v01 to ensure compliance. (Note: the channel may be different since the Master and Client have changed channels due to the detection of the initial radar pulse.)
5. After the initial radar burst the channel is monitored for 30 minutes to ensure no transmissions or beacons occur. A second monitoring setup is used to verify that the Master and Client have both moved to different channels.

FCC ID: ACJFZE1A		FCC Pt. 15.407 DFS TEST REPORT (CERTIFICATION)		Reviewed by: Quality Manager
Test Report S/N: 0Y1409171935.ACJ	Test Dates: 06/04-07/8/2014	EUT Type: Portable Handset		Page 9 of 15

## 4.0 TEST EQUIPMENT

Test Equipment Calibration is traceable to the National Institute of Standards and Technology (NIST).

Manufacturer	Model	Description	Cal Date	Cal Interval	Cal Due	Serial Number
Aeroflex	PXI 82531	PXI DFS Radar Simulator & Analyzer	12/20/2013	Annual	12/20/2014	1082329
Agilent	E4448A	PSA (3Hz-50GHz) Spectrum Analyzer	4/16/2014	Annual	4/16/2015	US42510244
Seekonk	NC-100	Torque Wrench (8" lb)	4/16/2014	Biennial	4/16/2016	N/A



**Table 4-1. Annual Test Equipment Calibration Schedule**

### 4.1 Additional Equipment

The following equipment was used in support of the DFS testing.

Device	Manufacturer	Model/Description	Description	S/N:	FCC ID:
Master	Cisco Systems	Aironet AIR-AP1242AG-A-K9	Access Point	FTX1114B151	LDK102056

**Table 4-2. Support Equipment**

FCC ID: ACJFZE1A		FCC Pt. 15.407 DFS TEST REPORT (CERTIFICATION)		Reviewed by: Quality Manager
Test Report S/N: 0Y1409171935.ACJ	Test Dates: 06/04-07/8/2014	EUT Type: Portable Handset	Page 10 of 15	

## 5.0 TEST RESULTS

### Channel Loading Notes:

Per KDB 905462 D02 v01, timing plots are required with calculations demonstrating a minimum channel loading of approximately 17% or greater. For example, you can zero span the spectrum analyzer and approximate the transmission time.

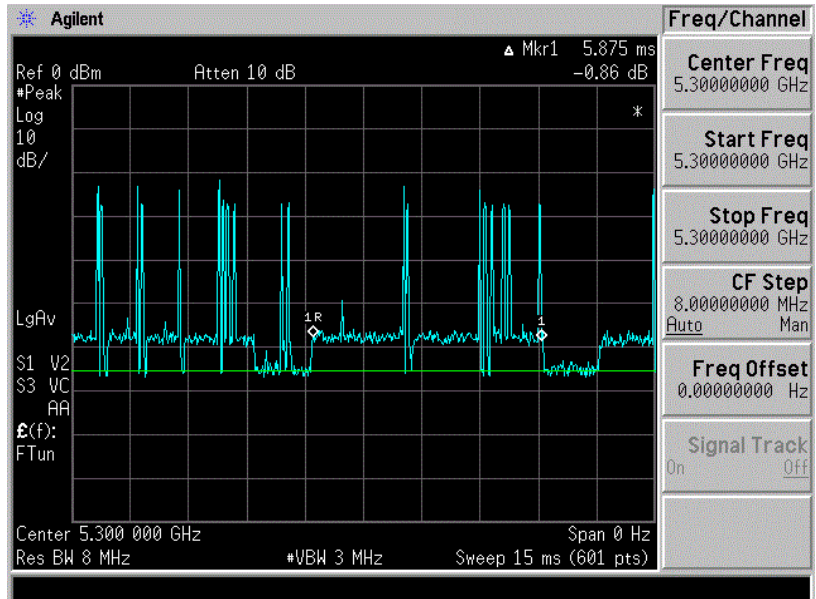

**Figure 5-1. Band 2A Pulse Width**

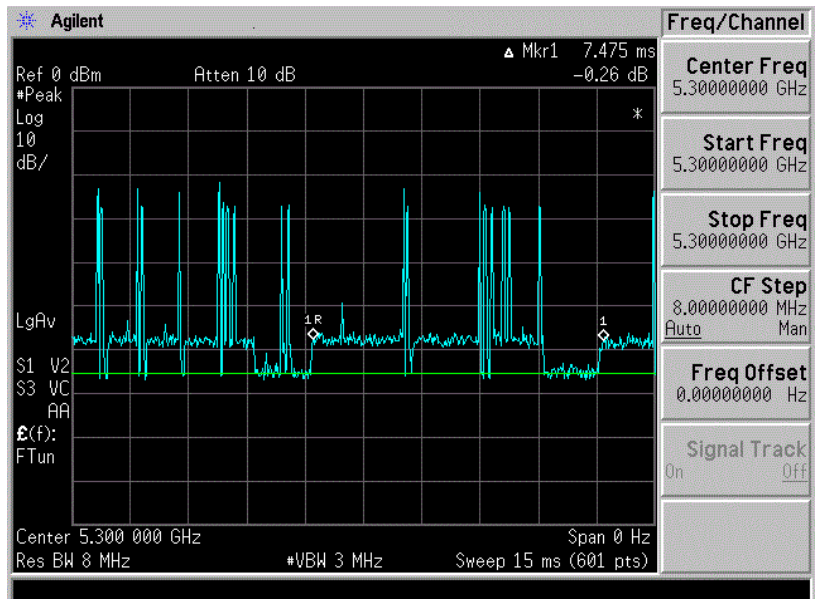

**Figure 5-2. Band 2A Period**

$$\text{Channel Loading} = \text{Pulse Width} / \text{Period} = 5.875 \text{ ms} / 7.475 \text{ ms} = 78.9 \%$$

FCC ID: ACJFZE1A		FCC Pt. 15.407 DFS TEST REPORT (CERTIFICATION)		Reviewed by: Quality Manager
Test Report S/N: 0Y1409171935.ACJ	Test Dates: 06/04-07/8/2014	EUT Type: Portable Handset		Page 11 of 15

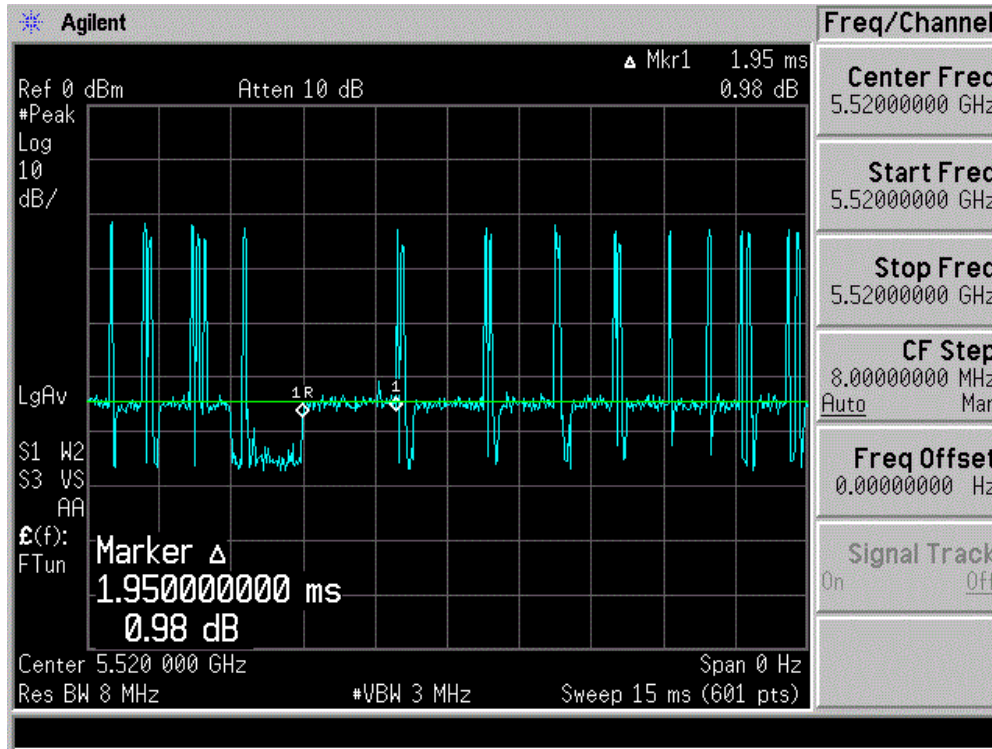

Figure 5-3. Band 2C Pulse Width

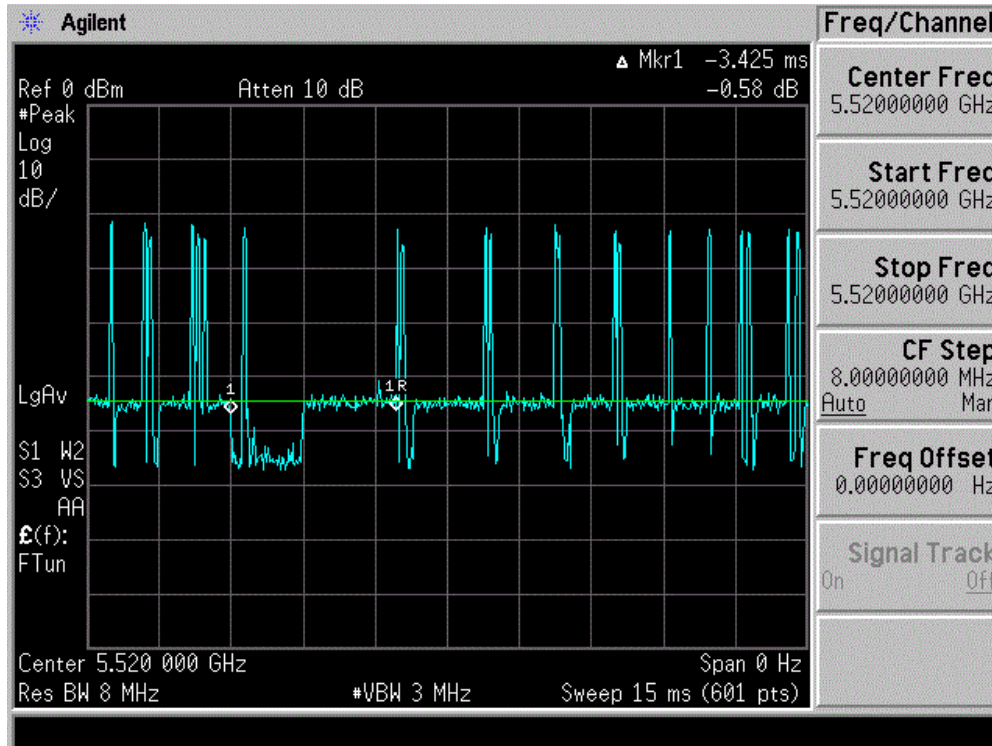



Figure 5-4. Band 2C Period

Channel Loading = Pulse Width / Period = 1.95 ms / 3.425 ms = 56.9 %

FCC ID: ACJFZE1A		FCC Pt. 15.407 DFS TEST REPORT (CERTIFICATION)		Reviewed by: Quality Manager
Test Report S/N: 0Y1409171935.ACJ	Test Dates: 06/04-07/8/2014	EUT Type: Portable Handset		Page 12 of 15

### Move Time and Aggregate Time Notes:

1. Trigger Threshold was configured to only capture client pulses. The pulses shown in the plots below have been determined to be from the Master AP.
2. Marker Info and Aggregate time results are shown on the right side of the plots below.

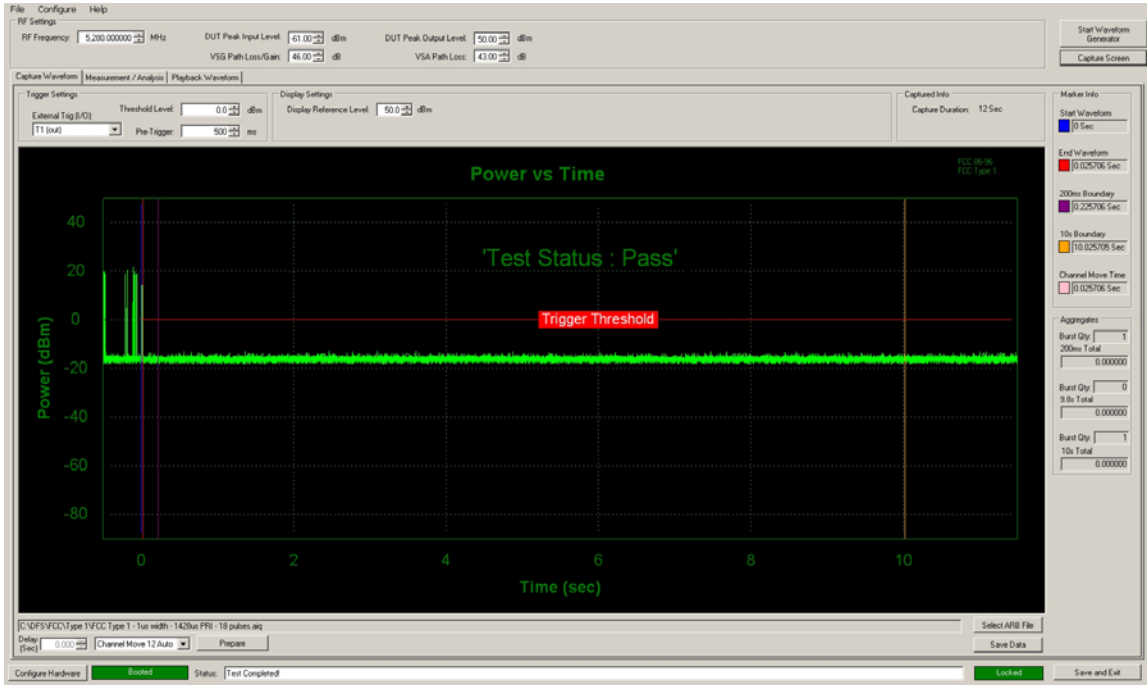

Figure 5-5. Band 2A Move Time and Aggregate Time

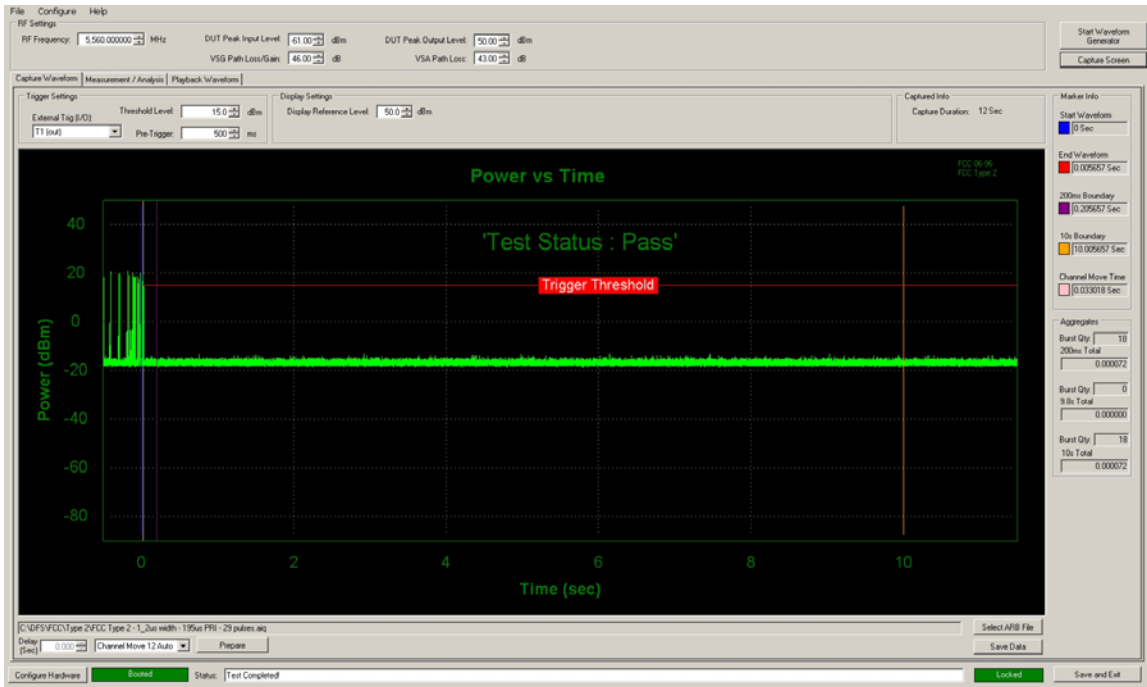
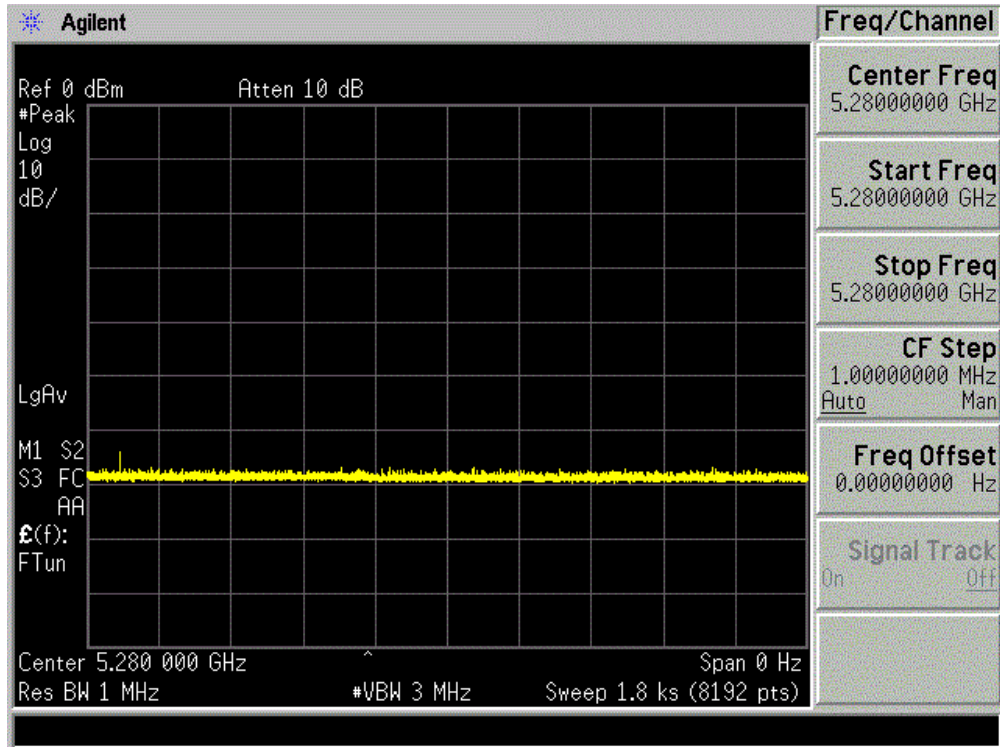
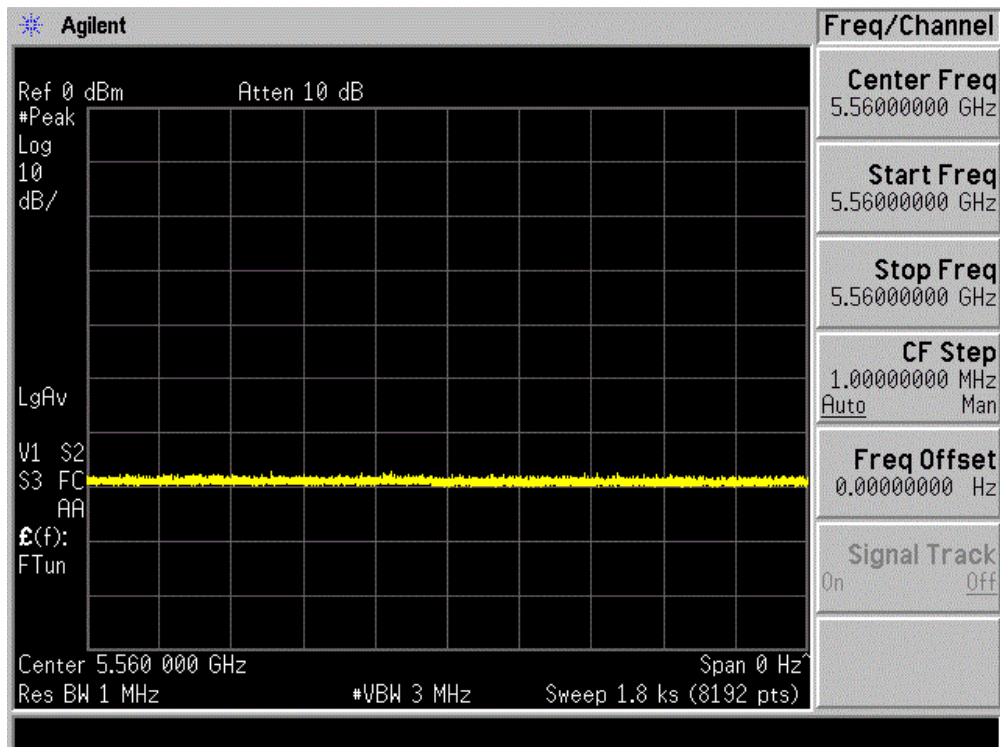

Figure 5-6. Band 2C Move Time and Aggregate Time



FCC ID: ACJFZE1A		FCC Pt. 15.407 DFS TEST REPORT (CERTIFICATION)		Reviewed by: Quality Manager
Test Report S/N: 0Y1409171935.ACJ	Test Dates: 06/04-07/8/2014	EUT Type: Portable Handset		Page 13 of 15



**Figure 5-7. Band 2A Non-occupancy Period - Monitoring live spectrum - Elapse time 30 minutes**





**Figure 5-8. Band 2C Non-occupancy Period - Monitoring live spectrum - Elapse time 30 minutes**

FCC ID: ACJFZE1A		FCC Pt. 15.407 DFS TEST REPORT (CERTIFICATION)		Reviewed by: Quality Manager
Test Report S/N: 0Y1409171935.ACJ	Test Dates: 06/04-07/8/2014	EUT Type: Portable Handset		Page 14 of 15

## 6.0 CONCLUSION

The data collected relate only to the item(s) tested and show that the **Panasonic Portable Handset FCC ID: ACJFZE1A** is in compliance with the DFS requirements for a Client Device without radar detection in accordance with Part 15.407 of the FCC Rules.

<b>FCC ID:</b> ACJFZE1A		<b>FCC Pt. 15.407 DFS TEST REPORT (CERTIFICATION)</b>		<b>Reviewed by:</b> Quality Manager
<b>Test Report S/N:</b> 0Y1409171935.ACJ	<b>Test Dates:</b> 06/04-07/8/2014	<b>EUT Type:</b> Portable Handset	Page 15 of 15	