



## SAR EVALUATION REPORT

**Applicant Name:**  
 Panasonic Corporation of North America  
 Two Riverfront Plaza, 9th Floor  
 Newark, NJ 07102  
 United States

**Date of Testing:**  
 10/28/15 - 11/03/15  
**Test Site/Location:**  
 PCTEST Lab, Columbia, MD, USA  
**Document Serial No.:**  
 0Y1510271888.ACJ

**FCC ID:** ACJEB3910A

**APPLICANT:** PANASONIC CORPORATION OF NORTH AMERICA

**DUT Type:** Portable Handset  
**Application Type:** Class II Permissive Change  
**FCC Rule Part(s):** CFR §2.1093  
**Model(s):** FZ-X1, FZ-X1V1  
**Permissive Change(s):** See FCC Change Document  
**Date of Original Certification:** 02/25/2014

| Equipment Class                                   | Band & Mode      | Tx Frequency        | SAR              |                       |                     |                        |
|---|------------------|---------------------|------------------|-----------------------|---------------------|------------------------|
|   |                  |                     | 1 gm Head (W/kg) | 1 gm Body-Worn (W/kg) | 1 gm Hotspot (W/kg) | 10 gm Extremity (W/kg) |
| PCE   | LTE Band 4 (AWS) | 1712.5 - 1752.5 MHz | 0.56             | 0.28                  | 0.69                | 0.29                   |
| <b>Simultaneous SAR per KDB 690783 D01v01r03:</b> |                  |                     | 0.61             | 0.49                  | 0.87                | 0.46                   |

Note: The table above shows LTE Band 4 SAR Test Data evaluated for the current test report. Please refer to RF Exposure Technical Report S/N 0Y1312092376-R1.ACJ for original compliance evaluation.



This wireless portable device has been shown to be capable of compliance for localized specific absorption rate (SAR) for uncontrolled environment/general population exposure limits specified in ANSI/IEEE C95.1-1992 and has been tested in accordance with the measurement procedures specified in Section 1.9 of this report; for North American frequency bands only.

I attest to the accuracy of data. All measurements reported herein were performed by me or were made under my supervision and are correct to the best of my knowledge and belief. I assume full responsibility for the completeness of these measurements and vouch for the qualifications of all persons taking them. Test results reported herein relate only to the item(s) tested.

  
 Randy Ortanez  
 President





The SAR Tick is an initiative of the Mobile Manufacturers Forum (MMF). While a product may be considered eligible, use of the SAR Tick logo requires an agreement with the MMF. Further details can be obtained by emailing: [sartick@mmfai.info](mailto:sartick@mmfai.info).

|                                   |   |                               |   |                                 |
|-----------------------------------|---|-------------------------------|---|---------------------------------|
| FCC ID: ACJEB3910A                |  PCTEST ENGINEERING LABORATORY, INC. | SAR EVALUATION REPORT         |  | Reviewed by:<br>Quality Manager |
| Document S/N:<br>0Y1510271888.ACJ | Test Dates:<br>10/28/15 - 11/03/15  | DUT Type:<br>Portable Handset |   | Page 1 of 31                    |

# T A B L E O F C O N T E N T S

|             |  |    |
|-------------|--|----|
| 1           | DEVICE UNDER TEST .....                          | 3  |
| 2           | LTE INFORMATION .....                            | 7  |
| 3           | INTRODUCTION .....                               | 8  |
| 4           | DOSIMETRIC ASSESSMENT .....                      | 9  |
| 5           | DEFINITION OF REFERENCE POINTS .....             | 10 |
| 6           | TEST CONFIGURATION POSITIONS FOR HANDSETS .....  | 11 |
| 7           | RF EXPOSURE LIMITS .....                         | 14 |
| 8           | FCC MEASUREMENT PROCEDURES.....                  | 15 |
| 9           | RF CONDUCTED POWERS.....                         | 17 |
| 10          | SYSTEM VERIFICATION.....                         | 21 |
| 11          | SAR DATA SUMMARY .....                           | 22 |
| 12          | FCC MULTI-TX AND ANTENNA SAR CONSIDERATIONS..... | 24 |
| 13          | SAR MEASUREMENT VARIABILITY .....                | 26 |
| 14          | EQUIPMENT LIST.....                              | 27 |
| 15          | MEASUREMENT UNCERTAINTIES .....                  | 28 |
| 16          | CONCLUSION.....                                  | 29 |
| 17          | REFERENCES .....                                 | 30 |
|             |  |    |
| APPENDIX A: | SAR TEST PLOTS                                   |    |
| APPENDIX B: | SAR DIPOLE VERIFICATION PLOTS                    |    |
| APPENDIX C: | PROBE AND DIPOLE CALIBRATION CERTIFICATES        |    |
| APPENDIX D: | SAR TISSUE SPECIFICATIONS                        |    |
| APPENDIX E: | SAR SYSTEM VALIDATION                            |    |
| APPENDIX F: | DUT ANTENNA DIAGRAM & SAR TEST SETUP PHOTOGRAPHS |    |

|                                   |   |                               |   |                                 |
|-----------------------------------|---|-------------------------------|---|---------------------------------|
| FCC ID: ACJEB3910A                |  | SAR EVALUATION REPORT         |  | Reviewed by:<br>Quality Manager |
| Document S/N:<br>0Y1510271888.ACJ | Test Dates:<br>10/28/15 - 11/03/15  | DUT Type:<br>Portable Handset | Page 2 of 31  |                                 |

# 1 DEVICE UNDER TEST

## 1.1 Device Overview

| Band & Mode        | Operating Modes | Tx Frequency          |
|--------------------|-----------------|-----------------------|
| GSM/GPRS/EDGE 850  | Voice/Data      | 824.20 - 848.80 MHz   |
| GSM/GPRS/EDGE 1900 | Voice/Data      | 1850.20 - 1909.80 MHz |
| UMTS 850           | Voice/Data      | 826.40 - 846.60 MHz   |
| UMTS 1900          | Voice/Data      | 1852.4 - 1907.6 MHz   |
| Cell. CDMA/EVDO    | Voice/Data      | 824.70 - 848.31 MHz   |
| PCS CDMA/EVDO      | Voice/Data      | 1851.25 - 1908.75 MHz |
| LTE Band 17        | Data            | 706.5 - 713.5 MHz     |
| LTE Band 13        | Data            | 782 MHz               |
| LTE Band 4 (AWS)   | Data            | 1712.5 - 1752.5 MHz   |
| 2.4 GHz WLAN       | Data            | 2412 - 2462 MHz       |
| U-NII-1            | Data            | 5180 - 5240 MHz       |
| U-NII-2A           | Data            | 5260 - 5320 MHz       |
| U-NII-2C           | Data            | 5500 - 5700 MHz       |
| U-NII-3            | Data            | 5745 - 5825 MHz       |
| Bluetooth          | Data            | 2402 - 2480 MHz       |
| NFC                | Data            | 13.56 MHz             |

## 1.2 Nominal and Maximum Output Power Specifications

This device operates using the following maximum and nominal output power specifications. SAR values were scaled to the maximum allowed power to determine compliance per KDB Publication 447498 D01v05r02.

| Mode / Band      |         | Modulated Average (dBm) |
|------------------|---------|-------------------------|
| LTE Band 4 (AWS) | Maximum | <b>23.9</b>             |
|                  | Nominal | <b>23.0</b>             |



## 1.3 DUT Antenna Locations

The overall dimensions of this device are  $\geq 9 \times 5$  cm. A diagram showing the location of the device antennas can be found in Appendix F. Since the diagonal dimension of this device is  $> 160$  mm and  $< 200$  mm, it is considered a "phablet."

**Table 1-1  
Device Edges/Sides for SAR Testing**

| Mode             | Back | Front | Top | Bottom | Right | Left |
|------------------|------|-------|-----|--------|-------|------|
| LTE Band 4 (AWS) | Yes  | Yes   | No  | Yes    | Yes   | Yes  |

Note: Particular DUT edges were not required to be evaluated for wireless router SAR or Extremity SAR if the edges were greater than 2.5 cm from the transmitting antenna according to FCC KDB Publication 941225 D06v02 guidance, page 2 and FCC KDB 648474 D04v01r02. The distances between the transmit antennas and the edges of the device are included in the filing.

|                                   |  |                               |   |                                 |
|-----------------------------------|--|-------------------------------|---|---------------------------------|
| FCC ID: ACJEB3910A                |  PCTEST<br>ENGINEERING LABORATORY, INC. | SAR EVALUATION REPORT         |  Panasonic | Reviewed by:<br>Quality Manager |
| Document S/N:<br>0Y1510271888.ACJ | Test Dates:<br>10/28/15 - 11/03/15   | DUT Type:<br>Portable Handset |   | Page 3 of 31                    |

## 1.4 Near Field Communications (NFC) Antenna

This DUT has NFC operations. The NFC antenna is integrated into the device. Therefore, all SAR tests were performed with the NFC antenna already incorporated. A diagram showing the location of the NFC antenna can be found in Appendix F.

## 1.5 Simultaneous Transmission Capabilities

According to FCC KDB Publication 447498 D01v05r02, transmitters are considered to be transmitting simultaneously when there is overlapping transmission, with the exception of transmissions during network hand-offs with maximum hand-off duration less than 30 seconds. Possible transmission paths for the DUT are shown in Figure 1-1 and are color-coded to indicate communication modes which share the same path. Modes which share the same transmission path cannot transmit simultaneously with one another.



**Figure 1-1**  
**Simultaneous Transmission Paths**

This device contains multiple transmitters that may operate simultaneously, and therefore requires a simultaneous transmission analysis according to FCC KDB Publication 447498 D01v05 3) procedures.

**Table 1-2**  
**Simultaneous Transmission Scenarios**

| No. | Capable Transmit Configuration          | Head | Body-Worn Accessory | Wireless Router | Extremity | Notes   |
|-----|---|------|---------------------|-----------------|-----------|---|
| 1   | 1x CDMA voice + 2.4 GHz WI-FI           | Yes  | Yes                 | N/A             | Yes       |   |
| 2   | 1x CDMA voice + 5 GHz WI-FI             | Yes  | Yes                 | N/A             | Yes       |   |
| 3   | 1x CDMA voice + 2.4 GHz Bluetooth       | N/A  | Yes                 | N/A             | Yes       |   |
| 4   | GSM voice + 2.4 GHz WI-FI               | Yes  | Yes                 | N/A             | Yes       |   |
| 5   | GSM voice + 5 GHz WI-FI                 | Yes  | Yes                 | N/A             | Yes       |   |
| 6   | GSM voice + 2.4 GHz Bluetooth           | N/A  | Yes                 | N/A             | Yes       |   |
| 7   | UMTS + 2.4 GHz WI-FI                    | Yes  | Yes                 | Yes             | Yes       |   |
| 8   | UMTS + 5 GHz WI-FI                      | Yes  | Yes                 | N/A             | Yes       |   |
| 9   | UMTS + 2.4 GHz Bluetooth                | N/A  | Yes                 | N/A             | Yes       |   |
| 10  | LTE + 2.4 GHz WI-FI                     | Yes* | Yes*                | Yes             | Yes       | *-Pre-installed VOIP applications are considered. |
| 11  | LTE + 2.4 GHz Bluetooth                 | N/A  | Yes*                | N/A             | Yes       | *-Pre-installed VOIP applications are considered. |
| 12  | CDMA/EVDO data + 2.4 GHz WI-FI          | Yes* | Yes*                | Yes             | Yes       | *-Pre-installed VOIP applications are considered. |
| 13  | CDMA/EVDO data + 2.4 GHz Bluetooth      | N/A  | Yes*                | N/A             | Yes       | *-Pre-installed VOIP applications are considered. |
| 14  | GPRS/EDGE + 2.4 GHz WI-FI               | Yes* | Yes*                | Yes             | Yes       | *-Pre-installed VOIP applications are considered. |
| 15  | GPRS/EDGE + 2.4 GHz Bluetooth           | N/A  | Yes*                | N/A             | Yes       | *-Pre-installed VOIP applications are considered. |
| 16  | LTE + 5 GHz WI-FI                       | N/A  | N/A                 | N/A             | N/A       | Not supported by SW                               |
| 17  | CDMA/EVDO data + 5 GHz WI-FI            | N/A  | N/A                 | N/A             | N/A       | Not supported by SW                               |
| 18  | GPRS/EDGE + 5 GHz WI-FI                 | N/A  | N/A                 | N/A             | N/A       | Not supported by SW                               |
| 19  | 1x CDMA voice + CDMA/EVDO data          | N/A  | N/A                 | N/A             | N/A       | Not supported by HW                               |
| 20  | CDMA/EVDO data + LTE                    | N/A  | N/A                 | N/A             | N/A       | Not supported by HW                               |
| 21  | 1x CDMA voice + LTE                     | N/A  | N/A                 | N/A             | N/A       | Not supported by HW                               |
| 22  | 1x CDMA voice + LTE + 2.4 GHz WI-FI     | N/A  | N/A                 | N/A             | N/A       | Not supported by HW                               |
| 23  | 1x CDMA voice + LTE + 5 GHz WI-FI       | N/A  | N/A                 | N/A             | N/A       | Not supported by HW                               |
| 24  | 1x CDMA voice + LTE + 2.4 GHz Bluetooth | N/A  | N/A                 | N/A             | N/A       | Not supported by HW                               |

### Notes:

- 2.4 GHz WLAN, 2.4 GHz Bluetooth and 5 GHz WLAN share the same antenna path and cannot transmit simultaneously.
- GPRS/EDGE/UMTS/CDMA/EVDO/LTE share the same antenna path and cannot transmit simultaneously.
- WIFI Direct is supported for 2.4 GHz only. Therefore, there are no simultaneous transmission scenarios involving WIFI direct beyond that listed in the above table.

|                                   |  |                               |           |                                 |
|-----------------------------------|--|-------------------------------|-----------|---------------------------------|
| FCC ID: ACJEB3910A                | PCTEST<br>ENGINEERING LABORATORY, INC. | SAR EVALUATION REPORT         | Panasonic | Reviewed by:<br>Quality Manager |
| Document S/N:<br>0Y1510271888.ACJ | Test Dates:<br>10/28/15 - 11/03/15     | DUT Type:<br>Portable Handset |           | Page 4 of 31                    |

## 1.6 Body Holster and Hand Strap Device Accessories

This DUT may also be used with two accessories containing metallic components: a body holster and a hand strap. Per FCC KDB Publication 447498 D01 v05r01, the accessories were tested in conjunction with the host device to demonstrate compliance. The belt holster was evaluated as a body-worn accessory with front and back side evaluated for 1g body-worn SAR with the belt holster for each wireless technology and frequency band at 0mm from the phantom. The hand strap accessory was evaluated for compliance by measuring back side 10g extremity SAR at 0mm for each wireless technology and frequency band. Two diagonal configurations of the metallic components are possible when attaching the hand strap to the device and both were considered in the SAR evaluation. They are referred to as “Hand Strap, Top Right” and “Hand Strap, Top Left.” Please see Figure 1-2 for clarification of the location of the metallic components in these configurations.

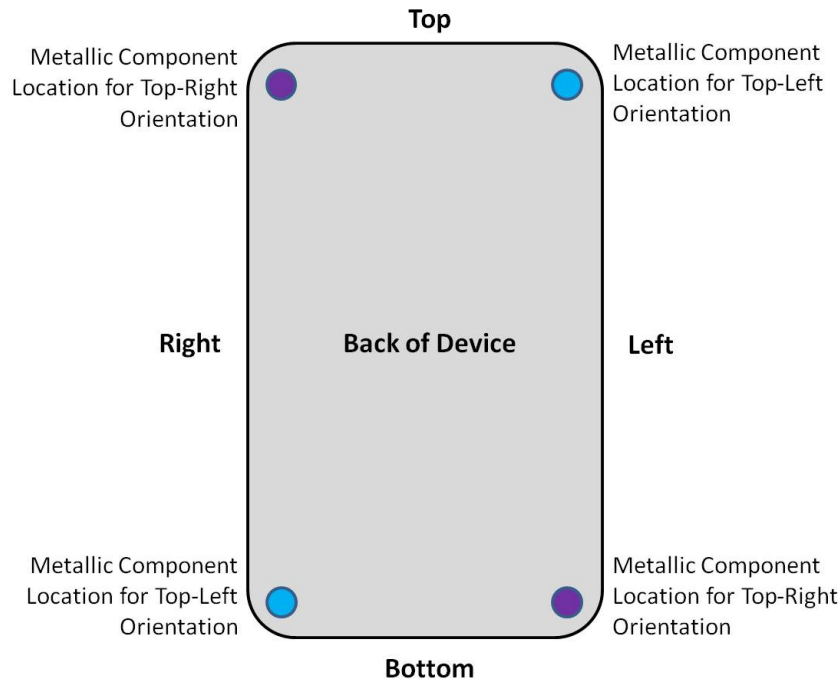



**Figure 1-2**  
**Hand Strap Metallic Component Locations**

## 1.7 Miscellaneous SAR Test Considerations

This report evaluates SAR compliance for LTE Band 4. Please refer to RF Exposure Technical Reports 0Y1312092376-R1.ACJ for original compliance reports containing data for other main antenna and WLAN modes. No changes were made to any other mode or band.

### (A) Licensed Transmitter(s)

LTE SAR for the higher modulations and lower bandwidths were not tested since the maximum average output power of all required channels and configurations was not more than 0.5 dB higher than the highest bandwidth; and the reported LTE SAR for the highest bandwidth was less than 1.45 W/kg for all configurations according to FCC KDB 941225 D05v02r03.

|                                   |   |                               |   |                                 |
|-----------------------------------|---|-------------------------------|---|---------------------------------|
| FCC ID: ACJEB3910A                |  | SAR EVALUATION REPORT         |  | Reviewed by:<br>Quality Manager |
| Document S/N:<br>0Y1510271888.ACJ | Test Dates:<br>10/28/15 - 11/03/15  | DUT Type:<br>Portable Handset |   | Page 5 of 31                    |

Per FCC KDB Publication 648474 D04v01r02, this device is considered a "phablet" since the diagonal dimension is greater than 160mm and less than 200mm. Therefore, phablet SAR tests are required when wireless router mode does not apply or if wireless router 1g SAR > 1.2 W/kg. Extremity SAR was not evaluated for licensed technologies since wireless router 1g SAR was < 1.2 W/kg for these modes.

## 1.8 Power Reduction for SAR

There is no power reduction used for any band/mode implemented in this device for SAR purposes.



## 1.9 Guidance Applied

- IEEE 1528-2003
- FCC KDB Publication 941225 D05v02r03, D06v02 (4G and Hotspot)
- FCC KDB Publication 248227 D01v02r01 (SAR Considerations for 802.11 Devices)
- FCC KDB Publication 447498 D01v05r02 (General SAR Guidance)
- FCC KDB Publication 865664 D01v01r04, D02v01r01 (SAR Measurements up to 6 GHz)
- FCC KDB Publication 648474 D04v01r02 (Phablet Procedures)

## 1.10 Device Serial Numbers

Several samples with identical hardware were used to support SAR testing. The manufacturer has confirmed that the device(s) tested have the same physical, mechanical and thermal characteristics and are within operational tolerances expected for production units.



|                  | Head Serial Number | Body-Worn Serial Number | Hotspot Serial Number | Extremity Serial Number |
|------------------|--------------------|-------------------------|-----------------------|-------------------------|
| LTE Band 4 (AWS) | 22046              | 22046                   | 22046                 | 22046                   |

|  |   |                                      |   |  |
|--|---|--------------------------------------|---|--|
| FCC ID: ACJEB3910A                       |  <b>PCTEST</b><br>ENGINEERING LABORATORY, INC. | <b>SAR EVALUATION REPORT</b>         |  | <b>Reviewed by:</b><br>Quality Manager |
| <b>Document S/N:</b><br>0Y1510271888.ACJ | <b>Test Dates:</b><br>10/28/15 - 11/03/15   | <b>DUT Type:</b><br>Portable Handset |   | Page 6 of 31                           |

## 2

## LTE INFORMATION

| LTE Information   |   |                |                |
|---|---|----------------|----------------|
| FCC ID  | ACJEB3910A                                      |                |                |
| Form Factor   | Portable Handset                                |                |                |
| Frequency Range of each LTE transmission band   | LTE Band 17 (706.5 - 713.5 MHz)                 |                |                |
|   | LTE Band 13 (782 - 782 MHz)                     |                |                |
|   | LTE Band 4 (AWS) (1712.5 - 1752.5 MHz)          |                |                |
| Channel Bandwidths  | LTE Band 17: 5 MHz, 10 MHz                      |                |                |
|   | LTE Band 13: 10 MHz                             |                |                |
|   | LTE Band 4 (AWS): 5 MHz, 10 MHz, 15 MHz, 20 MHz |                |                |
| Channel Numbers and Frequencies (MHz)   | Low   | Mid            | High           |
| LTE Band 17: 5 MHz  | 706.5 (23755)                                   | 710 (23790)    | 713.5 (23825)  |
| LTE Band 17: 10 MHz   | 709 (23780)                                     | 710 (23790)    | 711 (23800)    |
| LTE Band 13: 10 MHz   | N/A   | 782 (23230)    | N/A            |
| LTE Band 4 (AWS): 5 MHz   | 1712.5 (19975)                                  | 1732.5 (20175) | 1752.5 (20375) |
| LTE Band 4 (AWS): 10 MHz  | 1715 (20000)                                    | 1732.5 (20175) | 1750 (20350)   |
| LTE Band 4 (AWS): 15 MHz  | 1717.5 (20025)                                  | 1732.5 (20175) | 1747.5 (20325) |
| LTE Band 4 (AWS): 20 MHz  | 1720 (20050)                                    | 1732.5 (20175) | 1745 (20300)   |
| UE Category   | 3   |                |                |
| Modulations Supported in UL   | QPSK, 16QAM                                     |                |                |
| LTE MPR Permanently implemented per 3GPP TS 36.101 section 6.2.3~6.2.5? (manufacturer attestation to be provided) | YES   |                |                |
| A-MPR (Additional MPR) disabled for SAR Testing?  | YES   |                |                |

|                                   |   |                               |   |                                 |
|-----------------------------------|---|-------------------------------|---|---------------------------------|
| FCC ID: ACJEB3910A                |  | SAR EVALUATION REPORT         |  | Reviewed by:<br>Quality Manager |
| Document S/N:<br>0Y1510271888.ACJ | Test Dates:<br>10/28/15 - 11/03/15  | DUT Type:<br>Portable Handset |   | Page 7 of 31                    |

## 3 INTRODUCTION

The FCC and Industry Canada have adopted the guidelines for evaluating the environmental effects of radio frequency (RF) radiation in ET Docket 93-62 on Aug. 6, 1996 and Health Canada Safety Code 6 to protect the public and workers from the potential hazards of RF emissions due to FCC-regulated portable devices. [1]

The safety limits used for the environmental evaluation measurements are based on the criteria published by the American National Standards Institute (ANSI) for localized specific absorption rate (SAR) in IEEE/ANSI C95.1-1992 Standard for Safety Levels with Respect to Human Exposure to Radio Frequency Electromagnetic Fields, 3 kHz to 300 GHz [3] and Health Canada RF Exposure Guidelines Safety Code 6 [22]. The measurement procedure described in IEEE/ANSI C95.3-2002 Recommended Practice for the Measurement of Potentially Hazardous Electromagnetic Fields - RF and Microwave [4] is used for guidance in measuring the Specific Absorption Rate (SAR) due to the RF radiation exposure from the Equipment Under Test (EUT). These criteria for SAR evaluation are similar to those recommended by the International Committee for Non-Ionizing Radiation Protection (ICNIRP) in Biological Effects and Exposure Criteria for Radiofrequency Electromagnetic Fields,” Report No. Vol 74. SAR is a measure of the rate of energy absorption due to exposure to an RF transmitting source. SAR values have been related to threshold levels for potential biological hazards.

### 3.1 SAR Definition

Specific Absorption Rate is defined as the time derivative (rate) of the incremental energy (dU) absorbed by (dissipated in) an incremental mass (dm) contained in a volume element (dV) of a given density (ρ). It is also defined as the rate of RF energy absorption per unit mass at a point in an absorbing body (see Equation 3-1).

**Equation 3-1**  
**SAR Mathematical Equation**

$$SAR = \frac{d}{dt} \left( \frac{dU}{dm} \right) = \frac{d}{dt} \left( \frac{dU}{\rho dv} \right)$$



**SAR is expressed in units of Watts per Kilogram (W/kg).**

$$SAR = \frac{\sigma \cdot E^2}{\rho}$$

where:

- σ = conductivity of the tissue-simulating material (S/m)
- ρ = mass density of the tissue-simulating material (kg/m<sup>3</sup>)
- E = Total RMS electric field strength (V/m)

NOTE: The primary factors that control rate of energy absorption were found to be the wavelength of the incident field in relation to the dimensions and geometry of the irradiated organism, the orientation of the organism in relation to the polarity of field vectors, the presence of reflecting surfaces, and whether conductive contact is made by the organism with a ground plane.[6]

|                                   |   |                               |   |                                 |
|-----------------------------------|---|-------------------------------|---|---------------------------------|
| FCC ID: ACJEB3910A                |  | SAR EVALUATION REPORT         |  | Reviewed by:<br>Quality Manager |
| Document S/N:<br>0Y1510271888.ACJ | Test Dates:<br>10/28/15 - 11/03/15  | DUT Type:<br>Portable Handset | Page 8 of 31  |                                 |

# 4 DOSIMETRIC ASSESSMENT

## 4.1 Measurement Procedure

The evaluation was performed using the following procedure compliant to FCC KDB Publication 865664 D01v01r04 and IEEE 1528-2013:

1. The SAR distribution at the exposed side of the head or body was measured at a distance no greater than 5.0 mm from the inner surface of the shell. The area covered the entire dimension of the device-head and body interface and the horizontal grid resolution was determined per FCC KDB Publication 865664 D01v01r04 (See Table 4-1) and IEEE 1528-2013.
2. The point SAR measurement was taken at the maximum SAR region determined from Step 1 to enable the monitoring of SAR fluctuations/drifts during the 1g/10g cube evaluation. SAR at this fixed point was measured and used as a reference value.
3. Based on the area scan data, the peak of the region with maximum SAR was determined by spline interpolation. Around this point, a volume was assessed according to the measurement resolution and volume size requirements of FCC KDB Publication 865664 D01v01r04 (See Table 4-1) and IEEE 1528-2013. On the basis of this data set, the spatial peak SAR value was evaluated with the following procedure (see references or the DASY manual online for more details):
  - a. SAR values at the inner surface of the phantom are extrapolated from the measured values along the line away from the surface with spacing no greater than that in Table 4-1. The extrapolation was based on a least-squares algorithm. A polynomial of the fourth order was calculated through the points in the z-axis (normal to the phantom shell).
  - b. After the maximum interpolated values were calculated between the points in the cube, the SAR was averaged over the spatial volume (1g or 10g) using a 3D-Spline interpolation algorithm. The 3D-spline is composed of three one-dimensional splines with the “Not a knot” condition (in x, y, and z directions). The volume was then integrated with the trapezoidal algorithm. One thousand points (10 x 10 x 10) were obtained through interpolation, in order to calculate the averaged SAR.
  - c. All neighboring volumes were evaluated until no neighboring volume with a higher average value was found.
4. The SAR reference value, at the same location as step 2, was re-measured after the zoom scan was complete to calculate the SAR drift. If the drift deviated by more than 5%, the SAR test and drift measurements were repeated.

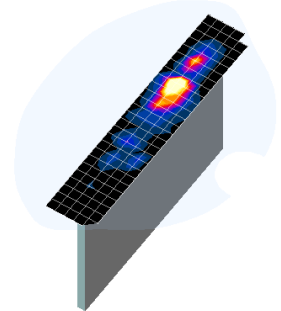



**Figure 4-1**  
Sample SAR Area Scan

**Table 4-1**  
Area and Zoom Scan Resolutions per FCC KDB Publication 865664 D01v01r04\*

| Frequency | Maximum Area Scan Resolution (mm) ( $\Delta x_{area}, \Delta y_{area}$ ) | Maximum Zoom Scan Resolution (mm) ( $\Delta x_{zoom}, \Delta y_{zoom}$ ) | Maximum Zoom Scan Spatial Resolution (mm) |                        |                               | Minimum Zoom Scan Volume (mm) (x,y,z) |
|-----------|--|--|---|------------------------|-------------------------------|---------------------------------------|
|           |  |  | Uniform Grid                              |                        | Graded Grid                   |                                       |
|           |  |  | $\Delta z_{zoom}(n)$                      | $\Delta z_{zoom}(1)^*$ | $\Delta z_{zoom}(n>1)^*$      |                                       |
| ≤ 2 GHz   | ≤ 15   | ≤ 8  | ≤ 5                                       | ≤ 4                    | ≤ 1.5* $\Delta z_{zoom}(n-1)$ | ≥ 30                                  |
| 2-3 GHz   | ≤ 12   | ≤ 5  | ≤ 5                                       | ≤ 4                    | ≤ 1.5* $\Delta z_{zoom}(n-1)$ | ≥ 30                                  |
| 3-4 GHz   | ≤ 12   | ≤ 5  | ≤ 4                                       | ≤ 3                    | ≤ 1.5* $\Delta z_{zoom}(n-1)$ | ≥ 28                                  |
| 4-5 GHz   | ≤ 10   | ≤ 4  | ≤ 3                                       | ≤ 2.5                  | ≤ 1.5* $\Delta z_{zoom}(n-1)$ | ≥ 25                                  |
| 5-6 GHz   | ≤ 10   | ≤ 4  | ≤ 2                                       | ≤ 2                    | ≤ 1.5* $\Delta z_{zoom}(n-1)$ | ≥ 22                                  |

\*Also compliant to IEEE 1528-2013 Table 6

|  |   |                                      |   |  |
|--|---|--------------------------------------|---|--|
| FCC ID: ACJEB3910A                       |  <b>PCTEST</b><br>ENGINEERING LABORATORY, INC. | <b>SAR EVALUATION REPORT</b>         |  | <b>Reviewed by:</b><br>Quality Manager |
| <b>Document S/N:</b><br>0Y1510271888.ACJ | <b>Test Dates:</b><br>10/28/15 - 11/03/15   | <b>DUT Type:</b><br>Portable Handset |   | Page 9 of 31                           |

# 5

# DEFINITION OF REFERENCE POINTS

## 5.1 EAR REFERENCE POINT

Figure 5-2 shows the front, back and side views of the SAM Twin Phantom. The point “M” is the reference point for the center of the mouth, “LE” is the left ear reference point (ERP), and “RE” is the right ERP. The ERP is 15mm posterior to the entrance to the ear canal (EEC) along the B-M line (Back-Mouth), as shown in Figure 5-1. The plane passing through the two ear canals and M is defined as the Reference Plane. The line N-F (Neck-Front), also called the Reference Pivoting Line, is not perpendicular to the reference plane (see Figure 5-1). Line B-M is perpendicular to the N-F line. Both N-F and B-M lines are marked on the external phantom shell to facilitate handset positioning [5].

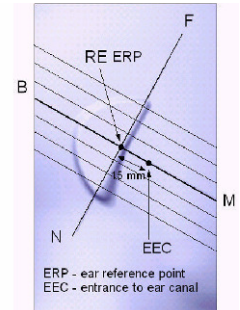

**Figure 5-1**  
Close-Up Side view of ERP

## 5.2 HANDSET REFERENCE POINTS

Two imaginary lines on the handset were established: the vertical centerline and the horizontal line. The test device was placed in a normal operating position with the acoustic output located along the “vertical centerline” on the front of the device aligned to the “ear reference point” (See Figure 5-3). The acoustic output was then located at the same level as the center of the ear reference point. The test device was positioned so that the “vertical centerline” was bisecting the front surface of the handset at its top and bottom edges, positioning the “ear reference point” on the outer surface of the both the left and right head phantoms on the ear reference point.

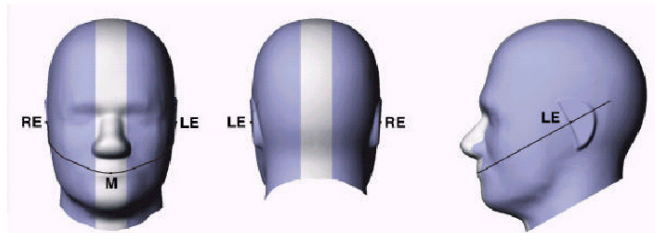

**Figure 5-2**  
Front, back and side view of SAM Twin Phantom

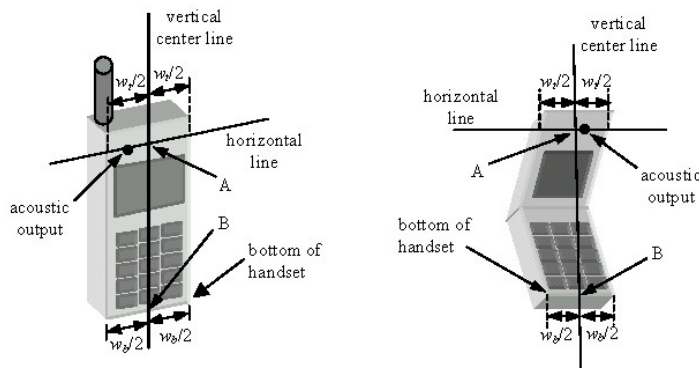

**Figure 5-3**  
Handset Vertical Center & Horizontal Line Reference Points

|                                   |  |                               |           |                                 |
|-----------------------------------|--|-------------------------------|-----------|---------------------------------|
| FCC ID: ACJEB3910A                | PCTEST<br>ENGINEERING LABORATORY, INC. | SAR EVALUATION REPORT         | Panasonic | Reviewed by:<br>Quality Manager |
| Document S/N:<br>0Y1510271888.ACJ | Test Dates:<br>10/28/15 - 11/03/15     | DUT Type:<br>Portable Handset |           | Page 10 of 31                   |

## 6 TEST CONFIGURATION POSITIONS FOR HANDSETS

### 6.1 Device Holder

The device holder is made out of low-loss POM material having the following dielectric parameters: relative permittivity  $\epsilon = 3$  and loss tangent  $\delta = 0.02$ .

### 6.2 Positioning for Cheek

1. The test device was positioned with the device close to the surface of the phantom such that point A is on the (virtual) extension of the line passing through points RE and LE on the phantom (see Figure 6-1), such that the plane defined by the vertical center line and the horizontal line of the phone is approximately parallel to the sagittal plane of the phantom.

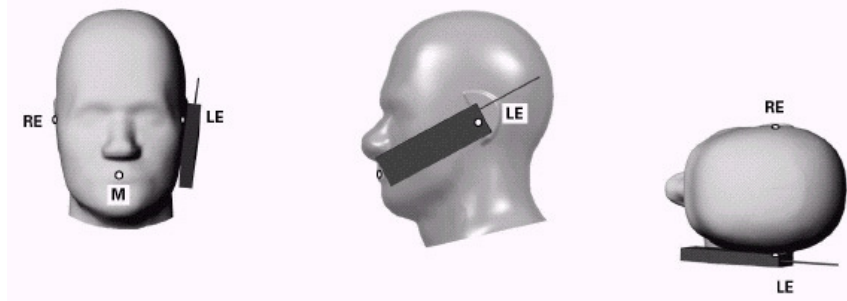



Figure 6-1 Front, Side and Top View of Cheek Position

2. The handset was translated towards the phantom along the line passing through RE & LE until the handset touches the pinna.
3. While maintaining the handset in this plane, the handset was rotated around the LE-RE line until the vertical centerline was in the reference plane.
4. The phone was then rotated around the vertical centerline until the phone (horizontal line) was symmetrical with respect to the line NF.
5. While maintaining the vertical centerline in the reference plane, keeping point A on the line passing through RE and LE, and maintaining the device contact with the ear, the device was rotated about the NF line until any point on the handset made contact with a phantom point below the ear (cheek) (See Figure 6-2).

### 6.3 Positioning for Ear / 15° Tilt

With the test device aligned in the “Cheek Position”:

1. While maintaining the orientation of the phone, the phone was retracted parallel to the reference plane far enough to enable a rotation of the phone by 15degrees.
2. The phone was then rotated around the horizontal line by 15 degrees.
3. While maintaining the orientation of the phone, the phone was moved parallel to the reference plane until any part of the handset touched the head. (In this position, point A was located on the line RE-LE). The tilted position is obtained when the contact is on the pinna. If the contact was at any location other than the pinna, the angle of the phone would then be reduced. In this situation, the tilted position was obtained when any part of the phone was in contact of the ear as well as a second part of the phone was in contact with the head (see Figure 6-2).

|                                   |  |                               |   |                                 |
|-----------------------------------|--|-------------------------------|---|---------------------------------|
| FCC ID: ACJEB3910A                |  PCTEST<br>ENGINEERING LABORATORY, INC. | SAR EVALUATION REPORT         |  Panasonic | Reviewed by:<br>Quality Manager |
| Document S/N:<br>0Y1510271888.ACJ | Test Dates:<br>10/28/15 - 11/03/15   | DUT Type:<br>Portable Handset |   | Page 11 of 31                   |

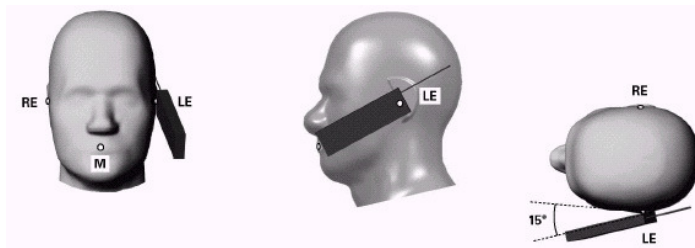

**Figure 6-2 Front, Side and Top View of Ear/15° Tilt Position**

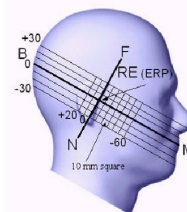

**Figure 6-3 Side view w/ relevant markings**

## 6.4 Body-Worn Accessory Configurations

Body-worn operating configurations are tested with the belt-clips and holsters attached to the device and positioned against a flat phantom in a normal use configuration (see Figure 6-4). Per FCC KDB Publication 648474 D04v01r02, Body-worn accessory exposure is typically related to voice mode operations when handsets are carried in body-worn accessories. The body-worn accessory procedures in FCC KDB Publication 447498 D01v05r02 should be used to test for body-worn accessory SAR compliance, without a headset connected to it. This enables the test results for such configuration to be compatible with that required for hotspot mode when the body-worn accessory test separation distance is greater than or equal to that required for hotspot mode, when applicable. When the reported SAR for a body-worn accessory, measured without a headset connected to the handset, is  $> 1.2 \text{ W/kg}$ , the highest reported SAR configuration for that wireless mode and frequency band should be repeated for that body-worn accessory with a headset attached to the handset.

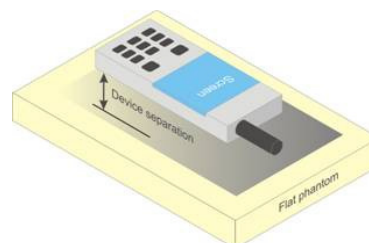



**Figure 6-4 Sample Body-Worn Diagram**

Accessories for Body-worn operation configurations are divided into two categories: those that do not contain metallic components and those that do contain metallic components. When multiple accessories that do not contain metallic components are supplied with the device, the device is tested with only the accessory that dictates the closest spacing to the body. Then multiple accessories that contain metallic components are tested with the device with each accessory. If multiple accessories share an identical metallic component (i.e. the same metallic belt-clip used with different holsters with no other metallic components) only the accessory that dictates the closest spacing to the body is tested.

Body-worn accessories may not always be supplied or available as options for some devices intended to be authorized for body-worn use. In this case, a test configuration with a separation distance between the back of the device and the flat phantom is used. Test position spacing was documented. Transmitters that are designed to operate in front of a person's face, as in push-to-talk configurations, are tested for SAR compliance with the front of the device positioned to face the flat phantom in head fluid. For devices that are carried next to the body such as a shoulder, waist or chest-worn transmitters, SAR compliance is tested with the accessories, including headsets and microphones, attached to the device and positioned against a flat phantom in a normal use configuration.

## 6.5 Extremity Exposure Configurations

Devices that are designed or intended for use on extremities or mainly operated in extremity only exposure conditions; i.e., hands, wrists, feet and ankles, may require extremity SAR evaluation. When the device also operates in close proximity to the user's body, SAR compliance for the body is also

|                                   |   |                               |   |                                 |
|-----------------------------------|---|-------------------------------|---|---------------------------------|
| FCC ID: ACJEB3910A                |  | SAR EVALUATION REPORT         |  | Reviewed by:<br>Quality Manager |
| Document S/N:<br>OY1510271888.ACJ | Test Dates:<br>10/28/15 - 11/03/15  | DUT Type:<br>Portable Handset |   | Page 12 of 31                   |

required. The 1-g body and 10-g extremity SAR Exclusion Thresholds found in KDB Publication 447498 D01v05r02 should be applied to determine SAR test requirements.



## 6.6 Wireless Router Configurations

Some battery-operated handsets have the capability to transmit and receive user data through simultaneous transmission of WIFI simultaneously with a separate licensed transmitter. The FCC has provided guidance in FCC KDB Publication 941225 D06v02 where SAR test considerations for handsets ( $L \times W \geq 9 \text{ cm} \times 5 \text{ cm}$ ) are based on a composite test separation distance of 10 mm from the front, back and edges of the device containing transmitting antennas within 2.5 cm of their edges, determined from general mixed use conditions for this type of devices. Since the hotspot SAR results may overlap with the body-worn accessory SAR requirements, the more conservative configurations can be considered, thus excluding some body-worn accessory SAR tests.

When the user enables the personal wireless router functions for the handset, actual operations include simultaneous transmission of both the WIFI transmitter and another licensed transmitter. Both transmitters often do not transmit at the same transmitting frequency and thus cannot be evaluated for SAR under actual use conditions due to the limitations of the SAR assessment probes. Therefore, SAR must be evaluated for each frequency transmission and mode separately and spatially summed with the WIFI transmitter according to FCC KDB Publication 447498 D01v05r02 procedures. The "Portable Hotspot" feature on the handset was NOT activated during SAR assessments, to ensure the SAR measurements were evaluated for a single transmission frequency RF signal at a time.

## 6.7 Phablet Configurations

For smart phones with a display diagonal dimension  $> 15.0 \text{ cm}$  or an overall diagonal dimension  $> 16.0 \text{ cm}$  that provide similar mobile web access and multimedia support found in mini-tablets or UMPC mini-tablets that support voice calls next to the ear, the phablets procedures outlined in KDB Publication 648474 D04 v01r02 should be applied to evaluate SAR compliance. A device marketed as phablets, regardless of form factors and operating characteristics must be tested as a phablet to determine SAR compliance. In addition to the normally required head and body-worn accessory SAR test procedures required for handsets, the UMPC mini-tablet procedures must also be applied to test the SAR of all surfaces and edges with an antenna  $\leq 25 \text{ mm}$  from that surface or edge, in direct contact with the phantom, for 10-g SAR. The UMPC mini-tablet 1-g SAR at 5 mm is not required. When hotspot mode applies, 10-g SAR is required only for the surfaces and edges with hotspot mode 1-g SAR  $> 1.2 \text{ W/kg}$ .

|                                   |   |                               |  |                                 |
|-----------------------------------|---|-------------------------------|--|---------------------------------|
| FCC ID: ACJEB3910A                |  <b>PCTEST</b><br>ENGINEERING LABORATORY, INC. | SAR EVALUATION REPORT         |  <b>Panasonic</b> | Reviewed by:<br>Quality Manager |
| Document S/N:<br>0Y1510271888.ACJ | Test Dates:<br>10/28/15 - 11/03/15  | DUT Type:<br>Portable Handset |  | Page 13 of 31                   |

# 7 RF EXPOSURE LIMITS

## 7.1 Uncontrolled Environment

UNCONTROLLED ENVIRONMENTS are defined as locations where there is the exposure of individuals who have no knowledge or control of their exposure. The general population/uncontrolled exposure limits are applicable to situations in which the general public may be exposed or in which persons who are exposed as a consequence of their employment may not be made fully aware of the potential for exposure or cannot exercise control over their exposure. Members of the general public would come under this category when exposure is not employment-related; for example, in the case of a wireless transmitter that exposes persons in its vicinity.



## 7.2 Controlled Environment

CONTROLLED ENVIRONMENTS are defined as locations where there is exposure that may be incurred by persons who are aware of the potential for exposure, (i.e. as a result of employment or occupation). In general, occupational/controlled exposure limits are applicable to situations in which persons are exposed as a consequence of their employment, who have been made fully aware of the potential for exposure and can exercise control over their exposure. This exposure category is also applicable when the exposure is of a transient nature due to incidental passage through a location where the exposure levels may be higher than the general population/uncontrolled limits, but the exposed person is fully aware of the potential for exposure and can exercise control over his or her exposure by leaving the area or by some other appropriate means.

**Table 7-1  
SAR Human Exposure Specified in ANSI/IEEE C95.1-1992 and Health Canada Safety Code 6**

| HUMAN EXPOSURE LIMITS   |   |   |
|---|---|---|
|   | UNCONTROLLED ENVIRONMENT<br><i>General Population</i><br>(W/kg) or (mW/g) | CONTROLLED ENVIRONMENT<br><i>Occupational</i><br>(W/kg) or (mW/g) |
| <b>Peak Spatial Average SAR</b><br>Head                             | 1.6   | 8.0   |
| <b>Whole Body SAR</b>   | 0.08  | 0.4   |
| <b>Peak Spatial Average SAR</b><br>Hands, Feet, Ankle, Wrists, etc. | 4.0   | 20  |

1. The Spatial Peak value of the SAR averaged over any 1 gram of tissue (defined as a tissue volume in the shape of a cube) and over the appropriate averaging time.
2. The Spatial Average value of the SAR averaged over the whole body.
3. The Spatial Peak value of the SAR averaged over any 10 grams of tissue (defined as a tissue volume in the shape of a cube) and over the appropriate averaging time.

|                                   |   |                               |   |                                 |
|-----------------------------------|---|-------------------------------|---|---------------------------------|
| FCC ID: ACJEB3910A                |  <b>PCTEST</b><br>ENGINEERING LABORATORY, INC. | SAR EVALUATION REPORT         |  | Reviewed by:<br>Quality Manager |
| Document S/N:<br>0Y1510271888.ACJ | Test Dates:<br>10/28/15 - 11/03/15  | DUT Type:<br>Portable Handset |   | Page 14 of 31                   |

## 8 FCC MEASUREMENT PROCEDURES

Power measurements for licensed transmitters are performed using a base station simulator under digital average power.

### 8.1 Measured and Reported SAR

Per FCC KDB Publication 447498 D01v05r02, when SAR is not measured at the maximum power level allowed for production units, the results must be scaled to the maximum tune-up tolerance limit according to the power applied to the individual channels tested to determine compliance. For simultaneous transmission, the measured aggregate SAR must be scaled according to the sum of the differences between the maximum tune-up tolerance and actual power used to test each transmitter. When SAR is measured at or scaled to the maximum tune-up tolerance limit, the results are referred to as *reported* SAR. The highest *reported* SAR results are identified on the grant of equipment authorization according to procedures in KDB 690783 D01v01r03.

### 8.2 Procedures Used to Establish RF Signal for SAR

The following procedures are according to FCC KDB Publication 941225 D01v03 “3G SAR Measurement Procedures.”

The device is placed into a simulated call using a base station simulator in a RF shielded chamber. Establishing connections in this manner ensure a consistent means for testing SAR and are recommended for evaluating SAR [4]. Devices under test are evaluated prior to testing, with a fully charged battery and were configured to operate at maximum output power. In order to verify that the device is tested throughout the SAR test at maximum output power, the SAR measurement system measures a “point SAR” at an arbitrary reference point at the start and end of the 1 gram SAR evaluation, to assess for any power drifts during the evaluation. If the power drift deviates by more than 5%, the SAR test and drift measurements are repeated.

### 8.3 SAR Measurement Conditions for LTE



LTE modes are tested according to FCC KDB 941225 D05v02r03 publication. Establishing connections with base station simulators ensure a consistent means for testing SAR and are recommended for evaluating SAR [4]. The R&S CMW500 or Anritsu MT8820C simulators are used for LTE output power measurements and SAR testing. Closed loop power control was used so the UE transmits with maximum output power during SAR testing. SAR tests were performed with the same number of RB and RB offsets transmitting on all TTI frames (maximum TTI).

#### 8.3.1 Spectrum Plots for RB Configurations

A properly configured base station simulator was used for SAR tests and power measurements. Therefore, spectrum plots for RB configurations were not required to be included in this report.

#### 8.3.2 MPR

MPR is permanently implemented for this device by the manufacturer. The specific manufacturer target MPR is indicated alongside the SAR results. MPR is enabled for this device, according to 3GPP TS36.101 Section 6.2.3 – 6.2.5 under Table 6.2.3-1.

|                                   |  |                               |   |                                 |
|-----------------------------------|--|-------------------------------|---|---------------------------------|
| FCC ID: ACJEB3910A                |  PCTEST<br>ENGINEERING LABORATORY, INC. | SAR EVALUATION REPORT         |  Panasonic | Reviewed by:<br>Quality Manager |
| Document S/N:<br>0Y1510271888.ACJ | Test Dates:<br>10/28/15 - 11/03/15   | DUT Type:<br>Portable Handset |   | Page 15 of 31                   |



### 8.3.3 A-MPR

A-MPR (Additional MPR) has been disabled for all SAR tests by setting NS=01 on the base station simulator.

### 8.3.4 Required RB Size and RB Offsets for SAR Testing

According to FCC KDB 941225 D05v02r03:

- a. Per Section 4.2.1, SAR is required for QPSK 1 RB Allocation for the largest bandwidth
  - i. The required channel and offset combination with the highest maximum output power is required for SAR.
  - ii. When the reported SAR is  $\leq 0.8$  W/kg, testing of the remaining RB offset configurations and required test channels is not required. Otherwise, SAR is required for the remaining required test channels using the RB offset configuration with highest output power for that channel.
  - iii. When the reported SAR for a required test channel is  $> 1.45$  W/kg, SAR is required for all RB offset configurations for that channel.
- b. Per Section 4.2.2, SAR is required for 50% RB allocation using the largest bandwidth following the same procedures outlined in Section 4.2.1.
- c. Per Section 4.2.3, QPSK SAR is not required for the 100% allocation when the highest maximum output power for the 100% allocation is less than the highest maximum output power of the 1 RB and 50% RB allocations and the reported SAR for the 1 RB and 50% RB allocations is  $< 0.8$  W/kg.
- d. Per Section 4.2.4 and 4.3, SAR tests for higher order modulations and lower bandwidths configurations are not required when the conducted power of the required test configurations determined by Sections 4.2.1 through 4.2.3 is less than or equal to  $\frac{1}{2}$  dB higher than the equivalent configuration using QPSK modulation and when the QPSK SAR for those configurations is  $< 1.45$  W/kg.

|                                   |   |                               |  |                                 |
|-----------------------------------|---|-------------------------------|--|---------------------------------|
| FCC ID: ACJEB3910A                |  <b>PCTEST</b><br>ENGINEERING LABORATORY, INC. | SAR EVALUATION REPORT         |  <b>Panasonic</b> | Reviewed by:<br>Quality Manager |
| Document S/N:<br>0Y1510271888.ACJ | Test Dates:<br>10/28/15 - 11/03/15  | DUT Type:<br>Portable Handset |  | Page 16 of 31                   |

# 9 RF CONDUCTED POWERS



## 9.1 LTE Conducted Powers

### 9.1.1 LTE Band 4 (AWS)

Table 9-1  
LTE Band 4 (AWS) Conducted Powers - 20 MHz Bandwidth



|     | Frequency [MHz] | Channel | Bandwidth [MHz] | Modulation | RB Size | RB Offset | Conducted Power [dBm] | MPR Allowed per 3GPP [dB] | MPR [dB] |
|-----|-----------------|---------|-----------------|------------|---------|-----------|-----------------------|---------------------------|----------|
| Mid | 1732.5          | 20175   | 20              | QPSK       | 1       | 0         | <b>23.40</b>          | 0                         | 0        |
|     | 1732.5          | 20175   | 20              | QPSK       | 1       | 50        | 23.24                 | 0                         | 0        |
|     | 1732.5          | 20175   | 20              | QPSK       | 1       | 99        | 23.05                 | 0                         | 0        |
|     | 1732.5          | 20175   | 20              | QPSK       | 50      | 0         | <b>22.18</b>          | 0-1                       | 1        |
|     | 1732.5          | 20175   | 20              | QPSK       | 50      | 25        | 22.14                 | 0-1                       | 1        |
|     | 1732.5          | 20175   | 20              | QPSK       | 50      | 50        | 22.08                 | 0-1                       | 1        |
|     | 1732.5          | 20175   | 20              | QPSK       | 100     | 0         | 22.14                 | 0-1                       | 1        |
|     | 1732.5          | 20175   | 20              | 16QAM      | 1       | 0         | 22.42                 | 0-1                       | 1        |
|     | 1732.5          | 20175   | 20              | 16QAM      | 1       | 50        | 22.45                 | 0-1                       | 1        |
|     | 1732.5          | 20175   | 20              | 16QAM      | 1       | 99        | 22.39                 | 0-1                       | 1        |
|     | 1732.5          | 20175   | 20              | 16QAM      | 50      | 0         | 21.15                 | 0-2                       | 2        |
|     | 1732.5          | 20175   | 20              | 16QAM      | 50      | 25        | 21.11                 | 0-2                       | 2        |
|     | 1732.5          | 20175   | 20              | 16QAM      | 50      | 50        | 21.04                 | 0-2                       | 2        |
|     | 1732.5          | 20175   | 20              | 16QAM      | 100     | 0         | 21.12                 | 0-2                       | 2        |

Note: LTE Band 4 (AWS) at 20 MHz bandwidth does not support three non-overlapping channels. Per KDB Publication 941225 D05v02, when a device supports overlapping channel assignment in a channel bandwidth configuration, the middle channel of the group of overlapping channels should be selected for testing.

|                                   |   |                               |   |                                 |
|-----------------------------------|---|-------------------------------|---|---------------------------------|
| FCC ID: ACJEB3910A                |  <b>PCTEST</b><br>ENGINEERING LABORATORY, INC. | SAR EVALUATION REPORT         |  | Reviewed by:<br>Quality Manager |
| Document S/N:<br>0Y1510271888.ACJ | Test Dates:<br>10/28/15 - 11/03/15  | DUT Type:<br>Portable Handset |   | Page 17 of 31                   |



**Table 9-2  
LTE Band 4 (AWS) Conducted Powers - 15 MHz Bandwidth**

|        | Frequency [MHz] | Channel | Bandwidth [MHz] | Modulation | RB Size | RB Offset | Conducted Power [dBm] | MPR Allowed per 3GPP [dB] | MPR [dB] |
|--------|-----------------|---------|-----------------|------------|---------|-----------|-----------------------|---------------------------|----------|
| Low    | 1717.5          | 20025   | 15              | QPSK       | 1       | 0         | 23.42                 | 0                         | 0        |
|        | 1717.5          | 20025   | 15              | QPSK       | 1       | 36        | 23.31                 | 0                         | 0        |
|        | 1717.5          | 20025   | 15              | QPSK       | 1       | 74        | 23.25                 | 0                         | 0        |
|        | 1717.5          | 20025   | 15              | QPSK       | 36      | 0         | 22.16                 | 0-1                       | 1        |
|        | 1717.5          | 20025   | 15              | QPSK       | 36      | 18        | 22.17                 | 0-1                       | 1        |
|        | 1717.5          | 20025   | 15              | QPSK       | 36      | 37        | 21.96                 | 0-1                       | 1        |
|        | 1717.5          | 20025   | 15              | QPSK       | 75      | 0         | 22.08                 | 0-1                       | 1        |
|        | 1717.5          | 20025   | 15              | 16QAM      | 1       | 0         | 22.25                 | 0-1                       | 1        |
|        | 1717.5          | 20025   | 15              | 16QAM      | 1       | 36        | 22.20                 | 0-1                       | 1        |
|        | 1717.5          | 20025   | 15              | 16QAM      | 1       | 74        | 22.22                 | 0-1                       | 1        |
|        | 1717.5          | 20025   | 15              | 16QAM      | 36      | 0         | 21.30                 | 0-2                       | 2        |
|        | 1717.5          | 20025   | 15              | 16QAM      | 36      | 18        | 21.32                 | 0-2                       | 2        |
| 1717.5 | 20025           | 15      | 16QAM           | 36         | 37      | 21.16     | 0-2                   | 2                         |          |
| 1717.5 | 20025           | 15      | 16QAM           | 75         | 0       | 21.10     | 0-2                   | 2                         |          |
| Mid    | 1732.5          | 20175   | 15              | QPSK       | 1       | 0         | 23.24                 | 0                         | 0        |
|        | 1732.5          | 20175   | 15              | QPSK       | 1       | 36        | 23.22                 | 0                         | 0        |
|        | 1732.5          | 20175   | 15              | QPSK       | 1       | 74        | 23.18                 | 0                         | 0        |
|        | 1732.5          | 20175   | 15              | QPSK       | 36      | 0         | 22.33                 | 0-1                       | 1        |
|        | 1732.5          | 20175   | 15              | QPSK       | 36      | 18        | 22.21                 | 0-1                       | 1        |
|        | 1732.5          | 20175   | 15              | QPSK       | 36      | 37        | 22.27                 | 0-1                       | 1        |
|        | 1732.5          | 20175   | 15              | QPSK       | 75      | 0         | 22.18                 | 0-1                       | 1        |
|        | 1732.5          | 20175   | 15              | 16QAM      | 1       | 0         | 22.45                 | 0-1                       | 1        |
|        | 1732.5          | 20175   | 15              | 16QAM      | 1       | 36        | 22.53                 | 0-1                       | 1        |
|        | 1732.5          | 20175   | 15              | 16QAM      | 1       | 74        | 22.32                 | 0-1                       | 1        |
|        | 1732.5          | 20175   | 15              | 16QAM      | 36      | 0         | 21.37                 | 0-2                       | 2        |
|        | 1732.5          | 20175   | 15              | 16QAM      | 36      | 18        | 21.29                 | 0-2                       | 2        |
| 1732.5 | 20175           | 15      | 16QAM           | 36         | 37      | 21.32     | 0-2                   | 2                         |          |
| 1732.5 | 20175           | 15      | 16QAM           | 75         | 0       | 21.19     | 0-2                   | 2                         |          |
| High   | 1747.5          | 20325   | 15              | QPSK       | 1       | 0         | 23.16                 | 0                         | 0        |
|        | 1747.5          | 20325   | 15              | QPSK       | 1       | 36        | 23.21                 | 0                         | 0        |
|        | 1747.5          | 20325   | 15              | QPSK       | 1       | 74        | 23.25                 | 0                         | 0        |
|        | 1747.5          | 20325   | 15              | QPSK       | 36      | 0         | 22.03                 | 0-1                       | 1        |
|        | 1747.5          | 20325   | 15              | QPSK       | 36      | 18        | 22.07                 | 0-1                       | 1        |
|        | 1747.5          | 20325   | 15              | QPSK       | 36      | 37        | 22.04                 | 0-1                       | 1        |
|        | 1747.5          | 20325   | 15              | QPSK       | 75      | 0         | 21.96                 | 0-1                       | 1        |
|        | 1747.5          | 20325   | 15              | 16QAM      | 1       | 0         | 21.91                 | 0-1                       | 1        |
|        | 1747.5          | 20325   | 15              | 16QAM      | 1       | 36        | 22.01                 | 0-1                       | 1        |
|        | 1747.5          | 20325   | 15              | 16QAM      | 1       | 74        | 22.11                 | 0-1                       | 1        |
|        | 1747.5          | 20325   | 15              | 16QAM      | 36      | 0         | 20.97                 | 0-2                       | 2        |
|        | 1747.5          | 20325   | 15              | 16QAM      | 36      | 18        | 21.02                 | 0-2                       | 2        |
| 1747.5 | 20325           | 15      | 16QAM           | 36         | 37      | 21.15     | 0-2                   | 2                         |          |
| 1747.5 | 20325           | 15      | 16QAM           | 75         | 0       | 21.07     | 0-2                   | 2                         |          |

|                                   |   |                               |   |                                 |
|-----------------------------------|---|-------------------------------|---|---------------------------------|
| FCC ID: ACJEB3910A                |  | SAR EVALUATION REPORT         |  | Reviewed by:<br>Quality Manager |
| Document S/N:<br>0Y1510271888.ACJ | Test Dates:<br>10/28/15 - 11/03/15  | DUT Type:<br>Portable Handset |   | Page 18 of 31                   |



**Table 9-3  
LTE Band 4 (AWS) Conducted Powers - 10 MHz Bandwidth**

|      | Frequency [MHz] | Channel | Bandwidth [MHz] | Modulation | RB Size | RB Offset | Conducted Power [dBm] | MPR Allowed per 3GPP [dB] | MPR [dB] |
|------|-----------------|---------|-----------------|------------|---------|-----------|-----------------------|---------------------------|----------|
| Low  | 1715            | 20000   | 10              | QPSK       | 1       | 0         | 23.01                 | 0                         | 0        |
|      | 1715            | 20000   | 10              | QPSK       | 1       | 25        | 22.98                 | 0                         | 0        |
|      | 1715            | 20000   | 10              | QPSK       | 1       | 49        | 22.87                 | 0                         | 0        |
|      | 1715            | 20000   | 10              | QPSK       | 25      | 0         | 21.93                 | 0-1                       | 1        |
|      | 1715            | 20000   | 10              | QPSK       | 25      | 12        | 21.80                 | 0-1                       | 1        |
|      | 1715            | 20000   | 10              | QPSK       | 25      | 25        | 21.79                 | 0-1                       | 1        |
|      | 1715            | 20000   | 10              | QPSK       | 50      | 0         | 21.79                 | 0-1                       | 1        |
|      | 1715            | 20000   | 10              | 16QAM      | 1       | 0         | 22.03                 | 0-1                       | 1        |
|      | 1715            | 20000   | 10              | 16QAM      | 1       | 25        | 21.91                 | 0-1                       | 1        |
|      | 1715            | 20000   | 10              | 16QAM      | 1       | 49        | 21.94                 | 0-1                       | 1        |
|      | 1715            | 20000   | 10              | 16QAM      | 25      | 0         | 20.99                 | 0-2                       | 2        |
|      | 1715            | 20000   | 10              | 16QAM      | 25      | 12        | 20.90                 | 0-2                       | 2        |
|      | 1715            | 20000   | 10              | 16QAM      | 25      | 25        | 20.85                 | 0-2                       | 2        |
| Mid  | 1732.5          | 20175   | 10              | QPSK       | 1       | 0         | 23.07                 | 0                         | 0        |
|      | 1732.5          | 20175   | 10              | QPSK       | 1       | 25        | 22.99                 | 0                         | 0        |
|      | 1732.5          | 20175   | 10              | QPSK       | 1       | 49        | 22.87                 | 0                         | 0        |
|      | 1732.5          | 20175   | 10              | QPSK       | 25      | 0         | 21.88                 | 0-1                       | 1        |
|      | 1732.5          | 20175   | 10              | QPSK       | 25      | 12        | 21.85                 | 0-1                       | 1        |
|      | 1732.5          | 20175   | 10              | QPSK       | 25      | 25        | 21.78                 | 0-1                       | 1        |
|      | 1732.5          | 20175   | 10              | QPSK       | 50      | 0         | 21.71                 | 0-1                       | 1        |
|      | 1732.5          | 20175   | 10              | 16QAM      | 1       | 0         | 22.11                 | 0-1                       | 1        |
|      | 1732.5          | 20175   | 10              | 16QAM      | 1       | 25        | 22.06                 | 0-1                       | 1        |
|      | 1732.5          | 20175   | 10              | 16QAM      | 1       | 49        | 21.89                 | 0-1                       | 1        |
|      | 1732.5          | 20175   | 10              | 16QAM      | 25      | 0         | 20.90                 | 0-2                       | 2        |
|      | 1732.5          | 20175   | 10              | 16QAM      | 25      | 12        | 20.78                 | 0-2                       | 2        |
|      | 1732.5          | 20175   | 10              | 16QAM      | 25      | 25        | 20.77                 | 0-2                       | 2        |
| High | 1750            | 20350   | 10              | QPSK       | 1       | 0         | 22.94                 | 0                         | 0        |
|      | 1750            | 20350   | 10              | QPSK       | 1       | 25        | 22.84                 | 0                         | 0        |
|      | 1750            | 20350   | 10              | QPSK       | 1       | 49        | 23.04                 | 0                         | 0        |
|      | 1750            | 20350   | 10              | QPSK       | 25      | 0         | 21.63                 | 0-1                       | 1        |
|      | 1750            | 20350   | 10              | QPSK       | 25      | 12        | 21.70                 | 0-1                       | 1        |
|      | 1750            | 20350   | 10              | QPSK       | 25      | 25        | 21.67                 | 0-1                       | 1        |
|      | 1750            | 20350   | 10              | QPSK       | 50      | 0         | 21.58                 | 0-1                       | 1        |
|      | 1750            | 20350   | 10              | 16QAM      | 1       | 0         | 21.95                 | 0-1                       | 1        |
|      | 1750            | 20350   | 10              | 16QAM      | 1       | 25        | 21.90                 | 0-1                       | 1        |
|      | 1750            | 20350   | 10              | 16QAM      | 1       | 49        | 22.02                 | 0-1                       | 1        |
|      | 1750            | 20350   | 10              | 16QAM      | 25      | 0         | 20.71                 | 0-2                       | 2        |
|      | 1750            | 20350   | 10              | 16QAM      | 25      | 12        | 20.75                 | 0-2                       | 2        |
|      | 1750            | 20350   | 10              | 16QAM      | 25      | 25        | 20.77                 | 0-2                       | 2        |
| 1750 | 20350           | 10      | 16QAM           | 50         | 0       | 20.66     | 0-2                   | 2                         |          |

|                                   |   |                               |   |                                 |
|-----------------------------------|---|-------------------------------|---|---------------------------------|
| FCC ID: ACJEB3910A                |  | SAR EVALUATION REPORT         |  | Reviewed by:<br>Quality Manager |
| Document S/N:<br>0Y1510271888.ACJ | Test Dates:<br>10/28/15 - 11/03/15  | DUT Type:<br>Portable Handset |   | Page 19 of 31                   |

**Table 9-4  
LTE Band 4 (AWS) Conducted Powers - 5 MHz Bandwidth**

|        | Frequency [MHz] | Channel | Bandwidth [MHz] | Modulation | RB Size | RB Offset | Conducted Power [dBm] | MPR Allowed per 3GPP [dB] | MPR [dB] |
|--------|-----------------|---------|-----------------|------------|---------|-----------|-----------------------|---------------------------|----------|
| Low    | 1712.5          | 19975   | 5               | QPSK       | 1       | 0         | 23.06                 | 0                         | 0        |
|        | 1712.5          | 19975   | 5               | QPSK       | 1       | 12        | 23.05                 | 0                         | 0        |
|        | 1712.5          | 19975   | 5               | QPSK       | 1       | 24        | 22.95                 | 0                         | 0        |
|        | 1712.5          | 19975   | 5               | QPSK       | 12      | 0         | 22.46                 | 0-1                       | 1        |
|        | 1712.5          | 19975   | 5               | QPSK       | 12      | 6         | 22.47                 | 0-1                       | 1        |
|        | 1712.5          | 19975   | 5               | QPSK       | 12      | 13        | 22.47                 | 0-1                       | 1        |
|        | 1712.5          | 19975   | 5               | QPSK       | 25      | 0         | 22.34                 | 0-1                       | 1        |
|        | 1712.5          | 19975   | 5               | 16-QAM     | 1       | 0         | 22.04                 | 0-1                       | 1        |
|        | 1712.5          | 19975   | 5               | 16-QAM     | 1       | 12        | 22.08                 | 0-1                       | 1        |
|        | 1712.5          | 19975   | 5               | 16-QAM     | 1       | 24        | 21.97                 | 0-1                       | 1        |
|        | 1712.5          | 19975   | 5               | 16-QAM     | 12      | 0         | 21.45                 | 0-2                       | 2        |
|        | 1712.5          | 19975   | 5               | 16-QAM     | 12      | 6         | 21.49                 | 0-2                       | 2        |
| 1712.5 | 19975           | 5       | 16-QAM          | 12         | 13      | 21.44     | 0-2                   | 2                         |          |
| 1712.5 | 19975           | 5       | 16-QAM          | 25         | 0       | 21.25     | 0-2                   | 2                         |          |
| Mid    | 1732.5          | 20175   | 5               | QPSK       | 1       | 0         | 23.11                 | 0                         | 0        |
|        | 1732.5          | 20175   | 5               | QPSK       | 1       | 12        | 23.03                 | 0                         | 0        |
|        | 1732.5          | 20175   | 5               | QPSK       | 1       | 24        | 23.05                 | 0                         | 0        |
|        | 1732.5          | 20175   | 5               | QPSK       | 12      | 0         | 22.40                 | 0-1                       | 1        |
|        | 1732.5          | 20175   | 5               | QPSK       | 12      | 6         | 22.28                 | 0-1                       | 1        |
|        | 1732.5          | 20175   | 5               | QPSK       | 12      | 13        | 22.31                 | 0-1                       | 1        |
|        | 1732.5          | 20175   | 5               | QPSK       | 25      | 0         | 22.29                 | 0-1                       | 1        |
|        | 1732.5          | 20175   | 5               | 16-QAM     | 1       | 0         | 22.05                 | 0-1                       | 1        |
|        | 1732.5          | 20175   | 5               | 16-QAM     | 1       | 12        | 22.10                 | 0-1                       | 1        |
|        | 1732.5          | 20175   | 5               | 16-QAM     | 1       | 24        | 21.97                 | 0-1                       | 1        |
|        | 1732.5          | 20175   | 5               | 16-QAM     | 12      | 0         | 21.43                 | 0-2                       | 2        |
|        | 1732.5          | 20175   | 5               | 16-QAM     | 12      | 6         | 21.47                 | 0-2                       | 2        |
| 1732.5 | 20175           | 5       | 16-QAM          | 12         | 13      | 21.47     | 0-2                   | 2                         |          |
| 1732.5 | 20175           | 5       | 16-QAM          | 25         | 0       | 21.33     | 0-2                   | 2                         |          |
| High   | 1752.5          | 20375   | 5               | QPSK       | 1       | 0         | 23.01                 | 0                         | 0        |
|        | 1752.5          | 20375   | 5               | QPSK       | 1       | 12        | 22.94                 | 0                         | 0        |
|        | 1752.5          | 20375   | 5               | QPSK       | 1       | 24        | 23.15                 | 0                         | 0        |
|        | 1752.5          | 20375   | 5               | QPSK       | 12      | 0         | 22.47                 | 0-1                       | 1        |
|        | 1752.5          | 20375   | 5               | QPSK       | 12      | 6         | 22.36                 | 0-1                       | 1        |
|        | 1752.5          | 20375   | 5               | QPSK       | 12      | 13        | 22.47                 | 0-1                       | 1        |
|        | 1752.5          | 20375   | 5               | QPSK       | 25      | 0         | 22.32                 | 0-1                       | 1        |
|        | 1752.5          | 20375   | 5               | 16-QAM     | 1       | 0         | 21.99                 | 0-1                       | 1        |
|        | 1752.5          | 20375   | 5               | 16-QAM     | 1       | 12        | 22.06                 | 0-1                       | 1        |
|        | 1752.5          | 20375   | 5               | 16-QAM     | 1       | 24        | 22.11                 | 0-1                       | 1        |
|        | 1752.5          | 20375   | 5               | 16-QAM     | 12      | 0         | 21.50                 | 0-2                       | 2        |
|        | 1752.5          | 20375   | 5               | 16-QAM     | 12      | 6         | 21.49                 | 0-2                       | 2        |
| 1752.5 | 20375           | 5       | 16-QAM          | 12         | 13      | 21.50     | 0-2                   | 2                         |          |
| 1752.5 | 20375           | 5       | 16-QAM          | 25         | 0       | 21.36     | 0-2                   | 2                         |          |

|                                   |   |                               |   |                                 |
|-----------------------------------|---|-------------------------------|---|---------------------------------|
| FCC ID: ACJEB3910A                |  | SAR EVALUATION REPORT         |  | Reviewed by:<br>Quality Manager |
| Document S/N:<br>OY1510271888.ACJ | Test Dates:<br>10/28/15 - 11/03/15  | DUT Type:<br>Portable Handset |   | Page 20 of 31                   |

# 10 SYSTEM VERIFICATION

## 10.1 Tissue Verification

**Table 10-1  
Measured Tissue Properties**

| Calibrated for Tests Performed on: | Tissue Type | Tissue Temp During Calibration (C°) | Measured Frequency (MHz) | Measured Conductivity, $\sigma$ (S/m) | Measured Dielectric Constant, $\epsilon$ | TARGET Conductivity, $\sigma$ (S/m) | TARGET Dielectric Constant, $\epsilon$ | % dev $\sigma$ | % dev $\epsilon$ |
|------------------------------------|-------------|-------------------------------------|--------------------------|---------------------------------------|--|-------------------------------------|--|----------------|------------------|
| 11/3/2015                          | 1750H       | 22.7                                | 1710                     | 1.307                                 | 38.773                                   | 1.348                               | 40.142                                 | -3.04%         | -3.41%           |
|                                    |             |                                     | 1750                     | 1.349                                 | 38.601                                   | 1.371                               | 40.079                                 | -1.60%         | -3.69%           |
|                                    |             |                                     | 1790                     | 1.389                                 | 38.415                                   | 1.394                               | 40.016                                 | -0.36%         | -4.00%           |
| 10/28/2015                         | 1750B       | 21.8                                | 1710                     | 1.415                                 | 51.903                                   | 1.463                               | 53.537                                 | -3.28%         | -3.05%           |
|                                    |             |                                     | 1750                     | 1.457                                 | 51.783                                   | 1.488                               | 53.432                                 | -2.08%         | -3.09%           |
|                                    |             |                                     | 1790                     | 1.505                                 | 51.630                                   | 1.514                               | 53.326                                 | -0.59%         | -3.18%           |

The above measured tissue parameters were used in the DASY software. The DASY software was used to perform interpolation to determine the dielectric parameters at the SAR test device frequencies (per KDB Publication 865664 D01v01r04 and IEEE 1528-2013 6.6.1.2). The tissue parameters listed in the SAR test plots may slightly differ from the table above due to significant digit rounding in the software.

## 10.2 Test System Verification

Prior to SAR assessment, the system is verified to  $\pm 10\%$  of the SAR measurement on the reference dipole at the time of calibration by the calibration facility. Full system validation status and result summary can be found in Appendix E.

**Table 10-2  
System Verification Results – 1g**

| System Verification<br>TARGET & MEASURED |                        |             |            |                |                  |                 |           |          |                                   |                                     |   |                             |
|--|------------------------|-------------|------------|----------------|------------------|-----------------|-----------|----------|-----------------------------------|-------------------------------------|---|-----------------------------|
| SAR System #                             | Tissue Frequency (MHz) | Tissue Type | Date:      | Amb. Temp (°C) | Liquid Temp (°C) | Input Power (W) | Dipole SN | Probe SN | Measured SAR <sub>1g</sub> (W/kg) | 1 W Target SAR <sub>1g</sub> (W/kg) | 1 W Normalized SAR <sub>1g</sub> (W/kg) | Deviation <sub>1g</sub> (%) |
| I  | 1750                   | HEAD        | 11/03/2015 | 22.4           | 22.7             | 0.100           | 1051      | 3213     | 3.590                             | 36.200                              | 35.900                                  | -0.83%                      |
| H  | 1750                   | BODY        | 10/28/2015 | 22.3           | 21.8             | 0.100           | 1051      | 3263     | 3.730                             | 37.100                              | 37.300                                  | 0.54%                       |

**Table 10-3  
System Verification Results – 10g**

| System Verification<br>TARGET & MEASURED |                        |             |            |                |                  |                 |           |          |                                    |                                      |  |                              |
|--|------------------------|-------------|------------|----------------|------------------|-----------------|-----------|----------|------------------------------------|--------------------------------------|--|------------------------------|
| SAR System #                             | Tissue Frequency (MHz) | Tissue Type | Date:      | Amb. Temp (°C) | Liquid Temp (°C) | Input Power (W) | Dipole SN | Probe SN | Measured SAR <sub>10g</sub> (W/kg) | 1 W Target SAR <sub>10g</sub> (W/kg) | 1 W Normalized SAR <sub>10g</sub> (W/kg) | Deviation <sub>10g</sub> (%) |
| H  | 1750                   | BODY        | 10/28/2015 | 22.3           | 21.8             | 0.100           | 1051      | 3263     | 2.010                              | 20.000                               | 20.100                                   | 0.50%                        |

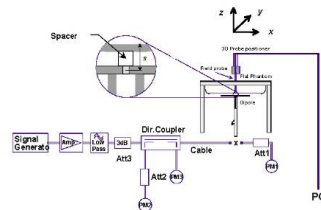

**Figure 10-1  
System Verification Setup Diagram**



**Figure 10-2  
System Verification Setup Photo**

|                                   |  |                               |           |                                 |
|-----------------------------------|--|-------------------------------|-----------|---------------------------------|
| FCC ID: ACJEB3910A                | PCTEST<br>ENGINEERING LABORATORY, INC. | SAR EVALUATION REPORT         | Panasonic | Reviewed by:<br>Quality Manager |
| Document S/N:<br>0Y1510271888.ACJ | Test Dates:<br>10/28/15 - 11/03/15     | DUT Type:<br>Portable Handset |           | Page 21 of 31                   |

# 11 SAR DATA SUMMARY

## 11.1 Standalone Head SAR Data

**Table 11-1**  
**LTE Band 4 (AWS) Head SAR**

| MEASUREMENT RESULTS   |       |      |                  |                             |                       |                  |          |      |               |   |         |           |                      |            |                 |                |                          |        |    |
|---|-------|------|------------------|-----------------------------|-----------------------|------------------|----------|------|---------------|---|---------|-----------|----------------------|------------|-----------------|----------------|--------------------------|--------|----|
| FREQUENCY   |       | Mode | Bandwidth [MHz]  | Maximum Allowed Power [dBm] | Conducted Power [dBm] | Power Drift [dB] | MPR [dB] | Side | Test Position | Modulation                                      | RB Size | RB Offset | Device Serial Number | Duty Cycle | SAR (1g) (W/kg) | Scaling Factor | Reported SAR (1g) (W/kg) | Plot # |    |
| MHz   | Ch.   |      |                  |                             |                       |                  |          |      |               |   |         |           |                      |            |                 |                |                          |        |    |
| 1732.50   | 20175 | Mid  | LTE Band 4 (AWS) | 20                          | 23.9                  | 23.40            | -0.05    | 0    | Right         | Cheek   | QPSK    | 1         | 0                    | 22046      | 1:1             | 0.280          | 1.122                    | 0.314  |    |
| 1732.50   | 20175 | Mid  | LTE Band 4 (AWS) | 20                          | 22.9                  | 22.18            | -0.01    | 1    | Right         | Cheek   | QPSK    | 50        | 0                    | 22046      | 1:1             | 0.222          | 1.180                    | 0.262  |    |
| 1732.50   | 20175 | Mid  | LTE Band 4 (AWS) | 20                          | 23.9                  | 23.40            | -0.05    | 0    | Right         | Tilt  | QPSK    | 1         | 0                    | 22046      | 1:1             | 0.199          | 1.122                    | 0.223  |    |
| 1732.50   | 20175 | Mid  | LTE Band 4 (AWS) | 20                          | 22.9                  | 22.18            | -0.12    | 1    | Right         | Tilt  | QPSK    | 50        | 0                    | 22046      | 1:1             | 0.148          | 1.180                    | 0.175  |    |
| 1732.50   | 20175 | Mid  | LTE Band 4 (AWS) | 20                          | 23.9                  | 23.40            | 0.01     | 0    | Left          | Cheek   | QPSK    | 1         | 0                    | 22046      | 1:1             | 0.500          | 1.122                    | 0.561  | A1 |
| 1732.50   | 20175 | Mid  | LTE Band 4 (AWS) | 20                          | 22.9                  | 22.18            | -0.06    | 1    | Left          | Cheek   | QPSK    | 50        | 0                    | 22046      | 1:1             | 0.370          | 1.180                    | 0.437  |    |
| 1732.50   | 20175 | Mid  | LTE Band 4 (AWS) | 20                          | 23.9                  | 23.40            | 0.09     | 0    | Left          | Tilt  | QPSK    | 1         | 0                    | 22046      | 1:1             | 0.209          | 1.122                    | 0.234  |    |
| 1732.50   | 20175 | Mid  | LTE Band 4 (AWS) | 20                          | 22.9                  | 22.18            | -0.02    | 1    | Left          | Tilt  | QPSK    | 50        | 0                    | 22046      | 1:1             | 0.154          | 1.180                    | 0.182  |    |
| ANSI / IEEE C95.1 1992 - SAFETY LIMIT<br>Spatial Peak<br>Uncontrolled Exposure/General Population |       |      |                  |                             |                       |                  |          |      |               | Head<br>1.6 W/kg (mW/g)<br>averaged over 1 gram |         |           |                      |            |                 |                |                          |        |    |

## 11.2 Standalone Body-Worn SAR Data



**Table 11-2**  
**LTE Body-Worn SAR**

| MEASUREMENT RESULTS   |       |      |                  |                |                             |                       |                  |          |                      |   |         |           |         |       |            |                 |                |                          |        |    |
|---|-------|------|------------------|----------------|-----------------------------|-----------------------|------------------|----------|----------------------|---|---------|-----------|---------|-------|------------|-----------------|----------------|--------------------------|--------|----|
| FREQUENCY   |       | Mode | Bandwidth [MHz]  | Accessory Type | Maximum Allowed Power [dBm] | Conducted Power [dBm] | Power Drift [dB] | MPR [dB] | Device Serial Number | Modulation                                      | RB Size | RB Offset | Spacing | Side  | Duty Cycle | SAR (1g) (W/kg) | Scaling Factor | Reported SAR (1g) (W/kg) | Plot # |    |
| MHz   | Ch.   |      |                  |                |                             |                       |                  |          |                      |   |         |           |         |       |            |                 |                |                          |        |    |
| 1732.50   | 20175 | Mid  | LTE Band 4 (AWS) | 20             | Body Holster                | 23.9                  | 23.40            | -0.04    | 0                    | 22046   | QPSK    | 1         | 0       | 0 mm  | back       | 1:1             | 0.077          | 1.122                    | 0.086  |    |
| 1732.50   | 20175 | Mid  | LTE Band 4 (AWS) | 20             | Body Holster                | 22.9                  | 22.18            | -0.04    | 1                    | 22046   | QPSK    | 50        | 0       | 0 mm  | back       | 1:1             | 0.057          | 1.180                    | 0.067  |    |
| 1732.50   | 20175 | Mid  | LTE Band 4 (AWS) | 20             | Body Holster                | 23.9                  | 23.40            | 0.04     | 0                    | 22046   | QPSK    | 1         | 0       | 0 mm  | front      | 1:1             | 0.250          | 1.122                    | 0.281  | A2 |
| 1732.50   | 20175 | Mid  | LTE Band 4 (AWS) | 20             | Body Holster                | 22.9                  | 22.18            | 0.00     | 1                    | 22046   | QPSK    | 50        | 0       | 0 mm  | front      | 1:1             | 0.194          | 1.180                    | 0.229  |    |
| 1732.50   | 20175 | Mid  | LTE Band 4 (AWS) | 20             | None                        | 23.9                  | 23.40            | -0.05    | 0                    | 22046   | QPSK    | 1         | 0       | 10 mm | back       | 1:1             | 0.177          | 1.122                    | 0.199  |    |
| 1732.50   | 20175 | Mid  | LTE Band 4 (AWS) | 20             | None                        | 22.9                  | 22.18            | -0.20    | 1                    | 22046   | QPSK    | 50        | 0       | 10 mm | back       | 1:1             | 0.134          | 1.180                    | 0.158  |    |
| ANSI / IEEE C95.1 1992 - SAFETY LIMIT<br>Spatial Peak<br>Uncontrolled Exposure/General Population |       |      |                  |                |                             |                       |                  |          |                      | Body<br>1.6 W/kg (mW/g)<br>averaged over 1 gram |         |           |         |       |            |                 |                |                          |        |    |

## 11.3 Standalone Wireless Router SAR Data

**Table 11-3**  
**LTE Band 4 (AWS) Hotspot SAR**

| MEASUREMENT RESULTS   |       |      |                  |                             |                       |                  |          |                      |            |   |           |         |       |            |                 |                |                          |        |    |
|---|-------|------|------------------|-----------------------------|-----------------------|------------------|----------|----------------------|------------|---|-----------|---------|-------|------------|-----------------|----------------|--------------------------|--------|----|
| FREQUENCY   |       | Mode | Bandwidth [MHz]  | Maximum Allowed Power [dBm] | Conducted Power [dBm] | Power Drift [dB] | MPR [dB] | Device Serial Number | Modulation | RB Size   | RB Offset | Spacing | Side  | Duty Cycle | SAR (1g) (W/kg) | Scaling Factor | Reported SAR (1g) (W/kg) | Plot # |    |
| MHz   | Ch.   |      |                  |                             |                       |                  |          |                      |            |   |           |         |       |            |                 |                |                          |        |    |
| 1732.50   | 20175 | Mid  | LTE Band 4 (AWS) | 20                          | 23.9                  | 23.40            | -0.05    | 0                    | 22046      | QPSK  | 1         | 0       | 10 mm | back       | 1:1             | 0.177          | 1.122                    | 0.199  |    |
| 1732.50   | 20175 | Mid  | LTE Band 4 (AWS) | 20                          | 22.9                  | 22.18            | -0.20    | 1                    | 22046      | QPSK  | 50        | 0       | 10 mm | back       | 1:1             | 0.134          | 1.180                    | 0.158  |    |
| 1732.50   | 20175 | Mid  | LTE Band 4 (AWS) | 20                          | 23.9                  | 23.40            | 0.04     | 0                    | 22046      | QPSK  | 1         | 0       | 10 mm | front      | 1:1             | 0.612          | 1.122                    | 0.687  | A3 |
| 1732.50   | 20175 | Mid  | LTE Band 4 (AWS) | 20                          | 22.9                  | 22.18            | -0.01    | 1                    | 22046      | QPSK  | 50        | 0       | 10 mm | front      | 1:1             | 0.462          | 1.180                    | 0.545  |    |
| 1732.50   | 20175 | Mid  | LTE Band 4 (AWS) | 20                          | 23.9                  | 23.40            | 0.03     | 0                    | 22046      | QPSK  | 1         | 0       | 10 mm | bottom     | 1:1             | 0.386          | 1.122                    | 0.433  |    |
| 1732.50   | 20175 | Mid  | LTE Band 4 (AWS) | 20                          | 22.9                  | 22.18            | 0.02     | 1                    | 22046      | QPSK  | 50        | 0       | 10 mm | bottom     | 1:1             | 0.311          | 1.180                    | 0.367  |    |
| 1732.50   | 20175 | Mid  | LTE Band 4 (AWS) | 20                          | 23.9                  | 23.40            | 0.05     | 0                    | 22046      | QPSK  | 1         | 0       | 10 mm | right      | 1:1             | 0.066          | 1.122                    | 0.074  |    |
| 1732.50   | 20175 | Mid  | LTE Band 4 (AWS) | 20                          | 22.9                  | 22.18            | -0.02    | 1                    | 22046      | QPSK  | 50        | 0       | 10 mm | right      | 1:1             | 0.055          | 1.180                    | 0.065  |    |
| 1732.50   | 20175 | Mid  | LTE Band 4 (AWS) | 20                          | 23.9                  | 23.40            | 0.02     | 0                    | 22046      | QPSK  | 1         | 0       | 10 mm | left       | 1:1             | 0.326          | 1.122                    | 0.366  |    |
| 1732.50   | 20175 | Mid  | LTE Band 4 (AWS) | 20                          | 22.9                  | 22.18            | 0.01     | 1                    | 22046      | QPSK  | 50        | 0       | 10 mm | left       | 1:1             | 0.268          | 1.180                    | 0.316  |    |
| ANSI / IEEE C95.1 1992 - SAFETY LIMIT<br>Spatial Peak<br>Uncontrolled Exposure/General Population |       |      |                  |                             |                       |                  |          |                      |            | Body<br>1.6 W/kg (mW/g)<br>averaged over 1 gram |           |         |       |            |                 |                |                          |        |    |

|                                   |   |                               |   |                                 |
|-----------------------------------|---|-------------------------------|---|---------------------------------|
| FCC ID: ACJEB3910A                |  | SAR EVALUATION REPORT         |  | Reviewed by:<br>Quality Manager |
| Document S/N:<br>OY1510271888.ACJ | Test Dates:<br>10/28/15 - 11/03/15  | DUT Type:<br>Portable Handset |   | Page 22 of 31                   |

## 11.4 Standalone Extremity SAR Data

**Table 11-4  
Extremity SAR Data**

| MEASUREMENT RESULTS                                   |       |      |                  |                |                             |                       |                  |          |                      |  |         |           |         |      |            |                  |                |                           |        |    |
|---|-------|------|------------------|----------------|-----------------------------|-----------------------|------------------|----------|----------------------|--|---------|-----------|---------|------|------------|------------------|----------------|---------------------------|--------|----|
| FREQUENCY   |       | Mode | Bandwidth [MHz]  | Accessory Type | Maximum Allowed Power [dBm] | Conducted Power [dBm] | Power Drift [dB] | MPR [dB] | Device Serial Number | Modulation   | RB Size | RB Offset | Spacing | Side | Duty Cycle | SAR (10g) (W/kg) | Scaling Factor | Reported SAR (10g) (W/kg) | Plot # |    |
| MHz   | Ch.   |      |                  |                |                             |                       |                  |          |                      |  |         |           |         |      |            |                  |                |                           |        |    |
| 1732.50   | 20175 | Mid  | LTE Band 4 (AWS) | 20             | Hand Strap, Top-Right       | 23.9                  | 23.40            | -0.05    | 0                    | 22046  | QPSK    | 1         | 0       | 0 mm | back       | 1:1              | 0.262          | 1.122                     | 0.294  | A4 |
| 1732.50   | 20175 | Mid  | LTE Band 4 (AWS) | 20             | Hand Strap, Top-Right       | 22.9                  | 22.18            | 0.01     | 1                    | 22046  | QPSK    | 50        | 0       | 0 mm | back       | 1:1              | 0.201          | 1.180                     | 0.237  |    |
| 1732.50   | 20175 | Mid  | LTE Band 4 (AWS) | 20             | Hand Strap, Top-Left        | 23.9                  | 23.40            | 0.03     | 0                    | 22046  | QPSK    | 1         | 0       | 0 mm | back       | 1:1              | 0.178          | 1.122                     | 0.200  |    |
| 1732.50   | 20175 | Mid  | LTE Band 4 (AWS) | 20             | Hand Strap, Top-Left        | 22.9                  | 22.18            | 0.06     | 1                    | 22046  | QPSK    | 50        | 0       | 0 mm | back       | 1:1              | 0.135          | 1.180                     | 0.159  |    |
| ANSI / IEEE C95.1 1992 - SAFETY LIMIT<br>Spatial Peak |       |      |                  |                |                             |                       |                  |          |                      | Extremity<br>4.0 W/kg (mW/g)<br>averaged over 10 grams |         |           |         |      |            |                  |                |                           |        |    |
| Uncontrolled Exposure/General Population              |       |      |                  |                |                             |                       |                  |          |                      |  |         |           |         |      |            |                  |                |                           |        |    |



## 11.5 SAR Test Notes

### General Notes:

- The test data reported are the worst-case SAR values according to test procedures specified in IEEE 1528-2003, and FCC KDB Publication 447498 D01v05r02.
- Batteries are fully charged at the beginning of the SAR measurements.
- Liquid tissue depth was at least 15.0 cm for all frequencies.
- The manufacturer has confirmed that the device(s) tested have the same physical, mechanical and thermal characteristics and are within operational tolerances expected for production units.
- SAR results were scaled to the maximum allowed power to demonstrate compliance per FCC KDB Publication 447498 D01v05r02.
- Device was tested using a fixed spacing for body-worn accessory testing. A separation distance of 10 mm was considered because the manufacturer has determined that there will be body-worn accessories available in the marketplace for users to support this separation distance.
- Per FCC KDB Publication 648474 D04v01r02, body-worn SAR was evaluated without a headset connected to the device. Since the standalone reported body-worn SAR was  $\leq 1.2$  W/kg, no additional body-worn SAR evaluations using a headset cable were required.
- Per FCC KDB 865664 D01v01r04, variability SAR tests were not performed since the measured SAR results for a frequency band were not greater than 0.8 W/kg. Please see Section 13 for variability analysis.
- Per FCC KDB Publication 648474 D04v01r02, this device is considered a "phablet" since the diagonal dimension is  $> 160$  mm and  $< 200$  mm. Therefore, Extremity SAR tests are required when wireless router mode does not apply or if wireless router 1g SAR  $> 1.2$  W/kg.
- Per FCC KDB Publication 447498 D01 v05r01, the metallic body-worn accessories (body-holster and hand strap) were tested in conjunction with the host device to demonstrate compliance. The belt holster was evaluated as a body-worn accessory with front and back side evaluated for 1g body-worn SAR with the belt holster for each wireless technology and frequency band at 0mm from the phantom. The hand strap accessory was evaluated for compliance by measuring back side 10g extremity SAR at 0mm for each wireless technology and frequency band for both diagonal orientations of the metallic components.

### LTE Notes:

- LTE Considerations: LTE test configurations are determined according to SAR Evaluation Considerations for LTE Devices in FCC KDB Publication 941225 D05v02r03. The general test procedures used for testing can be found in Section 8.3.4.
- MPR is permanently implemented for this device by the manufacturer. The specific manufacturer target MPR is indicated alongside the SAR results. MPR is enabled for this device, according to 3GPP TS36.101 Section 6.2.3 – 6.2.5 under Table 6.2.3-1.
- A-MPR was disabled for all SAR tests by setting NS=01 on the base station simulator. SAR tests were performed with the same number of RB and RB offsets transmitting on all TTI frames (maximum TTI).

|                                   |   |                               |   |                                 |
|-----------------------------------|---|-------------------------------|---|---------------------------------|
| FCC ID: ACJEB3910A                |  | SAR EVALUATION REPORT         |  | Reviewed by:<br>Quality Manager |
| Document S/N:<br>0Y1510271888.ACJ | Test Dates:<br>10/28/15 - 11/03/15  | DUT Type:<br>Portable Handset |   | Page 23 of 31                   |

# 12 FCC MULTI-TX AND ANTENNA SAR CONSIDERATIONS

## 12.1 Introduction

The following procedures adopted from FCC KDB Publication 447498 D01v05r02 are applicable to devices with built-in unlicensed transmitters such as 802.11 and Bluetooth devices which may simultaneously transmit with the licensed transmitter.

## 12.2 Simultaneous Transmission Procedures

This device contains transmitters that may operate simultaneously. Therefore simultaneous transmission analysis is required. Per FCC KDB 447498 D01v05r02 IV.C.1.iii and IEEE 1528-2013 Section 6.3.4.1.2, simultaneous transmission SAR test exclusion may be applied when the sum of the 1-g SAR for all the simultaneous transmitting antennas in a specific physical test configuration is  $\leq 1.6$  W/kg. The different test positions in an exposure condition may be considered collectively to determine SAR test exclusion according to the sum of 1-g or 10-g SAR.

When standalone SAR is not required to be measured, per FCC KDB 447498 D01v05r02 4.3.2.2), the following equation must be used to estimate the standalone 1g SAR and 10g SAR respectively for simultaneous transmission assessment involving that transmitter.

$$\text{Estimated SAR} = \frac{\sqrt{f(\text{GHz})}}{7.5} * \frac{(\text{Max Power of channel, mW})}{\text{Min. Separation Distance, mm}}$$

$$\text{Estimated SAR} = \frac{\sqrt{f(\text{GHz})}}{18.75} * \frac{(\text{Max Power of channel, mW})}{\text{Min. Separation Distance, mm}}$$

Note: Please see RF Exposure Technical Reports S/N: 0Y1312092376-R1.ACJ with simultaneous SAR assessments for the other combinations not referred to in these tables. This report only contains the combinations applicable to this permissive change.

## 12.3 Head SAR Simultaneous Transmission Analysis



**Table 12-1**  
**Simultaneous Transmission Scenario with 2.4 GHz WLAN (Held to Ear)**

| Exposure Condition | Mode             | 4G SAR (W/kg) | 2.4 GHz WLAN SAR (W/kg) | Σ SAR (W/kg) |
|--------------------|------------------|---------------|-------------------------|--------------|
| Head SAR           | LTE Band 4 (AWS) | 0.561         | 0.052                   | 0.613        |

## 12.4 Body-Worn Simultaneous Transmission Analysis

**Table 12-2**  
**Simultaneous Transmission Scenario with 2.4 GHz WLAN**

| Exposure Condition | Mode             | 4G SAR (W/kg) | 2.4 GHz WLAN SAR (W/kg) | Σ SAR (W/kg) |
|--------------------|------------------|---------------|-------------------------|--------------|
| Body-Worn          | LTE Band 4 (AWS) | 0.281         | 0.186                   | 0.467        |

|                                   |   |                               |   |                                 |
|-----------------------------------|---|-------------------------------|---|---------------------------------|
| FCC ID: ACJEB3910A                |  | SAR EVALUATION REPORT         |  | Reviewed by:<br>Quality Manager |
| Document S/N:<br>0Y1510271888.ACJ | Test Dates:<br>10/28/15 - 11/03/15  | DUT Type:<br>Portable Handset |   | Page 24 of 31                   |

**Table 12-3  
Simultaneous Transmission Scenario with Bluetooth**

| Exposure Condition | Mode             | 4G SAR (W/kg) | Bluetooth SAR (W/kg) | Σ SAR (W/kg) |
|--------------------|------------------|---------------|----------------------|--------------|
| Body-Worn          | LTE Band 4 (AWS) | 0.281         | 0.208                | 0.489        |

Estimated Bluetooth SAR results without the accessory were used in the above table to determine simultaneous transmission SAR test compliance since these results were higher than measured Bluetooth SAR with the accessory.

## 12.5 Hotspot SAR Simultaneous Transmission Analysis

**Table 12-4  
Simultaneous Transmission Scenario (2.4 GHz Hotspot at 1.0 cm)**

| Exposure Condition | Mode             | 4G SAR (W/kg) | 2.4 GHz WLAN SAR (W/kg) | Σ SAR (W/kg) |
|--------------------|------------------|---------------|-------------------------|--------------|
| Hotspot SAR        | LTE Band 4 (AWS) | 0.687         | 0.186                   | 0.873        |

## 12.6 Extremity SAR Simultaneous Transmission Analysis

**Table 12-5  
Simultaneous Transmission Scenario with 2.4 GHz WLAN (Hand Strap Accessory)**

| Exposure Condition | Mode             | 4G SAR (W/kg) | 2.4 GHz WLAN SAR (W/kg) | Σ SAR (W/kg) |
|--------------------|------------------|---------------|-------------------------|--------------|
| Extremity SAR      | LTE Band 4 (AWS) | 0.294         | 0.148                   | 0.442        |



**Table 12-6  
Simultaneous Transmission Scenario with Bluetooth (Hand Strap Accessory)**

| Exposure Condition | Mode             | 4G SAR (W/kg) | Bluetooth SAR (W/kg) | Σ SAR (W/kg) |
|--------------------|------------------|---------------|----------------------|--------------|
| Extremity SAR      | LTE Band 4 (AWS) | 0.294         | 0.167                | 0.461        |

Bluetooth SAR was not required to be measured for the extremity configuration per FCC KDB 447498. Estimated SAR results were used in the above table to determine simultaneous transmission SAR test exclusion.

## 12.7 Simultaneous Transmission Conclusion

The above numerical summed SAR results for all the worst-case simultaneous transmission conditions were below the SAR limit. Therefore, the above analysis is sufficient to determine that simultaneous transmission cases will not exceed the SAR limit and therefore no measured volumetric simultaneous SAR summation is required per FCC KDB Publication 447498 D01v05r02 and IEEE 1528-2013 Section 6.3.4.1.2.

|  |   |                                      |   |  |
|--|---|--------------------------------------|---|--|
| FCC ID: ACJEB3910A                       |  <b>PCTEST</b><br>ENGINEERING LABORATORY, INC. | <b>SAR EVALUATION REPORT</b>         |  | <b>Reviewed by:</b><br>Quality Manager |
| <b>Document S/N:</b><br>0Y1510271888.ACJ | <b>Test Dates:</b><br>10/28/15 - 11/03/15   | <b>DUT Type:</b><br>Portable Handset |   | Page 25 of 31                          |



## 13 SAR MEASUREMENT VARIABILITY

### 13.1 Measurement Variability

Per FCC KDB Publication 865664 D01v01, SAR measurement variability is required when the measured 1g SAR of a frequency band is  $>0.8$  W/kg and 10g SAR of a frequency band is  $>2.0$  W/kg. Since the measured 1g SAR results for all frequency bands was  $<0.8$  W/kg and 10g SAR results for all frequency bands was  $<2.0$  W/kg, measurement variability was not assessed.

### 13.2 Measurement Uncertainty

The measured SAR was  $<1.5$  W/kg for all frequency bands. Therefore, per KDB Publication 865664 D01v01r04, the extended measurement uncertainty analysis per IEEE 1528-2003 was not required.



|                                   |   |                               |   |                                 |
|-----------------------------------|---|-------------------------------|---|---------------------------------|
| FCC ID: ACJEB3910A                |  <b>PCTEST</b><br>ENGINEERING LABORATORY, INC. | SAR EVALUATION REPORT         |  | Reviewed by:<br>Quality Manager |
| Document S/N:<br>0Y1510271888.ACJ | Test Dates:<br>10/28/15 - 11/03/15  | DUT Type:<br>Portable Handset |   | Page 26 of 31                   |

# 14 EQUIPMENT LIST

| Manufacturer       | Model         | Description                                   | Cal Date   | Cal Interval | Cal Due    | Serial Number |
|--------------------|---------------|---|------------|--------------|------------|---------------|
| Agilent            | 8648D         | (9kHz-4GHz) Signal Generator                  | 3/15/2015  | Annual       | 3/15/2016  | 3629U00687    |
| Agilent            | 8753E         | (30kHz-6GHz) Network Analyzer                 | 12/30/2014 | Annual       | 12/30/2015 | JP38020182    |
| Agilent            | 8753ES        | Network Analyzer                              | 3/20/2015  | Annual       | 3/20/2016  | MY40001472    |
| Agilent            | E4438C        | ESG Vector Signal Generator                   | 3/15/2015  | Annual       | 3/15/2016  | MY45091346    |
| Agilent            | E4438C        | ESG Vector Signal Generator                   | 4/1/2014   | Biennial     | 4/1/2016   | MY47270002    |
| Agilent            | N5182A        | MXG Vector Signal Generator                   | 3/16/2015  | Annual       | 3/16/2016  | MY47420651    |
| Agilent            | N5182A        | MXG Vector Signal Generator                   | 3/16/2015  | Annual       | 3/16/2016  | MY47420800    |
| Amplifier Research | 15S1G6        | Amplifier                                     | CBT        | N/A          | CBT        | 433971        |
| Amplifier Research | 15S1G6        | Amplifier                                     | CBT        | N/A          | CBT        | 433978        |
| Anritsu            | MA24106A      | USB Power Sensor                              | 5/29/2015  | Annual       | 5/29/2016  | 1231535       |
| Anritsu            | MA24106A      | USB Power Sensor                              | 5/29/2015  | Annual       | 5/29/2016  | 1231538       |
| Anritsu            | MT8820C       | Radio Communication Analyzer                  | 7/24/2015  | Annual       | 7/24/2016  | 6200901190    |
| Anritsu            | MT8820C       | Radio Communication Analyzer                  | 9/1/2015   | Annual       | 9/1/2016   | 6201144419    |
| Anritsu            | MT8820C       | Radio Communication Analyzer                  | 6/12/2015  | Annual       | 6/12/2016  | 6201240328    |
| Anritsu            | MT8820C       | Radio Communication Analyzer                  | 11/18/2014 | Annual       | 11/18/2015 | 6201300731    |
| COMTech            | AR85729-5     | Solid State Amplifier                         | CBT        | N/A          | CBT        | M1S5A00-009   |
| Control Company    | 4040          | Digital Thermometer                           | 3/18/2015  | Biennial     | 3/18/2017  | 150194895     |
| Fisher Scientific  | S407993       | Long Stem Thermometer                         | 11/4/2013  | Biennial     | 11/4/2015  | 130671826     |
| Keysight           | 772D          | Dual Directional Coupler                      | CBT        | N/A          | CBT        | MY52180215    |
| MCL                | BW-N6W5+      | 6dB Attenuator                                | CBT        | N/A          | CBT        | 1139          |
| MiniCircuits       | SLP-2400+     | Low Pass Filter                               | CBT        | N/A          | CBT        | R8979500903   |
| Mini-Circuits      | BW-N20W5      | Power Attenuator                              | CBT        | N/A          | CBT        | 1226          |
| Mini-Circuits      | BW-N20W5+     | DC to 18 GHz Precision Fixed 20 dB Attenuator | CBT        | N/A          | CBT        | N/A           |
| Mini-Circuits      | NLP-2950+     | Low Pass Filter DC to 2700 MHz                | CBT        | N/A          | CBT        | N/A           |
| Mitutoyo           | CD-6"CSX      | Digital Caliper                               | 5/8/2014   | Biennial     | 5/8/2016   | 13264162      |
| Narda              | 4014C-6       | 4 - 8 GHz SMA 6 dB Directional Coupler        | CBT        | N/A          | CBT        | N/A           |
| Narda              | 4772-3        | Attenuator (3dB)                              | CBT        | N/A          | CBT        | 9406          |
| Pasternack         | NC-100        | Torque Wrench                                 | 5/21/2015  | Biennial     | 5/21/2017  | N/A           |
| Pasternack         | PE2208-6      | Bidirectional Coupler                         | CBT        | N/A          | CBT        | N/A           |
| Rohde & Schwarz    | CMW500        | Radio Communication Tester                    | 10/21/2015 | Annual       | 10/21/2016 | 102060        |
| Rohde & Schwarz    | CMW500        | Radio Communication Tester                    | 7/9/2015   | Annual       | 7/9/2016   | 106578        |
| Seekonk            | NC-100        | Torque Wrench                                 | 3/18/2014  | Biennial     | 3/18/2016  | 22313         |
| SPEAG              | D1750V2       | 1750 MHz SAR Dipole                           | 4/15/2015  | Annual       | 4/15/2016  | 1051          |
| SPEAG              | DAE4          | Dasy Data Acquisition Electronics             | 6/17/2015  | Annual       | 6/17/2016  | 859           |
| SPEAG              | DAE4          | Dasy Data Acquisition Electronics             | 4/20/2015  | Annual       | 4/20/2016  | 1407          |
| SPEAG              | DAK-3.5       | Dielectric Assessment Kit                     | 5/12/2015  | Annual       | 5/12/2016  | 1070          |
| SPEAG              | DAKS_VNA R140 | VNA for Portable DAK                          | 8/16/2015  | Annual       | 8/16/2016  | 80513         |
| SPEAG              | ES3DV3        | SAR Probe                                     | 1/20/2015  | Annual       | 1/20/2016  | 3213          |
| SPEAG              | ES3DV3        | SAR Probe                                     | 5/20/2015  | Annual       | 5/20/2016  | 3263          |
| SPEAG              | Planar R140   | Reflectometer                                 | 8/2/2015   | Annual       | 8/2/2016   | 50513         |

Note:



1. CBT (Calibrated Before Testing). Prior to testing, the measurement paths containing a cable, amplifier, attenuator, coupler or filter were connected to a calibrated source (i.e. a signal generator) to determine the losses of the measurement path. The power meter offset was then adjusted to compensate for the measurement system losses. This level offset is stored within the power meter before measurements are made. This calibration verification procedure applies to the system verification and output power measurements. The calibrated reading is then taken directly from the power meter after compensation of the losses for all final power measurements.
2. All equipment was used within its calibration period.

|                                   |  |                               |                                 |
|-----------------------------------|--|-------------------------------|---------------------------------|
| FCC ID: ACJEB3910A                |  <b>SAR EVALUATION REPORT</b>  |                               | Reviewed by:<br>Quality Manager |
| Document S/N:<br>0Y1510271888.ACJ | Test Dates:<br>10/28/15 - 11/03/15   | DUT Type:<br>Portable Handset | Page 27 of 31                   |

# 15 MEASUREMENT UNCERTAINTIES

| a   | b              | c          | d           | e=<br>f(d,k) | f                  | g                     | h =<br>c x f/e           | i =<br>c x g/e             | k              |     |
|---|----------------|------------|-------------|--------------|--------------------|-----------------------|--------------------------|----------------------------|----------------|-----|
| Uncertainty Component   | IEEE 1528 Sec. | Tol. (± %) | Prob. Dist. | Div.         | c <sub>i</sub> 1gm | c <sub>i</sub> 10 gms | 1gm u <sub>i</sub> (± %) | 10gms u <sub>i</sub> (± %) | v <sub>i</sub> |     |
| <b>Measurement System</b>   |                |            |             |              |                    |                       |                          |                            |                |     |
| Probe Calibration   | E.2.1          | 6.0        | N           | 1            | 1.0                | 1.0                   | 6.0                      | 6.0                        | ∞              |     |
| Axial Isotropy  | E.2.2          | 0.25       | N           | 1            | 0.7                | 0.7                   | 0.2                      | 0.2                        | ∞              |     |
| Hemishperical Isotropy  | E.2.2          | 1.3        | N           | 1            | 1.0                | 1.0                   | 1.3                      | 1.3                        | ∞              |     |
| Boundary Effect   | E.2.3          | 0.4        | N           | 1            | 1.0                | 1.0                   | 0.4                      | 0.4                        | ∞              |     |
| Linearity   | E.2.4          | 0.3        | N           | 1            | 1.0                | 1.0                   | 0.3                      | 0.3                        | ∞              |     |
| System Detection Limits   | E.2.5          | 5.1        | N           | 1            | 1.0                | 1.0                   | 5.1                      | 5.1                        | ∞              |     |
| Readout Electronics   | E.2.6          | 1.0        | N           | 1            | 1.0                | 1.0                   | 1.0                      | 1.0                        | ∞              |     |
| Response Time   | E.2.7          | 0.8        | R           | 1.73         | 1.0                | 1.0                   | 0.5                      | 0.5                        | ∞              |     |
| Integration Time  | E.2.8          | 2.6        | R           | 1.73         | 1.0                | 1.0                   | 1.5                      | 1.5                        | ∞              |     |
| RF Ambient Conditions   | E.6.1          | 3.0        | R           | 1.73         | 1.0                | 1.0                   | 1.7                      | 1.7                        | ∞              |     |
| Probe Positioner Mechanical Tolerance   | E.6.2          | 0.4        | R           | 1.73         | 1.0                | 1.0                   | 0.2                      | 0.2                        | ∞              |     |
| Probe Positioning w/ respect to Phantom                                       | E.6.3          | 2.9        | R           | 1.73         | 1.0                | 1.0                   | 1.7                      | 1.7                        | ∞              |     |
| Extrapolation, Interpolation & Integration algorithms for Max. SAR Evaluation | E.5            | 1.0        | R           | 1.73         | 1.0                | 1.0                   | 0.6                      | 0.6                        | ∞              |     |
| <b>Test Sample Related</b>  |                |            |             |              |                    |                       |                          |                            |                |     |
| Test Sample Positioning   | E.4.2          | 6.0        | N           | 1            | 1.0                | 1.0                   | 6.0                      | 6.0                        | 287            |     |
| Device Holder Uncertainty   | E.4.1          | 3.32       | R           | 1.73         | 1.0                | 1.0                   | 1.9                      | 1.9                        | ∞              |     |
| Output Power Variation - SAR drift measurement                                | 6.6.2          | 5.0        | R           | 1.73         | 1.0                | 1.0                   | 2.9                      | 2.9                        | ∞              |     |
| <b>Phantom &amp; Tissue Parameters</b>  |                |            |             |              |                    |                       |                          |                            |                |     |
| Phantom Uncertainty (Shape & Thickness tolerances)                            | E.3.1          | 4.0        | R           | 1.73         | 1.0                | 1.0                   | 2.3                      | 2.3                        | ∞              |     |
| Liquid Conductivity - deviation from target values                            | E.3.2          | 5.0        | R           | 1.73         | 0.64               | 0.43                  | 1.8                      | 1.2                        | ∞              |     |
| Liquid Conductivity - measurement uncertainty                                 | E.3.3          | 3.8        | N           | 1            | 0.64               | 0.43                  | 2.4                      | 1.6                        | 6              |     |
| Liquid Permittivity - deviation from target values                            | E.3.2          | 5.0        | R           | 1.73         | 0.60               | 0.49                  | 1.7                      | 1.4                        | ∞              |     |
| Liquid Permittivity - measurement uncertainty                                 | E.3.3          | 4.5        | N           | 1            | 0.60               | 0.49                  | 2.7                      | 2.2                        | 6              |     |
| <b>Combined Standard Uncertainty (k=1)</b>                                    |                |            |             |              |                    |                       | RSS                      | 12.1                       | 11.7           | 299 |
| <b>Expanded Uncertainty (95% CONFIDENCE LEVEL)</b>                            |                |            |             |              |                    |                       | k=2                      | 24.2                       | 23.5           |     |

The above measurement uncertainties are according to IEEE Std. 1528-2003



|                                   |   |                               |   |                                 |
|-----------------------------------|---|-------------------------------|---|---------------------------------|
| FCC ID: ACJEB3910A                |  | SAR EVALUATION REPORT         |  | Reviewed by:<br>Quality Manager |
| Document S/N:<br>0Y1510271888.ACJ | Test Dates:<br>10/28/15 - 11/03/15  | DUT Type:<br>Portable Handset |   | Page 28 of 31                   |

## 16 CONCLUSION

### 16.1 Measurement Conclusion



The SAR evaluation indicates that the EUT complies with the RF radiation exposure limits of the FCC and Industry Canada, with respect to all parameters subject to this test. These measurements were taken to simulate the RF effects of RF exposure under worst-case conditions. Precise laboratory measures were taken to assure repeatability of the tests. The results and statements relate only to the item(s) tested.

Please note that the absorption and distribution of electromagnetic energy in the body are very complex phenomena that depend on the mass, shape, and size of the body, the orientation of the body with respect to the field vectors, and the electrical properties of both the body and the environment. Other variables that may play a substantial role in possible biological effects are those that characterize the environment (e.g. ambient temperature, air velocity, relative humidity, and body insulation) and those that characterize the individual (e.g. age, gender, activity level, debilitation, or disease). Because various factors may interact with one another to vary the specific biological outcome of an exposure to electromagnetic fields, any protection guide should consider maximal amplification of biological effects as a result of field-body interactions, environmental conditions, and physiological variables. [3]



|                                   |   |                               |   |                                 |
|-----------------------------------|---|-------------------------------|---|---------------------------------|
| FCC ID: ACJEB3910A                |  <b>PCTEST</b><br>ENGINEERING LABORATORY, INC. | SAR EVALUATION REPORT         |  | Reviewed by:<br>Quality Manager |
| Document S/N:<br>0Y1510271888.ACJ | Test Dates:<br>10/28/15 - 11/03/15  | DUT Type:<br>Portable Handset |   | Page 29 of 31                   |

## 17 REFERENCES

- [1] Federal Communications Commission, ET Docket 93-62, Guidelines for Evaluating the Environmental Effects of Radiofrequency Radiation, Aug. 1996.
- [2] ANSI/IEEE C95.1-2005, American National Standard safety levels with respect to human exposure to radio frequency electromagnetic fields, 3kHz to 300GHz, New York: IEEE, 2006.
- [3] ANSI/IEEE C95.1-1992, American National Standard safety levels with respect to human exposure to radio frequency electromagnetic fields, 3kHz to 300GHz, New York: IEEE, Sept. 1992.
- [4] ANSI/IEEE C95.3-2002, IEEE Recommended Practice for the Measurement of Potentially Hazardous Electromagnetic Fields - RF and Microwave, New York: IEEE, December 2002.
- [5] IEEE Standards Coordinating Committee 39 –Standards Coordinating Committee 34 – IEEE Std. 1528-2003, Recommended Practice for Determining the Peak Spatial-Average Specific Absorption Rate (SAR) in the Human Head Due to Wireless Communications Devices: Measurement Techniques.
- [6] NCRP, National Council on Radiation Protection and Measurements, Biological Effects and Exposure Criteria for RadioFrequency Electromagnetic Fields, NCRP Report No. 86, 1986. Reprinted Feb. 1995.
- [7] T. Schmid, O. Egger, N. Kuster, Automated E-field scanning system for dosimetric assessments, IEEE Transaction on Microwave Theory and Techniques, vol. 44, Jan. 1996, pp. 105-113.
- [8] K. Pokovic, T. Schmid, N. Kuster, Robust setup for precise calibration of E-field probes in tissue simulating liquids at mobile communications frequencies, ICECOM97, Oct. 1997, pp. 1 -124.
- [9] K. Pokovic, T. Schmid, and N. Kuster, E-field Probe with improved isotropy in brain simulating liquids, Proceedings of the ELMAR, Zadar, Croatia, June 23-25, 1996, pp. 172-175.
- [10] Schmid & Partner Engineering AG, Application Note: Data Storage and Evaluation, June 1998, p2.
- [11] V. Hombach, K. Meier, M. Burkhardt, E. Kuhn, N. Kuster, The Dependence of EM Energy Absorption upon Human Modeling at 900 MHz, IEEE Transaction on Microwave Theory and Techniques, vol. 44 no. 10, Oct. 1996, pp. 1865-1873.
- [12] N. Kuster and Q. Balzano, Energy absorption mechanism by biological bodies in the near field of dipole antennas above 300MHz, IEEE Transaction on Vehicular Technology, vol. 41, no. 1, Feb. 1992, pp. 17-23.
- [13] G. Hartsgrove, A. Kraszewski, A. Surowiec, Simulated Biological Materials for Electromagnetic Radiation Absorption Studies, University of Ottawa, Bioelectromagnetics, Canada: 1987, pp. 29-36.
- [14] Q. Balzano, O. Garay, T. Manning Jr., Electromagnetic Energy Exposure of Simulated Users of Portable Cellular Telephones, IEEE Transactions on Vehicular Technology, vol. 44, no.3, Aug. 1995.
- [15] W. Gander, Computermathematick, Birkhaeuser, Basel, 1992.
- [16] W.H. Press, S.A. Teukolsky, W.T. Vetterling, and B.P. Flannery, Numerical Recipes in C, The Art of Scientific Computing, Second edition, Cambridge University Press, 1992.
- [17] N. Kuster, R. Kastle, T. Schmid, Dosimetric evaluation of mobile communications equipment with known precision, IEEE Transaction on Communications, vol. E80-B, no. 5, May 1997, pp. 645-652.

|  |   |                                      |   |  |
|--|---|--------------------------------------|---|--|
| FCC ID: ACJEB3910A                       |  <b>PCTEST</b><br>ENGINEERING LABORATORY, INC. | <b>SAR EVALUATION REPORT</b>         |  | <b>Reviewed by:</b><br>Quality Manager |
| <b>Document S/N:</b><br>0Y1510271888.ACJ | <b>Test Dates:</b><br>10/28/15 - 11/03/15   | <b>DUT Type:</b><br>Portable Handset | Page 30 of 31   |  |

- [18] CENELEC CLC/SC111B, European Prestandard (prENV 50166-2), Human Exposure to Electromagnetic Fields High-frequency: 10kHz-300GHz, Jan. 1995.
- [19] Prof. Dr. Niels Kuster, ETH, Eidgenössische Technische Hochschule Zürich, Dosimetric Evaluation of the Cellular Phone.
- [20] IEC 62209-1, Human exposure to radio frequency fields from hand-held and body-mounted wireless communication devices - Human models, instrumentation, and procedures - Part 1: Procedure to determine the specific absorption rate (SAR) for hand-held devices used in close proximity to the ear (frequency range of 300 MHz to 3 GHz), Feb. 2005.
- [21] Industry Canada RSS-102 Radio Frequency Exposure Compliance of Radiocommunication Apparatus (All Frequency Bands) Issue 4, March 2010.
- [22] Health Canada Safety Code 6 Limits of Human Exposure to Radio Frequency Electromagnetic Fields in the Frequency Range from 3 kHz – 300 GHz, 2009
- [23] FCC SAR Test Procedures for 2G-3G Devices, Mobile Hotspot and UMPC Devices KDB Publications 941225, D01-D07
- [24] SAR Measurement Guidance for IEEE 802.11 Transmitters, KDB Publication 248227 D01v02r01
- [25] FCC SAR Considerations for Handsets with Multiple Transmitters and Antennas, KDB Publications 648474 D03-D04
- [26] FCC SAR Evaluation Considerations for Laptop, Notebook, Netbook and Tablet Computers, FCC KDB Publication 616217 D04
- [27] FCC SAR Measurement and Reporting Requirements for 100MHz – 6 GHz, KDB Publications 865664 D01-D02
- [28] FCC General RF Exposure Guidance and SAR Procedures for Dongles, KDB Publication 447498, D01-D02
- [29] Anexo à Resolução No. 533, de 10 de Setembro de 2009.
- [30] IEC 62209-2, Human exposure to radio frequency fields from hand-held and body-mounted wireless communication devices - Human models, instrumentation, and procedures - Part 2: Procedure to determine the specific absorption rate (SAR) for wireless communication devices used in close proximity to the human body (frequency range of 30 MHz to 6 GHz), Mar. 2010.

|  |  |                                      |  |
|--|--|--------------------------------------|--|
| FCC ID: ACJEB3910A                       |  <b>SAR EVALUATION REPORT</b>  |                                      | <b>Reviewed by:</b><br>Quality Manager |
| <b>Document S/N:</b><br>0Y1510271888.ACJ | <b>Test Dates:</b><br>10/28/15 - 11/03/15  | <b>DUT Type:</b><br>Portable Handset | Page 31 of 31                          |

## APPENDIX A: SAR TEST DATA

# PCTEST ENGINEERING LABORATORY, INC.

**DUT: ACJEB3910A; Type: Portable Handset; Serial: 22046**

Communication System: UID 0, LTE Band 4 (AWS); Frequency: 1732.5 MHz; Duty Cycle: 1:1  
Medium: 1750 Head, Medium parameters used (interpolated):  
 $f = 1732.5 \text{ MHz}$ ;  $\sigma = 1.331 \text{ S/m}$ ;  $\epsilon_r = 38.676$ ;  $\rho = 1000 \text{ kg/m}^3$   
Phantom section: Left Section

Test Date: 11-03-2015; Ambient Temp: 22.4°C; Tissue Temp: 22.7°C

Probe: ES3DV3 - SN3213; ConvF(5.22, 5.22, 5.22); Calibrated: 1/20/2015;  
Sensor-Surface: 3mm (Mechanical Surface Detection)  
Electronics: DAE4 Sn1407; Calibrated: 4/20/2015  
Phantom: SAM Front; Type: QD000P40CD; Serial: TP:1758  
Measurement SW: DASYS2, Version 52.8 (8); SEMCAD X Version 14.6.10 (7331)

**Mode: LTE Band 4 (AWS), Left Head, Cheek, Mid.ch,  
20 MHz Bandwidth, QPSK, 1 RB, 0 RB Offset**

**Area Scan (9x15x1):** Measurement grid: dx=15mm, dy=15mm  
**Zoom Scan (5x5x7)/Cube 0:** Measurement grid: dx=8mm, dy=8mm, dz=5mm  
Reference Value = 20.50 V/m; Power Drift = 0.01 dB  
Peak SAR (extrapolated) = 0.737 W/kg  
**SAR(1 g) = 0.500 W/kg**

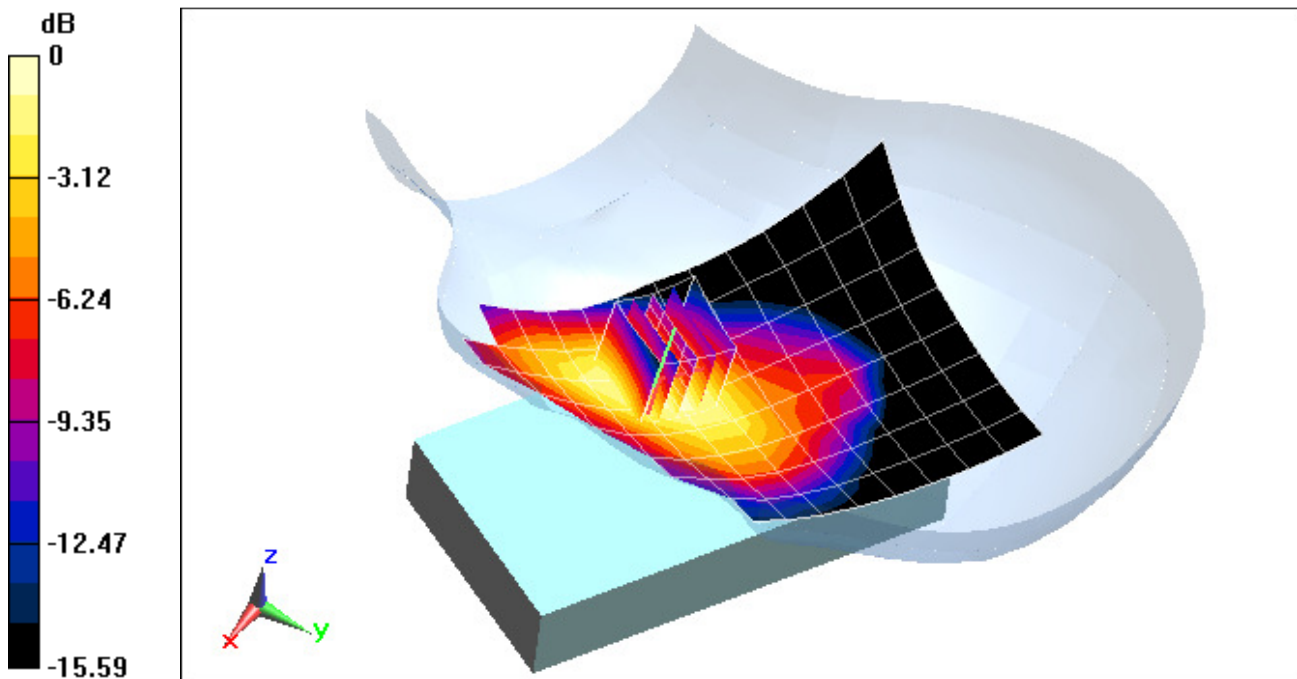

0 dB = 0.580 W/kg = -2.37 dBW/kg

# PCTEST ENGINEERING LABORATORY, INC.

**DUT: ACJEB3910A; Type: Portable Handset; Serial: 22046**

Communication System: UID 0, LTE Band 4 (AWS); Frequency: 1732.5 MHz; Duty Cycle: 1:1  
Medium: 1750 Body, Medium parameters used (interpolated):  
 $f = 1732.5 \text{ MHz}$ ;  $\sigma = 1.439 \text{ S/m}$ ;  $\epsilon_r = 51.836$ ;  $\rho = 1000 \text{ kg/m}^3$   
Phantom section: Flat Section; Space: 0.0 cm

Test Date: 10-28-2015; Ambient Temp: 22.3°C; Tissue Temp: 21.8°C

Probe: ES3DV3 - SN3263; ConvF(4.88, 4.88, 4.88); Calibrated: 5/20/2015;  
Sensor-Surface: 3mm (Mechanical Surface Detection)  
Electronics: DAE4 Sn859; Calibrated: 6/17/2015  
Phantom: SAM with CRP (Left); Type: SAM; Serial: 1715  
Measurement SW: DASY52, Version 52.8 (8); SEMCAD X Version 14.6.10 (7331)

**Mode: LTE Band 4 (AWS), Body SAR, Front Side, Mid.ch, 20 MHz Bandwidth,  
QPSK, 1 RB, 0 RB Offset, with Body Holster Accessory**

**Area Scan (10x15x1):** Measurement grid: dx=15mm, dy=15mm  
**Zoom Scan (5x5x7)/Cube 0:** Measurement grid: dx=8mm, dy=8mm, dz=5mm  
Reference Value = 13.71 V/m; Power Drift = 0.04 dB  
Peak SAR (extrapolated) = 0.387 W/kg  
**SAR(1 g) = 0.250 W/kg**

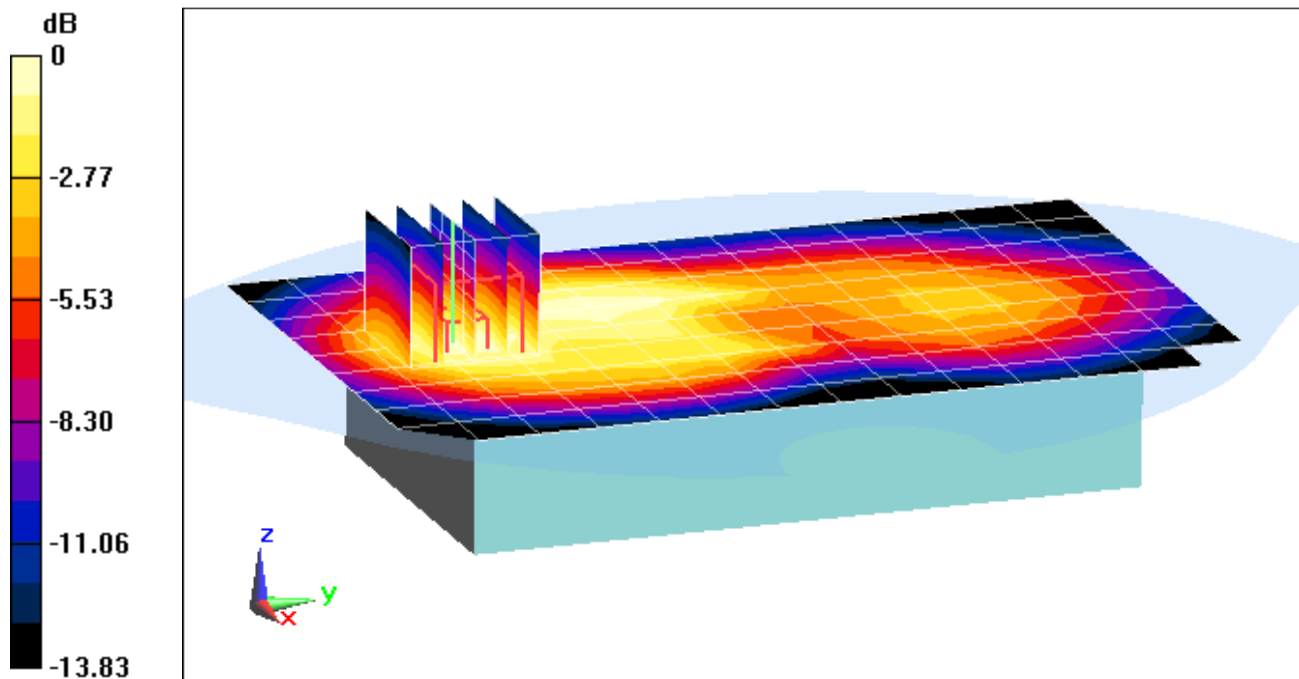

0 dB = 0.295 W/kg = -5.30 dBW/kg

# PCTEST ENGINEERING LABORATORY, INC.

**DUT: ACJEB3910A; Type: Portable Handset; Serial: 22046**

Communication System: UID 0, LTE Band 4 (AWS); Frequency: 1732.5 MHz; Duty Cycle: 1:1  
Medium: 1750 Body, Medium parameters used (interpolated):  
 $f = 1732.5 \text{ MHz}$ ;  $\sigma = 1.439 \text{ S/m}$ ;  $\epsilon_r = 51.836$ ;  $\rho = 1000 \text{ kg/m}^3$   
Phantom section: Flat Section; Space: 1.0 cm

Test Date: 10-28-2015; Ambient Temp: 22.3°C; Tissue Temp: 21.8°C

Probe: ES3DV3 - SN3263; ConvF(4.88, 4.88, 4.88); Calibrated: 5/20/2015;  
Sensor-Surface: 3mm (Mechanical Surface Detection)  
Electronics: DAE4 Sn859; Calibrated: 6/17/2015  
Phantom: SAM with CRP (Left); Type: SAM; Serial: 1715  
Measurement SW: DASY52, Version 52.8 (8); SEMCAD X Version 14.6.10 (7331)

**Mode: LTE Band 4 (AWS), Body SAR, Front Side, Mid.ch,  
20 MHz Bandwidth, QPSK, 1 RB, 0 RB Offset, without Accessory**

**Area Scan (10x15x1):** Measurement grid: dx=15mm, dy=15mm  
**Zoom Scan (5x5x7)/Cube 0:** Measurement grid: dx=8mm, dy=8mm, dz=5mm  
Reference Value = 21.96 V/m; Power Drift = 0.04 dB  
Peak SAR (extrapolated) = 0.996 W/kg  
**SAR(1 g) = 0.612 W/kg**

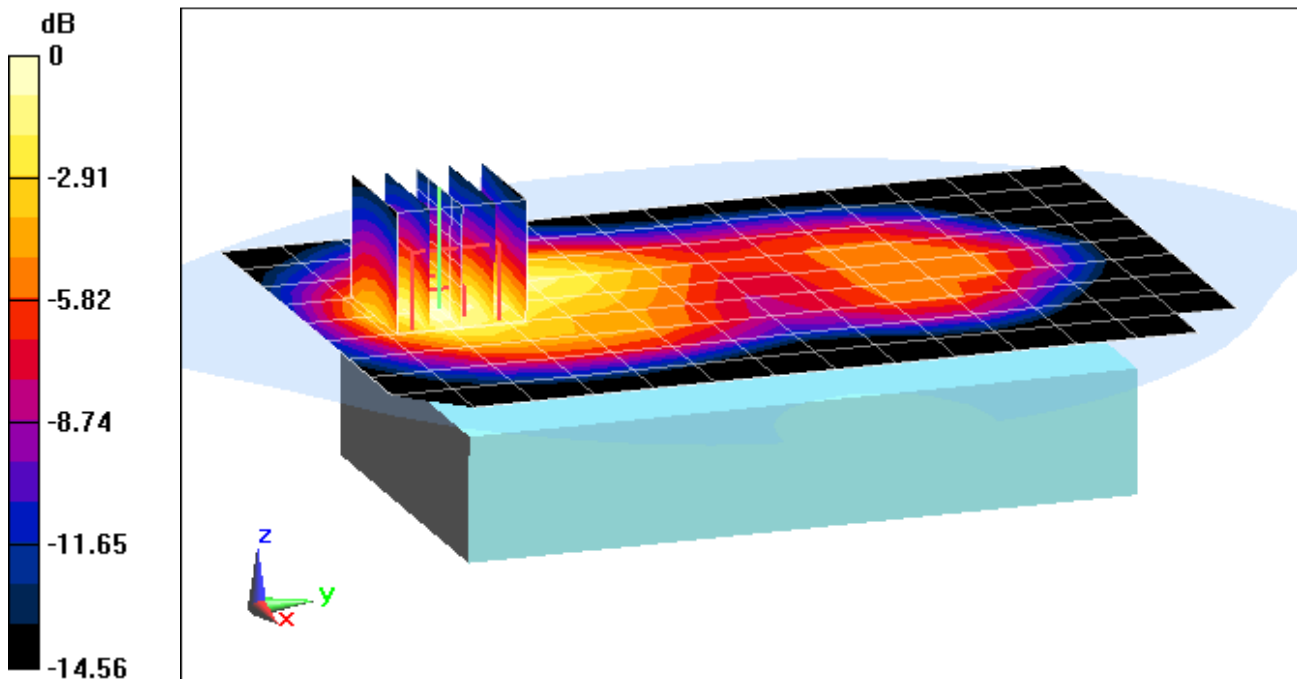

0 dB = 0.744 W/kg = -1.28 dBW/kg

# PCTEST ENGINEERING LABORATORY, INC.

**DUT: ACJEB3910A; Type: Portable Handset; Serial: 22046**

Communication System: UID 0, LTE Band 4 (AWS); Frequency: 1732.5 MHz; Duty Cycle: 1:1  
Medium: 1750 Body, Medium parameters used (interpolated):  
 $f = 1732.5 \text{ MHz}$ ;  $\sigma = 1.439 \text{ S/m}$ ;  $\epsilon_r = 51.836$ ;  $\rho = 1000 \text{ kg/m}^3$   
Phantom section: Flat Section; Space: 0.0 cm

Test Date: 10-28-2015; Ambient Temp: 22.3°C; Tissue Temp: 21.8°C

Probe: ES3DV3 - SN3263; ConvF(4.88, 4.88, 4.88); Calibrated: 5/20/2015;  
Sensor-Surface: 3mm (Mechanical Surface Detection)  
Electronics: DAE4 Sn859; Calibrated: 6/17/2015  
Phantom: SAM with CRP (Left); Type: SAM; Serial: 1715  
Measurement SW: DASY52, Version 52.8 (8); SEMCAD X Version 14.6.10 (7331)

**Mode: LTE Band 4 (AWS), Extremity SAR, Back Side, Mid.ch, 20 MHz Bandwidth,  
QPSK, 1 RB, 0 RB Offset, with Hand Strap Accessory, Top-Right**

**Area Scan (10x15x1):** Measurement grid: dx=15mm, dy=15mm  
**Zoom Scan (5x5x7)/Cube 0:** Measurement grid: dx=8mm, dy=8mm, dz=5mm  
Reference Value = 18.81 V/m; Power Drift = -0.05 dB  
Peak SAR (extrapolated) = 0.748 W/kg  
**SAR(10 g) = 0.262 W/kg**

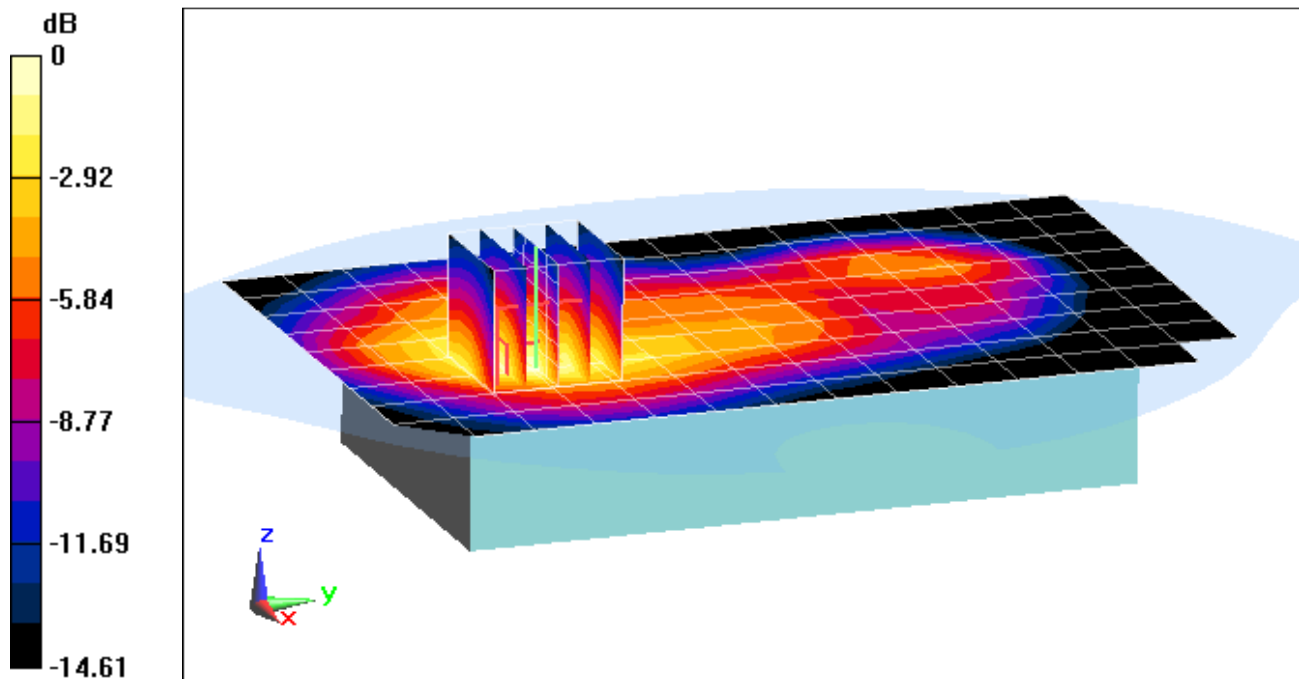

0 dB = 0.558 W/kg = -2.53 dBW/kg

## APPENDIX B: SYSTEM VERIFICATION

# PCTEST ENGINEERING LABORATORY, INC.

**DUT: Dipole 1750 MHz; Type: D1750V2; Serial: 1051**

Communication System: UID 0, CW; Frequency: 1750 MHz; Duty Cycle: 1:1

Medium: 1750 Head Medium parameters used:

$f = 1750 \text{ MHz}$ ;  $\sigma = 1.349 \text{ S/m}$ ;  $\epsilon_r = 38.601$ ;  $\rho = 1000 \text{ kg/m}^3$

Phantom section: Flat Section; Space: 1.0 cm

Test Date: 11-03-2015; Ambient Temp: 22.4°C; Tissue Temp: 22.7°C

Probe: ES3DV3 - SN3213; ConvF(5.22, 5.22, 5.22); Calibrated: 1/20/2015;

Sensor-Surface: 3mm (Mechanical Surface Detection)

Electronics: DAE4 Sn1407; Calibrated: 4/20/2015

Phantom: SAM Front; Type: QD000P40CD; Serial: TP:1758

Measurement SW: DASY52, Version 52.8 (8);SEMCAD X Version 14.6.10 (7331)

## 1750 MHz System Verification at 20.0 dBm (100 mW)

**Area Scan (7x9x1):** Measurement grid: dx=15mm, dy=15mm

**Zoom Scan (5x5x7)/Cube 0:** Measurement grid: dx=8mm, dy=8mm, dz=5mm

Peak SAR (extrapolated) = 6.44 W/kg

**SAR(1 g) = 3.59 W/kg**

Deviation(1 g) = -0.83%

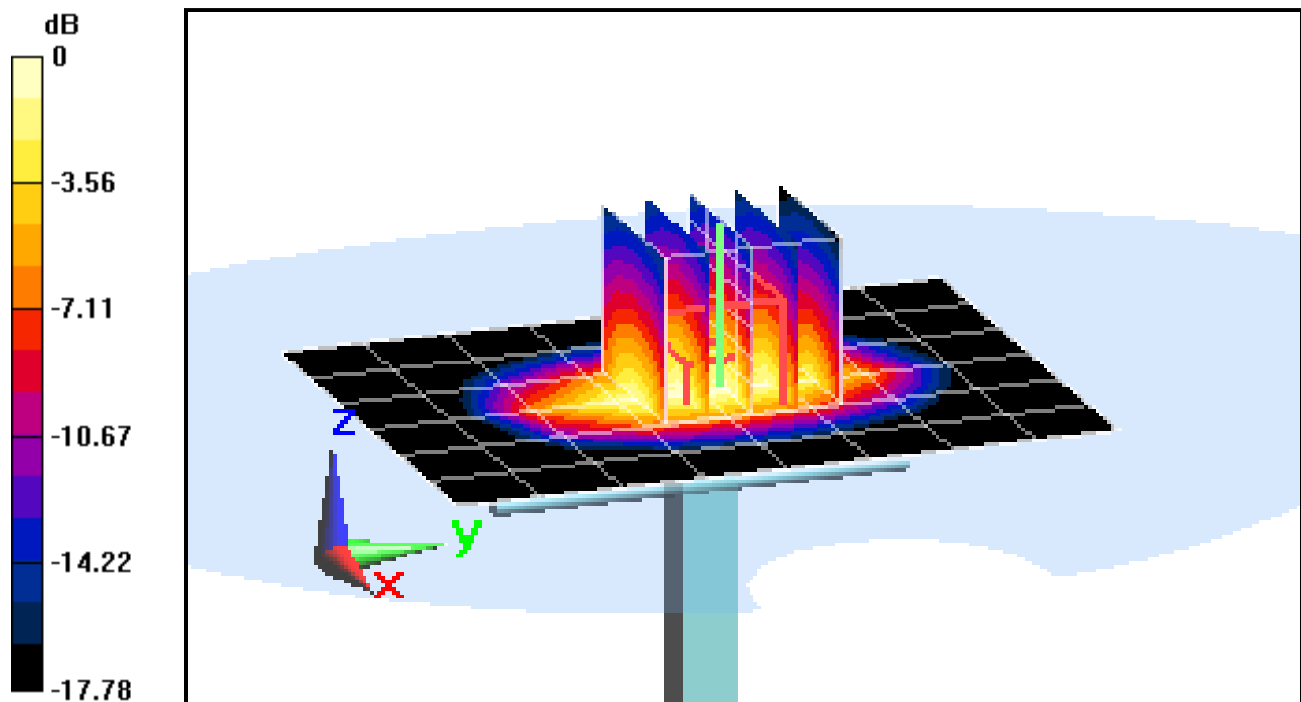

0 dB = 4.45 W/kg = 6.48 dBW/kg

# PCTEST ENGINEERING LABORATORY, INC.

**DUT: Dipole 1750 MHz; Type: D1750V2; Serial: 1051**

Communication System: UID 0, CW; Frequency: 1750 MHz; Duty Cycle: 1:1

Medium: 1750 Body Medium parameters used:

$f = 1750 \text{ MHz}$ ;  $\sigma = 1.457 \text{ S/m}$ ;  $\epsilon_r = 51.783$ ;  $\rho = 1000 \text{ kg/m}^3$

Phantom section: Flat Section; Space: 1.0 cm

Test Date: 10-28-2015; Ambient Temp: 22.3°C; Tissue Temp: 21.8°C

Probe: ES3DV3 - SN3263; ConvF(4.88, 4.88, 4.88); Calibrated: 5/20/2015;

Sensor-Surface: 3mm (Mechanical Surface Detection)

Electronics: DAE4 Sn859; Calibrated: 6/17/2015

Phantom: SAM with CRP (Left); Type: SAM; Serial: 1715

Measurement SW: DASY52, Version 52.8 (8);SEMCAD X Version 14.6.10 (7331)

## 1750 MHz System Verification at 20.0 dBm (100 mW)

**Area Scan (7x9x1):** Measurement grid: dx=15mm, dy=15mm

**Zoom Scan (5x6x7)/Cube 0:** Measurement grid: dx=8mm, dy=8mm, dz=5mm

Peak SAR (extrapolated) = 6.40 W/kg

**SAR(1 g) = 3.73 W/kg; SAR(10 g) = 2.01 W/kg**

Deviation(1 g) = 0.54%; Deviation(10 g) = 0.50%

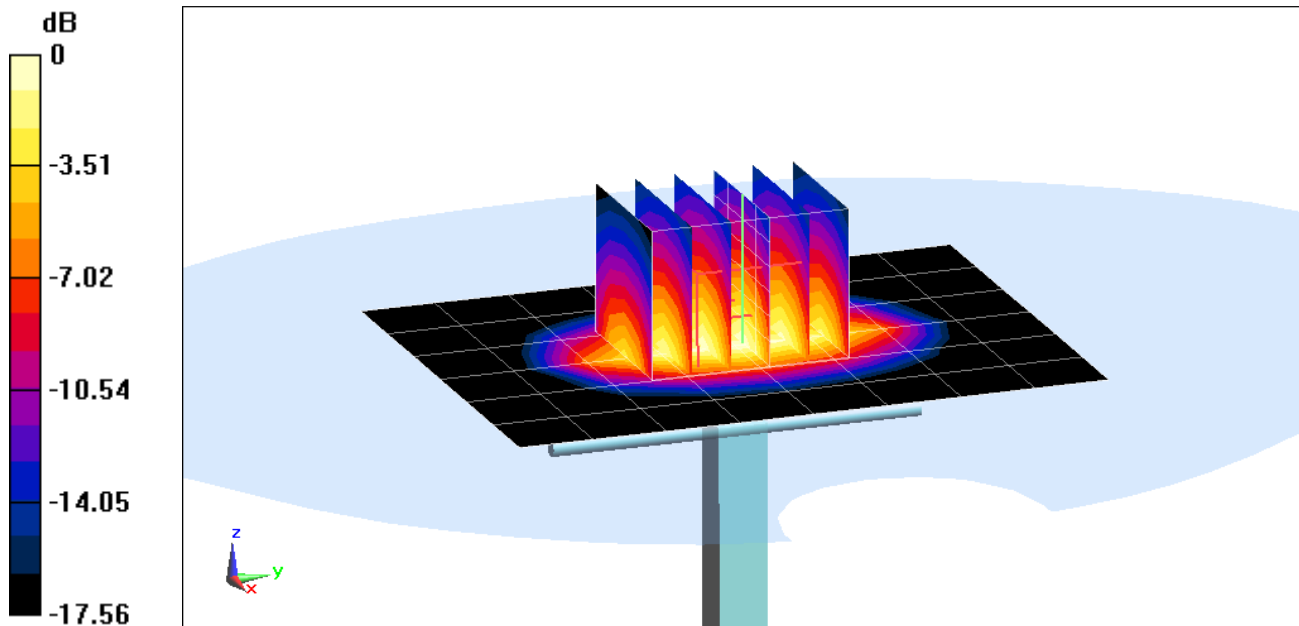

0 dB = 4.68 W/kg = 6.70 dBW/kg

## APPENDIX C: PROBE CALIBRATION



Accredited by the Swiss Accreditation Service (SAS)  
The Swiss Accreditation Service is one of the signatories to the EA  
Multilateral Agreement for the recognition of calibration certificates

Accreditation No.: **SCS 0108**

Client **PC Test**

Certificate No: **D1750V2-1051\_Apr15**

## CALIBRATION CERTIFICATE

Object **D1750V2 - SN:1051**

Calibration procedure(s) **QA CAL-05.v9  
Calibration procedure for dipole validation kits above 700 MHz**

PM ✓  
4/29/15

Calibration date: **April 15, 2015**

This calibration certificate documents the traceability to national standards, which realize the physical units of measurements (SI).  
The measurements and the uncertainties with confidence probability are given on the following pages and are part of the certificate.

All calibrations have been conducted in the closed laboratory facility: environment temperature (22 ± 3)°C and humidity < 70%.

Calibration Equipment used (M&TE critical for calibration)

| Primary Standards           | ID #               | Cal Date (Certificate No.)        | Scheduled Calibration  |
|-----------------------------|--------------------|-----------------------------------|------------------------|
| Power meter EPM-442A        | GB37480704         | 07-Oct-14 (No. 217-02020)         | Oct-15                 |
| Power sensor HP 8481A       | US37292783         | 07-Oct-14 (No. 217-02020)         | Oct-15                 |
| Power sensor HP 8481A       | MY41092317         | 07-Oct-14 (No. 217-02021)         | Oct-15                 |
| Reference 20 dB Attenuator  | SN: 5058 (20k)     | 01-Apr-15 (No. 217-02131)         | Mar-16                 |
| Type-N mismatch combination | SN: 5047.2 / 06327 | 01-Apr-15 (No. 217-02134)         | Mar-16                 |
| Reference Probe ES3DV3      | SN: 3205           | 30-Dec-14 (No. ES3-3205_Dec14)    | Dec-15                 |
| DAE4                        | SN: 601            | 18-Aug-14 (No. DAE4-601_Aug14)    | Aug-15                 |
| Secondary Standards         | ID #               | Check Date (in house)             | Scheduled Check        |
| RF generator R&S SMT-06     | 100005             | 04-Aug-99 (in house check Oct-13) | In house check: Oct-16 |
| Network Analyzer HP 8753E   | US37390585 S4206   | 18-Oct-01 (in house check Oct-14) | In house check: Oct-15 |

Calibrated by: **Jeton Kastrati**      Name: Jeton Kastrati      Function: Laboratory Technician      Signature:

Approved by: **Katja Pokovic**      Name: Katja Pokovic      Function: Technical Manager      Signature:

Issued: April 15, 2015

This calibration certificate shall not be reproduced except in full without written approval of the laboratory.



Accredited by the Swiss Accreditation Service (SAS)  
The Swiss Accreditation Service is one of the signatories to the EA  
Multilateral Agreement for the recognition of calibration certificates

Accreditation No.: **SCS 0108**

**Glossary:**

|       |                                 |
|-------|---------------------------------|
| TSL   | tissue simulating liquid        |
| ConvF | sensitivity in TSL / NORM x,y,z |
| N/A   | not applicable or not measured  |

**Calibration is Performed According to the Following Standards:**

- IEEE Std 1528-2013, "IEEE Recommended Practice for Determining the Peak Spatial-Averaged Specific Absorption Rate (SAR) in the Human Head from Wireless Communications Devices: Measurement Techniques", June 2013
- IEC 62209-1, "Procedure to measure the Specific Absorption Rate (SAR) for hand-held devices used in close proximity to the ear (frequency range of 300 MHz to 3 GHz)", February 2005
- KDB 865664, "SAR Measurement Requirements for 100 MHz to 6 GHz"

**Additional Documentation:**

- DASY4/5 System Handbook

**Methods Applied and Interpretation of Parameters:**

- Measurement Conditions:* Further details are available from the Validation Report at the end of the certificate. All figures stated in the certificate are valid at the frequency indicated.
- Antenna Parameters with TSL:* The dipole is mounted with the spacer to position its feed point exactly below the center marking of the flat phantom section, with the arms oriented parallel to the body axis.
- Feed Point Impedance and Return Loss:* These parameters are measured with the dipole positioned under the liquid filled phantom. The impedance stated is transformed from the measurement at the SMA connector to the feed point. The Return Loss ensures low reflected power. No uncertainty required.
- Electrical Delay:* One-way delay between the SMA connector and the antenna feed point. No uncertainty required.
- SAR measured:* SAR measured at the stated antenna input power.
- SAR normalized:* SAR as measured, normalized to an input power of 1 W at the antenna connector.
- SAR for nominal TSL parameters:* The measured TSL parameters are used to calculate the nominal SAR result.

The reported uncertainty of measurement is stated as the standard uncertainty of measurement multiplied by the coverage factor  $k=2$ , which for a normal distribution corresponds to a coverage probability of approximately 95%.

## Measurement Conditions

DASY system configuration, as far as not given on page 1.

|                              |                        |             |
|------------------------------|------------------------|-------------|
| DASY Version                 | DASY5                  | V52.8.8     |
| Extrapolation                | Advanced Extrapolation |             |
| Phantom                      | Modular Flat Phantom   |             |
| Distance Dipole Center - TSL | 10 mm                  | with Spacer |
| Zoom Scan Resolution         | dx, dy, dz = 5 mm      |             |
| Frequency                    | 1750 MHz ± 1 MHz       |             |

## Head TSL parameters

The following parameters and calculations were applied.

|   | Temperature     | Permittivity | Conductivity     |
|---|-----------------|--------------|------------------|
| Nominal Head TSL parameters             | 22.0 °C         | 40.1         | 1.37 mho/m       |
| Measured Head TSL parameters            | (22.0 ± 0.2) °C | 38.9 ± 6 %   | 1.35 mho/m ± 6 % |
| Head TSL temperature change during test | < 0.5 °C        | ----         | ----             |

## SAR result with Head TSL

| SAR averaged over 1 cm <sup>3</sup> (1 g) of Head TSL | Condition          |                                 |
|---|--------------------|---------------------------------|
| SAR measured  | 250 mW input power | 9.04 W/kg                       |
| SAR for nominal Head TSL parameters                   | normalized to 1W   | <b>36.2 W/kg ± 17.0 % (k=2)</b> |

| SAR averaged over 10 cm <sup>3</sup> (10 g) of Head TSL | condition          |                                 |
|---|--------------------|---------------------------------|
| SAR measured  | 250 mW input power | 4.80 W/kg                       |
| SAR for nominal Head TSL parameters                     | normalized to 1W   | <b>19.2 W/kg ± 16.5 % (k=2)</b> |

## Body TSL parameters

The following parameters and calculations were applied.

|   | Temperature     | Permittivity | Conductivity     |
|---|-----------------|--------------|------------------|
| Nominal Body TSL parameters             | 22.0 °C         | 53.4         | 1.49 mho/m       |
| Measured Body TSL parameters            | (22.0 ± 0.2) °C | 51.5 ± 6 %   | 1.48 mho/m ± 6 % |
| Body TSL temperature change during test | < 0.5 °C        | ----         | ----             |

## SAR result with Body TSL

| SAR averaged over 1 cm <sup>3</sup> (1 g) of Body TSL | Condition          |                                 |
|---|--------------------|---------------------------------|
| SAR measured  | 250 mW input power | 9.32 W/kg                       |
| SAR for nominal Body TSL parameters                   | normalized to 1W   | <b>37.1 W/kg ± 17.0 % (k=2)</b> |

| SAR averaged over 10 cm <sup>3</sup> (10 g) of Body TSL | condition          |                                 |
|---|--------------------|---------------------------------|
| SAR measured  | 250 mW input power | 5.01 W/kg                       |
| SAR for nominal Body TSL parameters                     | normalized to 1W   | <b>20.0 W/kg ± 16.5 % (k=2)</b> |

## Appendix (Additional assessments outside the scope of SCS 0108)

### Antenna Parameters with Head TSL

|                                      |                                |
|--------------------------------------|--------------------------------|
| Impedance, transformed to feed point | 51.3 $\Omega$ - 0.2 j $\Omega$ |
| Return Loss                          | - 37.5 dB                      |

### Antenna Parameters with Body TSL

|                                      |                                |
|--------------------------------------|--------------------------------|
| Impedance, transformed to feed point | 46.9 $\Omega$ + 0.3 j $\Omega$ |
| Return Loss                          | - 29.9 dB                      |

### General Antenna Parameters and Design

|                                  |          |
|----------------------------------|----------|
| Electrical Delay (one direction) | 1.221 ns |
|----------------------------------|----------|

After long term use with 100W radiated power, only a slight warming of the dipole near the feedpoint can be measured.

The dipole is made of standard semirigid coaxial cable. The center conductor of the feeding line is directly connected to the second arm of the dipole. The antenna is therefore short-circuited for DC-signals. On some of the dipoles, small end caps are added to the dipole arms in order to improve matching when loaded according to the position as explained in the "Measurement Conditions" paragraph. The SAR data are not affected by this change. The overall dipole length is still according to the Standard.

No excessive force must be applied to the dipole arms, because they might bend or the soldered connections near the feedpoint may be damaged.

### Additional EUT Data

|                 |                   |
|-----------------|-------------------|
| Manufactured by | SPEAG             |
| Manufactured on | February 19, 2010 |

# DASY5 Validation Report for Head TSL

Date: 15.04.2015

Test Laboratory: SPEAG, Zurich, Switzerland

**DUT: Dipole 1750 MHz; Type: D1750V2; Serial: D1750V2 - SN:1051**

Communication System: UID 0 - CW; Frequency: 1750 MHz

Medium parameters used:  $f = 1750$  MHz;  $\sigma = 1.35$  S/m;  $\epsilon_r = 38.9$ ;  $\rho = 1000$  kg/m<sup>3</sup>

Phantom section: Flat Section

Measurement Standard: DASY5 (IEEE/IEC/ANSI C63.19-2011)

DASY52 Configuration:

- Probe: ES3DV3 - SN3205; ConvF(5.2, 5.2, 5.2); Calibrated: 30.12.2014;
- Sensor-Surface: 3mm (Mechanical Surface Detection)
- Electronics: DAE4 Sn601; Calibrated: 18.08.2014
- Phantom: Flat Phantom 5.0 (front); Type: QD000P50AA; Serial: 1001
- DASY52 52.8.8(1222); SEMCAD X 14.6.10(7331)

## Dipole Calibration for Head Tissue/Pin=250 mW, d=10mm/Zoom Scan (7x7x7)/Cube 0:

Measurement grid: dx=5mm, dy=5mm, dz=5mm

Reference Value = 94.99 V/m; Power Drift = 0.06 dB

Peak SAR (extrapolated) = 16.3 W/kg

**SAR(1 g) = 9.04 W/kg; SAR(10 g) = 4.8 W/kg**

Maximum value of SAR (measured) = 11.5 W/kg

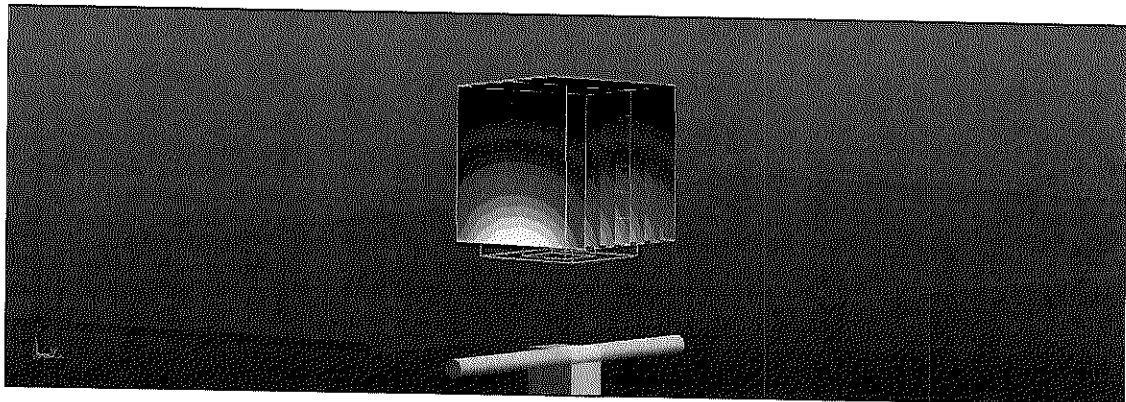
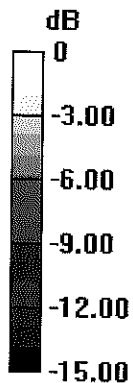

0 dB = 11.5 W/kg = 10.61 dBW/kg

# Impedance Measurement Plot for Head TSL

[CH1] S11 1 U FS 3: 51.330  $\Omega$  -248.05 m $\Omega$  366.65 pF 15 Apr 2015 12:25:31  
 1 750.000 000 MHz

\*  
 Del  
 C $\Delta$   
 Avg  
 16  
 H1d

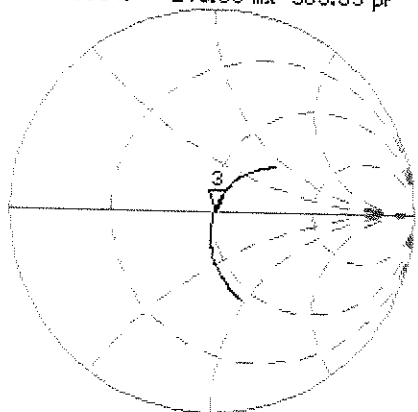

CH2 S11 LOG 5 dB/REF -20 dB 3: -37.470 dB 1 750.000 000 MHz

C $\Delta$   
 Avg  
 16  
 H1d

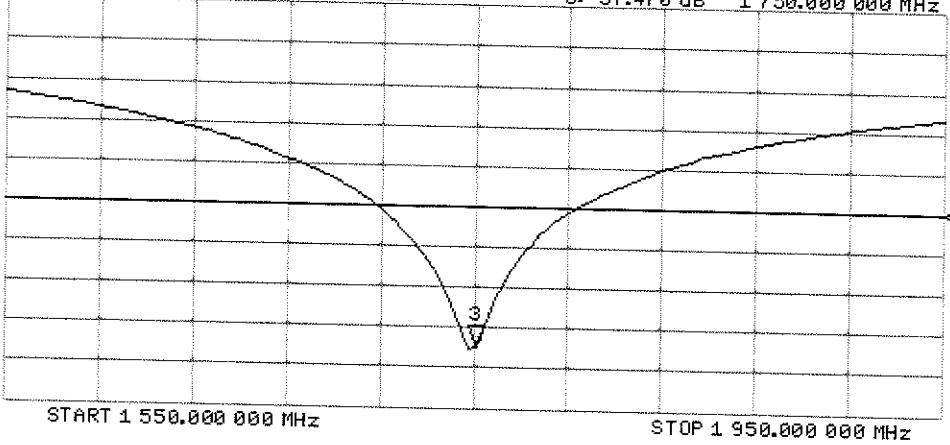

# DASY5 Validation Report for Body TSL

Date: 15.04.2015

Test Laboratory: SPEAG, Zurich, Switzerland

**DUT: Dipole 1750 MHz; Type: D1750V2; Serial: D1750V2 - SN:1051**

Communication System: UID 0 - CW; Frequency: 1750 MHz

Medium parameters used:  $f = 1750$  MHz;  $\sigma = 1.48$  S/m;  $\epsilon_r = 51.5$ ;  $\rho = 1000$  kg/m<sup>3</sup>

Phantom section: Flat Section

Measurement Standard: DASY5 (IEEE/IEC/ANSI C63.19-2011)

DASY52 Configuration:

- Probe: ES3DV3 - SN3205; ConvF(4.88, 4.88, 4.88); Calibrated: 30.12.2014;
- Sensor-Surface: 3mm (Mechanical Surface Detection)
- Electronics: DAE4 Sn601; Calibrated: 18.08.2014
- Phantom: Flat Phantom 5.0 (back); Type: QD000P50AA; Serial: 1002
- DASY52 52.8.8(1222); SEMCAD X 14.6.10(7331)

## Dipole Calibration for Body Tissue/Pin=250 mW, d=10mm/Zoom Scan (7x7x7)/Cube 0:

Measurement grid: dx=5mm, dy=5mm, dz=5mm

Reference Value = 92.87 V/m; Power Drift = 0.01 dB

Peak SAR (extrapolated) = 16.0 W/kg

**SAR(1 g) = 9.32 W/kg; SAR(10 g) = 5.01 W/kg**

Maximum value of SAR (measured) = 11.7 W/kg

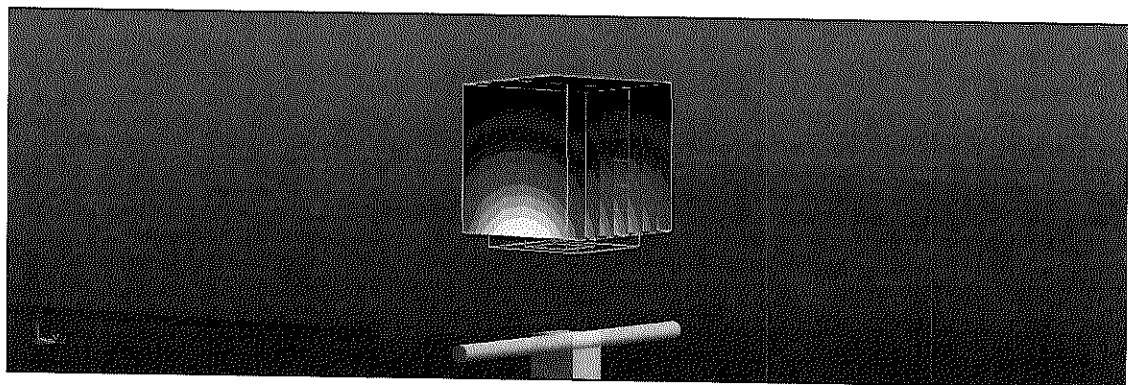
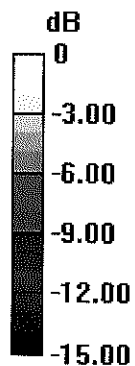

0 dB = 11.7 W/kg = 10.68 dBW/kg

# Impedance Measurement Plot for Body TSL

15 Apr 2015 12:23:57  
[CH1] S11 1 U FS 3: 46.930  $\Omega$  0.3242  $\Omega$  29.486 pF 1 750.000 000 MHz

#  
De1  
Ca  
Avg  
16  
H1d

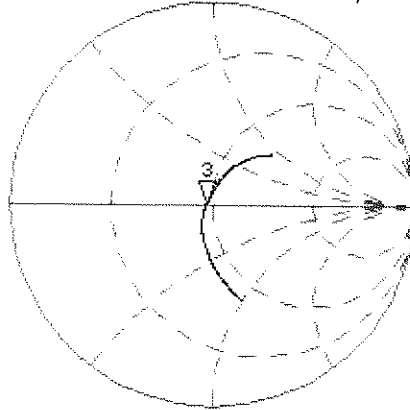

CH2 S11 LOG 5 dB/REF -20 dB 3:-29.939 dB 1 750.000 000 MHz

Ca  
Avg  
16  
H1d

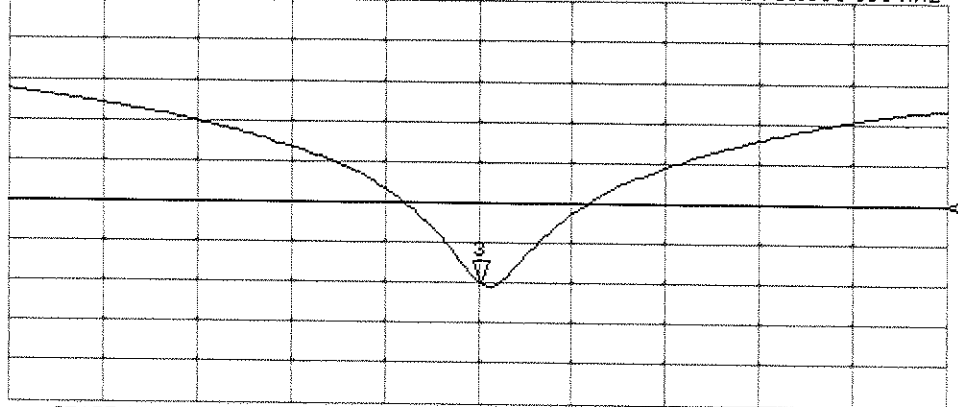

**Calibration Laboratory of  
Schmid & Partner  
Engineering AG**  
Zeughausstrasse 43, 8004 Zurich, Switzerland



**S** Schweizerischer Kalibrierdienst  
**C** Service suisse d'étalonnage  
**S** Servizio svizzero di taratura  
Swiss Calibration Service

Accredited by the Swiss Accreditation Service (SAS)  
The Swiss Accreditation Service is one of the signatories to the EA  
Multilateral Agreement for the recognition of calibration certificates

Accreditation No.: **SCS 0108**

Client **PC Test**

Certificate No: **ES3-3213\_Jan15**

**CALIBRATION CERTIFICATE**

Object **ES3DV3 - SN:3213**

Calibration procedure(s) **QA CAL-01.v9, QA CAL-23.v5, QA CAL-25.v6  
Calibration procedure for dosimetric E-field probes**

CC  
1/30/15

Calibration date: **January 20, 2015**

This calibration certificate documents the traceability to national standards, which realize the physical units of measurements (SI).  
The measurements and the uncertainties with confidence probability are given on the following pages and are part of the certificate.

All calibrations have been conducted in the closed laboratory facility: environment temperature (22 ± 3)°C and humidity < 70%.

Calibration Equipment used (M&TE critical for calibration)

| Primary Standards          | ID              | Cal Date (Certificate No.)        | Scheduled Calibration  |
|----------------------------|-----------------|-----------------------------------|------------------------|
| Power meter E4419B         | GB41293874      | 03-Apr-14 (No. 217-01911)         | Apr-15                 |
| Power sensor E4412A        | MY41498087      | 03-Apr-14 (No. 217-01911)         | Apr-15                 |
| Reference 3 dB Attenuator  | SN: S5054 (3c)  | 03-Apr-14 (No. 217-01915)         | Apr-15                 |
| Reference 20 dB Attenuator | SN: S5277 (20x) | 03-Apr-14 (No. 217-01919)         | Apr-15                 |
| Reference 30 dB Attenuator | SN: S5129 (30b) | 03-Apr-14 (No. 217-01920)         | Apr-15                 |
| Reference Probe ES3DV2     | SN: 3013        | 30-Dec-14 (No. ES3-3013_Dec14)    | Dec-15                 |
| DAE4                       | SN: 660         | 14-Jan-15 (No. DAE4-660_Jan15)    | Jan-16                 |
| Secondary Standards        | ID              | Check Date (in house)             | Scheduled Check        |
| RF generator HP 8648C      | US3642U01700    | 4-Aug-99 (in house check Apr-13)  | In house check: Apr-16 |
| Network Analyzer HP 8753E  | US37390585      | 18-Oct-01 (in house check Oct-14) | In house check: Oct-15 |

|                |                              |  |               |
|----------------|------------------------------|--|---------------|
| Calibrated by: | Name<br><b>Israe Elnaouq</b> | Function<br><b>Laboratory Technician</b> | Signature<br> |
| Approved by:   | <b>Katja Pokovic</b>         | <b>Technical Manager</b>                 |               |

Issued: January 22, 2015

This calibration certificate shall not be reproduced except in full without written approval of the laboratory.



Accredited by the Swiss Accreditation Service (SAS)

Accreditation No.: **SCS 0108**

The Swiss Accreditation Service is one of the signatories to the EA  
Multilateral Agreement for the recognition of calibration certificates

**Glossary:**

|                       |   |
|-----------------------|---|
| TSL                   | tissue simulating liquid  |
| NORM <sub>x,y,z</sub> | sensitivity in free space   |
| ConvF                 | sensitivity in TSL / NORM <sub>x,y,z</sub>  |
| DCP                   | diode compression point   |
| CF                    | crest factor (1/duty_cycle) of the RF signal  |
| A, B, C, D            | modulation dependent linearization parameters   |
| Polarization φ        | φ rotation around probe axis  |
| Polarization θ        | θ rotation around an axis that is in the plane normal to probe axis (at measurement center),<br>i.e., θ = 0 is normal to probe axis |
| Connector Angle       | information used in DASY system to align probe sensor X to the robot coordinate system  |

**Calibration is Performed According to the Following Standards:**

- a) IEEE Std 1528-2013, "IEEE Recommended Practice for Determining the Peak Spatial-Averaged Specific Absorption Rate (SAR) in the Human Head from Wireless Communications Devices: Measurement Techniques", June 2013
- b) IEC 62209-1, "Procedure to measure the Specific Absorption Rate (SAR) for hand-held devices used in close proximity to the ear (frequency range of 300 MHz to 3 GHz)", February 2005

**Methods Applied and Interpretation of Parameters:**

- *NORM<sub>x,y,z</sub>*: Assessed for E-field polarization θ = 0 (f ≤ 900 MHz in TEM-cell; f > 1800 MHz: R22 waveguide). *NORM<sub>x,y,z</sub>* are only intermediate values, i.e., the uncertainties of *NORM<sub>x,y,z</sub>* does not affect the E<sup>2</sup>-field uncertainty inside TSL (see below *ConvF*).
- *NORM(f)<sub>x,y,z</sub> = NORM<sub>x,y,z</sub> \* frequency\_response* (see Frequency Response Chart). This linearization is implemented in DASY4 software versions later than 4.2. The uncertainty of the frequency response is included in the stated uncertainty of *ConvF*.
- *DCP<sub>x,y,z</sub>*: DCP are numerical linearization parameters assessed based on the data of power sweep with CW signal (no uncertainty required). DCP does not depend on frequency nor media.
- *PAR*: PAR is the Peak to Average Ratio that is not calibrated but determined based on the signal characteristics
- *A<sub>x,y,z</sub>; B<sub>x,y,z</sub>; C<sub>x,y,z</sub>; D<sub>x,y,z</sub>; VR<sub>x,y,z</sub>*: A, B, C, D are numerical linearization parameters assessed based on the data of power sweep for specific modulation signal. The parameters do not depend on frequency nor media. VR is the maximum calibration range expressed in RMS voltage across the diode.
- *ConvF and Boundary Effect Parameters*: Assessed in flat phantom using E-field (or Temperature Transfer Standard for f ≤ 800 MHz) and inside waveguide using analytical field distributions based on power measurements for f > 800 MHz. The same setups are used for assessment of the parameters applied for boundary compensation (alpha, depth) of which typical uncertainty values are given. These parameters are used in DASY4 software to improve probe accuracy close to the boundary. The sensitivity in TSL corresponds to *NORM<sub>x,y,z</sub> \* ConvF* whereby the uncertainty corresponds to that given for *ConvF*. A frequency dependent *ConvF* is used in DASY version 4.4 and higher which allows extending the validity from ± 50 MHz to ± 100 MHz.
- *Spherical isotropy (3D deviation from isotropy)*: in a field of low gradients realized using a flat phantom exposed by a patch antenna.
- *Sensor Offset*: The sensor offset corresponds to the offset of virtual measurement center from the probe tip (on probe axis). No tolerance required.
- *Connector Angle*: The angle is assessed using the information gained by determining the *NORM<sub>x</sub>* (no uncertainty required).

# Probe ES3DV3

## SN:3213

Manufactured: October 14, 2008  
Calibrated: January 20, 2015

Calibrated for DASY/EASY Systems  
(Note: non-compatible with DASY2 system!)

# DASY/EASY - Parameters of Probe: ES3DV3 - SN:3213

## Basic Calibration Parameters

|                                       | Sensor X | Sensor Y | Sensor Z | Unc (k=2)     |
|---------------------------------------|----------|----------|----------|---------------|
| Norm ( $\mu V/(V/m)^2$ ) <sup>A</sup> | 1.49     | 1.37     | 1.34     | $\pm 10.1 \%$ |
| DCP (mV) <sup>B</sup>                 | 99.9     | 101.8    | 101.4    |               |

## Modulation Calibration Parameters

| UID       | Communication System Name                     |   | A<br>dB | B<br>dB $\sqrt{\mu V}$ | C    | D<br>dB | VR<br>mV | Unc <sup>E</sup><br>(k=2) |
|-----------|---|---|---------|------------------------|------|---------|----------|---------------------------|
| 0         | CW  | X | 0.0     | 0.0                    | 1.0  | 0.00    | 169.8    | $\pm 3.8 \%$              |
|           |   | Y | 0.0     | 0.0                    | 1.0  |         | 215.4    |                           |
|           |   | Z | 0.0     | 0.0                    | 1.0  |         | 214.5    |                           |
| 10010-CAA | SAR Validation (Square, 100ms, 10ms)          | X | 1.84    | 57.8                   | 10.2 | 10.00   | 47.4     | $\pm 1.9 \%$              |
|           |   | Y | 1.82    | 58.6                   | 10.3 |         | 44.3     |                           |
|           |   | Z | 1.65    | 57.3                   | 9.2  |         | 44.2     |                           |
| 10011-CAB | UMTS-FDD (WCDMA)                              | X | 3.32    | 66.8                   | 18.5 | 2.91    | 135.8    | $\pm 0.5 \%$              |
|           |   | Y | 3.18    | 66.4                   | 18.2 |         | 127.9    |                           |
|           |   | Z | 3.21    | 66.5                   | 18.2 |         | 128.1    |                           |
| 10012-CAB | IEEE 802.11b WiFi 2.4 GHz (DSSS, 1 Mbps)      | X | 2.90    | 68.1                   | 18.4 | 1.87    | 137.2    | $\pm 0.7 \%$              |
|           |   | Y | 2.97    | 69.2                   | 19.0 |         | 130.1    |                           |
|           |   | Z | 2.80    | 68.0                   | 18.4 |         | 129.9    |                           |
| 10013-CAB | IEEE 802.11g WiFi 2.4 GHz (DSSS-OFDM, 6 Mbps) | X | 11.40   | 71.2                   | 23.7 | 9.46    | 135.1    | $\pm 3.8 \%$              |
|           |   | Y | 11.25   | 71.3                   | 23.9 |         | 124.2    |                           |
|           |   | Z | 10.96   | 70.3                   | 23.2 |         | 124.8    |                           |
| 10021-DAB | GSM-FDD (TDMA, GMSK)                          | X | 18.25   | 96.6                   | 27.2 | 9.39    | 140.4    | $\pm 1.7 \%$              |
|           |   | Y | 21.48   | 99.9                   | 28.2 |         | 133.3    |                           |
|           |   | Z | 11.76   | 89.4                   | 24.5 |         | 127.3    |                           |
| 10023-DAB | GPRS-FDD (TDMA, GMSK, TN 0)                   | X | 13.12   | 91.7                   | 26.0 | 9.57    | 126.4    | $\pm 1.9 \%$              |
|           |   | Y | 17.05   | 95.2                   | 26.6 |         | 127.3    |                           |
|           |   | Z | 8.91    | 85.2                   | 23.3 |         | 118.8    |                           |
| 10024-DAB | GPRS-FDD (TDMA, GMSK, TN 0-1)                 | X | 34.78   | 100.0                  | 25.2 | 6.56    | 116.4    | $\pm 1.7 \%$              |
|           |   | Y | 33.37   | 99.5                   | 24.8 |         | 111.7    |                           |
|           |   | Z | 34.11   | 99.5                   | 24.6 |         | 110.5    |                           |
| 10027-DAB | GPRS-FDD (TDMA, GMSK, TN 0-1-2)               | X | 37.18   | 99.7                   | 24.0 | 4.80    | 131.2    | $\pm 1.7 \%$              |
|           |   | Y | 44.91   | 99.8                   | 23.3 |         | 127.4    |                           |
|           |   | Z | 41.51   | 99.7                   | 23.2 |         | 125.0    |                           |
| 10028-DAB | GPRS-FDD (TDMA, GMSK, TN 0-1-2-3)             | X | 48.95   | 99.5                   | 22.4 | 3.55    | 140.9    | $\pm 1.7 \%$              |
|           |   | Y | 67.41   | 99.8                   | 21.5 |         | 137.8    |                           |
|           |   | Z | 56.45   | 100.0                  | 21.9 |         | 135.0    |                           |
| 10032-CAA | IEEE 802.15.1 Bluetooth (GFSK, DH5)           | X | 20.23   | 99.3                   | 22.1 | 1.16    | 111.3    | $\pm 1.2 \%$              |
|           |   | Y | 32.72   | 99.5                   | 20.6 |         | 109.6    |                           |
|           |   | Z | 48.57   | 100.0                  | 20.0 |         | 108.8    |                           |
| 10100-CAB | LTE-FDD (SC-FDMA, 100% RB, 20 MHz, QPSK)      | X | 6.60    | 67.9                   | 20.0 | 5.67    | 144.6    | $\pm 1.2 \%$              |
|           |   | Y | 6.55    | 68.2                   | 20.2 |         | 142.7    |                           |
|           |   | Z | 6.50    | 67.8                   | 19.9 |         | 141.5    |                           |

|           |  |   |       |      |      |      |       |        |
|-----------|--|---|-------|------|------|------|-------|--------|
| 10103-CAB | LTE-TDD (SC-FDMA, 100% RB, 20 MHz, QPSK) | X | 10.34 | 75.7 | 26.2 | 9.29 | 133.2 | ±2.5 % |
|           |  | Y | 10.31 | 76.5 | 26.9 |      | 128.2 |        |
|           |  | Z | 9.74  | 74.5 | 25.6 |      | 127.1 |        |
| 10108-CAC | LTE-FDD (SC-FDMA, 100% RB, 10 MHz, QPSK) | X | 6.50  | 67.6 | 20.0 | 5.80 | 142.8 | ±1.2 % |
|           |  | Y | 6.41  | 67.7 | 20.1 |      | 140.3 |        |
|           |  | Z | 6.41  | 67.6 | 19.9 |      | 140.2 |        |
| 10117-CAB | IEEE 802.11n (HT Mixed, 13.5 Mbps, BPSK) | X | 10.36 | 69.2 | 21.6 | 8.07 | 132.8 | ±2.7 % |
|           |  | Y | 10.42 | 69.7 | 21.9 |      | 131.4 |        |
|           |  | Z | 10.22 | 69.1 | 21.4 |      | 130.0 |        |
| 10151-CAB | LTE-TDD (SC-FDMA, 50% RB, 20 MHz, QPSK)  | X | 9.65  | 74.6 | 25.8 | 9.28 | 127.9 | ±2.5 % |
|           |  | Y | 9.66  | 75.6 | 26.7 |      | 123.7 |        |
|           |  | Z | 9.14  | 73.6 | 25.3 |      | 122.7 |        |
| 10154-CAC | LTE-FDD (SC-FDMA, 50% RB, 10 MHz, QPSK)  | X | 6.14  | 66.9 | 19.6 | 5.75 | 139.3 | ±1.4 % |
|           |  | Y | 6.08  | 67.2 | 19.9 |      | 138.5 |        |
|           |  | Z | 6.05  | 66.9 | 19.6 |      | 137.3 |        |
| 10160-CAB | LTE-FDD (SC-FDMA, 50% RB, 15 MHz, QPSK)  | X | 6.58  | 67.5 | 19.9 | 5.82 | 144.3 | ±1.4 % |
|           |  | Y | 6.54  | 67.8 | 20.1 |      | 143.7 |        |
|           |  | Z | 6.50  | 67.5 | 19.8 |      | 142.1 |        |
| 10169-CAB | LTE-FDD (SC-FDMA, 1 RB, 20 MHz, QPSK)    | X | 4.93  | 66.1 | 19.3 | 5.73 | 120.6 | ±0.9 % |
|           |  | Y | 4.93  | 66.7 | 19.8 |      | 120.9 |        |
|           |  | Z | 4.85  | 66.3 | 19.5 |      | 118.9 |        |
| 10172-CAB | LTE-TDD (SC-FDMA, 1 RB, 20 MHz, QPSK)    | X | 8.93  | 79.5 | 28.6 | 9.21 | 140.8 | ±2.5 % |
|           |  | Y | 9.60  | 82.9 | 30.6 |      | 139.9 |        |
|           |  | Z | 8.30  | 78.2 | 27.9 |      | 136.6 |        |
| 10175-CAC | LTE-FDD (SC-FDMA, 1 RB, 10 MHz, QPSK)    | X | 4.90  | 66.0 | 19.3 | 5.72 | 118.8 | ±0.9 % |
|           |  | Y | 4.93  | 66.8 | 19.8 |      | 120.2 |        |
|           |  | Z | 4.81  | 66.1 | 19.3 |      | 116.6 |        |
| 10181-CAB | LTE-FDD (SC-FDMA, 1 RB, 15 MHz, QPSK)    | X | 4.92  | 66.1 | 19.3 | 5.72 | 119.0 | ±0.9 % |
|           |  | Y | 4.92  | 66.6 | 19.8 |      | 120.5 |        |
|           |  | Z | 4.77  | 65.8 | 19.2 |      | 115.8 |        |
| 10196-CAB | IEEE 802.11n (HT Mixed, 6.5 Mbps, BPSK)  | X | 9.93  | 68.7 | 21.4 | 8.10 | 125.0 | ±2.5 % |
|           |  | Y | 10.06 | 69.4 | 21.9 |      | 128.3 |        |
|           |  | Z | 9.78  | 68.5 | 21.2 |      | 120.5 |        |
| 10225-CAB | UMTS-FDD (HSPA+)                         | X | 6.66  | 65.7 | 18.8 | 5.97 | 106.5 | ±0.9 % |
|           |  | Y | 6.81  | 66.6 | 19.3 |      | 112.3 |        |
|           |  | Z | 6.64  | 66.0 | 18.9 |      | 108.0 |        |
| 10237-CAB | LTE-TDD (SC-FDMA, 1 RB, 10 MHz, QPSK)    | X | 8.91  | 79.4 | 28.5 | 9.21 | 141.4 | ±2.2 % |
|           |  | Y | 9.39  | 82.3 | 30.4 |      | 146.7 |        |
|           |  | Z | 8.40  | 78.5 | 28.2 |      | 141.2 |        |
| 10252-CAB | LTE-TDD (SC-FDMA, 50% RB, 10 MHz, QPSK)  | X | 8.84  | 73.3 | 25.2 | 9.24 | 119.1 | ±2.7 % |
|           |  | Y | 8.94  | 74.6 | 26.3 |      | 118.6 |        |
|           |  | Z | 8.39  | 72.4 | 24.7 |      | 114.0 |        |
| 10267-CAB | LTE-TDD (SC-FDMA, 100% RB, 10 MHz, QPSK) | X | 9.62  | 74.6 | 25.8 | 9.30 | 126.2 | ±2.7 % |
|           |  | Y | 9.77  | 76.0 | 26.9 |      | 126.1 |        |
|           |  | Z | 9.10  | 73.4 | 25.2 |      | 121.4 |        |

|           |   |   |       |      |      |      |       |        |
|-----------|---|---|-------|------|------|------|-------|--------|
| 10275-CAB | UMTS-FDD (HSUPA, Subtest 5, 3GPP Rel8.4)                      | X | 4.43  | 66.4 | 18.5 | 3.96 | 132.5 | ±0.7 % |
|           |   | Y | 4.37  | 66.6 | 18.6 |      | 134.1 |        |
|           |   | Z | 4.40  | 66.7 | 18.6 |      | 130.5 |        |
| 10291-AAB | CDMA2000, RC3, SO55, Full Rate                                | X | 3.63  | 66.4 | 18.4 | 3.46 | 122.5 | ±0.5 % |
|           |   | Y | 3.54  | 66.5 | 18.5 |      | 124.9 |        |
|           |   | Z | 3.55  | 66.3 | 18.3 |      | 121.4 |        |
| 10292-AAB | CDMA2000, RC3, SO32, Full Rate                                | X | 3.49  | 65.9 | 18.1 | 3.39 | 125.1 | ±0.5 % |
|           |   | Y | 3.52  | 66.7 | 18.6 |      | 126.1 |        |
|           |   | Z | 3.51  | 66.5 | 18.4 |      | 123.8 |        |
| 10297-AAA | LTE-FDD (SC-FDMA, 50% RB, 20 MHz, QPSK)                       | X | 6.49  | 67.6 | 19.9 | 5.81 | 143.1 | ±1.4 % |
|           |   | Y | 6.49  | 68.0 | 20.3 |      | 142.3 |        |
|           |   | Z | 6.42  | 67.6 | 19.9 |      | 144.3 |        |
| 10311-AAA | LTE-FDD (SC-FDMA, 100% RB, 15 MHz, QPSK)                      | X | 7.06  | 68.1 | 20.2 | 6.06 | 147.6 | ±1.7 % |
|           |   | Y | 7.09  | 68.7 | 20.7 |      | 148.2 |        |
|           |   | Z | 7.03  | 68.3 | 20.4 |      | 149.8 |        |
| 10403-AAB | CDMA2000 (1xEV-DO, Rev. 0)                                    | X | 4.66  | 67.4 | 18.4 | 3.76 | 135.3 | ±0.5 % |
|           |   | Y | 4.69  | 68.1 | 18.7 |      | 134.9 |        |
|           |   | Z | 4.72  | 68.2 | 18.7 |      | 136.5 |        |
| 10404-AAB | CDMA2000 (1xEV-DO, Rev. A)                                    | X | 4.58  | 67.4 | 18.3 | 3.77 | 133.4 | ±0.5 % |
|           |   | Y | 4.68  | 68.4 | 18.9 |      | 132.8 |        |
|           |   | Z | 4.58  | 67.9 | 18.5 |      | 135.4 |        |
| 10415-AAA | IEEE 802.11b WiFi 2.4 GHz (DSSS, 1 Mbps, 99pc duty cycle)     | X | 2.41  | 65.7 | 17.2 | 1.54 | 131.4 | ±0.7 % |
|           |   | Y | 2.42  | 66.4 | 17.7 |      | 131.3 |        |
|           |   | Z | 2.59  | 67.7 | 18.2 |      | 134.1 |        |
| 10416-AAA | IEEE 802.11g WiFi 2.4 GHz (ERP-OFDM, 6 Mbps, 99pc duty cycle) | X | 10.06 | 68.9 | 21.5 | 8.23 | 127.6 | ±2.7 % |
|           |   | Y | 10.12 | 69.5 | 22.0 |      | 126.3 |        |
|           |   | Z | 10.04 | 69.1 | 21.7 |      | 129.7 |        |

The reported uncertainty of measurement is stated as the standard uncertainty of measurement multiplied by the coverage factor  $k=2$ , which for a normal distribution corresponds to a coverage probability of approximately 95%.

<sup>A</sup> The uncertainties of NormX,Y,Z do not affect the  $E^2$ -field uncertainty inside TSL (see Pages 7 and 8).

<sup>B</sup> Numerical linearization parameter: uncertainty not required.

<sup>E</sup> Uncertainty is determined using the max. deviation from linear response applying rectangular distribution and is expressed for the square of the field value.

## DASY/EASY - Parameters of Probe: ES3DV3 - SN:3213

### Calibration Parameter Determined in Head Tissue Simulating Media

| f (MHz) <sup>c</sup> | Relative Permittivity <sup>F</sup> | Conductivity (S/m) <sup>F</sup> | ConvF X | ConvF Y | ConvF Z | Alpha <sup>G</sup> | Depth <sup>G</sup> (mm) | Unct. (k=2) |
|----------------------|------------------------------------|---------------------------------|---------|---------|---------|--------------------|-------------------------|-------------|
| 750                  | 41.9                               | 0.89                            | 6.45    | 6.45    | 6.45    | 0.57               | 1.37                    | ± 12.0 %    |
| 835                  | 41.5                               | 0.90                            | 6.26    | 6.26    | 6.26    | 0.65               | 1.26                    | ± 12.0 %    |
| 1750                 | 40.1                               | 1.37                            | 5.22    | 5.22    | 5.22    | 0.47               | 1.47                    | ± 12.0 %    |
| 1900                 | 40.0                               | 1.40                            | 5.06    | 5.06    | 5.06    | 0.80               | 1.14                    | ± 12.0 %    |
| 2450                 | 39.2                               | 1.80                            | 4.54    | 4.54    | 4.54    | 0.78               | 1.22                    | ± 12.0 %    |
| 2600                 | 39.0                               | 1.96                            | 4.33    | 4.33    | 4.33    | 0.80               | 1.28                    | ± 12.0 %    |

<sup>c</sup> Frequency validity above 300 MHz of ± 100 MHz only applies for DASY v4.4 and higher (see Page 2), else it is restricted to ± 50 MHz. The uncertainty is the RSS of the ConvF uncertainty at calibration frequency and the uncertainty for the indicated frequency band. Frequency validity below 300 MHz is ± 10, 25, 40, 50 and 70 MHz for ConvF assessments at 30, 64, 128, 150 and 220 MHz respectively. Above 5 GHz frequency validity can be extended to ± 110 MHz.

<sup>F</sup> At frequencies below 3 GHz, the validity of tissue parameters ( $\epsilon$  and  $\sigma$ ) can be relaxed to ± 10% if liquid compensation formula is applied to measured SAR values. At frequencies above 3 GHz, the validity of tissue parameters ( $\epsilon$  and  $\sigma$ ) is restricted to ± 5%. The uncertainty is the RSS of the ConvF uncertainty for indicated target tissue parameters.

<sup>G</sup> Alpha/Depth are determined during calibration. SPEAG warrants that the remaining deviation due to the boundary effect after compensation is always less than ± 1% for frequencies below 3 GHz and below ± 2% for frequencies between 3-6 GHz at any distance larger than half the probe tip diameter from the boundary.

## DASY/EASY - Parameters of Probe: ES3DV3 - SN:3213

### Calibration Parameter Determined in Body Tissue Simulating Media

| f (MHz) <sup>C</sup> | Relative Permittivity <sup>F</sup> | Conductivity (S/m) <sup>F</sup> | ConvF X | ConvF Y | ConvF Z | Alpha <sup>G</sup> | Depth <sup>G</sup> (mm) | Unct. (k=2) |
|----------------------|------------------------------------|---------------------------------|---------|---------|---------|--------------------|-------------------------|-------------|
| 750                  | 55.5                               | 0.96                            | 6.11    | 6.11    | 6.11    | 0.71               | 1.24                    | ± 12.0 %    |
| 835                  | 55.2                               | 0.97                            | 6.07    | 6.07    | 6.07    | 0.35               | 1.86                    | ± 12.0 %    |
| 1750                 | 53.4                               | 1.49                            | 4.93    | 4.93    | 4.93    | 0.51               | 1.47                    | ± 12.0 %    |
| 1900                 | 53.3                               | 1.52                            | 4.72    | 4.72    | 4.72    | 0.80               | 1.20                    | ± 12.0 %    |
| 2450                 | 52.7                               | 1.95                            | 4.37    | 4.37    | 4.37    | 0.71               | 1.12                    | ± 12.0 %    |
| 2600                 | 52.5                               | 2.16                            | 4.20    | 4.20    | 4.20    | 0.66               | 0.95                    | ± 12.0 %    |

<sup>C</sup> Frequency validity above 300 MHz of ± 100 MHz only applies for DASY v4.4 and higher (see Page 2), else it is restricted to ± 50 MHz. The uncertainty is the RSS of the ConvF uncertainty at calibration frequency and the uncertainty for the indicated frequency band. Frequency validity below 300 MHz is ± 10, 25, 40, 50 and 70 MHz for ConvF assessments at 30, 64, 128, 150 and 220 MHz respectively. Above 5 GHz frequency validity can be extended to ± 110 MHz.

<sup>F</sup> At frequencies below 3 GHz, the validity of tissue parameters ( $\epsilon$  and  $\sigma$ ) can be relaxed to ± 10% if liquid compensation formula is applied to measured SAR values. At frequencies above 3 GHz, the validity of tissue parameters ( $\epsilon$  and  $\sigma$ ) is restricted to ± 5%. The uncertainty is the RSS of the ConvF uncertainty for indicated target tissue parameters.

<sup>G</sup> Alpha/Depth are determined during calibration. SPEAG warrants that the remaining deviation due to the boundary effect after compensation is always less than ± 1% for frequencies below 3 GHz and below ± 2% for frequencies between 3-6 GHz at any distance larger than half the probe tip diameter from the boundary.

### Frequency Response of E-Field (TEM-Cell:ifi110 EXX, Waveguide: R22)

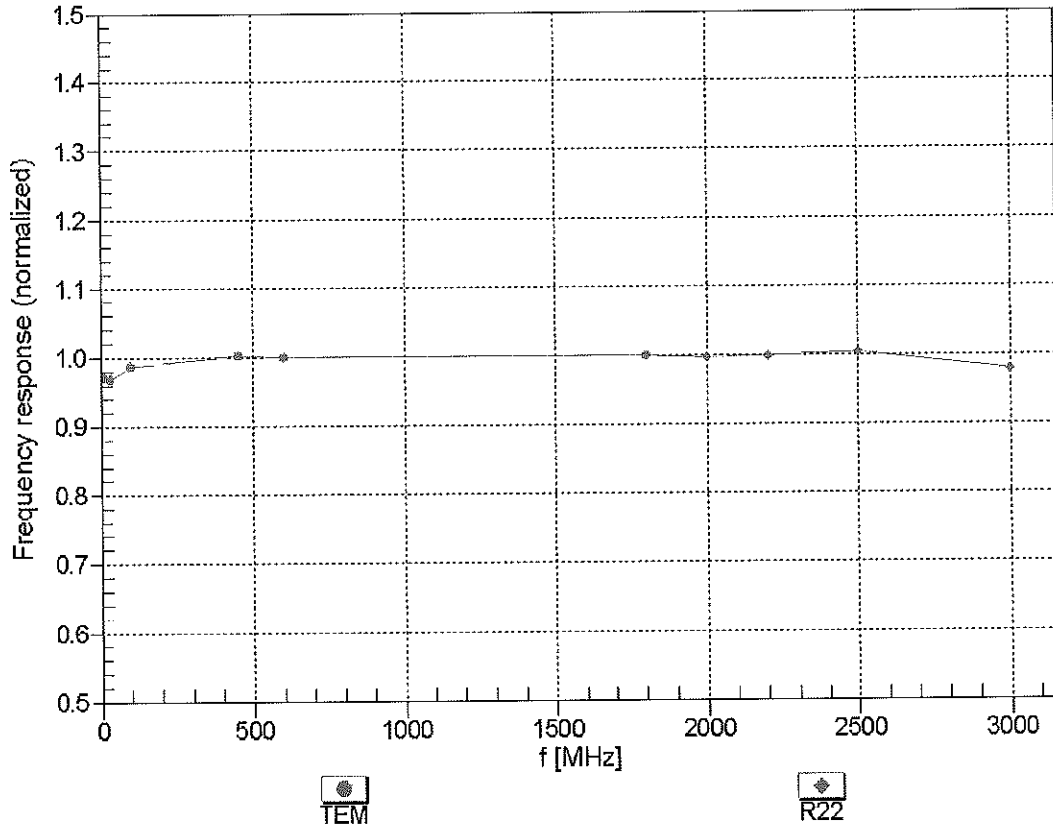

Uncertainty of Frequency Response of E-field:  $\pm 6.3\%$  (k=2)

### Receiving Pattern ( $\phi$ ), $\theta = 0^\circ$

f=600 MHz, TEM

f=1800 MHz, R22

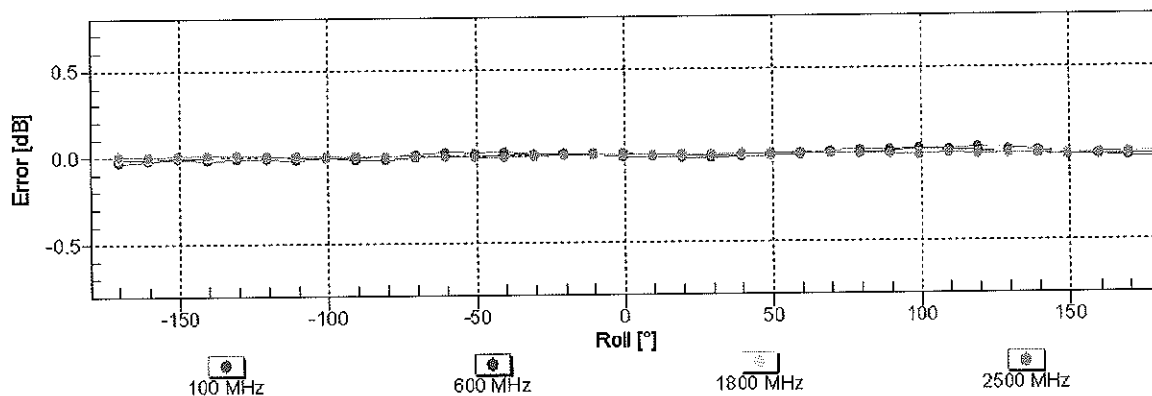
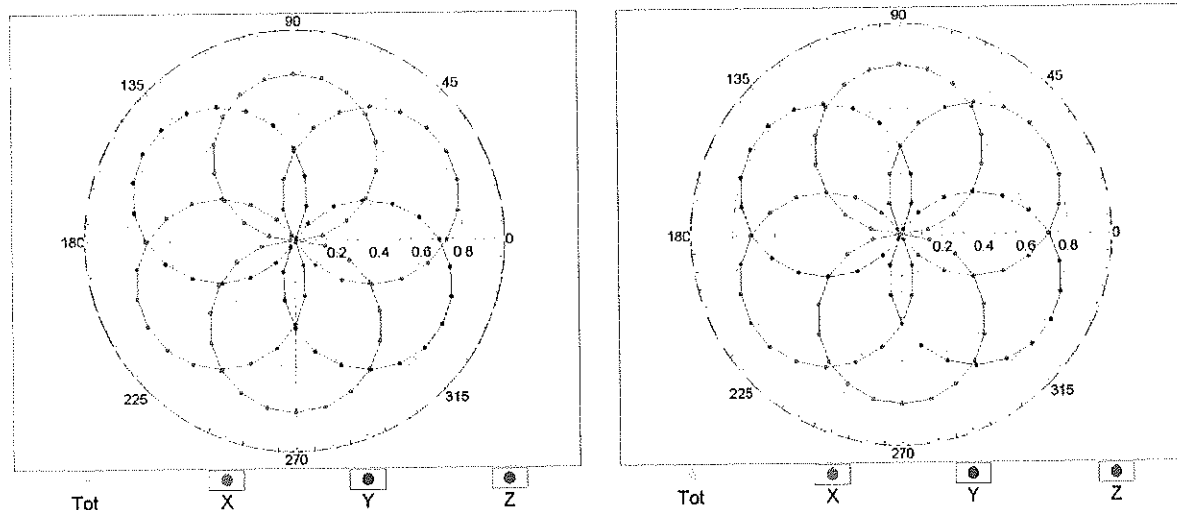

Uncertainty of Axial Isotropy Assessment:  $\pm 0.5\%$  (k=2)

### Dynamic Range f(SAR<sub>head</sub>) (TEM cell , f<sub>eval</sub>= 1900 MHz)

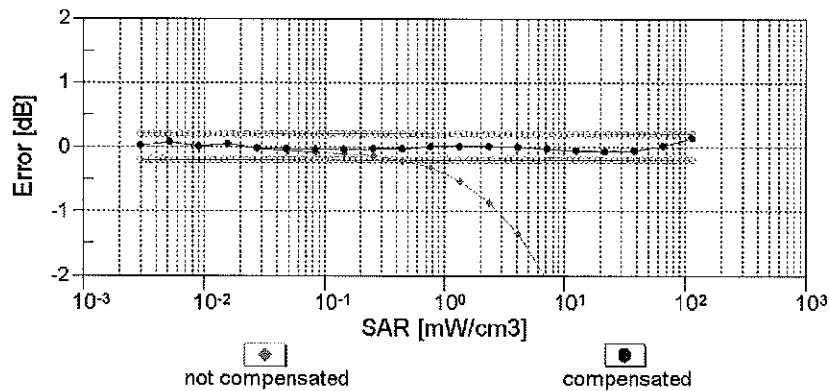
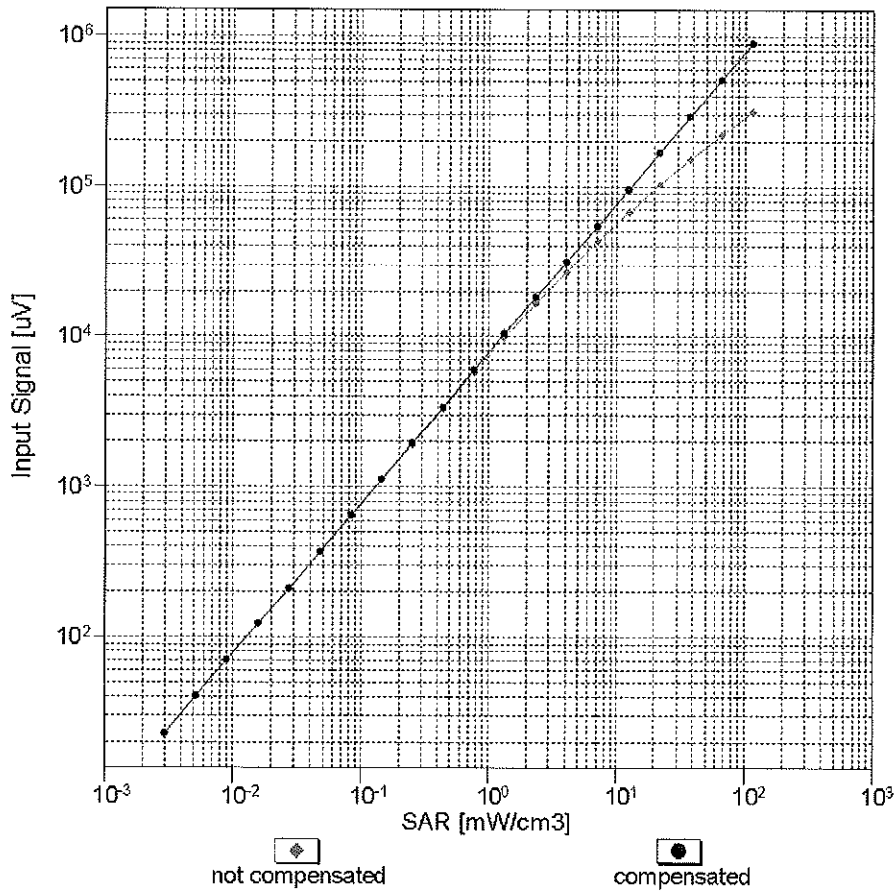

**Uncertainty of Linearity Assessment: ± 0.6% (k=2)**

# Conversion Factor Assessment

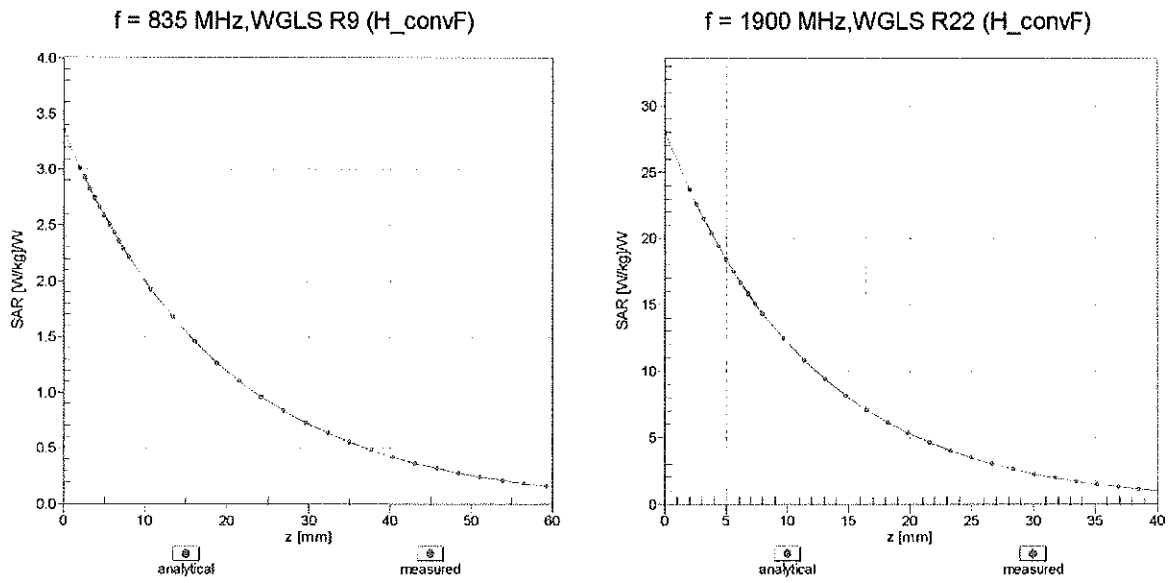

## Deviation from Isotropy in Liquid Error ( $\phi, \theta$ ), f = 900 MHz

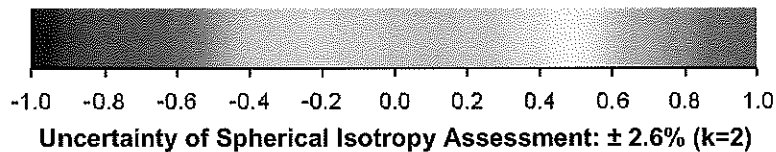
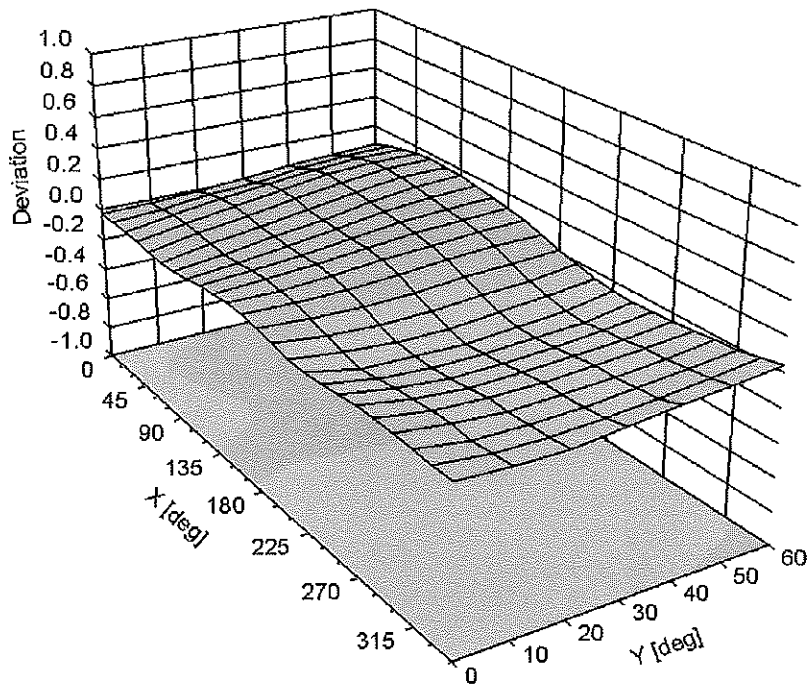

## DASY/EASY - Parameters of Probe: ES3DV3 - SN:3213

### Other Probe Parameters

|   |            |
|---|------------|
| Sensor Arrangement                            | Triangular |
| Connector Angle (°)                           | -70.6      |
| Mechanical Surface Detection Mode             | enabled    |
| Optical Surface Detection Mode                | disabled   |
| Probe Overall Length                          | 337 mm     |
| Probe Body Diameter                           | 10 mm      |
| Tip Length                                    | 10 mm      |
| Tip Diameter                                  | 4 mm       |
| Probe Tip to Sensor X Calibration Point       | 2 mm       |
| Probe Tip to Sensor Y Calibration Point       | 2 mm       |
| Probe Tip to Sensor Z Calibration Point       | 2 mm       |
| Recommended Measurement Distance from Surface | 3 mm       |



Accredited by the Swiss Accreditation Service (SAS)  
The Swiss Accreditation Service is one of the signatories to the EA  
Multilateral Agreement for the recognition of calibration certificates

Accreditation No.: **SCS 0108**

Client **PC Test**

Certificate No: **ES3-3263\_May15**

## CALIBRATION CERTIFICATE

Object **ES3DV3 - SN:3263**

Calibration procedure(s) **QA CAL-01.v9, QA CAL-23.v5, QA CAL-25.v6  
Calibration procedure for dosimetric E-field probes**

Calibration date: **May 20, 2015**

*BN ✓  
5/28/15*

This calibration certificate documents the traceability to national standards, which realize the physical units of measurements (SI).  
The measurements and the uncertainties with confidence probability are given on the following pages and are part of the certificate.

All calibrations have been conducted in the closed laboratory facility: environment temperature (22 ± 3)°C and humidity < 70%.

Calibration Equipment used (M&TE critical for calibration)

| Primary Standards          | ID              | Cal Date (Certificate No.)        | Scheduled Calibration  |
|----------------------------|-----------------|-----------------------------------|------------------------|
| Power meter E4419B         | GB41293874      | 01-Apr-15 (No. 217-02128)         | Mar-16                 |
| Power sensor E4412A        | MY41498087      | 01-Apr-15 (No. 217-02128)         | Mar-16                 |
| Reference 3 dB Attenuator  | SN: S5054 (3c)  | 01-Apr-15 (No. 217-02129)         | Mar-16                 |
| Reference 20 dB Attenuator | SN: S5277 (20x) | 01-Apr-15 (No. 217-02132)         | Mar-16                 |
| Reference 30 dB Attenuator | SN: S5129 (30b) | 01-Apr-15 (No. 217-02133)         | Mar-16                 |
| Reference Probe ES3DV2     | SN: 3013        | 30-Dec-14 (No. ES3-3013_Dec14)    | Dec-15                 |
| DAE4                       | SN: 660         | 14-Jan-15 (No. DAE4-660_Jan15)    | Jan-16                 |
| Secondary Standards        | ID              | Check Date (in house)             | Scheduled Check        |
| RF generator HP 8648C      | US3642U01700    | 4-Aug-99 (in house check Apr-13)  | In house check: Apr-16 |
| Network Analyzer HP 8753E  | US37390585      | 18-Oct-01 (in house check Oct-14) | In house check: Oct-15 |

|   |                              |  |                      |
|---|------------------------------|--|----------------------|
| Calibrated by:  | Name<br><b>Leif Klysner</b>  | Function<br><b>Laboratory Technician</b> | Signature<br>        |
| Approved by:  | Name<br><b>Katja Pokovic</b> | Function<br><b>Technical Manager</b>     |                      |
| This calibration certificate shall not be reproduced except in full without written approval of the laboratory. |                              |  | Issued: May 19, 2015 |



Accredited by the Swiss Accreditation Service (SAS)

Accreditation No.: **SCS 0108**

The Swiss Accreditation Service is one of the signatories to the EA  
Multilateral Agreement for the recognition of calibration certificates

**Glossary:**

|                       |   |
|-----------------------|---|
| TSL                   | tissue simulating liquid  |
| NORM <sub>x,y,z</sub> | sensitivity in free space   |
| ConvF                 | sensitivity in TSL / NORM <sub>x,y,z</sub>  |
| DCP                   | diode compression point   |
| CF                    | crest factor (1/duty_cycle) of the RF signal  |
| A, B, C, D            | modulation dependent linearization parameters   |
| Polarization φ        | φ rotation around probe axis  |
| Polarization ϑ        | ϑ rotation around an axis that is in the plane normal to probe axis (at measurement center),<br>i.e., ϑ = 0 is normal to probe axis |
| Connector Angle       | information used in DASY system to align probe sensor X to the robot coordinate system  |

**Calibration is Performed According to the Following Standards:**

- a) IEEE Std 1528-2013, "IEEE Recommended Practice for Determining the Peak Spatial-Averaged Specific Absorption Rate (SAR) in the Human Head from Wireless Communications Devices: Measurement Techniques", June 2013
- b) IEC 62209-1, "Procedure to measure the Specific Absorption Rate (SAR) for hand-held devices used in close proximity to the ear (frequency range of 300 MHz to 3 GHz)", February 2005

**Methods Applied and Interpretation of Parameters:**

- *NORM<sub>x,y,z</sub>*: Assessed for E-field polarization ϑ = 0 (f ≤ 900 MHz in TEM-cell; f > 1800 MHz: R22 waveguide). *NORM<sub>x,y,z</sub>* are only intermediate values, i.e., the uncertainties of *NORM<sub>x,y,z</sub>* does not affect the E<sup>2</sup>-field uncertainty inside TSL (see below *ConvF*).
- *NORM(f)<sub>x,y,z</sub>* = *NORM<sub>x,y,z</sub>* \* *frequency\_response* (see Frequency Response Chart). This linearization is implemented in DASY4 software versions later than 4.2. The uncertainty of the frequency response is included in the stated uncertainty of *ConvF*.
- *DCP<sub>x,y,z</sub>*: DCP are numerical linearization parameters assessed based on the data of power sweep with CW signal (no uncertainty required). DCP does not depend on frequency nor media.
- *PAR*: PAR is the Peak to Average Ratio that is not calibrated but determined based on the signal characteristics
- *A<sub>x,y,z</sub>*; *B<sub>x,y,z</sub>*; *C<sub>x,y,z</sub>*; *D<sub>x,y,z</sub>*; *VR<sub>x,y,z</sub>*; *A, B, C, D* are numerical linearization parameters assessed based on the data of power sweep for specific modulation signal. The parameters do not depend on frequency nor media. *VR* is the maximum calibration range expressed in RMS voltage across the diode.
- *ConvF* and *Boundary Effect Parameters*: Assessed in flat phantom using E-field (or Temperature Transfer Standard for f ≤ 800 MHz) and inside waveguide using analytical field distributions based on power measurements for f > 800 MHz. The same setups are used for assessment of the parameters applied for boundary compensation (alpha, depth) of which typical uncertainty values are given. These parameters are used in DASY4 software to improve probe accuracy close to the boundary. The sensitivity in TSL corresponds to *NORM<sub>x,y,z</sub>* \* *ConvF* whereby the uncertainty corresponds to that given for *ConvF*. A frequency dependent *ConvF* is used in DASY version 4.4 and higher which allows extending the validity from ± 50 MHz to ± 100 MHz.
- *Spherical isotropy (3D deviation from isotropy)*: in a field of low gradients realized using a flat phantom exposed by a patch antenna.
- *Sensor Offset*: The sensor offset corresponds to the offset of virtual measurement center from the probe tip (on probe axis). No tolerance required.
- *Connector Angle*: The angle is assessed using the information gained by determining the *NORM<sub>x</sub>* (no uncertainty required).

# Probe ES3DV3

## SN:3263

Manufactured: January 25, 2010  
Calibrated: May 20, 2015

Calibrated for DASY/EASY Systems  
(Note: non-compatible with DASY2 system!)

## DASY/EASY - Parameters of Probe: ES3DV3 - SN:3263

### Basic Calibration Parameters

|   | Sensor X | Sensor Y | Sensor Z | Unc (k=2)     |
|---|----------|----------|----------|---------------|
| Norm ( $\mu\text{V}/(\text{V}/\text{m})^2$ ) <sup>A</sup> | 1.21     | 1.25     | 1.13     | $\pm 10.1 \%$ |
| DCP (mV) <sup>B</sup>                                     | 106.1    | 103.6    | 108.3    |               |

### Modulation Calibration Parameters

| UID           | Communication System Name                     |   | A<br>dB | B<br>dB $\sqrt{\mu\text{V}}$ | C    | D<br>dB | VR<br>mV | Unc <sup>E</sup><br>(k=2) |
|---------------|---|---|---------|------------------------------|------|---------|----------|---------------------------|
| 0             | CW  | X | 0.0     | 0.0                          | 1.0  | 0.00    | 205.3    | $\pm 3.3 \%$              |
|               |   | Y | 0.0     | 0.0                          | 1.0  |         | 207.3    |                           |
|               |   | Z | 0.0     | 0.0                          | 1.0  |         | 199.5    |                           |
| 10010-<br>CAA | SAR Validation (Square, 100ms, 10ms)          | X | 1.83    | 58.4                         | 9.4  | 10.00   | 41.2     | $\pm 1.4 \%$              |
|               |   | Y | 3.88    | 63.3                         | 12.9 |         | 47.5     |                           |
|               |   | Z | 1.42    | 56.8                         | 8.7  |         | 39.5     |                           |
| 10011-<br>CAB | UMTS-FDD (WCDMA)                              | X | 3.27    | 67.4                         | 18.6 | 2.91    | 140.1    | $\pm 0.7 \%$              |
|               |   | Y | 3.39    | 67.5                         | 18.7 |         | 142.7    |                           |
|               |   | Z | 3.32    | 67.6                         | 18.6 |         | 136.9    |                           |
| 10012-<br>CAB | IEEE 802.11b WiFi 2.4 GHz (DSSS, 1 Mbps)      | X | 2.85    | 68.8                         | 18.8 | 1.87    | 142.2    | $\pm 0.7 \%$              |
|               |   | Y | 3.38    | 70.7                         | 19.5 |         | 144.8    |                           |
|               |   | Z | 3.07    | 70.0                         | 19.1 |         | 138.1    |                           |
| 10013-<br>CAB | IEEE 802.11g WiFi 2.4 GHz (DSSS-OFDM, 6 Mbps) | X | 10.99   | 70.8                         | 23.4 | 9.46    | 135.9    | $\pm 2.5 \%$              |
|               |   | Y | 11.36   | 70.3                         | 22.8 |         | 124.7    |                           |
|               |   | Z | 10.57   | 70.0                         | 22.9 |         | 129.4    |                           |
| 10021-<br>DAB | GSM-FDD (TDMA, GMSK)                          | X | 9.38    | 84.7                         | 22.1 | 9.39    | 139.8    | $\pm 1.9 \%$              |
|               |   | Y | 27.79   | 100.0                        | 28.7 |         | 129.4    |                           |
|               |   | Z | 9.29    | 86.8                         | 23.8 |         | 134.5    |                           |
| 10023-<br>DAB | GPRS-FDD (TDMA, GMSK, TN 0)                   | X | 9.63    | 84.9                         | 22.1 | 9.57    | 134.1    | $\pm 2.5 \%$              |
|               |   | Y | 25.29   | 98.2                         | 28.2 |         | 124.0    |                           |
|               |   | Z | 9.65    | 87.7                         | 24.3 |         | 128.2    |                           |
| 10024-<br>DAB | GPRS-FDD (TDMA, GMSK, TN 0-1)                 | X | 16.20   | 88.9                         | 21.0 | 6.56    | 145.2    | $\pm 1.4 \%$              |
|               |   | Y | 41.82   | 99.7                         | 25.6 |         | 128.5    |                           |
|               |   | Z | 24.57   | 96.8                         | 24.1 |         | 142.0    |                           |
| 10027-<br>DAB | GPRS-FDD (TDMA, GMSK, TN 0-1-2)               | X | 55.77   | 99.6                         | 22.1 | 4.80    | 138.5    | $\pm 2.2 \%$              |
|               |   | Y | 53.39   | 99.7                         | 23.9 |         | 140.5    |                           |
|               |   | Z | 40.28   | 99.6                         | 23.2 |         | 134.3    |                           |
| 10028-<br>DAB | GPRS-FDD (TDMA, GMSK, TN 0-1-2-3)             | X | 81.43   | 99.8                         | 20.7 | 3.55    | 148.6    | $\pm 1.7 \%$              |
|               |   | Y | 60.49   | 99.7                         | 22.9 |         | 146.0    |                           |
|               |   | Z | 62.69   | 99.6                         | 21.2 |         | 145.0    |                           |
| 10032-<br>CAA | IEEE 802.15.1 Bluetooth (GFSK, DH5)           | X | 96.06   | 93.7                         | 16.0 | 1.16    | 140.3    | $\pm 1.9 \%$              |
|               |   | Y | 77.08   | 99.9                         | 20.1 |         | 149.0    |                           |
|               |   | Z | 99.64   | 99.9                         | 18.6 |         | 138.0    |                           |
| 10100-<br>CAB | LTE-FDD (SC-FDMA, 100% RB, 20 MHz, QPSK)      | X | 6.24    | 67.2                         | 19.6 | 5.67    | 131.7    | $\pm 1.4 \%$              |
|               |   | Y | 6.39    | 67.3                         | 19.5 |         | 133.8    |                           |
|               |   | Z | 6.19    | 67.2                         | 19.6 |         | 126.8    |                           |

|           |  |   |       |      |      |      |       |        |
|-----------|--|---|-------|------|------|------|-------|--------|
| 10103-CAB | LTE-TDD (SC-FDMA, 100% RB, 20 MHz, QPSK) | X | 10.13 | 76.3 | 26.6 | 9.29 | 142.6 | ±2.7 % |
|           |  | Y | 12.07 | 77.9 | 26.6 |      | 138.9 |        |
|           |  | Z | 9.41  | 74.3 | 25.6 |      | 134.1 |        |
| 10108-CAC | LTE-FDD (SC-FDMA, 100% RB, 10 MHz, QPSK) | X | 6.13  | 66.9 | 19.5 | 5.80 | 129.6 | ±1.4 % |
|           |  | Y | 6.35  | 67.1 | 19.5 |      | 133.7 |        |
|           |  | Z | 6.39  | 68.0 | 20.1 |      | 150.0 |        |
| 10117-CAB | IEEE 802.11n (HT Mixed, 13.5 Mbps, BPSK) | X | 10.34 | 69.6 | 21.7 | 8.07 | 147.0 | ±1.9 % |
|           |  | Y | 10.05 | 68.3 | 20.9 |      | 123.4 |        |
|           |  | Z | 10.08 | 69.1 | 21.3 |      | 138.2 |        |
| 10151-CAB | LTE-TDD (SC-FDMA, 50% RB, 20 MHz, QPSK)  | X | 9.44  | 75.3 | 26.3 | 9.28 | 137.0 | ±3.5 % |
|           |  | Y | 11.36 | 76.9 | 26.3 |      | 134.5 |        |
|           |  | Z | 8.85  | 73.5 | 25.3 |      | 130.3 |        |
| 10154-CAC | LTE-FDD (SC-FDMA, 50% RB, 10 MHz, QPSK)  | X | 5.79  | 66.2 | 19.2 | 5.75 | 126.9 | ±1.2 % |
|           |  | Y | 6.05  | 66.5 | 19.3 |      | 130.9 |        |
|           |  | Z | 5.92  | 66.9 | 19.5 |      | 145.5 |        |
| 10160-CAB | LTE-FDD (SC-FDMA, 50% RB, 15 MHz, QPSK)  | X | 6.25  | 66.9 | 19.5 | 5.82 | 131.8 | ±1.4 % |
|           |  | Y | 6.47  | 67.0 | 19.5 |      | 135.4 |        |
|           |  | Z | 6.09  | 66.5 | 19.3 |      | 127.5 |        |
| 10169-CAB | LTE-FDD (SC-FDMA, 1 RB, 20 MHz, QPSK)    | X | 4.78  | 66.7 | 19.7 | 5.73 | 130.0 | ±1.2 % |
|           |  | Y | 5.14  | 66.7 | 19.5 |      | 135.0 |        |
|           |  | Z | 4.83  | 67.1 | 19.9 |      | 147.9 |        |
| 10172-CAB | LTE-TDD (SC-FDMA, 1 RB, 20 MHz, QPSK)    | X | 8.63  | 80.4 | 29.1 | 9.21 | 147.7 | ±2.7 % |
|           |  | Y | 9.72  | 78.5 | 27.2 |      | 123.9 |        |
|           |  | Z | 7.63  | 76.7 | 27.2 |      | 142.5 |        |
| 10175-CAC | LTE-FDD (SC-FDMA, 1 RB, 10 MHz, QPSK)    | X | 4.75  | 66.6 | 19.6 | 5.72 | 128.2 | ±1.2 % |
|           |  | Y | 5.12  | 66.6 | 19.5 |      | 134.3 |        |
|           |  | Z | 4.87  | 67.1 | 19.9 |      | 148.0 |        |
| 10181-CAB | LTE-FDD (SC-FDMA, 1 RB, 15 MHz, QPSK)    | X | 4.76  | 66.6 | 19.6 | 5.72 | 127.9 | ±1.2 % |
|           |  | Y | 5.12  | 66.6 | 19.5 |      | 134.5 |        |
|           |  | Z | 4.87  | 67.3 | 20.0 |      | 147.0 |        |
| 10196-CAB | IEEE 802.11n (HT Mixed, 6.5 Mbps, BPSK)  | X | 9.87  | 69.1 | 21.6 | 8.10 | 135.8 | ±2.2 % |
|           |  | Y | 10.19 | 69.1 | 21.4 |      | 145.3 |        |
|           |  | Z | 9.65  | 68.8 | 21.3 |      | 130.5 |        |
| 10225-CAB | UMTS-FDD (HSPA+)                         | X | 6.90  | 67.2 | 19.5 | 5.97 | 139.2 | ±1.7 % |
|           |  | Y | 7.22  | 67.3 | 19.6 |      | 148.0 |        |
|           |  | Z | 6.75  | 67.0 | 19.4 |      | 134.1 |        |
| 10237-CAB | LTE-TDD (SC-FDMA, 1 RB, 10 MHz, QPSK)    | X | 8.68  | 80.6 | 29.2 | 9.21 | 148.0 | ±3.0 % |
|           |  | Y | 9.82  | 78.8 | 27.3 |      | 125.0 |        |
|           |  | Z | 7.85  | 77.6 | 27.7 |      | 143.5 |        |
| 10252-CAB | LTE-TDD (SC-FDMA, 50% RB, 10 MHz, QPSK)  | X | 8.56  | 73.7 | 25.6 | 9.24 | 126.6 | ±3.5 % |
|           |  | Y | 10.58 | 76.0 | 25.9 |      | 126.3 |        |
|           |  | Z | 8.84  | 74.8 | 26.1 |      | 146.7 |        |
| 10267-CAB | LTE-TDD (SC-FDMA, 100% RB, 10 MHz, QPSK) | X | 9.24  | 74.6 | 25.9 | 9.30 | 133.6 | ±3.3 % |
|           |  | Y | 11.38 | 76.9 | 26.2 |      | 134.3 |        |
|           |  | Z | 8.79  | 73.2 | 25.1 |      | 128.6 |        |

|           |   |   |       |      |      |      |       |        |
|-----------|---|---|-------|------|------|------|-------|--------|
| 10275-CAB | UMTS-FDD (HSUPA, Subtest 5, 3GPP Rel8.4)                      | X | 4.39  | 67.0 | 18.9 | 3.96 | 143.8 | ±0.9 % |
|           |   | Y | 4.55  | 67.1 | 18.8 |      | 147.3 |        |
|           |   | Z | 4.42  | 67.4 | 19.0 |      | 139.9 |        |
| 10291-AAB | CDMA2000, RC3, SO55, Full Rate                                | X | 3.59  | 67.2 | 18.9 | 3.46 | 132.2 | ±0.5 % |
|           |   | Y | 3.68  | 66.7 | 18.5 |      | 136.0 |        |
|           |   | Z | 3.57  | 67.1 | 18.6 |      | 128.5 |        |
| 10292-AAB | CDMA2000, RC3, SO32, Full Rate                                | X | 3.50  | 67.0 | 18.7 | 3.39 | 134.0 | ±0.7 % |
|           |   | Y | 3.62  | 66.6 | 18.4 |      | 138.6 |        |
|           |   | Z | 3.50  | 67.2 | 18.7 |      | 129.8 |        |
| 10297-AAA | LTE-FDD (SC-FDMA, 50% RB, 20 MHz, QPSK)                       | X | 6.11  | 66.8 | 19.4 | 5.81 | 127.7 | ±1.4 % |
|           |   | Y | 6.33  | 67.0 | 19.5 |      | 132.1 |        |
|           |   | Z | 6.28  | 67.6 | 19.9 |      | 146.6 |        |
| 10311-AAA | LTE-FDD (SC-FDMA, 100% RB, 15 MHz, QPSK)                      | X | 6.71  | 67.5 | 19.9 | 6.06 | 134.2 | ±1.7 % |
|           |   | Y | 6.93  | 67.7 | 19.9 |      | 138.0 |        |
|           |   | Z | 6.57  | 67.2 | 19.6 |      | 128.0 |        |
| 10400-AAC | IEEE 802.11ac WiFi (20MHz, 64-QAM, 99pc duty cycle)           | X | 10.17 | 69.5 | 21.9 | 8.37 | 138.5 | ±2.5 % |
|           |   | Y | 10.55 | 69.5 | 21.8 |      | 148.0 |        |
|           |   | Z | 9.92  | 69.0 | 21.6 |      | 132.5 |        |
| 10403-AAB | CDMA2000 (1xEV-DO, Rev. 0)                                    | X | 4.79  | 69.2 | 19.1 | 3.76 | 144.1 | ±0.7 % |
|           |   | Y | 4.71  | 67.0 | 18.2 |      | 129.2 |        |
|           |   | Z | 4.72  | 69.3 | 19.2 |      | 139.3 |        |
| 10404-AAB | CDMA2000 (1xEV-DO, Rev. A)                                    | X | 4.69  | 69.2 | 19.2 | 3.77 | 142.1 | ±0.7 % |
|           |   | Y | 4.71  | 67.5 | 18.5 |      | 126.7 |        |
|           |   | Z | 4.51  | 68.6 | 18.8 |      | 137.3 |        |
| 10415-AAA | IEEE 802.11b WiFi 2.4 GHz (DSSS, 1 Mbps, 99pc duty cycle)     | X | 2.55  | 68.0 | 18.5 | 1.54 | 141.7 | ±0.7 % |
|           |   | Y | 2.67  | 68.4 | 18.6 |      | 144.0 |        |
|           |   | Z | 2.98  | 70.8 | 19.5 |      | 138.0 |        |
| 10416-AAA | IEEE 802.11g WiFi 2.4 GHz (ERP-OFDM, 6 Mbps, 99pc duty cycle) | X | 10.01 | 69.3 | 21.8 | 8.23 | 137.3 | ±2.5 % |
|           |   | Y | 10.31 | 69.3 | 21.6 |      | 146.0 |        |
|           |   | Z | 9.69  | 68.8 | 21.4 |      | 129.9 |        |

The reported uncertainty of measurement is stated as the standard uncertainty of measurement multiplied by the coverage factor  $k=2$ , which for a normal distribution corresponds to a coverage probability of approximately 95%.

<sup>A</sup> The uncertainties of NormX,Y,Z do not affect the E<sup>2</sup>-field uncertainty inside TSL (see Pages 7 and 8).

<sup>B</sup> Numerical linearization parameter: uncertainty not required.

<sup>E</sup> Uncertainty is determined using the max. deviation from linear response applying rectangular distribution and is expressed for the square of the field value.

## DASY/EASY - Parameters of Probe: ES3DV3 - SN:3263

### Calibration Parameter Determined in Head Tissue Simulating Media

| f (MHz) <sup>C</sup> | Relative Permittivity <sup>F</sup> | Conductivity (S/m) <sup>F</sup> | ConvF X | ConvF Y | ConvF Z | Alpha <sup>G</sup> | Depth (mm) <sup>G</sup> | Unct. (k=2) |
|----------------------|------------------------------------|---------------------------------|---------|---------|---------|--------------------|-------------------------|-------------|
| 750                  | 41.9                               | 0.89                            | 6.27    | 6.27    | 6.27    | 0.29               | 1.87                    | ± 12.0 %    |
| 835                  | 41.5                               | 0.90                            | 6.18    | 6.18    | 6.18    | 0.49               | 1.42                    | ± 12.0 %    |
| 1750                 | 40.1                               | 1.37                            | 5.27    | 5.27    | 5.27    | 0.49               | 1.46                    | ± 12.0 %    |
| 1900                 | 40.0                               | 1.40                            | 4.96    | 4.96    | 4.96    | 0.66               | 1.28                    | ± 12.0 %    |
| 2300                 | 39.5                               | 1.67                            | 4.63    | 4.63    | 4.63    | 0.58               | 1.41                    | ± 12.0 %    |
| 2450                 | 39.2                               | 1.80                            | 4.40    | 4.40    | 4.40    | 0.71               | 1.34                    | ± 12.0 %    |
| 2600                 | 39.0                               | 1.96                            | 4.25    | 4.25    | 4.25    | 0.80               | 1.25                    | ± 12.0 %    |

<sup>C</sup> Frequency validity above 300 MHz of ± 100 MHz only applies for DASY v4.4 and higher (see Page 2), else it is restricted to ± 50 MHz. The uncertainty is the RSS of the ConvF uncertainty at calibration frequency and the uncertainty for the indicated frequency band. Frequency validity below 300 MHz is ± 10, 25, 40, 50 and 70 MHz for ConvF assessments at 30, 64, 128, 150 and 220 MHz respectively. Above 5 GHz frequency validity can be extended to ± 110 MHz.

<sup>F</sup> At frequencies below 3 GHz, the validity of tissue parameters ( $\epsilon$  and  $\sigma$ ) can be relaxed to ± 10% if liquid compensation formula is applied to measured SAR values. At frequencies above 3 GHz, the validity of tissue parameters ( $\epsilon$  and  $\sigma$ ) is restricted to ± 5%. The uncertainty is the RSS of the ConvF uncertainty for indicated target tissue parameters.

<sup>G</sup> Alpha/Depth are determined during calibration. SPEAG warrants that the remaining deviation due to the boundary effect after compensation is always less than ± 1% for frequencies below 3 GHz and below ± 2% for frequencies between 3-6 GHz at any distance larger than half the probe tip diameter from the boundary.

## DASY/EASY - Parameters of Probe: ES3DV3 - SN:3263

### Calibration Parameter Determined in Body Tissue Simulating Media

| f (MHz) <sup>C</sup> | Relative Permittivity <sup>F</sup> | Conductivity (S/m) <sup>F</sup> | ConvF X | ConvF Y | ConvF Z | Alpha <sup>G</sup> | Depth (mm) <sup>G</sup> | Unct. (k=2) |
|----------------------|------------------------------------|---------------------------------|---------|---------|---------|--------------------|-------------------------|-------------|
| 750                  | 55.5                               | 0.96                            | 6.07    | 6.07    | 6.07    | 0.53               | 1.42                    | ± 12.0 %    |
| 835                  | 55.2                               | 0.97                            | 6.08    | 6.08    | 6.08    | 0.57               | 1.36                    | ± 12.0 %    |
| 1750                 | 53.4                               | 1.49                            | 4.88    | 4.88    | 4.88    | 0.54               | 1.50                    | ± 12.0 %    |
| 1900                 | 53.3                               | 1.52                            | 4.66    | 4.66    | 4.66    | 0.56               | 1.51                    | ± 12.0 %    |
| 2300                 | 52.9                               | 1.81                            | 4.42    | 4.42    | 4.42    | 0.69               | 1.33                    | ± 12.0 %    |
| 2450                 | 52.7                               | 1.95                            | 4.28    | 4.28    | 4.28    | 0.80               | 1.08                    | ± 12.0 %    |
| 2600                 | 52.5                               | 2.16                            | 4.11    | 4.11    | 4.11    | 0.80               | 1.09                    | ± 12.0 %    |

<sup>C</sup> Frequency validity above 300 MHz of ± 100 MHz only applies for DASY v4.4 and higher (see Page 2), else it is restricted to ± 50 MHz. The uncertainty is the RSS of the ConvF uncertainty at calibration frequency and the uncertainty for the indicated frequency band. Frequency validity below 300 MHz is ± 10, 25, 40, 50 and 70 MHz for ConvF assessments at 30, 64, 128, 150 and 220 MHz respectively. Above 5 GHz frequency validity can be extended to ± 110 MHz.

<sup>F</sup> At frequencies below 3 GHz, the validity of tissue parameters ( $\epsilon$  and  $\sigma$ ) can be relaxed to ± 10% if liquid compensation formula is applied to measured SAR values. At frequencies above 3 GHz, the validity of tissue parameters ( $\epsilon$  and  $\sigma$ ) is restricted to ± 5%. The uncertainty is the RSS of the ConvF uncertainty for indicated target tissue parameters.

<sup>G</sup> Alpha/Depth are determined during calibration. SPEAG warrants that the remaining deviation due to the boundary effect after compensation is always less than ± 1% for frequencies below 3 GHz and below ± 2% for frequencies between 3-6 GHz at any distance larger than half the probe tip diameter from the boundary.

### Frequency Response of E-Field (TEM-Cell:ifi110 EXX, Waveguide: R22)

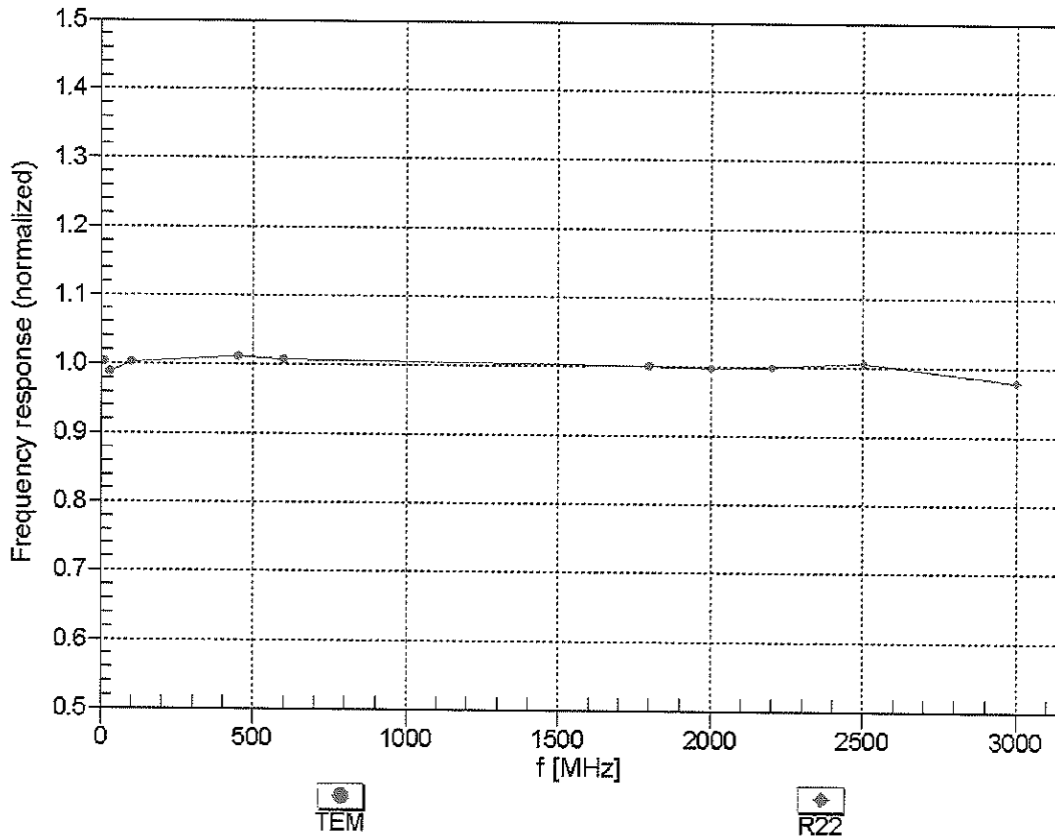

Uncertainty of Frequency Response of E-field:  $\pm 6.3\%$  (k=2)

### Receiving Pattern ( $\phi$ ), $\theta = 0^\circ$

f=600 MHz,TEM

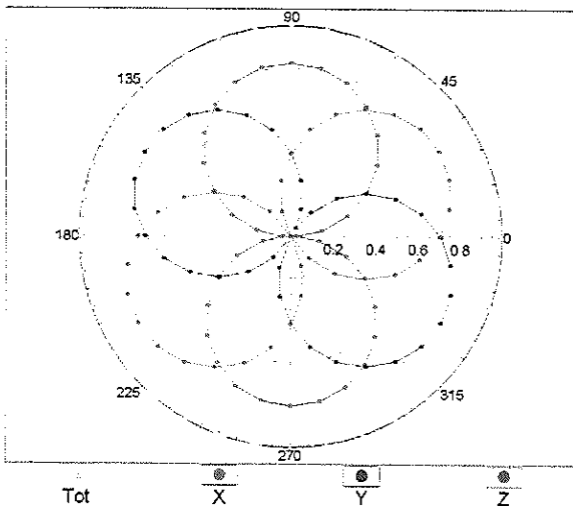

f=1800 MHz,R22

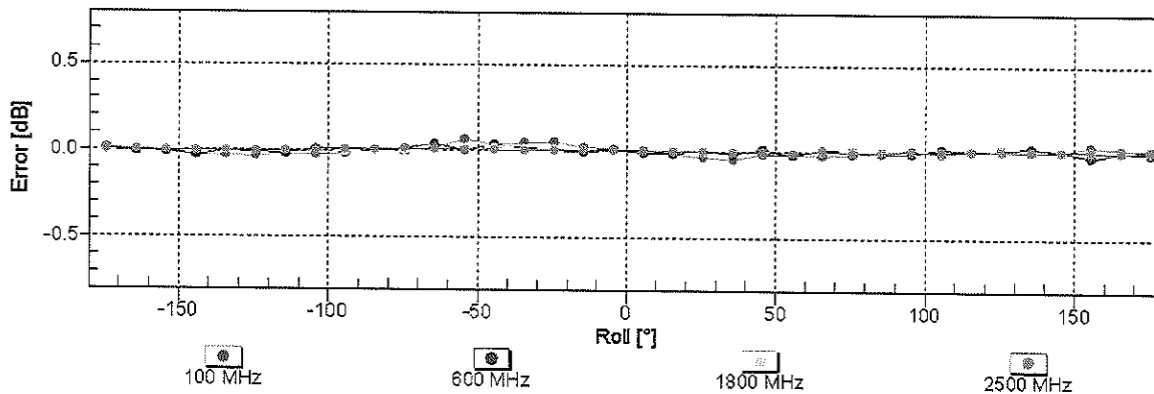
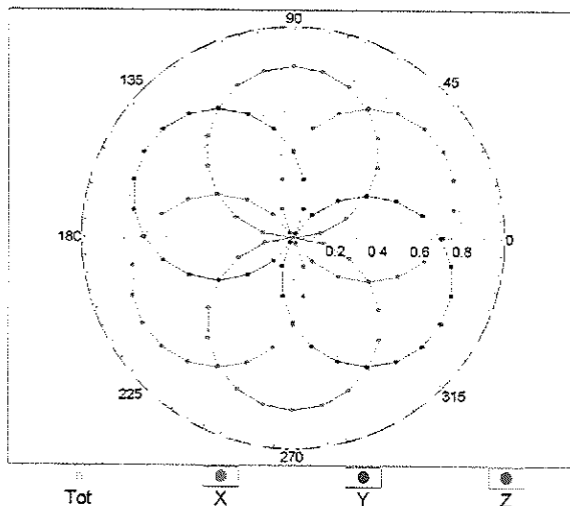

Uncertainty of Axial Isotropy Assessment:  $\pm 0.5\%$  (k=2)

### Dynamic Range $f(SAR_{head})$ (TEM cell, $f_{eval} = 1900$ MHz)

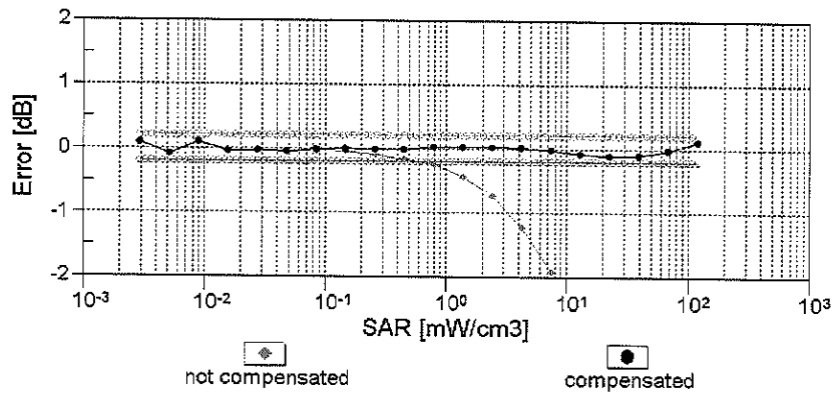
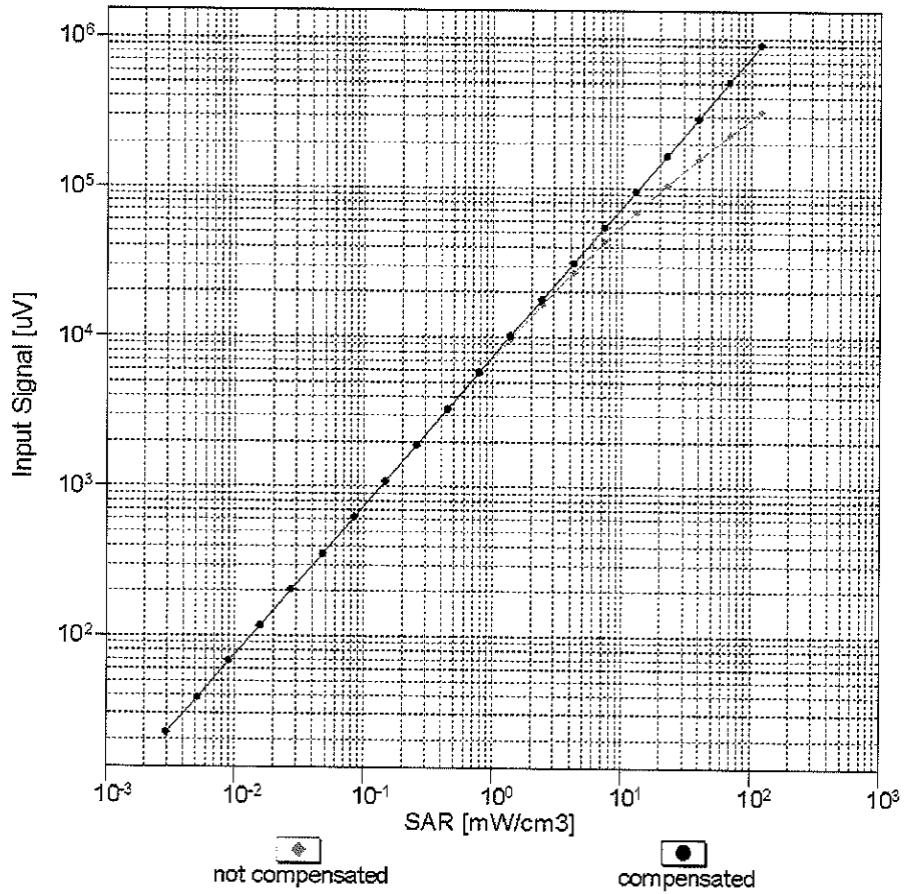

Uncertainty of Linearity Assessment:  $\pm 0.6\%$  ( $k=2$ )

# Conversion Factor Assessment

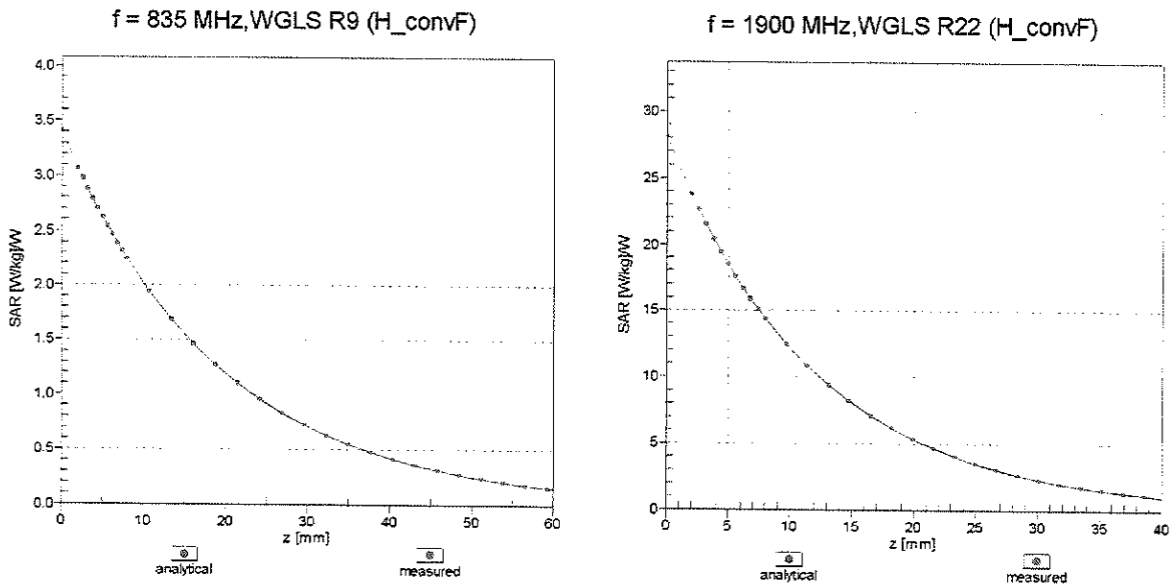

## Deviation from Isotropy in Liquid Error ( $\phi, \theta$ ), f = 900 MHz

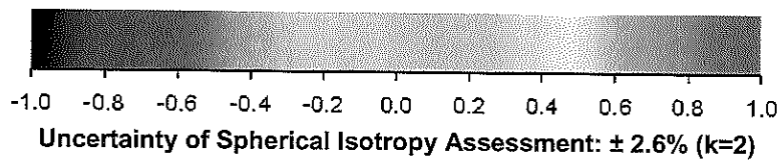
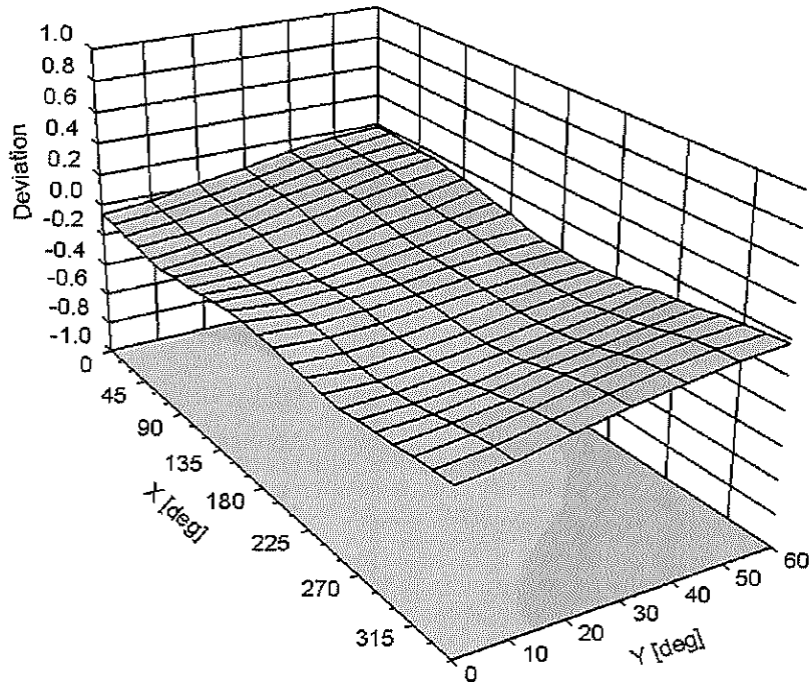

## DASY/EASY - Parameters of Probe: ES3DV3 - SN:3263

### Other Probe Parameters

|   |            |
|---|------------|
| Sensor Arrangement                            | Triangular |
| Connector Angle (°)                           | 65.6       |
| Mechanical Surface Detection Mode             | enabled    |
| Optical Surface Detection Mode                | disabled   |
| Probe Overall Length                          | 337 mm     |
| Probe Body Diameter                           | 10 mm      |
| Tip Length                                    | 10 mm      |
| Tip Diameter                                  | 4 mm       |
| Probe Tip to Sensor X Calibration Point       | 2 mm       |
| Probe Tip to Sensor Y Calibration Point       | 2 mm       |
| Probe Tip to Sensor Z Calibration Point       | 2 mm       |
| Recommended Measurement Distance from Surface | 3 mm       |

## APPENDIX D: SAR TISSUE SPECIFICATIONS

Measurement Procedure for Tissue verification:



- 1) The network analyzer and probe system was configured and calibrated.
- 2) The probe was immersed in the tissue. The tissue was placed in a nonmetallic container. Trapped air bubbles beneath the flange were minimized by placing the probe at a slight angle.
- 3) The complex admittance with respect to the probe aperture was measured
- 4) The complex relative permittivity  $\epsilon$  can be calculated from the below equation (Pournaropoulos and Misra):

$$Y = \frac{j2\omega\epsilon_r\epsilon_0}{[\ln(b/a)]^2} \int_a^b \int_a^b \int_0^\pi \cos\phi' \frac{\exp[-j\omega r(\mu_0\epsilon_r'\epsilon_0)^{1/2}]}{r} d\phi' d\rho' d\rho$$

where  $Y$  is the admittance of the probe in contact with the sample, the primed and unprimed coordinates refer to source and observation points, respectively,  $r^2 = \rho^2 + \rho'^2 - 2\rho\rho'\cos\phi'$ ,  $\omega$  is the angular frequency, and  $j = \sqrt{-1}$ .

**Table D-1  
Composition of the Tissue Equivalent Matter**

| Frequency (MHz)           | 1750 | 1750 |
|---------------------------|------|------|
| Tissue                    | Head | Body |
| Ingredients (% by weight) |      |      |
| DGBE                      | 47   | 31   |
| NaCl                      | 0.4  | 0.2  |
| Water                     | 52.6 | 68.8 |

|                                    |   |                              |   |                                 |
|------------------------------------|---|------------------------------|---|---------------------------------|
| FCC ID: ACJEB3910A                 |  | <b>SAR EVALUATION REPORT</b> |  | Reviewed by:<br>Quality Manager |
| Test Dates:<br>10/28/15 - 11/03/15 | DUT Type:<br>Portable Handset   |                              |   | APPENDIX D:<br>Page 1 of 1      |

## APPENDIX E: SAR SYSTEM VALIDATION

Per FCC KDB 865664 D02v01, SAR system validation status should be documented to confirm measurement accuracy. The SAR systems (including SAR probes, system components and software versions) used for this device were validated against its performance specifications prior to the SAR measurements. Reference dipoles were used with the required tissue- equivalent media for system validation, according to the procedures outlined in FCC KDB 865664 D01v01r04 and IEEE 1528-2013. Since SAR probe calibrations are frequency dependent, each probe calibration point was validated at a frequency within the valid frequency range of the probe calibration point, using the system that normally operates with the probe for routine SAR measurements and according to the required tissue-equivalent media.

A tabulated summary of the system validation status including the validation date(s), measurement frequencies, SAR probes and tissue dielectric parameters has been included.



**Table E-I**  
**SAR System Validation Summary – 1g**

| SAR SYSTEM # | FREQ. [MHz] | DATE      | PROBE SN | PROBE TYPE | PROBE CAL. POINT |      | COND. | PERM.             | CW VALIDATION |                 |                | MOD. VALIDATION |             |     |
|--------------|-------------|-----------|----------|------------|------------------|------|-------|-------------------|---------------|-----------------|----------------|-----------------|-------------|-----|
|              |             |           |          |            |                  |      | (σ)   | (ε <sub>r</sub> ) | SENSITIVITY   | PROBE LINEARITY | PROBE ISOTROPY | MOD. TYPE       | DUTY FACTOR | PAR |
| I            | 1750        | 5/31/2015 | 3213     | ES3DV3     | 1750             | Head | 1.367 | 39.144            | PASS          | PASS            | PASS           | N/A             | N/A         | N/A |
| H            | 1750        | 7/15/2015 | 3263     | ES3DV3     | 1750             | Body | 1.471 | 51.582            | PASS          | PASS            | PASS           | N/A             | N/A         | N/A |

**Table E-II**  
**SAR System Validation Summary – 10g**

| SAR SYSTEM # | FREQ. [MHz] | DATE      | PROBE SN | PROBE TYPE | PROBE CAL. POINT |      | COND. | PERM.             | CW VALIDATION |                 |                | MOD. VALIDATION |             |     |
|--------------|-------------|-----------|----------|------------|------------------|------|-------|-------------------|---------------|-----------------|----------------|-----------------|-------------|-----|
|              |             |           |          |            |                  |      | (σ)   | (ε <sub>r</sub> ) | SENSITIVITY   | PROBE LINEARITY | PROBE ISOTROPY | MOD. TYPE       | DUTY FACTOR | PAR |
| H            | 1750        | 7/15/2015 | 3263     | ES3DV3     | 1750             | Body | 1.471 | 51.582            | PASS          | PASS            | PASS           | N/A             | N/A         | N/A |

NOTE: While the probes have been calibrated for both CW and modulated signals, all measurements were performed using communication systems calibrated for CW signals only. Modulations in the table above represent test configurations for which the measurement system has been validated per FCC KDB Publication 865664 D01v01r04 for scenarios when CW probe calibrations are used with other signal types. SAR systems were validated for modulated signals with a periodic duty cycle, such as GMSK, or with a high peak to average ratio (>5 dB), such as OFDM according to FCC KDB Publication 865664 D01v01r04.

|                                    |   |                              |   |                                 |
|------------------------------------|---|------------------------------|---|---------------------------------|
| FCC ID: ACJEB3910A                 |  | <b>SAR EVALUATION REPORT</b> |  | Reviewed by:<br>Quality Manager |
| Test Dates:<br>10/28/15 - 11/03/15 | DUT Type:<br>Portable Handset   |                              |   | APPENDIX E:<br>Page 1 of 1      |