

ENGINEERING TEST REPORT

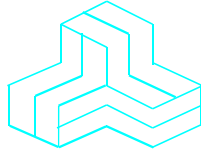

**Portable DVD/CD Player
MODEL NO.: DVD-LS55**

FCC ID: ACJDVDSL55

Applicant:

Matsushita Electric Industrial Co., Ltd.
1006 Oaza Kadoma
Kadoma, Osaka 571, Japan

Tested in Accordance With

**FCC Part 15, Subpart C, Section 15.239
Low Power Transmitters
Operation in the Frequency Band 88-108 MHz**

UltraTech's File No.: PAN-041FCC15C

This Test report is Issued under the Authority of
Tri M. Luu, Professional Engineer,
Vice President of Engineering
UltraTech Group of Labs

Date: April 26, 2004



Report Prepared by: Dan Huynh

Tested by: Hung Trinh, RF Technician

Issued Date: April 26, 2004

Test Dates: March 20 - April 26, 2004

- *The results in this Test Report apply only to the sample(s) tested, and the sample tested is randomly selected.*
- *This report must not be used by the client to claim product endorsement by NVLAP or any agency of the US Government.*

UltraTech

3000 Bristol Circle, Oakville, Ontario, Canada, L6H 6G4
Tel.: (905) 829-1570 Fax.: (905) 829-8050
Website: www.ultratech-labs.com, Email: vic@ultratech-labs.com, Email: tri@ultratech-labs.com



31040/SIT



C-1376



46390-2049



200093-0



SL2-IN-E-1119R



00-034



TABLE OF CONTENTS

| | | |
|-------------------|--|-----------|
| EXHIBIT 1. | SUBMITTAL CHECK LIST | 1 |
| EXHIBIT 2. | INTRODUCTION..... | 2 |
| 2.1. | SCOPE | 2 |
| 2.2. | RELATED SUBMITTAL(S)/GRANT(S)..... | 2 |
| 2.3. | NORMATIVE REFERENCES | 2 |
| EXHIBIT 3. | PERFORMANCE ASSESSMENT | 3 |
| 3.1. | CLIENT INFORMATION | 3 |
| 3.2. | EQUIPMENT UNDER TEST (EUT) INFORMATION | 3 |
| 3.3. | EUT'S TECHNICAL SPECIFICATIONS | 4 |
| 3.4. | LIST OF EUT'S PORTS | 4 |
| 3.5. | ANCILLARY EQUIPMENT | 5 |
| 3.6. | GENERAL TEST SETUP..... | 5 |
| EXHIBIT 4. | EUT OPERATING CONDITIONS AND CONFIGURATIONS DURING TESTS..... | 6 |
| 4.1. | CLIMATE TEST CONDITIONS | 6 |
| 4.2. | OPERATIONAL TEST CONDITIONS & ARRANGEMENT FOR TESTS | 6 |
| EXHIBIT 5. | SUMMARY OF TEST RESULTS..... | 7 |
| 5.1. | LOCATION OF TESTS..... | 7 |
| 5.2. | APPLICABILITY & SUMMARY OF EMC EMISSION TEST RESULTS | 7 |
| 5.3. | MODIFICATIONS INCORPORATED IN THE EUT FOR COMPLIANCE PURPOSES | 8 |
| EXHIBIT 6. | MEASUREMENTS, EXAMINATIONS & TEST DATA FOR EMC EMISSIONS | 9 |
| 6.1. | TEST PROCEDURES | 9 |
| 6.2. | MEASUREMENT UNCERTAINTIES | 9 |
| 6.3. | MEASUREMENT EQUIPMENT USED | 9 |
| 6.4. | ESSENTIAL/PRIMARY FUNCTIONS AS DECLARED BY THE MANUFACTURER..... | 9 |
| 6.5. | AC POWER LINE CONDUCTED EMISSIONS [§ 15.207]..... | 10 |
| 6.6. | OCCUPIED BANDWIDTH [§ 15.239(a)]..... | 16 |
| 6.7. | FIELD STRENGTH OF EMISSIONS INSIDE & OUTSIDE THE PERMITTED BAND 88-108 MHz [§ 15.239(b)&(c)] | 21 |
| EXHIBIT 7. | MEASUREMENT UNCERTAINTY | 23 |
| 7.1. | LINE CONDUCTED EMISSION MEASUREMENT UNCERTAINTY..... | 23 |
| 7.2. | RADIATED EMISSION MEASUREMENT UNCERTAINTY..... | 24 |
| EXHIBIT 8. | GENERAL TEST PROCEDURES..... | 25 |
| 8.1. | GENERAL TEST CONDITIONS..... | 25 |
| 8.2. | METHOD OF MEASUREMENTS - AC MAINS CONDUCTED EMISSIONS | 26 |
| 8.3. | SPURIOUS EMISSIONS (CONDUCTED & RADIATED) | 27 |

EXHIBIT 1. SUBMITTAL CHECK LIST

| Annex No. | Exhibit Type | Description of Contents | Quality Check (OK) |
|-----------|-------------------------|---|--------------------|
| -- | Test Report | Test report | OK |
| 1 | Test Setup Photos | Test Setup Photos | OK |
| 2 | External Photos of EUT | External EUT Photos | OK |
| 3 | Internal Photos of EUT | Internal EUT Photos | OK |
| 4 | Cover Letters | <ul style="list-style-type: none">▪ Letter from Ultratech for Certification Request▪ Letter from the Applicant to appoint Ultratech to act as an agent▪ Letter from the Applicant to request for Confidentiality Filing | OK |
| 5 | Attestation Statements | -- | -- |
| 6 | ID Label/Location Info | <ul style="list-style-type: none">▪ ID Label▪ Location of ID Label | OK |
| 7 | Block Diagrams | Block Diagram | OK |
| 8 | Schematic Diagrams | Schematics | OK |
| 9 | Parts List/Tune Up Info | Parts List | OK |
| 10 | Operational Description | Detailed Operational Description | OK |
| 11 | RF Exposure Info | N/A | N/A |
| 12 | Users Manual | Portable DVD/CD Player Operating Instructions | OK |

EXHIBIT 2. INTRODUCTION

2.1. SCOPE

| | |
|--------------------------------------|--|
| Reference: | FCC Part 15, Subpart C, Section 15.239 |
| Title: | Code of Federal Regulations (CFR), Title 47 - Telecommunication, Part 15 |
| Purpose of Test: | To gain FCC Certification Authorization for Low Power Licensed-Exempt Transmitters operating in the Frequency Band 88-108 MHz . |
| Test Procedures: | Both conducted and radiated emissions measurements were conducted in accordance with American National Standards Institute ANSI C63.4 - American National Standard for Methods of Measurement of Radio-Noise Emissions from Low-Voltage Electrical and Electronic Equipment in the Range of 9 kHz to 40 GHz. |
| Environmental Classification: | Residential Commercial, industrial or business environment. |

2.2. RELATED SUBMITTAL(S)/GRANT(S)

None.

2.3. NORMATIVE REFERENCES

| Publication | Year | Title |
|---------------------|--------------|---|
| FCC CFR Parts 0-19 | 2003 | Code of Federal Regulations, Title 47 – Telecommunication |
| ANSI C63.4 | 2003 | American National Standard for Methods of Measurement of Radio-Noise Emissions from Low-Voltage Electrical and Electronic Equipment in the Range of 9 kHz to 40 GHz |
| CISPR 22 & EN 55022 | 2002 2003 | Limits and Methods of Measurements of Radio Disturbance Characteristics of Information Technology Equipment |
| CISPR 16-1 | 1999 | Specification for Radio Disturbance and Immunity measuring apparatus and methods |

EXHIBIT 3. PERFORMANCE ASSESSMENT

3.1. CLIENT INFORMATION

| APPLICANT | |
|------------------------|---|
| Name: | Matsushita Electric Industrial Co., Ltd. |
| Address: | 1006 Oaza Kadoma Kadoma, Osaka 571, Japan |
| Contact Person: | Richard Mullen Phone #: 201-348-7758 Fax #: 201-392-4564 Email Address: mullenr@us.panasonic.com |

| MANUFACTURER | |
|------------------------|---|
| Name: | Matsushita Electric Industrial Co., Ltd. |
| Address: | 1 -15 Matsuo-cho Kadoma, Osaka Japan, 571-8504 |
| Contact Person: | Mr. Nobuyuki Nishihara Phone #: +81-6-6906-2739 Fax #: +81-6-6906-8405 Email Address: nishihara.nobuyuki@jp.panasonic.com |

3.2. EQUIPMENT UNDER TEST (EUT) INFORMATION

The following information (with the exception of the Date of Receipt) has been supplied by the applicant.

| | |
|---------------------------------------|--|
| Brand Name; | Panasonic |
| Product Name: | Portable DVD/CD Player |
| Model Name or Number: | DVD-LS55 |
| Serial Number: | Pre-production |
| Type of Equipment: | FM non-broadcast transmitter |
| Input Power Supply Type: | DC 9 V (DC IN terminal) / DC 7.2 V (Battery) |
| Primary User Functions of EUT: | DVD Play Function |

3.3. EUT'S TECHNICAL SPECIFICATIONS

| TRANSMITTER | |
|--|--|
| Equipment Type: | Portable |
| Intended Operating Environment: | Residential Commercial, light industry & heavy industry |
| Power Supply Requirement: | DC 9 V (DC IN terminal) / DC 7.2 V (Battery) |
| RF Output Power Rating: | 47.62 dB μ V/m (Peak at 3 Metres) 46.70 dB μ V/m (Average at 3 Metres) |
| Operating Frequency Range: | 88.3 – 90.3 MHz |
| Channel Spacing: | 0.1 MHz |
| RF Output Impedance: | 75 Ohms |
| 99% Occupied Bandwidth: | 174.75 kHz (Stereo Mode) 145.09 kHz (Mono Mode) |
| Modulation Type: | FM |
| Oscillator Frequencies: | 7.6 MHz |
| Antenna Connector Type: | Integral |
| Antenna Description: | Manufacturer: Matsushita Electric Industrial Co., Ltd Type: Monopole Antenna Model: Built-in Frequency Range: 88.3 MHz – 90.3 MHz Gain: -56.05 dBi |

3.4. LIST OF EUT'S PORTS

| Port Number | EUT's Port Description | Number of Identical Ports | Connector Type | Cable Type (Shielded/Non-shielded) |
|--------------------|-------------------------------|----------------------------------|-----------------------|---|
| 1 | VIDEO | 1 | 1/8" Mini Phone Jack | Shielded |
| 2 | AUDIO/OPT OUT | 1 | 1/8" Mini Phone Jack | Shielded |
| 3 | DC IN | 1 | DC Plug-in Jack | Non-shielded |
| 4 | Headphone Jack | 2 | 1/8" Mini Phone Jack | Shielded |

3.5. ANCILLARY EQUIPMENT

The EUT was tested while connected to the following representative configuration of ancillary equipment necessary to exercise the ports during tests:

| Ancillary Equipment # 1 | |
|--------------------------|----------------|
| Description: | Headset |
| Brand: | Labtec |
| Model Name or Number: | N/A |
| Serial Number: | N/A |
| Connected to EUT's Port: | Headphone Jack |

3.6. GENERAL TEST SETUP

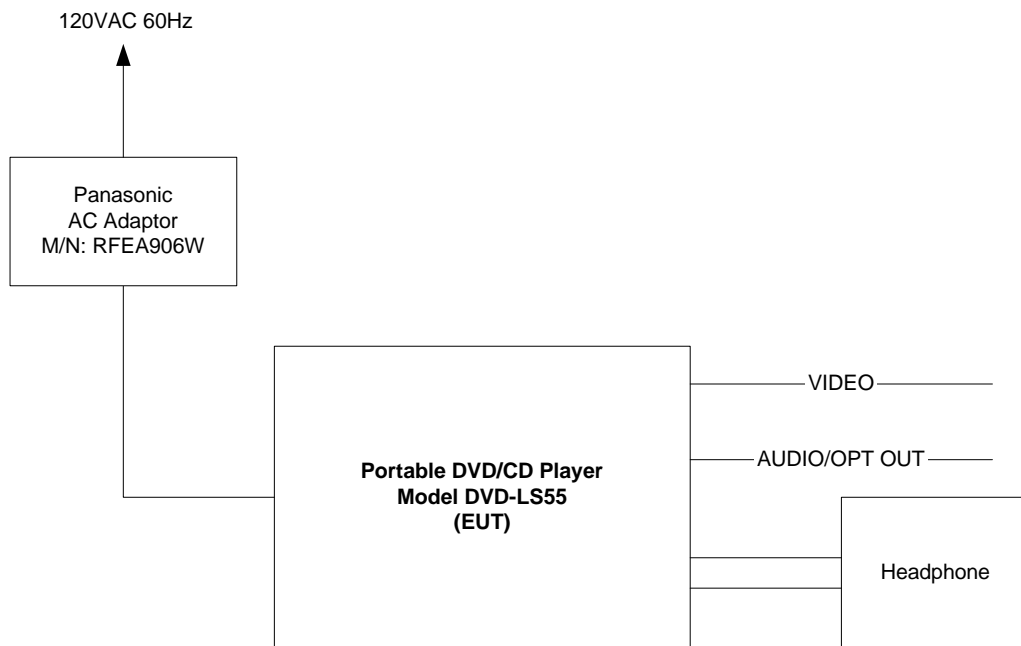

EXHIBIT 4. EUT OPERATING CONDITIONS AND CONFIGURATIONS DURING TESTS

4.1. CLIMATE TEST CONDITIONS

The climate conditions of the test environment are as follows:

| | |
|---------------------|--|
| Temperature: | 21°C |
| Humidity: | 51% |
| Pressure: | 102 kPa |
| Power Input Source: | DC 9 V (DC IN terminal) / DC 7.2 V (Battery) |

4.2. OPERATIONAL TEST CONDITIONS & ARRANGEMENT FOR TESTS

| | |
|----------------------------------|--|
| Operating Modes: | Each of the channel frequencies transmits continuously for emissions measurements. |
| Special Test Software: | None. |
| Special Hardware Used: | None. |
| Transmitter Test Antenna: | Integral antenna. |

| Transmitter Test Signals | |
|---|---|
| Frequency Band(s): | 88.3 – 90.3 MHz |
| Frequency(ies) Tested: | 88.3 MHz and 90.3 MHz |
| RF Power Output (measured maximum output power): | 47.62 dB μ V/m (Peak at 3 Metres) 46.70 dB μ V/m (Average at 3 Metres) |
| Normal Test Modulation: | FM |
| Modulating Signal Source: | Internal |

EXHIBIT 5. SUMMARY OF TEST RESULTS

5.1. LOCATION OF TESTS

All of the measurements described in this report were performed at Ultratech Group of Labs located in the city of Oakville, Province of Ontario, Canada.

- AC Power Line Conducted Emissions were performed in UltraTech's shielded room, 24'(L) by 16'(W) by 8'(H).
- Radiated Emissions were performed at the Ultratech's 3 Meter Open Field Test Site (OFTS) situated in the Town of Oakville, province of Ontario.

The above sites have been calibrated in accordance with ANSI C63.4, and found to be in compliance with the requirements of Sec. 2.948 of the FCC Rules. The descriptions and site measurement data of the Oakville Open Field Test Site has been filed with FCC office (FCC File No.: 31040/SIT 1300B3) and Industry Canada office (Industry Canada File No.: IC2049). Last Date of Site Calibration: February 17, 2004.

5.2. APPLICABILITY & SUMMARY OF EMC EMISSION TEST RESULTS

| FCC Section(s) | Test Requirements | Compliance (Yes/No) |
|--------------------|--|---------------------|
| 15.107(a) & 15.207 | AC Power Conducted Emissions | Yes |
| 15.239(a) | Occupied Bandwidth | Yes |
| 15.239(b) & (c) | Field Strength of Emissions Inside and Outside the permitted band 88 - 108 MHz | Yes |

The digital circuit portion of the EUT has been tested and verified to comply with FCC Part 15, Subpart B, Class B Digital Devices. The engineering test report can be provided upon requests.

5.3. MODIFICATIONS INCORPORATED IN THE EUT FOR COMPLIANCE PURPOSES

The following changes were made on the FMT PCB for compliance:

- 1) Adding chip resistors:
 - i) Circuit No.: R4909
Rating : 33 Ohms 1/10W
 - ii) Circuit No.: R4910, R4911
Rating : 330 Ohms 1/10W
- 2) Adding copper foils to the FPC:

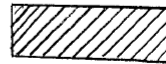
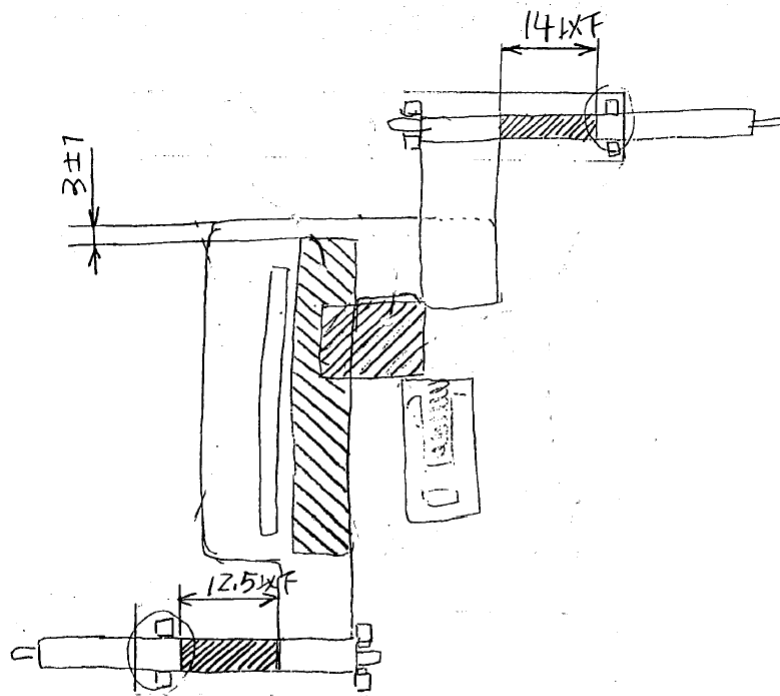

Position of
copper foil

EXHIBIT 6. MEASUREMENTS, EXAMINATIONS & TEST DATA FOR EMC EMISSIONS

6.1. TEST PROCEDURES

This section contains test results only. Details of test methods and procedures can be found in Exhibit 8 of this report.

6.2. MEASUREMENT UNCERTAINTIES

The measurement uncertainties stated were calculated in accordance with requirements of UKAS Document NIS 81 with a confidence level of 95%. Please refer to Exhibit 7 for Measurement Uncertainties.

6.3. MEASUREMENT EQUIPMENT USED

The measurement equipment used complied with the requirements of the Standards referenced in the Methods & Procedures ANSI C64-3, FCC 15.239 and CISPR 16-1.

6.4. ESSENTIAL/PRIMARY FUNCTIONS AS DECLARED BY THE MANUFACTURER

The essential function of the EUT is to correctly communicate data to radios over RF link.

6.5. AC POWER LINE CONDUCTED EMISSIONS [§ 15.207]

6.5.1. Limits

The equipment shall meet the limits of the following table:

| Frequency of emission (MHz) | Conducted limit (dB μ V) | |
|--------------------------------|------------------------------|-----------|
| | Quasi-peak | Average |
| 0.15–0.5 | 66 to 56* | 56 to 46* |
| 0.5–5 | 56 | 46 |
| 5–30 | 60 | 50 |

*Decreases with the logarithm of the frequency.

6.5.2. Method of Measurements

Refer to Section 8.2 of this test report & ANSI C63.4 for details.

6.5.3. Test Equipment List

| Test Instruments | Manufacturer | Model No. | Serial No. | Frequency Range |
|------------------------------------|-----------------|-----------|------------|---|
| Spectrum Analyzer/ EMI Receiver | Hewlett Packard | HP 85462A | 3325A00141 | 9 kHz – 6.5 GHz |
| Transient Limiter | Hewlett Packard | 11947A | 310701998 | 9 kHz – 200 MHz 10 dB attenuation |
| L.I.S.N. | EMCO | 3825/2 | 89071531 | 9 kHz – 200 MHz 50 Ohms / 50 μ H |
| 24'x16'x8' RF Shielded Chamber | RF Shielding | ... | .. | ... |

6.5.4. Test Data

| Frequency (MHz) | RF Level (dBuV) | Receiver Detector (QP/AVG) | QP Limit (dBuV) | AVG Limit (dBuV) | Margin (dB) | Pass/Fail | Line Tested (L1/L2) |
|--|-----------------|----------------------------|-----------------|------------------|-------------|-----------|---------------------|
| FM Transmitter ON (Stereo Mode) | | | | | | | |
| 1.011475 | 41.0 | QP | 56.0 | 46.0 | -15.0 | Pass | L1 |
| 1.011475 | 38.4 | AVG | 56.0 | 46.0 | -7.6 | Pass | L1 |
| 8.160000 | 34.4 | QP | 60.0 | 50.0 | -25.6 | Pass | L1 |
| 8.160000 | 25.6 | AVG | 60.0 | 50.0 | -24.4 | Pass | L1 |
| FM Transmitter OFF | | | | | | | |
| 0.210335 | 40.9 | QP | 63.2 | 53.2 | -22.3 | Pass | L2 |
| 0.210335 | 36.6 | AVG | 63.2 | 53.2 | -16.6 | Pass | L2 |
| 2.194975 | 41.5 | QP | 56.0 | 46.0 | -14.5 | Pass | L2 |
| 2.194975 | 28.3 | AVG | 56.0 | 46.0 | -17.7 | Pass | L2 |
| 8.285000 | 43.6 | QP | 60.0 | 50.0 | -16.4 | Pass | L2 |
| 8.285000 | 30.7 | AVG | 60.0 | 50.0 | -19.3 | Pass | L2 |
| FM Transmitter OFF | | | | | | | |
| 2.192750 | 38.6 | QP | 56.0 | 46.0 | -17.4 | Pass | L1 |
| 2.192750 | 27.7 | AVG | 56.0 | 46.0 | -18.3 | Pass | L1 |
| 8.248350 | 38.9 | QP | 60.0 | 50.0 | -21.1 | Pass | L1 |
| 8.248350 | 30.6 | AVG | 60.0 | 50.0 | -19.4 | Pass | L1 |
| FM Transmitter OFF | | | | | | | |
| 0.209633 | 41.4 | QP | 63.2 | 53.2 | -21.8 | Pass | L2 |
| 0.209633 | 37.2 | AVG | 63.2 | 53.2 | -16.0 | Pass | L2 |
| 2.196250 | 44.0 | QP | 56.0 | 46.0 | -12.0 | Pass | L2 |
| 2.196250 | 33.0 | AVG | 56.0 | 46.0 | -13.0 | Pass | L2 |
| 8.154919 | 44.4 | QP | 60.0 | 50.0 | -15.6 | Pass | L2 |
| 8.154919 | 37.1 | AVG | 60.0 | 50.0 | -12.9 | Pass | L2 |

See the following plots (1 to 4) for detailed measurements.

Plot 1:
AC Power Line Conducted Emissions (FM Transmitter ON, Stereo Mode)
Line Voltage: 120VAC 60Hz
Line Tested: Line 1



ULTRATECH LABS 09:24:24 JAN 08, 2004

| Signal | Freq (MHz) | PK Amp | QP Amp | AV Amp | AV Δ L2 |
|--------|------------|--------|--------|--------|----------------|
| 1 | 1.011475 | 47.7 | 41.0 | 38.4 | -7.6 |
| 2 | 8.160000 | 37.0 | 34.4 | 25.6 | -24.4 |

ACTV DET: PEAK
 MEAS DET: PEAK QP AVG
 MKR 1.00 MHz
 40.44 dB μ V

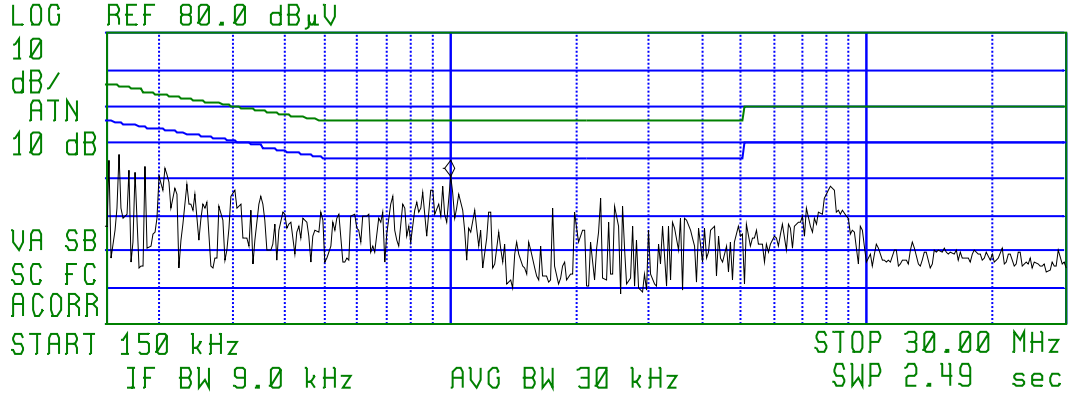

Plot 2:
AC Power Line Conducted Emissions (FM Transmitter ON, Stereo Mode)
Line Voltage: 120VAC 60Hz
Line Tested: Line 2



ULTRATECH LABS 09:24:24 JAN 08, 2004

| Signal | Freq (MHz) | PK Amp | QP Amp | AV Amp | AV Δ L2 |
|--------|------------|--------|--------|--------|----------------|
| 1 | 0.210335 | 45.5 | 40.9 | 36.6 | -16.6 |
| 2 | 2.194975 | 45.1 | 41.5 | 28.3 | -17.7 |
| 3 | 8.285000 | 45.2 | 43.6 | 30.7 | -19.3 |

ACTV DET: PEAK
 MEAS DET: PEAK QP AVG
 MKR 8.31 MHz
 41.68 dB μ V

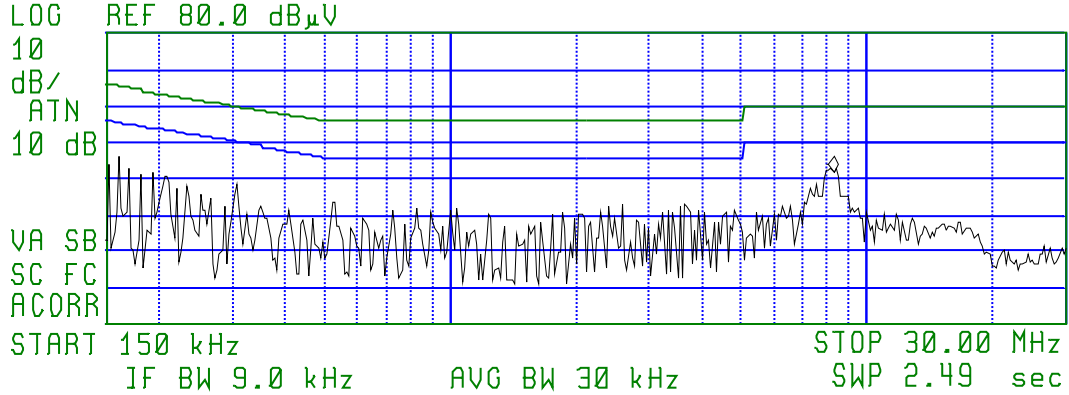

Plot 3:
AC Power Line Conducted Emissions (FM Transmitter OFF)
Line Voltage: 120VAC 60Hz
Line Tested: Line 1



ULTRATECH LABS 09:24:24 JAN 08, 2004

| Signal | Freq (MHz) | PK Amp | QP Amp | AV Amp | AV Δ L2 |
|--------|------------|--------|--------|--------|----------------|
| 1 | 2.192750 | 41.7 | 38.6 | 27.7 | -18.3 |
| 2 | 8.248350 | 40.7 | 38.9 | 30.6 | -19.4 |

ACTV DET: PEAK
MEAS DET: PEAK QP AVG
MKR 8.18 MHz
39.60 dB μ V

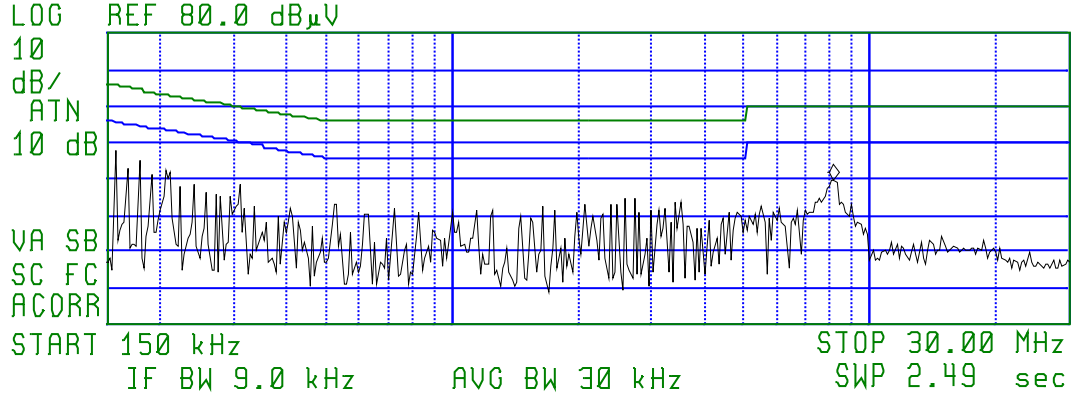

Plot 4:
AC Power Line Conducted Emissions (FM Transmitter OFF)
Line Voltage: 120VAC 60Hz
Line Tested: Line 2



ULTRATECH LABS 09:24:24 JAN 08, 2004

| Signal | Freq (MHz) | PK Amp | QP Amp | AV Amp | AV Δ L2 |
|--------|------------|--------|--------|--------|----------------|
| 1 | 0.209633 | 46.5 | 41.4 | 37.2 | -16.1 |
| 2 | 2.196250 | 47.2 | 44.0 | 33.0 | -13.1 |
| 3 | 8.154919 | 46.5 | 44.4 | 37.1 | -12.9 |

ACTV DET: PEAK
 MEAS DET: PEAK QP AVG
 MKR 8.18 MHz
 45.44 dB μ V

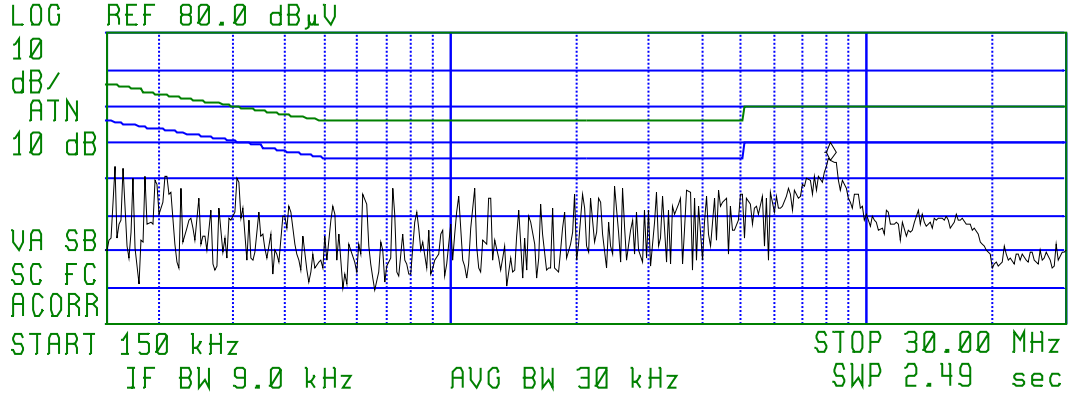

6.6. OCCUPIED BANDWIDTH [§ 15.239(a)]

6.6.1. Limits

Emissions from the intentional radiator shall be confined within a band 200 kHz wide centered on the operating frequency. The 200 kHz band shall lie wholly within the frequency range of 88–108 MHz.

6.6.2. Method of Measurements

The 99% bandwidth was measured using the 99% automatic function of the spectrum analyzer.

6.6.3. Test Equipment List

| Test Instruments | Manufacturer | Model No. | Serial No. | Frequency Range |
|-------------------|-----------------|---------------|------------|-----------------|
| Spectrum Analyzer | Rohde & Schwarz | FSEK20/B4/B21 | 834157/005 | 9 kHz – 40 GHz |
| Dipole Antenna | EMCO | 3121C-DB2 | 440 | 30 MHz – 1 GHz |

6.6.4. Test Arrangement

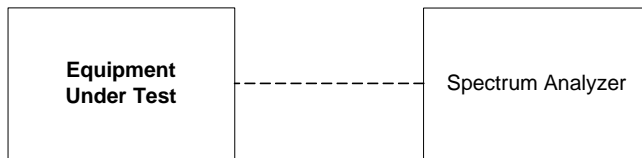

6.6.5. Test Data

| Channel Frequency (MHz) | 99% Occupied Bandwidth (kHz) |
|-------------------------|------------------------------|
| Stereo Mode | |
| 88.3 | 174.75 |
| 90.3 | 168.34 |
| Mono Mode | |
| 88.3 | 137.88 |
| 90.3 | 145.09 |

See the following plots (5 – 8) for detailed measurements.

Plot 5:
99% Occupied Bandwidth
Test Frequency: 88.3 MHz (Stereo Mode)

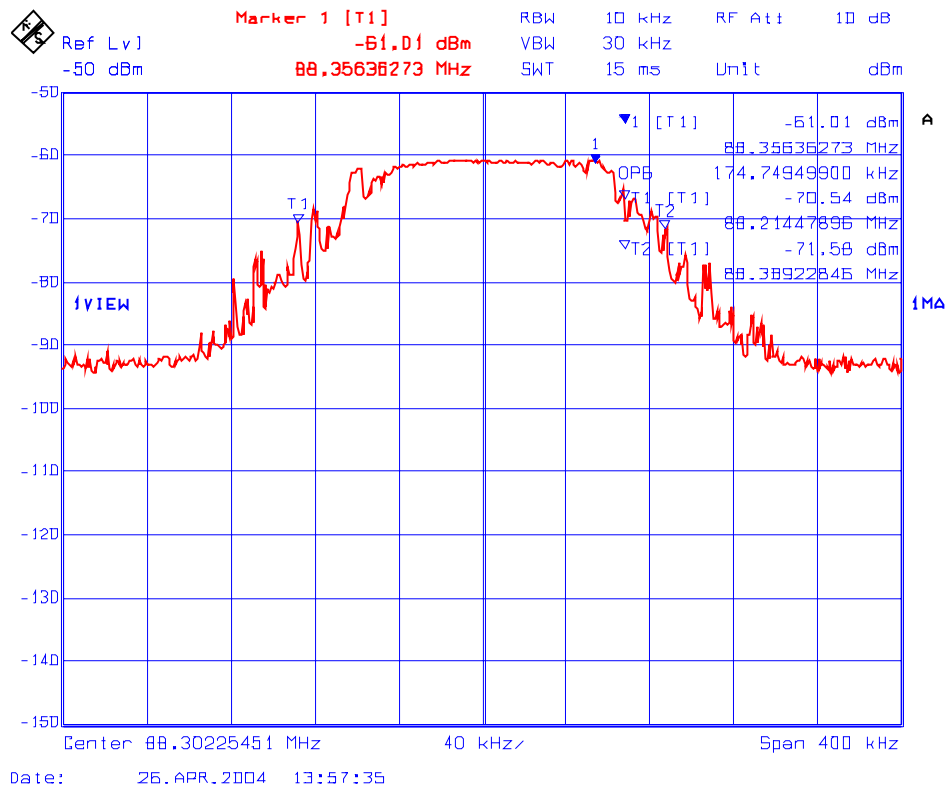

Plot 6:
99% Occupied Bandwidth
Test Frequency: 90.3 MHz (Stereo Mode)

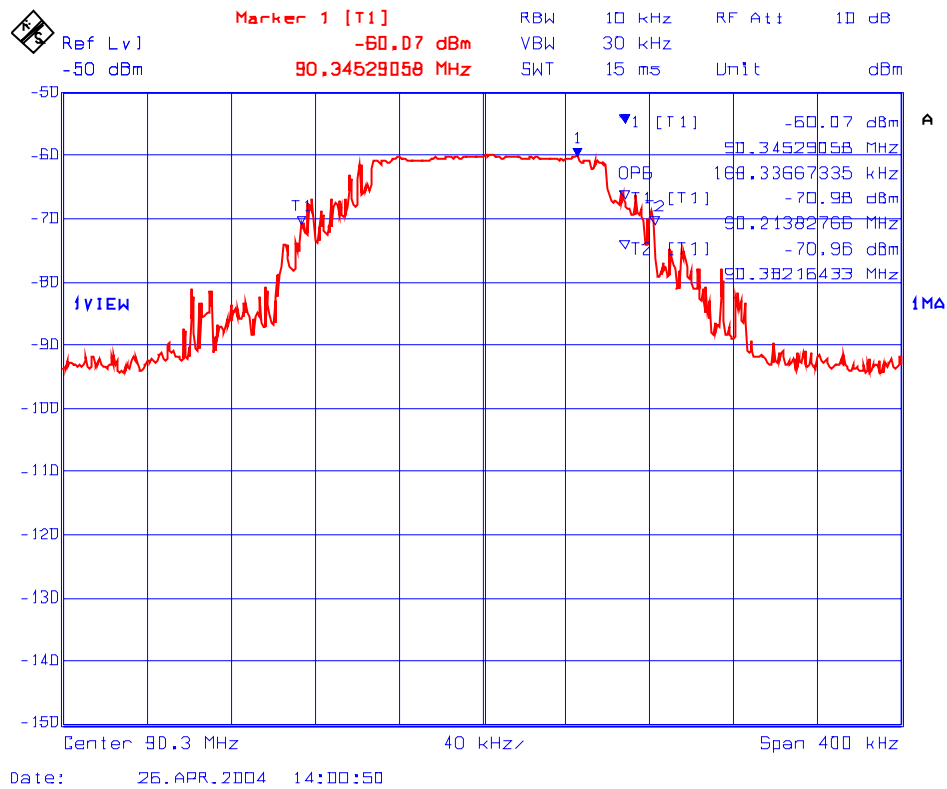

**Plot 7:
 99% Occupied Bandwidth
 Test Frequency: 88.3 MHz (Mono Mode)**

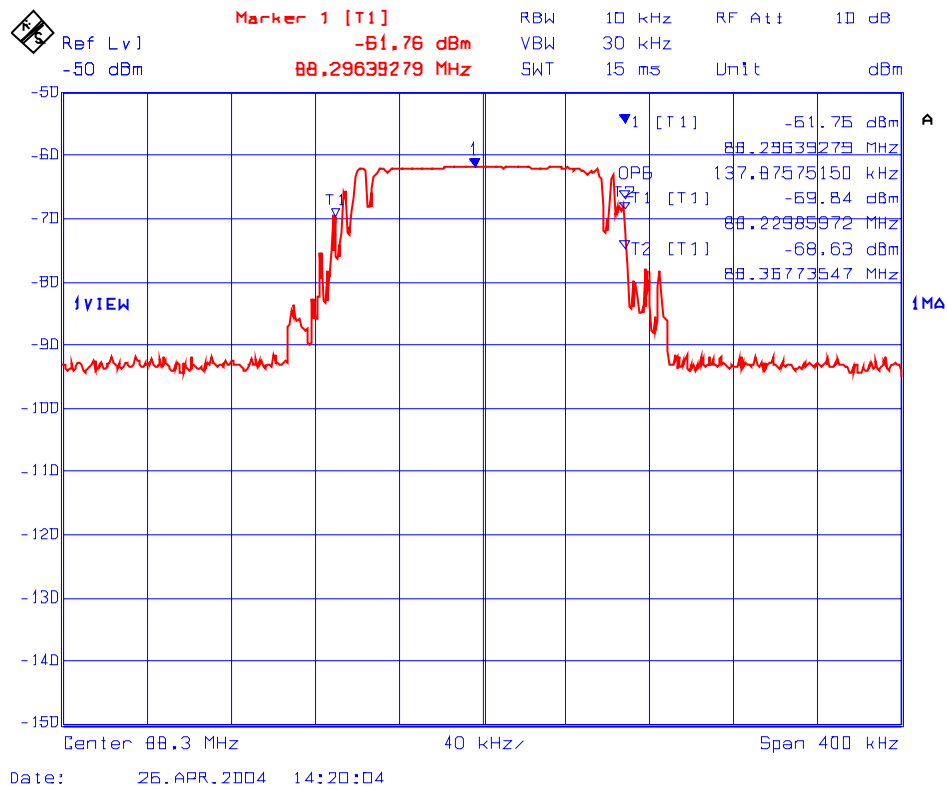

Plot 8:
99% Occupied Bandwidth
Test Frequency: 90.3 MHz (Mono Mode)

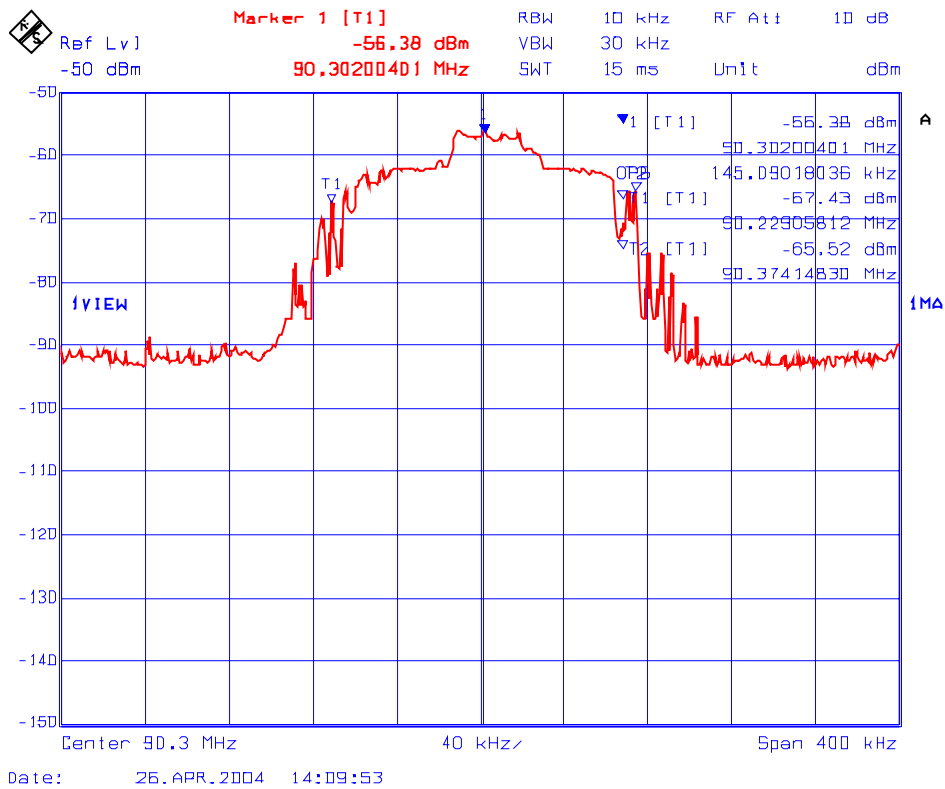

6.7. FIELD STRENGTH OF EMISSIONS INSIDE & OUTSIDE THE PERMITTED BAND 88-108 MHz [§ 15.239(b)&(c)]

6.7.1. Limits

§15.239:

- (b) The field strength of any emissions within the permitted 200 kHz band shall not exceed 250 microvolts/meter at 3 meters. The emission limit in this paragraph is based on measurement instrumentation employing an average detector. The provisions in § 15.35 for limiting peak emissions apply.
- (c) The field strength of any emissions radiated on any frequency outside of the specified 200 kHz band shall not exceed the general radiated emission limits in § 15.209.

47 CFR 15.209(a) General Radiated Emission Limits

| Frequency (MHz) | Field strength (microvolts/meter) | Measurement distance (meters) |
|--|-----------------------------------|-------------------------------|
| 0.009–0.490 | 2400/F(kHz) | 300 |
| 0.490–1.705 | 24000/F(kHz) | 30 |
| 1.705–30.0 | 30 | 30 |
| 30–88 | 100 ** | 3 |
| 88–216 | 150 ** | 3 |
| 216–960 | 200 ** | 3 |
| Above 960 | 500 | 3 |
| ** Except as provided in paragraph (g), fundamental emissions from intentional radiators operating under this section shall not be located in the frequency bands 54–72 MHz, 76– 88 MHz, 174–216 MHz or 470–806 MHz. However, operation within these frequency bands is permitted under other sections of this part, e.g., §§ 15.231 and 15.241. | | |

6.7.2. Method of Measurements

Refer to Section 8.3 of this test report and ANSI 63.4-2003 for detailed radiated emissions measurement procedures.

The following measurement procedures were also applied:

- Applies to harmonics/spurious that fall in the restricted bands listed in Section 15.205. The maximum permitted average field strength is listed in Section 15.209. A Pre-Amp and highpass filter are used for this measurement.
- For 9 kHz ≤ frequencies ≤ 150 kHz: RBW = 1 KHz, VBW ≥ 1 KHz, SWEEP=AUTO.
- For 150 MHz ≤ frequencies ≤ 30 MHz: RBW = 10 KHz, VBW ≥ 10 KHz, SWEEP=AUTO.
- For 30 MHz ≤ frequencies ≤ 1 GHz: RBW = 100 KHz, VBW ≥ 100 KHz, SWEEP=AUTO.
- For frequencies ≥ 1 GHz: RBW = 1 MHz, VBW = 1 MHz (Peak) & VBW = 10 Hz (Average), SWEEP=AUTO.
- If the emission is pulsed, modified the unit for continuous operation, then use the settings above for measurements, then correct the reading by subtracting the peak-average correction factor derived from the appropriate duty cycle calculation. See Section 15.35(b) and (c).

6.7.3. Test Equipment List

| Test Instruments | Manufacturer | Model No. | Serial No. | Frequency Range |
|---|-----------------|---------------|--------------------------|-----------------------------|
| Spectrum Analyzer/ EMI Receiver | Hewlett Packard | HP 8593EM | 3412A00103 | 9 kHz – 26.5 GHz |
| Peak Power Meter & Peak Power Sensor | Hewlett Packard | 8900 8481A | 2131A00124 2551A01965 | 0.1-18 GHz 50 Ohms Input |
| Microwave Amplifier | Hewlett Packard | HP 83017A | | 1 GHz to 26.5 GHz |
| Active Loop Antenna | EMCO | 6507 | 8906-1167 | 1 kHz – 30 MHz |
| Log Periodic / Bow-Tie Antenna | EMCO | 3143 | 1029 | 20 - 1000 MHz |

6.7.4. Test Data

6.7.4.1. Field Strength Within the Permitted Band [Stereo Mode]

| Frequency (MHz) | RF Level @ 3m (dBµV/m) | Detector Used (Peak/AVG) | Antenna Plane (H/V) | Limits (dBµV/m) | Margin (dB) | Pass/Fail |
|--------------------------------------|------------------------|--------------------------|---------------------|-----------------|-------------|-----------|
| Carrier Frequency at 88.3 MHz | | | | | | |
| 88.3 | 45.11 | Peak | V | 48.0 | -2.9 | Pass |
| 88.3 | 47.62 | Peak | H | 48.0 | -0.4 | Pass |
| 88.3 | 44.72 | AVG | V | 48.0 | -3.3 | Pass |
| 88.3 | 46.70 | AVG | H | 48.0 | -1.3 | Pass |
| Carrier Frequency at 99.3 MHz | | | | | | |
| 99.3 | 43.21 | Peak | V | 48.0 | -4.8 | Pass |
| 99.3 | 46.02 | Peak | H | 48.0 | -2.0 | Pass |
| 99.3 | 42.70 | AVG | V | 48.0 | -5.3 | Pass |
| 99.3 | 45.96 | AVG | H | 48.0 | -2.0 | Pass |

6.7.4.2. Field Strength Outside the Permitted Band (as well as outside the band 88 –108MHz)[Stereo Mode]

The EUT was set to transmit at 88.3 MHz (Test Mode 1) and 90.3 MHz (Test Mode 2). Emissions were scanned from 30 MHz to 1000MHz for Test Mode 1 and Test Mode 2; all emissions outside of the permitted band were more than 20dB below the permissible limit.

EXHIBIT 7. MEASUREMENT UNCERTAINTY

The measurement uncertainties stated were calculated in accordance with the requirements of NIST Technical Note 1297 and NIS 81 (1994)

7.1. LINE CONDUCTED EMISSION MEASUREMENT UNCERTAINTY

| CONTRIBUTION (Line Conducted) | PROBABILITY DISTRIBUTION | UNCERTAINTY (dB) | |
|---|-----------------------------|------------------|-------------|
| | | 9-150 kHz | 0.15-30 MHz |
| EMI Receiver specification | Rectangular | ±1.5 | ±1.5 |
| LISN coupling specification | Rectangular | ±1.5 | ±1.5 |
| Cable and Input Transient Limiter calibration | Normal (k=2) | ±0.3 | ±0.5 |
| Mismatch: Receiver VRC $\Gamma_1 = 0.03$ LISN VRC $\Gamma_R = 0.8(9 \text{ kHz}) 0.2 (30 \text{ MHz})$ Uncertainty limits $20\text{Log}(1 \pm \Gamma_1 \Gamma_R)$ | U-Shaped | ±0.2 | ±0.3 |
| System repeatability | Std. deviation | ±0.2 | ±0.05 |
| Repeatability of EUT | -- | -- | -- |
| Combined standard uncertainty | Normal | ±1.25 | ±1.30 |
| Expanded uncertainty U | Normal (k = 2) | ±2.50 | ±2.60 |

Sample Calculation for Measurement Accuracy in 450 kHz to 30 MHz Band:

$$u_c(y) = \sqrt{\sum_{i=1}^m u_i^2(y)} = \pm \sqrt{(1.5^2 + 1.5^2)/3 + (0.5/2)^2 + (0.05/2)^2 + 0.35^2} = \pm 1.30 \text{ dB}$$

$$U = 2u_c(y) = \pm 2.6 \text{ dB}$$

7.2. RADIATED EMISSION MEASUREMENT UNCERTAINTY

| CONTRIBUTION (Radiated Emissions) | PROBABILITY DISTRIBUTION | UNCERTAINTY (+ dB) | |
|---|-----------------------------|--------------------|---------------|
| | | 3 m | 10 m |
| Antenna Factor Calibration | Normal (k=2) | ± 1.0 | ± 1.0 |
| Cable Loss Calibration | Normal (k=2) | ± 0.3 | ± 0.5 |
| EMI Receiver specification | Rectangular | ± 1.5 | ± 1.5 |
| Antenna Directivity | Rectangular | +0.5 | +0.5 |
| Antenna factor variation with height | Rectangular | ± 2.0 | ± 0.5 |
| Antenna phase center variation | Rectangular | 0.0 | ± 0.2 |
| Antenna factor frequency interpolation | Rectangular | ± 0.25 | ± 0.25 |
| Measurement distance variation | Rectangular | ± 0.6 | ± 0.4 |
| Site imperfections | Rectangular | ± 2.0 | ± 2.0 |
| Mismatch: Receiver VRC $\Gamma_1 = 0.2$ Antenna VRC $\Gamma_R = 0.67(\text{Bi}) 0.3 (\text{Lp})$ Uncertainty limits $20\text{Log}(1 \pm \Gamma_1 \Gamma_R)$ | U-Shaped | +1.1 -1.25 | ± 0.5 |
| System repeatability | Std. Deviation | ± 0.5 | ± 0.5 |
| Repeatability of EUT | | - | - |
| Combined standard uncertainty | Normal | +2.19 / -2.21 | +1.74 / -1.72 |
| Expanded uncertainty U | Normal (k = 2) | +4.38 / -4.42 | +3.48 / -3.44 |

Calculation for maximum uncertainty when 3m biconical antenna including a factor of k = 2 is used:

$$U = 2u_c(y) = 2x(+2.19) = +4.38 \text{ dB} \quad \text{And} \quad U = 2u_c(y) = 2x(-2.21) = -4.42 \text{ dB}$$

EXHIBIT 8. GENERAL TEST PROCEDURES

8.1. GENERAL TEST CONDITIONS

The following test conditions shall be applied throughout the tests covered in this report.

8.1.1. Normal Temperature and Humidity

Normal temperature: +15°C to +35°C

Relative Humidity: +20% to 75%

The actual values during tests shall be recorded in the test report.

8.1.2. Normal power source

8.1.2.1. Mains Voltage

The nominal test voltage of the equipment to be connected to mains shall be the nominal mains voltage which is the declared voltage or any of the declared voltages for which the equipment was designed.

The frequency of test power source corresponding to the AC mains shall be between 59 Hz and 61 Hz.

8.1.2.2. Battery Power Source

For operation from battery power sources, the nominal test voltage shall be as declared by the equipment manufacturer. This shall be recorded in the test report.

8.1.3. Operating Condition of Equipment Under Test

- All tests shall be performed with the device operating at the number of frequencies in each band specified in the following table:

| Frequency range over which device operates | Number of frequencies | Location in the range of operation |
|--|-----------------------|--|
| 1 MHz or less | 1 | Middle. |
| 1 to 10 MHz | 2 | 1 near top and 1 near bottom. |
| More than 10 MHz | 3 | 1 near top, 1 near middle and 1 near bottom. |

- Modulation were applied using the Test Data sequence
- The transmitter was operated at the highest output power, or in the case the equipment able to operate at more than one power level, at the lowest and highest output powers.

8.2. METHOD OF MEASUREMENTS - AC MAINS CONDUCTED EMISSIONS

- AC Mains conducted emissions measurements were performed in accordance with the standard against appropriate limits for each detector function.
- The test was performed in the shielded room, 24'(L) x 16'(W) x 8'(H).
- The test was performed were made over the frequency range from 150 kHz to 30 MHz to determine the line-to-ground radio noise voltage which was conducted from the EUT power-input terminals that were directly connected to a public power network.
- The EUT normally received power from another device that connects to the public utility ac power lines, measurements would be made on that device with the EUT in operation to ensure that the device continues to comply with the appropriate limits while providing the EUT with power.
- If the EUT operates only from internal or dedicated batteries, with no provisions for connection to the public utility ac power lines, AC Mains conducted measurements are not required.
- Table-top devices were placed on a platform of nominal size 1 m by 1.5m raised 80 cm above the conducting ground plane.
- The EUT current-carrying power lead, except the ground (safety) lead, was individually connected through a LISN to the power source. All unused 50-Ohm connectors of the LISN was terminated in 50-ohm when not connected to the measuring instruments.
- The line cord of the EUT connected to one LISN which was connected to the measuring instrument. Those power cords for the units of devices not under measurement were connected to a separate multiple ac outlet. Drawings and photographs of typically conducted emission test setups were shown in the Test Report. Each current-carrying conductor of the EUT shall be individually tested.
- The EUT was normally operated with a ground (safety) connection, the EUT was connected to the ground at the LISN through a conductor provided in the lead from the ac power mains to the LISN.
- The excess length of the power cord was folded back and forth in an 8-shape on a wooden strip with a vertical prong located on the top of the LISN case.
- The EUT was set-up in its typical configuration and operated in its various modes as described in 3.2 of the test report.
- A preliminary scan was made by using spectrum analyzer system with the detector function set to PEAK mode (9 KHz RBW, VBW > RBW), frequency span 150 kHz to 30 MHz.
- The maximum conducted emission for a given mode of operation was found by using the following step-by-step procedure:
 - Step 1: Monitor the frequency range of interest at a fixed EUT azimuth.
 - Step 2: Manipulate the system cables and peripheral devices to produce highest amplitude signal relative to the limit. Note the amplitude and frequency of the suspect signal.
 - Step 3: The effects of various modes of operation is examined. This is done by varying equipment operation modes as step 2 is being performed.
 - Step 4: After completing step 1 through 3, record EUT and peripheral device configuration, mode of operation, cable configuration, signal levels and frequencies for final test.
- Each highest signal level at the maximized test configuration was zoomed in a small frequency span on the spectrum analyzer's display (the manipulation of cables and peripheral devices and EUT operation modes might have to be repeated to obtain the highest signal level with the spectrum analyzer set to PEAK detector mode 10 KHz RBW and VBW > RBW). The spectrum analyzer was then set to CISPR QUASI-PEAK detector mode (9 KHz RBW, 1 MHz VBW) and AVERAGE detector mode (10 kHz RBW, 1 Hz VBW). The final highest RF signal levels and frequencies were record.

8.3. SPURIOUS EMISSIONS (CONDUCTED & RADIATED)

For both conducted and radiated measurements, the spurious emissions were scanned from the lowest frequency generated by the EUT or 10 MHz whichever is lower to 10th harmonic of the highest frequency generated by the EUT.

8.3.1. Spurious Emissions (Conducted)

- The radio was connected to the measuring equipment via a suitable attenuator.
- The spectrum analyzer were used and set as follows:
 - Resolution BW: 100 kHz
 - Video BW: same or greater
 - Detector Mode: Positive Peak
 - Averaging: Off
 - Span: 100 MHz
 - Amplitude: Adjust for middle of the instrument's range
 - Sweep Time: Auto

8.3.2. Spurious Emissions (Radiated)

- The radiated emission measurements were performed at the UltraTech's 3 Meter Open Field Test Site (OFTS) situated in the Town of Oakville, province of Ontario. The Attenuation Characteristics of OFTS have been filed to FCC, Industry Canada, ACA/Austel, NVLap and ITI.
- Radiated emissions measurements were made using the following test instruments:

Calibrated EMCO BiconiLog antenna in the frequency range from 30 MHz to 2000 MHz.

Calibrated Emco Horn antennas in the frequency range above 1000 MHz (1GHz - 40 GHz).

Calibrated Advantest spectrum analyzer and pre-selector were used. The spectrum analyzer would be used as follows:

For frequencies below 1 GHz:

- Resolution BW: 100 kHz
- Video BW: same or greater
- Detector Mode: Positive Peak
- Averaging: Off
- Span: 100 MHz
- Amplitude: Adjust for middle of the instrument's range
- Sweep Time: Auto

For frequencies above 1 GHz:

- Resolution BW: 1 MHz
- Video BW: same or greater
- Detector Mode: Positive Peak
- Averaging: Off
- Span: 500 MHz
- Amplitude: Adjust for middle of the instrument's range
- Sweep Time: Auto

- The frequencies of emissions were first detected. Then the amplitude of the emissions was measured at the specified measurement distance using required antenna height, polarization, and detector characteristics.
- During this process, cables and peripheral devices were manipulated within the range of likely configuration.
- For each mode of operation required to be tested, the frequency spectrum was monitored. Variations in antenna heights (from 1 meter to 4 meters above the ground plane), antenna polarization (horizontal plane and vertical plane), cable placement and peripheral placement were explored to produce the highest amplitude signal relative to the limit.
- The maximum radiated emission for a given mode of operation was found by using the following step-by-step procedure:
 - Monitor the frequency range of interest at a fixed antenna height and EUT azimuth.
 - Manipulate the system cables to produce highest amplitude signal relative to the limit. Note the amplitude and frequency of the suspect signal.
 - Rotate the EUT 360 degrees to maximize the suspected highest amplitude signal. If the signal or another at a different frequency is observed to exceed the previously noted highest amplitude signal by 1 dB or more, go back to the azimuth and repeat Step 2. Otherwise, orient the EUT azimuth to repeat the highest amplitude observation and proceed.
- Move the antenna over its full allowable range of travel (1 to 4 meters) to maximize the suspected highest amplitude signal. If the signal or another at a different frequency is observed to exceed the previously noted highest amplitude signal by 1 dB or more, return to Step 2 with the highest amplitude observation and proceed.
- Change the polarization of the antenna and repeat Step 2 through 4. Compare the resulting suspected highest amplitude signal with that found for the other polarization. Select and note the higher of the two signals. This signal is termed the highest observed signal with respect to the limit for this EUT operational mode.
- The effects of various modes of operation is examined. This is done by varying the equipment modes as steps 2 through 5 are being performed.
- After completing steps 1 through 6, record the final highest emission level, frequency, antenna polarization and detector mode of the measuring instrument.

Calculation of Field Strength:

The field strength is calculated by adding the calibrated antenna factor and cable factor, and subtracting the Amplifier gain (if any) from the measured reading. The basic equation with a sample calculation is as follows:

$$FS = RA + AF + CF - AG$$

Where FS = Field Strength
RA = Receiver/Analyzer Reading
AF = Antenna Factor
CF = Cable Attenuation Factor
AG = Amplifier Gain

Example: If a receiver reading of 60.0 dBμV is obtained, the antenna factor of 7.0 dB/m and cable factor of 1.0 dB are added, and the amplifier gain of 30 dB is subtracted. The actual field strength will be:

Field Level = 60 + 7.0 + 1.0 - 30 = 38.0 dBμV/m.
Field Level = 10^(38/20) = 79.43 μV/m.