



SAR EVALUATION REPORT

Applicant Name:
 Panasonic Corporation of North America
 One Panasonic Way, 4B-8
 Secaucus, NJ 07094
 United States

Date of Testing:
 12/15/2014 - 01/08/2015
Test Site/Location:
 PCTEST Lab, Columbia, MD, USA
Document Serial No.:
 0Y1412152300.ACJ

FCC ID: ACJ9TGWW13B

APPLICANT: PANASONIC CORPORATION OF NORTH AMERICA

DUT Type: Wireless Module
Application Type: Class II Permissive Change
FCC Rule Part(s): CFR §2.1093
Model(s): WW13B
Permissive Change(s): The wireless module FCC ID: ACJ9TGWW13B is integrated into the host tablet Toughpad Model FZ-R1

Equipment Class	Band & Mode	Tx Frequency	SAR
			1 gm Body (W/kg)
PCB	GPRS/EDGE 850	824.20 - 848.80 MHz	0.97
PCB	GPRS/EDGE 1900	1850.20 - 1909.80 MHz	0.79
PCB	UMTS 850	826.40 - 846.60 MHz	0.49
PCB	UMTS 1750	1712.4 - 1752.5 MHz	0.77
PCB	UMTS 1900	1852.4 - 1907.6 MHz	1.13
PCB	CDMA/EVDO BC10 (§90S)	817.90 - 823.10 MHz	0.63
PCB	CDMA/EVDO BC0 (§22H)	824.70 - 848.31 MHz	0.70
PCB	PCS CDMA/EVDO	1851.25 - 1908.75 MHz	1.03
PCB	LTE Band 17	706.5 - 713.5 MHz	0.40
PCB	LTE Band 13	779.5 - 784.5 MHz	0.49
PCB	LTE Band 5 (Cell)	824.7 - 848.3 MHz	0.51
PCB	LTE Band 4 (AWS)	1710.7 - 1754.3 MHz	0.99
PCB	LTE Band 25 (PCS)	1850.7 - 1914.3 MHz	1.01
Simultaneous SAR per KDB 690783 D01v01r03:			1.58



This wireless portable device has been shown to be capable of compliance for localized specific absorption rate (SAR) for uncontrolled environment/general population exposure limits specified in ANSI/IEEE C95.1-1992 and has been tested in accordance with the measurement procedures specified in Section 1.8 of this report; for North American frequency bands only.

I attest to the accuracy of data. All measurements reported herein were performed by me or were made under my supervision and are correct to the best of my knowledge and belief. I assume full responsibility for the completeness of these measurements and vouch for the qualifications of all persons taking them. Test results reported herein relate only to the item(s) tested.

 Randy Ortanez
 President





The SAR Tick is an initiative of the Mobile Manufacturers Forum (MMF). While a product may be considered eligible, use of the SAR Tick logo requires an agreement with the MMF. Further details can be obtained by emailing: sartick@mmfai.info.

FCC ID: ACJ9TGWW13B		SAR EVALUATION REPORT		Reviewed by: Quality Manager
Document S/N: 0Y1412152300.ACJ	Test Dates: 12/15/14 - 01/08/15	DUT Type: Wireless Module	Page 1 of 91	

T A B L E O F C O N T E N T S

1	DEVICE UNDER TEST	3
2	LTE INFORMATION	9
3	INTRODUCTION	10
4	DOSIMETRIC ASSESSMENT	11
5	SAR TESTING PROCEDURES	12
6	RF EXPOSURE LIMITS	13
7	FCC MEASUREMENT PROCEDURES.....	14
8	RF CONDUCTED POWERS.....	18
9	SYSTEM VERIFICATION.....	59
10	SAR DATA SUMMARY	61
11	FCC MULTI-TX AND ANTENNA SAR CONSIDERATIONS.....	70
12	SAR MEASUREMENT VARIABILITY	86
13	EQUIPMENT LIST.....	87
14	MEASUREMENT UNCERTAINTIES	88
15	CONCLUSION.....	89
16	REFERENCES	90
APPENDIX A: SAR TEST PLOTS		
APPENDIX B: SAR DIPOLE VERIFICATION PLOTS		
APPENDIX C: PROBE AND DIPOLE CALIBRATION CERTIFICATES		
APPENDIX D: SAR TISSUE SPECIFICATIONS		
APPENDIX E: SAR SYSTEM VALIDATION		
APPENDIX F: ANTENNA DIAGRAM & SAR TEST SETUP PHOTOGRAPHS		
APPENDIX G: SENSOR TRIGGERING DATA SUMMARY		

FCC ID: ACJ9TGWW13B		SAR EVALUATION REPORT		Reviewed by: Quality Manager
Document S/N: OY1412152300.ACJ	Test Dates: 12/15/14 - 01/08/15	DUT Type: Wireless Module		Page 2 of 91

1 DEVICE UNDER TEST

1.1 Device Overview

Band & Mode	Operating Modes	Tx Frequency
GPRS/EDGE 850	Data	824.20 - 848.80 MHz
GPRS/EDGE 1900	Data	1850.20 - 1909.80 MHz
UMTS 850	Data	826.40 - 846.60 MHz
UMTS 1750	Data	1712.4 - 1752.5 MHz
UMTS 1900	Data	1852.4 - 1907.6 MHz
CDMA/EVDO BC10 (§90S)	Data	817.90 - 823.10 MHz
CDMA/EVDO BC0 (§22H)	Data	824.70 - 848.31 MHz
PCS CDMA/EVDO	Data	1851.25 - 1908.75 MHz
LTE Band 17	Data	706.5 - 713.5 MHz
LTE Band 13	Data	779.5 - 784.5 MHz
LTE Band 5 (Cell)	Data	824.7 - 848.3 MHz
LTE Band 4 (AWS)	Data	1710.7 - 1754.3 MHz
LTE Band 2 (PCS)	Data	1850.7 - 1909.3 MHz
LTE Band 25 (PCS)	Data	1850.7 - 1914.3 MHz

1.2 Power Reduction for SAR



This device uses a proximity sensor for SAR compliance. The proximity sensor is activated when used in close proximity to the user's body. The proximity sensor triggers power reduction for data modes and is only applicable for tablet operations. Since the device is a full tablet size, the Body SAR was evaluated per FCC KDB Publication 616217 D04v01 for full sized tablets.

1.3 Nominal and Maximum Output Power Specifications

This device operates using the following maximum and nominal output power specifications. SAR values were scaled to the maximum allowed power to determine compliance per KDB Publication 447498 D01v05.

1.3.1 Maximum Power



Mode / Band		Burst Average GMSK (dBm)		Burst Average 8-PSK (dBm)			
		1 TX Slot	2 TX Slots	1 TX Slot	2 TX Slots	3 TX Slots	4 TX Slots
GPRS/EDGE 850	Maximum	33.5	33.5	28.0	28.0	28.0	28.0
	Nominal	32.5	32.5	27.0	27.0	27.0	27.0
GPRS/EDGE 1900	Maximum	30.5	30.5	27.0	27.0	27.0	27.0
	Nominal	29.5	29.5	26.0	26.0	26.0	26.0

FCC ID: ACJ9TGWW13B	 PCTEST ENGINEERING LABORATORY, INC.	SAR EVALUATION REPORT		Reviewed by: Quality Manager
Document S/N: OY1412152300.ACJ	Test Dates: 12/15/14 - 01/08/15	DUT Type: Wireless Module	Page 3 of 91	

Mode / Band		Modulated Average (dBm)			
		<i>3GPP Rel. 99 RMC</i>	<i>3GPP Rel. 5 HSDPA</i>	<i>3GPP Rel. 6 HSUPA</i>	<i>3GPP Rel. 8. DC-HSDPA</i>
UMTS Band 5 (850 MHz)	Maximum	24.0	23.0	23.0	23.0
	Nominal	23.0	22.0	22.0	22.0
UMTS Band 4 (1750 MHz)	Maximum	24.0	23.0	23.0	23.0
	Nominal	23.0	22.0	22.0	22.0
UMTS Band 2 (1900 MHz)	Maximum	24.0	23.0	23.0	23.0
	Nominal	23.0	22.0	22.0	22.0

Mode / Band		Modulated Average (dBm)
CDMA/EVDO BC10 (\$90S)	Maximum	25.0
	Nominal	24.0
CDMA/EVDO BC0 (\$22H)	Maximum	25.0
	Nominal	24.0
PCS CDMA/EVDO	Maximum	25.0
	Nominal	24.0

Mode / Band		Modulated Average (dBm)
LTE Band 17	Maximum	24.0
	Nominal	23.0
LTE Band 13	Maximum	24.0
	Nominal	23.0
LTE Band 5 (Cell)	Maximum	24.0
	Nominal	23.0
LTE Band 4 (AWS)	Maximum	24.0
	Nominal	23.0
LTE Band 2 (PCS)	Maximum	24.0
	Nominal	23.0
LTE Band 25 (PCS)	Maximum	24.0
	Nominal	23.0

FCC ID: ACJ9TGWW13B	 PCTEST ENGINEERING LABORATORY, INC.	SAR EVALUATION REPORT		Reviewed by: Quality Manager
Document S/N: 0Y1412152300.ACJ	Test Dates: 12/15/14 - 01/08/15	DUT Type: Wireless Module		Page 4 of 91



1.3.2 Reduced Power – Body at 0 mm:

Mode / Band		Burst Average GMSK (dBm)		Burst Average 8-PSK (dBm)			
		1 TX Slot	2 TX Slots	1 TX Slot	2 TX Slots	3 TX Slots	4 TX Slots
GPRS/EDGE 850	Maximum	26.5	25.0	25.5	24.5	22.5	21.5
	Nominal	25.5	24.0	24.5	23.5	21.5	20.5
GPRS/EDGE 1900	Maximum	20.5	18.0	21.0	17.5	15.5	14.5
	Nominal	19.5	17.0	20.0	16.5	14.5	13.5

Mode / Band		Modulated Average (dBm)			
		3GPP Rel. 99 RMC	3GPP Rel. 5 HSDPA	3GPP Rel. 6 HSUPA	3GPP Rel. 8 DC-HSDPA
UMTS Band 5 (850 MHz)	Maximum	17.5	17.0	17.0	17.0
	Nominal	16.5	16.0	16.0	16.0
UMTS Band 4 (1750 MHz)	Maximum	10.0	9.5	9.5	9.5
	Nominal	9.0	8.5	8.5	8.5
UMTS Band 2 (1900 MHz)	Maximum	11.5	11.5	11.5	11.5
	Nominal	10.5	10.5	10.5	10.5

Mode / Band		Modulated Average (dBm)
CDMA/EVDO BC10 (§90S)	Maximum	18.0
	Nominal	17.0
CDMA/EVDO BC0 (§22H)	Maximum	18.0
	Nominal	17.0
PCS CDMA/EVDO	Maximum	11.5
	Nominal	10.5

Mode / Band		Modulated Average (dBm)
LTE Band 17	Maximum	17.0
	Nominal	16.0
LTE Band 13	Maximum	17.0
	Nominal	16.0
LTE Band 5 (Cell)	Maximum	17.0
	Nominal	16.0
LTE Band 4 (AWS)	Maximum	11.0
	Nominal	10.0
LTE Band 2 (PCS)	Maximum	12.0
	Nominal	11.0
LTE Band 25 (PCS)	Maximum	12.0
	Nominal	11.0

FCC ID: ACJ9TGWW13B	 PCTEST ENGINEERING LABORATORY, INC.	SAR EVALUATION REPORT	 Panasonic	Reviewed by: Quality Manager
Document S/N: OY1412152300.ACJ	Test Dates: 12/15/14 - 01/08/15	DUT Type: Wireless Module	Page 5 of 91	

1.4 Sides for SAR Testing

**Table 1-1
Sides for SAR Testing**

Mode	Back	Top	Bottom	Right	Left
GPRS 850	Yes	Yes	No	Yes	Yes
GPRS 1900	Yes	Yes	No	Yes	Yes
UMTS 850	Yes	Yes	No	Yes	Yes
UMTS 1750	Yes	Yes	No	Yes	Yes
UMTS 1900	Yes	Yes	No	Yes	Yes
EVDO BC10 (§90S)	Yes	Yes	No	Yes	Yes
EVDO BC0 (§22H)	Yes	Yes	No	Yes	Yes
PCS EVDO	Yes	Yes	No	Yes	Yes
LTE Band 17	Yes	Yes	No	Yes	Yes
LTE Band 13	Yes	Yes	No	Yes	Yes
LTE Band 5 (Cell)	Yes	Yes	No	Yes	Yes
LTE Band 4 (AWS)	Yes	Yes	No	Yes	Yes
LTE Band 25 (PCS)	Yes	Yes	No	Yes	Yes

Note:

1. Exact antenna dimensions and separation distances are shown in the Technical Descriptions in the device filing.
2. Overall device dimension is >20.0 cm.
3. Antenna locations can be found in Appendix F.
4. Per FCC KDB 616217 D04v01r01, Particular DUT edges were not required to be evaluated for SAR based on the SAR exclusion threshold in KDB 447498 D01v05r01.

1.5 Near Field Communication (NFC) Antenna

RFID transmitter ACJ9TGRI14D is integrated into this DUT. Therefore, all SAR tests were performed with the device which already incorporates the NFC antenna. A diagram showing the location of the NFC antenna can be found in Appendix F.

1.6 Simultaneous Transmission Capabilities



According to FCC KDB Publication 447498 D05v01, transmitters are considered to be transmitting simultaneously when there is overlapping transmission, with the exception of transmissions during network hand-offs with maximum hand-off duration less than 30 seconds. The FZ-R1 contains BT/WIFI transmitter ACJ9TGWL13A and can transmit simultaneously with this transmitter. Possible transmission paths for the DUT are shown in Figure 1-1 and are color-coded to indicate communication modes which share the same path. Modes which share the same transmission path cannot transmit simultaneously with one another. This device supports MIMO Tx for WLAN 802.11n/ac. Each WLAN antenna can transmit independently or together when operating with MIMO.



Figure 1-1

Simultaneous Transmission Paths

This device contains multiple transmitters that may operate simultaneously, and therefore requires a simultaneous transmission analysis according to FCC KDB Publication 447498 D01v05 3) procedures.

FCC ID: ACJ9TGWW13B	 PCTEST ENGINEERING LABORATORY, INC.	SAR EVALUATION REPORT		Reviewed by: Quality Manager
Document S/N: 0Y1412152300.ACJ	Test Dates: 12/15/14 - 01/08/15	DUT Type: Wireless Module	Page 6 of 91	

**Table 1-2
Simultaneous Transmission Scenarios**

No.	Capable Transmit Configuration	Body	Notes
1	GPRS/EDGE + 2.4 GHz WI-FI	Yes	
2	GPRS/EDGE + 2.4 GHz Bluetooth	Yes	
3	GPRS/EDGE + 5 GHz WI-FI	Yes	
4	UMTS + 2.4 GHz WI-FI	Yes	
5	UMTS + 5 GHz WI-FI	Yes	
6	UMTS + 2.4 GHz Bluetooth	Yes	
7	LTE + 2.4 GHz WI-FI	Yes	
8	LTE + 5 GHz WI-FI	Yes	
9	LTE + 2.4 GHz Bluetooth	Yes	
10	CDMA/EVDO data + 2.4 GHz WI-FI	Yes	
11	CDMA/EVDO data + 5 GHz WI-FI	Yes	
12	CDMA/EVDO data + 2.4 GHz Bluetooth	Yes	
13	CDMA/EVDO data + LTE	N/A	Not supported by HW

1. All licensed modes share the same antenna path and cannot transmit simultaneously 2.4 GHz.
2. WLAN, 5 GHz WLAN, and 2.4 GHz Bluetooth share the same antenna path and cannot transmit simultaneously.
3. This device supports 2x2 MIMO Tx for WLAN 802.11n/ac. Each WLAN antenna can transmit independently or together when operating with MIMO.

1.7 Miscellaneous SAR Test Considerations

(A) Licensed Transmitter(s)

This module is integrated into a tablet device with a unique form factor with sloped edges. Please see Section 5.2 for additional SAR test considerations, per FCC Guidance.



This device is only capable of QPSK HSUPA in the uplink. Therefore, no additional SAR tests are required beyond that described for devices with HSUPA in KDB 941225 D01v02.

LTE SAR for the higher modulations and lower bandwidths were not tested since the maximum average output power of all required channels and configurations was not more than 0.5 dB higher than the highest bandwidth; and the reported LTE SAR for the highest bandwidth was less than 1.45 W/kg for all configurations according to FCC KDB 941225 D05v02.

This device supports both LTE Band 25 and LTE Band 2. Since the supported frequency span for LTE Band 2 falls completely within the supported frequency span for LTE Band 25, both LTE bands have the same target power, and both LTE bands share the same transmission path, SAR was only assessed for LTE Band 25.

1.8 Guidance Applied



- FCC KDB Publication 941225 D01v03, D05v02r03 (2G/3G/4G)
- FCC KDB Publication 447498 D01v05r02 (General SAR Guidance)
- FCC KDB Publication 865664 D01v01r03, D02v01r01 (SAR Measurements up to 6 GHz)
- FCC KDB Publication 616217 D04v01r01 (Tablet SAR Consideration)
- October 2013 TCB Workshop Notes (GPRS Testing Considerations)

FCC ID: ACJ9TGWW13B	 PCTEST ENGINEERING LABORATORY, INC.	SAR EVALUATION REPORT		Reviewed by: Quality Manager
Document S/N: OY1412152300.ACJ	Test Dates: 12/15/14 - 01/08/15	DUT Type: Wireless Module		Page 7 of 91

1.9 Device Serial Numbers

Several samples were used with identical hardware to support SAR testing. Power level was configured for testing via software only available to the manufacturer (end user cannot control power level) per KDB 616217. The manufacturer has confirmed that the device(s) tested have the same mechanical and thermal characteristics and are within operational tolerances expected for production units.



Mode/Band	Max Power Serial Number	Reduced Power Serial Number
GPRS/EDGE 850	SAR-4	SAR-1
GPRS/EDGE 1900	SAR-3	SAR-3
UMTS 850	SAR-4	SAR-4
UMTS 1750	SAR-3	SAR-3
UMTS 1900	SAR-3	SAR-3
CDMA/EVDO BC10 (§90S)	SAR-3	SAR-3
CDMA/EVDO BC0 (§22H)	SAR-3	SAR-3
PCS CDMA/EVDO	SAR-3	SAR-3
LTE Band 17	SAR-5	SAR-5
LTE Band 13	SAR-5	SAR-5
LTE Band 5 (Cell)	SAR-5	SAR-5
LTE Band 4 (AWS)	SAR-5	SAR-5
LTE Band 25 (PCS)	SAR-4	SAR-4

FCC ID: ACJ9TGWW13B	 PCTEST ENGINEERING LABORATORY, INC.	SAR EVALUATION REPORT		Reviewed by: Quality Manager
Document S/N: 0Y1412152300.ACJ	Test Dates: 12/15/14 - 01/08/15	DUT Type: Wireless Module		Page 8 of 91

2

LTE INFORMATION

LTE Information			
FCC ID	ACJ9TGWW13B		
Form Factor	Wireless Module		
Frequency Range of each LTE transmission band	LTE Band 17 (706.5 - 713.5 MHz)		
	LTE Band 13 (779.5 - 784.5 MHz)		
	LTE Band 5 (Cell) (824.7 - 848.3 MHz)		
	LTE Band 4 (AWS) (1710.7 - 1754.3 MHz)		
	LTE Band 2 (PCS) (1850.7 - 1909.3 MHz)		
	LTE Band 25 (PCS) (1850.7 - 1914.3 MHz)		
Channel Bandwidths	LTE Band 17: 5 MHz, 10 MHz		
	LTE Band 13: 5 MHz, 10 MHz		
	LTE Band 5 (Cell): 1.4 MHz, 3 MHz, 5 MHz, 10 MHz		
	LTE Band 4 (AWS): 1.4 MHz, 3 MHz, 5 MHz, 10 MHz, 15 MHz, 20 MHz		
	LTE Band 2 (PCS): 1.4 MHz, 3 MHz, 5 MHz, 10 MHz, 15 MHz, 20 MHz		
LTE Band 25 (PCS): 1.4 MHz, 3 MHz, 5 MHz, 10 MHz, 15 MHz, 20 MHz			
Channel Numbers and Frequencies (MHz)	Low	Mid	High
LTE Band 17: 5 MHz	706.5 (23755)	710 (23790)	713.5 (23825)
LTE Band 17: 10 MHz	709 (23780)	710 (23790)	711 (23800)
LTE Band 13: 5 MHz	779.5 (23205)	782 (23230)	784.5 (23255)
LTE Band 13: 10 MHz	782 (23230)	782 (23230)	782 (23230)
LTE Band 5 (Cell): 1.4 MHz	824.7 (20407)	836.5 (20525)	848.3 (20643)
LTE Band 5 (Cell): 3 MHz	825.5 (20415)	836.5 (20525)	847.5 (20635)
LTE Band 5 (Cell): 5 MHz	826.5 (20425)	836.5 (20525)	846.5 (20625)
LTE Band 5 (Cell): 10 MHz	829 (20450)	836.5 (20525)	844 (20600)
LTE Band 4 (AWS): 1.4 MHz	1710.7 (19957)	1732.5 (20175)	1754.3 (20393)
LTE Band 4 (AWS): 3 MHz	1711.5 (19965)	1732.5 (20175)	1753.5 (20385)
LTE Band 4 (AWS): 5 MHz	1712.5 (19975)	1732.5 (20175)	1752.5 (20375)
LTE Band 4 (AWS): 10 MHz	1715 (20000)	1732.5 (20175)	1750 (20350)
LTE Band 4 (AWS): 15 MHz	1717.5 (20025)	1732.5 (20175)	1747.5 (20325)
LTE Band 4 (AWS): 20 MHz	1720 (20050)	1732.5 (20175)	1745 (20300)
LTE Band 2 (PCS): 1.4 MHz	1850.7 (18607)	1880 (18900)	1909.3 (19193)
LTE Band 2 (PCS): 3 MHz	1851.5 (18615)	1880 (18900)	1908.5 (19185)
LTE Band 2 (PCS): 5 MHz	1852.5 (18625)	1880 (18900)	1907.5 (19175)
LTE Band 2 (PCS): 10 MHz	1855 (18650)	1880 (18900)	1905 (19150)
LTE Band 2 (PCS): 15 MHz	1857.5 (18675)	1880 (18900)	1902.5 (19125)
LTE Band 2 (PCS): 20 MHz	1860 (18700)	1880 (18900)	1900 (19100)
LTE Band 25 (PCS): 1.4 MHz	1850.7 (26047)	1882.5 (26365)	1914.3 (26683)
LTE Band 25 (PCS): 3 MHz	1851.5 (26055)	1882.5 (26365)	1913.5 (26675)
LTE Band 25 (PCS): 5 MHz	1852.5 (26065)	1882.5 (26365)	1912.5 (26665)
LTE Band 25 (PCS): 10 MHz	1855 (26090)	1882.5 (26365)	1910 (26640)
LTE Band 25 (PCS): 15 MHz	1857.5 (26115)	1882.5 (26365)	1907.5 (26615)
LTE Band 25 (PCS): 20 MHz	1860 (26140)	1882.5 (26365)	1905 (26590)
UE Category	3		
Modulations Supported in UL	QPSK, 16QAM		
LTE MPR Permanently implemented per 3GPP TS 36.101 section 6.2.3~6.2.5? (manufacturer attestation to be provided)	YES		
A-MPR (Additional MPR) disabled for SAR Testing?	YES		

FCC ID: ACJ9TGWW13B		SAR EVALUATION REPORT		Reviewed by: Quality Manager
Document S/N: OY1412152300.ACJ	Test Dates: 12/15/14 - 01/08/15	DUT Type: Wireless Module	Page 9 of 91	

3 INTRODUCTION

The FCC and Industry Canada have adopted the guidelines for evaluating the environmental effects of radio frequency (RF) radiation in ET Docket 93-62 on Aug. 6, 1996 and Health Canada Safety Code 6 to protect the public and workers from the potential hazards of RF emissions due to FCC-regulated portable devices. [1]

The safety limits used for the environmental evaluation measurements are based on the criteria published by the American National Standards Institute (ANSI) for localized specific absorption rate (SAR) in IEEE/ANSI C95.1-1992 Standard for Safety Levels with Respect to Human Exposure to Radio Frequency Electromagnetic Fields, 3 kHz to 300 GHz [3] and Health Canada RF Exposure Guidelines Safety Code 6 [22]. The measurement procedure described in IEEE/ANSI C95.3-2002 Recommended Practice for the Measurement of Potentially Hazardous Electromagnetic Fields - RF and Microwave [4] is used for guidance in measuring the Specific Absorption Rate (SAR) due to the RF radiation exposure from the Equipment Under Test (EUT). These criteria for SAR evaluation are similar to those recommended by the International Committee for Non-Ionizing Radiation Protection (ICNIRP) in Biological Effects and Exposure Criteria for Radiofrequency Electromagnetic Fields,” Report No. Vol 74. SAR is a measure of the rate of energy absorption due to exposure to an RF transmitting source. SAR values have been related to threshold levels for potential biological hazards.

3.1 SAR Definition

Specific Absorption Rate is defined as the time derivative (rate) of the incremental energy (dU) absorbed by (dissipated in) an incremental mass (dm) contained in a volume element (dV) of a given density (ρ). It is also defined as the rate of RF energy absorption per unit mass at a point in an absorbing body (see Equation 3-1).

Equation 3-1
SAR Mathematical Equation

$$SAR = \frac{d}{dt} \left(\frac{dU}{dm} \right) = \frac{d}{dt} \left(\frac{dU}{\rho dv} \right)$$



SAR is expressed in units of Watts per Kilogram (W/kg).

$$SAR = \frac{\sigma \cdot E^2}{\rho}$$

where:

- σ = conductivity of the tissue-simulating material (S/m)
- ρ = mass density of the tissue-simulating material (kg/m^3)
- E = Total RMS electric field strength (V/m)

NOTE: The primary factors that control rate of energy absorption were found to be the wavelength of the incident field in relation to the dimensions and geometry of the irradiated organism, the orientation of the organism in relation to the polarity of field vectors, the presence of reflecting surfaces, and whether conductive contact is made by the organism with a ground plane.[6]

FCC ID: ACJ9TGWW13B	 PCTEST ENGINEERING LABORATORY, INC.	SAR EVALUATION REPORT		Reviewed by: Quality Manager
Document S/N: 0Y1412152300.ACJ	Test Dates: 12/15/14 - 01/08/15	DUT Type: Wireless Module		Page 10 of 91

4 DOSIMETRIC ASSESSMENT

4.1 Measurement Procedure

The evaluation was performed using the following procedure compliant to FCC KDB Publication 865664 D01v01 and IEEE 1528-2013:

1. The SAR distribution at the exposed side of the head or body was measured at a distance no greater than 5.0 mm from the inner surface of the shell. The area covered the entire dimension of the device-head and body interface and the horizontal grid resolution was determined per FCC KDB Publication 865664 D01v01 (See Table 4-1) and IEEE 1528-2013.
2. The point SAR measurement was taken at the maximum SAR region determined from Step 1 to enable the monitoring of SAR fluctuations/drifts during the 1g/10g cube evaluation. SAR at this fixed point was measured and used as a reference value.
3. Based on the area scan data, the peak of the region with maximum SAR was determined by spline interpolation. Around this point, a volume was assessed according to the measurement resolution and volume size requirements of FCC KDB Publication 865664 D01v01 (See Table 4-1) and IEEE 1528-2013. On the basis of this data set, the spatial peak SAR value was evaluated with the following procedure (see references or the DASYS manual online for more details):
 - a. SAR values at the inner surface of the phantom are extrapolated from the measured values along the line away from the surface with spacing no greater than that in Table 4-1. The extrapolation was based on a least-squares algorithm. A polynomial of the fourth order was calculated through the points in the z-axis (normal to the phantom shell).
 - b. After the maximum interpolated values were calculated between the points in the cube, the SAR was averaged over the spatial volume (1g or 10g) using a 3D-Spline interpolation algorithm. The 3D-spline is composed of three one-dimensional splines with the “Not a knot” condition (in x, y, and z directions). The volume was then integrated with the trapezoidal algorithm. One thousand points (10 x 10 x 10) were obtained through interpolation, in order to calculate the averaged SAR.
 - c. All neighboring volumes were evaluated until no neighboring volume with a higher average value was found.
4. The SAR reference value, at the same location as step 2, was re-measured after the zoom scan was complete to calculate the SAR drift. If the drift deviated by more than 5%, the SAR test and drift measurements were repeated.

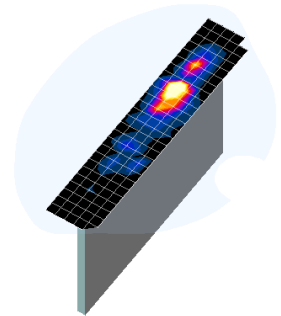



Figure 4-1
Sample SAR Area Scan

Table 4-1
Area and Zoom Scan Resolutions per FCC KDB Publication 865664 D01v01*

Frequency	Maximum Area Scan Resolution (mm) ($\Delta x_{area}, \Delta y_{area}$)	Maximum Zoom Scan Resolution (mm) ($\Delta x_{zoom}, \Delta y_{zoom}$)	Maximum Zoom Scan Spatial Resolution (mm)			Minimum Zoom Scan Volume (mm) (x,y,z)
			Uniform Grid $\Delta z_{zoom}(n)$	Graded Grid		
				$\Delta z_{zoom}(1)^*$	$\Delta z_{zoom}(n>1)^*$	
≤ 2 GHz	≤ 15	≤ 8	≤ 5	≤ 4	≤ 1.5* $\Delta z_{zoom}(n-1)$	≥ 30
2-3 GHz	≤ 12	≤ 5	≤ 5	≤ 4	≤ 1.5* $\Delta z_{zoom}(n-1)$	≥ 30
3-4 GHz	≤ 12	≤ 5	≤ 4	≤ 3	≤ 1.5* $\Delta z_{zoom}(n-1)$	≥ 28
4-5 GHz	≤ 10	≤ 4	≤ 3	≤ 2.5	≤ 1.5* $\Delta z_{zoom}(n-1)$	≥ 25
5-6 GHz	≤ 10	≤ 4	≤ 2	≤ 2	≤ 1.5* $\Delta z_{zoom}(n-1)$	≥ 22

*Also compliant to IEEE 1528-2013 Table 6

FCC ID: ACJ9TGWW13B	 PCTEST ENGINEERING LABORATORY, INC.	SAR EVALUATION REPORT		Reviewed by: Quality Manager
Document S/N: OY1412152300.ACJ	Test Dates: 12/15/14 - 01/08/15	DUT Type: Wireless Module		Page 11 of 91

5 SAR TESTING PROCEDURES

5.1 SAR Testing for Tablet per KDB Publication 616217 D04

This device is used in full sized tablet exposure conditions due to its size. Per FCC KDB 616217, the back surface and edges of the tablet should be tested for SAR compliance with the tablet touching the phantom. The SAR Exclusion Threshold in KDB 447498 D01v05 can be applied to determine SAR test exclusion for adjacent edge configurations. The closest distance from the antenna to an adjacent tablet edge is used to determine if SAR testing is required for the adjacent edges, with the adjacent edge positioned against the phantom and the edge containing the antenna positioned perpendicular to the phantom.

5.2 SAR Test Positioning Based on Form Factor

A non-standard setup was used for SAR testing based on guidance from the FCC. The operational description contains additional information.

This tablet has sloped surfaces at the edges of the device. Per FCC guidance, two device orientations were considered to evaluate each required edge SAR based on the considerations of possible usage position from end-users and worst case exposure scenarios. Per KDB 616217 D04 for SAR testing for Tablets, the device at reduced power was first positioned with the required edge touching (0mm) and perpendicular to the flat phantom. Additionally, the device was then positioned with the sloped edge touching (0mm) the flat phantom. SAR testing was performed on sloped edges (top-back surface, right-back surface, and left-back surface) when SAR testing was required per the exclusion formula in KDB Publication 447498. Maximum power SAR testing on the required device sides and edges was performed at the same perpendicular and sloped orientations at the SAR test distance per FCC KDB 616217 D04. The Technical Descriptions in the FCC Filing contain additional information regarding device positioning. The data for both orientations for each required edge is included in Section 9.



5.3 Additional Test Positions due to Proximity Sensor Considerations

This device uses a proximity sensor to reduce data powers in tablet-device use conditions.

While the device's antenna is within a certain distance of the user, the sensor activates and reduces the maximum output power allowed. However, the sensor is not active when the device is moved beyond the sensor triggering distance and the maximum output power is no longer limited. Therefore, an additional exposure condition is needed in the vicinity of the triggering distance to ensure SAR is compliant when the device is allowed to operate at a non-reduced output power level.

FCC KDB 616217 D04 Section 6 was used as a guideline for selecting SAR test distances for this device at these additional exposure conditions. Since the proximity sensor activation distance for the back side of the device is 19 mm, a conservative distance of 18 mm was tested for SAR on the back side at maximum power. Since the proximity sensor activation distance for the top edge and sloped top edge (top-back surface) of the device is 17 mm, a conservative distance of 16 mm was tested for SAR for these edges. Since the proximity sensor activation distance for the right edge and sloped right edge (right-back surface) of the device is 4 mm, a conservative distance of 3 mm was tested for SAR for these edges. Sensor triggering distance summary data is included in Appendix G.

The sensor is designed to support sufficient detection range and sensitivity to cover regions of the sensors in all applicable directions since the sensor entirely covers the antenna.

FCC ID: ACJ9TGWW13B	 PCTEST ENGINEERING LABORATORY, INC.	SAR EVALUATION REPORT	 Panasonic	Reviewed by: Quality Manager
Document S/N: OY1412152300.ACJ	Test Dates: 12/15/14 - 01/08/15	DUT Type: Wireless Module		Page 12 of 91

6

RF EXPOSURE LIMITS

6.1 Uncontrolled Environment

UNCONTROLLED ENVIRONMENTS are defined as locations where there is the exposure of individuals who have no knowledge or control of their exposure. The general population/uncontrolled exposure limits are applicable to situations in which the general public may be exposed or in which persons who are exposed as a consequence of their employment may not be made fully aware of the potential for exposure or cannot exercise control over their exposure. Members of the general public would come under this category when exposure is not employment-related; for example, in the case of a wireless transmitter that exposes persons in its vicinity.



6.2 Controlled Environment

CONTROLLED ENVIRONMENTS are defined as locations where there is exposure that may be incurred by persons who are aware of the potential for exposure, (i.e. as a result of employment or occupation). In general, occupational/controlled exposure limits are applicable to situations in which persons are exposed as a consequence of their employment, who have been made fully aware of the potential for exposure and can exercise control over their exposure. This exposure category is also applicable when the exposure is of a transient nature due to incidental passage through a location where the exposure levels may be higher than the general population/uncontrolled limits, but the exposed person is fully aware of the potential for exposure and can exercise control over his or her exposure by leaving the area or by some other appropriate means.

**Table 6-1
SAR Human Exposure Specified in ANSI/IEEE C95.1-1992 and Health Canada Safety Code 6**

HUMAN EXPOSURE LIMITS		
	UNCONTROLLED ENVIRONMENT <i>General Population</i> (W/kg) or (mW/g)	CONTROLLED ENVIRONMENT <i>Occupational</i> (W/kg) or (mW/g)
Peak Spatial Average SAR Head	1.6	8.0
Whole Body SAR	0.08	0.4
Peak Spatial Average SAR Hands, Feet, Ankle, Wrists, etc.	4.0	20

1. The Spatial Peak value of the SAR averaged over any 1 gram of tissue (defined as a tissue volume in the shape of a cube) and over the appropriate averaging time.
2. The Spatial Average value of the SAR averaged over the whole body.
3. The Spatial Peak value of the SAR averaged over any 10 grams of tissue (defined as a tissue volume in the shape of a cube) and over the appropriate averaging time.

FCC ID: ACJ9TGWW13B	 PCTEST ENGINEERING LABORATORY, INC.	SAR EVALUATION REPORT		Reviewed by: Quality Manager
Document S/N: OY1412152300.ACJ	Test Dates: 12/15/14 - 01/08/15	DUT Type: Wireless Module	Page 13 of 91	

Power measurements were performed using a base station simulator under digital average power.

7.1 Measured and Reported SAR

Per FCC KDB Publication 447498 D01v05, When SAR is not measured at the maximum power level allowed for production units, the results must be scaled to the maximum tune-up tolerance limit according to the power applied to the individual channels tested to determine compliance. For simultaneous transmission, the measured aggregate SAR must be scaled according to the sum of the differences between the maximum tune-up tolerance and actual power used to test each transmitter. When SAR is measured at or scaled to the maximum tune-up tolerance limit, the results are referred to as *reported* SAR. The highest *reported* SAR results are identified on the grant of equipment authorization according to procedures in KDB 690783 D01v01r02.

7.2 Procedures Used to Establish RF Signal for SAR

The following procedures are according to FCC KDB Publication 941225 D01 "SAR Measurement Procedures for 3G Devices" v02, October 2007.

The device was placed into a simulated call using a base station simulator in a RF shielded chamber. Establishing connections in this manner ensure a consistent means for testing SAR and are recommended for evaluating SAR [4]. Devices under test were evaluated prior to testing, with a fully charged battery and were configured to operate at maximum output power. In order to verify that the device was tested throughout the SAR test at maximum output power, the SAR measurement system measures a "point SAR" at an arbitrary reference point at the start and end of the 1 gram SAR evaluation, to assess for any power drifts during the evaluation. If the power drift deviated by more than 5%, the SAR test and drift measurements were repeated.



7.3 SAR Measurement Conditions for CDMA2000

The following procedures were performed according to FCC KDB Publication 941225 D01 "SAR Measurement Procedures for 3G Devices" v02, October 2007.

7.3.1 Output Power Verification

See 3GPP2 C.S0011/TIA-98-E as recommended by "SAR Measurement Procedures for 3G Devices" v02, October 2007. Maximum output power is verified on the High, Middle and Low channels according to procedures in section 4.4.5.2 of 3GPP2 C.S0011/TIA-98-E. SO55 tests were measured with power control bits in the "All Up" condition.

1. If the mobile station (MS) supports Reverse TCH RC 1 and Forward TCH RC 1, set up a call using Fundamental Channel Test Mode 1 (RC=1/1) with 9600 bps data rate only.
2. Under RC1, C.S0011 Table 4.4.5.2-1, Table 7-1 parameters were applied.
3. If the MS supports the RC 3 Reverse FCH, RC3 Reverse SCH₀ and demodulation of RC 3,4, or 5, set up a call using Supplemental Channel Test Mode 3 (RC 3/3) with 9600 bps Fundamental Channel and 9600 bps SCH₀ data rate.
4. Under RC3, C.S0011 Table 4.4.5.2-2, Table 7-2 was applied.

FCC ID: ACJ9TGWW13B	 PCTEST ENGINEERING LABORATORY, INC.	SAR EVALUATION REPORT		Reviewed by: Quality Manager
Document S/N: OY1412152300.ACJ	Test Dates: 12/15/14 - 01/08/15	DUT Type: Wireless Module		Page 14 of 91

**Table 7-1
Parameters for Max. Power for RC1**

Parameter	Units	Value
I_{or}	dBm/1.23 MHz	-104
$\frac{Pilot E_c}{I_{or}}$	dB	-7
$\frac{Traffic E_c}{I_{or}}$	dB	-7.4

**Table 7-2
Parameters for Max. Power for RC3**

Parameter	Units	Value
I_{or}	dBm/1.23 MHz	-86
$\frac{Pilot E_c}{I_{or}}$	dB	-7
$\frac{Traffic E_c}{I_{or}}$	dB	-7.4

5. FCHs were configured at full rate for maximum SAR with “All Up” power control bits.

7.3.2 Body SAR Measurements for EVDO Data Devices

Body SAR is measured using Subtype 0/1 Physical Layer configurations for Rev. 0 per KDB Publication 941225 D01 procedures for “1x Ev-Do data Devices”. SAR for Subtype 2 Physical layer configurations is not required for Rev. A when the maximum average output of each RF channels is less than that measured in Subtype 0/1 Physical layer configurations. Otherwise, SAR is measured on the maximum output channel for Rev. A using the exposure configuration that results in the highest SAR for the RF channels in Rev. 0. The AT is tested with a Reverse Data Channel rate of 153.6 kbps in Subtype 0/1 Physical Layer configurations; and a Reverse Data Channel payload size of 4096 bits and Termination Target of 16 slots in Subtype 2 Physical Layer configurations.

SAR is not required for 1x RTT for Ev-Do devices that also support 1x RTT voice and/or data operations, when the maximum average output of each channel is less than 1/4 dB higher than that measured in Subtype 0/1 Physical Layer configurations for Rev. 0. Otherwise, CDMA “Body-SAR Measurement” procedures for “CDMA 2000 1x Handsets” were applied.

7.4 SAR Measurement Conditions for UMTS

7.4.1 Output Power Verification

Maximum output power is measured on the High, Middle and Low channels for each applicable transmission band according to the general descriptions in section 5.2 of 3GPP TS 34.121, using the appropriate RMC or AMR with TPC (transmit power control) set to all “1s”.



Maximum output power is verified on the High, Middle and Low channels according to the general descriptions in section 5.2 of 3GPP TS 34.121 (release 5), using the appropriate RMC with TPC (transmit power control) set to all “1s” or applying the required inner loop power control procedures to maintain maximum output power while HSUPA is active. Results for all applicable physical channel configurations (DPCCH, DPDCHn and spreading codes, HS-DPCCH etc) are tabulated in this test report. All configurations that are not supported by the DUT or cannot be measured due to technical or equipment limitations are identified.

7.4.2 Body SAR Measurements

SAR for body exposure configurations is measured using the 12.2 kbps RMC with the TPC bits all “1s”.

7.4.3 Procedures Used to Establish RF Signal for SAR HSDPA Data Devices

The following procedures are applicable to HSDPA data devices operating under 3GPP Release 5. Body exposure conditions are typically applicable to these devices, including handsets and data modems operating in various electronic devices. HSDPA operates in conjunction with UMTS and requires an active DPCCH. The default test configuration is to measure SAR in UMTS without HSDPA, with an established radio link between the DUT and a communication test set with 12.2 kbps RMC mode configured in Test Loop Mode 1; and tested with HSDPA with FRC and a 12.2 kbps RMC using the highest SAR configuration in UMTS. SAR is selectively confirmed for other physical channel configurations according to output power, exposure conditions and device operating capabilities. Maximum output power is verified according to 3GPP TS 23.121 (Release 5) and SAR must be measured according to these maximum output conditions.

FCC ID: ACJ9TGWW13B	 PCTEST ENGINEERING LABORATORY, INC.	SAR EVALUATION REPORT		Reviewed by: Quality Manager
Document S/N: OY1412152300.ACJ	Test Dates: 12/15/14 - 01/08/15	DUT Type: Wireless Module	Page 15 of 91	

Sub-Test	β_c	β_d	β_d (SF)	β_c/β_d	β_{HS} (Note 1, Note 2)	CM (dB) (Note 3)	MPR (dB) (Note 3)
1	2/15	15/15	64	2/15	4/15	0.0	0.0
2	12/15 (Note 4)	15/15 (Note 4)	64	12/15 (Note 4)	24/15	1.0	0.0
3	15/15	8/15	64	15/8	30/15	1.5	0.5
4	15/15	4/15	64	15/4	30/15	1.5	0.5

Note 1: Δ_{ACK} , Δ_{NACK} and $\Delta_{CQI} = 8 \Leftrightarrow A_{HS} = \beta_{HS}/\beta_c = 30/15 \Leftrightarrow \beta_{HS} = 30/15 * \beta_c$.

Note 2: For the HS-DPCCH power mask requirement test in clause 5.2.C, 5.7.A, and the Error Vector Magnitude (EVM) with HS-DPCCH test in clause 5.13.1A, and HSDPA EVM with phase discontinuity in clause 5.13.1AA, Δ_{ACK} and $\Delta_{NACK} = 8$ ($A_{HS} = 30/15$) with $\beta_{HS} = 30/15 * \beta_c$, and $\Delta_{CQI} = 7$ ($A_{HS} = 24/15$) with $\beta_{HS} = 24/15 * \beta_c$.

Note 3: CM = 1 for $\beta_c/\beta_d = 12/15$, $\beta_{HS}/\beta_c = 24/15$. For all other combinations of DPDCH, DPCCH and HS-DPCCH the MPR is based on the relative CM difference. This is applicable for only UEs that support HSDPA in release 6 and later releases.

Figure 7-1
Table C.10.1.4 of TS 234.121-1

7.4.4 SAR Measurement Conditions for HSUPA Data Devices

SAR for body exposure configurations are measured according to the ‘Body SAR Measurements’ procedures in the ‘WCDMA Handsets’ section of the KDB 941225 D01 FCC 3G document. In addition, Body SAR is also measured for HSPA when the maximum average output of each RF channel with HSPA active is at least ¼ dB higher of that measured without HSPA in 12.2 kbps RMC mode or the maximum SAR for 12.2 kbps RMC is above 75% of the SAR limit. Body SAR for HSPA is measured with E-DCH Sub-test 5, using H-Set 1 and QPSK for FRC and a 12.2 kbps RMC configured in Test Loop Mode 1 with power control algorithm 2, according to the highest body SAR configuration in 12.2 kbps RMC without HSPA. When VOIP is applicable for head exposure, SAR is not required when the maximum output of each RF channel with HSPA is less than ¼ dB higher than that measured using 12.2 kbps RMC; otherwise, the same HSPA configuration used for body measurements should be used to test for head exposure.

Due to inner loop power control requirements in HSPA, a commercial communication test set should be used for the output power and SAR tests. The 12.2 kbps RMC, FRC H-set 1 and EDCH configurations for HSPA should be configured according to the β values indicated below as well as other applicable procedures described in the ‘WCDMA Handset’ and ‘Release 5 HSDPA Data Devices’ sections of the FCC 3G document.

Sub-test	β_c	β_d	β_d (SF)	β_c/β_d	β_{HS} (1)	β_{HS}	β_{HS} (SF)	β_{HS} (codes)	CM (dB)	MPR (dB)	AG Index (4)	E-TFCI	
1	11/15 ⁽³⁾	15/15 ⁽³⁾	64	11/15 ⁽³⁾	22/15	209/225	1039/225	4	1	1.0	0.0	20	75
2	6/15	15/15	64	6/15	12/15	12/15	94/75	4	1	3.0	2.0	12	67
3	15/15	9/15	64	15/9	30/15	30/15	β_{HS} : 47/15 β_{HS} : 47/15	4	2	2.0	1.0	15	92
4	2/15	15/15	64	2/15	4/15	2/15	56/75	4	1	3.0	2.0	17	71
5	15/15 ⁽⁴⁾	15/15 ⁽⁴⁾	64	15/15 ⁽⁴⁾	30/15	24/15	134/15	4	1	1.0	0.0	21	81

Note 1: Δ_{ACK} , Δ_{NACK} and $\Delta_{CQI} = 8 \Leftrightarrow A_{HS} = \beta_{HS}/\beta_c = 30/15 \Leftrightarrow \beta_{HS} = 30/15 * \beta_c$.

Note 2: CM = 1 for $\beta_c/\beta_d = 12/15$, $\beta_{HS}/\beta_c = 24/15$. For all other combinations of DPDCH, DPCCH, HS-DPCCH, E-DPDCH and E-DPCCH the MPR is based on the relative CM difference.

Note 3: For subtest 1 the β_c/β_d ratio of 11/15 for the TFC during the measurement period (TF1, TF0) is achieved by setting the signaled gain factors for the reference TFC (TF1, TF1) to $\beta_c = 10/15$ and $\beta_d = 15/15$.



Note 4: For subtest 5 the β_c/β_d ratio of 15/15 for the TFC during the measurement period (TF1, TF0) is achieved by setting the signaled gain factors for the reference TFC (TF1, TF1) to $\beta_c = 14/15$ and $\beta_d = 15/15$.

Note 5: Testing UE using E-DPDCH Physical Layer category 1 Sub-test 3 is not required according to TS 25.306 Table 5.1g.

Note 6: β_{d4} can not be set directly; it is set by Absolute Grant Value.

7.4.5 SAR Measurement Conditions for DC-HSDPA

SAR test exclusion for DC-HSDPA devices is determined by power measurements according to the H-Set 12, Fixed Reference Channel (FRC) configuration in Table C.8.1.12 of 3GPP TS 34.121-1. A primary and a secondary serving HS-DSCH Cell are required to perform the power measurement and for the results to qualify for SAR test exclusion. DC-HSDPA uplink maximum output power measurements using the four Rel. 5 HSDPA subtests in Table C.10.1.4 of TS 234.121-1 is required.

FCC ID: ACJ9TGWW13B	 PCTEST ENGINEERING LABORATORY, INC.	SAR EVALUATION REPORT		Reviewed by: Quality Manager
Document S/N: OY1412152300.ACJ	Test Dates: 12/15/14 - 01/08/15	DUT Type: Wireless Module		Page 16 of 91

When the maximum average output power of each RF channel with DC-HSDPA active is $\leq 1/4$ dB higher than that measured using 12.2 kbps RMC, or the maximum reported SAR for 12.2 kbps RMC is $\leq 75\%$ of the SAR limit, SAR evaluation for DC-HSDPA is not required.

7.5 SAR Measurement Conditions for LTE

LTE modes were tested according to FCC KDB 941225 D05v02 publication. Please see notes after the tabulated SAR data for required test configurations. Establishing connections with base station simulators ensure a consistent means for testing SAR and are recommended for evaluating SAR [4]. The R&S CMW500 was used for LTE output power measurements and SAR testing. Closed loop power control was used so the UE transmits with maximum output power during SAR testing. SAR tests were performed with the same number of RB and RB offsets transmitting on all TTI frames (maximum TTI).

7.5.1 Spectrum Plots for RB Configurations

A properly configured base station simulator was used for SAR tests and power measurements. Therefore, spectrum plots for RB configurations were not required to be included in this report.

7.5.2 MPR

MPR is permanently implemented for this device by the manufacturer. The specific manufacturer target MPR is indicated alongside the SAR results. MPR is enabled for this device, according to 3GPP TS36.101 Section 6.2.3 – 6.2.5 under Table 6.2.3-1.



7.5.3 A-MPR

A-MPR (Additional MPR) has been disabled for all SAR tests by setting NS=01 on the base station simulator.

7.5.4 Required RB Size and RB Offsets for SAR Testing

According to FCC KDB 941225 D05v02r01:

- a. Per Section 5.2.1, SAR is required for QPSK 1 RB Allocation for the largest bandwidth
 - i. The required channel and offset combination with the highest maximum output power is required for SAR.
 - ii. When the reported SAR is ≤ 0.8 W/kg, testing of the remaining RB offset configurations and required test channels is not required. Otherwise, SAR is required for the remaining required test channels using the RB offset configuration with highest output power for that channel.
 - iii. When the reported SAR for a required test channel is > 1.45 W/kg, SAR is required for all RB offset configurations for that channel.
- b. Per Section 5.2.2, SAR is required for 50% RB allocation using the largest bandwidth following the same procedures outlined in Section 5.2.1.
- c. Per Section 5.2.3, QPSK SAR is not required for the 100% allocation when the highest maximum output power for the 100% allocation is less than the highest maximum output power of the 1 RB and 50% RB allocations and the reported SAR for the 1 RB and 50% RB allocations is < 0.8 W/kg.
- d. Per Section 5.2.4 and 5.3, SAR tests for higher order modulations and lower bandwidths configurations are not required when the conducted power of the required test configurations determined by Sections 5.2.1 through 5.2.3 is less than or equal to $1/2$ dB higher than the equivalent configuration using QPSK modulation and when the QPSK SAR for those configurations is < 1.45 W/kg.



FCC ID: ACJ9TGWW13B	 PCTEST ENGINEERING LABORATORY, INC.	SAR EVALUATION REPORT	 Panasonic	Reviewed by: Quality Manager
Document S/N: OY1412152300.ACJ	Test Dates: 12/15/14 - 01/08/15	DUT Type: Wireless Module	Page 17 of 91	

8 RF CONDUCTED POWERS

8.1 GPRS/EDGE Conducted Powers

Table 8-1
Maximum GPRS/EDGE Average RF Conducted Powers

		Maximum Burst-Averaged Output Power					
		<i>GPRS/EDGE Data (GMSK)</i>		<i>EDGE Data (8-PSK)</i>			
Band	Channel	GPRS [dBm] 1 Tx Slot	GPRS [dBm] 2 Tx Slot	EDGE [dBm] 1 Tx Slot	EDGE [dBm] 2 Tx Slot	EDGE [dBm] 3 Tx Slot	EDGE [dBm] 4 Tx Slot
GSM 850	128	32.07	32.06	26.63	26.77	26.38	26.23
	190	31.98	31.93	26.79	26.72	26.37	26.15
	251	31.85	31.83	26.75	26.65	26.35	26.07
GSM 1900	512	29.47	29.39	25.58	25.42	25.18	25.05
	661	29.42	29.53	25.73	25.66	25.43	25.30
	810	29.54	29.44	25.85	25.81	25.58	25.48
		Calculated Maximum Frame-Averaged Output Power					
		<i>GPRS/EDGE Data (GMSK)</i>		<i>EDGE Data (8-PSK)</i>			
Band	Channel	GPRS [dBm] 1 Tx Slot	GPRS [dBm] 2 Tx Slot	EDGE [dBm] 1 Tx Slot	EDGE [dBm] 2 Tx Slot	EDGE [dBm] 3 Tx Slot	EDGE [dBm] 4 Tx Slot
GSM 850	128	23.04	26.04	17.60	20.75	22.12	23.22
	190	22.95	25.91	17.76	20.70	22.11	23.14
	251	22.82	25.81	17.72	20.63	22.09	23.06
GSM 1900	512	20.44	23.37	16.55	19.40	20.92	22.04
	661	20.39	23.51	16.70	19.64	21.17	22.29
	810	20.51	23.42	16.82	19.79	21.32	22.47
GSM 850	Frame	23.47	26.48	17.97	20.98	22.74	23.99
GSM 1900	Avg.Targets:	20.47	23.48	16.97	19.98	21.74	22.99



FCC ID: ACJ9TGWW13B	 <small>ENGINEERING LABORATORY, INC.</small>	SAR EVALUATION REPORT		Reviewed by: Quality Manager
Document S/N: OY1412152300.ACJ	Test Dates: 12/15/14 - 01/08/15	DUT Type: Wireless Module		Page 18 of 91

**Table 8-2
Reduced GPRS/EDGE Average RF Conducted Powers**

		Maximum Burst-Averaged Output Power					
		GPRS/EDGE Data (GMSK)		EDGE Data (8-PSK)			
Band	Channel	GPRS [dBm] 1 Tx Slot	GPRS [dBm] 2 Tx Slot	EDGE [dBm] 1 Tx Slot	EDGE [dBm] 2 Tx Slot	EDGE [dBm] 3 Tx Slot	EDGE [dBm] 4 Tx Slot
GSM 850	128	26.26	24.24	24.74	23.57	21.60	20.84
	190	26.21	24.19	24.70	23.57	21.58	20.82
	251	26.16	23.76	24.64	23.59	21.61	20.77
GSM 1900	512	19.98	17.00	20.06	17.00	14.96	13.92
	661	20.42	17.33	20.53	17.25	15.17	14.19
	810	20.50	17.49	20.68	17.50	15.50	14.38
		Calculated Maximum Frame-Averaged Output Power					
		GPRS/EDGE Data (GMSK)		EDGE Data (8-PSK)			
Band	Channel	GPRS [dBm] 1 Tx Slot	GPRS [dBm] 2 Tx Slot	EDGE [dBm] 1 Tx Slot	EDGE [dBm] 2 Tx Slot	EDGE [dBm] 3 Tx Slot	EDGE [dBm] 4 Tx Slot
GSM 850	128	17.23	18.22	15.71	17.55	17.34	17.83
	190	17.18	18.17	15.67	17.55	17.32	17.81
	251	17.13	17.74	15.61	17.57	17.35	17.76
GSM 1900	512	10.95	10.98	11.03	10.98	10.70	10.91
	661	11.39	11.31	11.50	11.23	10.91	11.18
	810	11.47	11.47	11.65	11.48	11.24	11.37
GSM 850	Frame Avg.Targets:	16.47	17.98	15.47	17.48	17.24	17.49
GSM 1900		10.47	10.98	10.97	10.48	10.24	10.49

Note:

- Both burst-averaged and calculated frame-averaged powers are included. Frame-averaged power was calculated from the measured burst-averaged power by converting the slot powers into linear units and calculating the energy over 8 timeslots.
- The source-based frame-averaged output power was evaluated for all GPRS/EDGE slot configurations. The configuration with the highest target frame averaged output power was evaluated for SAR. When the maximum frame-averaged powers are equivalent across two or more slots (within 0.25 dB), the configuration with the most number of time slots was tested.
- GPRS/EDGE (GMSK) output powers were measured with coding scheme setting of 1 (CS1) on the base station simulator. CS1 was configured to measure GPRS output power measurements and SAR to ensure GMSK modulation in the signal. Our Investigation has shown that CS1 - CS4 settings do not have any impact on the output levels or modulation in the GPRS modes.



FCC ID: ACJ9TGWW13B	 PCTEST ENGINEERING LABORATORY, INC.	SAR EVALUATION REPORT		Reviewed by: Quality Manager
Document S/N: OY1412152300.ACJ	Test Dates: 12/15/14 - 01/08/15	DUT Type: Wireless Module		Page 19 of 91

4. EDGE (8-PSK) output powers were measured with MCS7 on the base station simulator. MCS7 coding scheme was used to measure the output powers for EDGE since investigation has shown that choosing MCS7 coding scheme will ensure 8-PSK modulation. It has been shown that MCS levels that produce 8PSK modulation do not have an impact on output power.

GSM Class: C
GPRS Multislot class: 10
EDGE Multislot class: 12
DTM Multislot Class: N/A



Figure 8-1
Power Measurement Setup

FCC ID: ACJ9TGWW13B		SAR EVALUATION REPORT		Reviewed by: Quality Manager
Document S/N: 0Y1412152300.ACJ	Test Dates: 12/15/14 - 01/08/15	DUT Type: Wireless Module		Page 20 of 91

8.2 UMTS Conducted Powers

Table 8-3
Maximum UMTS Average RF Conducted Powers

3GPP Release Version	Mode	3GPP 34.121 Subtest	Cellular Band [dBm]			AWS Band [dBm]			PCS Band [dBm]			3GPP MPR [dB]
			4132	4183	4233	1312	1412	1862	9262	9400	9538	
99	WCDMA	12.2 kbps RMC	22.44	22.82	22.56	22.84	22.99	22.94	22.97	23.02	23.11	-
6	HSDPA	Subtest 1	21.97	22.14	21.95	21.65	21.88	21.89	21.98	21.92	21.96	0
6		Subtest 2	22.05	22.12	22.08	21.61	21.84	21.88	22.02	21.98	21.94	0
6		Subtest 3	21.57	21.74	21.62	21.21	21.33	21.26	21.40	21.36	21.47	0.5
6		Subtest 4	21.67	21.56	21.72	21.56	21.79	21.76	21.45	21.43	21.52	0.5
6	HSUPA	Subtest 1	21.99	21.78	22.06	22.07	22.16	22.10	21.67	21.81	21.66	0
6		Subtest 2	19.63	20.09	19.89	19.51	19.57	19.62	19.63	19.66	19.57	2
6		Subtest 3	21.04	20.99	21.02	20.75	20.88	20.91	20.84	20.42	20.67	1
6		Subtest 4	19.52	19.87	19.72	19.66	19.59	19.54	19.55	19.51	19.58	2
6		Subtest 5	21.87	21.82	21.95	22.00	22.05	21.98	21.49	21.62	21.58	0
8	DC-HSDPA	Subtest 1	22.03	22.08	21.98	22.41	22.55	22.70	22.21	22.38	22.46	0
8		Subtest 2	21.87	21.95	22.07	22.43	22.49	22.69	22.01	22.26	22.55	0
8		Subtest 3	21.35	21.54	21.45	22.27	22.30	22.21	21.47	21.70	21.91	0.5
8		Subtest 4	21.36	21.47	21.49	22.14	22.21	22.02	21.35	21.68	21.98	0.5

Table 8-4
Reduced UMTS Average RF Conducted Powers

3GPP Release Version	Mode	3GPP 34.121 Subtest	Cellular Band [dBm]			AWS Band [dBm]			PCS Band [dBm]			3GPP MPR [dB]
			4132	4183	4233	1312	1412	1862	9262	9400	9538	
99	WCDMA	12.2 kbps RMC	16.30	16.33	16.43	8.55	8.65	8.30	10.81	10.33	10.79	-
6	HSDPA	Subtest 1	15.59	16.02	16.23	8.35	8.57	8.08	11.00	10.52	11.04	0
6		Subtest 2	15.62	15.97	16.10	8.43	8.51	8.04	10.99	10.57	11.12	0
6		Subtest 3	15.62	15.57	15.69	7.93	8.01	7.43	10.49	10.02	10.57	0.5
6		Subtest 4	15.66	15.52	15.66	7.98	8.00	7.50	10.42	9.98	10.44	0.5
6	HSUPA	Subtest 1	15.52	15.92	15.58	7.79	7.97	7.57	10.59	10.36	10.68	0
6		Subtest 2	14.50	14.82	14.69	7.38	7.30	7.15	8.96	8.83	8.86	2
6		Subtest 3	14.19	14.44	14.25	7.40	7.44	7.29	9.41	9.38	9.33	1
6		Subtest 4	14.48	14.86	14.51	7.22	7.25	7.20	8.82	8.99	8.74	2
6		Subtest 5	15.22	15.38	15.39	7.86	7.89	7.62	10.41	10.47	10.54	0
8	DC-HSDPA	Subtest 1	15.85	15.88	15.83	8.73	8.69	8.54	10.69	10.10	10.86	0
8		Subtest 2	15.71	15.76	15.73	8.72	8.70	8.52	10.84	10.24	10.90	0
8		Subtest 3	14.85	14.88	14.93	8.38	8.29	8.19	10.35	9.77	10.41	0.5
8		Subtest 4	15.37	15.40	15.38	8.43	8.28	8.15	10.34	9.79	10.45	0.5



UMTS SAR was tested under RMC 12.2 kbps with HSPA Inactive per KDB Publication 941225 D01v03. HSPA SAR was not required per KDB Publication 941225 D01v03 per 3G test reduction procedure.

DC-HSDPA considerations

- 3GPP Specification 34.121-1 Release 8 Ver 8.10.0 was used for DC-HSDPA guidance
- H-Set 12 (QPSK) was confirmed to be used during DC-HSDPA measurements
- Measured maximum output powers for DC-HSDPA were not greater than 1/4 dB higher than the WCDMA 12.2 kbps RMC maximum output, as a result, SAR is not required for DC-HSDPA
- The DUT supports UE category 24 for HSDPA



Figure 8-2
Power Measurement Setup

FCC ID: ACJ9TGWW13B	 PCTEST ENGINEERING LABORATORY, INC.	SAR EVALUATION REPORT		Reviewed by: Quality Manager
Document S/N: OY1412152300.ACJ	Test Dates: 12/15/14 - 01/08/15	DUT Type: Wireless Module	Page 21 of 91	

8.3 CDMA Conducted Powers

**Table 8-5
Maximum CDMA Conducted Powers**

Band	Channel	Rule Part	Frequency	TDSO S032 [dBm]	TDSO S032 [dBm]	1x EvDO Rev. 0 [dBm]	1x EvDO Rev. A [dBm]
	F-RC		MHz	FCH+SCH	FCH	(RTAP)	(RETAP)
Cellular	564	90S	820.1	23.63	23.52	23.95	23.92
Cellular	1013	22H	824.7	23.60	23.48	23.78	23.75
	384	22H	836.52	23.61	23.59	23.82	23.80
	777	22H	848.31	23.37	23.33	23.80	23.79
PCS	25	24E	1851.25	24.22	24.29	24.11	24.10
	600	24E	1880	24.18	24.18	23.89	23.88
	1175	24E	1908.75	24.41	24.41	24.09	24.02

**Table 8-6
Reduced CDMA Conducted Powers**

Band	Channel	Rule Part	Frequency	TDSO S032 [dBm]	TDSO S032 [dBm]	1x EvDO Rev. 0 [dBm]	1x EvDO Rev. A [dBm]
	F-RC		MHz	FCH+SCH	FCH	(RTAP)	(RETAP)
Cellular	564	90S	820.1	16.55	16.76	16.78	16.66
Cellular	1013	22H	824.7	16.57	16.86	16.69	16.65
	384	22H	836.52	16.95	16.84	16.98	16.78
	777	22H	848.31	17.01	16.95	17.05	17.00
PCS	25	24E	1851.25	10.27	10.36	10.41	10.05
	600	24E	1880	10.28	10.21	10.38	10.16
	1175	24E	1908.75	10.37	10.34	10.20	10.14

Note:

- For FCC Rule Part 90S, Per FCC KDB Publication 447498 D01v05 4.1.6, only one channel is required since the device operates within the transmission range of 817.90 – 823.10 MHz.

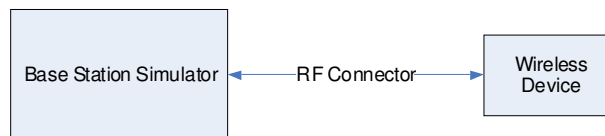

**Figure 8-3
Power Measurement Setup**

FCC ID: ACJ9TGWW13B	PCTEST ENGINEERING LABORATORY, INC.	SAR EVALUATION REPORT		Reviewed by: Quality Manager
Document S/N: OY1412152300.ACJ	Test Dates: 12/15/14 - 01/08/15	DUT Type: Wireless Module		Page 22 of 91

8.4 LTE Conducted Powers

8.4.1 LTE Band 17 Maximum Power

Table 8-7
LTE Band 17 Conducted Powers – 10 MHz Bandwidth



	Frequency [MHz]	Channel	Bandwidth [MHz]	Modulation	RB Size	RB Offset	Conducted Power [dBm]	MPR Allowed per 3GPP [dB]	MPR [dB]
Mid	710.0	23790	10	QPSK	1	0	22.62	0	0
	710.0	23790	10	QPSK	1	25	22.68	0	0
	710.0	23790	10	QPSK	1	49	22.69	0	0
	710.0	23790	10	QPSK	25	0	21.70	0-1	1
	710.0	23790	10	QPSK	25	12	21.72	0-1	1
	710.0	23790	10	QPSK	25	25	21.65	0-1	1
	710.0	23790	10	QPSK	50	0	21.53	0-1	1
	710.0	23790	10	16QAM	1	0	22.22	0-1	1
	710.0	23790	10	16QAM	1	25	22.06	0-1	1
	710.0	23790	10	16QAM	1	49	21.89	0-1	1
	710.0	23790	10	16QAM	25	0	20.64	0-2	2
	710.0	23790	10	16QAM	25	12	20.63	0-2	2
	710.0	23790	10	16QAM	25	25	20.60	0-2	2
710.0	23790	10	16QAM	50	0	20.60	0-2	2	

Note: LTE Band 17 at 10 MHz bandwidth does not support three non-overlapping channels. Per KDB Publication 941225 D05v02, when a device supports overlapping channel assignment in a channel bandwidth configuration, the middle channel of the group of overlapping channels should be selected for testing.

Table 8-8
LTE Band 17 Conducted Powers – 5 MHz Bandwidth

	Frequency [MHz]	Channel	Bandwidth [MHz]	Modulation	RB Size	RB Offset	Conducted Power [dBm]	MPR Allowed per 3GPP [dB]	MPR [dB]
Mid	710.0	23790	5	QPSK	1	0	22.43	0	0
	710.0	23790	5	QPSK	1	12	22.80	0	0
	710.0	23790	5	QPSK	1	24	22.52	0	0
	710.0	23790	5	QPSK	12	0	21.84	0-1	1
	710.0	23790	5	QPSK	12	6	21.67	0-1	1
	710.0	23790	5	QPSK	12	13	21.71	0-1	1
	710.0	23790	5	QPSK	25	0	21.69	0-1	1
	710.0	23790	5	16-QAM	1	0	22.15	0-1	1
	710.0	23790	5	16-QAM	1	12	21.87	0-1	1
	710.0	23790	5	16-QAM	1	24	21.98	0-1	1
	710.0	23790	5	16-QAM	12	0	20.51	0-2	2
	710.0	23790	5	16-QAM	12	6	20.64	0-2	2
	710.0	23790	5	16-QAM	12	13	20.70	0-2	2
	710.0	23790	5	16-QAM	25	0	20.71	0-2	2

Note: LTE Band 17 at 5 MHz bandwidth does not support three non-overlapping channels. Per KDB Publication 941225 D05v02, when a device supports overlapping channel assignment in a channel bandwidth configuration, the middle channel of the group of overlapping channels should be selected for testing.

FCC ID: ACJ9TGWW13B	 PCTEST ENGINEERING LABORATORY, INC.	SAR EVALUATION REPORT		Reviewed by: Quality Manager
Document S/N: OY1412152300.ACJ	Test Dates: 12/15/14 - 01/08/15	DUT Type: Wireless Module		Page 23 of 91

8.4.2 LTE Band 17 Reduced Power

Table 8-9
LTE Band 17 Conducted Powers – 10 MHz Bandwidth



	Frequency [MHz]	Channel	Bandwidth [MHz]	Modulation	RB Size	RB Offset	Conducted Power [dBm]	MPR Allowed per 3GPP [dB]	MPR [dB]
Mid	710.0	23790	10	QPSK	1	0	15.14	0	0
	710.0	23790	10	QPSK	1	25	15.43	0	0
	710.0	23790	10	QPSK	1	49	15.82	0	0
	710.0	23790	10	QPSK	25	0	15.49	0-1	0
	710.0	23790	10	QPSK	25	12	15.47	0-1	0
	710.0	23790	10	QPSK	25	25	15.75	0-1	0
	710.0	23790	10	QPSK	50	0	15.33	0-1	0
	710.0	23790	10	16QAM	1	0	15.86	0-1	0
	710.0	23790	10	16QAM	1	25	15.50	0-1	0
	710.0	23790	10	16QAM	1	49	15.30	0-1	0
	710.0	23790	10	16QAM	25	0	15.57	0-2	0
	710.0	23790	10	16QAM	25	12	15.48	0-2	0
	710.0	23790	10	16QAM	25	25	15.24	0-2	0
	710.0	23790	10	16QAM	50	0	15.39	0-2	0

Note: LTE Band 17 at 10 MHz bandwidth does not support three non-overlapping channels. Per KDB Publication 941225 D05v02, when a device supports overlapping channel assignment in a channel bandwidth configuration, the middle channel of the group of overlapping channels should be selected for testing.

Table 8-10
LTE Band 17 Conducted Powers – 5 MHz Bandwidth

	Frequency [MHz]	Channel	Bandwidth [MHz]	Modulation	RB Size	RB Offset	Conducted Power [dBm]	MPR Allowed per 3GPP [dB]	MPR [dB]
Mid	710.0	23790	5	QPSK	1	0	15.12	0	0
	710.0	23790	5	QPSK	1	12	15.42	0	0
	710.0	23790	5	QPSK	1	24	15.78	0	0
	710.0	23790	5	QPSK	12	0	15.45	0-1	0
	710.0	23790	5	QPSK	12	6	15.46	0-1	0
	710.0	23790	5	QPSK	12	13	15.78	0-1	0
	710.0	23790	5	QPSK	25	0	15.35	0-1	0
	710.0	23790	5	16-QAM	1	0	15.82	0-1	0
	710.0	23790	5	16-QAM	1	12	15.45	0-1	0
	710.0	23790	5	16-QAM	1	24	15.34	0-1	0
	710.0	23790	5	16-QAM	12	0	15.52	0-2	0
	710.0	23790	5	16-QAM	12	6	15.51	0-2	0
	710.0	23790	5	16-QAM	12	13	15.20	0-2	0
	710.0	23790	5	16-QAM	25	0	15.41	0-2	0

Note: LTE Band 17 at 5 MHz bandwidth does not support three non-overlapping channels. Per KDB Publication 941225 D05v02, when a device supports overlapping channel assignment in a channel bandwidth configuration, the middle channel of the group of overlapping channels should be selected for testing.

FCC ID: ACJ9TGWW13B	 PCTEST ENGINEERING LABORATORY, INC.	SAR EVALUATION REPORT		Reviewed by: Quality Manager
Document S/N: OY1412152300.ACJ	Test Dates: 12/15/14 - 01/08/15	DUT Type: Wireless Module		Page 24 of 91

8.4.3 LTE Band 13 Maximum Power



Table 8-11
LTE Band 13 Conducted Powers – 10 MHz Bandwidth

	Frequency [MHz]	Channel	Bandwidth [MHz]	Modulation	RB Size	RB Offset	Conducted Power [dBm]	MPR Allowed per 3GPP [dB]	MPR [dB]
Mid	782.0	23230	10	QPSK	1	0	22.61	0	0
	782.0	23230	10	QPSK	1	25	22.96	0	0
	782.0	23230	10	QPSK	1	49	23.02	0	0
	782.0	23230	10	QPSK	25	0	21.84	0-1	1
	782.0	23230	10	QPSK	25	12	22.00	0-1	1
	782.0	23230	10	QPSK	25	25	21.72	0-1	1
	782.0	23230	10	QPSK	50	0	21.71	0-1	1
	782.0	23230	10	16QAM	1	0	21.93	0-1	1
	782.0	23230	10	16QAM	1	25	22.28	0-1	1
	782.0	23230	10	16QAM	1	49	22.33	0-1	1
	782.0	23230	10	16QAM	25	0	20.56	0-2	2
	782.0	23230	10	16QAM	25	12	20.88	0-2	2
	782.0	23230	10	16QAM	25	25	20.98	0-2	2
	782.0	23230	10	16QAM	50	0	20.69	0-2	2

Table 8-12
LTE Band 13 Conducted Powers – 5 MHz Bandwidth

	Frequency [MHz]	Channel	Bandwidth [MHz]	Modulation	RB Size	RB Offset	Conducted Power [dBm]	MPR Allowed per 3GPP [dB]	MPR [dB]
Mid	782.0	23230	5	QPSK	1	0	22.99	0	0
	782.0	23230	5	QPSK	1	12	23.15	0	0
	782.0	23230	5	QPSK	1	24	23.10	0	0
	782.0	23230	5	QPSK	12	0	21.93	0-1	1
	782.0	23230	5	QPSK	12	6	21.88	0-1	1
	782.0	23230	5	QPSK	12	13	21.89	0-1	1
	782.0	23230	5	QPSK	25	0	21.78	0-1	1
	782.0	23230	5	16-QAM	1	0	21.89	0-1	1
	782.0	23230	5	16-QAM	1	12	22.26	0-1	1
	782.0	23230	5	16-QAM	1	24	22.29	0-1	1
	782.0	23230	5	16-QAM	12	0	21.04	0-2	2
	782.0	23230	5	16-QAM	12	6	21.06	0-2	2
	782.0	23230	5	16-QAM	12	13	21.13	0-2	2
	782.0	23230	5	16-QAM	25	0	20.84	0-2	2

Note: LTE Band 13 at 5 MHz bandwidth does not support three non-overlapping channels. Per KDB Publication 941225 D05v02, when a device supports overlapping channel assignment in a channel bandwidth configuration, the middle channel of the group of overlapping channels should be selected for testing.

FCC ID: ACJ9TGWW13B	 PCTEST ENGINEERING LABORATORY, INC.	SAR EVALUATION REPORT		Reviewed by: Quality Manager
Document S/N: OY1412152300.ACJ	Test Dates: 12/15/14 - 01/08/15	DUT Type: Wireless Module		Page 25 of 91

8.4.4 LTE Band 13 Reduced Power



Table 8-13
LTE Band 13 Conducted Powers – 10 MHz Bandwidth

	Frequency [MHz]	Channel	Bandwidth [MHz]	Modulation	RB Size	RB Offset	Conducted Power [dBm]	MPR Allowed per 3GPP [dB]	MPR [dB]
Mid	782.0	23230	10	QPSK	1	0	15.59	0	0
	782.0	23230	10	QPSK	1	25	15.84	0	0
	782.0	23230	10	QPSK	1	49	15.54	0	0
	782.0	23230	10	QPSK	25	0	15.12	0-1	0
	782.0	23230	10	QPSK	25	12	15.22	0-1	0
	782.0	23230	10	QPSK	25	25	15.15	0-1	0
	782.0	23230	10	QPSK	50	0	15.21	0-1	0
	782.0	23230	10	16QAM	1	0	15.63	0-1	0
	782.0	23230	10	16QAM	1	25	15.37	0-1	0
	782.0	23230	10	16QAM	1	49	15.35	0-1	0
	782.0	23230	10	16QAM	25	0	15.55	0-2	0
	782.0	23230	10	16QAM	25	12	15.61	0-2	0
	782.0	23230	10	16QAM	25	25	15.34	0-2	0
	782.0	23230	10	16QAM	50	0	15.19	0-2	0

Table 8-14
LTE Band 13 Conducted Powers – 5 MHz Bandwidth

	Frequency [MHz]	Channel	Bandwidth [MHz]	Modulation	RB Size	RB Offset	Conducted Power [dBm]	MPR Allowed per 3GPP [dB]	MPR [dB]
Mid	782.0	23230	5	QPSK	1	0	15.59	0	0
	782.0	23230	5	QPSK	1	12	15.87	0	0
	782.0	23230	5	QPSK	1	24	15.49	0	0
	782.0	23230	5	QPSK	12	0	15.18	0-1	0
	782.0	23230	5	QPSK	12	6	15.27	0-1	0
	782.0	23230	5	QPSK	12	13	15.28	0-1	0
	782.0	23230	5	QPSK	25	0	15.23	0-1	0
	782.0	23230	5	16-QAM	1	0	15.64	0-1	0
	782.0	23230	5	16-QAM	1	12	15.41	0-1	0
	782.0	23230	5	16-QAM	1	24	15.38	0-1	0
	782.0	23230	5	16-QAM	12	0	15.60	0-2	0
	782.0	23230	5	16-QAM	12	6	15.63	0-2	0
	782.0	23230	5	16-QAM	12	13	15.35	0-2	0
	782.0	23230	5	16-QAM	25	0	15.19	0-2	0

Note: LTE Band 13 at 5 MHz bandwidth does not support three non-overlapping channels. Per KDB Publication 941225 D05v02, when a device supports overlapping channel assignment in a channel bandwidth configuration, the middle channel of the group of overlapping channels should be selected for testing.

FCC ID: ACJ9TGWW13B		SAR EVALUATION REPORT		Reviewed by: Quality Manager
Document S/N: OY1412152300.ACJ	Test Dates: 12/15/14 - 01/08/15	DUT Type: Wireless Module	Page 26 of 91	

8.4.5 LTE Band 5 (Cell) Maximum Power

Table 8-15
LTE Band 5 (Cell) Conducted Powers – 10 MHz Bandwidth

	Frequency [MHz]	Channel	Bandwidth [MHz]	Modulation	RB Size	RB Offset	Conducted Power [dBm]	MPR Allowed per 3GPP [dB]	MPR [dB]
Mid	836.5	20525	10	QPSK	1	0	22.59	0	0
	836.5	20525	10	QPSK	1	25	22.54	0	0
	836.5	20525	10	QPSK	1	49	22.54	0	0
	836.5	20525	10	QPSK	25	0	21.57	0-1	1
	836.5	20525	10	QPSK	25	12	21.61	0-1	1
	836.5	20525	10	QPSK	25	25	21.59	0-1	1
	836.5	20525	10	QPSK	50	0	21.56	0-1	1
	836.5	20525	10	16QAM	1	0	21.50	0-1	1
	836.5	20525	10	16QAM	1	25	21.52	0-1	1
	836.5	20525	10	16QAM	1	49	21.65	0-1	1
	836.5	20525	10	16QAM	25	0	20.57	0-2	2
	836.5	20525	10	16QAM	25	12	20.63	0-2	2
	836.5	20525	10	16QAM	25	25	20.65	0-2	2
	836.5	20525	10	16QAM	50	0	20.55	0-2	2

Note: LTE Band 5 at 10 MHz bandwidth does not support three non-overlapping channels. Per KDB Publication 941225 D05v02, when a device supports overlapping channel assignment in a channel bandwidth configuration, the middle channel of the group of overlapping channels should be selected for testing.



FCC ID: ACJ9TGWW13B	 PCTEST ENGINEERING LABORATORY, INC.	SAR EVALUATION REPORT		Reviewed by: Quality Manager
Document S/N: OY1412152300.ACJ	Test Dates: 12/15/14 - 01/08/15	DUT Type: Wireless Module		Page 27 of 91

Table 8-16
LTE Band 5 (Cell) Conducted Powers – 5 MHz Bandwidth

	Frequency [MHz]	Channel	Bandwidth [MHz]	Modulation	RB Size	RB Offset	Conducted Power [dBm]	MPR Allowed per 3GPP [dB]	MPR [dB]
Low	826.5	20425	5	QPSK	1	0	22.15	0	0
	826.5	20425	5	QPSK	1	12	22.39	0	0
	826.5	20425	5	QPSK	1	24	22.19	0	0
	826.5	20425	5	QPSK	12	0	21.25	0-1	1
	826.5	20425	5	QPSK	12	6	21.40	0-1	1
	826.5	20425	5	QPSK	12	13	21.28	0-1	1
	826.5	20425	5	QPSK	25	0	21.12	0-1	1
	826.5	20425	5	16-QAM	1	0	21.28	0-1	1
	826.5	20425	5	16-QAM	1	12	21.74	0-1	1
	826.5	20425	5	16-QAM	1	24	21.05	0-1	1
	826.5	20425	5	16-QAM	12	0	20.26	0-2	2
	826.5	20425	5	16-QAM	12	6	20.58	0-2	2
826.5	20425	5	16-QAM	12	13	20.33	0-2	2	
826.5	20425	5	16-QAM	25	0	20.23	0-2	2	
Mid	836.5	20525	5	QPSK	1	0	22.40	0	0
	836.5	20525	5	QPSK	1	12	22.52	0	0
	836.5	20525	5	QPSK	1	24	22.23	0	0
	836.5	20525	5	QPSK	12	0	21.44	0-1	1
	836.5	20525	5	QPSK	12	6	21.31	0-1	1
	836.5	20525	5	QPSK	12	13	21.22	0-1	1
	836.5	20525	5	QPSK	25	0	21.25	0-1	1
	836.5	20525	5	16-QAM	1	0	21.03	0-1	1
	836.5	20525	5	16-QAM	1	12	21.37	0-1	1
	836.5	20525	5	16-QAM	1	24	21.38	0-1	1
	836.5	20525	5	16-QAM	12	0	20.59	0-2	2
	836.5	20525	5	16-QAM	12	6	20.56	0-2	2
836.5	20525	5	16-QAM	12	13	20.37	0-2	2	
836.5	20525	5	16-QAM	25	0	20.51	0-2	2	
High	846.5	20625	5	QPSK	1	0	22.26	0	0
	846.5	20625	5	QPSK	1	12	22.30	0	0
	846.5	20625	5	QPSK	1	24	22.65	0	0
	846.5	20625	5	QPSK	12	0	21.43	0-1	1
	846.5	20625	5	QPSK	12	6	21.28	0-1	1
	846.5	20625	5	QPSK	12	13	21.30	0-1	1
	846.5	20625	5	QPSK	25	0	21.08	0-1	1
	846.5	20625	5	16-QAM	1	0	21.50	0-1	1
	846.5	20625	5	16-QAM	1	12	21.46	0-1	1
	846.5	20625	5	16-QAM	1	24	21.16	0-1	1
	846.5	20625	5	16-QAM	12	0	20.23	0-2	2
	846.5	20625	5	16-QAM	12	6	20.45	0-2	2
846.5	20625	5	16-QAM	12	13	20.48	0-2	2	
846.5	20625	5	16-QAM	25	0	20.32	0-2	2	



FCC ID: ACJ9TGWW13B	 PCTEST ENGINEERING LABORATORY, INC.	SAR EVALUATION REPORT		Reviewed by: Quality Manager
Document S/N: OY1412152300.ACJ	Test Dates: 12/15/14 - 01/08/15	DUT Type: Wireless Module	Page 28 of 91	

Table 8-17
LTE Band 5 (Cell) Conducted Powers – 3 MHz Bandwidth

	Frequency [MHz]	Channel	Bandwidth [MHz]	Modulation	RB Size	RB Offset	Conducted Power [dBm]	MPR Allowed per 3GPP [dB]	MPR [dB]
Low	825.5	20415	3	QPSK	1	0	22.37	0	0
	825.5	20415	3	QPSK	1	7	22.46	0	0
	825.5	20415	3	QPSK	1	14	22.19	0	0
	825.5	20415	3	QPSK	8	0	21.21	0-1	1
	825.5	20415	3	QPSK	8	4	21.36	0-1	1
	825.5	20415	3	QPSK	8	7	21.19	0-1	1
	825.5	20415	3	QPSK	15	0	21.24	0-1	1
	825.5	20415	3	16-QAM	1	0	21.34	0-1	1
	825.5	20415	3	16-QAM	1	7	21.71	0-1	1
	825.5	20415	3	16-QAM	1	14	21.29	0-1	1
	825.5	20415	3	16-QAM	8	0	20.42	0-2	2
	825.5	20415	3	16-QAM	8	4	20.70	0-2	2
Mid	836.5	20525	3	QPSK	1	0	22.32	0	0
	836.5	20525	3	QPSK	1	7	22.43	0	0
	836.5	20525	3	QPSK	1	14	22.26	0	0
	836.5	20525	3	QPSK	8	0	21.71	0-1	1
	836.5	20525	3	QPSK	8	4	21.30	0-1	1
	836.5	20525	3	QPSK	8	7	21.40	0-1	1
	836.5	20525	3	QPSK	15	0	21.35	0-1	1
	836.5	20525	3	16-QAM	1	0	21.08	0-1	1
	836.5	20525	3	16-QAM	1	7	21.54	0-1	1
	836.5	20525	3	16-QAM	1	14	21.49	0-1	1
	836.5	20525	3	16-QAM	8	0	20.73	0-2	2
	836.5	20525	3	16-QAM	8	4	20.62	0-2	2
High	847.5	20635	3	QPSK	1	0	22.53	0	0
	847.5	20635	3	QPSK	1	7	22.57	0	0
	847.5	20635	3	QPSK	1	14	22.91	0	0
	847.5	20635	3	QPSK	8	0	21.64	0-1	1
	847.5	20635	3	QPSK	8	4	21.33	0-1	1
	847.5	20635	3	QPSK	8	7	21.56	0-1	1
	847.5	20635	3	QPSK	15	0	21.05	0-1	1
	847.5	20635	3	16-QAM	1	0	21.76	0-1	1
	847.5	20635	3	16-QAM	1	7	21.51	0-1	1
	847.5	20635	3	16-QAM	1	14	21.28	0-1	1
	847.5	20635	3	16-QAM	8	0	20.17	0-2	2
	847.5	20635	3	16-QAM	8	4	20.59	0-2	2
847.5	20635	3	16-QAM	8	7	20.78	0-2	2	
847.5	20635	3	16-QAM	15	0	20.29	0-2	2	





FCC ID: ACJ9TGWW13B	 PCTEST ENGINEERING LABORATORY, INC.	SAR EVALUATION REPORT		Reviewed by: Quality Manager
Document S/N: OY1412152300.ACJ	Test Dates: 12/15/14 - 01/08/15	DUT Type: Wireless Module	Page 29 of 91	

Table 8-18
LTE Band 5 (Cell) Conducted Powers – 1.4 MHz Bandwidth

	Frequency [MHz]	Channel	Bandwidth [MHz]	Modulation	RB Size	RB Offset	Conducted Power [dBm]	MPR Allowed per 3GPP [dB]	MPR [dB]
Low	824.7	20407	1.4	QPSK	1	0	22.38	0	0
	824.7	20407	1.4	QPSK	1	2	22.57	0	0
	824.7	20407	1.4	QPSK	1	5	22.25	0	0
	824.7	20407	1.4	QPSK	3	0	22.29	0	0
	824.7	20407	1.4	QPSK	3	2	22.32	0	0
	824.7	20407	1.4	QPSK	3	3	22.10	0	0
	824.7	20407	1.4	QPSK	6	0	21.07	0-1	1
	824.7	20407	1.4	16-QAM	1	0	21.48	0-1	1
	824.7	20407	1.4	16-QAM	1	2	21.87	0-1	1
	824.7	20407	1.4	16-QAM	1	5	21.17	0-1	1
	824.7	20407	1.4	16-QAM	3	0	21.40	0-1	1
	824.7	20407	1.4	16-QAM	3	2	21.51	0-1	1
824.7	20407	1.4	16-QAM	3	3	21.49	0-1	1	
824.7	20407	1.4	16-QAM	6	0	20.24	0-2	2	
Mid	836.5	20525	1.4	QPSK	1	0	22.40	0	0
	836.5	20525	1.4	QPSK	1	2	22.48	0	0
	836.5	20525	1.4	QPSK	1	5	22.46	0	0
	836.5	20525	1.4	QPSK	3	0	22.73	0	0
	836.5	20525	1.4	QPSK	3	2	22.49	0	0
	836.5	20525	1.4	QPSK	3	3	22.58	0	0
	836.5	20525	1.4	QPSK	6	0	21.43	0-1	1
	836.5	20525	1.4	16-QAM	1	0	21.11	0-1	1
	836.5	20525	1.4	16-QAM	1	2	21.60	0-1	1
	836.5	20525	1.4	16-QAM	1	5	21.32	0-1	1
	836.5	20525	1.4	16-QAM	3	0	21.55	0-1	1
	836.5	20525	1.4	16-QAM	3	2	21.47	0-1	1
836.5	20525	1.4	16-QAM	3	3	21.31	0-1	1	
836.5	20525	1.4	16-QAM	6	0	20.33	0-2	2	
High	848.3	20643	1.4	QPSK	1	0	22.49	0	0
	848.3	20643	1.4	QPSK	1	2	22.70	0	0
	848.3	20643	1.4	QPSK	1	5	22.89	0	0
	848.3	20643	1.4	QPSK	3	0	22.71	0	0
	848.3	20643	1.4	QPSK	3	2	22.33	0	0
	848.3	20643	1.4	QPSK	3	3	22.71	0	0
	848.3	20643	1.4	QPSK	6	0	21.10	0-1	1
	848.3	20643	1.4	16-QAM	1	0	21.83	0-1	1
	848.3	20643	1.4	16-QAM	1	2	21.58	0-1	1
	848.3	20643	1.4	16-QAM	1	5	21.10	0-1	1
	848.3	20643	1.4	16-QAM	3	0	21.25	0-1	1
	848.3	20643	1.4	16-QAM	3	2	21.59	0-1	1
848.3	20643	1.4	16-QAM	3	3	21.73	0-1	1	
848.3	20643	1.4	16-QAM	6	0	20.31	0-2	2	



FCC ID: ACJ9TGWW13B	 PCTEST ENGINEERING LABORATORY, INC.	SAR EVALUATION REPORT		Reviewed by: Quality Manager
Document S/N: OY1412152300.ACJ	Test Dates: 12/15/14 - 01/08/15	DUT Type: Wireless Module	Page 30 of 91	

8.4.6 LTE Band 5 (Cell) Reduced Power

Table 8-19
LTE Band 5 (Cell) Conducted Powers – 10 MHz Bandwidth



	Frequency [MHz]	Channel	Bandwidth [MHz]	Modulation	RB Size	RB Offset	Conducted Power [dBm]	MPR Allowed per 3GPP [dB]	MPR [dB]
Mid	836.5	20525	10	QPSK	1	0	15.71	0	0
	836.5	20525	10	QPSK	1	25	15.88	0	0
	836.5	20525	10	QPSK	1	49	15.19	0	0
	836.5	20525	10	QPSK	25	0	15.70	0-1	0
	836.5	20525	10	QPSK	25	12	15.71	0-1	0
	836.5	20525	10	QPSK	25	25	15.68	0-1	0
	836.5	20525	10	QPSK	50	0	15.62	0-1	0
	836.5	20525	10	16QAM	1	0	15.41	0-1	0
	836.5	20525	10	16QAM	1	25	15.90	0-1	0
	836.5	20525	10	16QAM	1	49	15.39	0-1	0
	836.5	20525	10	16QAM	25	0	15.81	0-2	0
	836.5	20525	10	16QAM	25	12	15.64	0-2	0
	836.5	20525	10	16QAM	25	25	15.72	0-2	0
	836.5	20525	10	16QAM	50	0	15.75	0-2	0

Note: LTE Band 5 at 10 MHz bandwidth does not support three non-overlapping channels. Per KDB Publication 941225 D05v02, when a device supports overlapping channel assignment in a channel bandwidth configuration, the middle channel of the group of overlapping channels should be selected for testing.

FCC ID: ACJ9TGWW13B	 PCTEST ENGINEERING LABORATORY, INC.	SAR EVALUATION REPORT		Reviewed by: Quality Manager
Document S/N: OY1412152300.ACJ	Test Dates: 12/15/14 - 01/08/15	DUT Type: Wireless Module	Page 31 of 91	

**Table 8-20
LTE Band 5 (Cell) Conducted Powers – 5 MHz Bandwidth**

	Frequency [MHz]	Channel	Bandwidth [MHz]	Modulation	RB Size	RB Offset	Conducted Power [dBm]	MPR Allowed per 3GPP [dB]	MPR [dB]
Low	826.5	20425	5	QPSK	1	0	15.89	0	0
	826.5	20425	5	QPSK	1	12	15.91	0	0
	826.5	20425	5	QPSK	1	24	15.80	0	0
	826.5	20425	5	QPSK	12	0	15.87	0-1	0
	826.5	20425	5	QPSK	12	6	15.86	0-1	0
	826.5	20425	5	QPSK	12	13	15.91	0-1	0
	826.5	20425	5	QPSK	25	0	15.82	0-1	0
	826.5	20425	5	16-QAM	1	0	15.90	0-1	0
	826.5	20425	5	16-QAM	1	12	15.92	0-1	0
	826.5	20425	5	16-QAM	1	24	15.82	0-1	0
	826.5	20425	5	16-QAM	12	0	15.87	0-2	0
	826.5	20425	5	16-QAM	12	6	15.90	0-2	0
826.5	20425	5	16-QAM	12	13	15.92	0-2	0	
826.5	20425	5	16-QAM	25	0	15.89	0-2	0	
Mid	836.5	20525	5	QPSK	1	0	15.52	0	0
	836.5	20525	5	QPSK	1	12	15.50	0	0
	836.5	20525	5	QPSK	1	24	15.36	0	0
	836.5	20525	5	QPSK	12	0	15.76	0-1	0
	836.5	20525	5	QPSK	12	6	15.93	0-1	0
	836.5	20525	5	QPSK	12	13	15.68	0-1	0
	836.5	20525	5	QPSK	25	0	15.70	0-1	0
	836.5	20525	5	16-QAM	1	0	15.80	0-1	0
	836.5	20525	5	16-QAM	1	12	15.76	0-1	0
	836.5	20525	5	16-QAM	1	24	15.83	0-1	0
	836.5	20525	5	16-QAM	12	0	15.70	0-2	0
	836.5	20525	5	16-QAM	12	6	15.62	0-2	0
836.5	20525	5	16-QAM	12	13	15.66	0-2	0	
836.5	20525	5	16-QAM	25	0	15.71	0-2	0	
High	846.5	20625	5	QPSK	1	0	15.64	0	0
	846.5	20625	5	QPSK	1	12	15.94	0	0
	846.5	20625	5	QPSK	1	24	15.89	0	0
	846.5	20625	5	QPSK	12	0	15.86	0-1	0
	846.5	20625	5	QPSK	12	6	15.81	0-1	0
	846.5	20625	5	QPSK	12	13	15.93	0-1	0
	846.5	20625	5	QPSK	25	0	15.79	0-1	0
	846.5	20625	5	16-QAM	1	0	15.91	0-1	0
	846.5	20625	5	16-QAM	1	12	15.80	0-1	0
	846.5	20625	5	16-QAM	1	24	15.95	0-1	0
	846.5	20625	5	16-QAM	12	0	15.95	0-2	0
	846.5	20625	5	16-QAM	12	6	15.82	0-2	0
846.5	20625	5	16-QAM	12	13	15.76	0-2	0	
846.5	20625	5	16-QAM	25	0	15.83	0-2	0	

FCC ID: ACJ9TGWW13B	 PCTEST ENGINEERING LABORATORY, INC.	SAR EVALUATION REPORT		Reviewed by: Quality Manager
Document S/N: OY1412152300.ACJ	Test Dates: 12/15/14 - 01/08/15	DUT Type: Wireless Module	Page 32 of 91	

**Table 8-21
LTE Band 5 (Cell) Conducted Powers – 3 MHz Bandwidth**

	Frequency [MHz]	Channel	Bandwidth [MHz]	Modulation	RB Size	RB Offset	Conducted Power [dBm]	MPR Allowed per 3GPP [dB]	MPR [dB]
Low	825.5	20415	3	QPSK	1	0	15.85	0	0
	825.5	20415	3	QPSK	1	7	15.96	0	0
	825.5	20415	3	QPSK	1	14	15.81	0	0
	825.5	20415	3	QPSK	8	0	15.91	0-1	0
	825.5	20415	3	QPSK	8	4	15.87	0-1	0
	825.5	20415	3	QPSK	8	7	15.89	0-1	0
	825.5	20415	3	QPSK	15	0	15.79	0-1	0
	825.5	20415	3	16-QAM	1	0	15.93	0-1	0
	825.5	20415	3	16-QAM	1	7	15.92	0-1	0
	825.5	20415	3	16-QAM	1	14	15.81	0-1	0
	825.5	20415	3	16-QAM	8	0	15.91	0-2	0
	825.5	20415	3	16-QAM	8	4	15.89	0-2	0
825.5	20415	3	16-QAM	8	7	15.95	0-2	0	
825.5	20415	3	16-QAM	15	0	15.85	0-2	0	
Mid	836.5	20525	3	QPSK	1	0	15.52	0	0
	836.5	20525	3	QPSK	1	7	15.53	0	0
	836.5	20525	3	QPSK	1	14	15.31	0	0
	836.5	20525	3	QPSK	8	0	15.81	0-1	0
	836.5	20525	3	QPSK	8	4	15.93	0-1	0
	836.5	20525	3	QPSK	8	7	15.65	0-1	0
	836.5	20525	3	QPSK	15	0	15.73	0-1	0
	836.5	20525	3	16-QAM	1	0	15.77	0-1	0
	836.5	20525	3	16-QAM	1	7	15.80	0-1	0
	836.5	20525	3	16-QAM	1	14	15.79	0-1	0
	836.5	20525	3	16-QAM	8	0	15.71	0-2	0
	836.5	20525	3	16-QAM	8	4	15.62	0-2	0
836.5	20525	3	16-QAM	8	7	15.61	0-2	0	
836.5	20525	3	16-QAM	15	0	15.67	0-2	0	
High	847.5	20635	3	QPSK	1	0	15.63	0	0
	847.5	20635	3	QPSK	1	7	15.93	0	0
	847.5	20635	3	QPSK	1	14	15.86	0	0
	847.5	20635	3	QPSK	8	0	15.89	0-1	0
	847.5	20635	3	QPSK	8	4	15.79	0-1	0
	847.5	20635	3	QPSK	8	7	15.97	0-1	0
	847.5	20635	3	QPSK	15	0	15.82	0-1	0
	847.5	20635	3	16-QAM	1	0	15.92	0-1	0
	847.5	20635	3	16-QAM	1	7	15.84	0-1	0
	847.5	20635	3	16-QAM	1	14	15.99	0-1	0
	847.5	20635	3	16-QAM	8	0	15.91	0-2	0
	847.5	20635	3	16-QAM	8	4	15.83	0-2	0
847.5	20635	3	16-QAM	8	7	15.74	0-2	0	
847.5	20635	3	16-QAM	15	0	15.84	0-2	0	





FCC ID: ACJ9TGWW13B	 PCTEST ENGINEERING LABORATORY, INC.	SAR EVALUATION REPORT		Reviewed by: Quality Manager
Document S/N: OY1412152300.ACJ	Test Dates: 12/15/14 - 01/08/15	DUT Type: Wireless Module	Page 33 of 91	

Table 8-22
LTE Band 5 (Cell) Conducted Powers – 1.4 MHz Bandwidth

	Frequency [MHz]	Channel	Bandwidth [MHz]	Modulation	RB Size	RB Offset	Conducted Power [dBm]	MPR Allowed per 3GPP [dB]	MPR [dB]
Low	824.7	20407	1.4	QPSK	1	0	15.81	0	0
	824.7	20407	1.4	QPSK	1	2	15.92	0	0
	824.7	20407	1.4	QPSK	1	5	15.85	0	0
	824.7	20407	1.4	QPSK	3	0	15.94	0	0
	824.7	20407	1.4	QPSK	3	2	15.84	0	0
	824.7	20407	1.4	QPSK	3	3	15.92	0	0
	824.7	20407	1.4	QPSK	6	0	15.78	0-1	0
	824.7	20407	1.4	16-QAM	1	0	15.92	0-1	0
	824.7	20407	1.4	16-QAM	1	2	15.91	0-1	0
	824.7	20407	1.4	16-QAM	1	5	15.86	0-1	0
	824.7	20407	1.4	16-QAM	3	0	15.88	0-1	0
	824.7	20407	1.4	16-QAM	3	2	15.92	0-1	0
Mid	824.7	20407	1.4	16-QAM	3	3	15.92	0-1	0
	824.7	20407	1.4	16-QAM	6	0	15.89	0-2	0
	836.5	20525	1.4	QPSK	1	0	15.52	0	0
	836.5	20525	1.4	QPSK	1	2	15.50	0	0
	836.5	20525	1.4	QPSK	1	5	15.33	0	0
	836.5	20525	1.4	QPSK	3	0	15.84	0	0
	836.5	20525	1.4	QPSK	3	2	15.96	0	0
	836.5	20525	1.4	QPSK	3	3	15.66	0	0
	836.5	20525	1.4	QPSK	6	0	15.68	0-1	0
	836.5	20525	1.4	16-QAM	1	0	15.79	0-1	0
	836.5	20525	1.4	16-QAM	1	2	15.84	0-1	0
	836.5	20525	1.4	16-QAM	1	5	15.75	0-1	0
High	836.5	20525	1.4	16-QAM	3	0	15.72	0-1	0
	836.5	20525	1.4	16-QAM	3	2	15.61	0-1	0
	836.5	20525	1.4	16-QAM	3	3	15.66	0-1	0
	836.5	20525	1.4	16-QAM	6	0	15.70	0-2	0
	848.3	20643	1.4	QPSK	1	0	15.64	0	0
	848.3	20643	1.4	QPSK	1	2	15.89	0	0
	848.3	20643	1.4	QPSK	1	5	15.85	0	0
	848.3	20643	1.4	QPSK	3	0	15.84	0	0
	848.3	20643	1.4	QPSK	3	2	15.75	0	0
	848.3	20643	1.4	QPSK	3	3	16.02	0	0
	848.3	20643	1.4	QPSK	6	0	15.82	0-1	0
	848.3	20643	1.4	16-QAM	1	0	15.87	0-1	0
848.3	20643	1.4	16-QAM	1	2	15.79	0-1	0	
848.3	20643	1.4	16-QAM	1	5	16.01	0-1	0	
848.3	20643	1.4	16-QAM	3	0	15.95	0-1	0	
848.3	20643	1.4	16-QAM	3	2	15.79	0-1	0	
848.3	20643	1.4	16-QAM	3	3	15.70	0-1	0	
848.3	20643	1.4	16-QAM	6	0	15.87	0-2	0	



FCC ID: ACJ9TGWW13B	 PCTEST ENGINEERING LABORATORY, INC.	SAR EVALUATION REPORT		Reviewed by: Quality Manager
Document S/N: OY1412152300.ACJ	Test Dates: 12/15/14 - 01/08/15	DUT Type: Wireless Module		Page 34 of 91

8.4.7 LTE Band 4 (AWS) Maximum Power

Table 8-23
LTE Band 4 (AWS) Conducted Powers – 20 MHz Bandwidth



	Frequency [MHz]	Channel	Bandwidth [MHz]	Modulation	RB Size	RB Offset	Conducted Power [dBm]	MPR Allowed per 3GPP [dB]	MPR [dB]
Mid	1732.5	20175	20	QPSK	1	0	22.89	0	0
	1732.5	20175	20	QPSK	1	50	22.84	0	0
	1732.5	20175	20	QPSK	1	99	22.93	0	0
	1732.5	20175	20	QPSK	50	0	21.64	0-1	1
	1732.5	20175	20	QPSK	50	25	21.60	0-1	1
	1732.5	20175	20	QPSK	50	50	21.55	0-1	1
	1732.5	20175	20	QPSK	100	0	21.63	0-1	1
	1732.5	20175	20	16QAM	1	0	21.81	0-1	1
	1732.5	20175	20	16QAM	1	50	21.87	0-1	1
	1732.5	20175	20	16QAM	1	99	22.05	0-1	1
	1732.5	20175	20	16QAM	50	0	20.66	0-2	2
	1732.5	20175	20	16QAM	50	25	20.68	0-2	2
	1732.5	20175	20	16QAM	50	50	20.58	0-2	2
	1732.5	20175	20	16QAM	100	0	20.64	0-2	2

Note: LTE Band 4 at 20 MHz bandwidth does not support three non-overlapping channels. Per KDB Publication 941225 D05v02, when a device supports overlapping channel assignment in a channel bandwidth configuration, the middle channel of the group of overlapping channels should be selected for testing.

FCC ID: ACJ9TGWW13B	 PCTEST ENGINEERING LABORATORY, INC.	SAR EVALUATION REPORT		Reviewed by: Quality Manager
Document S/N: OY1412152300.ACJ	Test Dates: 12/15/14 - 01/08/15	DUT Type: Wireless Module		Page 35 of 91

**Table 8-24
LTE Band 4 (AWS) Conducted Powers – 15 MHz Bandwidth**

	Frequency [MHz]	Channel	Bandwidth [MHz]	Modulation	RB Size	RB Offset	Conducted Power [dBm]	MPR Allowed per 3GPP [dB]	MPR [dB]
Low	1717.5	20025	15	QPSK	1	0	22.75	0	0
	1717.5	20025	15	QPSK	1	36	22.86	0	0
	1717.5	20025	15	QPSK	1	74	22.95	0	0
	1717.5	20025	15	QPSK	36	0	21.58	0-1	1
	1717.5	20025	15	QPSK	36	18	21.60	0-1	1
	1717.5	20025	15	QPSK	36	37	21.63	0-1	1
	1717.5	20025	15	QPSK	75	0	21.51	0-1	1
	1717.5	20025	15	16QAM	1	0	21.64	0-1	1
	1717.5	20025	15	16QAM	1	36	21.59	0-1	1
	1717.5	20025	15	16QAM	1	74	21.80	0-1	1
	1717.5	20025	15	16QAM	36	0	20.52	0-2	2
	1717.5	20025	15	16QAM	36	18	20.52	0-2	2
1717.5	20025	15	16QAM	36	37	20.61	0-2	2	
1717.5	20025	15	16QAM	75	0	20.53	0-2	2	
Mid	1732.5	20175	15	QPSK	1	0	22.79	0	0
	1732.5	20175	15	QPSK	1	36	22.92	0	0
	1732.5	20175	15	QPSK	1	74	22.90	0	0
	1732.5	20175	15	QPSK	36	0	21.65	0-1	1
	1732.5	20175	15	QPSK	36	18	21.67	0-1	1
	1732.5	20175	15	QPSK	36	37	21.61	0-1	1
	1732.5	20175	15	QPSK	75	0	21.64	0-1	1
	1732.5	20175	15	16QAM	1	0	22.19	0-1	1
	1732.5	20175	15	16QAM	1	36	22.21	0-1	1
	1732.5	20175	15	16QAM	1	74	22.17	0-1	1
	1732.5	20175	15	16QAM	36	0	20.69	0-2	2
	1732.5	20175	15	16QAM	36	18	20.78	0-2	2
1732.5	20175	15	16QAM	36	37	20.73	0-2	2	
1732.5	20175	15	16QAM	75	0	20.58	0-2	2	
High	1747.5	20325	15	QPSK	1	0	22.86	0	0
	1747.5	20325	15	QPSK	1	36	22.68	0	0
	1747.5	20325	15	QPSK	1	74	22.78	0	0
	1747.5	20325	15	QPSK	36	0	21.65	0-1	1
	1747.5	20325	15	QPSK	36	18	21.64	0-1	1
	1747.5	20325	15	QPSK	36	37	21.65	0-1	1
	1747.5	20325	15	QPSK	75	0	21.56	0-1	1
	1747.5	20325	15	16QAM	1	0	22.03	0-1	1
	1747.5	20325	15	16QAM	1	36	21.90	0-1	1
	1747.5	20325	15	16QAM	1	74	22.01	0-1	1
	1747.5	20325	15	16QAM	36	0	20.58	0-2	2
	1747.5	20325	15	16QAM	36	18	20.65	0-2	2
1747.5	20325	15	16QAM	36	37	20.94	0-2	2	
1747.5	20325	15	16QAM	75	0	20.50	0-2	2	

FCC ID: ACJ9TGWW13B	 PCTEST ENGINEERING LABORATORY, INC.	SAR EVALUATION REPORT		Reviewed by: Quality Manager
Document S/N: OY1412152300.ACJ	Test Dates: 12/15/14 - 01/08/15	DUT Type: Wireless Module		Page 36 of 91

**Table 8-25
LTE Band 4 (AWS) Conducted Powers – 10 MHz Bandwidth**

	Frequency [MHz]	Channel	Bandwidth [MHz]	Modulation	RB Size	RB Offset	Conducted Power [dBm]	MPR Allowed per 3GPP [dB]	MPR [dB]
Low	1715	20000	10	QPSK	1	0	22.81	0	0
	1715	20000	10	QPSK	1	25	22.87	0	0
	1715	20000	10	QPSK	1	49	22.86	0	0
	1715	20000	10	QPSK	25	0	21.63	0-1	1
	1715	20000	10	QPSK	25	12	21.72	0-1	1
	1715	20000	10	QPSK	25	25	21.67	0-1	1
	1715	20000	10	QPSK	50	0	21.59	0-1	1
	1715	20000	10	16QAM	1	0	21.65	0-1	1
	1715	20000	10	16QAM	1	25	21.64	0-1	1
	1715	20000	10	16QAM	1	49	21.73	0-1	1
	1715	20000	10	16QAM	25	0	20.64	0-2	2
	1715	20000	10	16QAM	25	12	20.69	0-2	2
1715	20000	10	16QAM	25	25	20.60	0-2	2	
1715	20000	10	16QAM	50	0	20.51	0-2	2	
Mid	1732.5	20175	10	QPSK	1	0	22.89	0	0
	1732.5	20175	10	QPSK	1	25	22.89	0	0
	1732.5	20175	10	QPSK	1	49	22.93	0	0
	1732.5	20175	10	QPSK	25	0	21.85	0-1	1
	1732.5	20175	10	QPSK	25	12	21.76	0-1	1
	1732.5	20175	10	QPSK	25	25	21.82	0-1	1
	1732.5	20175	10	QPSK	50	0	21.66	0-1	1
	1732.5	20175	10	16QAM	1	0	22.46	0-1	1
	1732.5	20175	10	16QAM	1	25	22.49	0-1	1
	1732.5	20175	10	16QAM	1	49	22.48	0-1	1
	1732.5	20175	10	16QAM	25	0	20.73	0-2	2
	1732.5	20175	10	16QAM	25	12	20.84	0-2	2
1732.5	20175	10	16QAM	25	25	20.83	0-2	2	
1732.5	20175	10	16QAM	50	0	20.69	0-2	2	
High	1750	20350	10	QPSK	1	0	22.76	0	0
	1750	20350	10	QPSK	1	25	22.85	0	0
	1750	20350	10	QPSK	1	49	22.68	0	0
	1750	20350	10	QPSK	25	0	21.64	0-1	1
	1750	20350	10	QPSK	25	12	21.60	0-1	1
	1750	20350	10	QPSK	25	25	21.91	0-1	1
	1750	20350	10	QPSK	50	0	21.70	0-1	1
	1750	20350	10	16QAM	1	0	21.63	0-1	1
	1750	20350	10	16QAM	1	25	21.70	0-1	1
	1750	20350	10	16QAM	1	49	21.56	0-1	1
	1750	20350	10	16QAM	25	0	20.71	0-2	2
	1750	20350	10	16QAM	25	12	20.63	0-2	2
1750	20350	10	16QAM	25	25	20.83	0-2	2	
1750	20350	10	16QAM	50	0	20.68	0-2	2	



FCC ID: ACJ9TGWW13B	 PCTEST ENGINEERING LABORATORY, INC.	SAR EVALUATION REPORT		Reviewed by: Quality Manager
Document S/N: OY1412152300.ACJ	Test Dates: 12/15/14 - 01/08/15	DUT Type: Wireless Module		Page 37 of 91

Table 8-26
LTE Band 4 (AWS) Conducted Powers – 5 MHz Bandwidth

	Frequency [MHz]	Channel	Bandwidth [MHz]	Modulation	RB Size	RB Offset	Conducted Power [dBm]	MPR Allowed per 3GPP [dB]	MPR [dB]
Low	1712.5	19975	5	QPSK	1	0	22.87	0	0
	1712.5	19975	5	QPSK	1	12	22.79	0	0
	1712.5	19975	5	QPSK	1	24	22.81	0	0
	1712.5	19975	5	QPSK	12	0	21.81	0-1	1
	1712.5	19975	5	QPSK	12	6	21.77	0-1	1
	1712.5	19975	5	QPSK	12	13	21.75	0-1	1
	1712.5	19975	5	QPSK	25	0	21.68	0-1	1
	1712.5	19975	5	16-QAM	1	0	21.92	0-1	1
	1712.5	19975	5	16-QAM	1	12	21.88	0-1	1
	1712.5	19975	5	16-QAM	1	24	21.94	0-1	1
	1712.5	19975	5	16-QAM	12	0	20.84	0-2	2
	1712.5	19975	5	16-QAM	12	6	20.76	0-2	2
1712.5	19975	5	16-QAM	12	13	20.70	0-2	2	
1712.5	19975	5	16-QAM	25	0	20.66	0-2	2	
Mid	1732.5	20175	5	QPSK	1	0	22.84	0	0
	1732.5	20175	5	QPSK	1	12	22.83	0	0
	1732.5	20175	5	QPSK	1	24	22.85	0	0
	1732.5	20175	5	QPSK	12	0	21.88	0-1	1
	1732.5	20175	5	QPSK	12	6	21.88	0-1	1
	1732.5	20175	5	QPSK	12	13	21.87	0-1	1
	1732.5	20175	5	QPSK	25	0	21.80	0-1	1
	1732.5	20175	5	16-QAM	1	0	21.75	0-1	1
	1732.5	20175	5	16-QAM	1	12	21.69	0-1	1
	1732.5	20175	5	16-QAM	1	24	21.72	0-1	1
	1732.5	20175	5	16-QAM	12	0	20.90	0-2	2
	1732.5	20175	5	16-QAM	12	6	20.92	0-2	2
1732.5	20175	5	16-QAM	12	13	20.92	0-2	2	
1732.5	20175	5	16-QAM	25	0	20.82	0-2	2	
High	1752.5	20375	5	QPSK	1	0	22.94	0	0
	1752.5	20375	5	QPSK	1	12	23.01	0	0
	1752.5	20375	5	QPSK	1	24	22.81	0	0
	1752.5	20375	5	QPSK	12	0	21.93	0-1	1
	1752.5	20375	5	QPSK	12	6	21.97	0-1	1
	1752.5	20375	5	QPSK	12	13	21.92	0-1	1
	1752.5	20375	5	QPSK	25	0	21.81	0-1	1
	1752.5	20375	5	16-QAM	1	0	21.77	0-1	1
	1752.5	20375	5	16-QAM	1	12	21.79	0-1	1
	1752.5	20375	5	16-QAM	1	24	21.64	0-1	1
	1752.5	20375	5	16-QAM	12	0	20.95	0-2	2
	1752.5	20375	5	16-QAM	12	6	20.78	0-2	2
1752.5	20375	5	16-QAM	12	13	20.81	0-2	2	
1752.5	20375	5	16-QAM	25	0	20.67	0-2	2	





FCC ID: ACJ9TGWW13B	 PCTEST ENGINEERING LABORATORY, INC.	SAR EVALUATION REPORT		Reviewed by: Quality Manager
Document S/N: OY1412152300.ACJ	Test Dates: 12/15/14 - 01/08/15	DUT Type: Wireless Module	Page 38 of 91	



Table 8-27
LTE Band 4 (AWS) Conducted Powers – 3 MHz Bandwidth

	Frequency [MHz]	Channel	Bandwidth [MHz]	Modulation	RB Size	RB Offset	Conducted Power [dBm]	MPR Allowed per 3GPP [dB]	MPR [dB]
Low	1711.5	19965	3	QPSK	1	0	22.86	0	0
	1711.5	19965	3	QPSK	1	7	22.89	0	0
	1711.5	19965	3	QPSK	1	14	22.84	0	0
	1711.5	19965	3	QPSK	8	0	21.86	0-1	1
	1711.5	19965	3	QPSK	8	4	21.69	0-1	1
	1711.5	19965	3	QPSK	8	7	21.81	0-1	1
	1711.5	19965	3	QPSK	15	0	21.83	0-1	1
	1711.5	19965	3	16-QAM	1	0	21.73	0-1	1
	1711.5	19965	3	16-QAM	1	7	21.67	0-1	1
	1711.5	19965	3	16-QAM	1	14	21.66	0-1	1
	1711.5	19965	3	16-QAM	8	0	20.79	0-2	2
	1711.5	19965	3	16-QAM	8	4	20.54	0-2	2
1711.5	19965	3	16-QAM	8	7	20.69	0-2	2	
1711.5	19965	3	16-QAM	15	0	20.52	0-2	2	
Mid	1732.5	20175	3	QPSK	1	0	22.94	0	0
	1732.5	20175	3	QPSK	1	7	22.83	0	0
	1732.5	20175	3	QPSK	1	14	22.88	0	0
	1732.5	20175	3	QPSK	8	0	21.95	0-1	1
	1732.5	20175	3	QPSK	8	4	21.91	0-1	1
	1732.5	20175	3	QPSK	8	7	21.85	0-1	1
	1732.5	20175	3	QPSK	15	0	21.87	0-1	1
	1732.5	20175	3	16-QAM	1	0	22.28	0-1	1
	1732.5	20175	3	16-QAM	1	7	22.19	0-1	1
	1732.5	20175	3	16-QAM	1	14	22.33	0-1	1
	1732.5	20175	3	16-QAM	8	0	20.80	0-2	2
	1732.5	20175	3	16-QAM	8	4	20.92	0-2	2
1732.5	20175	3	16-QAM	8	7	20.88	0-2	2	
1732.5	20175	3	16-QAM	15	0	20.92	0-2	2	
High	1753.5	20385	3	QPSK	1	0	22.90	0	0
	1753.5	20385	3	QPSK	1	7	22.82	0	0
	1753.5	20385	3	QPSK	1	14	22.68	0	0
	1753.5	20385	3	QPSK	8	0	21.76	0-1	1
	1753.5	20385	3	QPSK	8	4	21.87	0-1	1
	1753.5	20385	3	QPSK	8	7	21.92	0-1	1
	1753.5	20385	3	QPSK	15	0	21.56	0-1	1
	1753.5	20385	3	16-QAM	1	0	21.64	0-1	1
	1753.5	20385	3	16-QAM	1	7	21.67	0-1	1
	1753.5	20385	3	16-QAM	1	14	21.67	0-1	1
	1753.5	20385	3	16-QAM	8	0	20.99	0-2	2
	1753.5	20385	3	16-QAM	8	4	20.91	0-2	2
1753.5	20385	3	16-QAM	8	7	20.80	0-2	2	
1753.5	20385	3	16-QAM	15	0	20.91	0-2	2	

FCC ID: ACJ9TGWW13B	 PCTEST ENGINEERING LABORATORY, INC.	SAR EVALUATION REPORT		Reviewed by: Quality Manager
Document S/N: OY1412152300.ACJ	Test Dates: 12/15/14 - 01/08/15	DUT Type: Wireless Module	Page 39 of 91	

**Table 8-28
LTE Band 4 (AWS) Conducted Powers – 1.4 MHz Bandwidth**

	Frequency [MHz]	Channel	Bandwidth [MHz]	Modulation	RB Size	RB Offset	Conducted Power [dBm]	MPR Allowed per 3GPP [dB]	MPR [dB]
Low	1710.7	19957	1.4	QPSK	1	0	22.80	0	0
	1710.7	19957	1.4	QPSK	1	2	22.89	0	0
	1710.7	19957	1.4	QPSK	1	5	22.81	0	0
	1710.7	19957	1.4	QPSK	3	0	22.80	0	0
	1710.7	19957	1.4	QPSK	3	2	22.74	0	0
	1710.7	19957	1.4	QPSK	3	3	22.73	0	0
	1710.7	19957	1.4	QPSK	6	0	21.87	0-1	1
	1710.7	19957	1.4	16-QAM	1	0	21.66	0-1	1
	1710.7	19957	1.4	16-QAM	1	2	21.69	0-1	1
	1710.7	19957	1.4	16-QAM	3	0	21.66	0-1	1
	1710.7	19957	1.4	16-QAM	3	2	21.63	0-1	1
	1710.7	19957	1.4	16-QAM	3	3	21.65	0-1	1
1710.7	19957	1.4	16-QAM	6	0	20.74	0-2	2	
Mid	1732.5	20175	1.4	QPSK	1	0	22.96	0	0
	1732.5	20175	1.4	QPSK	1	2	22.89	0	0
	1732.5	20175	1.4	QPSK	1	5	22.93	0	0
	1732.5	20175	1.4	QPSK	3	0	22.85	0	0
	1732.5	20175	1.4	QPSK	3	2	22.86	0	0
	1732.5	20175	1.4	QPSK	3	3	23.00	0	0
	1732.5	20175	1.4	QPSK	6	0	21.90	0-1	1
	1732.5	20175	1.4	16-QAM	1	0	21.60	0-1	1
	1732.5	20175	1.4	16-QAM	1	2	21.59	0-1	1
	1732.5	20175	1.4	16-QAM	1	5	21.63	0-1	1
	1732.5	20175	1.4	16-QAM	3	0	21.83	0-1	1
	1732.5	20175	1.4	16-QAM	3	2	21.86	0-1	1
1732.5	20175	1.4	16-QAM	3	3	21.85	0-1	1	
1732.5	20175	1.4	16-QAM	6	0	21.01	0-2	2	
High	1754.3	20393	1.4	QPSK	1	0	22.72	0	0
	1754.3	20393	1.4	QPSK	1	2	22.65	0	0
	1754.3	20393	1.4	QPSK	1	5	22.72	0	0
	1754.3	20393	1.4	QPSK	3	0	22.79	0	0
	1754.3	20393	1.4	QPSK	3	2	22.67	0	0
	1754.3	20393	1.4	QPSK	3	3	22.70	0	0
	1754.3	20393	1.4	QPSK	6	0	21.76	0-1	1
	1754.3	20393	1.4	16-QAM	1	0	21.71	0-1	1
	1754.3	20393	1.4	16-QAM	1	2	21.50	0-1	1
	1754.3	20393	1.4	16-QAM	1	5	21.55	0-1	1
	1754.3	20393	1.4	16-QAM	3	0	21.75	0-1	1
	1754.3	20393	1.4	16-QAM	3	2	21.66	0-1	1
1754.3	20393	1.4	16-QAM	3	3	21.64	0-1	1	
1754.3	20393	1.4	16-QAM	6	0	20.80	0-2	2	



FCC ID: ACJ9TGWW13B	 PCTEST ENGINEERING LABORATORY, INC.	SAR EVALUATION REPORT		Reviewed by: Quality Manager
Document S/N: OY1412152300.ACJ	Test Dates: 12/15/14 - 01/08/15	DUT Type: Wireless Module	Page 40 of 91	

8.4.8 LTE Band 4 (AWS) Reduced Power

Table 8-29
LTE Band 4 (AWS) Conducted Powers – 20 MHz Bandwidth



	Frequency [MHz]	Channel	Bandwidth [MHz]	Modulation	RB Size	RB Offset	Conducted Power [dBm]	MPR Allowed per 3GPP [dB]	MPR [dB]
Mid	1732.5	20175	20	QPSK	1	0	10.24	0	0
	1732.5	20175	20	QPSK	1	50	10.65	0	0
	1732.5	20175	20	QPSK	1	99	10.14	0	0
	1732.5	20175	20	QPSK	50	0	10.59	0-1	0
	1732.5	20175	20	QPSK	50	25	10.60	0-1	0
	1732.5	20175	20	QPSK	50	50	10.12	0-1	0
	1732.5	20175	20	QPSK	100	0	10.44	0-1	0
	1732.5	20175	20	16QAM	1	0	10.17	0-1	0
	1732.5	20175	20	16QAM	1	50	10.62	0-1	0
	1732.5	20175	20	16QAM	1	99	10.09	0-1	0
	1732.5	20175	20	16QAM	50	0	10.29	0-2	0
	1732.5	20175	20	16QAM	50	25	10.33	0-2	0
	1732.5	20175	20	16QAM	50	50	10.08	0-2	0
	1732.5	20175	20	16QAM	100	0	10.17	0-2	0

Note: LTE Band 4 at 20 MHz bandwidth does not support three non-overlapping channels. Per KDB Publication 941225 D05v02, when a device supports overlapping channel assignment in a channel bandwidth configuration, the middle channel of the group of overlapping channels should be selected for testing.

FCC ID: ACJ9TGWW13B	 PCTEST ENGINEERING LABORATORY, INC.	SAR EVALUATION REPORT		Reviewed by: Quality Manager
Document S/N: OY1412152300.ACJ	Test Dates: 12/15/14 - 01/08/15	DUT Type: Wireless Module		Page 41 of 91

**Table 8-30
LTE Band 4 (AWS) Conducted Powers – 15 MHz Bandwidth**

	Frequency [MHz]	Channel	Bandwidth [MHz]	Modulation	RB Size	RB Offset	Conducted Power [dBm]	MPR Allowed per 3GPP [dB]	MPR [dB]
Low	1717.5	20025	15	QPSK	1	0	10.13	0	0
	1717.5	20025	15	QPSK	1	36	10.60	0	0
	1717.5	20025	15	QPSK	1	74	10.12	0	0
	1717.5	20025	15	QPSK	36	0	10.54	0-1	0
	1717.5	20025	15	QPSK	36	18	10.77	0-1	0
	1717.5	20025	15	QPSK	36	37	10.58	0-1	0
	1717.5	20025	15	QPSK	75	0	10.55	0-1	0
	1717.5	20025	15	16QAM	1	0	10.20	0-1	0
	1717.5	20025	15	16QAM	1	36	10.57	0-1	0
	1717.5	20025	15	16QAM	1	74	10.11	0-1	0
	1717.5	20025	15	16QAM	36	0	10.26	0-2	0
	1717.5	20025	15	16QAM	36	18	10.42	0-2	0
1717.5	20025	15	16QAM	36	37	10.21	0-2	0	
1717.5	20025	15	16QAM	75	0	10.37	0-2	0	
Mid	1732.5	20175	15	QPSK	1	0	10.20	0	0
	1732.5	20175	15	QPSK	1	36	10.85	0	0
	1732.5	20175	15	QPSK	1	74	10.09	0	0
	1732.5	20175	15	QPSK	36	0	10.68	0-1	0
	1732.5	20175	15	QPSK	36	18	10.74	0-1	0
	1732.5	20175	15	QPSK	36	37	10.54	0-1	0
	1732.5	20175	15	QPSK	75	0	10.63	0-1	0
	1732.5	20175	15	16QAM	1	0	10.61	0-1	0
	1732.5	20175	15	16QAM	1	36	10.84	0-1	0
	1732.5	20175	15	16QAM	1	74	10.11	0-1	0
	1732.5	20175	15	16QAM	36	0	10.75	0-2	0
	1732.5	20175	15	16QAM	36	18	10.70	0-2	0
1732.5	20175	15	16QAM	36	37	10.34	0-2	0	
1732.5	20175	15	16QAM	75	0	10.47	0-2	0	
High	1747.5	20325	15	QPSK	1	0	10.29	0	0
	1747.5	20325	15	QPSK	1	36	10.53	0	0
	1747.5	20325	15	QPSK	1	74	10.12	0	0
	1747.5	20325	15	QPSK	36	0	10.41	0-1	0
	1747.5	20325	15	QPSK	36	18	10.34	0-1	0
	1747.5	20325	15	QPSK	36	37	10.14	0-1	0
	1747.5	20325	15	QPSK	75	0	10.18	0-1	0
	1747.5	20325	15	16QAM	1	0	10.13	0-1	0
	1747.5	20325	15	16QAM	1	36	10.10	0-1	0
	1747.5	20325	15	16QAM	1	74	10.09	0-1	0
	1747.5	20325	15	16QAM	36	0	10.21	0-2	0
	1747.5	20325	15	16QAM	36	18	10.07	0-2	0
1747.5	20325	15	16QAM	36	37	10.11	0-2	0	
1747.5	20325	15	16QAM	75	0	10.05	0-2	0	

FCC ID: ACJ9TGWW13B	 PCTEST ENGINEERING LABORATORY, INC.	SAR EVALUATION REPORT		Reviewed by: Quality Manager
Document S/N: OY1412152300.ACJ	Test Dates: 12/15/14 - 01/08/15	DUT Type: Wireless Module		Page 42 of 91

**Table 8-31
LTE Band 4 (AWS) Conducted Powers – 10 MHz Bandwidth**

	Frequency [MHz]	Channel	Bandwidth [MHz]	Modulation	RB Size	RB Offset	Conducted Power [dBm]	MPR Allowed per 3GPP [dB]	MPR [dB]
Low	1715	20000	10	QPSK	1	0	10.09	0	0
	1715	20000	10	QPSK	1	25	10.55	0	0
	1715	20000	10	QPSK	1	49	10.17	0	0
	1715	20000	10	QPSK	25	0	10.49	0-1	0
	1715	20000	10	QPSK	25	12	10.74	0-1	0
	1715	20000	10	QPSK	25	25	10.56	0-1	0
	1715	20000	10	QPSK	50	0	10.58	0-1	0
	1715	20000	10	16QAM	1	0	10.17	0-1	0
	1715	20000	10	16QAM	1	25	10.59	0-1	0
	1715	20000	10	16QAM	25	0	10.21	0-2	0
	1715	20000	10	16QAM	25	12	10.38	0-2	0
	1715	20000	10	16QAM	25	25	10.26	0-2	0
Mid	1732.5	20175	10	QPSK	1	0	10.23	0	0
	1732.5	20175	10	QPSK	1	25	10.83	0	0
	1732.5	20175	10	QPSK	1	49	10.04	0	0
	1732.5	20175	10	QPSK	25	0	10.70	0-1	0
	1732.5	20175	10	QPSK	25	12	10.75	0-1	0
	1732.5	20175	10	QPSK	25	25	10.54	0-1	0
	1732.5	20175	10	QPSK	50	0	10.67	0-1	0
	1732.5	20175	10	16QAM	1	0	10.56	0-1	0
	1732.5	20175	10	16QAM	1	25	10.79	0-1	0
	1732.5	20175	10	16QAM	1	49	10.06	0-1	0
	1732.5	20175	10	16QAM	25	0	10.74	0-2	0
	1732.5	20175	10	16QAM	25	12	10.75	0-2	0
High	1750	20350	10	QPSK	1	0	10.26	0	0
	1750	20350	10	QPSK	1	25	10.50	0	0
	1750	20350	10	QPSK	1	49	10.13	0	0
	1750	20350	10	QPSK	25	0	10.38	0-1	0
	1750	20350	10	QPSK	25	12	10.36	0-1	0
	1750	20350	10	QPSK	25	25	10.09	0-1	0
	1750	20350	10	QPSK	50	0	10.20	0-1	0
	1750	20350	10	16QAM	1	0	10.12	0-1	0
	1750	20350	10	16QAM	1	25	10.12	0-1	0
	1750	20350	10	16QAM	1	49	10.06	0-1	0
	1750	20350	10	16QAM	25	0	10.19	0-2	0
	1750	20350	10	16QAM	25	12	10.04	0-2	0
1750	20350	10	16QAM	25	25	10.06	0-2	0	
1750	20350	10	16QAM	50	0	10.04	0-2	0	



FCC ID: ACJ9TGWW13B	 PCTEST ENGINEERING LABORATORY, INC.	SAR EVALUATION REPORT		Reviewed by: Quality Manager
Document S/N: OY1412152300.ACJ	Test Dates: 12/15/14 - 01/08/15	DUT Type: Wireless Module		Page 43 of 91

Table 8-32
LTE Band 4 (AWS) Conducted Powers – 5 MHz Bandwidth

	Frequency [MHz]	Channel	Bandwidth [MHz]	Modulation	RB Size	RB Offset	Conducted Power [dBm]	MPR Allowed per 3GPP [dB]	MPR [dB]
Low	1712.5	19975	5	QPSK	1	0	10.14	0	0
	1712.5	19975	5	QPSK	1	12	10.64	0	0
	1712.5	19975	5	QPSK	1	24	10.09	0	0
	1712.5	19975	5	QPSK	12	0	10.52	0-1	0
	1712.5	19975	5	QPSK	12	6	10.81	0-1	0
	1712.5	19975	5	QPSK	12	13	10.59	0-1	0
	1712.5	19975	5	QPSK	25	0	10.57	0-1	0
	1712.5	19975	5	16-QAM	1	0	10.17	0-1	0
	1712.5	19975	5	16-QAM	1	12	10.58	0-1	0
	1712.5	19975	5	16-QAM	1	24	10.09	0-1	0
	1712.5	19975	5	16-QAM	12	0	10.29	0-2	0
	1712.5	19975	5	16-QAM	12	6	10.45	0-2	0
1712.5	19975	5	16-QAM	12	13	10.16	0-2	0	
1712.5	19975	5	16-QAM	25	0	10.36	0-2	0	
Mid	1732.5	20175	5	QPSK	1	0	10.17	0	0
	1732.5	20175	5	QPSK	1	12	10.85	0	0
	1732.5	20175	5	QPSK	1	24	10.06	0	0
	1732.5	20175	5	QPSK	12	0	10.68	0-1	0
	1732.5	20175	5	QPSK	12	6	10.74	0-1	0
	1732.5	20175	5	QPSK	12	13	10.52	0-1	0
	1732.5	20175	5	QPSK	25	0	10.64	0-1	0
	1732.5	20175	5	16-QAM	1	0	10.58	0-1	0
	1732.5	20175	5	16-QAM	1	12	10.80	0-1	0
	1732.5	20175	5	16-QAM	1	24	10.13	0-1	0
	1732.5	20175	5	16-QAM	12	0	10.72	0-2	0
	1732.5	20175	5	16-QAM	12	6	10.67	0-2	0
1732.5	20175	5	16-QAM	12	13	10.33	0-2	0	
1732.5	20175	5	16-QAM	25	0	10.50	0-2	0	
High	1752.5	20375	5	QPSK	1	0	10.28	0	0
	1752.5	20375	5	QPSK	1	12	10.54	0	0
	1752.5	20375	5	QPSK	1	24	10.11	0	0
	1752.5	20375	5	QPSK	12	0	10.40	0-1	0
	1752.5	20375	5	QPSK	12	6	10.33	0-1	0
	1752.5	20375	5	QPSK	12	13	10.11	0-1	0
	1752.5	20375	5	QPSK	25	0	10.13	0-1	0
	1752.5	20375	5	16-QAM	1	0	10.17	0-1	0
	1752.5	20375	5	16-QAM	1	12	10.10	0-1	0
	1752.5	20375	5	16-QAM	1	24	10.07	0-1	0
	1752.5	20375	5	16-QAM	12	0	10.23	0-2	0
	1752.5	20375	5	16-QAM	12	6	10.08	0-2	0
1752.5	20375	5	16-QAM	12	13	10.15	0-2	0	
1752.5	20375	5	16-QAM	25	0	10.03	0-2	0	



FCC ID: ACJ9TGWW13B	 PCTEST ENGINEERING LABORATORY, INC.	SAR EVALUATION REPORT		Reviewed by: Quality Manager
Document S/N: OY1412152300.ACJ	Test Dates: 12/15/14 - 01/08/15	DUT Type: Wireless Module		Page 44 of 91

Table 8-33
LTE Band 4 (AWS) Conducted Powers – 3 MHz Bandwidth

	Frequency [MHz]	Channel	Bandwidth [MHz]	Modulation	RB Size	RB Offset	Conducted Power [dBm]	MPR Allowed per 3GPP [dB]	MPR [dB]
Low	1711.5	19965	3	QPSK	1	0	10.15	0	0
	1711.5	19965	3	QPSK	1	7	10.58	0	0
	1711.5	19965	3	QPSK	1	14	10.16	0	0
	1711.5	19965	3	QPSK	8	0	10.50	0-1	0
	1711.5	19965	3	QPSK	8	4	10.80	0-1	0
	1711.5	19965	3	QPSK	8	7	10.53	0-1	0
	1711.5	19965	3	QPSK	15	0	10.54	0-1	0
	1711.5	19965	3	16-QAM	1	0	10.25	0-1	0
	1711.5	19965	3	16-QAM	1	7	10.62	0-1	0
	1711.5	19965	3	16-QAM	1	14	10.14	0-1	0
	1711.5	19965	3	16-QAM	8	0	10.25	0-2	0
	1711.5	19965	3	16-QAM	8	4	10.38	0-2	0
1711.5	19965	3	16-QAM	8	7	10.17	0-2	0	
1711.5	19965	3	16-QAM	15	0	10.33	0-2	0	
Mid	1732.5	20175	3	QPSK	1	0	10.24	0	0
	1732.5	20175	3	QPSK	1	7	10.80	0	0
	1732.5	20175	3	QPSK	1	14	10.06	0	0
	1732.5	20175	3	QPSK	8	0	10.64	0-1	0
	1732.5	20175	3	QPSK	8	4	10.77	0-1	0
	1732.5	20175	3	QPSK	8	7	10.57	0-1	0
	1732.5	20175	3	QPSK	15	0	10.60	0-1	0
	1732.5	20175	3	16-QAM	1	0	10.63	0-1	0
	1732.5	20175	3	16-QAM	1	7	10.88	0-1	0
	1732.5	20175	3	16-QAM	1	14	10.16	0-1	0
	1732.5	20175	3	16-QAM	8	0	10.72	0-2	0
	1732.5	20175	3	16-QAM	8	4	10.73	0-2	0
1732.5	20175	3	16-QAM	8	7	10.38	0-2	0	
1732.5	20175	3	16-QAM	15	0	10.43	0-2	0	
High	1753.5	20385	3	QPSK	1	0	10.24	0	0
	1753.5	20385	3	QPSK	1	7	10.57	0	0
	1753.5	20385	3	QPSK	1	14	10.09	0	0
	1753.5	20385	3	QPSK	8	0	10.36	0-1	0
	1753.5	20385	3	QPSK	8	4	10.38	0-1	0
	1753.5	20385	3	QPSK	8	7	10.15	0-1	0
	1753.5	20385	3	QPSK	15	0	10.19	0-1	0
	1753.5	20385	3	16-QAM	1	0	10.12	0-1	0
	1753.5	20385	3	16-QAM	1	7	10.05	0-1	0
	1753.5	20385	3	16-QAM	1	14	10.06	0-1	0
	1753.5	20385	3	16-QAM	8	0	10.22	0-2	0
	1753.5	20385	3	16-QAM	8	4	10.04	0-2	0
1753.5	20385	3	16-QAM	8	7	10.11	0-2	0	
1753.5	20385	3	16-QAM	15	0	10.00	0-2	0	





FCC ID: ACJ9TGWW13B	 PCTEST ENGINEERING LABORATORY, INC.	SAR EVALUATION REPORT		Reviewed by: Quality Manager
Document S/N: OY1412152300.ACJ	Test Dates: 12/15/14 - 01/08/15	DUT Type: Wireless Module	Page 45 of 91	

Table 8-34
LTE Band 4 (AWS) Conducted Powers – 1.4 MHz Bandwidth



	Frequency [MHz]	Channel	Bandwidth [MHz]	Modulation	RB Size	RB Offset	Conducted Power [dBm]	MPR Allowed per 3GPP [dB]	MPR [dB]
Low	1710.7	19957	1.4	QPSK	1	0	10.12	0	0
	1710.7	19957	1.4	QPSK	1	2	10.58	0	0
	1710.7	19957	1.4	QPSK	1	5	10.16	0	0
	1710.7	19957	1.4	QPSK	3	0	10.46	0	0
	1710.7	19957	1.4	QPSK	3	2	10.85	0	0
	1710.7	19957	1.4	QPSK	3	3	10.56	0	0
	1710.7	19957	1.4	QPSK	6	0	10.53	0-1	0
	1710.7	19957	1.4	16-QAM	1	0	10.26	0-1	0
	1710.7	19957	1.4	16-QAM	1	2	10.61	0-1	0
	1710.7	19957	1.4	16-QAM	1	5	10.14	0-1	0
	1710.7	19957	1.4	16-QAM	3	0	10.20	0-1	0
	1710.7	19957	1.4	16-QAM	3	2	10.41	0-1	0
1710.7	19957	1.4	16-QAM	3	3	10.22	0-1	0	
1710.7	19957	1.4	16-QAM	6	0	10.28	0-2	0	
Mid	1732.5	20175	1.4	QPSK	1	0	10.25	0	0
	1732.5	20175	1.4	QPSK	1	2	10.82	0	0
	1732.5	20175	1.4	QPSK	1	5	10.10	0	0
	1732.5	20175	1.4	QPSK	3	0	10.63	0	0
	1732.5	20175	1.4	QPSK	3	2	10.76	0	0
	1732.5	20175	1.4	QPSK	3	3	10.57	0	0
	1732.5	20175	1.4	QPSK	6	0	10.63	0-1	0
	1732.5	20175	1.4	16-QAM	1	0	10.61	0-1	0
	1732.5	20175	1.4	16-QAM	1	2	10.89	0-1	0
	1732.5	20175	1.4	16-QAM	1	5	10.12	0-1	0
	1732.5	20175	1.4	16-QAM	3	0	10.74	0-1	0
	1732.5	20175	1.4	16-QAM	3	2	10.70	0-1	0
1732.5	20175	1.4	16-QAM	3	3	10.43	0-1	0	
1732.5	20175	1.4	16-QAM	6	0	10.41	0-2	0	
High	1754.3	20393	1.4	QPSK	1	0	10.25	0	0
	1754.3	20393	1.4	QPSK	1	2	10.62	0	0
	1754.3	20393	1.4	QPSK	1	5	10.14	0	0
	1754.3	20393	1.4	QPSK	3	0	10.32	0	0
	1754.3	20393	1.4	QPSK	3	2	10.35	0	0
	1754.3	20393	1.4	QPSK	3	3	10.19	0	0
	1754.3	20393	1.4	QPSK	6	0	10.16	0-1	0
	1754.3	20393	1.4	16-QAM	1	0	10.08	0-1	0
	1754.3	20393	1.4	16-QAM	1	2	10.09	0-1	0
	1754.3	20393	1.4	16-QAM	1	5	10.04	0-1	0
	1754.3	20393	1.4	16-QAM	3	0	10.26	0-1	0
	1754.3	20393	1.4	16-QAM	3	2	10.09	0-1	0
1754.3	20393	1.4	16-QAM	3	3	10.16	0-1	0	
1754.3	20393	1.4	16-QAM	6	0	9.99	0-2	0	

FCC ID: ACJ9TGWW13B	 PCTEST ENGINEERING LABORATORY, INC.	SAR EVALUATION REPORT		Reviewed by: Quality Manager
Document S/N: OY1412152300.ACJ	Test Dates: 12/15/14 - 01/08/15	DUT Type: Wireless Module		Page 46 of 91

8.4.9 LTE Band 25 (PCS) Maximum Power

Table 8-35
LTE Band 25 (PCS) Conducted Powers – 20 MHz Bandwidth

	Frequency [MHz]	Channel	Bandwidth [MHz]	Modulation	RB Size	RB Offset	Conducted Power [dBm]	MPR Allowed per 3GPP [dB]	MPR [dB]
Low	1860	26140	20	QPSK	1	0	22.82	0	0
	1860	26140	20	QPSK	1	50	22.84	0	0
	1860	26140	20	QPSK	1	99	22.94	0	0
	1860	26140	20	QPSK	50	0	21.62	0-1	1
	1860	26140	20	QPSK	50	25	21.76	0-1	1
	1860	26140	20	QPSK	50	50	21.56	0-1	1
	1860	26140	20	QPSK	100	0	21.50	0-1	1
	1860	26140	20	16QAM	1	0	21.57	0-1	1
	1860	26140	20	16QAM	1	50	21.60	0-1	1
	1860	26140	20	16QAM	1	99	21.75	0-1	1
	1860	26140	20	16QAM	50	0	20.68	0-2	2
	1860	26140	20	16QAM	50	25	20.62	0-2	2
	1860	26140	20	16QAM	50	50	20.66	0-2	2
	1860	26140	20	16QAM	100	0	20.67	0-2	2
Mid	1882.5	26365	20	QPSK	1	0	22.78	0	0
	1882.5	26365	20	QPSK	1	50	22.68	0	0
	1882.5	26365	20	QPSK	1	99	22.65	0	0
	1882.5	26365	20	QPSK	50	0	21.77	0-1	1
	1882.5	26365	20	QPSK	50	25	21.74	0-1	1
	1882.5	26365	20	QPSK	50	50	21.66	0-1	1
	1882.5	26365	20	QPSK	100	0	21.61	0-1	1
	1882.5	26365	20	16QAM	1	0	22.30	0-1	1
	1882.5	26365	20	16QAM	1	50	22.19	0-1	1
	1882.5	26365	20	16QAM	1	99	22.06	0-1	1
	1882.5	26365	20	16QAM	50	0	20.83	0-2	2
	1882.5	26365	20	16QAM	50	25	20.63	0-2	2
	1882.5	26365	20	16QAM	50	50	20.61	0-2	2
	1882.5	26365	20	16QAM	100	0	20.60	0-2	2
High	1905	26590	20	QPSK	1	0	22.89	0	0
	1905	26590	20	QPSK	1	50	23.06	0	0
	1905	26590	20	QPSK	1	99	23.01	0	0
	1905	26590	20	QPSK	50	0	21.95	0-1	1
	1905	26590	20	QPSK	50	25	21.92	0-1	1
	1905	26590	20	QPSK	50	50	22.06	0-1	1
	1905	26590	20	QPSK	100	0	21.77	0-1	1
	1905	26590	20	16QAM	1	0	21.85	0-1	1
	1905	26590	20	16QAM	1	50	21.83	0-1	1
	1905	26590	20	16QAM	1	99	21.96	0-1	1
	1905	26590	20	16QAM	50	0	20.96	0-2	2
	1905	26590	20	16QAM	50	25	20.89	0-2	2
	1905	26590	20	16QAM	50	50	21.08	0-2	2
	1905	26590	20	16QAM	100	0	20.83	0-2	2

FCC ID: ACJ9TGWW13B	 PCTEST ENGINEERING LABORATORY, INC.	SAR EVALUATION REPORT		Reviewed by: Quality Manager
Document S/N: OY1412152300.ACJ	Test Dates: 12/15/14 - 01/08/15	DUT Type: Wireless Module	Page 47 of 91	

**Table 8-36
LTE Band 25 (PCS) Conducted Powers – 15 MHz Bandwidth**

	Frequency [MHz]	Channel	Bandwidth [MHz]	Modulation	RB Size	RB Offset	Conducted Power [dBm]	MPR Allowed per 3GPP [dB]	MPR [dB]
Low	1857.5	26115	15	QPSK	1	0	22.81	0	0
	1857.5	26115	15	QPSK	1	36	22.70	0	0
	1857.5	26115	15	QPSK	1	74	22.79	0	0
	1857.5	26115	15	QPSK	36	0	21.75	0-1	1
	1857.5	26115	15	QPSK	36	18	21.78	0-1	1
	1857.5	26115	15	QPSK	36	37	21.59	0-1	1
	1857.5	26115	15	QPSK	75	0	21.39	0-1	1
	1857.5	26115	15	16QAM	1	0	21.54	0-1	1
	1857.5	26115	15	16QAM	1	36	21.65	0-1	1
	1857.5	26115	15	16QAM	1	74	21.62	0-1	1
	1857.5	26115	15	16QAM	36	0	20.86	0-2	2
	1857.5	26115	15	16QAM	36	18	20.75	0-2	2
1857.5	26115	15	16QAM	36	37	20.62	0-2	2	
1857.5	26115	15	16QAM	75	0	20.78	0-2	2	
Mid	1882.5	26365	15	QPSK	1	0	22.76	0	0
	1882.5	26365	15	QPSK	1	36	22.83	0	0
	1882.5	26365	15	QPSK	1	74	22.77	0	0
	1882.5	26365	15	QPSK	36	0	21.79	0-1	1
	1882.5	26365	15	QPSK	36	18	21.59	0-1	1
	1882.5	26365	15	QPSK	36	37	21.86	0-1	1
	1882.5	26365	15	QPSK	75	0	21.80	0-1	1
	1882.5	26365	15	16QAM	1	0	22.41	0-1	1
	1882.5	26365	15	16QAM	1	36	22.31	0-1	1
	1882.5	26365	15	16QAM	1	74	22.11	0-1	1
	1882.5	26365	15	16QAM	36	0	20.81	0-2	2
	1882.5	26365	15	16QAM	36	18	20.83	0-2	2
1882.5	26365	15	16QAM	36	37	20.57	0-2	2	
1882.5	26365	15	16QAM	75	0	20.47	0-2	2	
High	1907.5	26615	15	QPSK	1	0	22.90	0	0
	1907.5	26615	15	QPSK	1	36	23.22	0	0
	1907.5	26615	15	QPSK	1	74	22.93	0	0
	1907.5	26615	15	QPSK	36	0	22.04	0-1	1
	1907.5	26615	15	QPSK	36	18	22.05	0-1	1
	1907.5	26615	15	QPSK	36	37	21.90	0-1	1
	1907.5	26615	15	QPSK	75	0	21.84	0-1	1
	1907.5	26615	15	16QAM	1	0	22.00	0-1	1
	1907.5	26615	15	16QAM	1	36	21.89	0-1	1
	1907.5	26615	15	16QAM	1	74	22.14	0-1	1
	1907.5	26615	15	16QAM	36	0	20.80	0-2	2
	1907.5	26615	15	16QAM	36	18	20.71	0-2	2
1907.5	26615	15	16QAM	36	37	21.01	0-2	2	
1907.5	26615	15	16QAM	75	0	20.64	0-2	2	



FCC ID: ACJ9TGWW13B	 PCTEST ENGINEERING LABORATORY, INC.	SAR EVALUATION REPORT		Reviewed by: Quality Manager
Document S/N: OY1412152300.ACJ	Test Dates: 12/15/14 - 01/08/15	DUT Type: Wireless Module		Page 48 of 91

Table 8-37
LTE Band 25 (PCS) Conducted Powers – 10 MHz Bandwidth

	Frequency [MHz]	Channel	Bandwidth [MHz]	Modulation	RB Size	RB Offset	Conducted Power [dBm]	MPR Allowed per 3GPP [dB]	MPR [dB]
Low	1855	26090	10	QPSK	1	0	22.93	0	0
	1855	26090	10	QPSK	1	25	22.90	0	0
	1855	26090	10	QPSK	1	49	22.94	0	0
	1855	26090	10	QPSK	25	0	21.68	0-1	1
	1855	26090	10	QPSK	25	12	21.77	0-1	1
	1855	26090	10	QPSK	25	25	21.40	0-1	1
	1855	26090	10	QPSK	50	0	21.47	0-1	1
	1855	26090	10	16QAM	1	0	21.60	0-1	1
	1855	26090	10	16QAM	1	25	21.57	0-1	1
	1855	26090	10	16QAM	1	49	21.72	0-1	1
	1855	26090	10	16QAM	25	0	20.98	0-2	2
	1855	26090	10	16QAM	25	12	20.80	0-2	2
Mid	1882.5	26365	10	QPSK	1	0	22.74	0	0
	1882.5	26365	10	QPSK	1	25	22.88	0	0
	1882.5	26365	10	QPSK	1	49	22.96	0	0
	1882.5	26365	10	QPSK	25	0	21.85	0-1	1
	1882.5	26365	10	QPSK	25	12	21.41	0-1	1
	1882.5	26365	10	QPSK	25	25	21.91	0-1	1
	1882.5	26365	10	QPSK	50	0	21.78	0-1	1
	1882.5	26365	10	16QAM	1	0	21.80	0-1	1
	1882.5	26365	10	16QAM	1	25	21.95	0-1	1
	1882.5	26365	10	16QAM	1	49	21.54	0-1	1
	1882.5	26365	10	16QAM	25	0	20.99	0-2	2
	1882.5	26365	10	16QAM	25	12	20.91	0-2	2
High	1910	26640	10	QPSK	1	0	22.99	0	0
	1910	26640	10	QPSK	1	25	23.41	0	0
	1910	26640	10	QPSK	1	49	22.92	0	0
	1910	26640	10	QPSK	25	0	22.23	0-1	1
	1910	26640	10	QPSK	25	12	21.89	0-1	1
	1910	26640	10	QPSK	25	25	22.03	0-1	1
	1910	26640	10	QPSK	50	0	21.80	0-1	1
	1910	26640	10	16QAM	1	0	21.93	0-1	1
	1910	26640	10	16QAM	1	25	21.77	0-1	1
	1910	26640	10	16QAM	1	49	22.34	0-1	1
	1910	26640	10	16QAM	25	0	20.85	0-2	2
	1910	26640	10	16QAM	25	12	20.78	0-2	2
1910	26640	10	16QAM	25	25	21.02	0-2	2	
1910	26640	10	16QAM	50	0	20.70	0-2	2	



FCC ID: ACJ9TGWW13B	 PCTEST ENGINEERING LABORATORY, INC.	SAR EVALUATION REPORT		Reviewed by: Quality Manager
Document S/N: OY1412152300.ACJ	Test Dates: 12/15/14 - 01/08/15	DUT Type: Wireless Module	Page 49 of 91	

Table 8-38
LTE Band 25 (PCS) Conducted Powers – 5 MHz Bandwidth

	Frequency [MHz]	Channel	Bandwidth [MHz]	Modulation	RB Size	RB Offset	Conducted Power [dBm]	MPR Allowed per 3GPP [dB]	MPR [dB]
Low	1852.5	26065	5	QPSK	1	0	22.80	0	0
	1852.5	26065	5	QPSK	1	12	22.72	0	0
	1852.5	26065	5	QPSK	1	24	23.03	0	0
	1852.5	26065	5	QPSK	12	0	21.87	0-1	1
	1852.5	26065	5	QPSK	12	6	21.95	0-1	1
	1852.5	26065	5	QPSK	12	13	21.31	0-1	1
	1852.5	26065	5	QPSK	25	0	21.56	0-1	1
	1852.5	26065	5	16-QAM	1	0	21.44	0-1	1
	1852.5	26065	5	16-QAM	1	12	21.56	0-1	1
	1852.5	26065	5	16-QAM	1	24	21.82	0-1	1
	1852.5	26065	5	16-QAM	12	0	20.92	0-2	2
	1852.5	26065	5	16-QAM	12	6	20.62	0-2	2
1852.5	26065	5	16-QAM	12	13	20.76	0-2	2	
1852.5	26065	5	16-QAM	25	0	20.76	0-2	2	
Mid	1882.5	26365	5	QPSK	1	0	22.75	0	0
	1882.5	26365	5	QPSK	1	12	22.76	0	0
	1882.5	26365	5	QPSK	1	24	22.78	0	0
	1882.5	26365	5	QPSK	12	0	21.95	0-1	1
	1882.5	26365	5	QPSK	12	6	21.32	0-1	1
	1882.5	26365	5	QPSK	12	13	21.73	0-1	1
	1882.5	26365	5	QPSK	25	0	21.80	0-1	1
	1882.5	26365	5	16-QAM	1	0	22.21	0-1	1
	1882.5	26365	5	16-QAM	1	12	22.31	0-1	1
	1882.5	26365	5	16-QAM	1	24	22.13	0-1	1
	1882.5	26365	5	16-QAM	12	0	20.81	0-2	2
	1882.5	26365	5	16-QAM	12	6	20.96	0-2	2
1882.5	26365	5	16-QAM	12	13	20.41	0-2	2	
1882.5	26365	5	16-QAM	25	0	20.45	0-2	2	
High	1912.5	26665	5	QPSK	1	0	23.02	0	0
	1912.5	26665	5	QPSK	1	12	23.56	0	0
	1912.5	26665	5	QPSK	1	24	22.97	0	0
	1912.5	26665	5	QPSK	12	0	22.15	0-1	1
	1912.5	26665	5	QPSK	12	6	22.06	0-1	1
	1912.5	26665	5	QPSK	12	13	22.01	0-1	1
	1912.5	26665	5	QPSK	25	0	21.71	0-1	1
	1912.5	26665	5	16-QAM	1	0	22.03	0-1	1
	1912.5	26665	5	16-QAM	1	12	21.77	0-1	1
	1912.5	26665	5	16-QAM	1	24	22.15	0-1	1
	1912.5	26665	5	16-QAM	12	0	20.91	0-2	2
	1912.5	26665	5	16-QAM	12	6	20.64	0-2	2
1912.5	26665	5	16-QAM	12	13	20.87	0-2	2	
1912.5	26665	5	16-QAM	25	0	20.71	0-2	2	



FCC ID: ACJ9TGWW13B	 PCTEST ENGINEERING LABORATORY, INC.	SAR EVALUATION REPORT		Reviewed by: Quality Manager
Document S/N: OY1412152300.ACJ	Test Dates: 12/15/14 - 01/08/15	DUT Type: Wireless Module		Page 50 of 91

Table 8-39
LTE Band 25 (PCS) Conducted Powers – 3 MHz Bandwidth

	Frequency [MHz]	Channel	Bandwidth [MHz]	Modulation	RB Size	RB Offset	Conducted Power [dBm]	MPR Allowed per 3GPP [dB]	MPR [dB]
Low	1851.5	26055	3	QPSK	1	0	22.93	0	0
	1851.5	26055	3	QPSK	1	7	22.82	0	0
	1851.5	26055	3	QPSK	1	14	23.04	0	0
	1851.5	26055	3	QPSK	8	0	21.74	0-1	1
	1851.5	26055	3	QPSK	8	4	22.09	0-1	1
	1851.5	26055	3	QPSK	8	7	21.36	0-1	1
	1851.5	26055	3	QPSK	15	0	21.64	0-1	1
	1851.5	26055	3	16-QAM	1	0	21.63	0-1	1
	1851.5	26055	3	16-QAM	1	7	21.44	0-1	1
	1851.5	26055	3	16-QAM	1	14	21.68	0-1	1
	1851.5	26055	3	16-QAM	8	0	21.03	0-2	2
	1851.5	26055	3	16-QAM	8	4	20.67	0-2	2
1851.5	26055	3	16-QAM	8	7	20.68	0-2	2	
1851.5	26055	3	16-QAM	15	0	20.59	0-2	2	
Mid	1882.5	26365	3	QPSK	1	0	22.74	0	0
	1882.5	26365	3	QPSK	1	7	22.87	0	0
	1882.5	26365	3	QPSK	1	14	22.81	0	0
	1882.5	26365	3	QPSK	8	0	21.90	0-1	1
	1882.5	26365	3	QPSK	8	4	21.50	0-1	1
	1882.5	26365	3	QPSK	8	7	21.59	0-1	1
	1882.5	26365	3	QPSK	15	0	21.92	0-1	1
	1882.5	26365	3	16-QAM	1	0	21.90	0-1	1
	1882.5	26365	3	16-QAM	1	7	21.89	0-1	1
	1882.5	26365	3	16-QAM	1	14	21.74	0-1	1
	1882.5	26365	3	16-QAM	8	0	20.92	0-2	2
	1882.5	26365	3	16-QAM	8	4	20.77	0-2	2
1882.5	26365	3	16-QAM	8	7	20.25	0-2	2	
1882.5	26365	3	16-QAM	15	0	20.61	0-2	2	
High	1913.5	26675	3	QPSK	1	0	22.86	0	0
	1913.5	26675	3	QPSK	1	7	23.42	0	0
	1913.5	26675	3	QPSK	1	14	22.80	0	0
	1913.5	26675	3	QPSK	8	0	21.11	0-1	1
	1913.5	26675	3	QPSK	8	4	21.92	0-1	1
	1913.5	26675	3	QPSK	8	7	22.06	0-1	1
	1913.5	26675	3	QPSK	15	0	21.83	0-1	1
	1913.5	26675	3	16-QAM	1	0	22.00	0-1	1
	1913.5	26675	3	16-QAM	1	7	21.85	0-1	1
	1913.5	26675	3	16-QAM	1	14	22.23	0-1	1
	1913.5	26675	3	16-QAM	8	0	20.82	0-2	2
	1913.5	26675	3	16-QAM	8	4	20.63	0-2	2
1913.5	26675	3	16-QAM	8	7	20.75	0-2	2	
1913.5	26675	3	16-QAM	15	0	20.56	0-2	2	





FCC ID: ACJ9TGWW13B	 PCTEST ENGINEERING LABORATORY, INC.	SAR EVALUATION REPORT		Reviewed by: Quality Manager
Document S/N: OY1412152300.ACJ	Test Dates: 12/15/14 - 01/08/15	DUT Type: Wireless Module	Page 51 of 91	

Table 8-40
LTE Band 25 (PCS) Conducted Powers – 1.4 MHz Bandwidth



	Frequency [MHz]	Channel	Bandwidth [MHz]	Modulation	RB Size	RB Offset	Conducted Power [dBm]	MPR Allowed per 3GPP [dB]	MPR [dB]
Low	1850.7	26047	1.4	QPSK	1	0	22.41	0	0
	1850.7	26047	1.4	QPSK	1	2	22.54	0	0
	1850.7	26047	1.4	QPSK	1	5	22.55	0	0
	1850.7	26047	1.4	QPSK	3	0	22.51	0	0
	1850.7	26047	1.4	QPSK	3	2	22.37	0	0
	1850.7	26047	1.4	QPSK	3	3	22.46	0	0
	1850.7	26047	1.4	QPSK	6	0	21.32	0-1	1
	1850.7	26047	1.4	16-QAM	1	0	21.31	0-1	1
	1850.7	26047	1.4	16-QAM	1	2	21.55	0-1	1
	1850.7	26047	1.4	16-QAM	1	5	21.37	0-1	1
	1850.7	26047	1.4	16-QAM	3	0	21.57	0-1	1
	1850.7	26047	1.4	16-QAM	3	2	21.28	0-1	1
1850.7	26047	1.4	16-QAM	3	3	21.18	0-1	1	
1850.7	26047	1.4	16-QAM	6	0	20.70	0-2	2	
Mid	1882.5	26365	1.4	QPSK	1	0	22.46	0	0
	1882.5	26365	1.4	QPSK	1	2	22.34	0	0
	1882.5	26365	1.4	QPSK	1	5	22.54	0	0
	1882.5	26365	1.4	QPSK	3	0	22.40	0	0
	1882.5	26365	1.4	QPSK	3	2	22.43	0	0
	1882.5	26365	1.4	QPSK	3	3	22.55	0	0
	1882.5	26365	1.4	QPSK	6	0	21.43	0-1	1
	1882.5	26365	1.4	16-QAM	1	0	21.51	0-1	1
	1882.5	26365	1.4	16-QAM	1	2	21.59	0-1	1
	1882.5	26365	1.4	16-QAM	1	5	21.49	0-1	1
	1882.5	26365	1.4	16-QAM	3	0	21.39	0-1	1
	1882.5	26365	1.4	16-QAM	3	2	21.43	0-1	1
1882.5	26365	1.4	16-QAM	3	3	21.28	0-1	1	
1882.5	26365	1.4	16-QAM	6	0	20.56	0-2	2	
High	1914.3	26683	1.4	QPSK	1	0	22.62	0	0
	1914.3	26683	1.4	QPSK	1	2	22.52	0	0
	1914.3	26683	1.4	QPSK	1	5	22.65	0	0
	1914.3	26683	1.4	QPSK	3	0	22.25	0	0
	1914.3	26683	1.4	QPSK	3	2	22.62	0	0
	1914.3	26683	1.4	QPSK	3	3	22.73	0	0
	1914.3	26683	1.4	QPSK	6	0	21.38	0-1	1
	1914.3	26683	1.4	16-QAM	1	0	21.36	0-1	1
	1914.3	26683	1.4	16-QAM	1	2	21.66	0-1	1
	1914.3	26683	1.4	16-QAM	1	5	21.41	0-1	1
	1914.3	26683	1.4	16-QAM	3	0	21.26	0-1	1
	1914.3	26683	1.4	16-QAM	3	2	21.43	0-1	1
1914.3	26683	1.4	16-QAM	3	3	21.17	0-1	1	
1914.3	26683	1.4	16-QAM	6	0	20.67	0-2	2	

FCC ID: ACJ9TGWW13B	 PCTEST ENGINEERING LABORATORY, INC.	SAR EVALUATION REPORT		Reviewed by: Quality Manager
Document S/N: OY1412152300.ACJ	Test Dates: 12/15/14 - 01/08/15	DUT Type: Wireless Module		Page 52 of 91

8.4.10 LTE Band 25 (PCS) Reduced Power

Table 8-41
LTE Band 25 (PCS) Conducted Powers – 20 MHz Bandwidth

	Frequency [MHz]	Channel	Bandwidth [MHz]	Modulation	RB Size	RB Offset	Conducted Power [dBm]	MPR Allowed per 3GPP [dB]	MPR [dB]
Low	1860	26140	20	QPSK	1	0	11.20	0	0
	1860	26140	20	QPSK	1	50	11.60	0	0
	1860	26140	20	QPSK	1	99	11.08	0	0
	1860	26140	20	QPSK	50	0	11.07	0-1	0
	1860	26140	20	QPSK	50	25	10.94	0-1	0
	1860	26140	20	QPSK	50	50	11.11	0-1	0
	1860	26140	20	QPSK	100	0	10.92	0-1	0
	1860	26140	20	16QAM	1	0	11.26	0-1	0
	1860	26140	20	16QAM	1	50	11.45	0-1	0
	1860	26140	20	16QAM	1	99	10.81	0-1	0
	1860	26140	20	16QAM	50	0	11.40	0-2	0
	1860	26140	20	16QAM	50	25	11.54	0-2	0
	1860	26140	20	16QAM	50	50	11.02	0-2	0
	1860	26140	20	16QAM	100	0	11.15	0-2	0
Mid	1882.5	26365	20	QPSK	1	0	10.61	0	0
	1882.5	26365	20	QPSK	1	50	11.15	0	0
	1882.5	26365	20	QPSK	1	99	10.89	0	0
	1882.5	26365	20	QPSK	50	0	10.77	0-1	0
	1882.5	26365	20	QPSK	50	25	10.61	0-1	0
	1882.5	26365	20	QPSK	50	50	11.09	0-1	0
	1882.5	26365	20	QPSK	100	0	11.05	0-1	0
	1882.5	26365	20	16QAM	1	0	10.52	0-1	0
	1882.5	26365	20	16QAM	1	50	10.77	0-1	0
	1882.5	26365	20	16QAM	1	99	11.14	0-1	0
	1882.5	26365	20	16QAM	50	0	10.61	0-2	0
	1882.5	26365	20	16QAM	50	25	11.04	0-2	0
	1882.5	26365	20	16QAM	50	50	11.11	0-2	0
	1882.5	26365	20	16QAM	100	0	11.03	0-2	0
High	1905	26590	20	QPSK	1	0	10.65	0	0
	1905	26590	20	QPSK	1	50	10.77	0	0
	1905	26590	20	QPSK	1	99	11.16	0	0
	1905	26590	20	QPSK	50	0	10.87	0-1	0
	1905	26590	20	QPSK	50	25	10.95	0-1	0
	1905	26590	20	QPSK	50	50	11.58	0-1	0
	1905	26590	20	QPSK	100	0	10.97	0-1	0
	1905	26590	20	16QAM	1	0	10.96	0-1	0
	1905	26590	20	16QAM	1	50	10.85	0-1	0
	1905	26590	20	16QAM	1	99	11.08	0-1	0
	1905	26590	20	16QAM	50	0	10.99	0-2	0
	1905	26590	20	16QAM	50	25	11.14	0-2	0
	1905	26590	20	16QAM	50	50	11.49	0-2	0
	1905	26590	20	16QAM	100	0	10.94	0-2	0

FCC ID: ACJ9TGWW13B	 PCTEST ENGINEERING LABORATORY, INC.	SAR EVALUATION REPORT		Reviewed by: Quality Manager
Document S/N: OY1412152300.ACJ	Test Dates: 12/15/14 - 01/08/15	DUT Type: Wireless Module	Page 53 of 91	

**Table 8-42
LTE Band 25 (PCS) Conducted Powers – 15 MHz Bandwidth**

	Frequency [MHz]	Channel	Bandwidth [MHz]	Modulation	RB Size	RB Offset	Conducted Power [dBm]	MPR Allowed per 3GPP [dB]	MPR [dB]
Low	1857.5	26115	15	QPSK	1	0	11.21	0	0
	1857.5	26115	15	QPSK	1	36	11.55	0	0
	1857.5	26115	15	QPSK	1	74	11.09	0	0
	1857.5	26115	15	QPSK	36	0	11.04	0-1	0
	1857.5	26115	15	QPSK	36	18	10.95	0-1	0
	1857.5	26115	15	QPSK	36	37	11.09	0-1	0
	1857.5	26115	15	QPSK	75	0	10.91	0-1	0
	1857.5	26115	15	16QAM	1	0	11.31	0-1	0
	1857.5	26115	15	16QAM	1	36	11.44	0-1	0
	1857.5	26115	15	16QAM	36	0	11.36	0-2	0
	1857.5	26115	15	16QAM	36	18	11.59	0-2	0
	1857.5	26115	15	16QAM	36	37	11.05	0-2	0
1857.5	26115	15	16QAM	75	0	11.14	0-2	0	
Mid	1882.5	26365	15	QPSK	1	0	10.62	0	0
	1882.5	26365	15	QPSK	1	36	11.10	0	0
	1882.5	26365	15	QPSK	1	74	10.90	0	0
	1882.5	26365	15	QPSK	36	0	10.72	0-1	0
	1882.5	26365	15	QPSK	36	18	10.63	0-1	0
	1882.5	26365	15	QPSK	36	37	11.09	0-1	0
	1882.5	26365	15	QPSK	75	0	11.03	0-1	0
	1882.5	26365	15	16QAM	1	0	10.57	0-1	0
	1882.5	26365	15	16QAM	1	36	10.78	0-1	0
	1882.5	26365	15	16QAM	1	74	11.18	0-1	0
	1882.5	26365	15	16QAM	36	0	10.59	0-2	0
	1882.5	26365	15	16QAM	36	18	11.07	0-2	0
1882.5	26365	15	16QAM	36	37	11.09	0-2	0	
1882.5	26365	15	16QAM	75	0	10.99	0-2	0	
High	1907.5	26615	15	QPSK	1	0	10.63	0	0
	1907.5	26615	15	QPSK	1	36	10.81	0	0
	1907.5	26615	15	QPSK	1	74	11.15	0	0
	1907.5	26615	15	QPSK	36	0	10.84	0-1	0
	1907.5	26615	15	QPSK	36	18	10.94	0-1	0
	1907.5	26615	15	QPSK	36	37	11.59	0-1	0
	1907.5	26615	15	QPSK	75	0	11.00	0-1	0
	1907.5	26615	15	16QAM	1	0	10.98	0-1	0
	1907.5	26615	15	16QAM	1	36	10.90	0-1	0
	1907.5	26615	15	16QAM	1	74	11.13	0-1	0
	1907.5	26615	15	16QAM	36	0	10.95	0-2	0
	1907.5	26615	15	16QAM	36	18	11.11	0-2	0
1907.5	26615	15	16QAM	36	37	11.50	0-2	0	
1907.5	26615	15	16QAM	75	0	10.93	0-2	0	



FCC ID: ACJ9TGWW13B	 PCTEST ENGINEERING LABORATORY, INC.	SAR EVALUATION REPORT		Reviewed by: Quality Manager
Document S/N: OY1412152300.ACJ	Test Dates: 12/15/14 - 01/08/15	DUT Type: Wireless Module		Page 54 of 91

Table 8-43
LTE Band 25 (PCS) Conducted Powers – 10 MHz Bandwidth

	Frequency [MHz]	Channel	Bandwidth [MHz]	Modulation	RB Size	RB Offset	Conducted Power [dBm]	MPR Allowed per 3GPP [dB]	MPR [dB]
Low	1855	26090	10	QPSK	1	0	11.19	0	0
	1855	26090	10	QPSK	1	25	11.58	0	0
	1855	26090	10	QPSK	1	49	11.10	0	0
	1855	26090	10	QPSK	25	0	11.02	0-1	0
	1855	26090	10	QPSK	25	12	10.92	0-1	0
	1855	26090	10	QPSK	25	25	11.13	0-1	0
	1855	26090	10	QPSK	50	0	10.88	0-1	0
	1855	26090	10	16QAM	1	0	11.33	0-1	0
	1855	26090	10	16QAM	1	25	11.48	0-1	0
	1855	26090	10	16QAM	1	49	10.90	0-1	0
	1855	26090	10	16QAM	25	0	11.39	0-2	0
	1855	26090	10	16QAM	25	12	11.60	0-2	0
Mid	1882.5	26365	10	QPSK	1	0	10.58	0	0
	1882.5	26365	10	QPSK	1	25	11.05	0	0
	1882.5	26365	10	QPSK	1	49	10.95	0	0
	1882.5	26365	10	QPSK	25	0	10.67	0-1	0
	1882.5	26365	10	QPSK	25	12	10.61	0-1	0
	1882.5	26365	10	QPSK	25	25	11.11	0-1	0
	1882.5	26365	10	QPSK	50	0	10.99	0-1	0
	1882.5	26365	10	16QAM	1	0	10.54	0-1	0
	1882.5	26365	10	16QAM	1	25	10.78	0-1	0
	1882.5	26365	10	16QAM	1	49	11.16	0-1	0
	1882.5	26365	10	16QAM	25	0	10.58	0-2	0
	1882.5	26365	10	16QAM	25	12	11.09	0-2	0
High	1910	26640	10	QPSK	1	0	10.61	0	0
	1910	26640	10	QPSK	1	25	10.84	0	0
	1910	26640	10	QPSK	1	49	11.18	0	0
	1910	26640	10	QPSK	25	0	10.79	0-1	0
	1910	26640	10	QPSK	25	12	10.95	0-1	0
	1910	26640	10	QPSK	25	25	11.60	0-1	0
	1910	26640	10	QPSK	50	0	10.99	0-1	0
	1910	26640	10	16QAM	1	0	11.03	0-1	0
	1910	26640	10	16QAM	1	25	10.87	0-1	0
	1910	26640	10	16QAM	1	49	11.11	0-1	0
	1910	26640	10	16QAM	25	0	10.92	0-2	0
	1910	26640	10	16QAM	25	12	11.12	0-2	0
1910	26640	10	16QAM	25	25	11.48	0-2	0	
1910	26640	10	16QAM	50	0	10.93	0-2	0	





FCC ID: ACJ9TGWW13B	 PCTEST ENGINEERING LABORATORY, INC.	SAR EVALUATION REPORT		Reviewed by: Quality Manager
Document S/N: OY1412152300.ACJ	Test Dates: 12/15/14 - 01/08/15	DUT Type: Wireless Module		Page 55 of 91



Table 8-44
LTE Band 25 (PCS) Conducted Powers – 5 MHz Bandwidth

	Frequency [MHz]	Channel	Bandwidth [MHz]	Modulation	RB Size	RB Offset	Conducted Power [dBm]	MPR Allowed per 3GPP [dB]	MPR [dB]
Low	1852.5	26065	5	QPSK	1	0	11.21	0	0
	1852.5	26065	5	QPSK	1	12	11.61	0	0
	1852.5	26065	5	QPSK	1	24	11.09	0	0
	1852.5	26065	5	QPSK	12	0	11.03	0-1	0
	1852.5	26065	5	QPSK	12	6	10.94	0-1	0
	1852.5	26065	5	QPSK	12	13	11.18	0-1	0
	1852.5	26065	5	QPSK	25	0	10.91	0-1	0
	1852.5	26065	5	16-QAM	1	0	11.33	0-1	0
	1852.5	26065	5	16-QAM	1	12	11.51	0-1	0
	1852.5	26065	5	16-QAM	1	24	10.86	0-1	0
	1852.5	26065	5	16-QAM	12	0	11.40	0-2	0
	1852.5	26065	5	16-QAM	12	6	11.65	0-2	0
1852.5	26065	5	16-QAM	12	13	11.02	0-2	0	
1852.5	26065	5	16-QAM	25	0	11.12	0-2	0	
Mid	1882.5	26365	5	QPSK	1	0	10.61	0	0
	1882.5	26365	5	QPSK	1	12	11.02	0	0
	1882.5	26365	5	QPSK	1	24	10.91	0	0
	1882.5	26365	5	QPSK	12	0	10.65	0-1	0
	1882.5	26365	5	QPSK	12	6	10.64	0-1	0
	1882.5	26365	5	QPSK	12	13	11.07	0-1	0
	1882.5	26365	5	QPSK	25	0	11.00	0-1	0
	1882.5	26365	5	16-QAM	1	0	10.53	0-1	0
	1882.5	26365	5	16-QAM	1	12	10.83	0-1	0
	1882.5	26365	5	16-QAM	1	24	11.15	0-1	0
	1882.5	26365	5	16-QAM	12	0	10.53	0-2	0
	1882.5	26365	5	16-QAM	12	6	11.05	0-2	0
1882.5	26365	5	16-QAM	12	13	11.07	0-2	0	
1882.5	26365	5	16-QAM	25	0	10.99	0-2	0	
High	1912.5	26665	5	QPSK	1	0	10.61	0	0
	1912.5	26665	5	QPSK	1	12	10.82	0	0
	1912.5	26665	5	QPSK	1	24	11.21	0	0
	1912.5	26665	5	QPSK	12	0	10.81	0-1	0
	1912.5	26665	5	QPSK	12	6	10.94	0-1	0
	1912.5	26665	5	QPSK	12	13	11.57	0-1	0
	1912.5	26665	5	QPSK	25	0	11.01	0-1	0
	1912.5	26665	5	16-QAM	1	0	11.02	0-1	0
	1912.5	26665	5	16-QAM	1	12	10.82	0-1	0
	1912.5	26665	5	16-QAM	1	24	11.13	0-1	0
	1912.5	26665	5	16-QAM	12	0	10.96	0-2	0
	1912.5	26665	5	16-QAM	12	6	11.07	0-2	0
1912.5	26665	5	16-QAM	12	13	11.50	0-2	0	
1912.5	26665	5	16-QAM	25	0	10.95	0-2	0	

FCC ID: ACJ9TGWW13B	 PCTEST ENGINEERING LABORATORY, INC.	SAR EVALUATION REPORT		Reviewed by: Quality Manager
Document S/N: OY1412152300.ACJ	Test Dates: 12/15/14 - 01/08/15	DUT Type: Wireless Module	Page 56 of 91	



**Table 8-45
LTE Band 25 (PCS) Conducted Powers – 3 MHz Bandwidth**

	Frequency [MHz]	Channel	Bandwidth [MHz]	Modulation	RB Size	RB Offset	Conducted Power [dBm]	MPR Allowed per 3GPP [dB]	MPR [dB]
Low	1851.5	26055	3	QPSK	1	0	11.24	0	0
	1851.5	26055	3	QPSK	1	7	11.60	0	0
	1851.5	26055	3	QPSK	1	14	11.11	0	0
	1851.5	26055	3	QPSK	8	0	11.08	0-1	0
	1851.5	26055	3	QPSK	8	4	10.95	0-1	0
	1851.5	26055	3	QPSK	8	7	11.19	0-1	0
	1851.5	26055	3	QPSK	15	0	10.87	0-1	0
	1851.5	26055	3	16-QAM	1	0	11.29	0-1	0
	1851.5	26055	3	16-QAM	1	7	11.54	0-1	0
	1851.5	26055	3	16-QAM	1	14	10.83	0-1	0
	1851.5	26055	3	16-QAM	8	0	11.41	0-2	0
	1851.5	26055	3	16-QAM	8	4	11.62	0-2	0
1851.5	26055	3	16-QAM	8	7	11.06	0-2	0	
1851.5	26055	3	16-QAM	15	0	11.08	0-2	0	
Mid	1882.5	26365	3	QPSK	1	0	10.56	0	0
	1882.5	26365	3	QPSK	1	7	11.03	0	0
	1882.5	26365	3	QPSK	1	14	10.91	0	0
	1882.5	26365	3	QPSK	8	0	10.61	0-1	0
	1882.5	26365	3	QPSK	8	4	10.62	0-1	0
	1882.5	26365	3	QPSK	8	7	11.11	0-1	0
	1882.5	26365	3	QPSK	15	0	10.99	0-1	0
	1882.5	26365	3	16-QAM	1	0	10.53	0-1	0
	1882.5	26365	3	16-QAM	1	7	10.86	0-1	0
	1882.5	26365	3	16-QAM	1	14	11.14	0-1	0
	1882.5	26365	3	16-QAM	8	0	10.55	0-2	0
	1882.5	26365	3	16-QAM	8	4	11.08	0-2	0
1882.5	26365	3	16-QAM	8	7	11.03	0-2	0	
1882.5	26365	3	16-QAM	15	0	11.01	0-2	0	
High	1913.5	26675	3	QPSK	1	0	10.60	0	0
	1913.5	26675	3	QPSK	1	7	10.85	0	0
	1913.5	26675	3	QPSK	1	14	11.26	0	0
	1913.5	26675	3	QPSK	8	0	10.83	0-1	0
	1913.5	26675	3	QPSK	8	4	10.91	0-1	0
	1913.5	26675	3	QPSK	8	7	11.53	0-1	0
	1913.5	26675	3	QPSK	15	0	10.99	0-1	0
	1913.5	26675	3	16-QAM	1	0	11.05	0-1	0
	1913.5	26675	3	16-QAM	1	7	10.85	0-1	0
	1913.5	26675	3	16-QAM	1	14	11.11	0-1	0
	1913.5	26675	3	16-QAM	8	0	11.01	0-2	0
	1913.5	26675	3	16-QAM	8	4	11.06	0-2	0
1913.5	26675	3	16-QAM	8	7	11.46	0-2	0	
1913.5	26675	3	16-QAM	15	0	10.91	0-2	0	

FCC ID: ACJ9TGWW13B	 PCTEST ENGINEERING LABORATORY, INC.	SAR EVALUATION REPORT		Reviewed by: Quality Manager
Document S/N: OY1412152300.ACJ	Test Dates: 12/15/14 - 01/08/15	DUT Type: Wireless Module	Page 57 of 91	

**Table 8-46
LTE Band 25 (PCS) Conducted Powers – 1.4 MHz Bandwidth**

	Frequency [MHz]	Channel	Bandwidth [MHz]	Modulation	RB Size	RB Offset	Conducted Power [dBm]	MPR Allowed per 3GPP [dB]	MPR [dB]
Low	1850.7	26047	1.4	QPSK	1	0	11.28	0	0
	1850.7	26047	1.4	QPSK	1	2	11.59	0	0
	1850.7	26047	1.4	QPSK	1	5	11.06	0	0
	1850.7	26047	1.4	QPSK	3	0	11.06	0	0
	1850.7	26047	1.4	QPSK	3	2	10.96	0	0
	1850.7	26047	1.4	QPSK	3	3	11.19	0	0
	1850.7	26047	1.4	QPSK	6	0	10.92	0-1	0
	1850.7	26047	1.4	16-QAM	1	0	11.24	0-1	0
	1850.7	26047	1.4	16-QAM	1	2	11.57	0-1	0
	1850.7	26047	1.4	16-QAM	1	5	10.81	0-1	0
	1850.7	26047	1.4	16-QAM	3	0	11.39	0-1	0
	1850.7	26047	1.4	16-QAM	3	2	11.67	0-1	0
	1850.7	26047	1.4	16-QAM	3	3	11.11	0-1	0
1850.7	26047	1.4	16-QAM	6	0	11.03	0-2	0	
Mid	1882.5	26365	1.4	QPSK	1	0	10.54	0	0
	1882.5	26365	1.4	QPSK	1	2	11.06	0	0
	1882.5	26365	1.4	QPSK	1	5	10.94	0	0
	1882.5	26365	1.4	QPSK	3	0	10.66	0	0
	1882.5	26365	1.4	QPSK	3	2	10.58	0	0
	1882.5	26365	1.4	QPSK	3	3	11.13	0	0
	1882.5	26365	1.4	QPSK	6	0	10.97	0-1	0
	1882.5	26365	1.4	16-QAM	1	0	10.55	0-1	0
	1882.5	26365	1.4	16-QAM	1	2	10.89	0-1	0
	1882.5	26365	1.4	16-QAM	1	5	11.12	0-1	0
	1882.5	26365	1.4	16-QAM	3	0	10.60	0-1	0
	1882.5	26365	1.4	16-QAM	3	2	11.08	0-1	0
	1882.5	26365	1.4	16-QAM	3	3	11.07	0-1	0
1882.5	26365	1.4	16-QAM	6	0	11.02	0-2	0	
High	1914.3	26683	1.4	QPSK	1	0	10.60	0	0
	1914.3	26683	1.4	QPSK	1	2	10.89	0	0
	1914.3	26683	1.4	QPSK	1	5	11.30	0	0
	1914.3	26683	1.4	QPSK	3	0	10.87	0	0
	1914.3	26683	1.4	QPSK	3	2	10.89	0	0
	1914.3	26683	1.4	QPSK	3	3	11.53	0	0
	1914.3	26683	1.4	QPSK	6	0	11.01	0-1	0
	1914.3	26683	1.4	16-QAM	1	0	11.08	0-1	0
	1914.3	26683	1.4	16-QAM	1	2	10.82	0-1	0
	1914.3	26683	1.4	16-QAM	1	5	11.11	0-1	0
	1914.3	26683	1.4	16-QAM	3	0	11.05	0-1	0
	1914.3	26683	1.4	16-QAM	3	2	11.06	0-1	0
	1914.3	26683	1.4	16-QAM	3	3	11.41	0-1	0
1914.3	26683	1.4	16-QAM	6	0	10.91	0-2	0	

FCC ID: ACJ9TGWW13B	 PCTEST ENGINEERING LABORATORY, INC.	SAR EVALUATION REPORT		Reviewed by: Quality Manager
Document S/N: OY1412152300.ACJ	Test Dates: 12/15/14 - 01/08/15	DUT Type: Wireless Module		Page 58 of 91

9



SYSTEM VERIFICATION

9.1 Tissue Verification

**Table 9-1
Measured Tissue Properties**

Calibrated for Tests Performed on:	Tissue Type	Tissue Temp During Calibration (C°)	Measured Frequency (MHz)	Measured Conductivity, σ (S/m)	Measured Dielectric Constant, ϵ	TARGET Conductivity, σ (S/m)	TARGET Dielectric Constant, ϵ	% dev σ	% dev ϵ
12/16/2014	750B	21.8	710	0.921	54.356	0.960	55.687	-4.06%	-2.39%
			725	0.935	54.244	0.961	55.629	-2.71%	-2.49%
			740	0.949	54.104	0.963	55.570	-1.45%	-2.64%
			755	0.963	53.942	0.964	55.512	-0.10%	-2.83%
			770	0.977	53.750	0.965	55.453	1.24%	-3.07%
12/16/2014	835B	22.0	820	0.988	53.732	0.969	55.258	1.96%	-2.76%
			835	1.003	53.638	0.970	55.200	3.40%	-2.83%
			850	1.017	53.528	0.988	55.154	2.94%	-2.95%
12/20/2014	835B	21.1	820	0.986	55.536	0.969	55.258	1.75%	0.50%
			835	1.000	55.317	0.970	55.200	3.09%	0.21%
			850	1.013	55.147	0.988	55.154	2.53%	-0.01%
01/05/2015	835B	21.1	820	1.001	53.781	0.969	55.258	3.30%	-2.67%
			835	1.016	53.636	0.970	55.200	4.74%	-2.83%
			850	1.030	53.458	0.988	55.154	4.25%	-3.08%
12/17/2014	1750B	23.0	1710	1.424	51.578	1.463	53.537	-2.67%	-3.66%
			1750	1.469	51.413	1.488	53.432	-1.28%	-3.78%
			1790	1.512	51.266	1.514	53.326	-0.13%	-3.86%
12/22/2014	1750B	21.6	1710	1.497	52.186	1.463	53.537	2.32%	-2.52%
			1750	1.543	52.013	1.488	53.432	3.70%	-2.66%
			1790	1.587	51.837	1.514	53.326	4.82%	-2.79%
12/15/2014	1900B	20.0	1850	1.495	52.815	1.520	53.300	-1.64%	-0.91%
			1880	1.531	52.753	1.520	53.300	0.72%	-1.03%
			1910	1.565	52.639	1.520	53.300	2.96%	-1.24%
12/19/2014	1900B	22.2	1850	1.517	52.415	1.520	53.300	-0.20%	-1.66%
			1880	1.552	52.338	1.520	53.300	2.11%	-1.80%
			1910	1.589	52.230	1.520	53.300	4.54%	-2.01%
01/08/2015	1900B	22.5	1850	1.454	52.809	1.520	53.300	-4.34%	-0.92%
			1880	1.490	52.726	1.520	53.300	-1.97%	-1.08%
			1910	1.528	52.675	1.520	53.300	0.53%	-1.17%

The above measured tissue parameters were used in the DASY software. The DASY software was used to perform interpolation to determine the dielectric parameters at the SAR test device frequencies (per KDB Publication 865664 and IEEE 1528-2013 6.6.1.2). The tissue parameters listed in the SAR test plots may slightly differ from the table above due to significant digit rounding in the software.

FCC ID: ACJ9TGWW13B	 PCTEST ENGINEERING LABORATORY, INC.	SAR EVALUATION REPORT		Reviewed by: Quality Manager
Document S/N: OY1412152300.ACJ	Test Dates: 12/15/14 - 01/08/15	DUT Type: Wireless Module		Page 59 of 91

9.2 Test System Verification

Prior to SAR assessment, the system is verified to $\pm 10\%$ of the SAR measurement on the reference dipole at the time of calibration by the calibration facility. Full system validation status and result summary can be found in Appendix E.

**Table 9-2
System Verification Results**

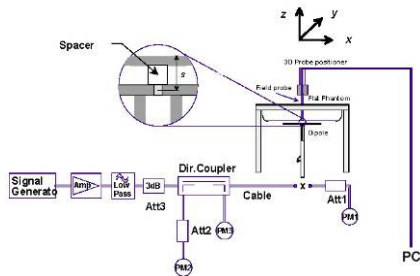

System Verification TARGET & MEASURED												
SAR System #	Tissue Frequency (MHz)	Tissue Type	Date:	Amb. Temp (°C)	Liquid Temp (°C)	Input Power (W)	Dipole SN	Probe SN	Measured SAR _{1g} (W/kg)	1 W Target SAR _{1g} (W/kg)	1 W Normalized SAR _{1g} (W/kg)	Deviation _{1g} (%)
G	750	BODY	12/16/2014	24.5	22.0	0.100	1054	3258	0.871	8.640	8.710	0.81%
K	835	BODY	12/16/2014	23.3	22.0	0.100	4d119	3288	0.984	9.340	9.840	5.35%
K	835	BODY	12/20/2014	21.1	21.1	0.100	4d133	3288	0.967	9.350	9.670	3.42%
K	835	BODY	01/05/2015	23.4	22.1	0.100	4d119	3288	0.972	9.340	9.720	4.07%
J	1750	BODY	12/17/2014	22.0	21.0	0.100	1008	3022	3.810	37.600	38.100	1.33%
G	1750	BODY	12/22/2014	23.6	21.8	0.100	1008	3258	3.690	37.600	36.900	-1.86%
I	1900	BODY	12/15/2014	21.3	20.0	0.100	5d141	3209	4.000	40.600	40.000	-1.48%
I	1900	BODY	12/19/2014	24.5	22.2	0.100	5d141	3209	4.260	40.600	42.600	4.93%
G	1900	BODY	01/08/2015	23.6	22.5	0.100	5d141	3258	4.050	40.600	40.500	-0.25%



**Figure 9-1
System Verification Setup Diagram**



**Figure 9-2
System Verification Setup Photo**



FCC ID: ACJ9TGWW13B	 PCTEST ENGINEERING LABORATORY, INC.	SAR EVALUATION REPORT		Reviewed by: Quality Manager
Document S/N: OY1412152300.ACJ	Test Dates: 12/15/14 - 01/08/15	DUT Type: Wireless Module		Page 60 of 91

10 SAR DATA SUMMARY

10.1 Standalone Body SAR Data

Table 10-1
GPRS Body SAR Data



MEASUREMENT RESULTS																
FREQUENCY		Mode	Service	Maximum Allowed Power [dBm]	Conducted Power [dBm]	Power Drift [dB]	Spacing	Device Serial Number	# of GPRS Slots	Duty Cycle	Side	Orientation	SAR (1g)	Scaling Factor	Scaled SAR (1g)	Plot #
MHz	Ch.												(W/kg)		(W/kg)	
836.60	190	GSM 850	GPRS	33.5	31.93	0.05	18 mm	SAR-4	2	1.4.15	back	Perpendicular	0.381	1.435	0.547	
836.60	190	GSM 850	GPRS	33.5	31.93	-0.02	16 mm	SAR-4	2	1.4.15	top	Perpendicular	0.240	1.435	0.344	
836.60	190	GSM 850	GPRS	33.5	31.93	-0.13	16 mm	SAR-4	2	1.4.15	top	Tilt (Top-Back Surface)	0.312	1.435	0.448	
836.60	190	GSM 850	GPRS	33.5	31.93	0.07	3 mm	SAR-4	2	1.4.15	right	Perpendicular	0.335	1.435	0.481	
824.20	128	GSM 850	GPRS	33.5	32.06	0.01	3 mm	SAR-4	2	1.4.15	right	Tilt (Right-Back Surface)	0.670	1.393	0.933	A1
836.60	190	GSM 850	GPRS	33.5	31.93	0.07	3 mm	SAR-4	2	1.4.15	right	Tilt (Right-Back Surface)	0.644	1.435	0.924	
848.80	251	GSM 850	GPRS	33.5	31.83	-0.03	3 mm	SAR-4	2	1.4.15	right	Tilt (Right-Back Surface)	0.658	1.469	0.967	
836.60	190	GSM 850	GPRS	33.5	31.93	0.00	0 mm	SAR-4	2	1.4.15	left	Perpendicular	0.146	1.435	0.210	
836.60	190	GSM 850	GPRS	33.5	31.93	0.11	0 mm	SAR-4	2	1.4.15	left	Tilt (Left-Back Surface)	0.227	1.435	0.326	
836.60	190	GSM 850	GPRS	25.0	24.19	0.15	0 mm	SAR-1	2	1.4.15	back	Perpendicular	0.378	1.205	0.455	
836.60	190	GSM 850	GPRS	25.0	24.19	-0.02	0 mm	SAR-1	2	1.4.15	top	Perpendicular	0.161	1.205	0.194	
836.60	190	GSM 850	GPRS	25.0	24.19	-0.04	0 mm	SAR-1	2	1.4.15	top	Tilt (Top-Back Surface)	0.265	1.205	0.319	
836.60	190	GSM 850	GPRS	25.0	24.19	0.12	0 mm	SAR-1	2	1.4.15	right	Perpendicular	0.050	1.205	0.060	
836.60	190	GSM 850	GPRS	25.0	24.19	0.02	0 mm	SAR-1	2	1.4.15	right	Tilt (Right-Back Surface)	0.126	1.205	0.152	
1880.00	661	GSM 1900	GPRS	30.5	29.53	0.07	18 mm	SAR-3	2	1.4.15	back	Perpendicular	0.391	1.250	0.489	
1880.00	661	GSM 1900	GPRS	30.5	29.53	-0.04	16 mm	SAR-3	2	1.4.15	top	Perpendicular	0.451	1.250	0.564	
1880.00	661	GSM 1900	GPRS	30.5	29.53	0.04	16 mm	SAR-3	2	1.4.15	top	Tilt (Top-Back Surface)	0.634	1.250	0.793	A2
1880.00	661	GSM 1900	GPRS	30.5	29.53	0.14	3 mm	SAR-3	2	1.4.15	right	Perpendicular	0.103	1.250	0.129	
1880.00	661	GSM 1900	GPRS	30.5	29.53	0.02	3 mm	SAR-3	2	1.4.15	right	Tilt (Right-Back Surface)	0.316	1.250	0.395	
1880.00	661	GSM 1900	GPRS	30.5	29.53	0.12	0 mm	SAR-3	2	1.4.15	left	Perpendicular	0.028	1.250	0.035	
1880.00	661	GSM 1900	GPRS	30.5	29.53	0.13	0 mm	SAR-3	2	1.4.15	left	Tilt (Left-Back Surface)	0.020	1.250	0.025	
1880.00	661	GSM 1900	GPRS	18.0	17.33	0.17	0 mm	SAR-3	2	1.4.15	back	Perpendicular	0.403	1.167	0.470	
1880.00	661	GSM 1900	GPRS	18.0	17.33	-0.08	0 mm	SAR-3	2	1.4.15	top	Perpendicular	0.177	1.167	0.207	
1880.00	661	GSM 1900	GPRS	18.0	17.33	-0.10	0 mm	SAR-3	2	1.4.15	top	Tilt (Top-Back Surface)	0.214	1.167	0.250	
1880.00	661	GSM 1900	GPRS	18.0	17.33	0.12	0 mm	SAR-3	2	1.4.15	right	Perpendicular	0.025	1.167	0.029	
1880.00	661	GSM 1900	GPRS	18.0	17.33	-0.04	0 mm	SAR-3	2	1.4.15	right	Tilt (Right-Back Surface)	0.066	1.167	0.077	
ANSI / IEEE C95.1 1992 - SAFETY LIMIT Spatial Peak Uncontrolled Exposure/General Population							Body 1.6 W/kg (mW/g) averaged over 1 gram									

FCC ID: ACJ9TGWW13B		SAR EVALUATION REPORT		Reviewed by: Quality Manager
Document S/N: OY1412152300.ACJ	Test Dates: 12/15/14 - 01/08/15	DUT Type: Wireless Module	Page 61 of 91	

**Table 10-2
UMTS Body SAR Data**

MEASUREMENT RESULTS															
FREQUENCY		Mode	Service	Maximum Allowed Power [dBm]	Conducted Power [dBm]	Power Drift [dB]	Spacing	Device Serial Number	Duty Cycle	Side	Orientation	SAR (1g)	Scaling Factor	Scaled SAR (1g)	Plot #
MHz	Ch.											(W/kg)		(W/kg)	
836.60	4183	UMTS 850	RMC	24.0	22.82	0.10	18 mm	SAR-4	1:1	back	Perpendicular	0.213	1.312	0.279	
836.60	4183	UMTS 850	RMC	24.0	22.82	0.12	16 mm	SAR-4	1:1	top	Perpendicular	0.141	1.312	0.185	
836.60	4183	UMTS 850	RMC	24.0	22.82	0.17	16 mm	SAR-4	1:1	top	Tilt (Top-Back Surface)	0.223	1.312	0.293	
836.60	4183	UMTS 850	RMC	24.0	22.82	-0.17	3 mm	SAR-4	1:1	right	Perpendicular	0.196	1.312	0.257	
836.60	4183	UMTS 850	RMC	24.0	22.82	0.12	3 mm	SAR-4	1:1	right	Tilt (Right-Back Surface)	0.328	1.312	0.430	
836.60	4183	UMTS 850	RMC	24.0	22.82	0.12	0 mm	SAR-4	1:1	left	Perpendicular	0.087	1.312	0.114	
836.60	4183	UMTS 850	RMC	24.0	22.82	0.13	0 mm	SAR-4	1:1	left	Tilt (Left-Back Surface)	0.130	1.312	0.171	
836.60	4183	UMTS 850	RMC	17.5	16.33	0.07	0 mm	SAR-4	1:1	back	Perpendicular	0.371	1.309	0.486	A3
836.60	4183	UMTS 850	RMC	17.5	16.33	0.05	0 mm	SAR-4	1:1	top	Perpendicular	0.152	1.309	0.199	
836.60	4183	UMTS 850	RMC	17.5	16.33	0.05	0 mm	SAR-4	1:1	top	Tilt (Top-Back Surface)	0.264	1.309	0.346	
836.60	4183	UMTS 850	RMC	17.5	16.33	-0.02	0 mm	SAR-4	1:1	right	Perpendicular	0.058	1.309	0.076	
836.60	4183	UMTS 850	RMC	17.5	16.33	0.01	0 mm	SAR-4	1:1	right	Tilt (Right-Back Surface)	0.135	1.309	0.177	
1732.40	1412	UMTS 1750	RMC	24.0	22.99	0.05	18 mm	SAR-3	1:1	back	Perpendicular	0.495	1.262	0.625	
1732.40	1412	UMTS 1750	RMC	24.0	22.99	-0.03	16 mm	SAR-3	1:1	top	Perpendicular	0.419	1.262	0.529	
1732.40	1412	UMTS 1750	RMC	24.0	22.99	-0.02	16 mm	SAR-3	1:1	top	Tilt (Top-Back Surface)	0.613	1.262	0.774	A4
1732.40	1412	UMTS 1750	RMC	24.0	22.99	-0.06	3 mm	SAR-3	1:1	right	Perpendicular	0.246	1.262	0.310	
1732.40	1412	UMTS 1750	RMC	24.0	22.99	0.04	3 mm	SAR-3	1:1	right	Tilt (Right-Back Surface)	0.385	1.262	0.486	
1732.40	1412	UMTS 1750	RMC	24.0	22.99	-0.10	0 mm	SAR-3	1:1	left	Perpendicular	0.100	1.262	0.126	
1732.40	1412	UMTS 1750	RMC	24.0	22.99	0.13	0 mm	SAR-3	1:1	left	Tilt (Left-Back Surface)	0.065	1.262	0.082	
1732.40	1412	UMTS 1750	RMC	10.0	8.65	0.00	0 mm	SAR-3	1:1	back	Perpendicular	0.364	1.365	0.497	
1732.40	1412	UMTS 1750	RMC	10.0	8.65	-0.05	0 mm	SAR-3	1:1	top	Perpendicular	0.144	1.365	0.197	
1732.40	1412	UMTS 1750	RMC	10.0	8.65	0.07	0 mm	SAR-3	1:1	top	Tilt (Top-Back Surface)	0.221	1.365	0.302	
1732.40	1412	UMTS 1750	RMC	10.0	8.65	0.07	0 mm	SAR-3	1:1	right	Perpendicular	0.026	1.365	0.035	
1732.40	1412	UMTS 1750	RMC	10.0	8.65	0.06	0 mm	SAR-3	1:1	right	Tilt (Right-Back Surface)	0.055	1.365	0.075	
1880.00	9400	UMTS 1900	RMC	24.0	23.02	0.00	18 mm	SAR-3	1:1	back	Perpendicular	0.478	1.253	0.599	
1880.00	9400	UMTS 1900	RMC	24.0	23.02	-0.10	16 mm	SAR-3	1:1	top	Perpendicular	0.516	1.253	0.647	
1852.40	9262	UMTS 1900	RMC	24.0	22.97	0.07	16 mm	SAR-3	1:1	top	Tilt (Top-Back Surface)	0.788	1.268	0.999	
1880.00	9400	UMTS 1900	RMC	24.0	23.02	-0.09	16 mm	SAR-3	1:1	top	Tilt (Top-Back Surface)	0.839	1.253	1.051	
1907.60	9538	UMTS 1900	RMC	24.0	23.11	-0.15	16 mm	SAR-3	1:1	top	Tilt (Top-Back Surface)	0.919	1.227	1.128	A5
1880.00	9400	UMTS 1900	RMC	24.0	23.02	0.00	3 mm	SAR-3	1:1	right	Perpendicular	0.089	1.253	0.112	
1880.00	9400	UMTS 1900	RMC	24.0	23.02	0.01	3 mm	SAR-3	1:1	right	Tilt (Right-Back Surface)	0.228	1.253	0.286	
1880.00	9400	UMTS 1900	RMC	24.0	23.02	0.14	0 mm	SAR-3	1:1	left	Perpendicular	0.013	1.253	0.016	
1880.00	9400	UMTS 1900	RMC	24.0	23.02	0.16	0 mm	SAR-3	1:1	left	Tilt (Left-Back Surface)	0.034	1.253	0.043	
1880.00	9400	UMTS 1900	RMC	11.5	10.33	-0.03	0 mm	SAR-3	1:1	back	Perpendicular	0.463	1.309	0.606	
1880.00	9400	UMTS 1900	RMC	11.5	10.33	-0.02	0 mm	SAR-3	1:1	top	Perpendicular	0.176	1.309	0.230	
1880.00	9400	UMTS 1900	RMC	11.5	10.33	0.04	0 mm	SAR-3	1:1	top	Tilt (Top-Back Surface)	0.290	1.309	0.380	
1880.00	9400	UMTS 1900	RMC	11.5	10.33	0.13	0 mm	SAR-3	1:1	right	Perpendicular	0.013	1.309	0.017	
1880.00	9400	UMTS 1900	RMC	11.5	10.33	0.12	0 mm	SAR-3	1:1	right	Tilt (Right-Back Surface)	0.025	1.309	0.033	
1907.60	9538	UMTS 1900	RMC	24.0	23.11	-0.05	16 mm	SAR-3	1:1	top	Tilt (Top-Back Surface)	0.913	1.227	1.120	
ANSI / IEEE C95.1 1992 - SAFETY LIMIT Spatial Peak Uncontrolled Exposure/General Population							Body 1.6 W/kg (mW/g) averaged over 1 gram								



Note: Blue entry represents variability.

FCC ID: ACJ9TGWW13B		SAR EVALUATION REPORT		Reviewed by: Quality Manager
Document S/N: OY1412152300.ACJ	Test Dates: 12/15/14 - 01/08/15	DUT Type: Wireless Module		Page 62 of 91

**Table 10-3
EVDO Body SAR Data**



MEASUREMENT RESULTS															
FREQUENCY		Mode	Service	Maximum Allowed Power [dBm]	Conducted Power [dBm]	Power Drift [dB]	Spacing	Device Serial Number	Duty Cycle	Side	Orientation	SAR (1g)	Scaling Factor	Scaled SAR (1g)	Plot #
MHz	Ch.											(W/kg)		(W/kg)	
820.10	564	CDMA BC10 (§90S)	EVDO Rev. 0	25.0	23.95	0.07	18 mm	SAR-3	1:1	back	Perpendicular	0.288	1.274	0.367	
820.10	564	CDMA BC10 (§90S)	EVDO Rev. 0	25.0	23.95	0.05	16 mm	SAR-3	1:1	top	Perpendicular	0.134	1.274	0.171	
820.10	564	CDMA BC10 (§90S)	EVDO Rev. 0	25.0	23.95	-0.19	16 mm	SAR-3	1:1	top	Tilt (Top-Back Surface)	0.249	1.274	0.317	
820.10	564	CDMA BC10 (§90S)	EVDO Rev. 0	25.0	23.95	0.04	3 mm	SAR-3	1:1	right	Perpendicular	0.063	1.274	0.080	
820.10	564	CDMA BC10 (§90S)	EVDO Rev. 0	25.0	23.95	0.03	3 mm	SAR-3	1:1	right	Tilt (Right-Back Surface)	0.093	1.274	0.118	
820.10	564	CDMA BC10 (§90S)	EVDO Rev. 0	25.0	23.95	0.06	0 mm	SAR-3	1:1	left	Perpendicular	0.104	1.274	0.132	
820.10	564	CDMA BC10 (§90S)	EVDO Rev. 0	25.0	23.95	0.13	0 mm	SAR-3	1:1	left	Tilt (Left-Back Surface)	0.158	1.274	0.201	
820.10	564	CDMA BC10 (§90S)	EVDO Rev. 0	18.0	16.78	-0.01	0 mm	SAR-3	1:1	back	Perpendicular	0.477	1.324	0.632	A6
820.10	564	CDMA BC10 (§90S)	EVDO Rev. 0	18.0	16.78	0.02	0 mm	SAR-3	1:1	top	Perpendicular	0.161	1.324	0.213	
820.10	564	CDMA BC10 (§90S)	EVDO Rev. 0	18.0	16.78	-0.06	0 mm	SAR-3	1:1	top	Tilt (Top-Back Surface)	0.259	1.324	0.343	
820.10	564	CDMA BC10 (§90S)	EVDO Rev. 0	18.0	16.78	0.04	0 mm	SAR-3	1:1	right	Perpendicular	0.082	1.324	0.109	
820.10	564	CDMA BC10 (§90S)	EVDO Rev. 0	18.0	16.78	-0.08	0 mm	SAR-3	1:1	right	Tilt (Right-Back Surface)	0.156	1.324	0.207	
836.52	384	CDMA BC0 (§22H)	EVDO Rev. 0	25.0	23.82	0.04	18 mm	SAR-3	1:1	back	Perpendicular	0.310	1.312	0.407	
836.52	384	CDMA BC0 (§22H)	EVDO Rev. 0	25.0	23.82	-0.02	16 mm	SAR-3	1:1	top	Perpendicular	0.167	1.312	0.219	
836.52	384	CDMA BC0 (§22H)	EVDO Rev. 0	25.0	23.82	-0.05	16 mm	SAR-3	1:1	top	Tilt (Top-Back Surface)	0.304	1.312	0.399	
836.52	384	CDMA BC0 (§22H)	EVDO Rev. 0	25.0	23.82	0.09	3 mm	SAR-3	1:1	right	Perpendicular	0.054	1.312	0.071	
836.52	384	CDMA BC0 (§22H)	EVDO Rev. 0	25.0	23.82	0.09	3 mm	SAR-3	1:1	right	Tilt (Right-Back Surface)	0.084	1.312	0.110	
836.52	384	CDMA BC0 (§22H)	EVDO Rev. 0	25.0	23.82	0.01	0 mm	SAR-3	1:1	left	Perpendicular	0.106	1.312	0.139	
836.52	384	CDMA BC0 (§22H)	EVDO Rev. 0	25.0	23.82	0.00	0 mm	SAR-3	1:1	left	Tilt (Left-Back Surface)	0.149	1.312	0.195	
836.52	384	CDMA BC0 (§22H)	EVDO Rev. 0	18.0	16.98	0.03	0 mm	SAR-3	1:1	back	Perpendicular	0.553	1.265	0.700	A7
836.52	384	CDMA BC0 (§22H)	EVDO Rev. 0	18.0	16.98	-0.05	0 mm	SAR-3	1:1	top	Perpendicular	0.191	1.265	0.242	
836.52	384	CDMA BC0 (§22H)	EVDO Rev. 0	18.0	16.98	0.02	0 mm	SAR-3	1:1	top	Tilt (Top-Back Surface)	0.335	1.265	0.424	
836.52	384	CDMA BC0 (§22H)	EVDO Rev. 0	18.0	16.98	0.04	0 mm	SAR-3	1:1	right	Perpendicular	0.076	1.265	0.096	
836.52	384	CDMA BC0 (§22H)	EVDO Rev. 0	18.0	16.98	0.03	0 mm	SAR-3	1:1	right	Tilt (Right-Back Surface)	0.149	1.265	0.188	
1851.25	25	PCS CDMA	EVDO Rev. 0	25.0	24.11	-0.02	18 mm	SAR-3	1:1	back	Perpendicular	0.557	1.227	0.683	
1880.00	600	PCS CDMA	EVDO Rev. 0	25.0	23.89	-0.05	18 mm	SAR-3	1:1	back	Perpendicular	0.658	1.291	0.849	
1908.75	1175	PCS CDMA	EVDO Rev. 0	25.0	24.09	-0.07	18 mm	SAR-3	1:1	back	Perpendicular	0.572	1.233	0.705	
1880.00	600	PCS CDMA	EVDO Rev. 0	25.0	23.89	-0.04	16 mm	SAR-3	1:1	top	Perpendicular	0.561	1.291	0.724	
1851.25	25	PCS CDMA	EVDO Rev. 0	25.0	24.11	0.03	16 mm	SAR-3	1:1	top	Tilt (Top-Back Surface)	0.769	1.227	0.944	
1880.00	600	PCS CDMA	EVDO Rev. 0	25.0	23.89	-0.03	16 mm	SAR-3	1:1	top	Tilt (Top-Back Surface)	0.790	1.291	1.020	
1908.75	1175	PCS CDMA	EVDO Rev. 0	25.0	24.09	0.01	16 mm	SAR-3	1:1	top	Tilt (Top-Back Surface)	0.834	1.233	1.028	A8
1880.00	600	PCS CDMA	EVDO Rev. 0	25.0	23.89	0.05	3 mm	SAR-3	1:1	right	Perpendicular	0.204	1.291	0.263	
1880.00	600	PCS CDMA	EVDO Rev. 0	25.0	23.89	-0.08	3 mm	SAR-3	1:1	right	Tilt (Right-Back Surface)	0.319	1.291	0.412	
1880.00	600	PCS CDMA	EVDO Rev. 0	25.0	23.89	0.16	0 mm	SAR-3	1:1	left	Perpendicular	0.040	1.291	0.052	
1880.00	600	PCS CDMA	EVDO Rev. 0	25.0	23.89	-0.12	0 mm	SAR-3	1:1	left	Tilt (Left-Back Surface)	0.023	1.291	0.030	
1880.00	600	PCS CDMA	EVDO Rev. 0	11.5	10.38	-0.09	0 mm	SAR-3	1:1	back	Perpendicular	0.429	1.294	0.555	
1880.00	600	PCS CDMA	EVDO Rev. 0	11.5	10.38	-0.05	0 mm	SAR-3	1:1	top	Perpendicular	0.195	1.294	0.252	
1880.00	600	PCS CDMA	EVDO Rev. 0	11.5	10.38	0.05	0 mm	SAR-3	1:1	top	Tilt (Top-Back Surface)	0.231	1.294	0.299	
1880.00	600	PCS CDMA	EVDO Rev. 0	11.5	10.38	0.12	0 mm	SAR-3	1:1	right	Perpendicular	0.012	1.294	0.016	
1880.00	600	PCS CDMA	EVDO Rev. 0	11.5	10.38	0.04	0 mm	SAR-3	1:1	right	Tilt (Right-Back Surface)	0.025	1.294	0.032	

ANSI / IEEE C95.1 1992 - SAFETY LIMIT Spatial Peak Uncontrolled Exposure/General Population	Body 1.6 W/kg (mW/g) averaged over 1 gram
---	---

FCC ID: ACJ9TGWW13B	 SAR EVALUATION REPORT		Reviewed by: Quality Manager
Document S/N: OY1412152300.ACJ	Test Dates: 12/15/14 - 01/08/15	DUT Type: Wireless Module	Page 63 of 91



**Table 10-4
LTE Band 17 Body SAR Data**

MEASUREMENT RESULTS																				
FREQUENCY		Mode	Bandwidth [MHz]	Maximum Allowed Power [dBm]	Conducted Power [dBm]	Power Drift [dB]	MPR [dB]	Device Serial Number	Modulation	RB Size	RB Offset	Spacing	Side	Orientation	Duty Cycle	SAR (1g) (W/kg)	Scaling Factor	Scaled SAR (1g) (W/kg)	Plot #	
MHz	Ch.																			
710.00	23790	Md	LTE Band 17	10	24.0	22.69	-0.13	0	SAR-5	QPSK	1	49	18 mm	back	Perpendicular	1:1	0.198	1.352	0.268	
710.00	23790	Md	LTE Band 17	10	23.0	21.72	0.17	1	SAR-5	QPSK	25	12	18 mm	back	Perpendicular	1:1	0.177	1.343	0.238	
710.00	23790	Md	LTE Band 17	10	24.0	22.69	0.19	0	SAR-5	QPSK	1	49	16 mm	top	Perpendicular	1:1	0.158	1.352	0.214	
710.00	23790	Md	LTE Band 17	10	23.0	21.72	0.10	1	SAR-5	QPSK	25	12	16 mm	top	Perpendicular	1:1	0.152	1.343	0.204	
710.00	23790	Md	LTE Band 17	10	24.0	22.69	-0.08	0	SAR-5	QPSK	1	49	16 mm	top	Tilt (Top-Back Surface)	1:1	0.120	1.352	0.162	
710.00	23790	Md	LTE Band 17	10	23.0	21.72	0.10	1	SAR-5	QPSK	25	12	16 mm	top	Tilt (Top-Back Surface)	1:1	0.107	1.343	0.144	
710.00	23790	Md	LTE Band 17	10	24.0	22.69	0.06	0	SAR-5	QPSK	1	49	3 mm	right	Perpendicular	1:1	0.189	1.352	0.256	
710.00	23790	Md	LTE Band 17	10	23.0	21.72	0.06	1	SAR-5	QPSK	25	12	3 mm	right	Perpendicular	1:1	0.169	1.343	0.227	
710.00	23790	Md	LTE Band 17	10	24.0	22.69	0.10	0	SAR-5	QPSK	1	49	3 mm	right	Tilt (Right-Back Surface)	1:1	0.241	1.352	0.326	
710.00	23790	Md	LTE Band 17	10	23.0	21.72	0.07	1	SAR-5	QPSK	25	12	3 mm	right	Tilt (Right-Back Surface)	1:1	0.207	1.343	0.278	
710.00	23790	Md	LTE Band 17	10	24.0	22.69	-0.21	0	SAR-5	QPSK	1	49	0 mm	left	Perpendicular	1:1	0.076	1.352	0.103	
710.00	23790	Md	LTE Band 17	10	23.0	21.72	-0.16	1	SAR-5	QPSK	25	12	0 mm	left	Perpendicular	1:1	0.049	1.343	0.066	
710.00	23790	Md	LTE Band 17	10	24.0	22.69	-0.13	0	SAR-5	QPSK	1	49	0 mm	left	Tilt (Left-Back Surface)	1:1	0.094	1.352	0.127	
710.00	23790	Md	LTE Band 17	10	23.0	21.72	-0.19	1	SAR-5	QPSK	25	12	0 mm	left	Tilt (Left-Back Surface)	1:1	0.057	1.343	0.077	
710.00	23790	Md	LTE Band 17	10	17.0	15.82	-0.03	0	SAR-5	QPSK	1	49	0 mm	back	Perpendicular	1:1	0.288	1.312	0.378	
710.00	23790	Md	LTE Band 17	10	17.0	15.75	0.05	0	SAR-5	QPSK	25	25	0 mm	back	Perpendicular	1:1	0.302	1.334	0.403	A9
710.00	23790	Md	LTE Band 17	10	17.0	15.82	-0.02	0	SAR-5	QPSK	1	49	0 mm	top	Perpendicular	1:1	0.088	1.312	0.115	
710.00	23790	Md	LTE Band 17	10	17.0	15.75	0.11	0	SAR-5	QPSK	25	25	0 mm	top	Perpendicular	1:1	0.096	1.334	0.128	
710.00	23790	Md	LTE Band 17	10	17.0	15.82	0.01	0	SAR-5	QPSK	1	49	0 mm	top	Tilt (Top-Back Surface)	1:1	0.121	1.312	0.159	
710.00	23790	Md	LTE Band 17	10	17.0	15.75	0.07	0	SAR-5	QPSK	25	25	0 mm	top	Tilt (Top-Back Surface)	1:1	0.133	1.334	0.177	
710.00	23790	Md	LTE Band 17	10	17.0	15.82	0.15	0	SAR-5	QPSK	1	49	0 mm	right	Perpendicular	1:1	0.055	1.312	0.072	
710.00	23790	Md	LTE Band 17	10	17.0	15.75	-0.09	0	SAR-5	QPSK	25	25	0 mm	right	Perpendicular	1:1	0.053	1.334	0.071	
710.00	23790	Md	LTE Band 17	10	17.0	15.82	0.02	0	SAR-5	QPSK	1	49	0 mm	right	Tilt (Right-Back Surface)	1:1	0.086	1.312	0.113	
710.00	23790	Md	LTE Band 17	10	17.0	15.75	0.01	0	SAR-5	QPSK	25	25	0 mm	right	Tilt (Right-Back Surface)	1:1	0.086	1.334	0.115	
ANSI / IEEE C95.1 1992 - SAFETY LIMIT Spatial Peak Uncontrolled Exposure/General Population										Body 1.6 W/kg (mW/g) averaged over 1 gram										

FCC ID: ACJ9TGWW13B	 PCTEST ENGINEERING LABORATORY, INC.	SAR EVALUATION REPORT		Reviewed by: Quality Manager
Document S/N: OY1412152300.ACJ	Test Dates: 12/15/14 - 01/08/15	DUT Type: Wireless Module		Page 64 of 91



**Table 10-5
LTE Band 13 Body SAR Data**

MEASUREMENT RESULTS																				
FREQUENCY		Mode	Bandwidth [MHz]	Maximum Allowed Power [dBm]	Conducted Power [dBm]	Power Drift [dB]	MPR [dB]	Device Serial Number	Modulation	RB Size	RB Offset	Spacing	Side	Orientation	Duty Cycle	SAR (1g) (W/kg)	Scaling Factor	Scaled SAR (1g) (W/kg)	Plot #	
MHz	Ch.																			
782.00	23230	Mid	LTE Band 13	10	24.0	23.02	0.02	0	SAR-5	QPSK	1	49	18 mm	back	Perpendicular	1:1	0.234	1.253	0.293	
782.00	23230	Mid	LTE Band 13	10	23.0	22.00	0.12	1	SAR-5	QPSK	25	12	18 mm	back	Perpendicular	1:1	0.204	1.259	0.257	
782.00	23230	Mid	LTE Band 13	10	24.0	23.02	0.08	0	SAR-5	QPSK	1	49	16 mm	top	Perpendicular	1:1	0.231	1.253	0.289	
782.00	23230	Mid	LTE Band 13	10	23.0	22.00	-0.07	1	SAR-5	QPSK	25	12	16 mm	top	Perpendicular	1:1	0.178	1.259	0.224	
782.00	23230	Mid	LTE Band 13	10	24.0	23.02	-0.18	0	SAR-5	QPSK	1	49	16 mm	top	Tilt (Top-Back Surface)	1:1	0.177	1.253	0.222	
782.00	23230	Mid	LTE Band 13	10	23.0	22.00	-0.20	1	SAR-5	QPSK	25	12	16 mm	top	Tilt (Top-Back Surface)	1:1	0.138	1.259	0.174	
782.00	23230	Mid	LTE Band 13	10	24.0	23.02	0.03	0	SAR-5	QPSK	1	49	3 mm	right	Perpendicular	1:1	0.198	1.253	0.248	
782.00	23230	Mid	LTE Band 13	10	23.0	22.00	0.08	1	SAR-5	QPSK	25	12	3 mm	right	Perpendicular	1:1	0.190	1.259	0.239	
782.00	23230	Mid	LTE Band 13	10	24.0	23.02	0.04	0	SAR-5	QPSK	1	49	3 mm	right	Tilt (Right-Back Surface)	1:1	0.245	1.253	0.307	
782.00	23230	Mid	LTE Band 13	10	23.0	22.00	0.16	1	SAR-5	QPSK	25	12	3 mm	right	Tilt (Right-Back Surface)	1:1	0.234	1.259	0.295	
782.00	23230	Mid	LTE Band 13	10	24.0	23.02	0.12	0	SAR-5	QPSK	1	49	0 mm	left	Perpendicular	1:1	0.072	1.253	0.090	
782.00	23230	Mid	LTE Band 13	10	23.0	22.00	0.13	1	SAR-5	QPSK	25	12	0 mm	left	Perpendicular	1:1	0.060	1.259	0.076	
782.00	23230	Mid	LTE Band 13	10	24.0	23.02	-0.03	0	SAR-5	QPSK	1	49	0 mm	left	Tilt (Left-Back Surface)	1:1	0.080	1.253	0.100	
782.00	23230	Mid	LTE Band 13	10	23.0	22.00	0.12	1	SAR-5	QPSK	25	12	0 mm	left	Tilt (Left-Back Surface)	1:1	0.067	1.259	0.084	
782.00	23230	Mid	LTE Band 13	10	17.0	15.84	-0.02	0	SAR-5	QPSK	1	25	0 mm	back	Perpendicular	1:1	0.326	1.306	0.426	
782.00	23230	Mid	LTE Band 13	10	17.0	15.22	-0.04	0	SAR-5	QPSK	25	12	0 mm	back	Perpendicular	1:1	0.328	1.507	0.494	A10
782.00	23230	Mid	LTE Band 13	10	17.0	15.84	0.05	0	SAR-5	QPSK	1	25	0 mm	top	Perpendicular	1:1	0.102	1.306	0.133	
782.00	23230	Mid	LTE Band 13	10	17.0	15.22	-0.03	0	SAR-5	QPSK	25	12	0 mm	top	Perpendicular	1:1	0.105	1.507	0.158	
782.00	23230	Mid	LTE Band 13	10	17.0	15.84	0.16	0	SAR-5	QPSK	1	25	0 mm	top	Tilt (Top-Back Surface)	1:1	0.155	1.306	0.202	
782.00	23230	Mid	LTE Band 13	10	17.0	15.22	0.16	0	SAR-5	QPSK	25	12	0 mm	top	Tilt (Top-Back Surface)	1:1	0.160	1.507	0.241	
782.00	23230	Mid	LTE Band 13	10	17.0	15.84	0.15	0	SAR-5	QPSK	1	25	0 mm	right	Perpendicular	1:1	0.070	1.306	0.091	
782.00	23230	Mid	LTE Band 13	10	17.0	15.22	0.18	0	SAR-5	QPSK	25	12	0 mm	right	Perpendicular	1:1	0.070	1.507	0.105	
782.00	23230	Mid	LTE Band 13	10	17.0	15.84	-0.09	0	SAR-5	QPSK	1	25	0 mm	right	Tilt (Right-Back Surface)	1:1	0.114	1.306	0.149	
782.00	23230	Mid	LTE Band 13	10	17.0	15.22	-0.03	0	SAR-5	QPSK	25	12	0 mm	right	Tilt (Right-Back Surface)	1:1	0.115	1.507	0.173	
ANSI / IEEE C95.1 1992 - SAFETY LIMIT Spatial Peak Uncontrolled Exposure/General Population										Body 1.6 W/kg (mW/g) averaged over 1 gram										

FCC ID: ACJ9TGWW13B	 PCTEST ENGINEERING LABORATORY, INC.	SAR EVALUATION REPORT		Reviewed by: Quality Manager
Document S/N: OY1412152300.ACJ	Test Dates: 12/15/14 - 01/08/15	DUT Type: Wireless Module	Page 65 of 91	



**Table 10-6
LTE Band 5 (Cell) Body SAR Data**

MEASUREMENT RESULTS																				
FREQUENCY		Mode	Bandwidth [MHz]	Maximum Allowed Power [dBm]	Conducted Power [dBm]	Power Drift [dB]	MPR [dB]	Device Serial Number	Modulation	RB Size	RB Offset	Spacing	Side	Orientation	Duty Cycle	SAR (1g) (W/kg)	Scaling Factor	Scaled SAR (1g) (W/kg)	Plot #	
MHz	Ch.																			
836.50	20525	Mid	LTE Band 5 (Cell)	10	24.0	22.59	0.13	0	SAR-5	QPSK	1	0	18 mm	back	Perpendicular	1:1	0.253	1.384	0.350	
836.50	20525	Mid	LTE Band 5 (Cell)	10	23.0	21.61	0.09	1	SAR-5	QPSK	25	12	18 mm	back	Perpendicular	1:1	0.198	1.377	0.273	
836.50	20525	Mid	LTE Band 5 (Cell)	10	24.0	22.59	0.17	0	SAR-5	QPSK	1	0	16 mm	top	Perpendicular	1:1	0.164	1.384	0.227	
836.50	20525	Mid	LTE Band 5 (Cell)	10	23.0	21.61	-0.01	1	SAR-5	QPSK	25	12	16 mm	top	Perpendicular	1:1	0.116	1.377	0.160	
836.50	20525	Mid	LTE Band 5 (Cell)	10	24.0	22.59	-0.21	0	SAR-5	QPSK	1	0	16 mm	top	Tilt (Top-Back Surface)	1:1	0.225	1.384	0.311	
836.50	20525	Mid	LTE Band 5 (Cell)	10	23.0	21.61	0.01	1	SAR-5	QPSK	25	12	16 mm	top	Tilt (Top-Back Surface)	1:1	0.189	1.377	0.260	
836.50	20525	Mid	LTE Band 5 (Cell)	10	24.0	22.59	0.01	0	SAR-5	QPSK	1	0	3 mm	right	Perpendicular	1:1	0.193	1.384	0.267	
836.50	20525	Mid	LTE Band 5 (Cell)	10	23.0	21.61	0.05	1	SAR-5	QPSK	25	12	3 mm	right	Perpendicular	1:1	0.148	1.377	0.204	
836.50	20525	Mid	LTE Band 5 (Cell)	10	24.0	22.59	-0.03	0	SAR-5	QPSK	1	0	3 mm	right	Tilt (Right-Back Surface)	1:1	0.343	1.384	0.475	
836.50	20525	Mid	LTE Band 5 (Cell)	10	23.0	21.61	0.04	1	SAR-5	QPSK	25	12	3 mm	right	Tilt (Right-Back Surface)	1:1	0.330	1.377	0.454	
836.50	20525	Mid	LTE Band 5 (Cell)	10	24.0	22.59	-0.12	0	SAR-5	QPSK	1	0	0 mm	left	Perpendicular	1:1	0.071	1.384	0.098	
836.50	20525	Mid	LTE Band 5 (Cell)	10	23.0	21.61	0.18	1	SAR-5	QPSK	25	12	0 mm	left	Perpendicular	1:1	0.064	1.377	0.088	
836.50	20525	Mid	LTE Band 5 (Cell)	10	24.0	22.59	0.12	0	SAR-5	QPSK	1	0	0 mm	left	Tilt (Left-Back Surface)	1:1	0.129	1.384	0.179	
836.50	20525	Mid	LTE Band 5 (Cell)	10	23.0	21.61	0.02	1	SAR-5	QPSK	25	12	0 mm	left	Tilt (Left-Back Surface)	1:1	0.113	1.377	0.156	
836.50	20525	Mid	LTE Band 5 (Cell)	10	17.0	15.88	-0.13	0	SAR-5	QPSK	1	25	0 mm	back	Perpendicular	1:1	0.396	1.294	0.512	A11
836.50	20525	Mid	LTE Band 5 (Cell)	10	17.0	15.71	-0.04	0	SAR-5	QPSK	25	12	0 mm	back	Perpendicular	1:1	0.376	1.346	0.506	
836.50	20525	Mid	LTE Band 5 (Cell)	10	17.0	15.88	0.01	0	SAR-5	QPSK	1	25	0 mm	top	Perpendicular	1:1	0.174	1.294	0.225	
836.50	20525	Mid	LTE Band 5 (Cell)	10	17.0	15.71	0.13	0	SAR-5	QPSK	25	12	0 mm	top	Perpendicular	1:1	0.170	1.346	0.229	
836.50	20525	Mid	LTE Band 5 (Cell)	10	17.0	15.88	0.12	0	SAR-5	QPSK	1	25	0 mm	top	Tilt (Top-Back Surface)	1:1	0.286	1.294	0.370	
836.50	20525	Mid	LTE Band 5 (Cell)	10	17.0	15.71	0.06	0	SAR-5	QPSK	25	12	0 mm	top	Tilt (Top-Back Surface)	1:1	0.283	1.346	0.381	
836.50	20525	Mid	LTE Band 5 (Cell)	10	17.0	15.88	0.00	0	SAR-5	QPSK	1	25	0 mm	right	Perpendicular	1:1	0.069	1.294	0.089	
836.50	20525	Mid	LTE Band 5 (Cell)	10	17.0	15.71	0.05	0	SAR-5	QPSK	25	12	0 mm	right	Perpendicular	1:1	0.068	1.346	0.092	
836.50	20525	Mid	LTE Band 5 (Cell)	10	17.0	15.88	0.13	0	SAR-5	QPSK	1	25	0 mm	right	Tilt (Right-Back Surface)	1:1	0.199	1.294	0.258	
836.50	20525	Mid	LTE Band 5 (Cell)	10	17.0	15.71	0.01	0	SAR-5	QPSK	25	12	0 mm	right	Tilt (Right-Back Surface)	1:1	0.196	1.346	0.264	
ANSI / IEEE C95.1 1992 - SAFETY LIMIT Spatial Peak Uncontrolled Exposure/General Population										Body 1.6 W/kg (mW/g) averaged over 1 gram										

FCC ID: ACJ9TGWW13B	 PCTEST ENGINEERING LABORATORY, INC.	SAR EVALUATION REPORT		Reviewed by: Quality Manager
Document S/N: OY1412152300.ACJ	Test Dates: 12/15/14 - 01/08/15	DUT Type: Wireless Module		Page 66 of 91

**Table 10-7
LTE Band 4 (AWS) Body SAR Data**

MEASUREMENT RESULTS																				
FREQUENCY		Mode	Bandwidth [MHz]	Maximum Allowed Power [dBm]	Conducted Power [dBm]	Power Drift [dB]	MPR [dB]	Device Serial Number	Modulation	RB Size	RB Offset	Spacing	Side	Orientation	Duty Cycle	SAR (1g)	Scaling Factor	Scaled SAR	Plot #	
MHz	Ch.															(W/kg)		(W/kg)		
1732.50	20175	Mid	LTE Band 4 (AWS)	20	24.0	22.93	-0.05	0	SAR-5	QPSK	1	99	18 mm	back	Perpendicular	1:1	0.576	1.279	0.737	
1732.50	20175	Mid	LTE Band 4 (AWS)	20	23.0	21.64	0.08	1	SAR-5	QPSK	50	0	18 mm	back	Perpendicular	1:1	0.397	1.368	0.543	
1732.50	20175	Mid	LTE Band 4 (AWS)	20	24.0	22.93	-0.01	0	SAR-5	QPSK	1	99	16 mm	top	Perpendicular	1:1	0.502	1.279	0.642	
1732.50	20175	Mid	LTE Band 4 (AWS)	20	23.0	21.64	-0.09	1	SAR-5	QPSK	50	0	16 mm	top	Perpendicular	1:1	0.352	1.368	0.482	
1732.50	20175	Mid	LTE Band 4 (AWS)	20	24.0	22.93	0.06	0	SAR-5	QPSK	1	99	16 mm	top	Tilt (Top-Back Surface)	1:1	0.771	1.279	0.986	A12
1732.50	20175	Mid	LTE Band 4 (AWS)	20	23.0	21.64	0.00	1	SAR-5	QPSK	50	0	16 mm	top	Tilt (Top-Back Surface)	1:1	0.539	1.368	0.737	
1732.50	20175	Mid	LTE Band 4 (AWS)	20	23.0	21.63	0.00	1	SAR-5	QPSK	100	0	16 mm	top	Tilt (Top-Back Surface)	1:1	0.550	1.371	0.754	
1732.50	20175	Mid	LTE Band 4 (AWS)	20	24.0	22.93	-0.05	0	SAR-5	QPSK	1	99	16 mm	right	Perpendicular	1:1	0.262	1.279	0.335	
1732.50	20175	Mid	LTE Band 4 (AWS)	20	23.0	21.64	0.04	1	SAR-5	QPSK	50	0	3 mm	right	Perpendicular	1:1	0.209	1.368	0.286	
1732.50	20175	Mid	LTE Band 4 (AWS)	20	24.0	22.93	0.04	0	SAR-5	QPSK	1	99	3 mm	right	Tilt (Right-Back Surface)	1:1	0.652	1.279	0.834	
1732.50	20175	Mid	LTE Band 4 (AWS)	20	23.0	21.64	-0.01	1	SAR-5	QPSK	50	0	3 mm	right	Tilt (Right-Back Surface)	1:1	0.499	1.368	0.683	
1732.50	20175	Mid	LTE Band 4 (AWS)	20	23.0	21.63	0.11	1	SAR-5	QPSK	100	0	3 mm	right	Tilt (Right-Back Surface)	1:1	0.551	1.371	0.755	
1732.50	20175	Mid	LTE Band 4 (AWS)	20	24.0	22.93	-0.12	0	SAR-5	QPSK	1	99	0 mm	left	Perpendicular	1:1	0.008	1.279	0.010	
1732.50	20175	Mid	LTE Band 4 (AWS)	20	23.0	21.64	0.14	0	SAR-5	QPSK	50	0	0 mm	left	Perpendicular	1:1	0.009	1.368	0.012	
1732.50	20175	Mid	LTE Band 4 (AWS)	20	24.0	22.93	0.12	0	SAR-5	QPSK	1	99	0 mm	left	Tilt (Left-Back Surface)	1:1	0.034	1.279	0.043	
1732.50	20175	Mid	LTE Band 4 (AWS)	20	23.0	21.64	0.04	1	SAR-5	QPSK	50	0	0 mm	left	Tilt (Left-Back Surface)	1:1	0.022	1.368	0.030	
1732.50	20175	Mid	LTE Band 4 (AWS)	20	11.0	10.65	-0.03	0	SAR-5	QPSK	1	50	0 mm	back	Perpendicular	1:1	0.566	1.084	0.614	
1732.50	20175	Mid	LTE Band 4 (AWS)	20	11.0	10.60	-0.03	0	SAR-5	QPSK	50	25	0 mm	back	Perpendicular	1:1	0.563	1.096	0.617	
1732.50	20175	Mid	LTE Band 4 (AWS)	20	11.0	10.65	-0.01	0	SAR-5	QPSK	1	50	0 mm	top	Perpendicular	1:1	0.167	1.084	0.181	
1732.50	20175	Mid	LTE Band 4 (AWS)	20	11.0	10.60	-0.01	0	SAR-5	QPSK	50	25	0 mm	top	Perpendicular	1:1	0.164	1.096	0.180	
1732.50	20175	Mid	LTE Band 4 (AWS)	20	11.0	10.65	-0.01	0	SAR-5	QPSK	1	50	0 mm	top	Tilt (Top-Back Surface)	1:1	0.288	1.084	0.312	
1732.50	20175	Mid	LTE Band 4 (AWS)	20	11.0	10.60	-0.05	0	SAR-5	QPSK	50	25	0 mm	top	Tilt (Top-Back Surface)	1:1	0.285	1.096	0.312	
1732.50	20175	Mid	LTE Band 4 (AWS)	20	11.0	10.65	-0.03	0	SAR-5	QPSK	1	50	0 mm	right	Perpendicular	1:1	0.031	1.084	0.034	
1732.50	20175	Mid	LTE Band 4 (AWS)	20	11.0	10.60	0.03	0	SAR-5	QPSK	50	25	0 mm	right	Perpendicular	1:1	0.031	1.096	0.034	
1732.50	20175	Mid	LTE Band 4 (AWS)	20	11.0	10.65	0.13	0	SAR-5	QPSK	1	50	0 mm	right	Tilt (Right-Back Surface)	1:1	0.075	1.084	0.081	
1732.50	20175	Mid	LTE Band 4 (AWS)	20	11.0	10.60	0.07	0	SAR-5	QPSK	50	25	0 mm	right	Tilt (Right-Back Surface)	1:1	0.076	1.096	0.083	
ANSI / IEEE C95.1 1992 - SAFETY LIMIT Spatial Peak Uncontrolled Exposure/General Population										Body 1.6 W/kg (mW/g) averaged over 1 gram										

FCC ID: ACJ9TGWW13B	 PCTEST ENGINEERING LABORATORY, INC.	SAR EVALUATION REPORT		Reviewed by: Quality Manager
Document S/N: OY1412152300.ACJ	Test Dates: 12/15/14 - 01/08/15	DUT Type: Wireless Module		Page 67 of 91



**Table 10-8
LTE Band 25 (PCS) Body SAR Data**

MEASUREMENT RESULTS																				
FREQUENCY		Mode	Bandwidth [MHz]	Maximum Allowed Power [dBm]	Conducted Power [dBm]	Power Drift [dB]	MPR [dB]	Device Serial Number	Modulation	RB Size	RB Offset	Spacing	Side	Orientation	Duty Cycle	SAR (1g)	Scaling Factor	Scaled SAR (1g) (W/kg)	Plot #	
MHz	Ch.															(W/kg)		(W/kg)		
1860.00	26140	Low	LTE Band 25 (PCS)	20	24.0	22.94	-0.04	0	SAR-4	QPSK	1	99	18 mm	back	Perpendicular	1:1	0.641	1.276	0.818	
1882.50	26365	Mid	LTE Band 25 (PCS)	20	24.0	22.78	-0.13	0	SAR-4	QPSK	1	0	18 mm	back	Perpendicular	1:1	0.728	1.324	0.964	
1905.00	26590	High	LTE Band 25 (PCS)	20	24.0	23.06	-0.12	0	SAR-4	QPSK	1	50	18 mm	back	Perpendicular	1:1	0.811	1.242	1.007	A13
1905.00	26590	High	LTE Band 25 (PCS)	20	23.0	22.06	-0.12	1	SAR-4	QPSK	50	50	18 mm	back	Perpendicular	1:1	0.595	1.242	0.739	
1905.00	26590	High	LTE Band 25 (PCS)	20	23.0	21.77	0.12	1	SAR-4	QPSK	100	0	18 mm	back	Perpendicular	1:1	0.602	1.327	0.799	
1905.00	26590	High	LTE Band 25 (PCS)	20	24.0	23.06	0.03	0	SAR-4	QPSK	1	50	16 mm	top	Perpendicular	1:1	0.541	1.242	0.672	
1905.00	26590	High	LTE Band 25 (PCS)	20	23.0	22.06	0.02	1	SAR-4	QPSK	50	50	16 mm	top	Perpendicular	1:1	0.435	1.242	0.540	
1860.00	26140	Low	LTE Band 25 (PCS)	20	24.0	22.94	-0.03	0	SAR-4	QPSK	1	99	16 mm	top	Tilt (Top-Back Surface)	1:1	0.704	1.276	0.898	
1882.50	26365	Mid	LTE Band 25 (PCS)	20	24.0	22.78	0.09	0	SAR-4	QPSK	1	0	16 mm	top	Tilt (Top-Back Surface)	1:1	0.756	1.324	1.001	
1905.00	26590	High	LTE Band 25 (PCS)	20	24.0	23.06	0.00	0	SAR-4	QPSK	1	50	16 mm	top	Tilt (Top-Back Surface)	1:1	0.779	1.242	0.968	
1905.00	26590	High	LTE Band 25 (PCS)	20	23.0	22.06	-0.02	1	SAR-4	QPSK	50	50	16 mm	top	Tilt (Top-Back Surface)	1:1	0.638	1.242	0.792	
1905.00	26590	High	LTE Band 25 (PCS)	20	23.0	21.77	0.08	1	SAR-4	QPSK	100	0	16 mm	top	Tilt (Top-Back Surface)	1:1	0.622	1.327	0.825	
1905.00	26590	High	LTE Band 25 (PCS)	20	24.0	23.06	0.14	0	SAR-4	QPSK	1	50	3 mm	right	Perpendicular	1:1	0.080	1.242	0.099	
1905.00	26590	High	LTE Band 25 (PCS)	20	23.0	22.06	0.06	1	SAR-4	QPSK	50	50	3 mm	right	Perpendicular	1:1	0.059	1.242	0.073	
1905.00	26590	High	LTE Band 25 (PCS)	20	24.0	23.06	0.01	0	SAR-4	QPSK	1	50	3 mm	right	Tilt (Right-Back Surface)	1:1	0.294	1.242	0.365	
1905.00	26590	High	LTE Band 25 (PCS)	20	23.0	22.06	-0.01	1	SAR-4	QPSK	50	50	3 mm	right	Tilt (Right-Back Surface)	1:1	0.223	1.242	0.277	
1905.00	26590	High	LTE Band 25 (PCS)	20	24.0	23.06	0.15	0	SAR-4	QPSK	1	50	0 mm	left	Perpendicular	1:1	0.026	1.242	0.032	
1905.00	26590	High	LTE Band 25 (PCS)	20	23.0	22.06	0.12	1	SAR-4	QPSK	50	50	0 mm	left	Perpendicular	1:1	0.028	1.242	0.035	
1905.00	26590	High	LTE Band 25 (PCS)	20	24.0	23.06	0.12	0	SAR-4	QPSK	1	50	0 mm	left	Tilt (Left-Back Surface)	1:1	0.020	1.242	0.025	
1905.00	26590	High	LTE Band 25 (PCS)	20	23.0	22.06	0.15	1	SAR-4	QPSK	50	50	0 mm	left	Tilt (Left-Back Surface)	1:1	0.018	1.242	0.022	
1860.00	26140	Low	LTE Band 25 (PCS)	20	12.0	11.60	-0.08	0	SAR-4	QPSK	1	50	0 mm	back	Perpendicular	1:1	0.516	1.096	0.566	
1905.00	26590	High	LTE Band 25 (PCS)	20	12.0	11.58	-0.12	0	SAR-4	QPSK	50	50	0 mm	back	Perpendicular	1:1	0.504	1.102	0.555	
1860.00	26140	Low	LTE Band 25 (PCS)	20	12.0	11.60	0.02	0	SAR-4	QPSK	1	50	0 mm	top	Perpendicular	1:1	0.203	1.096	0.222	
1905.00	26590	High	LTE Band 25 (PCS)	20	12.0	11.58	-0.04	0	SAR-4	QPSK	50	50	0 mm	top	Perpendicular	1:1	0.186	1.102	0.205	
1860.00	26140	Low	LTE Band 25 (PCS)	20	12.0	11.60	0.11	0	SAR-4	QPSK	1	50	0 mm	top	Tilt (Top-Back Surface)	1:1	0.264	1.096	0.289	
1905.00	26590	High	LTE Band 25 (PCS)	20	12.0	11.58	0.04	0	SAR-4	QPSK	50	50	0 mm	top	Tilt (Top-Back Surface)	1:1	0.284	1.102	0.313	
1860.00	26140	Low	LTE Band 25 (PCS)	20	12.0	11.60	0.14	0	SAR-4	QPSK	1	50	0 mm	right	Perpendicular	1:1	0.012	1.096	0.013	
1905.00	26590	High	LTE Band 25 (PCS)	20	12.0	11.58	0.13	0	SAR-4	QPSK	50	50	0 mm	right	Perpendicular	1:1	0.006	1.102	0.007	
1860.00	26140	Low	LTE Band 25 (PCS)	20	12.0	11.60	0.08	0	SAR-4	QPSK	1	50	0 mm	right	Tilt (Right-Back Surface)	1:1	0.038	1.096	0.042	
1905.00	26590	High	LTE Band 25 (PCS)	20	12.0	11.58	0.14	0	SAR-4	QPSK	50	50	0 mm	right	Tilt (Right-Back Surface)	1:1	0.024	1.102	0.026	
ANSI / IEEE C95.1 1992 - SAFETY LIMIT										Body										
Spatial Peak										1.6 W/kg (mW/g)										
Uncontrolled Exposure/General Population										averaged over 1 gram										

10.2 SAR Test Notes

General Notes:

- The test data reported are the worst-case SAR values according to test procedures specified in FCC KDB 616217 and FCC KDB Publication 447498 D01v05.
- Batteries are fully charged at the beginning of the SAR measurements.
- Liquid tissue depth was at least 15.0 cm for all frequencies.
- The manufacturer has confirmed that the device(s) tested have the same physical, mechanical and thermal characteristics and are within operational tolerances expected for production units.
- SAR results were scaled to the maximum allowed power to demonstrate compliance per FCC KDB Publication 447498 D01v05.
- Per FCC KDB 865664 D01 v01, variability SAR tests were performed when the measured SAR results for a frequency band were greater than 0.8 W/kg. Repeated SAR measurements are highlighted in the tables above for clarity. Please see Section 12 for variability analysis.
- Per FCC KDB 616217 D04 Section 4.3, SAR tests are required for the back surface and edges of the tablet with the tablet touching the phantom. The SAR Exclusion Threshold in FCC KDB 447498 D01v05 was applied to determine SAR test exclusion for adjacent edge configurations. Top, Right, and left edge SAR tests were required for the main antenna.

FCC ID: ACJ9TGWW13B		SAR EVALUATION REPORT		Reviewed by: Quality Manager
Document S/N: OY1412152300.ACJ	Test Dates: 12/15/14 - 01/08/15	DUT Type: Wireless Module		Page 68 of 91

- Due to the unique form factor of the device, we have tested each required edge with two different orientations per FCC Guidance. Appendix E contains test setup photographs showing Top Tilt (Top-Back Surface), Right Tilt (Right-Back Surface), and Left Tilt (Left-Back Surface) Positions.

GSM Test Notes:

- Justification for reduced test configurations per KDB Publication 941225 D03v01 and October 2013 TCB Workshop Notes: The source-based frame-averaged output power was evaluated for all GPRS/EDGE slot configurations. The configuration with the highest target frame averaged output power was evaluated for SAR. When the maximum frame-averaged powers are equivalent across two or more slots (within 0.25 dB), the configuration with the most number of time slots was tested.
- Per FCC KDB Publication 447498 D01v05, if the reported (scaled) SAR measured at the middle channel or highest output power channel for each test configuration is ≤ 0.8 W/kg then testing at the other channels is not required for such test configuration(s). When the maximum output power variation across the required test channels is $> \frac{1}{2}$ dB, instead of the middle channel, the highest output power channel was used.

CDMA Notes:



- CDMA SAR is measured using Subtype 0/1 Physical Layer configurations for Rev. 0 according to KDB 941225 D01 procedures for data devices. PerKDB 941225 D01v03 3G test reduction procedure, 1xRTT SAR and EVDO Rev. A SAR are not required.
- Per FCC KDB Publication 447498 D01v05, if the reported (scaled) SAR measured at the middle channel or highest output power channel for each test configuration is ≤ 0.8 W/kg then testing at the other channels is not required for such test configuration(s). When the maximum output power variation across the required test channels is $> \frac{1}{2}$ dB, instead of the middle channel, the highest output power channel was used.

UMTS Notes:

- UMTS mode in was tested under RMC 12.2 kbps with HSPA Inactive per KDB Publication 941225 D01v03. HSPA SAR was not required per KDB Publication 941225 D01v03 3G test reduction policy.
- Per FCC KDB Publication 447498 D01v05, if the reported (scaled) SAR measured at the middle channel or highest output power channel for each test configuration is ≤ 0.8 W/kg then testing at the other channels is not required for such test configuration(s). When the maximum output power variation across the required test channels is $> \frac{1}{2}$ dB, instead of the middle channel, the highest output power channel was used.

LTE Notes:

- LTE Considerations: LTE test configurations are determined according to SAR Evaluation Considerations for LTE Devices in FCC KDB Publication 941225 D05v02r01. The general test procedures used for testing can be found in Section 7.5.4.
- MPR is permanently implemented for this device by the manufacturer. The specific manufacturer target MPR is indicated alongside the SAR results. MPR is enabled for this device, according to 3GPP TS36.101 Section 6.2.3 – 6.2.5 under Table 6.2.3-1.
- A-MPR was disabled for all SAR tests by setting NS=01 on the base station simulator. SAR tests were performed with the same number of RB and RB offsets transmitting on all TTI frames (maximum TTI).

FCC ID: ACJ9TGWW13B		SAR EVALUATION REPORT		Reviewed by: Quality Manager
Document S/N: OY1412152300.ACJ	Test Dates: 12/15/14 - 01/08/15	DUT Type: Wireless Module		Page 69 of 91

11 FCC MULTI-TX AND ANTENNA SAR CONSIDERATIONS

11.1 Introduction

The following procedures adopted from FCC KDB Publication 447498 D01v05 are applicable to handsets with built-in unlicensed transmitters such as 802.11a/b/g/n/ac and Bluetooth devices which may simultaneously transmit with the licensed transmitter.

The FZ-R1 additionally contains BT/WIFI transmitter ACJ9TGWL13A. Please reference the corresponding SAR report (0Y1412152288-R1.ACJ) for WIFI test data.

11.2 Simultaneous Transmission Procedures

This device contains transmitters that may operate simultaneously. Therefore simultaneous transmission analysis is required. Per FCC KDB 447498 D01v05 IV.C.1.iii and IEEE 1528-2013 Section 6.3.4.1.2, simultaneous transmission SAR test exclusion may be applied when the sum of the 1-g SAR for all the simultaneous transmitting antennas in a specific a physical test configuration is ≤ 1.6 W/kg. When standalone SAR is not required to be measured, per FCC KDB 447498 D01v05 4.3.2 2), the following equation must be used to estimate the standalone 1g SAR for simultaneous transmission assessment involving that transmitter.

$$\text{Estimated SAR} = \frac{\sqrt{f(\text{GHz})}}{7.5} * \frac{(\text{Max Power of channel, mW})}{\text{Min. Separation Distance, mm}}$$

**Table 11-1
Estimated SAR**

Mode	Frequency	Maximum Allowed Power	Separation Distance (Body)	Estimated SAR (Body)
	[MHz]	[dBm]	[mm]	[W/kg]
2.4 GHz WLAN Top Edge Antenna 2	2457	14.00	44.75	0.117
5 GHz WLAN Top Edge Antenna 2	5825	15.00	44.75	0.230
Bluetooth Top Edge	2480	8.50	44.75	0.033

Note: The worst case reported SAR for position was used for SAR summation, regardless of orientation (perpendicular or tilt). Therefore, the summations below represent the absolute worst cases for simultaneous transmission.



FCC ID: ACJ9TGWW13B	 PCTEST ENGINEERING LABORATORY, INC.	SAR EVALUATION REPORT		Reviewed by: Quality Manager
Document S/N: 0Y1412152300.ACJ	Test Dates: 12/15/14 - 01/08/15	DUT Type: Wireless Module	Page 70 of 91	

Table 11-3
Simultaneous Transmission Scenario with 2.4 GHz WLAN Antenna 2 (Body at 0 mm)

Simult Tx	Configuration	GPRS 850 SAR (W/kg)	2.4 GHz WLAN Ant 2 SAR (W/kg)	Σ SAR (W/kg)	Simult Tx	Configuration	GPRS 1900 SAR (W/kg)	2.4 GHz WLAN Ant 2 SAR (W/kg)	Σ SAR (W/kg)
Body SAR	Back	0.455	0.025	0.480	Body SAR	Back	0.470	0.025	0.495
	Top	0.319	0.117	0.436		Top	0.250	0.117	0.367
	Bottom	0.400	0.400	0.800		Bottom	0.400	0.400	0.800
	Right	0.152	0.144	0.296		Right	0.077	0.144	0.221
	Left	0.326	0.400	0.726		Left	0.035	0.400	0.435
Simult Tx	Configuration	UMTS 850 SAR (W/kg)	2.4 GHz WLAN Ant 2 SAR (W/kg)	Σ SAR (W/kg)	Simult Tx	Configuration	UMTS 1750 SAR (W/kg)	2.4 GHz WLAN Ant 2 SAR (W/kg)	Σ SAR (W/kg)
Body SAR	Back	0.486	0.025	0.511	Body SAR	Back	0.497	0.025	0.522
	Top	0.346	0.117	0.463		Top	0.302	0.117	0.419
	Bottom	0.400	0.400	0.800		Bottom	0.400	0.400	0.800
	Right	0.177	0.144	0.321		Right	0.075	0.144	0.219
	Left	0.171	0.400	0.571		Left	0.126	0.400	0.526
Simult Tx	Configuration	UMTS 1900 SAR (W/kg)	2.4 GHz WLAN Ant 2 SAR (W/kg)	Σ SAR (W/kg)	Simult Tx	Configuration	EVDO BC10 (\$90S) SAR (W/kg)	2.4 GHz WLAN Ant 2 SAR (W/kg)	Σ SAR (W/kg)
Body SAR	Back	0.606	0.025	0.631	Body SAR	Back	0.632	0.025	0.657
	Top	0.380	0.117	0.497		Top	0.343	0.117	0.460
	Bottom	0.400	0.400	0.800		Bottom	0.400	0.400	0.800
	Right	0.033	0.144	0.177		Right	0.207	0.144	0.351
	Left	0.043	0.400	0.443		Left	0.201	0.400	0.601
Simult Tx	Configuration	EVDO BC0 (\$22H) SAR (W/kg)	2.4 GHz WLAN Ant 2 SAR (W/kg)	Σ SAR (W/kg)	Simult Tx	Configuration	PCS EVDO SAR (W/kg)	2.4 GHz WLAN Ant 2 SAR (W/kg)	Σ SAR (W/kg)
Body SAR	Back	0.700	0.025	0.725	Body SAR	Back	0.555	0.025	0.580
	Top	0.424	0.117	0.541		Top	0.299	0.117	0.416
	Bottom	0.400	0.400	0.800		Bottom	0.400	0.400	0.800
	Right	0.188	0.144	0.332		Right	0.032	0.144	0.176
	Left	0.195	0.400	0.595		Left	0.052	0.400	0.452
Simult Tx	Configuration	LTE Band 17 SAR (W/kg)	2.4 GHz WLAN Ant 2 SAR (W/kg)	Σ SAR (W/kg)	Simult Tx	Configuration	LTE Band 13 SAR (W/kg)	2.4 GHz WLAN Ant 2 SAR (W/kg)	Σ SAR (W/kg)
Body SAR	Back	0.403	0.025	0.428	Body SAR	Back	0.494	0.025	0.519
	Top	0.177	0.117	0.294		Top	0.241	0.117	0.358
	Bottom	0.400	0.400	0.800		Bottom	0.400	0.400	0.800
	Right	0.115	0.144	0.259		Right	0.173	0.144	0.317
	Left	0.127	0.400	0.527		Left	0.100	0.400	0.500
Simult Tx	Configuration	LTE Band 5 (Cell) SAR (W/kg)	2.4 GHz WLAN Ant 2 SAR (W/kg)	Σ SAR (W/kg)	Simult Tx	Configuration	LTE Band 4 (AWS) SAR (W/kg)	2.4 GHz WLAN Ant 2 SAR (W/kg)	Σ SAR (W/kg)
Body SAR	Back	0.512	0.025	0.537	Body SAR	Back	0.617	0.025	0.642
	Top	0.381	0.117	0.498		Top	0.312	0.117	0.429
	Bottom	0.400	0.400	0.800		Bottom	0.400	0.400	0.800
	Right	0.264	0.144	0.408		Right	0.083	0.144	0.227
	Left	0.179	0.400	0.579		Left	0.043	0.400	0.443

Simult Tx	Configuration	LTE Band 25 (PCS) SAR (W/kg)	2.4 GHz WLAN Ant 2 SAR (W/kg)	Σ SAR (W/kg)
Body SAR	Back	0.566	0.025	0.591
	Top	0.313	0.117	0.430
	Bottom	0.400	0.400	0.800
	Right	0.042	0.144	0.186
	Left	0.035	0.400	0.435



FCC ID: ACJ9TGWW13B		SAR EVALUATION REPORT		Reviewed by: Quality Manager
Document S/N: OY1412152300.ACJ	Test Dates: 12/15/14 - 01/08/15	DUT Type: Wireless Module	Page 72 of 91	

Table 11-4
Simultaneous Transmission Scenario with 2.4 GHz WLAN MIMO (Body at 0 mm)

Simult Tx	Configuration	GPRS 850 SAR (W/kg)	2.4 GHz WLAN MIMO SAR (W/kg)	Σ SAR (W/kg)	Simult Tx	Configuration	GPRS 1900 SAR (W/kg)	2.4 GHz WLAN MIMO SAR (W/kg)	Σ SAR (W/kg)
Body SAR	Back	0.455	0.155	0.610	Body SAR	Back	0.470	0.155	0.625
	Top	0.319	0.083	0.402		Top	0.250	0.083	0.333
	Bottom	0.400	0.400	0.800		Bottom	0.400	0.400	0.800
	Right	0.152	0.068	0.220		Right	0.077	0.068	0.145
	Left	0.326	0.165	0.491		Left	0.035	0.165	0.200
Simult Tx	Configuration	UMTS 850 SAR (W/kg)	2.4 GHz WLAN MIMO SAR (W/kg)	Σ SAR (W/kg)	Simult Tx	Configuration	UMTS 1750 SAR (W/kg)	2.4 GHz WLAN MIMO SAR (W/kg)	Σ SAR (W/kg)
Body SAR	Back	0.486	0.155	0.641	Body SAR	Back	0.497	0.155	0.652
	Top	0.346	0.083	0.429		Top	0.302	0.083	0.385
	Bottom	0.400	0.400	0.800		Bottom	0.400	0.400	0.800
	Right	0.177	0.068	0.245		Right	0.075	0.068	0.143
	Left	0.171	0.165	0.336		Left	0.126	0.165	0.291
Simult Tx	Configuration	UMTS 1900 SAR (W/kg)	2.4 GHz WLAN MIMO SAR (W/kg)	Σ SAR (W/kg)	Simult Tx	Configuration	EVDO BC10 (\$90S) SAR (W/kg)	2.4 GHz WLAN MIMO SAR (W/kg)	Σ SAR (W/kg)
Body SAR	Back	0.606	0.155	0.761	Body SAR	Back	0.632	0.155	0.787
	Top	0.380	0.083	0.463		Top	0.343	0.083	0.426
	Bottom	0.400	0.400	0.800		Bottom	0.400	0.400	0.800
	Right	0.033	0.068	0.101		Right	0.207	0.068	0.275
	Left	0.043	0.165	0.208		Left	0.201	0.165	0.366
Simult Tx	Configuration	EVDO BC0 (\$22H) SAR (W/kg)	2.4 GHz WLAN MIMO SAR (W/kg)	Σ SAR (W/kg)	Simult Tx	Configuration	PCS EVDO SAR (W/kg)	2.4 GHz WLAN MIMO SAR (W/kg)	Σ SAR (W/kg)
Body SAR	Back	0.700	0.155	0.855	Body SAR	Back	0.555	0.155	0.710
	Top	0.424	0.083	0.507		Top	0.299	0.083	0.382
	Bottom	0.400	0.400	0.800		Bottom	0.400	0.400	0.800
	Right	0.188	0.068	0.256		Right	0.032	0.068	0.100
	Left	0.195	0.165	0.360		Left	0.052	0.165	0.217
Simult Tx	Configuration	LTE Band 17 SAR (W/kg)	2.4 GHz WLAN MIMO SAR (W/kg)	Σ SAR (W/kg)	Simult Tx	Configuration	LTE Band 13 SAR (W/kg)	2.4 GHz WLAN MIMO SAR (W/kg)	Σ SAR (W/kg)
Body SAR	Back	0.403	0.155	0.558	Body SAR	Back	0.494	0.155	0.649
	Top	0.177	0.083	0.260		Top	0.241	0.083	0.324
	Bottom	0.400	0.400	0.800		Bottom	0.400	0.400	0.800
	Right	0.115	0.068	0.183		Right	0.173	0.068	0.241
	Left	0.127	0.165	0.292		Left	0.100	0.165	0.265
Simult Tx	Configuration	LTE Band 5 (Cell) SAR (W/kg)	2.4 GHz WLAN MIMO SAR (W/kg)	Σ SAR (W/kg)	Simult Tx	Configuration	LTE Band 4 (AWS) SAR (W/kg)	2.4 GHz WLAN MIMO SAR (W/kg)	Σ SAR (W/kg)
Body SAR	Back	0.512	0.155	0.667	Body SAR	Back	0.617	0.155	0.772
	Top	0.381	0.083	0.464		Top	0.312	0.083	0.395
	Bottom	0.400	0.400	0.800		Bottom	0.400	0.400	0.800
	Right	0.264	0.068	0.332		Right	0.083	0.068	0.151
	Left	0.179	0.165	0.344		Left	0.043	0.165	0.208

Simult Tx	Configuration	LTE Band 25 (PCS) SAR (W/kg)	2.4 GHz WLAN MIMO SAR (W/kg)	Σ SAR (W/kg)
Body SAR	Back	0.566	0.155	0.721
	Top	0.313	0.083	0.396
	Bottom	0.400	0.400	0.800
	Right	0.042	0.068	0.110
	Left	0.035	0.165	0.200



FCC ID: ACJ9TGWW13B	 PCTEST ENGINEERING LABORATORY, INC.	SAR EVALUATION REPORT		Reviewed by: Quality Manager
Document S/N: OY1412152300.ACJ	Test Dates: 12/15/14 - 01/08/15	DUT Type: Wireless Module	Page 73 of 91	

Table 11-5
Simultaneous Transmission Scenario with 5 GHz WLAN Antenna 1 (Body at 0 mm)

Simult Tx	Configuration	GPRS 850 SAR (W/kg)	5 GHz WLAN Ant 1 SAR (W/kg)	Σ SAR (W/kg)	Simult Tx	Configuration	GPRS 1900 SAR (W/kg)	5 GHz WLAN Ant 1 SAR (W/kg)	Σ SAR (W/kg)
Body SAR	Back	0.455	0.568	1.023	Body SAR	Back	0.470	0.568	1.038
	Top	0.319	0.347	0.666		Top	0.250	0.347	0.597
	Bottom	0.400	0.400	0.800		Bottom	0.400	0.400	0.800
	Right	0.152	0.400	0.552		Right	0.077	0.400	0.477
	Left	0.326	0.488	0.814		Left	0.035	0.488	0.523
Simult Tx	Configuration	UMTS 850 SAR (W/kg)	5 GHz WLAN Ant 1 SAR (W/kg)	Σ SAR (W/kg)	Simult Tx	Configuration	UMTS 1750 SAR (W/kg)	5 GHz WLAN Ant 1 SAR (W/kg)	Σ SAR (W/kg)
Body SAR	Back	0.486	0.568	1.054	Body SAR	Back	0.497	0.568	1.065
	Top	0.346	0.347	0.693		Top	0.302	0.347	0.649
	Bottom	0.400	0.400	0.800		Bottom	0.400	0.400	0.800
	Right	0.177	0.400	0.577		Right	0.075	0.400	0.475
	Left	0.171	0.488	0.659		Left	0.126	0.488	0.614
Simult Tx	Configuration	UMTS 1900 SAR (W/kg)	5 GHz WLAN Ant 1 SAR (W/kg)	Σ SAR (W/kg)	Simult Tx	Configuration	EVDO BC10 (\$90S) SAR (W/kg)	5 GHz WLAN Ant 1 SAR (W/kg)	Σ SAR (W/kg)
Body SAR	Back	0.606	0.568	1.174	Body SAR	Back	0.632	0.568	1.200
	Top	0.380	0.347	0.727		Top	0.343	0.347	0.690
	Bottom	0.400	0.400	0.800		Bottom	0.400	0.400	0.800
	Right	0.033	0.400	0.433		Right	0.207	0.400	0.607
	Left	0.043	0.488	0.531		Left	0.201	0.488	0.689
Simult Tx	Configuration	EVDO BC0 (\$22H) SAR (W/kg)	5 GHz WLAN Ant 1 SAR (W/kg)	Σ SAR (W/kg)	Simult Tx	Configuration	PCS EVDO SAR (W/kg)	5 GHz WLAN Ant 1 SAR (W/kg)	Σ SAR (W/kg)
Body SAR	Back	0.700	0.568	1.268	Body SAR	Back	0.555	0.568	1.123
	Top	0.424	0.347	0.771		Top	0.299	0.347	0.646
	Bottom	0.400	0.400	0.800		Bottom	0.400	0.400	0.800
	Right	0.188	0.400	0.588		Right	0.032	0.400	0.432
	Left	0.195	0.488	0.683		Left	0.052	0.488	0.540
Simult Tx	Configuration	LTE Band 17 SAR (W/kg)	5 GHz WLAN Ant 1 SAR (W/kg)	Σ SAR (W/kg)	Simult Tx	Configuration	LTE Band 13 SAR (W/kg)	5 GHz WLAN Ant 1 SAR (W/kg)	Σ SAR (W/kg)
Body SAR	Back	0.403	0.568	0.971	Body SAR	Back	0.494	0.568	1.062
	Top	0.177	0.347	0.524		Top	0.241	0.347	0.588
	Bottom	0.400	0.400	0.800		Bottom	0.400	0.400	0.800
	Right	0.115	0.400	0.515		Right	0.173	0.400	0.573
	Left	0.127	0.488	0.615		Left	0.100	0.488	0.588
Simult Tx	Configuration	LTE Band 5 (Cell) SAR (W/kg)	5 GHz WLAN Ant 1 SAR (W/kg)	Σ SAR (W/kg)	Simult Tx	Configuration	LTE Band 4 (AWS) SAR (W/kg)	5 GHz WLAN Ant 1 SAR (W/kg)	Σ SAR (W/kg)
Body SAR	Back	0.512	0.568	1.080	Body SAR	Back	0.617	0.568	1.185
	Top	0.381	0.347	0.728		Top	0.312	0.347	0.659
	Bottom	0.400	0.400	0.800		Bottom	0.400	0.400	0.800
	Right	0.264	0.400	0.664		Right	0.083	0.400	0.483
	Left	0.179	0.488	0.667		Left	0.043	0.488	0.531

Simult Tx	Configuration	LTE Band 25 (PCS) SAR (W/kg)	5 GHz WLAN Ant 1 SAR (W/kg)	Σ SAR (W/kg)
Body SAR	Back	0.566	0.568	1.134
	Top	0.313	0.347	0.660
	Bottom	0.400	0.400	0.800
	Right	0.042	0.400	0.442
	Left	0.035	0.488	0.523



FCC ID: ACJ9TGWW13B	 PCTEST ENGINEERING LABORATORY, INC.	SAR EVALUATION REPORT		Reviewed by: Quality Manager
Document S/N: OY1412152300.ACJ	Test Dates: 12/15/14 - 01/08/15	DUT Type: Wireless Module		Page 74 of 91

Table 11-6
Simultaneous Transmission Scenario with 5 GHz WLAN Antenna 2 (Body at 0 mm)

Simult Tx	Configuration	GPRS 850 SAR (W/kg)	5 GHz WLAN Ant 2 SAR (W/kg)	Σ SAR (W/kg)	Simult Tx	Configuration	GPRS 1900 SAR (W/kg)	5 GHz WLAN Ant 2 SAR (W/kg)	Σ SAR (W/kg)
Body SAR	Back	0.455	0.037	0.492	Body SAR	Back	0.470	0.037	0.507
	Top	0.319	0.230	0.549		Top	0.250	0.230	0.480
	Bottom	0.400	0.400	0.800		Bottom	0.400	0.400	0.800
	Right	0.152	0.379	0.531		Right	0.077	0.379	0.456
	Left	0.326	0.400	0.726		Left	0.035	0.400	0.435
Simult Tx	Configuration	UMTS 850 SAR (W/kg)	5 GHz WLAN Ant 2 SAR (W/kg)	Σ SAR (W/kg)	Simult Tx	Configuration	UMTS 1750 SAR (W/kg)	5 GHz WLAN Ant 2 SAR (W/kg)	Σ SAR (W/kg)
Body SAR	Back	0.486	0.037	0.523	Body SAR	Back	0.497	0.037	0.534
	Top	0.346	0.230	0.576		Top	0.302	0.230	0.532
	Bottom	0.400	0.400	0.800		Bottom	0.400	0.400	0.800
	Right	0.177	0.379	0.556		Right	0.075	0.379	0.454
	Left	0.171	0.400	0.571		Left	0.126	0.400	0.526
Simult Tx	Configuration	UMTS 1900 SAR (W/kg)	5 GHz WLAN Ant 2 SAR (W/kg)	Σ SAR (W/kg)	Simult Tx	Configuration	EVDO BC10 (\$90S) SAR (W/kg)	5 GHz WLAN Ant 2 SAR (W/kg)	Σ SAR (W/kg)
Body SAR	Back	0.606	0.037	0.643	Body SAR	Back	0.632	0.037	0.669
	Top	0.380	0.230	0.610		Top	0.343	0.230	0.573
	Bottom	0.400	0.400	0.800		Bottom	0.400	0.400	0.800
	Right	0.033	0.379	0.412		Right	0.207	0.379	0.586
	Left	0.043	0.400	0.443		Left	0.201	0.400	0.601
Simult Tx	Configuration	EVDO BC0 (\$22H) SAR (W/kg)	5 GHz WLAN Ant 2 SAR (W/kg)	Σ SAR (W/kg)	Simult Tx	Configuration	PCS EVDO SAR (W/kg)	5 GHz WLAN Ant 2 SAR (W/kg)	Σ SAR (W/kg)
Body SAR	Back	0.700	0.037	0.737	Body SAR	Back	0.555	0.037	0.592
	Top	0.424	0.230	0.654		Top	0.299	0.230	0.529
	Bottom	0.400	0.400	0.800		Bottom	0.400	0.400	0.800
	Right	0.188	0.379	0.567		Right	0.032	0.379	0.411
	Left	0.195	0.400	0.595		Left	0.052	0.400	0.452
Simult Tx	Configuration	LTE Band 17 SAR (W/kg)	5 GHz WLAN Ant 2 SAR (W/kg)	Σ SAR (W/kg)	Simult Tx	Configuration	LTE Band 13 SAR (W/kg)	5 GHz WLAN Ant 2 SAR (W/kg)	Σ SAR (W/kg)
Body SAR	Back	0.403	0.037	0.440	Body SAR	Back	0.494	0.037	0.531
	Top	0.177	0.230	0.407		Top	0.241	0.230	0.471
	Bottom	0.400	0.400	0.800		Bottom	0.400	0.400	0.800
	Right	0.115	0.379	0.494		Right	0.173	0.379	0.552
	Left	0.127	0.400	0.527		Left	0.100	0.400	0.500
Simult Tx	Configuration	LTE Band 5 (Cell) SAR (W/kg)	5 GHz WLAN Ant 2 SAR (W/kg)	Σ SAR (W/kg)	Simult Tx	Configuration	LTE Band 4 (AWS) SAR (W/kg)	5 GHz WLAN Ant 2 SAR (W/kg)	Σ SAR (W/kg)
Body SAR	Back	0.512	0.037	0.549	Body SAR	Back	0.617	0.037	0.654
	Top	0.381	0.230	0.611		Top	0.312	0.230	0.542
	Bottom	0.400	0.400	0.800		Bottom	0.400	0.400	0.800
	Right	0.264	0.379	0.643		Right	0.083	0.379	0.462
	Left	0.179	0.400	0.579		Left	0.043	0.400	0.443

Simult Tx	Configuration	LTE Band 25 (PCS) SAR (W/kg)	5 GHz WLAN Ant 2 SAR (W/kg)	Σ SAR (W/kg)
Body SAR	Back	0.566	0.037	0.603
	Top	0.313	0.230	0.543
	Bottom	0.400	0.400	0.800
	Right	0.042	0.379	0.421
	Left	0.035	0.400	0.435





FCC ID: ACJ9TGWW13B	 PCTEST ENGINEERING LABORATORY, INC.	SAR EVALUATION REPORT		Reviewed by: Quality Manager
Document S/N: OY1412152300.ACJ	Test Dates: 12/15/14 - 01/08/15	DUT Type: Wireless Module		Page 75 of 91

Table 11-7
Simultaneous Transmission Scenario with 5 GHz WLAN MIMO (Body at 0 mm)

Simult Tx	Configuration	GPRS 850 SAR (W/kg)	5 GHz WLAN MIMO SAR (W/kg)	Σ SAR (W/kg)	Simult Tx	Configuration	GPRS 1900 SAR (W/kg)	5 GHz WLAN MIMO SAR (W/kg)	Σ SAR (W/kg)
Body SAR	Back	0.455	0.157	0.612	Body SAR	Back	0.470	0.157	0.627
	Top	0.319	0.181	0.500		Top	0.250	0.181	0.431
	Bottom	0.400	0.400	0.800		Bottom	0.400	0.400	0.800
	Right	0.152	0.062	0.214		Right	0.077	0.062	0.139
	Left	0.326	0.120	0.446		Left	0.035	0.120	0.155
Simult Tx	Configuration	UMTS 850 SAR (W/kg)	5 GHz WLAN MIMO SAR (W/kg)	Σ SAR (W/kg)	Simult Tx	Configuration	UMTS 1750 SAR (W/kg)	5 GHz WLAN MIMO SAR (W/kg)	Σ SAR (W/kg)
Body SAR	Back	0.486	0.157	0.643	Body SAR	Back	0.497	0.157	0.654
	Top	0.346	0.181	0.527		Top	0.302	0.181	0.483
	Bottom	0.400	0.400	0.800		Bottom	0.400	0.400	0.800
	Right	0.177	0.062	0.239		Right	0.075	0.062	0.137
	Left	0.171	0.120	0.291		Left	0.126	0.120	0.246
Simult Tx	Configuration	UMTS 1900 SAR (W/kg)	5 GHz WLAN MIMO SAR (W/kg)	Σ SAR (W/kg)	Simult Tx	Configuration	EVDO BC10 (\$90S) SAR (W/kg)	5 GHz WLAN MIMO SAR (W/kg)	Σ SAR (W/kg)
Body SAR	Back	0.606	0.157	0.763	Body SAR	Back	0.632	0.157	0.789
	Top	0.380	0.181	0.561		Top	0.343	0.181	0.524
	Bottom	0.400	0.400	0.800		Bottom	0.400	0.400	0.800
	Right	0.033	0.062	0.095		Right	0.207	0.062	0.269
	Left	0.043	0.120	0.163		Left	0.201	0.120	0.321
Simult Tx	Configuration	EVDO BC0 (\$22H) SAR (W/kg)	5 GHz WLAN MIMO SAR (W/kg)	Σ SAR (W/kg)	Simult Tx	Configuration	PCS EVDO SAR (W/kg)	5 GHz WLAN MIMO SAR (W/kg)	Σ SAR (W/kg)
Body SAR	Back	0.700	0.157	0.857	Body SAR	Back	0.555	0.157	0.712
	Top	0.424	0.181	0.605		Top	0.299	0.181	0.480
	Bottom	0.400	0.400	0.800		Bottom	0.400	0.400	0.800
	Right	0.188	0.062	0.250		Right	0.032	0.062	0.094
	Left	0.195	0.120	0.315		Left	0.052	0.120	0.172
Simult Tx	Configuration	LTE Band 17 SAR (W/kg)	5 GHz WLAN MIMO SAR (W/kg)	Σ SAR (W/kg)	Simult Tx	Configuration	LTE Band 13 SAR (W/kg)	5 GHz WLAN MIMO SAR (W/kg)	Σ SAR (W/kg)
Body SAR	Back	0.403	0.157	0.560	Body SAR	Back	0.494	0.157	0.651
	Top	0.177	0.181	0.358		Top	0.241	0.181	0.422
	Bottom	0.400	0.400	0.800		Bottom	0.400	0.400	0.800
	Right	0.115	0.062	0.177		Right	0.173	0.062	0.235
	Left	0.127	0.120	0.247		Left	0.100	0.120	0.220
Simult Tx	Configuration	LTE Band 5 (Cell) SAR (W/kg)	5 GHz WLAN MIMO SAR (W/kg)	Σ SAR (W/kg)	Simult Tx	Configuration	LTE Band 4 (AWS) SAR (W/kg)	5 GHz WLAN MIMO SAR (W/kg)	Σ SAR (W/kg)
Body SAR	Back	0.512	0.157	0.669	Body SAR	Back	0.617	0.157	0.774
	Top	0.381	0.181	0.562		Top	0.312	0.181	0.493
	Bottom	0.400	0.400	0.800		Bottom	0.400	0.400	0.800
	Right	0.264	0.062	0.326		Right	0.083	0.062	0.145
	Left	0.179	0.120	0.299		Left	0.043	0.120	0.163

Simult Tx	Configuration	LTE Band 25 (PCS) SAR (W/kg)	5 GHz WLAN MIMO SAR (W/kg)	Σ SAR (W/kg)
Body SAR	Back	0.566	0.157	0.723
	Top	0.313	0.181	0.494
	Bottom	0.400	0.400	0.800
	Right	0.042	0.062	0.104
	Left	0.035	0.120	0.155

FCC ID: ACJ9TGWW13B		SAR EVALUATION REPORT		Reviewed by: Quality Manager
Document S/N: OY1412152300.ACJ	Test Dates: 12/15/14 - 01/08/15	DUT Type: Wireless Module	Page 76 of 91	

**Table 11-8
Simultaneous Transmission Scenario with Bluetooth (Body at 0 mm)**

Simult Tx	Configuration	GPRS 850 SAR (W/kg)	Bluetooth SAR (W/kg)	Σ SAR (W/kg)	Simult Tx	Configuration	GPRS 1900 SAR (W/kg)	Bluetooth SAR (W/kg)	Σ SAR (W/kg)
Body SAR	Back	0.455	0.000	0.455	Body SAR	Back	0.470	0.000	0.470
	Top	0.319	0.033	0.352		Top	0.250	0.033	0.283
	Bottom	0.400	0.400	0.800		Bottom	0.400	0.400	0.800
	Right	0.152	0.016	0.168		Right	0.077	0.016	0.093
	Left	0.326	0.400	0.726		Left	0.035	0.400	0.435
Simult Tx	Configuration	UMTS 850 SAR (W/kg)	Bluetooth SAR (W/kg)	Σ SAR (W/kg)	Simult Tx	Configuration	UMTS 1750 SAR (W/kg)	Bluetooth SAR (W/kg)	Σ SAR (W/kg)
Body SAR	Back	0.486	0.000	0.486	Body SAR	Back	0.497	0.000	0.497
	Top	0.346	0.033	0.379		Top	0.302	0.033	0.335
	Bottom	0.400	0.400	0.800		Bottom	0.400	0.400	0.800
	Right	0.177	0.016	0.193		Right	0.075	0.016	0.091
	Left	0.171	0.400	0.571		Left	0.126	0.400	0.526
Simult Tx	Configuration	UMTS 1900 SAR (W/kg)	Bluetooth SAR (W/kg)	Σ SAR (W/kg)	Simult Tx	Configuration	EVDO BC10 (\$90S) SAR (W/kg)	Bluetooth SAR (W/kg)	Σ SAR (W/kg)
Body SAR	Back	0.606	0.000	0.606	Body SAR	Back	0.632	0.000	0.632
	Top	0.380	0.033	0.413		Top	0.343	0.033	0.376
	Bottom	0.400	0.400	0.800		Bottom	0.400	0.400	0.800
	Right	0.033	0.016	0.049		Right	0.207	0.016	0.223
	Left	0.043	0.400	0.443		Left	0.201	0.400	0.601
Simult Tx	Configuration	EVDO BC0 (\$22H) SAR (W/kg)	Bluetooth SAR (W/kg)	Σ SAR (W/kg)	Simult Tx	Configuration	PCS EVDO SAR (W/kg)	Bluetooth SAR (W/kg)	Σ SAR (W/kg)
Body SAR	Back	0.700	0.000	0.700	Body SAR	Back	0.555	0.000	0.555
	Top	0.424	0.033	0.457		Top	0.299	0.033	0.332
	Bottom	0.400	0.400	0.800		Bottom	0.400	0.400	0.800
	Right	0.188	0.016	0.204		Right	0.032	0.016	0.048
	Left	0.195	0.400	0.595		Left	0.052	0.400	0.452
Simult Tx	Configuration	LTE Band 17 SAR (W/kg)	Bluetooth SAR (W/kg)	Σ SAR (W/kg)	Simult Tx	Configuration	LTE Band 13 SAR (W/kg)	Bluetooth SAR (W/kg)	Σ SAR (W/kg)
Body SAR	Back	0.403	0.000	0.403	Body SAR	Back	0.494	0.000	0.494
	Top	0.177	0.033	0.210		Top	0.241	0.033	0.274
	Bottom	0.400	0.400	0.800		Bottom	0.400	0.400	0.800
	Right	0.115	0.016	0.131		Right	0.173	0.016	0.189
	Left	0.127	0.400	0.527		Left	0.100	0.400	0.500
Simult Tx	Configuration	LTE Band 5 (Cell) SAR (W/kg)	Bluetooth SAR (W/kg)	Σ SAR (W/kg)	Simult Tx	Configuration	LTE Band 4 (AWS) SAR (W/kg)	Bluetooth SAR (W/kg)	Σ SAR (W/kg)
Body SAR	Back	0.512	0.000	0.512	Body SAR	Back	0.617	0.000	0.617
	Top	0.381	0.033	0.414		Top	0.312	0.033	0.345
	Bottom	0.400	0.400	0.800		Bottom	0.400	0.400	0.800
	Right	0.264	0.016	0.280		Right	0.083	0.016	0.099
	Left	0.179	0.400	0.579		Left	0.043	0.400	0.443

Simult Tx	Configuration	LTE Band 25 (PCS) SAR (W/kg)	Bluetooth SAR (W/kg)	Σ SAR (W/kg)
Body SAR	Back	0.566	0.000	0.566
	Top	0.313	0.033	0.346
	Bottom	0.400	0.400	0.800
	Right	0.042	0.016	0.058
	Left	0.035	0.400	0.435



FCC ID: ACJ9TGWW13B		SAR EVALUATION REPORT		Reviewed by: Quality Manager
Document S/N: 0Y1412152300.ACJ	Test Dates: 12/15/14 - 01/08/15	DUT Type: Wireless Module	Page 77 of 91	

Table 11-9
Simultaneous Transmission Scenario with 2.4 GHz WLAN Antenna 1 (Back at 18 mm)

Configuration	Mode	2G/3G/4G SAR (W/kg)	2.4 GHz WLAN Ant 1 SAR (W/kg)	Σ SAR (W/kg)
Back Side	GPRS 850	0.547	<0.223	<0.770
Back Side	GPRS 1900	0.489	<0.223	<0.712
Back Side	UMTS 850	0.279	<0.223	<0.502
Back Side	UMTS 1750	0.625	<0.223	<0.848
Back Side	UMTS 1900	0.599	<0.223	<0.822
Back Side	EVDO BC10 (\$90S)	0.367	<0.223	<0.590
Back Side	EVDO BC0 (\$22H)	0.407	<0.223	<0.630
Back Side	PCS EVDO	0.849	<0.223	<1.072
Back Side	LTE Band 17	0.268	<0.223	<0.491
Back Side	LTE Band 13	0.293	<0.223	<0.516
Back Side	LTE Band 5 (Cell)	0.350	<0.223	<0.573
Back Side	LTE Band 4 (AWS)	0.737	<0.223	<0.960
Back Side	LTE Band 25 (PCS)	1.007	<0.223	<1.230

Table 11-10
Simultaneous Transmission Scenario with 2.4 GHz WLAN Antenna 2 (Back at 18 mm)

Configuration	Mode	2G/3G/4G SAR (W/kg)	2.4 GHz WLAN Ant 2 SAR (W/kg)	Σ SAR (W/kg)
Back Side	GPRS 850	0.547	<0.025	<0.572
Back Side	GPRS 1900	0.489	<0.025	<0.514
Back Side	UMTS 850	0.279	<0.025	<0.304
Back Side	UMTS 1750	0.625	<0.025	<0.650
Back Side	UMTS 1900	0.599	<0.025	<0.624
Back Side	EVDO BC10 (\$90S)	0.367	<0.025	<0.392
Back Side	EVDO BC0 (\$22H)	0.407	<0.025	<0.432
Back Side	PCS EVDO	0.849	<0.025	<0.874
Back Side	LTE Band 17	0.268	<0.025	<0.293
Back Side	LTE Band 13	0.293	<0.025	<0.318
Back Side	LTE Band 5 (Cell)	0.350	<0.025	<0.375
Back Side	LTE Band 4 (AWS)	0.737	<0.025	<0.762
Back Side	LTE Band 25 (PCS)	1.007	<0.025	<1.032

Table 11-11
Simultaneous Transmission Scenario with 2.4 GHz WLAN MIMO (Back at 18 mm)

Configuration	Mode	2G/3G/4G SAR (W/kg)	2.4 GHz WLAN MIMO SAR (W/kg)	Σ SAR (W/kg)
Back Side	GPRS 850	0.547	<0.155	<0.702
Back Side	GPRS 1900	0.489	<0.155	<0.644
Back Side	UMTS 850	0.279	<0.155	<0.434
Back Side	UMTS 1750	0.625	<0.155	<0.780
Back Side	UMTS 1900	0.599	<0.155	<0.754
Back Side	EVDO BC10 (\$90S)	0.367	<0.155	<0.522
Back Side	EVDO BC0 (\$22H)	0.407	<0.155	<0.562
Back Side	PCS EVDO	0.849	<0.155	<1.004
Back Side	LTE Band 17	0.268	<0.155	<0.423
Back Side	LTE Band 13	0.293	<0.155	<0.448
Back Side	LTE Band 5 (Cell)	0.350	<0.155	<0.505
Back Side	LTE Band 4 (AWS)	0.737	<0.155	<0.892
Back Side	LTE Band 25 (PCS)	1.007	<0.155	<1.162



FCC ID: ACJ9TGWW13B		SAR EVALUATION REPORT		Reviewed by: Quality Manager
Document S/N: OY1412152300.ACJ	Test Dates: 12/15/14 - 01/08/15	DUT Type: Wireless Module		Page 78 of 91

Table 11-12
Simultaneous Transmission Scenario with 5 GHz WLAN Antenna 1 (Back at 18 mm)

Configuration	Mode	2G/3G/4G SAR (W/kg)	5 GHz WLAN Ant 1 SAR (W/kg)	Σ SAR (W/kg)
Back Side	GPRS 850	0.547	<0.568	<1.115
Back Side	GPRS 1900	0.489	<0.568	<1.057
Back Side	UMTS 850	0.279	<0.568	<0.847
Back Side	UMTS 1750	0.625	<0.568	<1.193
Back Side	UMTS 1900	0.599	<0.568	<1.167
Back Side	EVDO BC10 (§90S)	0.367	<0.568	<0.935
Back Side	EVDO BC0 (§22H)	0.407	<0.568	<0.975
Back Side	PCS EVDO	0.849	<0.568	<1.417
Back Side	LTE Band 17	0.268	<0.568	<0.836
Back Side	LTE Band 13	0.293	<0.568	<0.861
Back Side	LTE Band 5 (Cell)	0.350	<0.568	<0.918
Back Side	LTE Band 4 (AWS)	0.737	<0.568	<1.305
Back Side	LTE Band 25 (PCS)	1.007	<0.568	<1.575

Table 11-13
Simultaneous Transmission Scenario with 5 GHz WLAN Antenna 2 (Back at 18 mm)

Configuration	Mode	2G/3G/4G SAR (W/kg)	5 GHz WLAN Ant 2 SAR (W/kg)	Σ SAR (W/kg)
Back Side	GPRS 850	0.547	<0.037	<0.584
Back Side	GPRS 1900	0.489	<0.037	<0.526
Back Side	UMTS 850	0.279	<0.037	<0.316
Back Side	UMTS 1750	0.625	<0.037	<0.662
Back Side	UMTS 1900	0.599	<0.037	<0.636
Back Side	EVDO BC10 (§90S)	0.367	<0.037	<0.404
Back Side	EVDO BC0 (§22H)	0.407	<0.037	<0.444
Back Side	PCS EVDO	0.849	<0.037	<0.886
Back Side	LTE Band 17	0.268	<0.037	<0.305
Back Side	LTE Band 13	0.293	<0.037	<0.330
Back Side	LTE Band 5 (Cell)	0.350	<0.037	<0.387
Back Side	LTE Band 4 (AWS)	0.737	<0.037	<0.774
Back Side	LTE Band 25 (PCS)	1.007	<0.037	<1.044

Table 11-14
Simultaneous Transmission Scenario with 5 GHz WLAN MIMO (Back at 18 mm)

Configuration	Mode	2G/3G/4G SAR (W/kg)	5 GHz WLAN MIMO SAR (W/kg)	Σ SAR (W/kg)
Back Side	GPRS 850	0.547	<0.157	<0.704
Back Side	GPRS 1900	0.489	<0.157	<0.646
Back Side	UMTS 850	0.279	<0.157	<0.436
Back Side	UMTS 1750	0.625	<0.157	<0.782
Back Side	UMTS 1900	0.599	<0.157	<0.756
Back Side	EVDO BC10 (§90S)	0.367	<0.157	<0.524
Back Side	EVDO BC0 (§22H)	0.407	<0.157	<0.564
Back Side	PCS EVDO	0.849	<0.157	<1.006
Back Side	LTE Band 17	0.268	<0.157	<0.425
Back Side	LTE Band 13	0.293	<0.157	<0.450
Back Side	LTE Band 5 (Cell)	0.350	<0.157	<0.507
Back Side	LTE Band 4 (AWS)	0.737	<0.157	<0.894
Back Side	LTE Band 25 (PCS)	1.007	<0.157	<1.164



FCC ID: ACJ9TGWW13B		SAR EVALUATION REPORT		Reviewed by: Quality Manager
Document S/N: OY1412152300.ACJ	Test Dates: 12/15/14 - 01/08/15	DUT Type: Wireless Module		Page 79 of 91

Table 11-15
Simultaneous Transmission Scenario with Bluetooth (Back at 18 mm)

Configuration	Mode	2G/3G/4G SAR (W/kg)	Bluetooth SAR (W/kg)	Σ SAR (W/kg)
Back Side	GPRS 850	0.547	0.000	0.547
Back Side	GPRS 1900	0.489	0.000	0.489
Back Side	UMTS 850	0.279	0.000	0.279
Back Side	UMTS 1750	0.625	0.000	0.625
Back Side	UMTS 1900	0.599	0.000	0.599
Back Side	EVDO BC10 (\$90S)	0.367	0.000	0.367
Back Side	EVDO BC0 (\$22H)	0.407	0.000	0.407
Back Side	PCS EVDO	0.849	0.000	0.849
Back Side	LTE Band 17	0.268	0.000	0.268
Back Side	LTE Band 13	0.293	0.000	0.293
Back Side	LTE Band 5 (Cell)	0.350	0.000	0.350
Back Side	LTE Band 4 (AWS)	0.737	0.000	0.737
Back Side	LTE Band 25 (PCS)	1.007	0.000	1.007

Table 11-16
Simultaneous Transmission Scenario with 2.4 GHz WLAN Antenna 1 (Top at 16 mm)

Configuration	Mode	2G/3G/4G SAR (W/kg)	2.4 GHz WLAN Ant 1 SAR (W/kg)	Σ SAR (W/kg)
Top Edge	GPRS 850	0.448	<0.129	<0.577
Top Edge	GPRS 1900	0.793	<0.129	<0.922
Top Edge	UMTS 850	0.293	<0.129	<0.422
Top Edge	UMTS 1750	0.774	<0.129	<0.903
Top Edge	UMTS 1900	1.128	<0.129	<1.257
Top Edge	EVDO BC10 (\$90S)	0.317	<0.129	<0.446
Top Edge	EVDO BC0 (\$22H)	0.399	<0.129	<0.528
Top Edge	PCS EVDO	1.028	<0.129	<1.157
Top Edge	LTE Band 17	0.214	<0.129	<0.343
Top Edge	LTE Band 13	0.289	<0.129	<0.418
Top Edge	LTE Band 5 (Cell)	0.311	<0.129	<0.440
Top Edge	LTE Band 4 (AWS)	0.986	<0.129	<1.115
Top Edge	LTE Band 25 (PCS)	1.001	<0.129	<1.130

Table 11-17
Simultaneous Transmission Scenario with 2.4 GHz WLAN Antenna 2 (Top at 16 mm)

Configuration	Mode	2G/3G/4G SAR (W/kg)	2.4 GHz WLAN Ant 2 SAR (W/kg)	Σ SAR (W/kg)
Top Edge	GPRS 850	0.448	<0.117	<0.565
Top Edge	GPRS 1900	0.793	<0.117	<0.910
Top Edge	UMTS 850	0.293	<0.117	<0.410
Top Edge	UMTS 1750	0.774	<0.117	<0.891
Top Edge	UMTS 1900	1.128	<0.117	<1.245
Top Edge	EVDO BC10 (\$90S)	0.317	<0.117	<0.434
Top Edge	EVDO BC0 (\$22H)	0.399	<0.117	<0.516
Top Edge	PCS EVDO	1.028	<0.117	<1.145
Top Edge	LTE Band 17	0.214	<0.117	<0.331
Top Edge	LTE Band 13	0.289	<0.117	<0.406
Top Edge	LTE Band 5 (Cell)	0.311	<0.117	<0.428
Top Edge	LTE Band 4 (AWS)	0.986	<0.117	<1.103
Top Edge	LTE Band 25 (PCS)	1.001	<0.117	<1.118



FCC ID: ACJ9TGWW13B		SAR EVALUATION REPORT		Reviewed by: Quality Manager
Document S/N: OY1412152300.ACJ	Test Dates: 12/15/14 - 01/08/15	DUT Type: Wireless Module		Page 80 of 91

Table 11-18
Simultaneous Transmission Scenario with 2.4 GHz WLAN MIMO (Top at 16 mm)

Configuration	Mode	2G/3G/4G SAR (W/kg)	2.4 GHz WLAN MIMO SAR (W/kg)	Σ SAR (W/kg)
Top Edge	GPRS 850	0.448	<0.083	<0.531
Top Edge	GPRS 1900	0.793	<0.083	<0.876
Top Edge	UMTS 850	0.293	<0.083	<0.376
Top Edge	UMTS 1750	0.774	<0.083	<0.857
Top Edge	UMTS 1900	1.128	<0.083	<1.211
Top Edge	EVDO BC10 (§90S)	0.317	<0.083	<0.400
Top Edge	EVDO BC0 (§22H)	0.399	<0.083	<0.482
Top Edge	PCS EVDO	1.028	<0.083	<1.111
Top Edge	LTE Band 17	0.214	<0.083	<0.297
Top Edge	LTE Band 13	0.289	<0.083	<0.372
Top Edge	LTE Band 5 (Cell)	0.311	<0.083	<0.394
Top Edge	LTE Band 4 (AWS)	0.986	<0.083	<1.069
Top Edge	LTE Band 25 (PCS)	1.001	<0.083	<1.084

Table 11-19
Simultaneous Transmission Scenario with 5 GHz WLAN Antenna 1 (Top at 16 mm)

Configuration	Mode	2G/3G/4G SAR (W/kg)	5 GHz WLAN Ant 1 SAR (W/kg)	Σ SAR (W/kg)
Top Edge	GPRS 850	0.448	<0.347	<0.795
Top Edge	GPRS 1900	0.793	<0.347	<1.140
Top Edge	UMTS 850	0.293	<0.347	<0.640
Top Edge	UMTS 1750	0.774	<0.347	<1.121
Top Edge	UMTS 1900	1.128	<0.347	<1.475
Top Edge	EVDO BC10 (§90S)	0.317	<0.347	<0.664
Top Edge	EVDO BC0 (§22H)	0.399	<0.347	<0.746
Top Edge	PCS EVDO	1.028	<0.347	<1.375
Top Edge	LTE Band 17	0.214	<0.347	<0.561
Top Edge	LTE Band 13	0.289	<0.347	<0.636
Top Edge	LTE Band 5 (Cell)	0.311	<0.347	<0.658
Top Edge	LTE Band 4 (AWS)	0.986	<0.347	<1.333
Top Edge	LTE Band 25 (PCS)	1.001	<0.347	<1.348

Table 11-20
Simultaneous Transmission Scenario with 5 GHz WLAN Antenna 2 (Top at 16 mm)

Configuration	Mode	2G/3G/4G SAR (W/kg)	5 GHz WLAN Ant 2 SAR (W/kg)	Σ SAR (W/kg)
Top Edge	GPRS 850	0.448	<0.230	<0.678
Top Edge	GPRS 1900	0.793	<0.230	<1.023
Top Edge	UMTS 850	0.293	<0.230	<0.523
Top Edge	UMTS 1750	0.774	<0.230	<1.004
Top Edge	UMTS 1900	1.128	<0.230	<1.358
Top Edge	EVDO BC10 (§90S)	0.317	<0.230	<0.547
Top Edge	EVDO BC0 (§22H)	0.399	<0.230	<0.629
Top Edge	PCS EVDO	1.028	<0.230	<1.258
Top Edge	LTE Band 17	0.214	<0.230	<0.444
Top Edge	LTE Band 13	0.289	<0.230	<0.519
Top Edge	LTE Band 5 (Cell)	0.311	<0.230	<0.541
Top Edge	LTE Band 4 (AWS)	0.986	<0.230	<1.216
Top Edge	LTE Band 25 (PCS)	1.001	<0.230	<1.231



FCC ID: ACJ9TGWW13B		SAR EVALUATION REPORT		Reviewed by: Quality Manager
Document S/N: OY1412152300.ACJ	Test Dates: 12/15/14 - 01/08/15	DUT Type: Wireless Module		Page 81 of 91

Table 11-21
Simultaneous Transmission Scenario with 5 GHz WLAN MIMO (Top at 16 mm)

Configuration	Mode	2G/3G/4G SAR (W/kg)	5 GHz WLAN MIMO SAR (W/kg)	Σ SAR (W/kg)
Top Edge	GPRS 850	0.448	<0.181	<0.629
Top Edge	GPRS 1900	0.793	<0.181	<0.974
Top Edge	UMTS 850	0.293	<0.181	<0.474
Top Edge	UMTS 1750	0.774	<0.181	<0.955
Top Edge	UMTS 1900	1.128	<0.181	<1.309
Top Edge	EVDO BC10 (§90S)	0.317	<0.181	<0.498
Top Edge	EVDO BC0 (§22H)	0.399	<0.181	<0.580
Top Edge	PCS EVDO	1.028	<0.181	<1.209
Top Edge	LTE Band 17	0.214	<0.181	<0.395
Top Edge	LTE Band 13	0.289	<0.181	<0.470
Top Edge	LTE Band 5 (Cell)	0.311	<0.181	<0.492
Top Edge	LTE Band 4 (AWS)	0.986	<0.181	<1.167
Top Edge	LTE Band 25 (PCS)	1.001	<0.181	<1.182

Table 11-22
Simultaneous Transmission Scenario with Bluetooth (Top at 16 mm)

Configuration	Mode	2G/3G/4G SAR (W/kg)	Bluetooth SAR (W/kg)	Σ SAR (W/kg)
Top Edge	GPRS 850	0.448	<0.033	<0.481
Top Edge	GPRS 1900	0.793	<0.033	<0.826
Top Edge	UMTS 850	0.293	<0.033	<0.326
Top Edge	UMTS 1750	0.774	<0.033	<0.807
Top Edge	UMTS 1900	1.128	<0.033	<1.161
Top Edge	EVDO BC10 (§90S)	0.317	<0.033	<0.350
Top Edge	EVDO BC0 (§22H)	0.399	<0.033	<0.432
Top Edge	PCS EVDO	1.028	<0.033	<1.061
Top Edge	LTE Band 17	0.214	<0.033	<0.247
Top Edge	LTE Band 13	0.289	<0.033	<0.322
Top Edge	LTE Band 5 (Cell)	0.311	<0.033	<0.344
Top Edge	LTE Band 4 (AWS)	0.986	<0.033	<1.019
Top Edge	LTE Band 25 (PCS)	1.001	<0.033	<1.034

Table 11-23
Simultaneous Transmission Scenario with 2.4 GHz WLAN Antenna 1 (Right at 3 mm)

Configuration	Mode	2G/3G/4G SAR (W/kg)	2.4 GHz WLAN Ant 1 SAR (W/kg)	Σ SAR (W/kg)
Right Edge	GPRS 850	0.967	0.400	1.367
Right Edge	GPRS 1900	0.395	0.400	0.795
Right Edge	UMTS 850	0.430	0.400	0.830
Right Edge	UMTS 1750	0.486	0.400	0.886
Right Edge	UMTS 1900	0.286	0.400	0.686
Right Edge	EVDO BC10 (§90S)	0.118	0.400	0.518
Right Edge	EVDO BC0 (§22H)	0.110	0.400	0.510
Right Edge	PCS EVDO	0.412	0.400	0.812
Right Edge	LTE Band 17	0.326	0.400	0.726
Right Edge	LTE Band 13	0.307	0.400	0.707
Right Edge	LTE Band 5 (Cell)	0.475	0.400	0.875
Right Edge	LTE Band 4 (AWS)	0.834	0.400	1.234
Right Edge	LTE Band 25 (PCS)	0.365	0.400	0.765



FCC ID: ACJ9TGWW13B		SAR EVALUATION REPORT		Reviewed by: Quality Manager
Document S/N: OY1412152300.ACJ	Test Dates: 12/15/14 - 01/08/15	DUT Type: Wireless Module		Page 82 of 91

Table 11-24
Simultaneous Transmission Scenario with 2.4 GHz WLAN Antenna 2 (Right at 3 mm)

Configuration	Mode	2G/3G/4G SAR (W/kg)	2.4 GHz WLAN Ant 2 SAR (W/kg)	Σ SAR (W/kg)
Right Edge	GPRS 850	0.967	<0.144	<1.111
Right Edge	GPRS 1900	0.395	<0.144	<0.539
Right Edge	UMTS 850	0.430	<0.144	<0.574
Right Edge	UMTS 1750	0.486	<0.144	<0.630
Right Edge	UMTS 1900	0.286	<0.144	<0.430
Right Edge	EVDO BC10 (\$90S)	0.118	<0.144	<0.262
Right Edge	EVDO BC0 (\$22H)	0.110	<0.144	<0.254
Right Edge	PCS EVDO	0.412	<0.144	<0.556
Right Edge	LTE Band 17	0.326	<0.144	<0.470
Right Edge	LTE Band 13	0.307	<0.144	<0.451
Right Edge	LTE Band 5 (Cell)	0.475	<0.144	<0.619
Right Edge	LTE Band 4 (AWS)	0.834	<0.144	<0.978
Right Edge	LTE Band 25 (PCS)	0.365	<0.144	<0.509

Table 11-25
Simultaneous Transmission Scenario with 2.4 GHz WLAN MIMO (Right at 3 mm)

Configuration	Mode	2G/3G/4G SAR (W/kg)	2.4 GHz WLAN MIMO SAR (W/kg)	Σ SAR (W/kg)
Right Edge	GPRS 850	0.967	<0.068	<1.035
Right Edge	GPRS 1900	0.395	<0.068	<0.463
Right Edge	UMTS 850	0.430	<0.068	<0.498
Right Edge	UMTS 1750	0.486	<0.068	<0.554
Right Edge	UMTS 1900	0.286	<0.068	<0.354
Right Edge	EVDO BC10 (\$90S)	0.118	<0.068	<0.186
Right Edge	EVDO BC0 (\$22H)	0.110	<0.068	<0.178
Right Edge	PCS EVDO	0.412	<0.068	<0.480
Right Edge	LTE Band 17	0.326	<0.068	<0.394
Right Edge	LTE Band 13	0.307	<0.068	<0.375
Right Edge	LTE Band 5 (Cell)	0.475	<0.068	<0.543
Right Edge	LTE Band 4 (AWS)	0.834	<0.068	<0.902
Right Edge	LTE Band 25 (PCS)	0.365	<0.068	<0.433

Table 11-26
Simultaneous Transmission Scenario with 5 GHz WLAN Antenna 1 (Right at 3 mm)

Configuration	Mode	2G/3G/4G SAR (W/kg)	5 GHz WLAN Ant 1 SAR (W/kg)	Σ SAR (W/kg)
Right Edge	GPRS 850	0.967	0.400	1.367
Right Edge	GPRS 1900	0.395	0.400	0.795
Right Edge	UMTS 850	0.430	0.400	0.830
Right Edge	UMTS 1750	0.486	0.400	0.886
Right Edge	UMTS 1900	0.286	0.400	0.686
Right Edge	EVDO BC10 (\$90S)	0.118	0.400	0.518
Right Edge	EVDO BC0 (\$22H)	0.110	0.400	0.510
Right Edge	PCS EVDO	0.412	0.400	0.812
Right Edge	LTE Band 17	0.326	0.400	0.726
Right Edge	LTE Band 13	0.307	0.400	0.707
Right Edge	LTE Band 5 (Cell)	0.475	0.400	0.875
Right Edge	LTE Band 4 (AWS)	0.834	0.400	1.234
Right Edge	LTE Band 25 (PCS)	0.365	0.400	0.765



FCC ID: ACJ9TGWW13B		SAR EVALUATION REPORT		Reviewed by: Quality Manager
Document S/N: OY1412152300.ACJ	Test Dates: 12/15/14 - 01/08/15	DUT Type: Wireless Module		Page 83 of 91

Table 11-27
Simultaneous Transmission Scenario with 5 GHz WLAN Antenna 2 (Right at 3 mm)



Configuration	Mode	2G/3G/4G SAR (W/kg)	5 GHz WLAN Ant 2 SAR (W/kg)	Σ SAR (W/kg)
Right Edge	GPRS 850	0.967	<0.379	<1.346
Right Edge	GPRS 1900	0.395	<0.379	<0.774
Right Edge	UMTS 850	0.430	<0.379	<0.809
Right Edge	UMTS 1750	0.486	<0.379	<0.865
Right Edge	UMTS 1900	0.286	<0.379	<0.665
Right Edge	EVDO BC10 (\$90S)	0.118	<0.379	<0.497
Right Edge	EVDO BC0 (\$22H)	0.110	<0.379	<0.489
Right Edge	PCS EVDO	0.412	<0.379	<0.791
Right Edge	LTE Band 17	0.326	<0.379	<0.705
Right Edge	LTE Band 13	0.307	<0.379	<0.686
Right Edge	LTE Band 5 (Cell)	0.475	<0.379	<0.854
Right Edge	LTE Band 4 (AWS)	0.834	<0.379	<1.213
Right Edge	LTE Band 25 (PCS)	0.365	<0.379	<0.744

Table 11-28
Simultaneous Transmission Scenario with 5 GHz WLAN MIMO (Right at 3 mm)

Configuration	Mode	2G/3G/4G SAR (W/kg)	5 GHz WLAN MIMO SAR (W/kg)	Σ SAR (W/kg)
Right Edge	GPRS 850	0.967	<0.062	<1.029
Right Edge	GPRS 1900	0.395	<0.062	<0.457
Right Edge	UMTS 850	0.430	<0.062	<0.492
Right Edge	UMTS 1750	0.486	<0.062	<0.548
Right Edge	UMTS 1900	0.286	<0.062	<0.348
Right Edge	EVDO BC10 (\$90S)	0.118	<0.062	<0.180
Right Edge	EVDO BC0 (\$22H)	0.110	<0.062	<0.172
Right Edge	PCS EVDO	0.412	<0.062	<0.474
Right Edge	LTE Band 17	0.326	<0.062	<0.388
Right Edge	LTE Band 13	0.307	<0.062	<0.369
Right Edge	LTE Band 5 (Cell)	0.475	<0.062	<0.537
Right Edge	LTE Band 4 (AWS)	0.834	<0.062	<0.896
Right Edge	LTE Band 25 (PCS)	0.365	<0.062	<0.427

Table 11-29
Simultaneous Transmission Scenario with Bluetooth (Right at 3 mm)



Configuration	Mode	2G/3G/4G SAR (W/kg)	Bluetooth SAR (W/kg)	Σ SAR (W/kg)
Right Edge	GPRS 850	0.967	<0.016	<0.983
Right Edge	GPRS 1900	0.395	<0.016	<0.411
Right Edge	UMTS 850	0.430	<0.016	<0.446
Right Edge	UMTS 1750	0.486	<0.016	<0.502
Right Edge	UMTS 1900	0.286	<0.016	<0.302
Right Edge	EVDO BC10 (\$90S)	0.118	<0.016	<0.134
Right Edge	EVDO BC0 (\$22H)	0.110	<0.016	<0.126
Right Edge	PCS EVDO	0.412	<0.016	<0.428
Right Edge	LTE Band 17	0.326	<0.016	<0.342
Right Edge	LTE Band 13	0.307	<0.016	<0.323
Right Edge	LTE Band 5 (Cell)	0.475	<0.016	<0.491
Right Edge	LTE Band 4 (AWS)	0.834	<0.016	<0.850
Right Edge	LTE Band 25 (PCS)	0.365	<0.016	<0.381

FCC ID: ACJ9TGWW13B		SAR EVALUATION REPORT		Reviewed by: Quality Manager
Document S/N: OY1412152300.ACJ	Test Dates: 12/15/14 - 01/08/15	DUT Type: Wireless Module		Page 84 of 91

1. For configurations excluded per 447498 D01v05, an estimated SAR of 0.4 W/kg was used to determine simultaneous transmission SAR exclusion when the test separation distance was >50 mm.
2. For SAR summations for body back at 18 mm, WLAN and Bluetooth SAR values for 0.0 cm were used since the 0.0 cm test distance for WLAN and Bluetooth was more conservative. "<" denotes that the 0.0 cm WLAN or Bluetooth SAR values were used for summation purposes.
3. For SAR summations for body top at 16 mm, WLAN and Bluetooth SAR values for 0.0 cm were used since the 0.0 cm test distance for WLAN and Bluetooth was more conservative. "<" denotes that the 0.0 cm WLAN or Bluetooth SAR values were used for summation purposes.
4. For SAR summations for body right at 3 mm, WLAN and Bluetooth SAR values for 0.0 cm were used since the 0.0 cm test distance for WLAN and Bluetooth was more conservative. "<" denotes that the 0.0 cm WLAN or Bluetooth SAR values were used for summation purposes.
5. Only WLAN antenna 2 is capable of transmitting Bluetooth.

11.4 Simultaneous Transmission Conclusion

The above numerical summed SAR results for all the worst-case simultaneous transmission conditions were below the SAR limit. Therefore, the above analysis is sufficient to determine that simultaneous transmission cases will not exceed the SAR limit and therefore no measured volumetric simultaneous SAR summation is required per FCC KDB Publication 447498 D01v05 and IEEE 1528-2013 Section 6.3.4.1.2.

FCC ID: ACJ9TGWW13B		SAR EVALUATION REPORT		Reviewed by: Quality Manager
Document S/N: OY1412152300.ACJ	Test Dates: 12/15/14 - 01/08/15	DUT Type: Wireless Module		Page 85 of 91

12 SAR MEASUREMENT VARIABILITY

12.1 Measurement Variability

Per FCC KDB Publication 865664 D01v01, SAR measurement variability was assessed for each frequency band, which was determined by the SAR probe calibration point and tissue-equivalent medium used for the device measurements. When both head and body tissue-equivalent media were required for SAR measurements in a frequency band, the variability measurement procedures were applied to the tissue medium with the highest measured SAR, using the highest measured SAR configuration for that tissue-equivalent medium. These additional measurements were repeated after the completion of all measurements requiring the same head or body tissue-equivalent medium in a frequency band. The test device was returned to ambient conditions (normal room temperature) with the battery fully charged before it was re-mounted on the device holder for the repeated measurement(s) to minimize any unexpected variations in the repeated results.

SAR Measurement Variability was assessed using the following procedures for each frequency band:



- 1) When the original highest measured SAR is ≥ 0.80 W/kg, the measurement was repeated once.
- 2) A second repeated measurement was performed only if the ratio of largest to smallest SAR for the original and first repeated measurements was > 1.20 or when the original or repeated measurement was ≥ 1.45 W/kg (~ 10% from the 1-g SAR limit).
- 3) A third repeated measurement was performed only if the original, first or second repeated measurement was ≥ 1.5 W/kg and the ratio of largest to smallest SAR for the original, first and second repeated measurements is > 1.20 .
- 4) Repeated measurements are not required when the original highest measured SAR is < 0.80 W/kg

**Table 12-1
Body SAR Measurement Variability Results**

BODY VARIABILITY RESULTS														
Band	FREQUENCY		Mode	Service	Side	Configuration	Spacing	Measured SAR (1g)	1st Repeated SAR (1g)	Ratio	2nd Repeated SAR (1g)	Ratio	3rd Repeated SAR (1g)	Ratio
	MHz	Ch.						(W/kg)	(W/kg)		(W/kg)		(W/kg)	
1900	1907.60	9538	UMTS 1900	RMC	top	Tilt (Top-Back Surface)	16 mm	0.919	0.913	1.01	N/A	N/A	N/A	N/A
ANSI / IEEE C95.1 1992 - SAFETY LIMIT Spatial Peak Uncontrolled Exposure/General Population							Body 1.6 W/kg (mW/g) averaged over 1 gram							

12.2 Measurement Uncertainty

The measured SAR was < 1.5 W/kg for all frequency bands. Therefore, per KDB Publication 865664 D01v01, the extended measurement uncertainty analysis per IEEE 1528-2003 was not required.

FCC ID: ACJ9TGWW13B	 PCTEST ENGINEERING LABORATORY, INC.	SAR EVALUATION REPORT		Reviewed by: Quality Manager
Document S/N: OY1412152300.ACJ	Test Dates: 12/15/14 - 01/08/15	DUT Type: Wireless Module		Page 86 of 91



13

EQUIPMENT LIST

Manufacturer	Model	Description	Cal Date	Cal Interval	Cal Due	Serial Number
Agilent	E8257D	(250kHz-20GHz) Signal Generator	4/15/2014	Annual	4/15/2015	MY45470194
Agilent	8753E	(30kHz-6GHz) Network Analyzer	12/30/2014	Annual	12/30/2015	JP38020182
Agilent	8648D	(9kHz-4GHz) Signal Generator	4/15/2014	Annual	4/15/2015	3629U00687
Agilent	E4438C	ESG Vector Signal Generator	4/25/2014	Annual	4/25/2015	MY42082385
Agilent	E4438C	ESG Vector Signal Generator	3/31/2014	Annual	3/31/2015	MY42082659
Agilent	N5182A	MXG Vector Signal Generator	4/15/2014	Annual	4/15/2015	MY47420651
Agilent	N5182A	MXG Vector Signal Generator	4/15/2014	Annual	4/15/2015	MY47420800
Agilent	E5515C	Wireless Communications Test Set	6/26/2013	Biennial	6/26/2015	GB41450275
Agilent	E5515C	Wireless Communications Test Set	3/28/2014	Annual	3/28/2015	GB42230325
Amplifier Research	1551G6	Amplifier	CBT	N/A	CBT	433971
Amplifier Research	1551G6	Amplifier	CBT	N/A	CBT	433972
Anritsu	ML2469A	Power Meter	3/14/2014	Annual	3/14/2015	1306009
Anritsu	MT8820C	Radio Communication Analyzer	9/19/2014	Annual	9/19/2015	6201144418
Anritsu	MT8820C	Radio Communication Analyzer	5/6/2014	Annual	5/6/2015	6201144419
Anritsu	MT8820C	Radio Communication Analyzer	8/28/2014	Annual	8/28/2015	6201240328
Anritsu	MA24106A	USB Power Sensor	5/14/2014	Annual	5/14/2015	1231535
Anritsu	MA24106A	USB Power Sensor	5/14/2014	Annual	5/14/2015	1231538
Anritsu	MA24106A	USB Power Sensor	5/15/2014	Annual	5/15/2015	1244512
Anritsu	MA24106A	USB Power Sensor	5/14/2014	Annual	5/14/2015	1244515
COMTech	AR85729-5	Solid State Amplifier	CBT	N/A	CBT	M155A00-009
COMTECH	AR85729-5/5759B	Solid State Amplifier	CBT	N/A	CBT	M3W1A00-1002
Control Company	4052	Long Stem Thermometer	9/27/2013	Biennial	9/27/2015	130567447
Control Company	36934-158	Wall-Mounted Thermometer	4/29/2014	Biennial	4/29/2016	122014488
Fisher Scientific	15-077-960	Digital Thermometer	12/4/2013	Biennial	12/4/2015	130764551
Fisher Scientific	S407993	Long Stem Thermometer	11/4/2013	Biennial	11/4/2015	130671826
Fisher Scientific	S97611	Thermometer	4/12/2013	Biennial	4/12/2015	130219303
Gigatronics	80701A	(0.05-18GHz) Power Sensor	10/30/2014	Annual	10/30/2015	1833460
Gigatronics	8651A	Universal Power Meter	10/30/2014	Annual	10/30/2015	8650319
MCL	BW-N6W5+	6dB Attenuator	CBT	N/A	CBT	1139
MiniCircuits	SLP-2400+	Low Pass Filter	CBT	N/A	CBT	R8979500903
Mini-Circuits	BW-N20W5+	DC to 18 GHz Precision Fixed 20 dB Attenuator	CBT	N/A	CBT	N/A
Mini-Circuits	NLP-1200+	Low Pass Filter DC to 1000 MHz	CBT	N/A	CBT	N/A
Mini-Circuits	BW-N20W5	Power Attenuator	CBT	N/A	CBT	1226
Mitutoyo	CD-6°CSX	Digital Caliper	5/8/2014	Biennial	5/8/2016	13264165
Narda	4014C-6	4 - 8 GHz SMA 6 dB Directional Coupler	CBT	N/A	CBT	N/A
Narda	BW-S3W2	Attenuator (3dB)	CBT	N/A	CBT	120
Narda	4772-3	Attenuator (3dB)	CBT	N/A	CBT	9406
Pasternack	PE2208-6	Bidirectional Coupler	CBT	N/A	CBT	N/A
Pasternack	PE2209-10	Bidirectional Coupler	CBT	N/A	CBT	N/A
Rohde & Schwarz	CMU200	Base Station Simulator	6/6/2014	Annual	6/6/2015	109892
Rohde & Schwarz	CMU200	Base Station Simulator	12/4/2014	Annual	12/4/2015	833855/0010
Rohde & Schwarz	CMW500	Radio Communication Tester	10/3/2014	Annual	10/3/2015	100976
Rohde & Schwarz	CMW500	Radio Communication Tester	4/17/2014	Annual	4/17/2015	101699
Rohde & Schwarz	CMW500	Radio Communication Tester	4/17/2014	Annual	4/17/2015	102060
Rohde & Schwarz	CMW500	Radio Communication Tester	10/4/2013	Biennial	10/4/2015	103962
Seekonk	NC-100	Torque Wrench	3/18/2014	Biennial	3/18/2016	22313
Seekonk	NC-100	Torque Wrench	3/18/2014	Biennial	3/18/2016	N/A
SPEAG	D750V3	750 MHz Dipole	3/17/2014	Annual	3/17/2015	1054
SPEAG	D835V2	835 MHz SAR Dipole	4/7/2014	Annual	4/7/2015	4d119
SPEAG	D835V2	835 MHz SAR Dipole	7/24/2014	Annual	7/24/2015	4d133
SPEAG	D1765V2	1765 MHz SAR Dipole	5/7/2014	Annual	5/7/2015	1008
SPEAG	D1900V2	1900 MHz SAR Dipole	4/9/2014	Annual	4/9/2015	5d141
SPEAG	DAE4	Dasy Data Acquisition Electronics	2/26/2014	Annual	2/26/2015	665
SPEAG	DAE4	Dasy Data Acquisition Electronics	8/12/2014	Annual	8/12/2015	1322
SPEAG	DAE4	Dasy Data Acquisition Electronics	3/17/2014	Annual	3/17/2015	1334
SPEAG	DAE4	Dasy Data Acquisition Electronics	9/18/2014	Annual	9/18/2015	1364
SPEAG	DAK-3.5	Dielectric Assessment Kit	5/6/2014	Annual	5/6/2015	1070
SPEAG	ES3DV2	SAR Probe	8/19/2014	Annual	8/19/2015	3022
SPEAG	ES3DV3	SAR Probe	3/19/2014	Annual	3/19/2015	3209
SPEAG	ES3DV3	SAR Probe	2/25/2014	Annual	2/25/2015	3258
SPEAG	ES3DV3	SAR Probe	9/24/2014	Annual	9/24/2015	3288
SPEAG	MDA4LAP	Laptop Holder	N/A	N/A	N/A	001 CD
VWR	36934-158	Wall-Mounted Thermometer	8/8/2013	Biennial	8/8/2015	130477877

Note:



1. CBT (Calibrated Before Testing). Prior to testing, the measurement paths containing a cable, amplifier, attenuator, coupler or filter were connected to a calibrated source (i.e. a signal generator) to determine the losses of the measurement path. The power meter offset was then adjusted to compensate for the measurement system losses. This level offset is stored within the power meter before measurements are made. This calibration verification procedure applies to the system verification and output power measurements. The calibrated reading is then taken directly from the power meter after compensation of the losses for all final power measurements.
2. All equipment was used within its calibration period.

FCC ID: ACJ9TGWW13B		SAR EVALUATION REPORT		Reviewed by: Quality Manager
Document S/N: OY1412152300.ACJ	Test Dates: 12/15/14 - 01/08/15	DUT Type: Wireless Module	Page 87 of 91	

14 MEASUREMENT UNCERTAINTIES

a	b	c	d	e= f(d,k)	f	g	h = c x f/e	i = c x g/e	k	
Uncertainty Component	IEEE 1528 Sec.	Tol. (± %)	Prob. Dist.	Div.	c _i 1gm	c _i 10 gms	1gm u _i (± %)	10gms u _i (± %)	v _i	
Measurement System										
Probe Calibration	E.2.1	6.0	N	1	1.0	1.0	6.0	6.0	∞	
Axial Isotropy	E.2.2	0.25	N	1	0.7	0.7	0.2	0.2	∞	
Hemishperical Isotropy	E.2.2	1.3	N	1	1.0	1.0	1.3	1.3	∞	
Boundary Effect	E.2.3	0.4	N	1	1.0	1.0	0.4	0.4	∞	
Linearity	E.2.4	0.3	N	1	1.0	1.0	0.3	0.3	∞	
System Detection Limits	E.2.5	5.1	N	1	1.0	1.0	5.1	5.1	∞	
Readout Electronics	E.2.6	1.0	N	1	1.0	1.0	1.0	1.0	∞	
Response Time	E.2.7	0.8	R	1.73	1.0	1.0	0.5	0.5	∞	
Integration Time	E.2.8	2.6	R	1.73	1.0	1.0	1.5	1.5	∞	
RF Ambient Conditions	E.6.1	3.0	R	1.73	1.0	1.0	1.7	1.7	∞	
Probe Positioner Mechanical Tolerance	E.6.2	0.4	R	1.73	1.0	1.0	0.2	0.2	∞	
Probe Positioning w/ respect to Phantom	E.6.3	2.9	R	1.73	1.0	1.0	1.7	1.7	∞	
Extrapolation, Interpolation & Integration algorithms for Max. SAR Evaluation	E.5	1.0	R	1.73	1.0	1.0	0.6	0.6	∞	
Test Sample Related										
Test Sample Positioning	E.4.2	6.0	N	1	1.0	1.0	6.0	6.0	287	
Device Holder Uncertainty	E.4.1	3.32	R	1.73	1.0	1.0	1.9	1.9	∞	
Output Power Variation - SAR drift measurement	6.6.2	5.0	R	1.73	1.0	1.0	2.9	2.9	∞	
Phantom & Tissue Parameters										
Phantom Uncertainty (Shape & Thickness tolerances)	E.3.1	4.0	R	1.73	1.0	1.0	2.3	2.3	∞	
Liquid Conductivity - deviation from target values	E.3.2	5.0	R	1.73	0.64	0.43	1.8	1.2	∞	
Liquid Conductivity - measurement uncertainty	E.3.3	3.8	N	1	0.64	0.43	2.4	1.6	6	
Liquid Permittivity - deviation from target values	E.3.2	5.0	R	1.73	0.60	0.49	1.7	1.4	∞	
Liquid Permittivity - measurement uncertainty	E.3.3	4.5	N	1	0.60	0.49	2.7	2.2	6	
Combined Standard Uncertainty (k=1)							RSS	12.1	11.7	299
Expanded Uncertainty (95% CONFIDENCE LEVEL)							k=2	24.2	23.5	

The above measurement uncertainties are according to IEEE Std. 1528-2003



FCC ID: ACJ9TGWW13B		SAR EVALUATION REPORT		Reviewed by: Quality Manager
Document S/N: OY1412152300.ACJ	Test Dates: 12/15/14 - 01/08/15	DUT Type: Wireless Module	Page 88 of 91	

15 CONCLUSION

15.1 Measurement Conclusion



The SAR evaluation indicates that the EUT complies with the RF radiation exposure limits of the FCC and Industry Canada, with respect to all parameters subject to this test. These measurements were taken to simulate the RF effects of RF exposure under worst-case conditions. Precise laboratory measures were taken to assure repeatability of the tests. The results and statements relate only to the item(s) tested.

Please note that the absorption and distribution of electromagnetic energy in the body are very complex phenomena that depend on the mass, shape, and size of the body, the orientation of the body with respect to the field vectors, and the electrical properties of both the body and the environment. Other variables that may play a substantial role in possible biological effects are those that characterize the environment (e.g. ambient temperature, air velocity, relative humidity, and body insulation) and those that characterize the individual (e.g. age, gender, activity level, debilitation, or disease). Because various factors may interact with one another to vary the specific biological outcome of an exposure to electromagnetic fields, any protection guide should consider maximal amplification of biological effects as a result of field-body interactions, environmental conditions, and physiological variables. [3]



FCC ID: ACJ9TGWW13B	 PCTEST ENGINEERING LABORATORY, INC.	SAR EVALUATION REPORT		Reviewed by: Quality Manager
Document S/N: 0Y1412152300.ACJ	Test Dates: 12/15/14 - 01/08/15	DUT Type: Wireless Module		Page 89 of 91

16 REFERENCES

- [1] Federal Communications Commission, ET Docket 93-62, Guidelines for Evaluating the Environmental Effects of Radiofrequency Radiation, Aug. 1996.
- [2] ANSI/IEEE C95.1-2005, American National Standard safety levels with respect to human exposure to radio frequency electromagnetic fields, 3kHz to 300GHz, New York: IEEE, 2006.
- [3] ANSI/IEEE C95.1-1992, American National Standard safety levels with respect to human exposure to radio frequency electromagnetic fields, 3kHz to 300GHz, New York: IEEE, Sept. 1992.
- [4] ANSI/IEEE C95.3-2002, IEEE Recommended Practice for the Measurement of Potentially Hazardous Electromagnetic Fields - RF and Microwave, New York: IEEE, December 2002.
- [5] IEEE Standards Coordinating Committee 39 –Standards Coordinating Committee 34 – IEEE Std. 1528-2003, Recommended Practice for Determining the Peak Spatial-Average Specific Absorption Rate (SAR) in the Human Head Due to Wireless Communications Devices: Measurement Techniques.
- [6] NCRP, National Council on Radiation Protection and Measurements, Biological Effects and Exposure Criteria for RadioFrequency Electromagnetic Fields, NCRP Report No. 86, 1986. Reprinted Feb. 1995.
- [7] T. Schmid, O. Egger, N. Kuster, Automated E-field scanning system for dosimetric assessments, IEEE Transaction on Microwave Theory and Techniques, vol. 44, Jan. 1996, pp. 105-113.
- [8] K. Pokovic, T. Schmid, N. Kuster, Robust setup for precise calibration of E-field probes in tissue simulating liquids at mobile communications frequencies, ICECOM97, Oct. 1997, pp. -124.
- [9] K. Pokovic, T. Schmid, and N. Kuster, E-field Probe with improved isotropy in brain simulating liquids, Proceedings of the ELMAR, Zadar, Croatia, June 23-25, 1996, pp. 172-175.
- [10] Schmid & Partner Engineering AG, Application Note: Data Storage and Evaluation, June 1998, p2.
- [11] V. Hombach, K. Meier, M. Burkhardt, E. Kuhn, N. Kuster, The Dependence of EM Energy Absorption upon Human Modeling at 900 MHz, IEEE Transaction on Microwave Theory and Techniques, vol. 44 no. 10, Oct. 1996, pp. 1865-1873.
- [12] N. Kuster and Q. Balzano, Energy absorption mechanism by biological bodies in the near field of dipole antennas above 300MHz, IEEE Transaction on Vehicular Technology, vol. 41, no. 1, Feb. 1992, pp. 17-23.
- [13] G. Hartsgrove, A. Kraszewski, A. Surowiec, Simulated Biological Materials for Electromagnetic Radiation Absorption Studies, University of Ottawa, Bioelectromagnetics, Canada: 1987, pp. 29-36.
- [14] Q. Balzano, O. Garay, T. Manning Jr., Electromagnetic Energy Exposure of Simulated Users of Portable Cellular Telephones, IEEE Transactions on Vehicular Technology, vol. 44, no.3, Aug. 1995.
- [15] W. Gander, Computermathematik, Birkhaeuser, Basel, 1992.
- [16] W.H. Press, S.A. Teukolsky, W.T. Vetterling, and B.P. Flannery, Numerical Recipes in C, The Art of Scientific Computing, Second edition, Cambridge University Press, 1992.
- [17] N. Kuster, R. Kastle, T. Schmid, Dosimetric evaluation of mobile communications equipment with known precision, IEEE Transaction on Communications, vol. E80-B, no. 5, May 1997, pp. 645-652.

FCC ID: ACJ9TGWW13B	 PCTEST ENGINEERING LABORATORY, INC.	SAR EVALUATION REPORT		Reviewed by: Quality Manager
Document S/N: 0Y1412152300.ACJ	Test Dates: 12/15/14 - 01/08/15	DUT Type: Wireless Module	Page 90 of 91	

- [18] CENELEC CLC/SC111B, European Prestandard (prENV 50166-2), Human Exposure to Electromagnetic Fields High-frequency: 10kHz-300GHz, Jan. 1995.
- [19] Prof. Dr. Niels Kuster, ETH, Eidgenössische Technische Hochschule Zürich, Dosimetric Evaluation of the Cellular Phone.
- [20] IEC 62209-1, Human exposure to radio frequency fields from hand-held and body-mounted wireless communication devices - Human models, instrumentation, and procedures - Part 1: Procedure to determine the specific absorption rate (SAR) for hand-held devices used in close proximity to the ear (frequency range of 300 MHz to 3 GHz), Feb. 2005.
- [21] Industry Canada RSS-102 Radio Frequency Exposure Compliance of Radiocommunication Apparatus (All Frequency Bands) Issue 4, March 2010.
- [22] Health Canada Safety Code 6 Limits of Human Exposure to Radio Frequency Electromagnetic Fields in the Frequency Range from 3 kHz – 300 GHz, 2009
- [23] FCC SAR Test Procedures for 2G-3G Devices, Mobile Hotspot and UMPC Devices KDB Publications 941225, D01-D07
- [24] SAR Measurement procedures for IEEE 802.11a/b/g KDB Publication 248227 D01v01r02
- [25] FCC SAR Considerations for Handsets with Multiple Transmitters and Antennas, KDB Publications 648474 D02-D04
- [26] FCC SAR Evaluation Considerations for Laptop, Notebook, Netbook and Tablet Computers, FCC KDB Publication 616217 D04
- [27] FCC SAR Measurement and Reporting Requirements for 100MHz – 6 GHz, KDB Publications 865664 D01-D02
- [28] FCC General RF Exposure Guidance and SAR Procedures for Dongles, KDB Publication 447498, D01-D02
- [29] Anexo à Resolução No. 533, de 10 de Setembro de 2009.
- [30] IEC 62209-2, Human exposure to radio frequency fields from hand-held and body-mounted wireless communication devices - Human models, instrumentation, and procedures - Part 2: Procedure to determine the specific absorption rate (SAR) for wireless communication devices used in close proximity to the human body (frequency range of 30 MHz to 6 GHz), Mar. 2010.

FCC ID: ACJ9TGWW13B		SAR EVALUATION REPORT		Reviewed by: Quality Manager
Document S/N: 0Y1412152300.ACJ	Test Dates: 12/15/14 - 01/08/15	DUT Type: Wireless Module		Page 91 of 91

APPENDIX A: SAR TEST DATA

PCTEST ENGINEERING LABORATORY, INC.

DUT: ACJ9TGWW13B; Type: Y kggu'0 qf wg; Serial: SAR-4

Communication System: UID 0, GSM GPRS; 2 Tx slots; Frequency: 824.2 MHz; Duty Cycle: 1:4.15

Medium: 835 Body, Medium parameters used (interpolated):

$f = 824.2 \text{ MHz}$; $\sigma = 0.99 \text{ S/m}$; $\epsilon_r = 55.475$; $\rho = 1000 \text{ kg/m}^3$

Phantom section: Flat Section; Space: 0.3 cm

Test Date: 12-20-2014; Ambient Temp: 21.1°C; Tissue Temp: 21.1°C

Probe: ES3DV3 - SN3288; ConvF(6.32, 6.32, 6.32); Calibrated: 9/24/2014;

Sensor-Surface: 3mm (Mechanical Surface Detection)

Electronics: DAE4 Sn1364; Calibrated: 9/18/2014

Phantom: ELI v5.0; Type: QDOVA001BB; Serial: 1229

Measurement SW: DASYS2, Version 52.8 (8); SEMCAD X Version 14.6.10 (7331)

Mode: GPRS 850, Body SAR, Right Edge, Tilt (Right-Back Surface), Low.ch, 2 Tx Slots

Area Scan (15x23x1): Measurement grid: dx=5mm, dy=15mm

Zoom Scan (5x5x7)/Cube 0: Measurement grid: dx=8mm, dy=8mm, dz=5mm

Reference Value = 27.72 V/m; Power Drift = 0.01 dB

Peak SAR (extrapolated) = 1.15 W/kg

SAR(1 g) = 0.670 W/kg

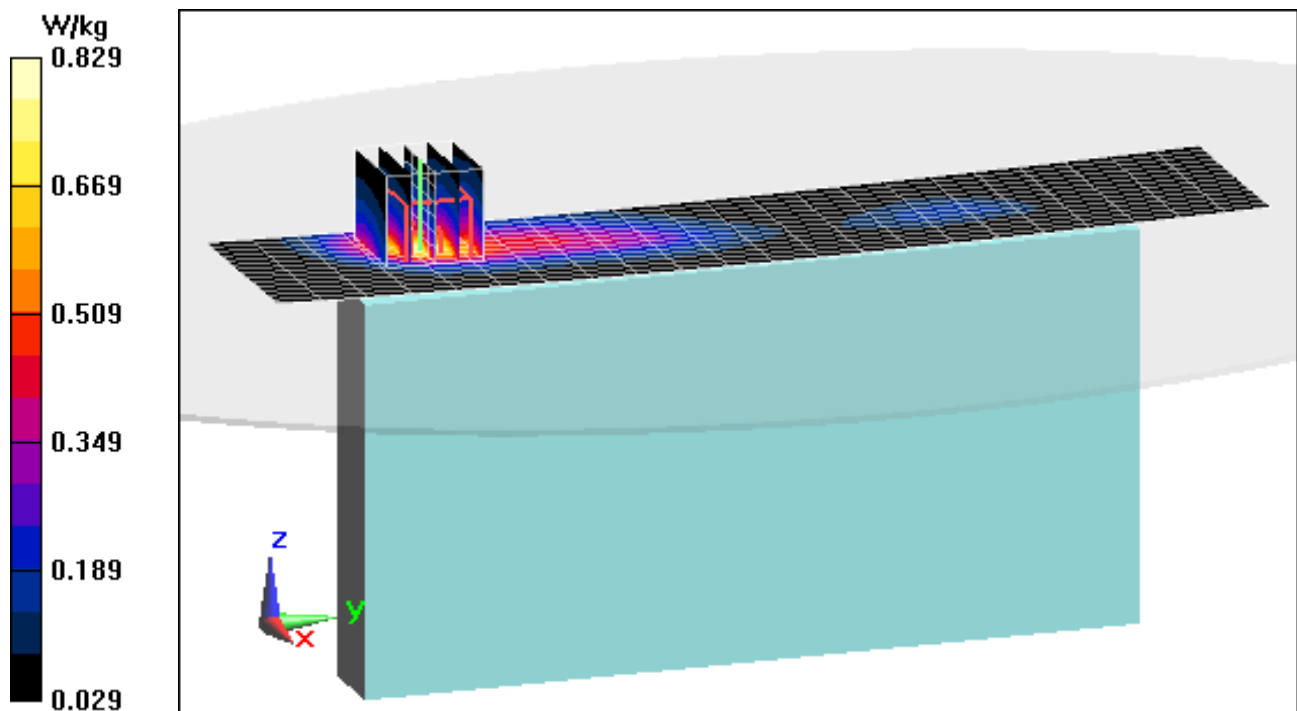

PCTEST ENGINEERING LABORATORY, INC.

DUT: ACJ9TGWW13B; Type: Y kggu'0 qf wg; Serial: SAR-3

Communication System: UID 0, GSM GPRS; 2 Tx slots; Frequency: 1880 MHz; Duty Cycle: 1:4.15

Medium: 1900 Body, Medium parameters used:

$f = 1880 \text{ MHz}$; $\sigma = 1.531 \text{ S/m}$; $\epsilon_r = 52.753$; $\rho = 1000 \text{ kg/m}^3$

Phantom section: Flat Section; Space: 1.6 cm

Test Date: 12-15-2014; Ambient Temp: 21.3°C; Tissue Temp: 20.0°C

Probe: ES3DV3 - SN3209; ConvF(4.68, 4.68, 4.68); Calibrated: 3/19/2014;

Sensor-Surface: 3mm (Mechanical Surface Detection)

Electronics: DAE4 Sn1334; Calibrated: 3/17/2014

Phantom: ELI Front; Type: QDOVA002AA; Serial: TP:1202

Measurement SW: DASY52, Version 52.8 (8); SEMCAD X Version 14.6.10 (7331)

Mode: GPRS 1900, Body SAR, Top Edge, Tilt (Top-Back Surface), Mid.ch, 2 Tx Slots

Area Scan (14x13x1): Measurement grid: dx=5mm, dy=15mm

Zoom Scan (5x5x7)/Cube 0: Measurement grid: dx=8mm, dy=8mm, dz=5mm

Reference Value = 21.17 V/m; Power Drift = 0.04 dB

Peak SAR (extrapolated) = 0.997 W/kg

SAR(1 g) = 0.634 W/kg

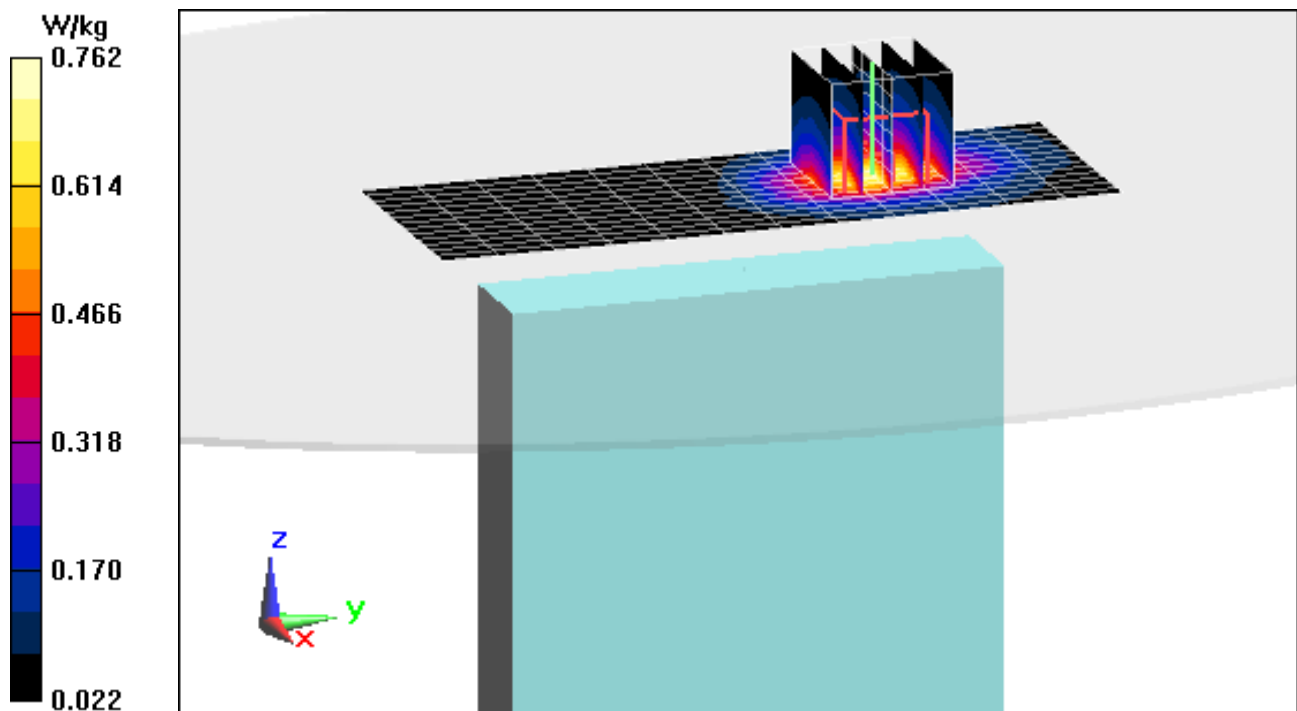

PCTEST ENGINEERING LABORATORY, INC.

DUT: ACJ9TGWW13B; Type: Y kggu'0 qf wg; Serial: SAR-4

Communication System: UID 0, UMTS; Frequency: 836.6 MHz; Duty Cycle: 1:1

Medium: 835 Body, Medium parameters used (interpolated):

$f = 836.6 \text{ MHz}$; $\sigma = 1.004 \text{ S/m}$; $\epsilon_r = 53.626$; $\rho = 1000 \text{ kg/m}^3$

Phantom section: Flat Section; Space: 0.0 cm

Test Date: 12-16-2014; Ambient Temp: 23.3°C; Tissue Temp: 22.0°C

Probe: ES3DV3 - SN3288; ConvF(6.32, 6.32, 6.32); Calibrated: 9/24/2014;

Sensor-Surface: 3mm (Mechanical Surface Detection)

Electronics: DAE4 Sn1364; Calibrated: 9/18/2014

Phantom: ELI v5.0; Type: QDOVA001BB; Serial: 1229

Measurement SW: DASY52, Version 52.8 (8); SEMCAD X Version 14.6.10 (7331)

Mode: UMTS 850, Body SAR, Back Side, Perpendicular, Mid.ch

Area Scan (14x23x1): Measurement grid: dx=15mm, dy=15mm

Zoom Scan (5x5x7)/Cube 0: Measurement grid: dx=8mm, dy=8mm, dz=5mm

Reference Value = 19.68 V/m; Power Drift = 0.07 dB

Peak SAR (extrapolated) = 0.712 W/kg

SAR(1 g) = 0.371 W/kg

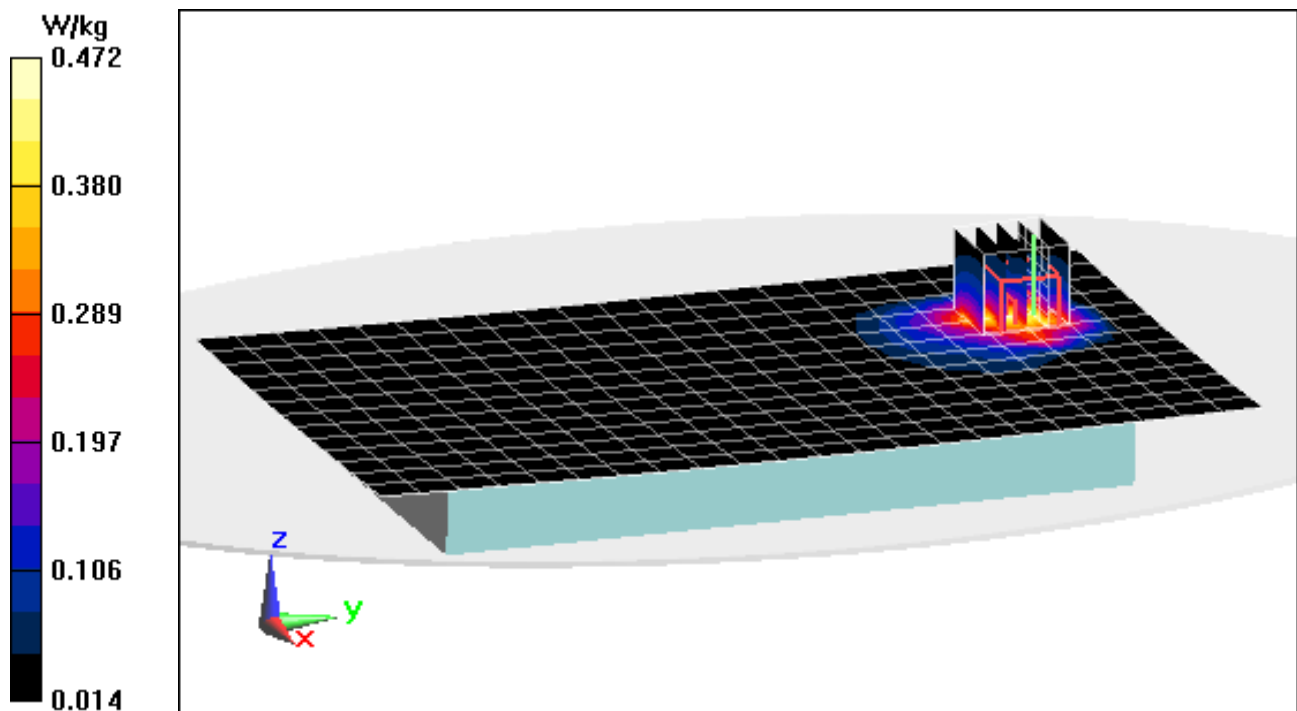

PCTEST ENGINEERING LABORATORY, INC.

DUT: ACJ9TGWW13B; Type: Y kggu'0 qf wg; Serial: SAR-3

Communication System: UID 0, UMTS; Frequency: 1732.4 MHz; Duty Cycle: 1:1

Medium: 1750 Body, Medium parameters used (interpolated):

$f = 1732.4$ MHz; $\sigma = 1.523$ S/m; $\epsilon_r = 52.089$; $\rho = 1000$ kg/m³

Phantom section: Flat Section; Space: 1.6 cm

Test Date: 12-22-2014; Ambient Temp: 23.6°C; Tissue Temp: 21.8°C

Probe: ES3DV3 - SN3258; ConvF(4.83, 4.83, 4.83); Calibrated: 2/25/2014;

Sensor-Surface: 3mm (Mechanical Surface Detection)

Electronics: DAE4 Sn665; Calibrated: 2/26/2014

Phantom: ELI v5.0; Type: QDOVA002AA; Serial: TP-1158

Measurement SW: DASY52, Version 52.8 (8); SEMCAD X Version 14.6.10 (7331)

Mode: UMTS 1750, Body SAR, Top Edge, Tilt (Top-Back Surface), Mid.ch

Area Scan (15x14x1): Measurement grid: dx=5mm, dy=15mm

Zoom Scan (5x5x7)/Cube 0: Measurement grid: dx=8mm, dy=8mm, dz=5mm

Reference Value = 21.51 V/m; Power Drift = -0.02 dB

Peak SAR (extrapolated) = 0.954 W/kg

SAR(1 g) = 0.613 W/kg

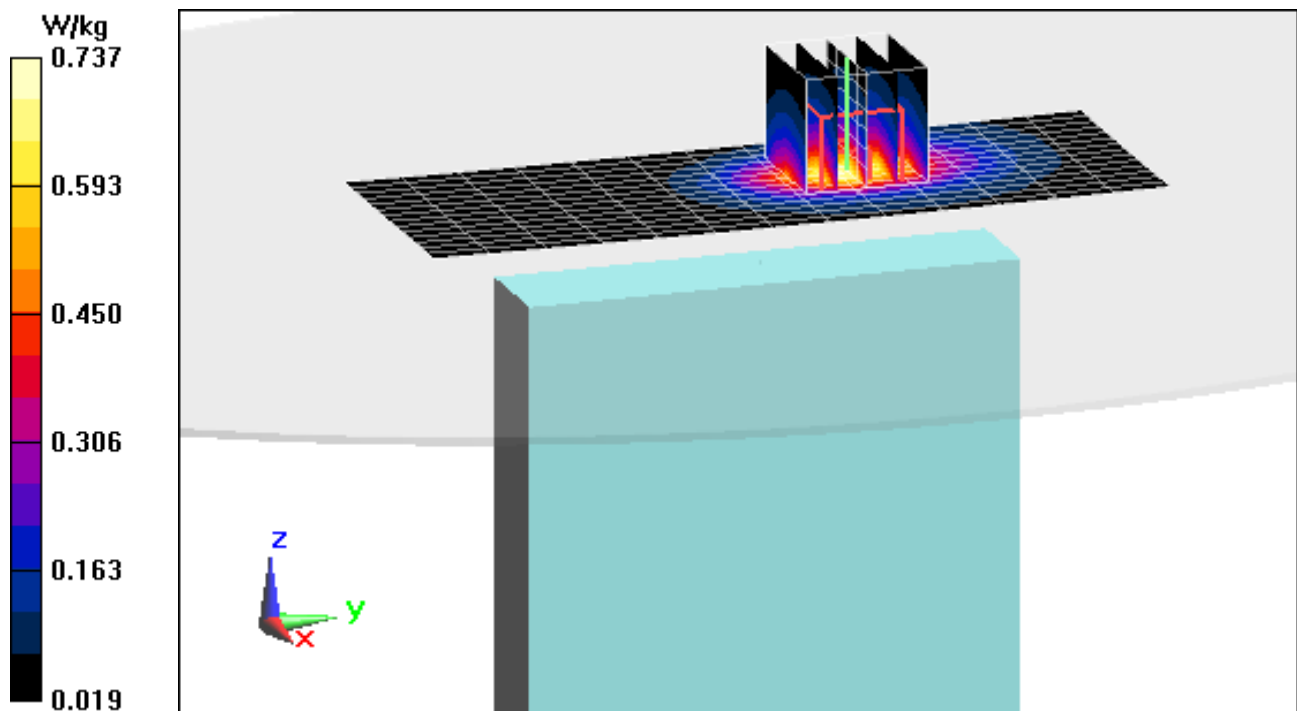

PCTEST ENGINEERING LABORATORY, INC.

DUT: ACJ9TGWW13B; Type: Y kggu'0 qf wg; Serial: SAR-3

Communication System: UID 0, UMTS; Frequency: 1907.6 MHz; Duty Cycle: 1:1

Medium: 1900 Body, Medium parameters used (interpolated):

$f = 1907.6 \text{ MHz}$; $\sigma = 1.562 \text{ S/m}$; $\epsilon_r = 52.648$; $\rho = 1000 \text{ kg/m}^3$

Phantom section: Flat Section; Space: 1.6 cm

Test Date: 12-15-2014; Ambient Temp: 21.3°C; Tissue Temp: 20.0°C

Probe: ES3DV3 - SN3209; ConvF(4.68, 4.68, 4.68); Calibrated: 3/19/2014;

Sensor-Surface: 3mm (Mechanical Surface Detection)

Electronics: DAE4 Sn1334; Calibrated: 3/17/2014

Phantom: ELI Front; Type: QDOVA002AA; Serial: TP:1202

Measurement SW: DASY52, Version 52.8 (8); SEMCAD X Version 14.6.10 (7331)

Mode: UMTS 1900, Body SAR, Top Edge, Tilt (Top-Back Surface), High.ch

Area Scan (14x11x1): Measurement grid: dx=5mm, dy=15mm

Zoom Scan (5x5x7)/Cube 0: Measurement grid: dx=8mm, dy=8mm, dz=5mm

Reference Value = 26.06 V/m; Power Drift = -0.15 dB

Peak SAR (extrapolated) = 1.49 W/kg

SAR(1 g) = 0.919 W/kg

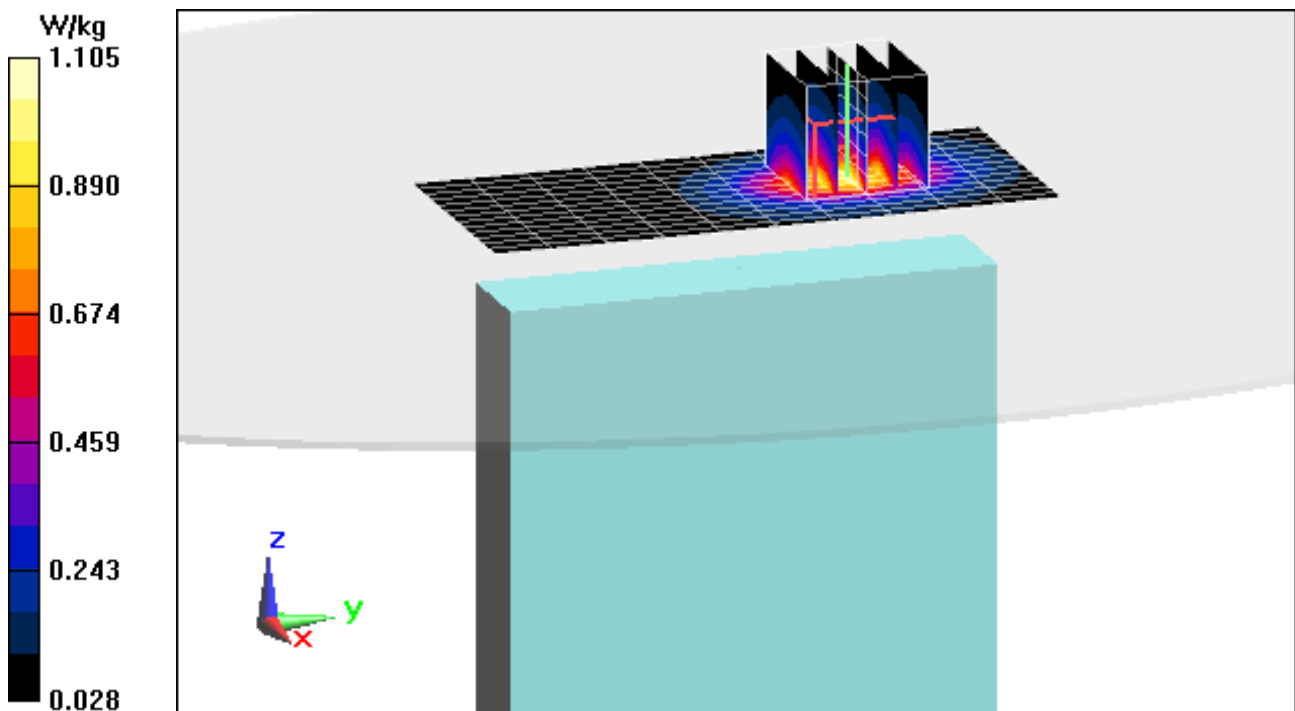

PCTEST ENGINEERING LABORATORY, INC.

DUT: ACJ9TGWW13B; Type: Y kggu'0 qf wg; Serial: SAR-3

Communication System: UID 0, CDMA; Frequency: 820.1 MHz; Duty Cycle: 1:1

Medium: 835 Body, Medium parameters used (interpolated):

$f = 820.1 \text{ MHz}$; $\sigma = 1.001 \text{ S/m}$; $\epsilon_r = 53.78$; $\rho = 1000 \text{ kg/m}^3$

Phantom section: Flat Section; Space: 0.0 cm

Test Date: 01-05-2015; Ambient Temp: 23.4°C; Tissue Temp: 22.1°C

Probe: ES3DV3 - SN3288; ConvF(6.32, 6.32, 6.32); Calibrated: 9/24/2014;

Sensor-Surface: 3mm (Mechanical Surface Detection)

Electronics: DAE4 Sn1364; Calibrated: 9/18/2014

Phantom: ELI v5.0; Type: QDOVA001BB; Serial: 1229

Measurement SW: DASY52, Version 52.8 (8); SEMCAD X Version 14.6.10 (7331)

Mode: Cell. EVDO Rev.0 BC10, Body SAR, Back Side, Perpendicular, Mid.ch

Area Scan (13x23x1): Measurement grid: dx=15mm, dy=15mm

Zoom Scan (6x6x7)/Cube 0: Measurement grid: dx=8mm, dy=8mm, dz=5mm

Reference Value = 22.04 V/m; Power Drift = -0.01 dB

Peak SAR (extrapolated) = 0.842 W/kg

SAR(1 g) = 0.477 W/kg

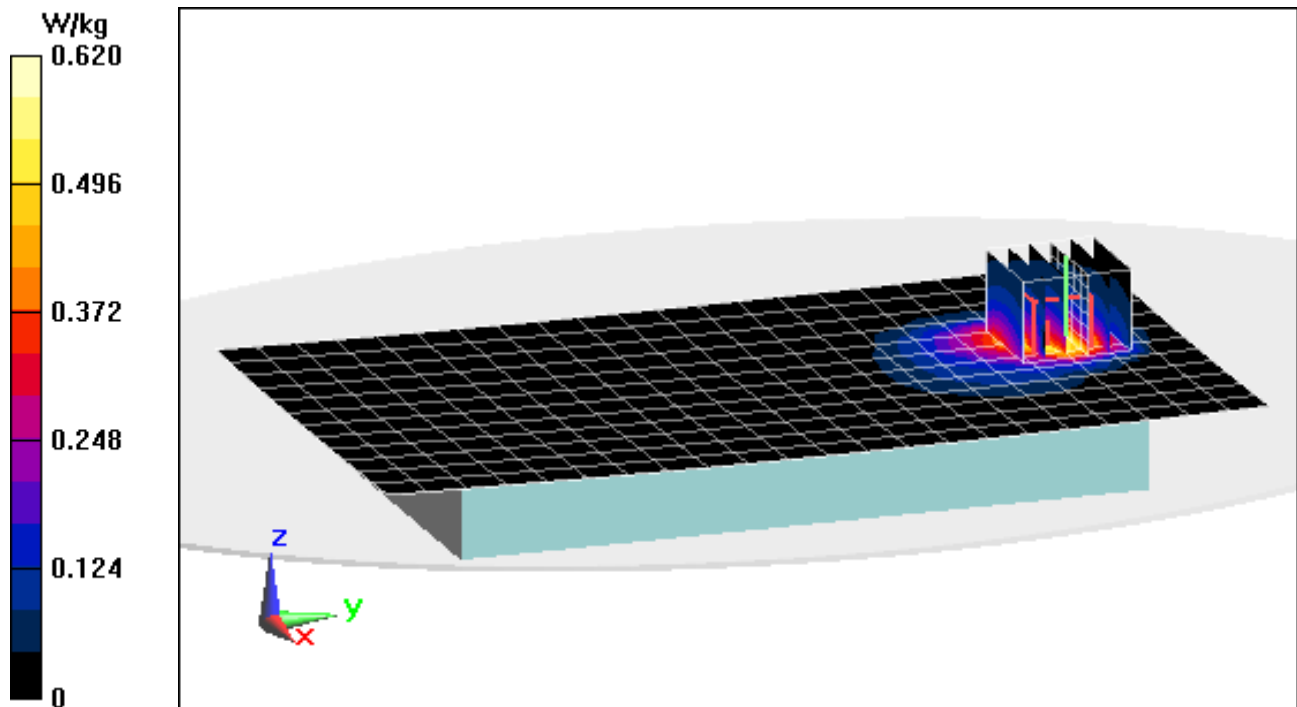

PCTEST ENGINEERING LABORATORY, INC.

DUT: ACJ9TGWW13B; Type: Wireless Module; Serial: SAR-3

Communication System: UID 0, CDMA; Frequency: 836.52 MHz; Duty Cycle: 1:1
Medium: 835 Body, Medium parameters used (interpolated):
 $f = 836.52 \text{ MHz}$; $\sigma = 1.017 \text{ S/m}$; $\epsilon_r = 53.618$; $\rho = 1000 \text{ kg/m}^3$
Phantom section: Flat Section; Space: 0.0 cm

Test Date: 01-05-2015; Ambient Temp: 23.4°C; Tissue Temp: 22.1°C

Probe: ES3DV3 - SN3288; ConvF(6.32, 6.32, 6.32); Calibrated: 9/24/2014;
Sensor-Surface: 3mm (Mechanical Surface Detection)
Electronics: DAE4 Sn1364; Calibrated: 9/18/2014
Phantom: ELI v5.0; Type: QDOVA001BB; Serial: 1229
Measurement SW: DASY52, Version 52.8 (8); SEMCAD X Version 14.6.10 (7331)

Mode: Cell. EVDO Rev.0 BC0, Body SAR, Back Side, Perpendicular, Mid.ch

Area Scan (13x23x1): Measurement grid: dx=15mm, dy=15mm

Zoom Scan (6x6x7)/Cube 0: Measurement grid: dx=8mm, dy=8mm, dz=5mm

Reference Value = 23.79 V/m; Power Drift = 0.03 dB

Peak SAR (extrapolated) = 1.07 W/kg

SAR(1 g) = 0.553 W/kg

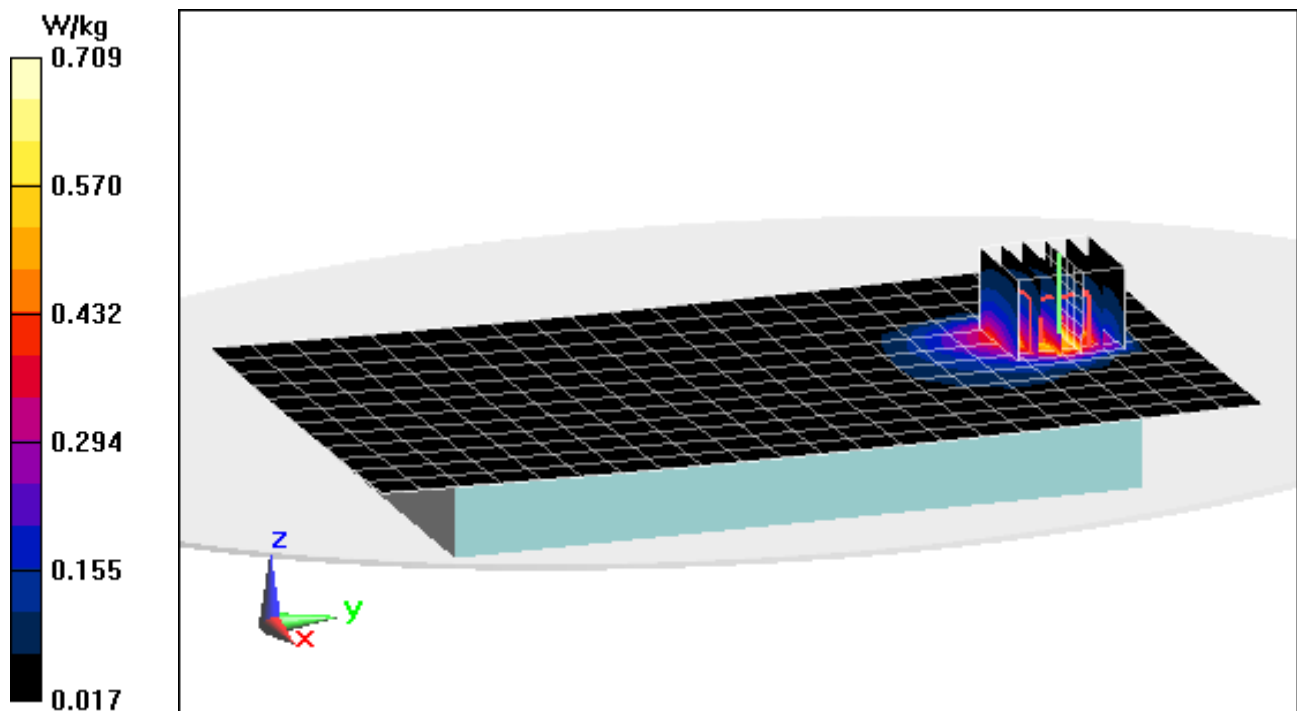

PCTEST ENGINEERING LABORATORY, INC.

DUT: ACJ9TGWW13B; Type: Wireless Module; Serial: SAR-3

Communication System: UID 0, CDMA, Frequency: 1908.75 MHz; Duty Cycle: 1:1
Medium: 1900 Body, Medium parameters used (interpolated):
 $f = 1908.75 \text{ MHz}$; $\sigma = 1.526 \text{ S/m}$; $\epsilon_r = 52.677$; $\rho = 1000 \text{ kg/m}^3$
Phantom section: Flat Section; Space: 1.6 cm

Test Date: 01-08-2015; Ambient Temp: 23.6°C; Tissue Temp: 22.5°C

Probe: ES3DV3 - SN3258; ConvF(4.61, 4.61, 4.61); Calibrated: 2/25/2014;
Sensor-Surface: 3mm (Mechanical Surface Detection)
Electronics: DAE4 Sn665; Calibrated: 2/26/2014
Phantom: ELI v5.0; Type: QDOVA002AA; Serial: TP-1158
Measurement SW: DASY52, Version 52.8 (8); SEMCAD X Version 14.6.10 (7331)

Mode: PCS EVDO Rev.0, Body SAR, Top Edge, Tilt (Top-Back Surface), High.ch

Area Scan (13x13x1): Measurement grid: dx=5mm, dy=15mm

Zoom Scan (5x6x7)/Cube 0: Measurement grid: dx=8mm, dy=8mm, dz=5mm

Reference Value = 23.58 V/m; Power Drift = 0.01 dB

Peak SAR (extrapolated) = 1.34 W/kg

SAR(1 g) = 0.834 W/kg

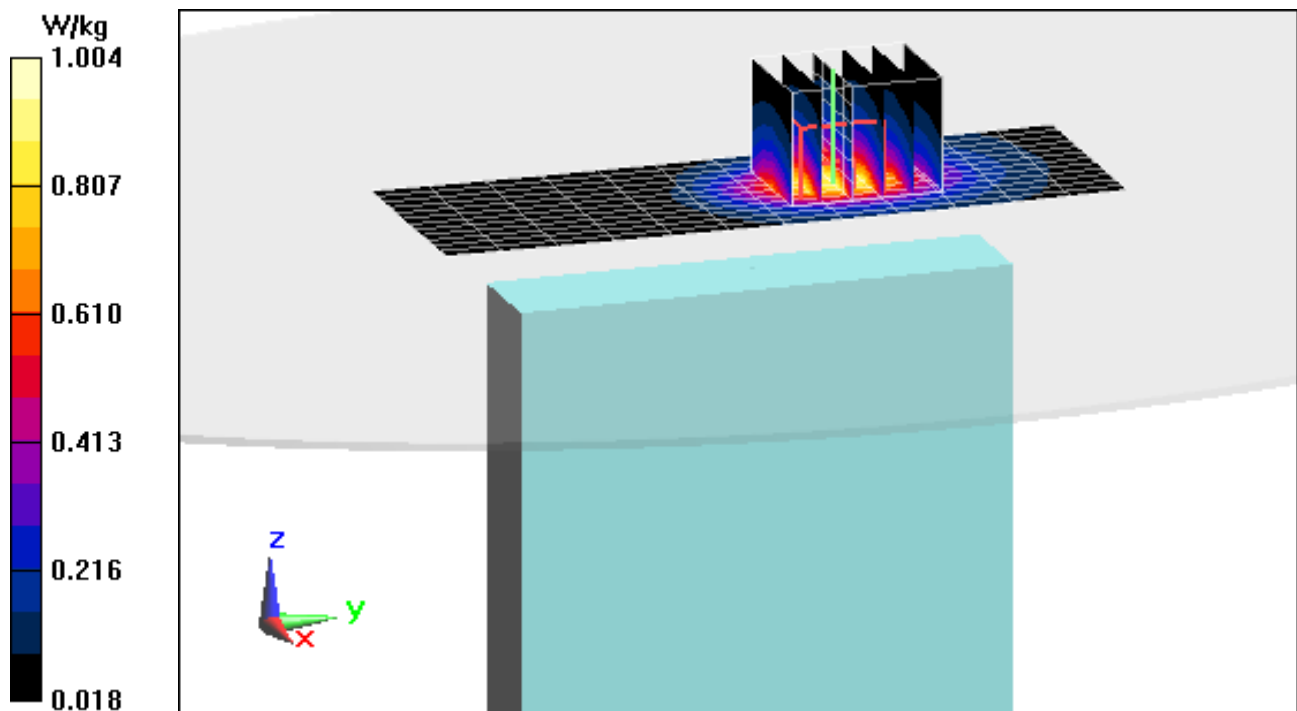

PCTEST ENGINEERING LABORATORY, INC.

DUT: ACJ9TGWW13B; Type: Wireless Module; Serial: SAR-5

Communication System: UID 0, LTE Band 17; Frequency: 710 MHz; Duty Cycle: 1:1

Medium: 750 Body, Medium parameters used:

$f = 710 \text{ MHz}$; $\sigma = 0.921 \text{ S/m}$; $\epsilon_r = 54.356$; $\rho = 1000 \text{ kg/m}^3$

Phantom section: Flat Section; Space: 0.0 cm

Test Date: 12-16-2014; Ambient Temp: 24.5°C; Tissue Temp: 22.0°C

Probe: ES3DV3 - SN3258; ConvF(6.15, 6.15, 6.15); Calibrated: 2/25/2014;

Sensor-Surface: 3mm (Mechanical Surface Detection)

Electronics: DAE4 Sn665; Calibrated: 2/26/2014

Phantom: ELI v5.0; Type: QDOVA002AA; Serial: TP-1158

Measurement SW: DASY52, Version 52.8 (8); SEMCAD X Version 14.6.10 (7331)

**Mode: LTE Band 17, Body SAR, Back Side, Perpendicular, Mid.ch,
10 MHz Bandwidth, QPSK, 25 RB, 25 RB Offset**

Area Scan (12x21x1): Measurement grid: dx=15mm, dy=15mm

Zoom Scan (6x6x7)/Cube 0: Measurement grid: dx=8mm, dy=8mm, dz=5mm

Reference Value = 18.62 V/m; Power Drift = 0.05 dB

Peak SAR (extrapolated) = 0.564 W/kg

SAR(1 g) = 0.302 W/kg

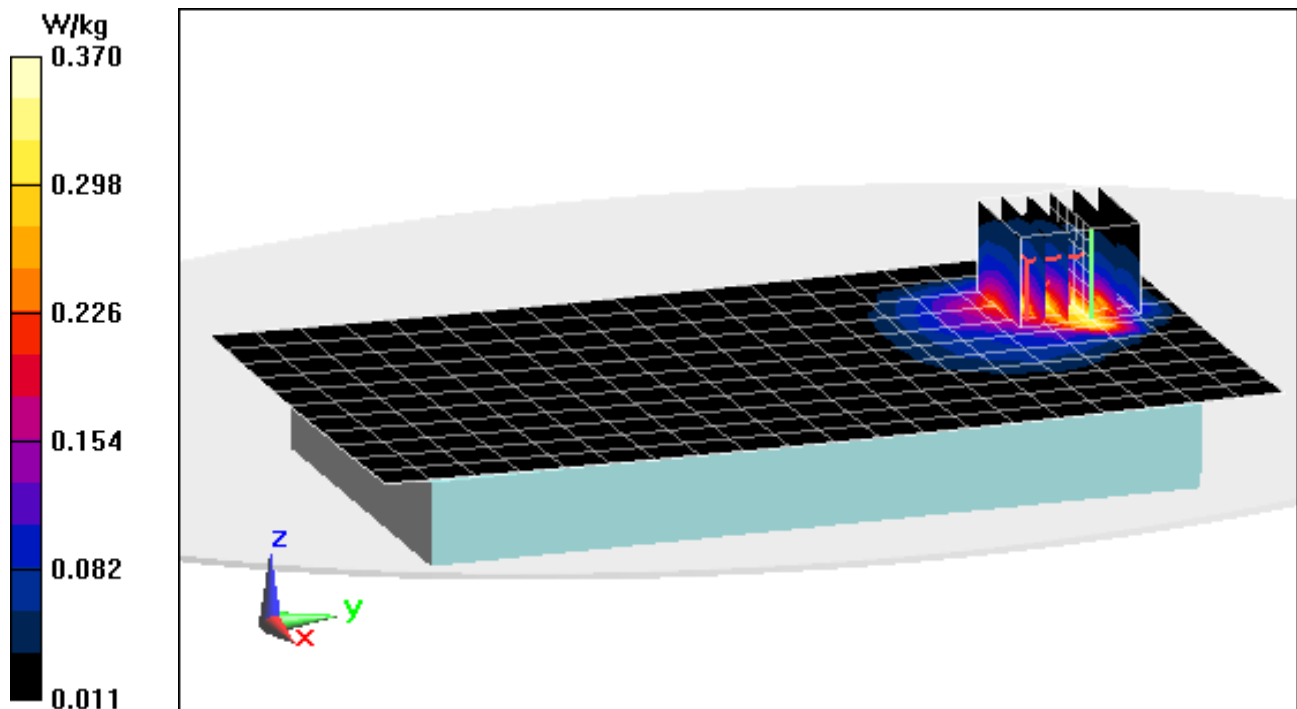

PCTEST ENGINEERING LABORATORY, INC.

DUT: ACJ9TGWW13B; Type: Wireless Module; Serial: SAR-5

Communication System: UID 0, LTE Band 13; Frequency: 782 MHz; Duty Cycle: 1:1

Medium: 750 Body, Medium parameters used (interpolated):

$f = 782 \text{ MHz}$; $\sigma = 0.989 \text{ S/m}$; $\epsilon_r = 53.574$; $\rho = 1000 \text{ kg/m}^3$

Phantom section: Flat Section; Space: 0.0 cm

Test Date: 12-16-2014; Ambient Temp: 24.5°C; Tissue Temp: 22.0°C

Probe: ES3DV3 - SN3258; ConvF(6.15, 6.15, 6.15); Calibrated: 2/25/2014;

Sensor-Surface: 3mm (Mechanical Surface Detection)

Electronics: DAE4 Sn665; Calibrated: 2/26/2014

Phantom: ELI v5.0; Type: QDOVA002AA; Serial: TP-1158

Measurement SW: DASY52, Version 52.8 (8); SEMCAD X Version 14.6.10 (7331)

**Mode: LTE Band 13, Body SAR, Back Side, Perpendicular, Mid.ch,
10 MHz Bandwidth, QPSK, 25 RB, 12 RB Offset**

Area Scan (12x21x1): Measurement grid: dx=15mm, dy=15mm

Zoom Scan (6x6x7)/Cube 0: Measurement grid: dx=8mm, dy=8mm, dz=5mm

Reference Value = 19.06 V/m; Power Drift = -0.04 dB

Peak SAR (extrapolated) = 0.618 W/kg

SAR(1 g) = 0.328 W/kg

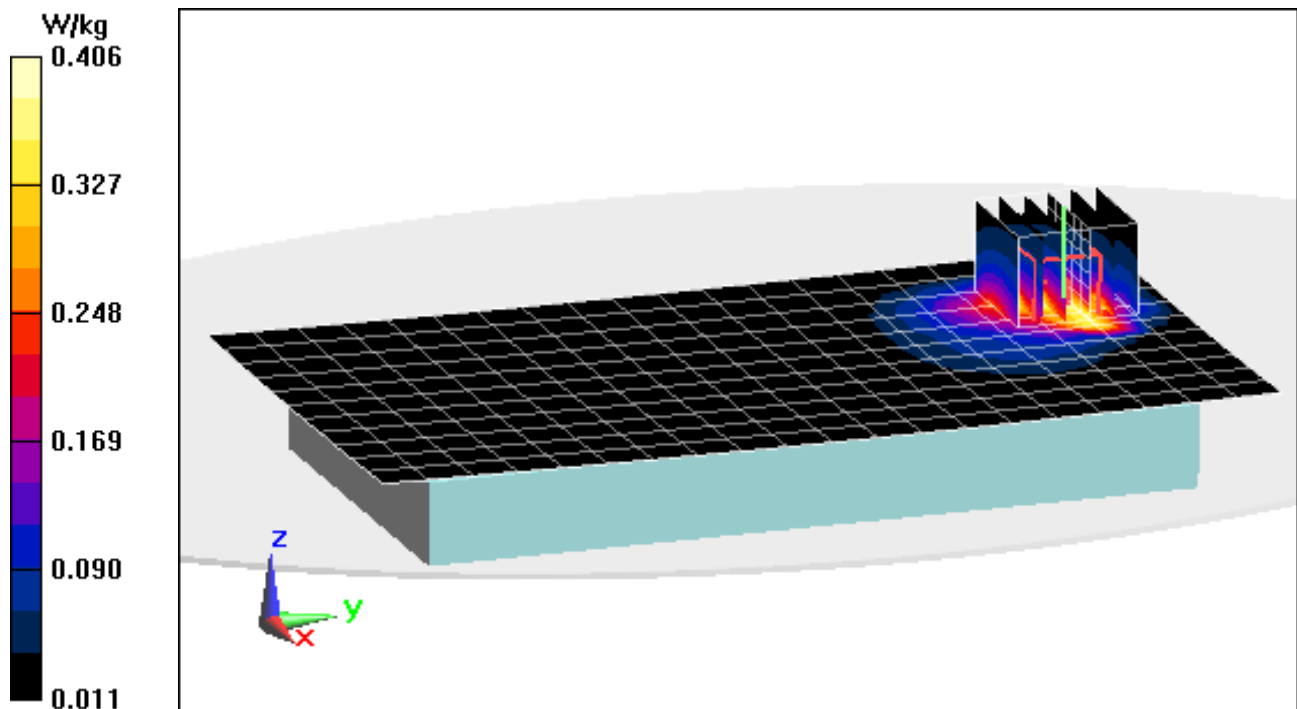

PCTEST ENGINEERING LABORATORY, INC.

DUT: ACJ9TGWW13B; Type: Wireless Module; Serial: SAR-5

Communication System: UID 0, LTE Band 5; Frequency: 836.5 MHz; Duty Cycle: 1:1

Medium: 835 Body, Medium parameters used (interpolated):

$f = 836.5 \text{ MHz}$; $\sigma = 1.004 \text{ S/m}$; $\epsilon_r = 53.627$; $\rho = 1000 \text{ kg/m}^3$

Phantom section: Flat Section; Space: 0.0 cm

Test Date: 12-16-2014; Ambient Temp: 23.3°C; Tissue Temp: 22.0°C

Probe: ES3DV3 - SN3288; ConvF(6.32, 6.32, 6.32); Calibrated: 9/24/2014;

Sensor-Surface: 3mm (Mechanical Surface Detection)

Electronics: DAE4 Sn1364; Calibrated: 9/18/2014

Phantom: ELI v5.0; Type: QDOVA001BB; Serial: 1229

Measurement SW: DASY52, Version 52.8 (8); SEMCAD X Version 14.6.10 (7331)

**Mode: LTE Band 5 (Cell.), Body SAR, Back Side, Perpendicular, Mid.ch,
10 MHz Bandwidth, QPSK, 1 RB, 25 RB Offset**

Area Scan (13x23x1): Measurement grid: dx=15mm, dy=15mm

Zoom Scan (6x6x7)/Cube 0: Measurement grid: dx=8mm, dy=8mm, dz=5mm

Reference Value = 21.28 V/m; Power Drift = -0.13 dB

Peak SAR (extrapolated) = 0.780 W/kg

SAR(1 g) = 0.396 W/kg

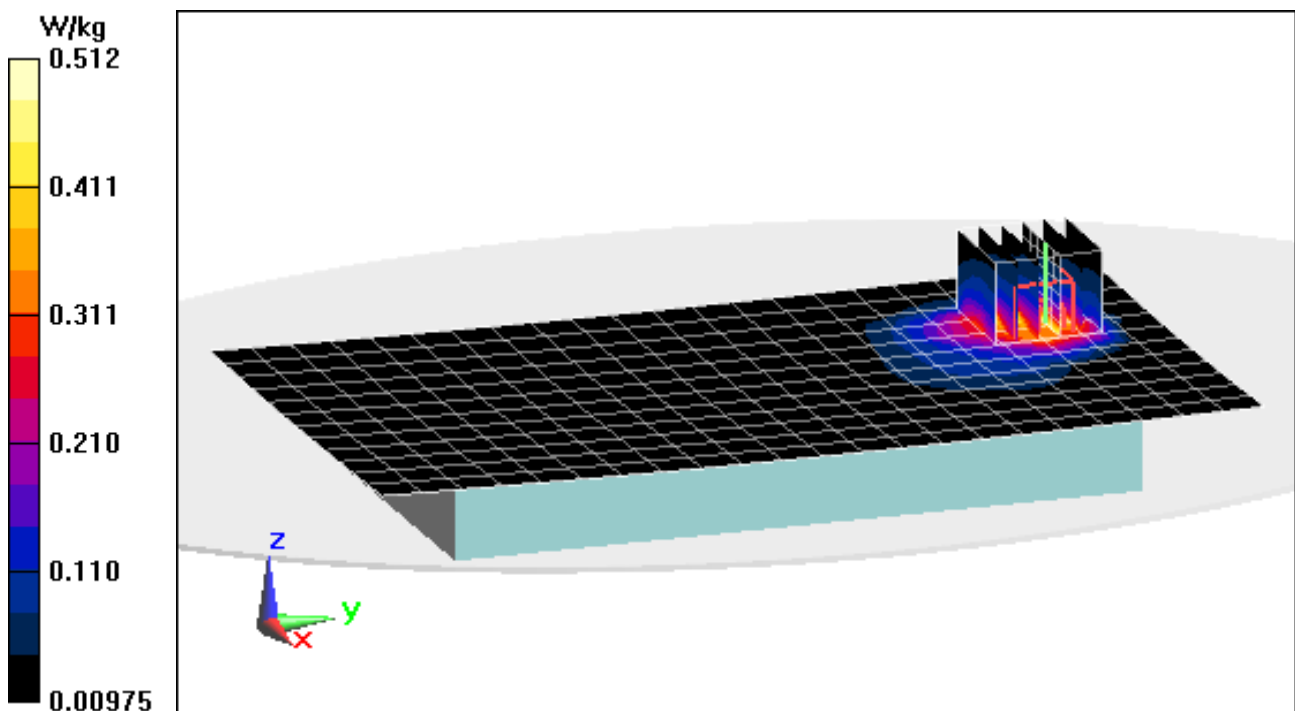

PCTEST ENGINEERING LABORATORY, INC.

DUT: ACJ9TGWW13B; Type: Wireless Module; Serial: SAR-5

Communication System: UID 0, LTE Band 4 (AWS); Frequency: 1732.5 MHz; Duty Cycle: 1:1

Medium: 1750 Body, Medium parameters used (interpolated):

$f = 1732.5 \text{ MHz}$; $\sigma = 1.449 \text{ S/m}$; $\epsilon_r = 51.485$; $\rho = 1000 \text{ kg/m}^3$

Phantom section: Flat Section; Space: 1.6 cm

Test Date: 12-17-2014; Ambient Temp: 22.0°C; Tissue Temp: 21.0°C

Probe: ES3DV2 - SN3022; ConvF(4.7, 4.7, 4.7); Calibrated: 8/19/2014;

Sensor-Surface: 3mm (Mechanical Surface Detection)

Electronics: DAE4 Sn1322; Calibrated: 8/12/2014

Phantom: ELI v5.0; Type: QDOVA001BB; Serial: 1226

Measurement SW: DASY52, Version 52.8 (8); SEMCAD X Version 14.6.10 (7331)

**Mode: LTE Band 4 (AWS), Body SAR, Top Edge, Tilt (Top-Back Surface), Mid.ch,
20 MHz Bandwidth, QPSK, 1 RB, 99 RB Offset**

Area Scan (15x14x1): Measurement grid: dx=5mm, dy=15mm

Zoom Scan (5x5x7)/Cube 0: Measurement grid: dx=8mm, dy=8mm, dz=5mm

Reference Value = 24.61 V/m; Power Drift = 0.06 dB

Peak SAR (extrapolated) = 1.25 W/kg

SAR(1 g) = 0.771 W/kg

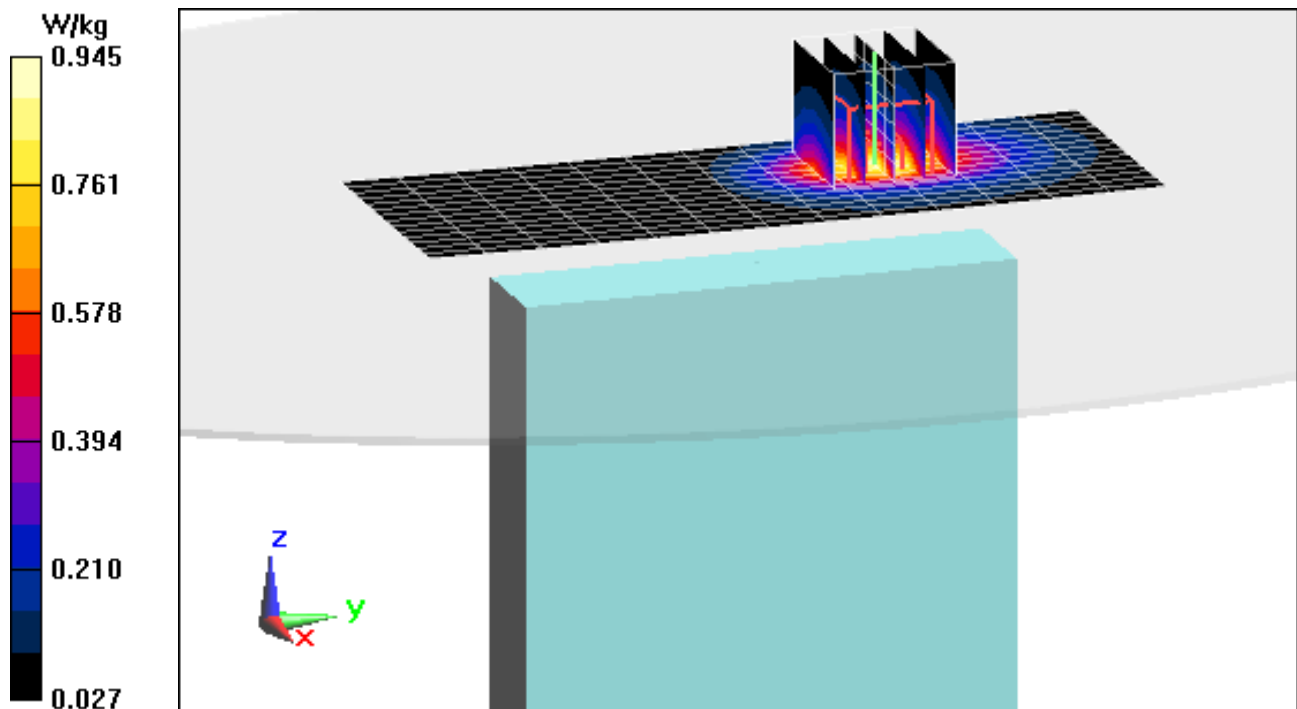

PCTEST ENGINEERING LABORATORY, INC.

DUT: ACJ9TGWW13B; Type: Wireless Module; Serial: SAR-4

Communication System: UID 0, LTE Band 25 (PCS); Frequency: 1905 MHz; Duty Cycle: 1:1

Medium: 1900 Body, Medium parameters used (interpolated):

$f = 1905 \text{ MHz}$; $\sigma = 1.583 \text{ S/m}$; $\epsilon_r = 52.248$; $\rho = 1000 \text{ kg/m}^3$

Phantom section: Flat Section; Space: 1.8 cm

Test Date: 12-19-2014; Ambient Temp: 24.5°C; Tissue Temp: 22.2°C

Probe: ES3DV3 - SN3209; ConvF(4.68, 4.68, 4.68); Calibrated: 3/19/2014;

Sensor-Surface: 3mm (Mechanical Surface Detection)

Electronics: DAE4 Sn1334; Calibrated: 3/17/2014

Phantom: ELI Front; Type: QDOVA002AA; Serial: TP:1202

Measurement SW: DASY52, Version 52.8 (8); SEMCAD X Version 14.6.10 (7331)

**Mode: LTE Band 25 (PCS), Body SAR, Back Side, Perpendicular, High.ch,
20 MHz Bandwidth, QPSK, 1 RB, 50 RB Offset**

Area Scan (13x21x1): Measurement grid: dx=15mm, dy=15mm

Zoom Scan (7x5x7)/Cube 0: Measurement grid: dx=8mm, dy=8mm, dz=5mm

Reference Value = 20.23 V/m; Power Drift = -0.12 dB

Peak SAR (extrapolated) = 1.30 W/kg

SAR(1 g) = 0.811 W/kg

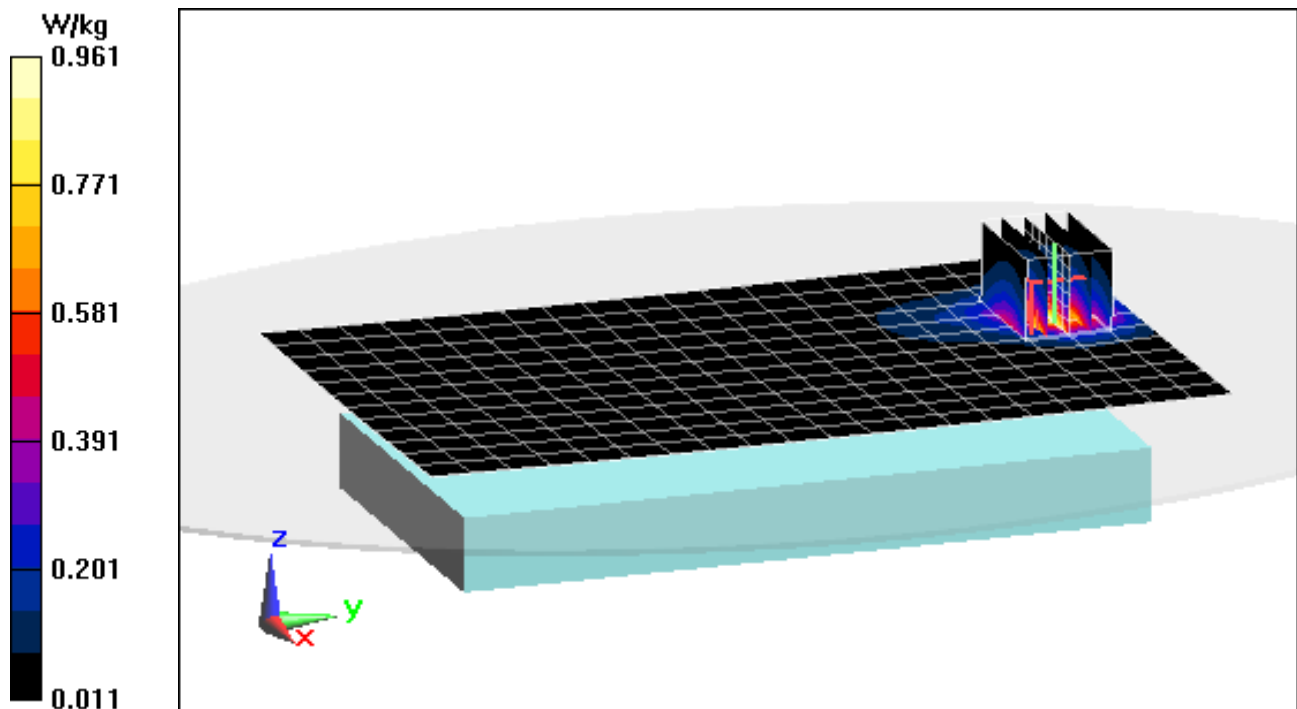

APPENDIX B: SYSTEM VERIFICATION

PCTEST ENGINEERING LABORATORY, INC.

DUT: Dipole 750 MHz; Type: D750V3; Serial: 1054

Communication System: UID 0, CW; Frequency: 750 MHz; Duty Cycle: 1:1

Medium: 750 Body, Medium parameters used (interpolated):

$f = 750 \text{ MHz}$; $\sigma = 0.958 \text{ S/m}$; $\epsilon_r = 53.996$; $\rho = 1000 \text{ kg/m}^3$

Phantom section: Flat Section; Space: 1.5 cm

Test Date: 12-16-2014; Ambient Temp: 24.5°C; Tissue Temp: 22.0°C

Probe: ES3DV3 - SN3258; ConvF(6.15, 6.15, 6.15); Calibrated: 2/25/2014;

Sensor-Surface: 3mm (Mechanical Surface Detection)

Electronics: DAE4 Sn665; Calibrated: 2/26/2014

Phantom: ELI v5.0; Type: QDOVA002AA; Serial: TP-1158

Measurement SW: DASY52, Version 52.8 (8); SEMCAD X Version 14.6.10 (7331)

750 MHz System Verification

Area Scan (7x15x1): Measurement grid: dx=15mm, dy=15mm

Zoom Scan (5x5x7)/Cube 0: Measurement grid: dx=8mm, dy=8mm, dz=5mm

Input Power = 20.0 dBm (100 mW)

Peak SAR (extrapolated) = 1.27 W/kg

SAR(1 g) = 0.871 W/kg

Deviation = 0.81%

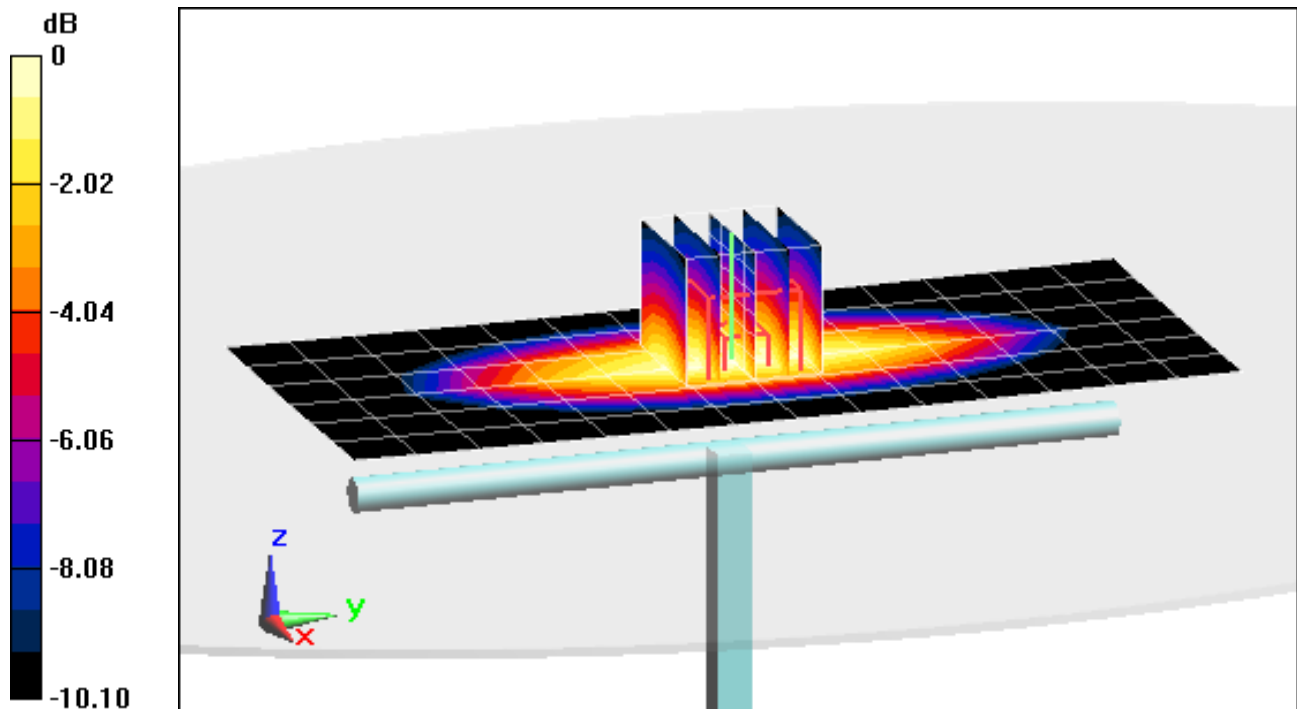

0 dB = 1.02 W/kg = 0.09 dBW/kg

PCTEST ENGINEERING LABORATORY, INC.

DUT: Dipole 835 MHz; Type: D835V2; Serial: 4d119

Communication System: UID 0, CW; Frequency: 835 MHz; Duty Cycle: 1:1

Medium: 835 Body, Medium parameters used:

$f = 835 \text{ MHz}$; $\sigma = 1.003 \text{ S/m}$; $\epsilon_r = 53.638$; $\rho = 1000 \text{ kg/m}^3$

Phantom section: Flat Section; Space: 1.5 cm

Test Date: 12-16-2014; Ambient Temp: 23.3°C; Tissue Temp: 22.0°C

Probe: ES3DV3 - SN3288; ConvF(6.32, 6.32, 6.32); Calibrated: 9/24/2014;

Sensor-Surface: 3mm (Mechanical Surface Detection)

Electronics: DAE4 Sn1364; Calibrated: 9/18/2014

Phantom: ELI v5.0; Type: QDOVA001BB; Serial: 1229

Measurement SW: DASY52, Version 52.8 (8); SEMCAD X Version 14.6.10 (7331)

835 MHz System Verification

Area Scan (7x14x1): Measurement grid: dx=15mm, dy=15mm

Zoom Scan (5x5x7)/Cube 0: Measurement grid: dx=8mm, dy=8mm, dz=5mm

Input Power = 20.0 dBm (100 mW)

Peak SAR (extrapolated) = 1.45 W/kg

SAR(1 g) = 0.984 W/kg

Deviation = 5.35%

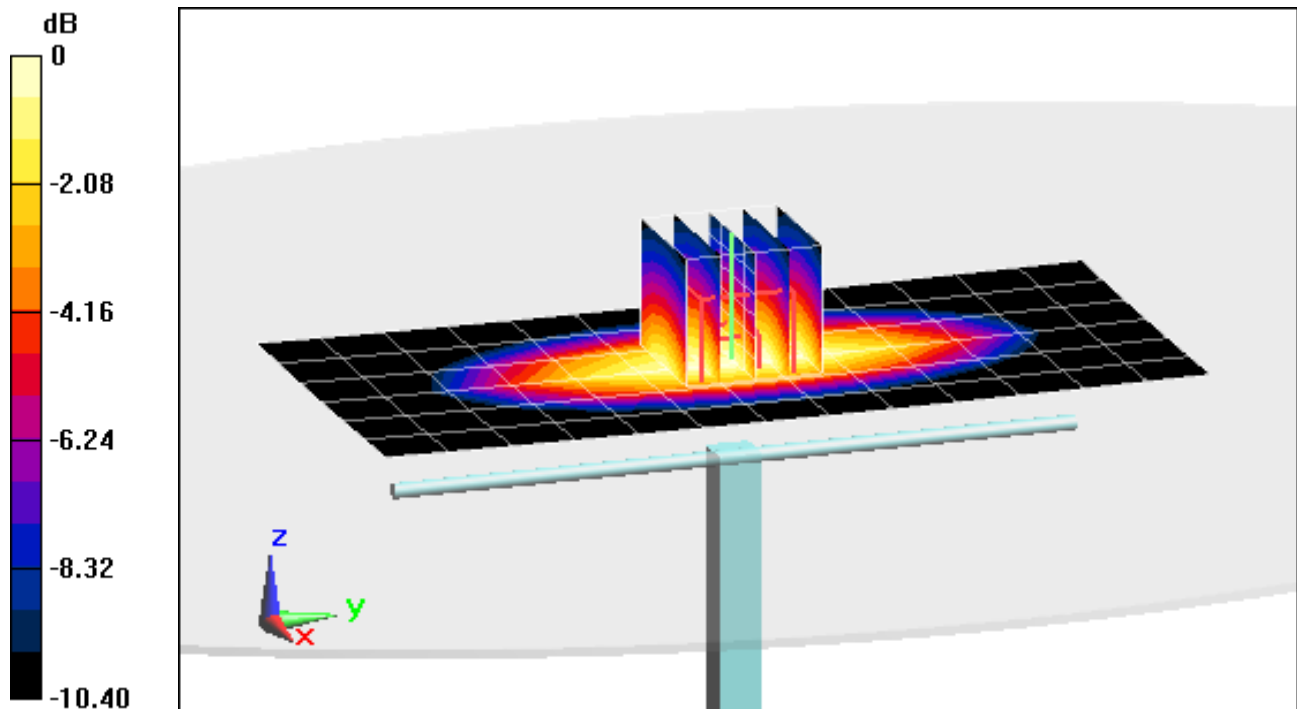

0 dB = 1.15 W/kg = 0.61 dBW/kg

PCTEST ENGINEERING LABORATORY, INC.

DUT: Dipole 835 MHz; Type: D835V2; Serial: 4d133

Communication System: UID 0, CW; Frequency: 835 MHz; Duty Cycle: 1:1

Medium: 835 Body, Medium parameters used:

$f = 835 \text{ MHz}$; $\sigma = 1 \text{ S/m}$; $\epsilon_r = 55.317$; $\rho = 1000 \text{ kg/m}^3$

Phantom section: Flat Section; Space: 1.5 cm

Test Date: 12-20-2014; Ambient Temp: 21.1°C; Tissue Temp: 21.1°C

Probe: ES3DV3 - SN3288; ConvF(6.32, 6.32, 6.32); Calibrated: 9/24/2014;

Sensor-Surface: 3mm (Mechanical Surface Detection)

Electronics: DAE4 Sn1364; Calibrated: 9/18/2014

Phantom: ELI v5.0; Type: QDOVA001BB; Serial: 1229

Measurement SW: DASY52, Version 52.8 (8); SEMCAD X Version 14.6.10 (7331)

835 MHz System Verification

Area Scan (7x14x1): Measurement grid: dx=15mm, dy=15mm

Zoom Scan (5x5x7)/Cube 0: Measurement grid: dx=8mm, dy=8mm, dz=5mm

Input Power = 20.0 dBm (100 mW)

Peak SAR (extrapolated) = 1.44 W/kg

SAR(1 g) = 0.967 W/kg

Deviation = 3.42%

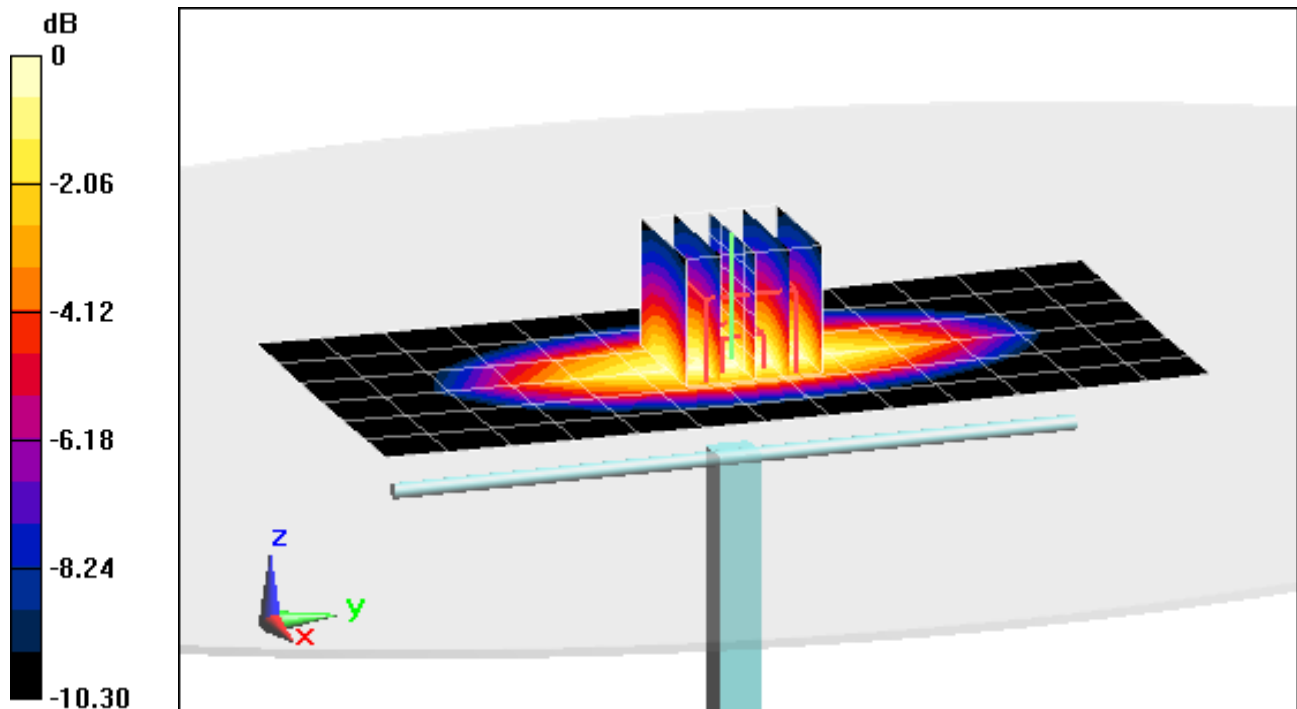

0 dB = 1.13 W/kg = 0.53 dBW/kg

PCTEST ENGINEERING LABORATORY, INC.

DUT: Dipole 1750 MHz; Type: D1765V2; Serial: 1008

Communication System: UID 0, CW; Frequency: 1750 MHz; Duty Cycle: 1:1

Medium: 1750 Body, Medium parameters used:

$f = 1750 \text{ MHz}$; $\sigma = 1.469 \text{ S/m}$; $\epsilon_r = 51.413$; $\rho = 1000 \text{ kg/m}^3$

Phantom section: Flat Section; Space: 1.0 cm

Test Date: 12-17-2014; Ambient Temp: 22.0°C; Tissue Temp: 21.0°C

Probe: ES3DV2 - SN3022; ConvF(4.7, 4.7, 4.7); Calibrated: 8/19/2014;

Sensor-Surface: 3mm (Mechanical Surface Detection)

Electronics: DAE4 Sn1322; Calibrated: 8/12/2014

Phantom: ELI v5.0; Type: QDOVA001BB; Serial: 1226

Measurement SW: DASY52, Version 52.8 (8); SEMCAD X Version 14.6.10 (7331)

1750 MHz System Verification

Area Scan (7x9x1): Measurement grid: dx=15mm, dy=15mm

Zoom Scan (5x5x7)/Cube 0: Measurement grid: dx=8mm, dy=8mm, dz=5mm

Input Power = 20.0 dBm (100 mW)

Peak SAR (extrapolated) = 6.67 W/kg

SAR(1 g) = 3.81 W/kg

Deviation = 1.33%

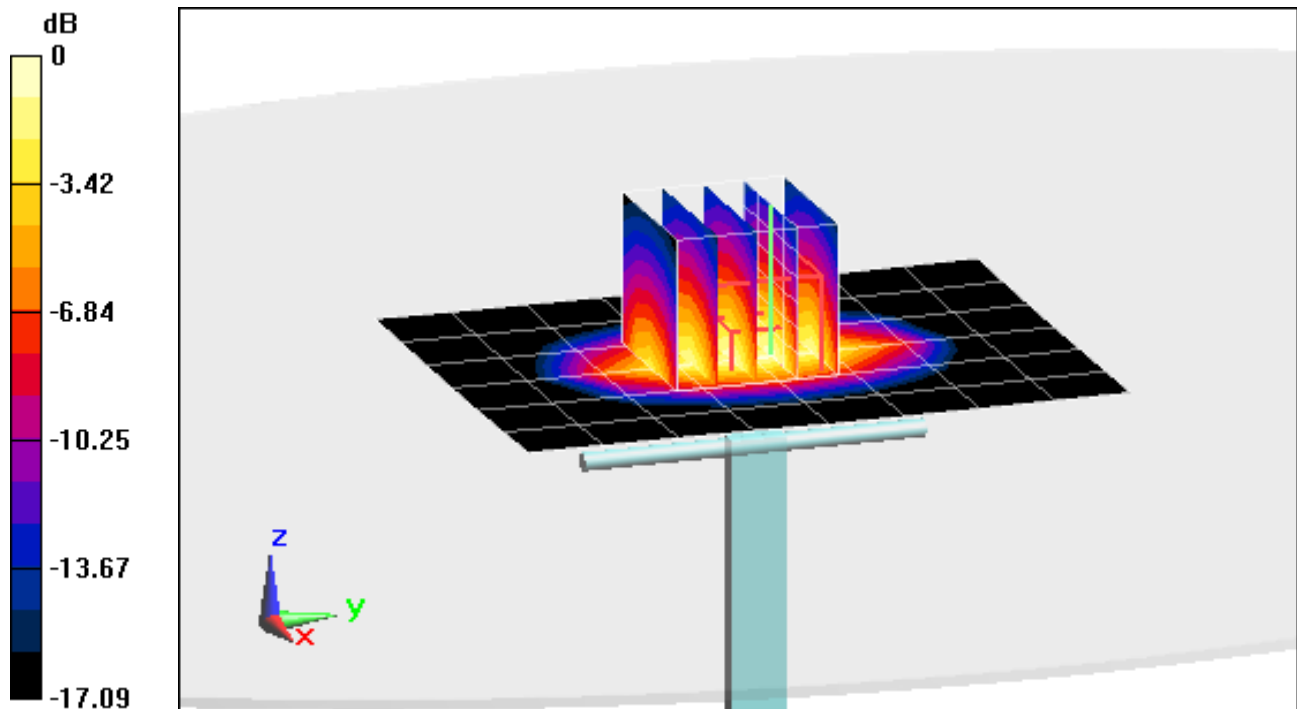

0 dB = 4.68 W/kg = 6.70 dBW/kg

PCTEST ENGINEERING LABORATORY, INC.

DUT: Dipole 1750 MHz; Type: D1765V2; Serial: 1008

Communication System: UID 0, CW; Frequency: 1750 MHz; Duty Cycle: 1:1

Medium: 1750 Body, Medium parameters used:

$f = 1750 \text{ MHz}$; $\sigma = 1.543 \text{ S/m}$; $\epsilon_r = 52.013$; $\rho = 1000 \text{ kg/m}^3$

Phantom section: Flat Section; Space: 1.0 cm

Test Date: 12-22-2014; Ambient Temp: 23.6°C; Tissue Temp: 21.8°C

Probe: ES3DV3 - SN3258; ConvF(4.83, 4.83, 4.83); Calibrated: 2/25/2014;

Sensor-Surface: 3mm (Mechanical Surface Detection)

Electronics: DAE4 Sn665; Calibrated: 2/26/2014

Phantom: ELI v5.0; Type: QDOVA002AA; Serial: TP-1158

Measurement SW: DASY52, Version 52.8 (8); SEMCAD X Version 14.6.10 (7331)

1750 MHz System Verification

Area Scan (7x9x1): Measurement grid: dx=15mm, dy=15mm

Zoom Scan (5x5x7)/Cube 0: Measurement grid: dx=8mm, dy=8mm, dz=5mm

Input Power = 20.0 dBm (100 mW)

Peak SAR (extrapolated) = 6.30 W/kg

SAR(1 g) = 3.69 W/kg

Deviation = -1.86%

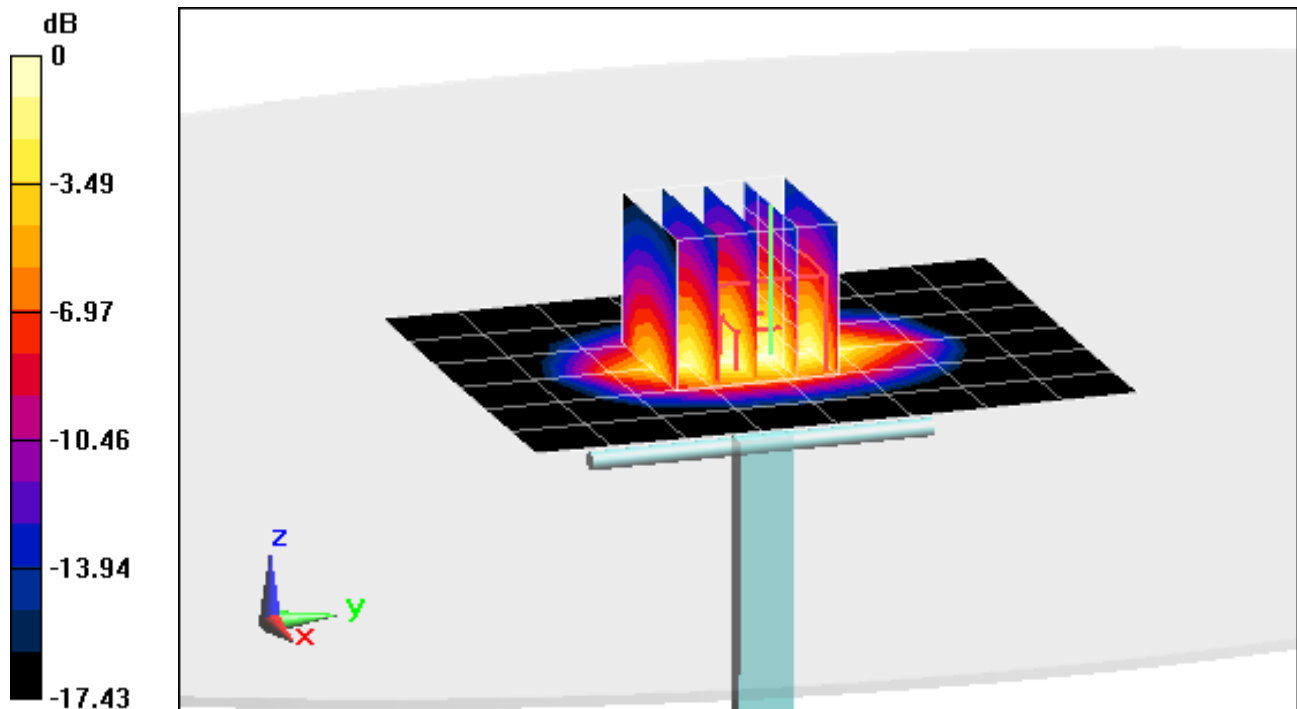

0 dB = 4.56 W/kg = 6.59 dBW/kg

PCTEST ENGINEERING LABORATORY, INC.

DUT: Dipole 1900 MHz; Type: D1900V2; Serial: 5d141

Communication System: UID 0, CW; Frequency: 1900 MHz; Duty Cycle: 1:1

Medium: 1900 Body, Medium parameters used (interpolated):

$f = 1900 \text{ MHz}$; $\sigma = 1.577 \text{ S/m}$; $\epsilon_r = 52.266$; $\rho = 1000 \text{ kg/m}^3$

Phantom section: Flat Section; Space: 1.0 cm

Test Date: 12-19-2014; Ambient Temp: 24.5°C; Tissue Temp: 22.2°C

Probe: ES3DV3 - SN3209; ConvF(4.68, 4.68, 4.68); Calibrated: 3/19/2014;

Sensor-Surface: 3mm (Mechanical Surface Detection)

Electronics: DAE4 Sn1334; Calibrated: 3/17/2014

Phantom: ELI Front; Type: QDOVA002AA; Serial: TP:1202

Measurement SW: DASY52, Version 52.8 (8); SEMCAD X Version 14.6.10 (7331)

1900 MHz System Verification

Area Scan (7x10x1): Measurement grid: dx=15mm, dy=15mm

Zoom Scan (5x5x7)/Cube 0: Measurement grid: dx=8mm, dy=8mm, dz=5mm

Input Power = 20.0 dBm (100 mW)

Peak SAR (extrapolated) = 7.43 W/kg

SAR(1 g) = 4.26 W/kg

Deviation = 4.93%

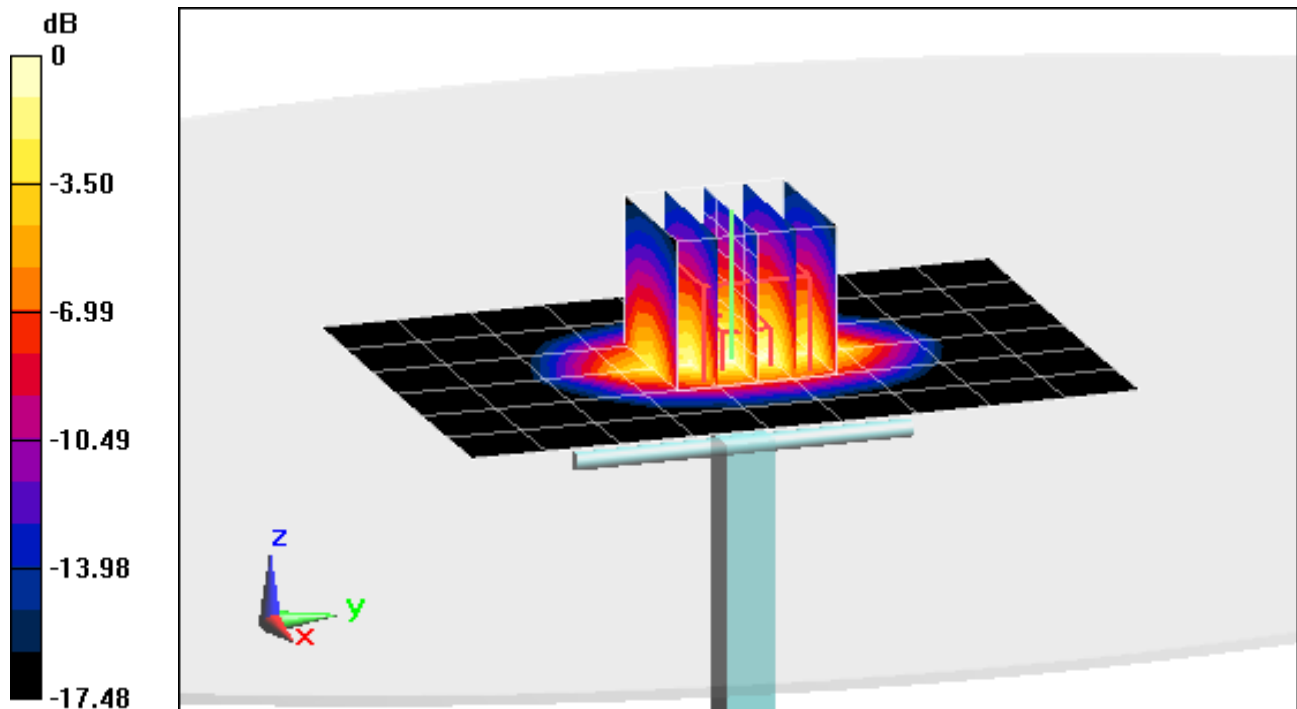

0 dB = 5.35 W/kg = 7.28 dBW/kg

PCTEST ENGINEERING LABORATORY, INC.

DUT: Dipole 1900 MHz; Type: D1900V2; Serial: 5d141

Communication System: UID 0, CW; Frequency: 1900 MHz; Duty Cycle: 1:1

Medium: 1900 Body, Medium parameters used (interpolated):

$f = 1900$ MHz; $\sigma = 1.515$ S/m; $\epsilon_r = 52.692$; $\rho = 1000$ kg/m³

Phantom section: Flat Section; Space: 1.0 cm

Test Date: 01-08-2015; Ambient Temp: 23.6°C; Tissue Temp: 22.5°C

Probe: ES3DV3 - SN3258; ConvF(4.61, 4.61, 4.61); Calibrated: 2/25/2014;

Sensor-Surface: 3mm (Mechanical Surface Detection)

Electronics: DAE4 Sn665; Calibrated: 2/26/2014

Phantom: ELI v5.0; Type: QDOVA002AA; Serial: TP-1158

Measurement SW: DASY52, Version 52.8 (8); SEMCAD X Version 14.6.10 (7331)

1900 MHz System Verification

Area Scan (7x10x1): Measurement grid: dx=15mm, dy=15mm

Zoom Scan (5x5x7)/Cube 0: Measurement grid: dx=8mm, dy=8mm, dz=5mm

Input Power = 20.0 dBm (100 mW)

Peak SAR (extrapolated) = 6.99 W/kg

SAR(1 g) = 4.05 W/kg

Deviation = -0.25%

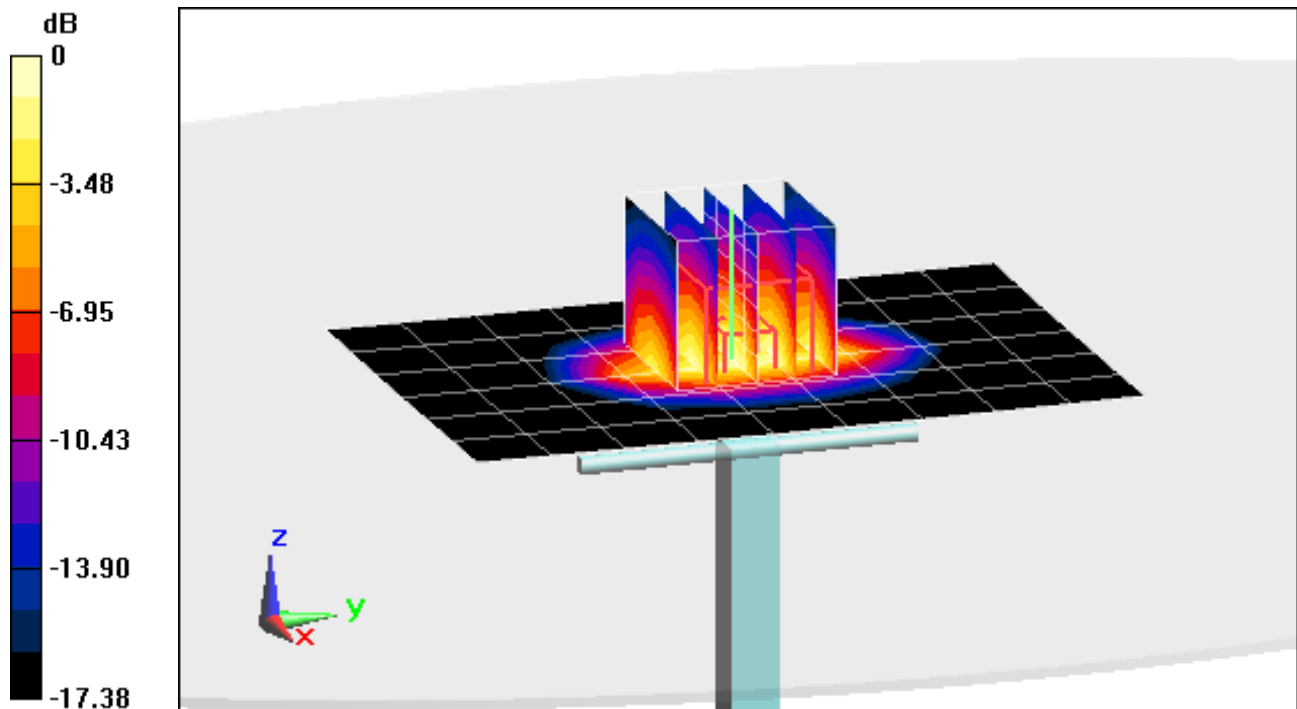

0 dB = 5.08 W/kg = 7.06 dBW/kg

APPENDIX C: PROBE CALIBRATION



Accredited by the Swiss Accreditation Service (SAS)
The Swiss Accreditation Service is one of the signatories to the EA
Multilateral Agreement for the recognition of calibration certificates

Accreditation No.: **SCS 108**

Client **PC Test**

Certificate No: **D750V3-1054_Mar14**

CALIBRATION CERTIFICATE

Object **D750V3 - SN: 1054**

Calibration procedure(s) **QA CAL-05.v9
Calibration procedure for dipole validation kits above 700 MHz**

Calibration date: **March 17, 2014**

*CCV
3/28/14*

This calibration certificate documents the traceability to national standards, which realize the physical units of measurements (SI).
The measurements and the uncertainties with confidence probability are given on the following pages and are part of the certificate.

All calibrations have been conducted in the closed laboratory facility: environment temperature (22 ± 3)°C and humidity < 70%.

Calibration Equipment used (M&TE critical for calibration)

Primary Standards	ID #	Cal Date (Certificate No.)	Scheduled Calibration
Power meter EPM-442A	GB37480704	09-Oct-13 (No. 217-01827)	Oct-14
Power sensor HP 8481A	US37292783	09-Oct-13 (No. 217-01827)	Oct-14
Power sensor HP 8481A	MY41092317	09-Oct-13 (No. 217-01828)	Oct-14
Reference 20 dB Attenuator	SN: 5058 (20k)	04-Apr-13 (No. 217-01736)	Apr-14
Type-N mismatch combination	SN: 5047.3 / 06327	04-Apr-13 (No. 217-01739)	Apr-14
Reference Probe ES3DV3	SN: 3205	30-Dec-13 (No. ES3-3205_Dec13)	Dec-14
DAE4	SN: 601	25-Apr-13 (No. DAE4-601_Apr13)	Apr-14

Secondary Standards	ID #	Check Date (in house)	Scheduled Check
RF generator R&S SMT-06	100005	04-Aug-99 (in house check Oct-13)	In house check: Oct-16
Network Analyzer HP 8753E	US37390585 S4206	18-Oct-01 (in house check Oct-13)	In house check: Oct-14

Calibrated by: **Israe El-Naouq** Name: **Israe El-Naouq** Function: **Laboratory Technician** Signature: *Israe El-Naouq*

Approved by: **Katja Pokovic** Name: **Katja Pokovic** Function: **Technical Manager** Signature: *Katja Pokovic*

Issued: March 17, 2014

This calibration certificate shall not be reproduced except in full without written approval of the laboratory.



Accredited by the Swiss Accreditation Service (SAS)
The Swiss Accreditation Service is one of the signatories to the EA
Multilateral Agreement for the recognition of calibration certificates

Accreditation No.: **SCS 108**

Glossary:

TSL	tissue simulating liquid
ConvF	sensitivity in TSL / NORM x,y,z
N/A	not applicable or not measured

Calibration is Performed According to the Following Standards:

- IEEE Std 1528-2013, "IEEE Recommended Practice for Determining the Peak Spatial-Averaged Specific Absorption Rate (SAR) in the Human Head from Wireless Communications Devices: Measurement Techniques", June 2013
- IEC 62209-1, "Procedure to measure the Specific Absorption Rate (SAR) for hand-held devices used in close proximity to the ear (frequency range of 300 MHz to 3 GHz)", February 2005
- KDB 865664, "SAR Measurement Requirements for 100 MHz to 6 GHz"

Additional Documentation:

- DASY4/5 System Handbook

Methods Applied and Interpretation of Parameters:

- Measurement Conditions:* Further details are available from the Validation Report at the end of the certificate. All figures stated in the certificate are valid at the frequency indicated.
- Antenna Parameters with TSL:* The dipole is mounted with the spacer to position its feed point exactly below the center marking of the flat phantom section, with the arms oriented parallel to the body axis.
- Feed Point Impedance and Return Loss:* These parameters are measured with the dipole positioned under the liquid filled phantom. The impedance stated is transformed from the measurement at the SMA connector to the feed point. The Return Loss ensures low reflected power. No uncertainty required.
- Electrical Delay:* One-way delay between the SMA connector and the antenna feed point. No uncertainty required.
- SAR measured:* SAR measured at the stated antenna input power.
- SAR normalized:* SAR as measured, normalized to an input power of 1 W at the antenna connector.
- SAR for nominal TSL parameters:* The measured TSL parameters are used to calculate the nominal SAR result.

The reported uncertainty of measurement is stated as the standard uncertainty of measurement multiplied by the coverage factor $k=2$, which for a normal distribution corresponds to a coverage probability of approximately 95%.

Measurement Conditions

DASY system configuration, as far as not given on page 1.

DASY Version	DASY5	V52.8.7
Extrapolation	Advanced Extrapolation	
Phantom	Modular Flat Phantom	
Distance Dipole Center - TSL	15 mm	with Spacer
Zoom Scan Resolution	dx, dy, dz = 5 mm	
Frequency	750 MHz \pm 1 MHz	

Head TSL parameters

The following parameters and calculations were applied.

	Temperature	Permittivity	Conductivity
Nominal Head TSL parameters	22.0 °C	41.9	0.89 mho/m
Measured Head TSL parameters	(22.0 \pm 0.2) °C	40.6 \pm 6 %	0.92 mho/m \pm 6 %
Head TSL temperature change during test	< 0.5 °C	----	----

SAR result with Head TSL

SAR averaged over 1 cm³ (1 g) of Head TSL	Condition	
SAR measured	250 mW input power	2.15 W/kg
SAR for nominal Head TSL parameters	normalized to 1W	8.33 W/kg \pm 17.0 % (k=2)

SAR averaged over 10 cm³ (10 g) of Head TSL	condition	
SAR measured	250 mW input power	1.39 W/kg
SAR for nominal Head TSL parameters	normalized to 1W	5.42 W/kg \pm 16.5 % (k=2)

Body TSL parameters

The following parameters and calculations were applied.

	Temperature	Permittivity	Conductivity
Nominal Body TSL parameters	22.0 °C	55.5	0.96 mho/m
Measured Body TSL parameters	(22.0 \pm 0.2) °C	55.2 \pm 6 %	1.00 mho/m \pm 6 %
Body TSL temperature change during test	< 0.5 °C	----	----

SAR result with Body TSL

SAR averaged over 1 cm³ (1 g) of Body TSL	Condition	
SAR measured	250 mW input power	2.23 W/kg
SAR for nominal Body TSL parameters	normalized to 1W	8.64 W/kg \pm 17.0 % (k=2)

SAR averaged over 10 cm³ (10 g) of Body TSL	condition	
SAR measured	250 mW input power	1.46 W/kg
SAR for nominal Body TSL parameters	normalized to 1W	5.69 W/kg \pm 16.5 % (k=2)

Appendix

Antenna Parameters with Head TSL

Impedance, transformed to feed point	55.1 Ω + 0.7 j Ω
Return Loss	- 26.2 dB

Antenna Parameters with Body TSL

Impedance, transformed to feed point	48.5 Ω - 2.8 j Ω
Return Loss	- 29.8 dB

General Antenna Parameters and Design

Electrical Delay (one direction)	1.035 ns
----------------------------------	----------

After long term use with 100W radiated power, only a slight warming of the dipole near the feedpoint can be measured.

The dipole is made of standard semirigid coaxial cable. The center conductor of the feeding line is directly connected to the second arm of the dipole. The antenna is therefore short-circuited for DC-signals. On some of the dipoles, small end caps are added to the dipole arms in order to improve matching when loaded according to the position as explained in the "Measurement Conditions" paragraph. The SAR data are not affected by this change. The overall dipole length is still according to the Standard.

No excessive force must be applied to the dipole arms, because they might bend or the soldered connections near the feedpoint may be damaged.

Additional EUT Data

Manufactured by	SPEAG
Manufactured on	November 08, 2011

DASY5 Validation Report for Head TSL

Date: 17.03.2014

Test Laboratory: SPEAG, Zurich, Switzerland

DUT: Dipole 750 MHz; Type: D750V3; Serial: D750V3 - SN: 1054

Communication System: UID 0 - CW; Frequency: 750 MHz

Medium parameters used: $f = 750$ MHz; $\sigma = 0.92$ S/m; $\epsilon_r = 40.6$; $\rho = 1000$ kg/m³

Phantom section: Flat Section

Measurement Standard: DASY5 (IEEE/IEC/ANSI C63.19-2007)

DASY52 Configuration:

- Probe: ES3DV3 - SN3205; ConvF(6.37, 6.37, 6.37); Calibrated: 30.12.2013;
- Sensor-Surface: 3mm (Mechanical Surface Detection)
- Electronics: DAE4 Sn601; Calibrated: 25.04.2013
- Phantom: Flat Phantom 4.9L; Type: QD000P49AA; Serial: 1001
- DASY52 52.8.7(1137); SEMCAD X 14.6.10(7164)

Dipole Calibration for Head Tissue/Pin=250 mW, d=15mm/Zoom Scan (7x7x7)/Cube 0:

Measurement grid: dx=5mm, dy=5mm, dz=5mm

Reference Value = 53.851 V/m; Power Drift = 0.02 dB

Peak SAR (extrapolated) = 3.25 W/kg

SAR(1 g) = 2.15 W/kg; SAR(10 g) = 1.39 W/kg

Maximum value of SAR (measured) = 2.51 W/kg

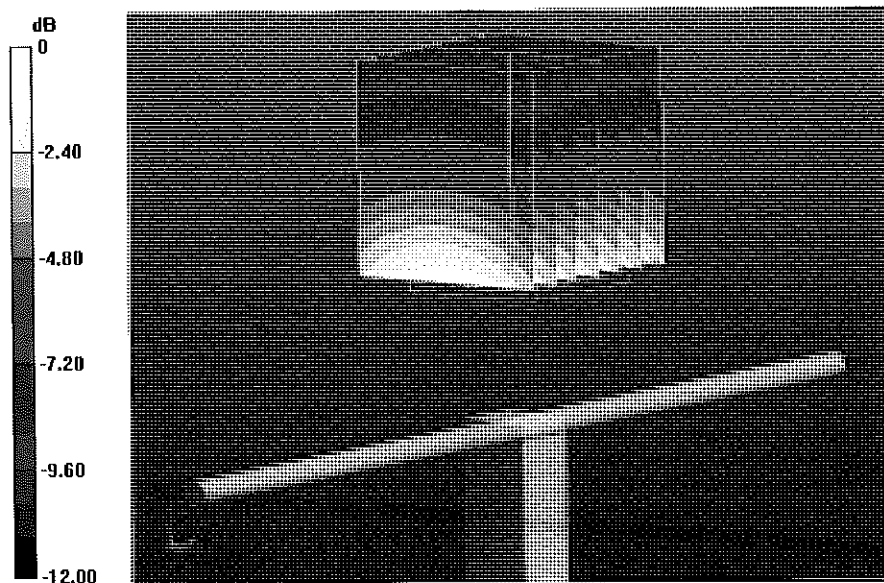

0 dB = 2.51 W/kg = 4.00 dBW/kg

Impedance Measurement Plot for Head TSL

17 Mar 2014 15:32:32

CH1 S11 1 U FS 2: 55.090 Ω 0.6895 Δ 146.31 pH 750.000 000 MHz

*
De1
CA

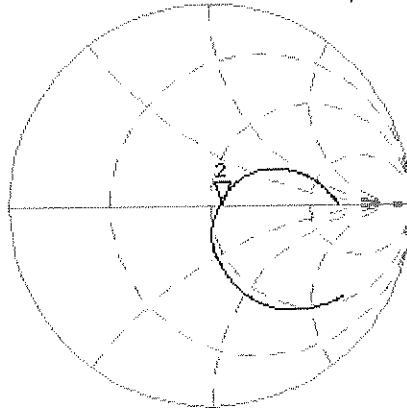

Avg
16
H1d

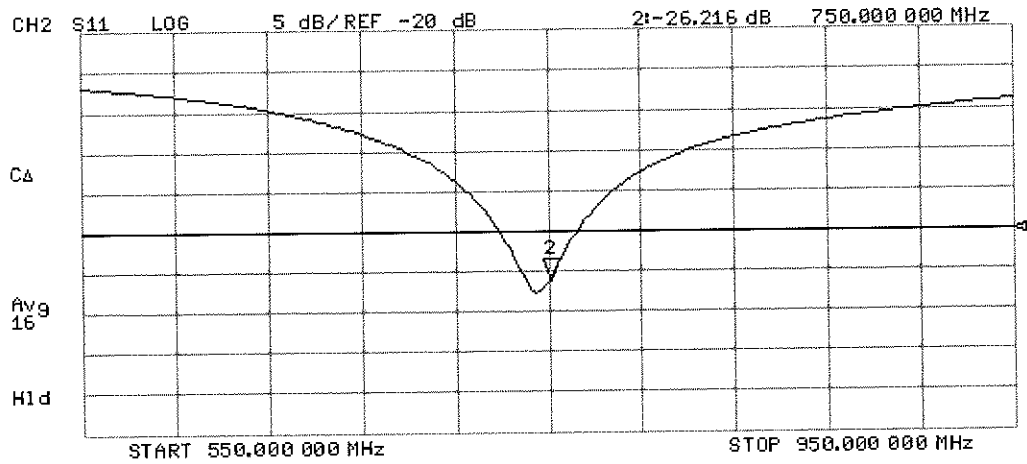

DASY5 Validation Report for Body TSL

Date: 14.03.2014

Test Laboratory: SPEAG, Zurich, Switzerland

DUT: Dipole 750 MHz; Type: D750V3; Serial: D750V3 - SN: 1054

Communication System: UID 0 - CW; Frequency: 750 MHz

Medium parameters used: $f = 750$ MHz; $\sigma = 1$ S/m; $\epsilon_r = 55.2$; $\rho = 1000$ kg/m³

Phantom section: Flat Section

Measurement Standard: DASY5 (IEEE/IEC/ANSI C63.19-2007)

DASY52 Configuration:

- Probe: ES3DV3 - SN3205; ConvF(6.13, 6.13, 6.13); Calibrated: 30.12.2013;
- Sensor-Surface: 3mm (Mechanical Surface Detection)
- Electronics: DAE4 Sn601; Calibrated: 25.04.2013
- Phantom: Flat Phantom 4.9L; Type: QD000P49AA; Serial: 1001
- DASY52 52.8.7(1137); SEMCAD X 14.6.10(7164)

Dipole Calibration for Body Tissue/Pin=250 mW, d=15mm/Zoom Scan (7x7x7)/Cube 0:

Measurement grid: dx=5mm, dy=5mm, dz=5mm

Reference Value = 52.788 V/m; Power Drift = -0.03 dB

Peak SAR (extrapolated) = 3.27 W/kg

SAR(1 g) = 2.23 W/kg; SAR(10 g) = 1.46 W/kg

Maximum value of SAR (measured) = 2.59 W/kg

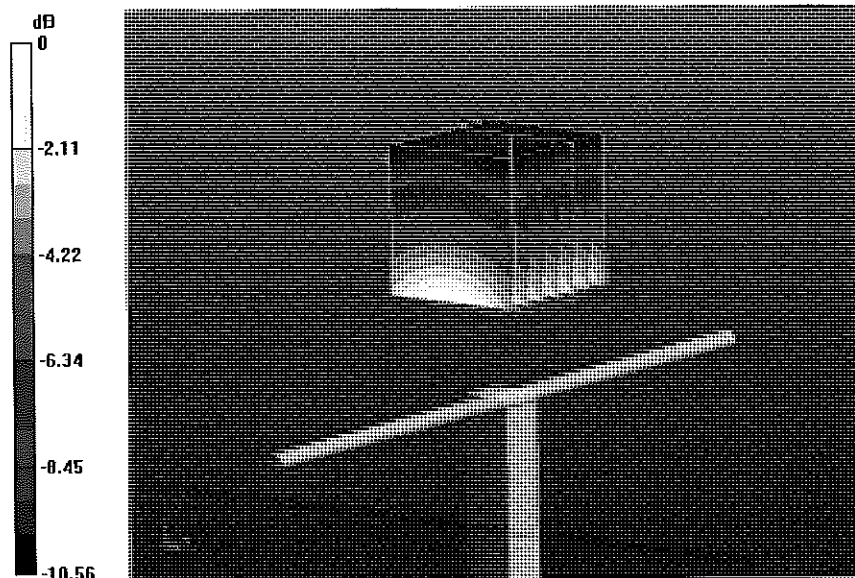

0 dB = 2.59 W/kg = 4.13 dBW/kg

Impedance Measurement Plot for Body TSL

14 Mar 2014 17:44:13

CH1 S11 1 U FS

1: 48.496 Ω -2.8066 Ω 75.609 pF

750.000 000 MHz

*
Del
CA

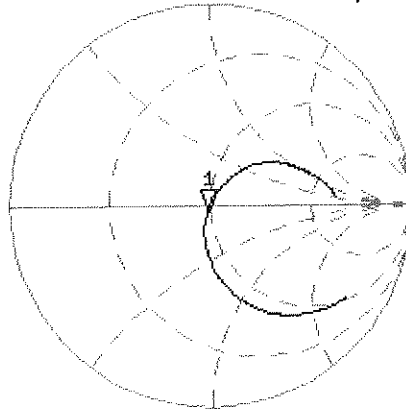

avg
16

H1 d

CH2 S11 LOG 5 dB/REF -20 dB 1: -29.812 dB 750.000 000 MHz

CA

avg
16

H1 d

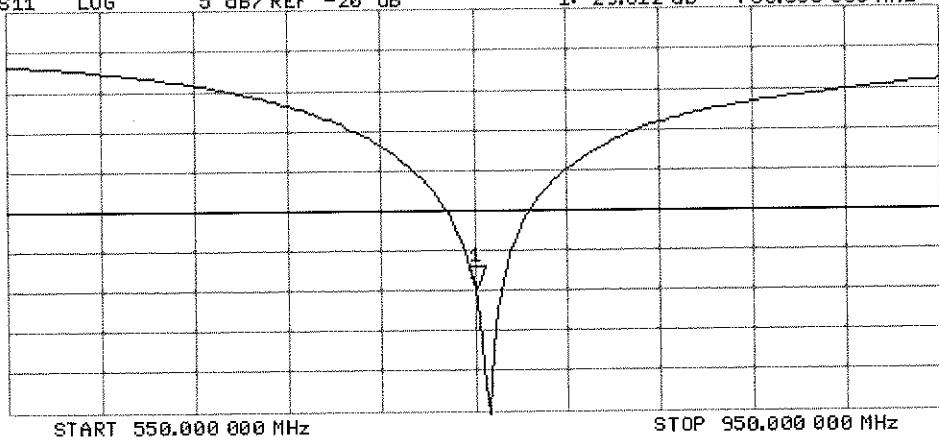



Accredited by the Swiss Accreditation Service (SAS)
The Swiss Accreditation Service is one of the signatories to the EA
Multilateral Agreement for the recognition of calibration certificates

Accreditation No.: **SCS 108**

Client **PC Test**

Certificate No: **D835V2-4d119_Apr14**

CALIBRATION CERTIFICATE

Object **D835V2 - SN: 4d119**

Calibration procedure(s) **QA CAL-05.v9**
Calibration procedure for dipole validation kits above 700 MHz

OCV
4/25/14

Calibration date: **April 07, 2014**

This calibration certificate documents the traceability to national standards, which realize the physical units of measurements (SI).
The measurements and the uncertainties with confidence probability are given on the following pages and are part of the certificate.

All calibrations have been conducted in the closed laboratory facility: environment temperature (22 ± 3)°C and humidity < 70%.

Calibration Equipment used (M&TE critical for calibration)

Primary Standards	ID #	Cal Date (Certificate No.)	Scheduled Calibration
Power meter EPM-442A	GB37480704	09-Oct-13 (No. 217-01827)	Oct-14
Power sensor HP 8481A	US37292783	09-Oct-13 (No. 217-01827)	Oct-14
Power sensor HP 8481A	MY41092317	09-Oct-13 (No. 217-01828)	Oct-14
Reference 20 dB Attenuator	SN: 5058 (20k)	03-Apr-14 (No. 217-01918)	Apr-15
Type-N mismatch combination	SN: 5047.2 / 06327	03-Apr-14 (No. 217-01921)	Apr-15
Reference Probe ES3DV3	SN: 3205	30-Dec-13 (No. ES3-3205_Dec13)	Dec-14
DAE4	SN: 601	25-Apr-13 (No. DAE4-601_Apr13)	Apr-14
Secondary Standards	ID #	Check Date (in house)	Scheduled Check
RF generator R&S SMT-06	100005	04-Aug-99 (in house check Oct-13)	In house check: Oct-16
Network Analyzer HP 8753E	US37390585 S4206	18-Oct-01 (in house check Oct-13)	In house check: Oct-14

Calibrated by: **Leif Klynsner** Function: **Laboratory Technician**

Signature: *Leif Klynsner*

Approved by: **Katja Pokovic** Technical Manager

Katja Pokovic

Issued: April 9, 2014

This calibration certificate shall not be reproduced except in full without written approval of the laboratory.



Accredited by the Swiss Accreditation Service (SAS)
The Swiss Accreditation Service is one of the signatories to the EA
Multilateral Agreement for the recognition of calibration certificates

Accreditation No.: **SCS 108**

Glossary:

TSL	tissue simulating liquid
ConvF	sensitivity in TSL / NORM x,y,z
N/A	not applicable or not measured

Calibration is Performed According to the Following Standards:

- a) IEEE Std 1528-2013, "IEEE Recommended Practice for Determining the Peak Spatial-Averaged Specific Absorption Rate (SAR) in the Human Head from Wireless Communications Devices: Measurement Techniques", June 2013
- b) IEC 62209-1, "Procedure to measure the Specific Absorption Rate (SAR) for hand-held devices used in close proximity to the ear (frequency range of 300 MHz to 3 GHz)", February 2005
- c) KDB 865664, "SAR Measurement Requirements for 100 MHz to 6 GHz"

Additional Documentation:

- d) DASY4/5 System Handbook

Methods Applied and Interpretation of Parameters:

- *Measurement Conditions:* Further details are available from the Validation Report at the end of the certificate. All figures stated in the certificate are valid at the frequency indicated.
- *Antenna Parameters with TSL:* The dipole is mounted with the spacer to position its feed point exactly below the center marking of the flat phantom section, with the arms oriented parallel to the body axis.
- *Feed Point Impedance and Return Loss:* These parameters are measured with the dipole positioned under the liquid filled phantom. The impedance stated is transformed from the measurement at the SMA connector to the feed point. The Return Loss ensures low reflected power. No uncertainty required.
- *Electrical Delay:* One-way delay between the SMA connector and the antenna feed point. No uncertainty required.
- *SAR measured:* SAR measured at the stated antenna input power.
- *SAR normalized:* SAR as measured, normalized to an input power of 1 W at the antenna connector.
- *SAR for nominal TSL parameters:* The measured TSL parameters are used to calculate the nominal SAR result.

The reported uncertainty of measurement is stated as the standard uncertainty of measurement multiplied by the coverage factor $k=2$, which for a normal distribution corresponds to a coverage probability of approximately 95%.

Measurement Conditions

DASY system configuration, as far as not given on page 1.

DASY Version	DASY5	V52.8.7
Extrapolation	Advanced Extrapolation	
Phantom	Modular Flat Phantom	
Distance Dipole Center - TSL	15 mm	with Spacer
Zoom Scan Resolution	dx, dy, dz = 5 mm	
Frequency	835 MHz ± 1 MHz	

Head TSL parameters

The following parameters and calculations were applied.

	Temperature	Permittivity	Conductivity
Nominal Head TSL parameters	22.0 °C	41.5	0.90 mho/m
Measured Head TSL parameters	(22.0 ± 0.2) °C	41.6 ± 6 %	0.94 mho/m ± 6 %
Head TSL temperature change during test	< 0.5 °C	----	----

SAR result with Head TSL

SAR averaged over 1 cm ³ (1 g) of Head TSL	Condition	
SAR measured	250 mW input power	2.38 W/kg
SAR for nominal Head TSL parameters	normalized to 1W	9.22 W/kg ± 17.0 % (k=2)

SAR averaged over 10 cm ³ (10 g) of Head TSL	condition	
SAR measured	250 mW input power	1.53 W/kg
SAR for nominal Head TSL parameters	normalized to 1W	5.97 W/kg ± 16.5 % (k=2)

Body TSL parameters

The following parameters and calculations were applied.

	Temperature	Permittivity	Conductivity
Nominal Body TSL parameters	22.0 °C	55.2	0.97 mho/m
Measured Body TSL parameters	(22.0 ± 0.2) °C	53.6 ± 6 %	1.02 mho/m ± 6 %
Body TSL temperature change during test	< 0.5 °C	----	----

SAR result with Body TSL

SAR averaged over 1 cm ³ (1 g) of Body TSL	Condition	
SAR measured	250 mW input power	2.44 W/kg
SAR for nominal Body TSL parameters	normalized to 1W	9.34 W/kg ± 17.0 % (k=2)

SAR averaged over 10 cm ³ (10 g) of Body TSL	condition	
SAR measured	250 mW input power	1.59 W/kg
SAR for nominal Body TSL parameters	normalized to 1W	6.15 W/kg ± 16.5 % (k=2)

Appendix

Antenna Parameters with Head TSL

Impedance, transformed to feed point	51.2 Ω - 1.6 j Ω
Return Loss	- 34.0 dB

Antenna Parameters with Body TSL

Impedance, transformed to feed point	46.3 Ω - 4.5 j Ω
Return Loss	- 24.4 dB

General Antenna Parameters and Design

Electrical Delay (one direction)	1.386 ns
----------------------------------	----------

After long term use with 100W radiated power, only a slight warming of the dipole near the feedpoint can be measured.

The dipole is made of standard semirigid coaxial cable. The center conductor of the feeding line is directly connected to the second arm of the dipole. The antenna is therefore short-circuited for DC-signals. On some of the dipoles, small end caps are added to the dipole arms in order to improve matching when loaded according to the position as explained in the "Measurement Conditions" paragraph. The SAR data are not affected by this change. The overall dipole length is still according to the Standard.

No excessive force must be applied to the dipole arms, because they might bend or the soldered connections near the feedpoint may be damaged.

Additional EUT Data

Manufactured by	SPEAG
Manufactured on	June 29, 2010

DASY5 Validation Report for Head TSL

Date: 07.04.2014

Test Laboratory: SPEAG, Zurich, Switzerland

DUT: Dipole 835 MHz; Type: D835V2; Serial: D835V2 - SN: 4d119

Communication System: UID 0 - CW; Frequency: 835 MHz

Medium parameters used: $f = 835$ MHz; $\sigma = 0.94$ S/m; $\epsilon_r = 41.6$; $\rho = 1000$ kg/m³

Phantom section: Flat Section

Measurement Standard: DASY5 (IEEE/IEC/ANSI C63.19-2007)

DASY52 Configuration:

- Probe: ES3DV3 - SN3205; ConvF(6.22, 6.22, 6.22); Calibrated: 30.12.2013;
- Sensor-Surface: 3mm (Mechanical Surface Detection)
- Electronics: DAE4 Sn601; Calibrated: 25.04.2013
- Phantom: Flat Phantom 4.9L; Type: QD000P49AA; Serial: 1001
- DASY52 52.8.7(1137); SEMCAD X 14.6.10(7164)

Dipole Calibration for Head Tissue/Pin=250 mW, d=15mm/Zoom Scan (7x7x7)/Cube 0:

Measurement grid: dx=5mm, dy=5mm, dz=5mm

Reference Value = 56.289 V/m; Power Drift = 0.01 dB

Peak SAR (extrapolated) = 3.59 W/kg

SAR(1 g) = 2.38 W/kg; SAR(10 g) = 1.53 W/kg

Maximum value of SAR (measured) = 2.80 W/kg

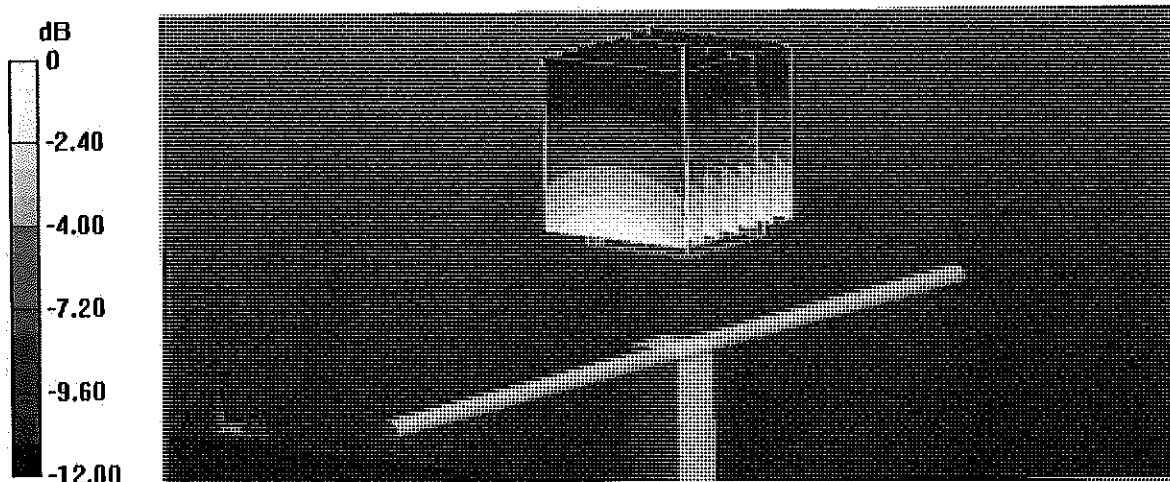

Impedance Measurement Plot for Head TSL

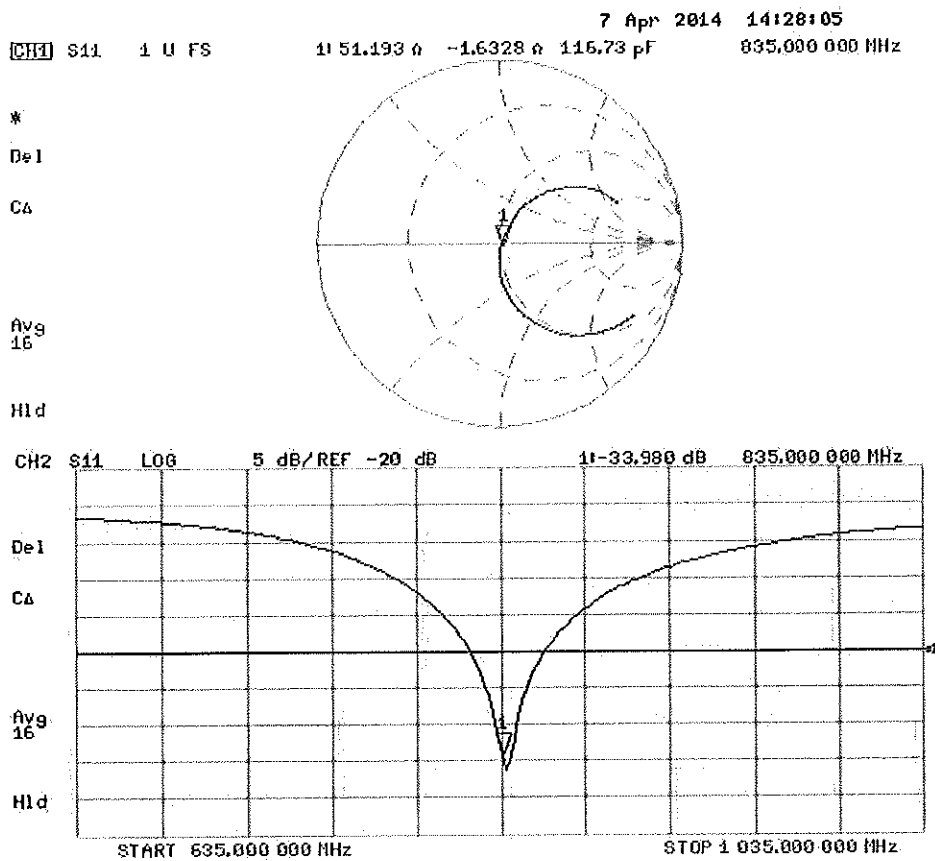

DASY5 Validation Report for Body TSL

Date: 07.04.2014

Test Laboratory: SPEAG, Zurich, Switzerland

DUT: Dipole 835 MHz; Type: D835V2; Serial: D835V2 - SN: 4d119

Communication System: UID 0 - CW; Frequency: 835 MHz

Medium parameters used: $f = 835 \text{ MHz}$; $\sigma = 1.02 \text{ S/m}$; $\epsilon_r = 53.6$; $\rho = 1000 \text{ kg/m}^3$

Phantom section: Flat Section

Measurement Standard: DASY5 (IEEE/IEC/ANSI C63.19-2007)

DASY52 Configuration:

- Probe: ES3DV3 - SN3205; ConvF(6.09, 6.09, 6.09); Calibrated: 30.12.2013;
- Sensor-Surface: 3mm (Mechanical Surface Detection)
- Electronics: DAE4 Sn601; Calibrated: 25.04.2013
- Phantom: Flat Phantom 4.9L; Type: QD000P49AA; Serial: 1001
- DASY52 52.8.7(1137); SEMCAD X 14.6.10(7164)

Dipole Calibration for Body Tissue/Pin=250 mW, d=15mm/Zoom Scan (7x7x7)/Cube 0:

Measurement grid: dx=5mm, dy=5mm, dz=5mm

Reference Value = 54.594 V/m; Power Drift = -0.01 dB

Peak SAR (extrapolated) = 3.61 W/kg

SAR(1 g) = 2.44 W/kg; SAR(10 g) = 1.59 W/kg

Maximum value of SAR (measured) = 2.85 W/kg

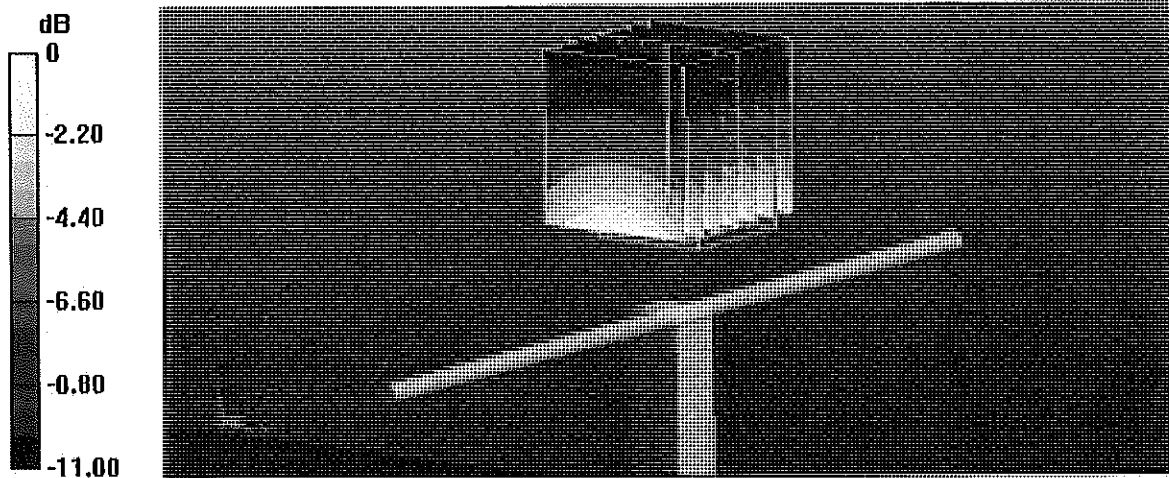

0 dB = 2.85 W/kg = 4.55 dBW/kg

Impedance Measurement Plot for Body TSL

7 Apr 2014 11:08:44
 [CH1] S11 1 U FS 1i 46.309 Ω -4.5078 Ω 42.203 pF 835.000 000 MHz

*
 Del
 CA
 Avg
 16
 H1d

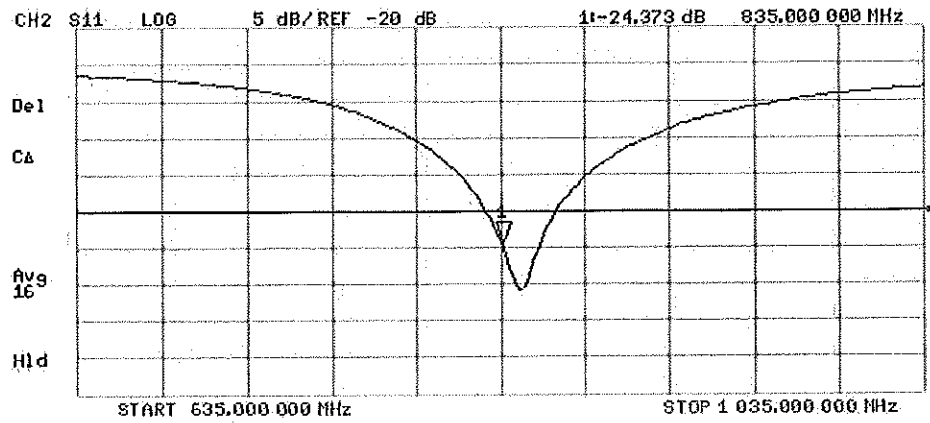
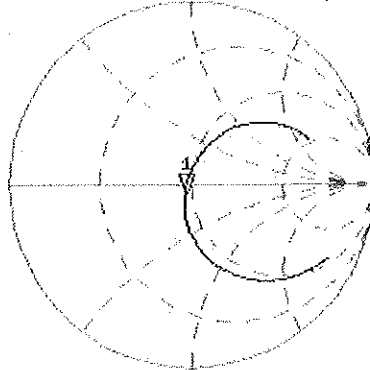

**Calibration Laboratory of
Schmid & Partner
Engineering AG**
Zeughausstrasse 43, 8004 Zurich, Switzerland



S Schweizerischer Kalibrierdienst
C Service suisse d'étalonnage
S Servizio svizzero di taratura
S Swiss Calibration Service

Accredited by the Swiss Accreditation Service (SAS)
The Swiss Accreditation Service is one of the signatories to the EA
Multilateral Agreement for the recognition of calibration certificates

Accreditation No.: **SCS 108**

Client **PC Test**

Certificate No: **D835V2-4d133_Jul14**

CALIBRATION CERTIFICATE

Object **D835V2 - SN: 4d133**

Calibration procedure(s) **QA CAL-05.v9
Calibration procedure for dipole validation kits above 700 MHz**

CC
W/G/M

Calibration date: **July 24, 2014**

This calibration certificate documents the traceability to national standards, which realize the physical units of measurements (SI).
The measurements and the uncertainties with confidence probability are given on the following pages and are part of the certificate.

All calibrations have been conducted in the closed laboratory facility: environment temperature (22 ± 3)°C and humidity < 70%.

Calibration Equipment used (M&TE critical for calibration)

Primary Standards	ID #	Cal Date (Certificate No.)	Scheduled Calibration
Power meter EPM-442A	GB37480704	09-Oct-13 (No. 217-01827)	Oct-14
Power sensor HP 8481A	US37292783	09-Oct-13 (No. 217-01827)	Oct-14
Power sensor HP 8481A	MY41092317	09-Oct-13 (No. 217-01828)	Oct-14
Reference 20 dB Attenuator	SN: 5058 (20k)	03-Apr-14 (No. 217-01918)	Apr-15
Type-N mismatch combination	SN: 5047.2 / 06327	03-Apr-14 (No. 217-01921)	Apr-15
Reference Probe ES3DV3	SN: 3205	30-Dec-13 (No. ES3-3205_Dec13)	Dec-14
DAE4	SN: 601	30-Apr-14 (No. DAE4-601_Apr14)	Apr-15
Secondary Standards	ID #	Check Date (in house)	Scheduled Check
RF generator R&S SMT-06	100005	04-Aug-99 (in house check Oct-13)	In house check: Oct-16
Network Analyzer HP 8763E	US37390585 S4206	18-Oct-01 (in house check Oct-13)	In house check: Oct-14

Calibrated by: **Jeton Kastrali** (Name), **Laboratory Technician** (Function), *[Signature]* (Signature)

Approved by: **Katja Pokovic** (Name), **Technical Manager** (Function), *[Signature]* (Signature)

Issued: July 24, 2014

This calibration certificate shall not be reproduced except in full without written approval of the laboratory.

**Calibration Laboratory of
Schmid & Partner
Engineering AG**
Zeughausstrasse 43, 8004 Zurich, Switzerland



S Schweizerischer Kalibrierdienst
C Service suisse d'étalonnage
S Servizio svizzero di taratura
S Swiss Calibration Service

Accredited by the Swiss Accreditation Service (SAS)
The Swiss Accreditation Service is one of the signatories to the EA
Multilateral Agreement for the recognition of calibration certificates

Accreditation No.: **SCS 108**

Glossary:

TSL	tissue simulating liquid
ConvF	sensitivity in TSL / NORM x,y,z
N/A	not applicable or not measured

Calibration is Performed According to the Following Standards:

- IEEE Std 1528-2013, "IEEE Recommended Practice for Determining the Peak Spatial-Averaged Specific Absorption Rate (SAR) in the Human Head from Wireless Communications Devices: Measurement Techniques", June 2013
- IEC 62209-1, "Procedure to measure the Specific Absorption Rate (SAR) for hand-held devices used in close proximity to the ear (frequency range of 300 MHz to 3 GHz)", February 2005
- KDB 865664, "SAR Measurement Requirements for 100 MHz to 6 GHz"

Additional Documentation:

- DASY4/5 System Handbook

Methods Applied and Interpretation of Parameters:

- Measurement Conditions:* Further details are available from the Validation Report at the end of the certificate. All figures stated in the certificate are valid at the frequency indicated.
- Antenna Parameters with TSL:* The dipole is mounted with the spacer to position its feed point exactly below the center marking of the flat phantom section, with the arms oriented parallel to the body axis.
- Feed Point Impedance and Return Loss:* These parameters are measured with the dipole positioned under the liquid filled phantom. The impedance stated is transformed from the measurement at the SMA connector to the feed point. The Return Loss ensures low reflected power. No uncertainty required.
- Electrical Delay:* One-way delay between the SMA connector and the antenna feed point. No uncertainty required.
- SAR measured:* SAR measured at the stated antenna input power.
- SAR normalized:* SAR as measured, normalized to an input power of 1 W at the antenna connector.
- SAR for nominal TSL parameters:* The measured TSL parameters are used to calculate the nominal SAR result.

The reported uncertainty of measurement is stated as the standard uncertainty of measurement multiplied by the coverage factor $k=2$, which for a normal distribution corresponds to a coverage probability of approximately 95%.

Measurement Conditions

DASY system configuration, as far as not given on page 1.

DASY Version	DASY5	V52.8.8
Extrapolation	Advanced Extrapolation	
Phantom	Modular Flat Phantom	
Distance Dipole Center - TSL	15 mm	with Spacer
Zoom Scan Resolution	dx, dy, dz = 5 mm	
Frequency	835 MHz ± 1 MHz	

Head TSL parameters

The following parameters and calculations were applied.

	Temperature	Permittivity	Conductivity
Nominal Head TSL parameters	22.0 °C	41.5	0.90 mho/m
Measured Head TSL parameters	(22.0 ± 0.2) °C	41.1 ± 6 %	0.94 mho/m ± 6 %
Head TSL temperature change during test	< 0.5 °C	----	----

SAR result with Head TSL

SAR averaged over 1 cm ³ (1 g) of Head TSL	Condition	
SAR measured	250 mW input power	2.38 W/kg
SAR for nominal Head TSL parameters	normalized to 1W	9.20 W/kg ± 17.0 % (k=2)

SAR averaged over 10 cm ³ (10 g) of Head TSL	condition	
SAR measured	250 mW input power	1.53 W/kg
SAR for nominal Head TSL parameters	normalized to 1W	5.96 W/kg ± 16.5 % (k=2)

Body TSL parameters

The following parameters and calculations were applied.

	Temperature	Permittivity	Conductivity
Nominal Body TSL parameters	22.0 °C	55.2	0.97 mho/m
Measured Body TSL parameters	(22.0 ± 0.2) °C	53.8 ± 6 %	1.02 mho/m ± 6 %
Body TSL temperature change during test	< 0.5 °C	----	----

SAR result with Body TSL

SAR averaged over 1 cm ³ (1 g) of Body TSL	Condition	
SAR measured	250 mW input power	2.44 W/kg
SAR for nominal Body TSL parameters	normalized to 1W	9.35 W/kg ± 17.0 % (k=2)

SAR averaged over 10 cm ³ (10 g) of Body TSL	condition	
SAR measured	250 mW input power	1.59 W/kg
SAR for nominal Body TSL parameters	normalized to 1W	6.15 W/kg ± 16.5 % (k=2)

Appendix (Additional assessments outside the scope of SCS108)

Antenna Parameters with Head TSL

Impedance, transformed to feed point	51.6 Ω - 1.0 $j\Omega$
Return Loss	- 34.7 dB

Antenna Parameters with Body TSL

Impedance, transformed to feed point	47.8 Ω - 3.3 $j\Omega$
Return Loss	- 27.8 dB

General Antenna Parameters and Design

Electrical Delay (one direction)	1.395 ns
----------------------------------	----------

After long term use with 100W radiated power, only a slight warming of the dipole near the feedpoint can be measured.

The dipole is made of standard semirigid coaxial cable. The center conductor of the feeding line is directly connected to the second arm of the dipole. The antenna is therefore short-circuited for DC-signals. On some of the dipoles, small end caps are added to the dipole arms in order to improve matching when loaded according to the position as explained in the "Measurement Conditions" paragraph. The SAR data are not affected by this change. The overall dipole length is still according to the Standard.

No excessive force must be applied to the dipole arms, because they might bend or the soldered connections near the feedpoint may be damaged.

Additional EUT Data

Manufactured by	SPEAG
Manufactured on	July 22, 2011

DASY5 Validation Report for Head TSL

Date: 24.07.2014

Test Laboratory: SPEAG, Zurich, Switzerland

DUT: Dipole 835 MHz; Type: D835V2; Serial: D835V2 - SN: 4d133

Communication System: UID 0 - CW; Frequency: 835 MHz

Medium parameters used: $f = 835$ MHz; $\sigma = 0.94$ S/m; $\epsilon_r = 41.1$; $\rho = 1000$ kg/m³

Phantom section: Flat Section

Measurement Standard: DASY5 (IEEE/IEC/ANSI C63.19-2011)

DASY52 Configuration:

- Probe: ES3DV3 - SN3205; ConvF(6.22, 6.22, 6.22); Calibrated: 30.12.2013;
- Sensor-Surface: 3mm (Mechanical Surface Detection)
- Electronics: DAE4 Sn601; Calibrated: 30.04.2014
- Phantom: Flat Phantom 4.9L; Type: QD000P49AA; Serial: 1001
- DASY52 52.8.8(1222); SEMCAD X 14.6.10(7331)

Dipole Calibration for Head Tissue/Pin=250 mW, d=15mm/Zoom Scan (7x7x7)/Cube 0:

Measurement grid: dx=5mm, dy=5mm, dz=5mm

Reference Value = 56.07 V/m; Power Drift = 0.03 dB

Peak SAR (extrapolated) = 3.58 W/kg

SAR(1 g) = 2.38 W/kg; SAR(10 g) = 1.53 W/kg

Maximum value of SAR (measured) = 2.79 W/kg

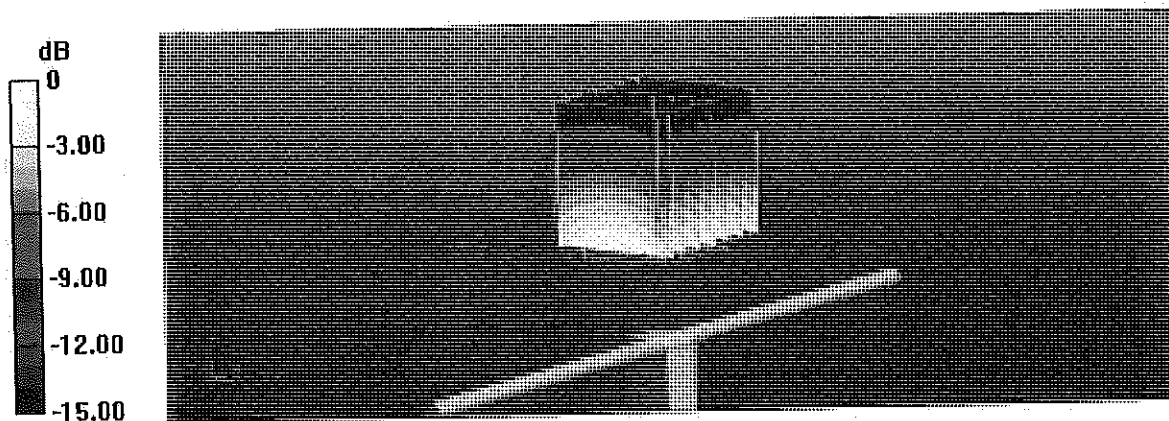

0 dB = 2.79 W/kg = 4.46 dBW/kg

Impedance Measurement Plot for Head TSL

24 Jul 2014 11:33:11

[CHI] S11 1 U FS

Z: 51.553 Ω -1.0293 Ω 105.19 pF 835.000 000 MHz

De1

CA

Avg
16

H1d

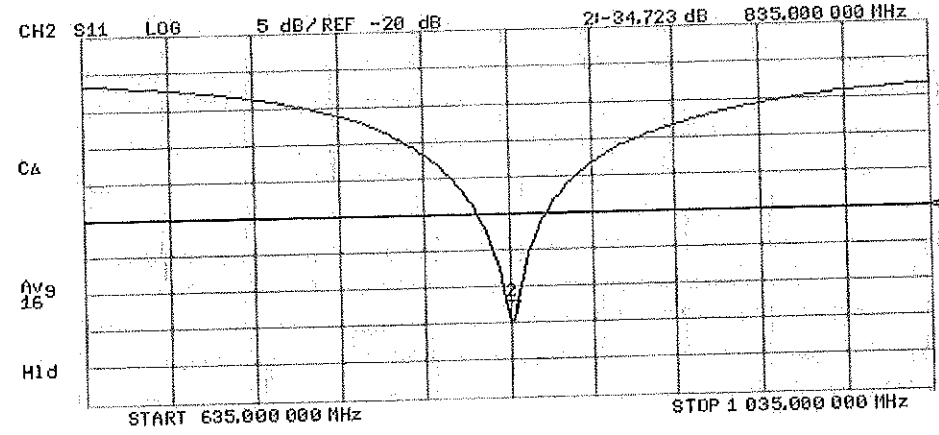
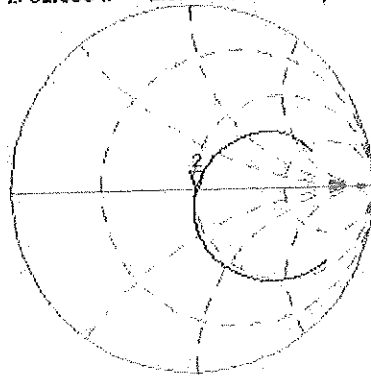

DASY5 Validation Report for Body TSL

Date: 17.07.2014

Test Laboratory: SPEAG, Zurich, Switzerland

DUT: Dipole 835 MHz; Type: D835V2; Serial: D835V2 - SN: 4d133

Communication System: UID 0 - CW; Frequency: 835 MHz
Medium parameters used: $f = 835$ MHz; $\sigma = 1.02$ S/m; $\epsilon_r = 53.8$; $\rho = 1000$ kg/m³
Phantom section: Flat Section
Measurement Standard: DASY5 (IEEE/IEC/ANSI C63.19-2011)

DASY52 Configuration:

- Probe: ES3DV3 - SN3205; ConvF(6.09, 6.09, 6.09); Calibrated: 30.12.2013;
- Sensor-Surface: 3mm (Mechanical Surface Detection)
- Electronics: DAE4 Sn601; Calibrated: 30.04.2014
- Phantom: Flat Phantom 4.9L; Type: QD000P49AA; Serial: 1001
- DASY52 52.8.8(1222); SEMCAD X 14.6.10(7331)

Dipole Calibration for Body Tissue/Pin=250 mW, d=15mm/Zoom Scan (7x7x7)/Cube 0:

Measurement grid: dx=5mm, dy=5mm, dz=5mm
Reference Value = 54.61 V/m; Power Drift = -0.01 dB
Peak SAR (extrapolated) = 3.59 W/kg
SAR(1 g) = 2.44 W/kg; SAR(10 g) = 1.59 W/kg
Maximum value of SAR (measured) = 2.84 W/kg

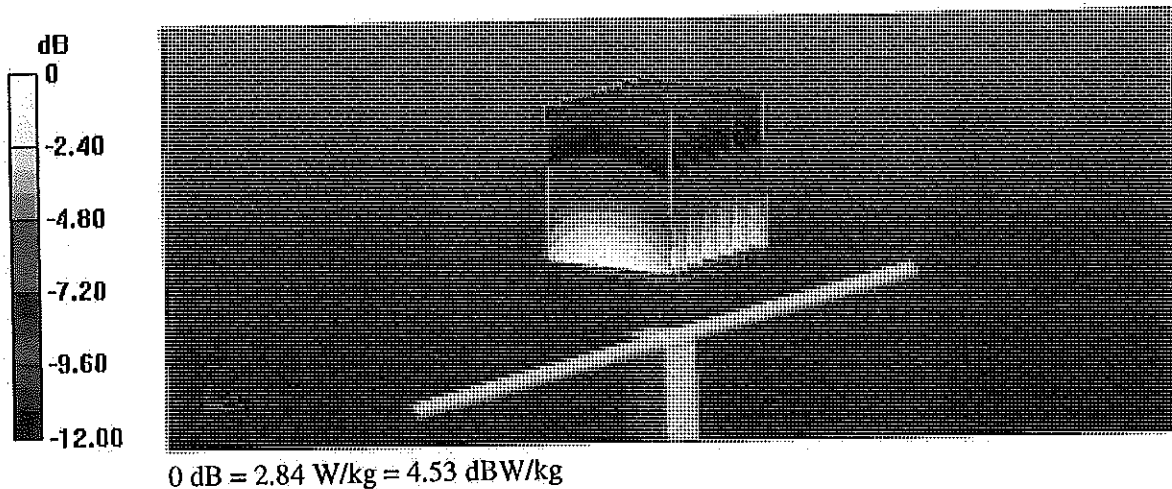

Impedance Measurement Plot for Body TSL

17 Jul 2014 13:43:24

CH1 S11 1 U F8

1: 47.799 Ω -3.3184 Ω 57.439 pF

835.000 000 MHz

*
Del
CA

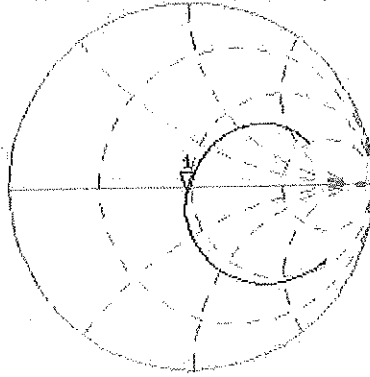

Avg
16

H1d

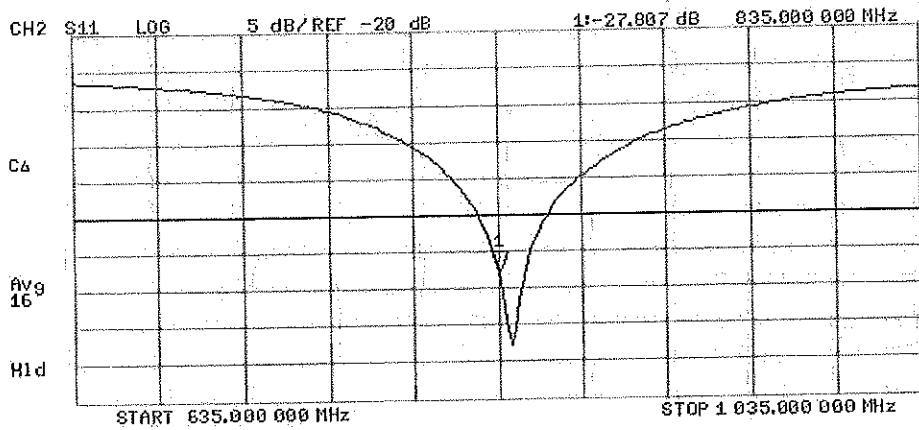



Accredited by the Swiss Accreditation Service (SAS)
The Swiss Accreditation Service is one of the signatories to the EA
Multilateral Agreement for the recognition of calibration certificates

Accreditation No.: **SCS 108**

Client **PC Test**

Certificate No: **D1765V2-1008_May14**

CALIBRATION CERTIFICATE

Object **D1765V2 - SN: 1008**

Calibration procedure(s) **QA CAL-05.v9
Calibration procedure for dipole validation kits above 700 MHz**

*CCV
6/2/14*

Calibration date: **May 07, 2014**

This calibration certificate documents the traceability to national standards, which realize the physical units of measurements (SI).
The measurements and the uncertainties with confidence probability are given on the following pages and are part of the certificate.

All calibrations have been conducted in the closed laboratory facility: environment temperature (22 ± 3)°C and humidity < 70%.

Calibration Equipment used (M&TE critical for calibration)

Primary Standards	ID #	Cal Date (Certificate No.)	Scheduled Calibration
Power meter EPM-442A	GB37480704	09-Oct-13 (No. 217-01827)	Oct-14
Power sensor HP 8481A	US37292783	09-Oct-13 (No. 217-01827)	Oct-14
Power sensor HP 8481A	MY41092317	09-Oct-13 (No. 217-01828)	Oct-14
Reference 20 dB Attenuator	SN: 5058 (20k)	03-Apr-14 (No. 217-01918)	Apr-15
Type-N mismatch combination	SN: 5047.2 / 06327	03-Apr-14 (No. 217-01921)	Apr-15
Reference Probe ES3DV3	SN: 3205	30-Dec-13 (No. ES3-3205_Dec13)	Dec-14
DAE4	SN: 601	30-Apr-14 (No. DAE4-601_Apr14)	Apr-15
Secondary Standards	ID #	Check Date (in house)	Scheduled Check
RF generator R&S SMT-06	100005	04-Aug-99 (in house check Oct-13)	In house check: Oct-16
Network Analyzer HP 8753E	US37390585 S4206	18-Oct-01 (in house check Oct-13)	In house check: Oct-14

Calibrated by: **Name** Jeton Kastrati **Function** Laboratory Technician **Signature** *[Signature]*

Approved by: **Name** Katja Pokovic **Technical Manager** *[Signature]*

Issued: May 12, 2014

This calibration certificate shall not be reproduced except in full without written approval of the laboratory.



Accredited by the Swiss Accreditation Service (SAS)
The Swiss Accreditation Service is one of the signatories to the EA
Multilateral Agreement for the recognition of calibration certificates

Accreditation No.: **SCS 108**

Glossary:

TSL	tissue simulating liquid
ConvF	sensitivity in TSL / NORM x,y,z
N/A	not applicable or not measured

Calibration is Performed According to the Following Standards:

- a) IEEE Std 1528-2013, "IEEE Recommended Practice for Determining the Peak Spatial-Averaged Specific Absorption Rate (SAR) in the Human Head from Wireless Communications Devices: Measurement Techniques", June 2013
- b) IEC 62209-1, "Procedure to measure the Specific Absorption Rate (SAR) for hand-held devices used in close proximity to the ear (frequency range of 300 MHz to 3 GHz)", February 2005
- c) KDB 865664, "SAR Measurement Requirements for 100 MHz to 6 GHz"

Additional Documentation:

- d) DASY4/5 System Handbook

Methods Applied and Interpretation of Parameters:

- *Measurement Conditions:* Further details are available from the Validation Report at the end of the certificate. All figures stated in the certificate are valid at the frequency indicated.
- *Antenna Parameters with TSL:* The dipole is mounted with the spacer to position its feed point exactly below the center marking of the flat phantom section, with the arms oriented parallel to the body axis.
- *Feed Point Impedance and Return Loss:* These parameters are measured with the dipole positioned under the liquid filled phantom. The impedance stated is transformed from the measurement at the SMA connector to the feed point. The Return Loss ensures low reflected power. No uncertainty required.
- *Electrical Delay:* One-way delay between the SMA connector and the antenna feed point. No uncertainty required.
- *SAR measured:* SAR measured at the stated antenna input power.
- *SAR normalized:* SAR as measured, normalized to an input power of 1 W at the antenna connector.
- *SAR for nominal TSL parameters:* The measured TSL parameters are used to calculate the nominal SAR result.

The reported uncertainty of measurement is stated as the standard uncertainty of measurement multiplied by the coverage factor $k=2$, which for a normal distribution corresponds to a coverage probability of approximately 95%.

Measurement Conditions

DASY system configuration, as far as not given on page 1.

DASY Version	DASY5	V52.8.8
Extrapolation	Advanced Extrapolation	
Phantom	Modular Flat Phantom	
Distance Dipole Center - TSL	10 mm	with Spacer
Zoom Scan Resolution	dx, dy, dz = 5 mm	
Frequency	1750 MHz \pm 1 MHz	

Head TSL parameters

The following parameters and calculations were applied.

	Temperature	Permittivity	Conductivity
Nominal Head TSL parameters	22.0 °C	40.1	1.37 mho/m
Measured Head TSL parameters	(22.0 \pm 0.2) °C	39.0 \pm 6 %	1.36 mho/m \pm 6 %
Head TSL temperature change during test	< 0.5 °C	----	----

SAR result with Head TSL

SAR averaged over 1 cm ³ (1 g) of Head TSL	Condition	
SAR measured	250 mW input power	9.23 W/kg
SAR for nominal Head TSL parameters	normalized to 1W	36.9 W/kg \pm 17.0 % (k=2)

SAR averaged over 10 cm ³ (10 g) of Head TSL	condition	
SAR measured	250 mW input power	4.87 W/kg
SAR for nominal Head TSL parameters	normalized to 1W	19.5 W/kg \pm 16.5 % (k=2)

Body TSL parameters

The following parameters and calculations were applied.

	Temperature	Permittivity	Conductivity
Nominal Body TSL parameters	22.0 °C	53.4	1.49 mho/m
Measured Body TSL parameters	(22.0 \pm 0.2) °C	52.2 \pm 6 %	1.48 mho/m \pm 6 %
Body TSL temperature change during test	< 0.5 °C	----	----

SAR result with Body TSL

SAR averaged over 1 cm ³ (1 g) of Body TSL	Condition	
SAR measured	250 mW input power	9.41 W/kg
SAR for nominal Body TSL parameters	normalized to 1W	37.6 W/kg \pm 17.0 % (k=2)

SAR averaged over 10 cm ³ (10 g) of Body TSL	condition	
SAR measured	250 mW input power	5.02 W/kg
SAR for nominal Body TSL parameters	normalized to 1W	20.1 W/kg \pm 16.5 % (k=2)

Appendix

Antenna Parameters with Head TSL

Impedance, transformed to feed point	47.7 Ω - 6.1 j Ω
Return Loss	- 23.6 dB

Antenna Parameters with Body TSL

Impedance, transformed to feed point	43.7 Ω - 6.4 j Ω
Return Loss	- 20.4 dB

General Antenna Parameters and Design

Electrical Delay (one direction)	1.211 ns
----------------------------------	----------

After long term use with 100W radiated power, only a slight warming of the dipole near the feedpoint can be measured.

The dipole is made of standard semirigid coaxial cable. The center conductor of the feeding line is directly connected to the second arm of the dipole. The antenna is therefore short-circuited for DC-signals. On some of the dipoles, small end caps are added to the dipole arms in order to improve matching when loaded according to the position as explained in the "Measurement Conditions" paragraph. The SAR data are not affected by this change. The overall dipole length is still according to the Standard.

No excessive force must be applied to the dipole arms, because they might bend or the soldered connections near the feedpoint may be damaged.

Additional EUT Data

Manufactured by	SPEAG
Manufactured on	October 06, 2005

DASY5 Validation Report for Head TSL

Date: 07.05.2014

Test Laboratory: SPEAG, Zurich, Switzerland

DUT: Dipole 1765 MHz; Type: D1765V2; Serial: D1765V2 - SN: 1008

Communication System: UID 0 - CW; Frequency: 1750 MHz

Medium parameters used: $f = 1750$ MHz; $\sigma = 1.36$ S/m; $\epsilon_r = 39$; $\rho = 1000$ kg/m³

Phantom section: Flat Section

Measurement Standard: DASY5 (IEEE/IEC/ANSI C63.19-2007)

DASY52 Configuration:

- Probe: ES3DV3 - SN3205; ConvF(5.23, 5.23, 5.23); Calibrated: 30.12.2013;
- Sensor-Surface: 3mm (Mechanical Surface Detection)
- Electronics: DAE4 Sn601; Calibrated: 30.04.2014
- Phantom: Flat Phantom 5.0 (front); Type: QD000P50AA; Serial: 1001
- DASY52 52.8.8(1222); SEMCAD X 14.6.10(7331)

Dipole Calibration for Head Tissue/Pin=250 mW, d=10mm/Zoom Scan (7x7x7)/Cube 0:

Measurement grid: dx=5mm, dy=5mm, dz=5mm

Reference Value = 96.06 V/m; Power Drift = 0.01 dB

Peak SAR (extrapolated) = 16.7 W/kg

SAR(1 g) = 9.23 W/kg; SAR(10 g) = 4.87 W/kg

Maximum value of SAR (measured) = 11.7 W/kg

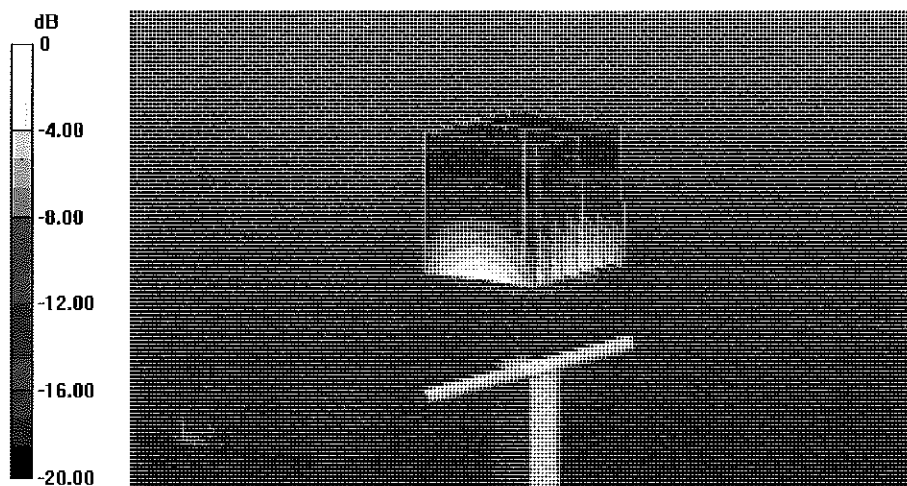

0 dB = 11.7 W/kg = 10.68 dBW/kg

Impedance Measurement Plot for Head TSL

7 May 2014 09:22:35

CH1 S11 1 U FS 1: 47.709 Ω -6.0566 Ω 15.016 pF 1 750.000 000 MHz

*
De1

CΔ

Avg
16

H1 d

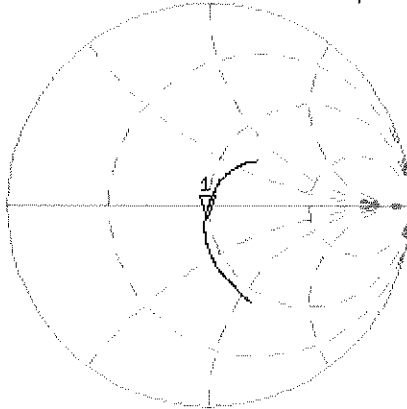

CH2 S11 LOG 5 dB/REF -20 dB 1:-23.588 dB 1 750.000 000 MHz

CΔ

Avg
16

H1 d

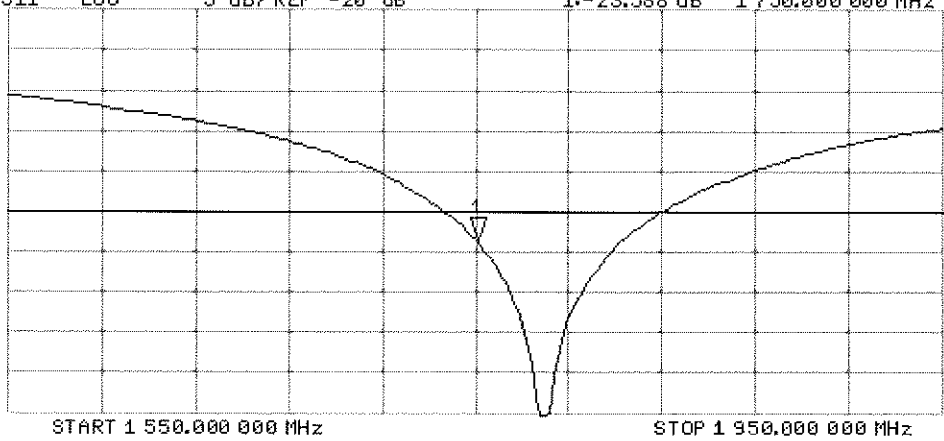

DASY5 Validation Report for Body TSL

Date: 07.05.2014

Test Laboratory: SPEAG, Zurich, Switzerland

DUT: Dipole 1765 MHz; Type: D1765V2; Serial: D1765V2 - SN: 1008

Communication System: UID 0 - CW; Frequency: 1750 MHz

Medium parameters used: $f = 1750$ MHz; $\sigma = 1.48$ S/m; $\epsilon_r = 52.2$; $\rho = 1000$ kg/m³

Phantom section: Flat Section

Measurement Standard: DASY5 (IEEE/IEC/ANSI C63.19-2007)

DASY52 Configuration:

- Probe: ES3DV3 - SN3205; ConvF(4.89, 4.89, 4.89); Calibrated: 30.12.2013;
- Sensor-Surface: 3mm (Mechanical Surface Detection)
- Electronics: DAE4 Sn601; Calibrated: 30.04.2014
- Phantom: Flat Phantom 5.0 (back); Type: QD000P50AA; Serial: 1002
- DASY52 52.8.8(1222); SEMCAD X 14.6.10(7331)

Dipole Calibration for Body Tissue/Pin=250 mW, d=10mm/Zoom Scan (7x7x7)/Cube 0:

Measurement grid: dx=5mm, dy=5mm, dz=5mm

Reference Value = 93.01 V/m; Power Drift = 0.00 dB

Peak SAR (extrapolated) = 16.3 W/kg

SAR(1 g) = 9.41 W/kg; SAR(10 g) = 5.02 W/kg

Maximum value of SAR (measured) = 11.8 W/kg

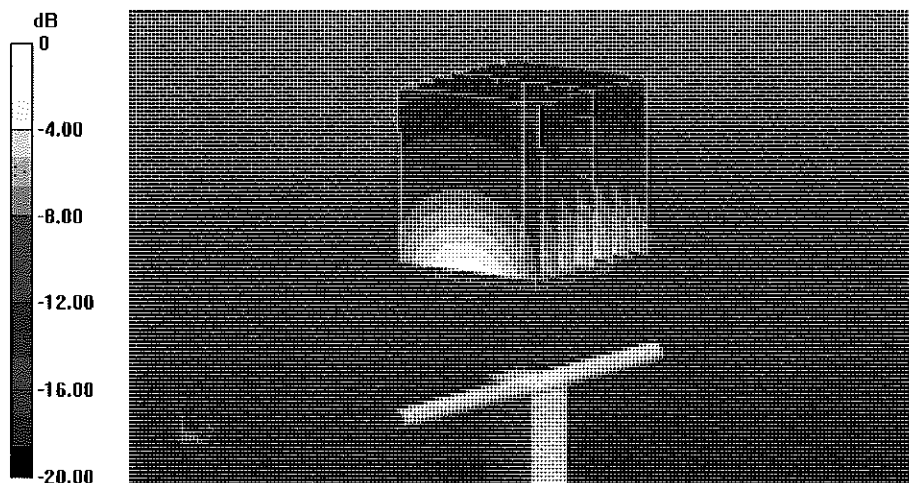

0 dB = 11.8 W/kg = 10.72 dBW/kg

Impedance Measurement Plot for Body TSL

7 May 2014 09:21:55

CH1 S11 1 U FS 1: 43.727 Ω -5.3691 Ω 14.279 pF 1 750.000 000 MHz

*
De1

CA

Avg
16

H1d

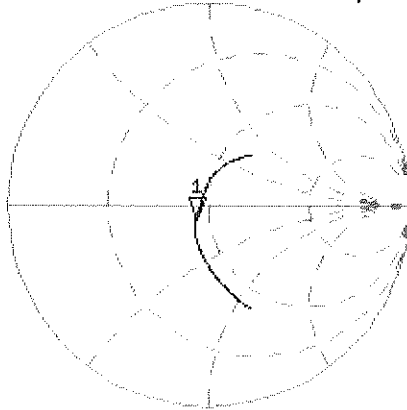

CH2 S11 LOG 5 dB/REF -20 dB 1:-20.428 dB 1 750.000 000 MHz

CA

Avg
16

H1d

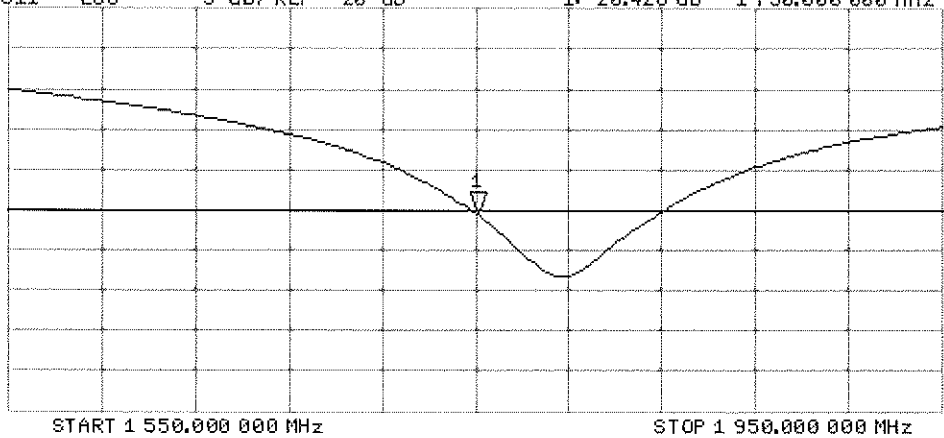



Accredited by the Swiss Accreditation Service (SAS)
The Swiss Accreditation Service is one of the signatories to the EA
Multilateral Agreement for the recognition of calibration certificates

Accreditation No.: **SCS 108**

Client **PC Test**

Certificate No: **D1900V2-5d141_Apr14**

CALIBRATION CERTIFICATE

Object **D1900V2 - SN: 5d141**

Calibration procedure(s) **QA CAL-05.v9
Calibration procedure for dipole validation kits above 700 MHz**

Calibration date: **April 09, 2014**

✓
Kok
5/7/14

This calibration certificate documents the traceability to national standards, which realize the physical units of measurements (SI).
The measurements and the uncertainties with confidence probability are given on the following pages and are part of the certificate.

All calibrations have been conducted in the closed laboratory facility: environment temperature (22 ± 3)°C and humidity < 70%.

Calibration Equipment used (M&TE critical for calibration)

Primary Standards	ID #	Cal Date (Certificate No.)	Scheduled Calibration
Power meter EPM-442A	GB37480704	09-Oct-13 (No. 217-01827)	Oct-14
Power sensor HP 8481A	US37292783	09-Oct-13 (No. 217-01827)	Oct-14
Power sensor HP 8481A	MY41092317	09-Oct-13 (No. 217-01828)	Oct-14
Reference 20 dB Attenuator	SN: 5058 (20k)	03-Apr-14 (No. 217-01918)	Apr-15
Type-N mismatch combination	SN: 5047.2 / 06327	03-Apr-14 (No. 217-01921)	Apr-15
Reference Probe ES3DV3	SN: 3205	30-Dec-13 (No. ES3-3205_Dec13)	Dec-14
DAE4	SN: 801	25-Apr-13 (No. DAE4-801_Apr13)	Apr-14

Secondary Standards	ID #	Check Date (in house)	Scheduled Check
RF generator R&S SMT-06	100005	04-Aug-99 (in house check Oct-13)	In house check: Oct-16
Network Analyzer HP 8753E	US37390585 S4206	18-Oct-01 (in house check Oct-13)	In house check: Oct-14

Calibrated by: **Claudio Leubler** Function: **Laboratory Technician**

Signature

Approved by: **Katja Pokovic** Technical Manager

Issued: April 9, 2014

This calibration certificate shall not be reproduced except in full without written approval of the laboratory.



Accredited by the Swiss Accreditation Service (SAS)
The Swiss Accreditation Service is one of the signatories to the EA
Multilateral Agreement for the recognition of calibration certificates

Accreditation No.: **SCS 108**

Glossary:

TSL	tissue simulating liquid
ConvF	sensitivity in TSL / NORM x,y,z
N/A	not applicable or not measured

Calibration is Performed According to the Following Standards:

- IEEE Std 1528-2013, "IEEE Recommended Practice for Determining the Peak Spatial-Averaged Specific Absorption Rate (SAR) in the Human Head from Wireless Communications Devices: Measurement Techniques", June 2013
- IEC 62209-1, "Procedure to measure the Specific Absorption Rate (SAR) for hand-held devices used in close proximity to the ear (frequency range of 300 MHz to 3 GHz)", February 2005
- KDB 865664, "SAR Measurement Requirements for 100 MHz to 6 GHz"

Additional Documentation:

- DASY4/5 System Handbook

Methods Applied and Interpretation of Parameters:

- Measurement Conditions:* Further details are available from the Validation Report at the end of the certificate. All figures stated in the certificate are valid at the frequency indicated.
- Antenna Parameters with TSL:* The dipole is mounted with the spacer to position its feed point exactly below the center marking of the flat phantom section, with the arms oriented parallel to the body axis.
- Feed Point Impedance and Return Loss:* These parameters are measured with the dipole positioned under the liquid filled phantom. The impedance stated is transformed from the measurement at the SMA connector to the feed point. The Return Loss ensures low reflected power. No uncertainty required.
- Electrical Delay:* One-way delay between the SMA connector and the antenna feed point. No uncertainty required.
- SAR measured:* SAR measured at the stated antenna input power.
- SAR normalized:* SAR as measured, normalized to an input power of 1 W at the antenna connector.
- SAR for nominal TSL parameters:* The measured TSL parameters are used to calculate the nominal SAR result.

The reported uncertainty of measurement is stated as the standard uncertainty of measurement multiplied by the coverage factor $k=2$, which for a normal distribution corresponds to a coverage probability of approximately 95%.

Measurement Conditions

DASY system configuration, as far as not given on page 1.

DASY Version	DASY5	V52.8.7
Extrapolation	Advanced Extrapolation	
Phantom	Modular Flat Phantom	
Distance Dipole Center - TSL	10 mm	with Spacer
Zoom Scan Resolution	dx, dy, dz = 5 mm	
Frequency	1900 MHz \pm 1 MHz	

Head TSL parameters

The following parameters and calculations were applied.

	Temperature	Permittivity	Conductivity
Nominal Head TSL parameters	22.0 °C	40.0	1.40 mho/m
Measured Head TSL parameters	(22.0 \pm 0.2) °C	39.1 \pm 6 %	1.36 mho/m \pm 6 %
Head TSL temperature change during test	< 0.5 °C	----	----

SAR result with Head TSL

SAR averaged over 1 cm ³ (1 g) of Head TSL	Condition	
SAR measured	250 mW input power	9.91 W/kg
SAR for nominal Head TSL parameters	normalized to 1W	40.1 W/kg \pm 17.0 % (k=2)

SAR averaged over 10 cm ³ (10 g) of Head TSL	condition	
SAR measured	250 mW input power	5.17 W/kg
SAR for nominal Head TSL parameters	normalized to 1W	20.8 W/kg \pm 16.5 % (k=2)

Body TSL parameters

The following parameters and calculations were applied.

	Temperature	Permittivity	Conductivity
Nominal Body TSL parameters	22.0 °C	53.3	1.52 mho/m
Measured Body TSL parameters	(22.0 \pm 0.2) °C	52.4 \pm 6 %	1.52 mho/m \pm 6 %
Body TSL temperature change during test	< 0.5 °C	----	----

SAR result with Body TSL

SAR averaged over 1 cm ³ (1 g) of Body TSL	Condition	
SAR measured	250 mW input power	10.2 W/kg
SAR for nominal Body TSL parameters	normalized to 1W	40.6 W/kg \pm 17.0 % (k=2)

SAR averaged over 10 cm ³ (10 g) of Body TSL	condition	
SAR measured	250 mW input power	5.41 W/kg
SAR for nominal Body TSL parameters	normalized to 1W	21.6 W/kg \pm 16.5 % (k=2)

Appendix

Antenna Parameters with Head TSL

Impedance, transformed to feed point	52.8 Ω + 5.5 j Ω
Return Loss	- 24.5 dB

Antenna Parameters with Body TSL

Impedance, transformed to feed point	48.8 Ω + 6.3 j Ω
Return Loss	- 23.7 dB

General Antenna Parameters and Design

Electrical Delay (one direction)	1.199 ns
----------------------------------	----------

After long term use with 100W radiated power, only a slight warming of the dipole near the feedpoint can be measured.

The dipole is made of standard semirigid coaxial cable. The center conductor of the feeding line is directly connected to the second arm of the dipole. The antenna is therefore short-circuited for DC-signals. On some of the dipoles, small end caps are added to the dipole arms in order to improve matching when loaded according to the position as explained in the "Measurement Conditions" paragraph. The SAR data are not affected by this change. The overall dipole length is still according to the Standard.

No excessive force must be applied to the dipole arms, because they might bend or the soldered connections near the feedpoint may be damaged.

Additional EUT Data

Manufactured by	SPEAG
Manufactured on	March 11, 2011

DASY5 Validation Report for Head TSL

Date: 09.04.2014

Test Laboratory: SPEAG, Zurich, Switzerland

DUT: Dipole 1900 MHz; Type: D1900V2; Serial: D1900V2 - SN: 5d141

Communication System: UID 0 - CW; Frequency: 1900 MHz

Medium parameters used: $f = 1900$ MHz; $\sigma = 1.36$ S/m; $\epsilon_r = 39.1$; $\rho = 1000$ kg/m³

Phantom section: Flat Section

Measurement Standard: DASY5 (IEEE/IEC/ANSI C63.19-2007)

DASY52 Configuration:

- Probe: ES3DV3 - SN3205; ConvF(5.06, 5.06, 5.06); Calibrated: 30.12.2013;
- Sensor-Surface: 3mm (Mechanical Surface Detection)
- Electronics: DAE4 Sn601; Calibrated: 25.04.2013
- Phantom: Flat Phantom 5.0 (front); Type: QD000P50AA; Serial: 1001
- DASY52 52.8.7(1137); SEMCAD X 14.6.10(7164)

Dipole Calibration for Head Tissue/ $P_{in}=250$ mW, $d=10$ mm/Zoom Scan (7x7x7)/Cube 0:

Measurement grid: $dx=5$ mm, $dy=5$ mm, $dz=5$ mm

Reference Value = 99.080 V/m; Power Drift = 0.01 dB

Peak SAR (extrapolated) = 18.2 W/kg

SAR(1 g) = 9.91 W/kg; SAR(10 g) = 5.17 W/kg

Maximum value of SAR (measured) = 12.5 W/kg

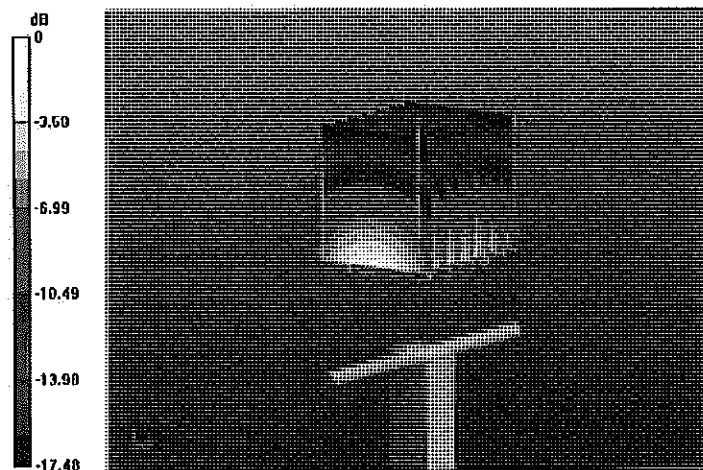

0 dB = 12.5 W/kg = 10.97 dBW/kg

Impedance Measurement Plot for Head TSL

9 Apr 2014 11:03:32

CH1 S11 1 U FS 1: 52.760 n 5.4512 n 456.62 pH 1 900.000 000 MHz

*
Del
CA

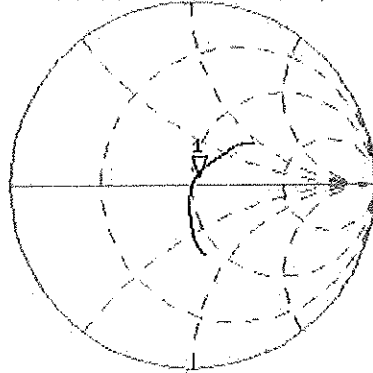

AVG
16

H1d

CH2 S11 LOG 5 dB/REF -20 dB 1: -24.525 dB 1 900.000 000 MHz

CA

AVG
16

H1d

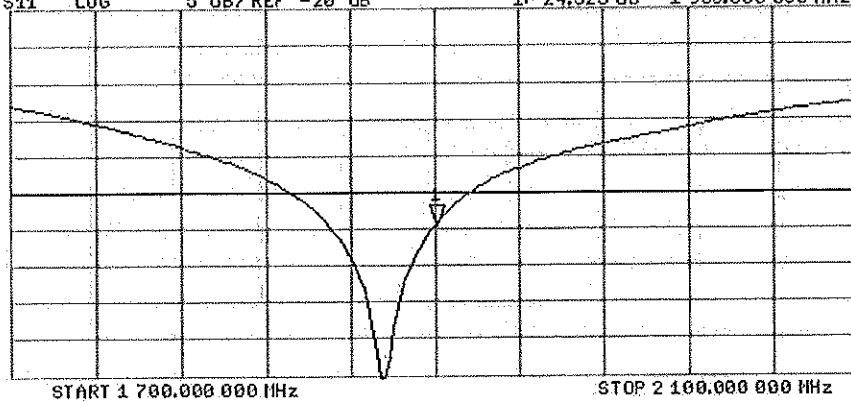

DASY5 Validation Report for Body TSL

Date: 09.04.2014

Test Laboratory: SPEAG, Zurich, Switzerland

DUT: Dipole 1900 MHz; Type: D1900V2; Serial: D1900V2 - SN: 5d141

Communication System: UID 0 - CW; Frequency: 1900 MHz

Medium parameters used: $f = 1900$ MHz; $\sigma = 1.52$ S/m; $\epsilon_r = 52.4$; $\rho = 1000$ kg/m³

Phantom section: Flat Section

Measurement Standard: DASY5 (IEEE/IEC/ANSI C63.19-2007)

DASY52 Configuration:

- Probe: ES3DV3 - SN3205; ConvF(4.76, 4.76, 4.76); Calibrated: 30.12.2013;
- Sensor-Surface: 3mm (Mechanical Surface Detection)
- Electronics: DAE4 Sn601; Calibrated: 25.04.2013
- Phantom: Flat Phantom 5.0 (back); Type: QD000P50AA; Serial: 1002
- DASY52 52.8.7(1137); SEMCAD X 14.6.10(7164)

Dipole Calibration for Body Tissue/Pin=250 mW, d=10mm/Zoom Scan (7x7x7)/Cube 0:

Measurement grid: dx=5mm, dy=5mm, dz=5mm

Reference Value = 95.820 V/m; Power Drift = -0.01 dB

Peak SAR (extrapolated) = 17.9 W/kg

SAR(1 g) = 10.2 W/kg; SAR(10 g) = 5.41 W/kg

Maximum value of SAR (measured) = 12.9 W/kg

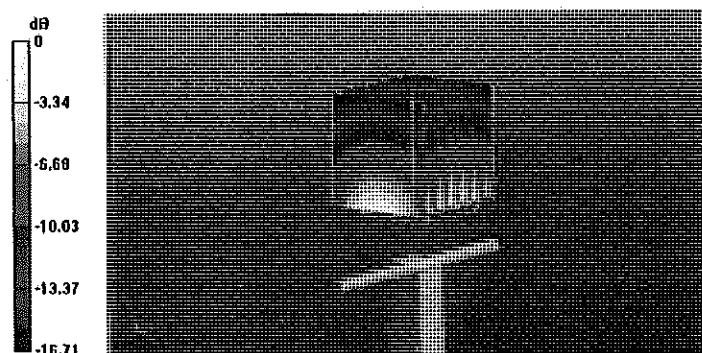

0 dB = 12.9 W/kg = 11.11 dBW/kg

Impedance Measurement Plot for Body TSL

9 Apr 2014 11:02:32

CH1 S11 1 U FS 1: 48.752 Ω 6.3320 Ω 530.41 μ H 1 900.000 000 MHz

*
Del
CA
Avg
16
↑

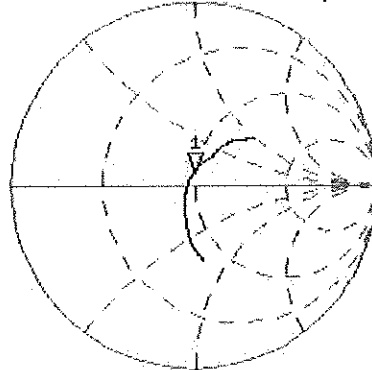

CH2 S11 LOG 5 dB/REF -20 dB 1: -23.715 dB 1 900.000 000 MHz

CA
Avg
16
↑

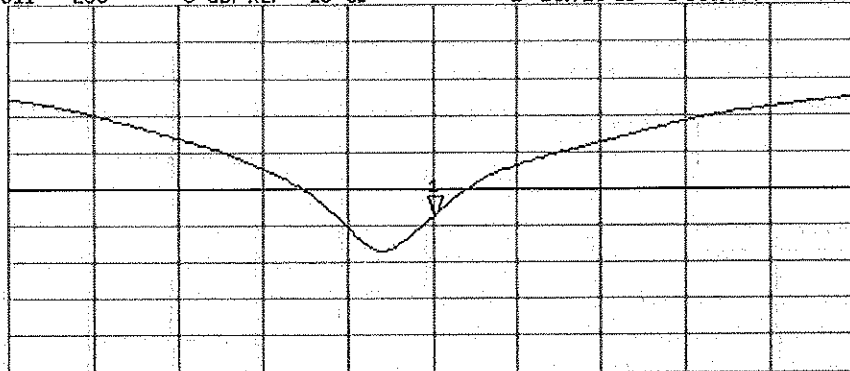

START 1 700.000 000 MHz STOP 2 100.000 000 MHz



Accredited by the Swiss Accreditation Service (SAS)
The Swiss Accreditation Service is one of the signatories to the EA
Multilateral Agreement for the recognition of calibration certificates

Accreditation No.: **SCS 108**

Client **PC Test**

Certificate No: **ES3-3258_Feb14**

CALIBRATION CERTIFICATE

Object **ES3DV3 - SN:3258**

Calibration procedure(s) **QA CAL-01.v9, QA CAL-23.v5, QA CAL-25.v6
Calibration procedure for dosimetric E-field probes** *CCV 3/16/14*

Calibration date: **February 25, 2014**

This calibration certificate documents the traceability to national standards, which realize the physical units of measurements (SI).
The measurements and the uncertainties with confidence probability are given on the following pages and are part of the certificate.

All calibrations have been conducted in the closed laboratory facility: environment temperature (22 ± 3)°C and humidity < 70%.

Calibration Equipment used (M&TE critical for calibration)

Primary Standards	ID	Cal Date (Certificate No.)	Scheduled Calibration
Power meter E4419B	GB41293874	04-Apr-13 (No. 217-01733)	Apr-14
Power sensor E4412A	MY41498087	04-Apr-13 (No. 217-01733)	Apr-14
Reference 3 dB Attenuator	SN: S5054 (3c)	04-Apr-13 (No. 217-01737)	Apr-14
Reference 20 dB Attenuator	SN: S5277 (20x)	04-Apr-13 (No. 217-01735)	Apr-14
Reference 30 dB Attenuator	SN: S5129 (30b)	04-Apr-13 (No. 217-01738)	Apr-14
Reference Probe ES3DV2	SN: 3013	30-Dec-13 (No. ES3-3013_Dec13)	Dec-14
DAE4	SN: 660	13-Dec-13 (No. DAE4-660_Dec13)	Dec-14
Secondary Standards	ID	Check Date (in house)	Scheduled Check
RF generator HP 8648C	US3642U01700	4-Aug-99 (in house check Apr-13)	In house check: Apr-16
Network Analyzer HP 8753E	US37390585	18-Oct-01 (in house check Oct-13)	In house check: Oct-14

Calibrated by:	Name Israe El-Naouq	Function Laboratory Technician	Signature <i>Israe El-Naouq</i>
Approved by:	Name Katja Pokovic	Function Technical Manager	Signature <i>Katja Pokovic</i>

Issued: February 27, 2014

This calibration certificate shall not be reproduced except in full without written approval of the laboratory.

PCT# 80615



Accredited by the Swiss Accreditation Service (SAS)

Accreditation No.: **SCS 108**

The Swiss Accreditation Service is one of the signatories to the EA Multilateral Agreement for the recognition of calibration certificates

Glossary:

TSL	tissue simulating liquid
NORM _{x,y,z}	sensitivity in free space
ConvF	sensitivity in TSL / NORM _{x,y,z}
DCP	diode compression point
CF	crest factor (1/duty_cycle) of the RF signal
A, B, C, D	modulation dependent linearization parameters
Polarization φ	φ rotation around probe axis
Polarization ϑ	ϑ rotation around an axis that is in the plane normal to probe axis (at measurement center), i.e., $\vartheta = 0$ is normal to probe axis
Connector Angle	information used in DASY system to align probe sensor X to the robot coordinate system

Calibration is Performed According to the Following Standards:

- IEEE Std 1528-2013, "IEEE Recommended Practice for Determining the Peak Spatial-Averaged Specific Absorption Rate (SAR) in the Human Head from Wireless Communications Devices: Measurement Techniques", June 2013
- IEC 62209-1, "Procedure to measure the Specific Absorption Rate (SAR) for hand-held devices used in close proximity to the ear (frequency range of 300 MHz to 3 GHz)", February 2005

Methods Applied and Interpretation of Parameters:

- NORM_{x,y,z}**: Assessed for E-field polarization $\vartheta = 0$ ($f \leq 900$ MHz in TEM-cell; $f > 1800$ MHz: R22 waveguide). NORM_{x,y,z} are only intermediate values, i.e., the uncertainties of NORM_{x,y,z} does not affect the E²-field uncertainty inside TSL (see below ConvF).
- NORM(f)_{x,y,z}** = NORM_{x,y,z} * frequency_response (see Frequency Response Chart). This linearization is implemented in DASY4 software versions later than 4.2. The uncertainty of the frequency response is included in the stated uncertainty of ConvF.
- DCP_{x,y,z}**: DCP are numerical linearization parameters assessed based on the data of power sweep with CW signal (no uncertainty required). DCP does not depend on frequency nor media.
- PAR**: PAR is the Peak to Average Ratio that is not calibrated but determined based on the signal characteristics
- A_{x,y,z}; B_{x,y,z}; C_{x,y,z}; D_{x,y,z}; VR_{x,y,z}**: A, B, C, D are numerical linearization parameters assessed based on the data of power sweep for specific modulation signal. The parameters do not depend on frequency nor media. VR is the maximum calibration range expressed in RMS voltage across the diode.
- ConvF and Boundary Effect Parameters**: Assessed in flat phantom using E-field (or Temperature Transfer Standard for $f \leq 800$ MHz) and inside waveguide using analytical field distributions based on power measurements for $f > 800$ MHz. The same setups are used for assessment of the parameters applied for boundary compensation (alpha, depth) of which typical uncertainty values are given. These parameters are used in DASY4 software to improve probe accuracy close to the boundary. The sensitivity in TSL corresponds to NORM_{x,y,z} * ConvF whereby the uncertainty corresponds to that given for ConvF. A frequency dependent ConvF is used in DASY version 4.4 and higher which allows extending the validity from ± 50 MHz to ± 100 MHz.
- Spherical isotropy (3D deviation from isotropy)**: in a field of low gradients realized using a flat phantom exposed by a patch antenna.
- Sensor Offset**: The sensor offset corresponds to the offset of virtual measurement center from the probe tip (on probe axis). No tolerance required.
- Connector Angle**: The angle is assessed using the information gained by determining the NORM_x (no uncertainty required).

Probe ES3DV3

SN:3258

Manufactured: January 25, 2010
Calibrated: February 25, 2014

Calibrated for DASY/EASY Systems
(Note: non-compatible with DASY2 system!)

DASY/EASY - Parameters of Probe: ES3DV3 - SN:3258

Basic Calibration Parameters

	Sensor X	Sensor Y	Sensor Z	Unc (k=2)
Norm ($\mu V/(V/m)^2$) ^A	1.29	1.19	1.23	± 10.1 %
DCP (mV) ^B	104.5	107.0	103.0	

Modulation Calibration Parameters

UID	Communication System Name		A dB	B dB√μV	C	D dB	VR mV	Unc ^E (k=2)
0	CW	X	0.0	0.0	1.0	0.00	222.4	±3.8 %
		Y	0.0	0.0	1.0		202.2	
		Z	0.0	0.0	1.0		207.1	
10010-CAA	SAR Validation (Square, 100ms, 10ms)	X	5.09	65.6	14.1	10.00	44.8	±1.9 %
		Y	1.68	57.4	9.3		40.7	
		Z	4.01	62.4	13.0		51.1	
10011-CAB	UMTS-FDD (WCDMA)	X	3.34	67.5	18.9	2.91	131.2	±0.5 %
		Y	3.43	67.9	18.7		137.1	
		Z	3.42	67.8	19.0		146.0	
10012-CAA	IEEE 802.11b WiFi 2.4 GHz (DSSS, 1 Mbps)	X	3.40	70.9	19.8	1.87	134.2	±0.7 %
		Y	3.19	70.2	19.2		137.9	
		Z	3.46	70.8	19.6		149.6	
10021-DAB	GSM-FDD (TDMA, GMSK)	X	30.24	99.7	28.7	9.39	131.2	±1.4 %
		Y	12.91	88.5	23.9		147.5	
		Z	30.37	99.5	28.9		128.0	
10023-DAB	GPRS-FDD (TDMA, GMSK, TN 0)	X	29.88	100.0	29.0	9.57	123.0	±1.9 %
		Y	16.02	92.5	25.4		140.7	
		Z	30.01	100.0	29.4		125.8	
10024-DAB	GPRS-FDD (TDMA, GMSK, TN 0-1)	X	44.57	99.7	25.9	6.56	119.6	±1.7 %
		Y	28.97	95.3	23.2		127.6	
		Z	43.72	99.8	26.3		120.1	
10027-DAB	GPRS-FDD (TDMA, GMSK, TN 0-1-2)	X	53.52	99.7	24.4	4.80	129.4	±2.2 %
		Y	54.55	99.9	22.9		143.3	
		Z	51.63	99.7	24.8		127.5	
10028-DAB	GPRS-FDD (TDMA, GMSK, TN 0-1-2-3)	X	58.93	99.8	23.4	3.55	133.4	±2.2 %
		Y	77.54	99.7	21.3		125.3	
		Z	56.64	99.8	23.8		130.8	
10032-CAA	IEEE 802.15.1 Bluetooth (GFSK, DH5)	X	47.03	99.5	21.3	1.16	136.3	±1.7 %
		Y	95.86	95.2	17.1		138.2	
		Z	39.68	100.0	22.2		132.3	
10039-CAB	CDMA2000 (1xRTT, RC1)	X	4.84	66.8	19.1	4.57	131.3	±0.9 %
		Y	4.75	67.0	18.9		135.2	
		Z	4.86	66.7	19.0		127.2	

10081-CAB	CDMA2000 (1xRTT, RC3)	X	4.06	66.8	19.0	3.97	148.4	±0.7 %
		Y	3.96	66.6	18.6		134.7	
		Z	4.13	66.9	19.1		143.4	
10098-CAB	UMTS-FDD (HSUPA, Subtest 2)	X	4.63	66.8	18.7	3.98	137.3	±0.7 %
		Y	4.75	67.5	18.8		148.4	
		Z	4.65	66.7	18.7		133.2	
10100-CAB	LTE-FDD (SC-FDMA, 100% RB, 20 MHz, QPSK)	X	6.66	68.5	20.3	5.67	144.0	±1.2 %
		Y	6.27	67.1	19.3		130.6	
		Z	6.62	68.2	20.1		140.5	
10108-CAB	LTE-FDD (SC-FDMA, 100% RB, 10 MHz, QPSK)	X	6.53	68.0	20.2	5.80	142.6	±1.4 %
		Y	6.17	66.8	19.3		129.2	
		Z	6.52	67.8	20.1		139.0	
10110-CAB	LTE-FDD (SC-FDMA, 100% RB, 5 MHz, QPSK)	X	6.19	67.3	19.9	5.75	137.9	±1.4 %
		Y	6.12	67.3	19.6		149.5	
		Z	6.19	67.1	19.8		136.1	
10114-CAA	IEEE 802.11n (HT Greenfield, 13.5 Mbps, BPSK)	X	10.49	69.5	21.7	8.10	132.4	±2.5 %
		Y	10.23	69.1	21.3		144.3	
		Z	10.45	69.3	21.6		129.5	
10117-CAA	IEEE 802.11n (HT Mixed, 13.5 Mbps, BPSK)	X	10.46	69.5	21.7	8.07	133.9	±2.5 %
		Y	10.26	69.2	21.3		147.4	
		Z	10.47	69.4	21.7		130.5	
10151-CAB	LTE-TDD (SC-FDMA, 50% RB, 20 MHz, QPSK)	X	11.61	77.4	26.8	9.28	118.8	±3.0 %
		Y	9.89	75.2	25.7		144.9	
		Z	12.01	77.8	26.9		119.6	
10154-CAB	LTE-FDD (SC-FDMA, 50% RB, 10 MHz, QPSK)	X	6.20	67.3	19.9	5.75	139.2	±1.2 %
		Y	5.86	66.2	19.0		128.5	
		Z	6.22	67.3	19.9		136.3	
10160-CAB	LTE-FDD (SC-FDMA, 50% RB, 15 MHz, QPSK)	X	6.63	67.8	20.1	5.82	144.1	±1.4 %
		Y	6.31	66.8	19.3		133.1	
		Z	6.66	67.7	20.0		140.9	
10169-CAB	LTE-FDD (SC-FDMA, 1 RB, 20 MHz, QPSK)	X	5.25	67.5	20.2	5.73	143.6	±1.2 %
		Y	4.92	66.7	19.5		131.0	
		Z	5.29	67.4	20.2		140.7	
10172-CAB	LTE-TDD (SC-FDMA, 1 RB, 20 MHz, QPSK)	X	13.49	87.5	31.6	9.21	139.0	±2.7 %
		Y	7.83	75.5	26.0		124.9	
		Z	13.47	86.5	31.1		137.8	
10175-CAB	LTE-FDD (SC-FDMA, 1 RB, 10 MHz, QPSK)	X	5.22	67.4	20.1	5.72	144.3	±1.4 %
		Y	5.08	67.5	19.9		147.9	
		Z	5.26	67.2	20.0		139.6	
10181-CAB	LTE-FDD (SC-FDMA, 1 RB, 15 MHz, QPSK)	X	5.24	67.5	20.1	5.72	144.5	±1.2 %
		Y	5.06	67.4	19.8		147.0	
		Z	5.29	67.3	20.1		139.2	

10193-CAA	IEEE 802.11n (HT Greenfield, 6.5 Mbps, BPSK)	X	10.12	69.1	21.6	8.09	128.8	±2.2 %
		Y	9.76	68.4	21.0		132.8	
		Z	10.08	68.9	21.5		123.4	
10196-CAA	IEEE 802.11n (HT Mixed, 6.5 Mbps, BPSK)	X	10.15	69.2	21.7	8.10	130.2	±2.2 %
		Y	9.77	68.5	21.0		134.1	
		Z	10.10	69.0	21.5		124.0	
10219-CAA	IEEE 802.11n (HT Mixed, 7.2 Mbps, BPSK)	X	10.02	69.0	21.5	8.03	128.7	±2.2 %
		Y	9.67	68.5	21.0		133.3	
		Z	10.02	68.9	21.5		123.9	
10222-CAA	IEEE 802.11n (HT Mixed, 15 Mbps, BPSK)	X	10.46	69.6	21.7	8.06	134.0	±2.2 %
		Y	10.09	68.8	21.1		139.7	
		Z	10.40	69.3	21.6		128.7	
10225-CAB	UMTS-FDD (HSPA+)	X	7.09	67.1	19.6	5.97	131.2	±1.4 %
		Y	6.98	67.2	19.4		138.0	
		Z	7.06	66.8	19.4		127.2	
10237-CAB	LTE-TDD (SC-FDMA, 1 RB, 10 MHz, QPSK)	X	13.63	87.8	31.7	9.21	141.6	±3.0 %
		Y	7.85	75.5	26.0		126.5	
		Z	13.99	87.7	31.6		141.4	
10252-CAB	LTE-TDD (SC-FDMA, 50% RB, 10 MHz, QPSK)	X	12.86	81.4	28.9	9.24	142.1	±3.0 %
		Y	8.91	73.4	24.8		129.9	
		Z	13.15	81.4	28.8		142.0	
10267-CAB	LTE-TDD (SC-FDMA, 100% RB, 10 MHz, QPSK)	X	11.63	77.5	26.8	9.30	118.7	±3.0 %
		Y	9.62	74.3	25.2		138.4	
		Z	11.96	77.7	26.9		119.3	
10274-CAB	UMTS-FDD (HSUPA, Subtest 5, 3GPP Rel8.10)	X	6.14	67.4	19.3	4.87	149.9	±0.9 %
		Y	5.90	66.9	18.7		132.8	
		Z	6.20	67.5	19.3		146.6	
10275-CAB	UMTS-FDD (HSUPA, Subtest 5, 3GPP Rel8.4)	X	4.45	66.9	18.9	3.96	130.1	±0.7 %
		Y	4.50	67.2	18.8		137.9	
		Z	4.64	67.6	19.3		149.2	
10291-AAB	CDMA2000, RC3, SO55, Full Rate	X	3.79	67.5	19.2	3.46	145.3	±0.7 %
		Y	3.74	67.5	18.9		128.2	
		Z	3.78	67.3	19.1		139.1	
10292-AAB	CDMA2000, RC3, SO32, Full Rate	X	3.77	67.8	19.3	3.39	147.0	±0.5 %
		Y	3.69	67.7	18.9		130.1	
		Z	3.73	67.3	19.0		141.3	
10297-AAA	LTE-FDD (SC-FDMA, 50% RB, 20 MHz, QPSK)	X	6.52	67.9	20.1	5.81	141.4	±1.4 %
		Y	6.41	67.6	19.7		147.4	
		Z	6.51	67.7	20.1		135.4	
10311-AAA	LTE-FDD (SC-FDMA, 100% RB, 15 MHz, QPSK)	X	7.17	68.7	20.7	6.06	147.7	±1.4 %
		Y	6.69	67.2	19.6		128.6	
		Z	7.12	68.4	20.5		142.0	

10315-AAA	IEEE 802.11b WiFi 2.4 GHz (DSSS, 1 Mbps, 96pc duty cycle)	X	3.04	70.0	19.6	1.71	129.8	±0.5 %
		Y	3.25	71.3	19.7		136.9	
		Z	3.09	69.9	19.5		148.7	
10403-AAB	CDMA2000 (1xEV-DO, Rev. 0)	X	4.73	67.3	18.6	3.76	135.7	±0.5 %
		Y	4.93	69.1	19.0		141.5	
		Z	4.73	67.1	18.4		132.7	
10404-AAB	CDMA2000 (1xEV-DO, Rev. A)	X	4.67	67.5	18.6	3.77	134.0	±0.5 %
		Y	4.92	69.4	19.1		139.8	
		Z	4.65	67.1	18.5		130.7	

The reported uncertainty of measurement is stated as the standard uncertainty of measurement multiplied by the coverage factor k=2, which for a normal distribution corresponds to a coverage probability of approximately 95%.

^A The uncertainties of NormX,Y,Z do not affect the E²-field uncertainty inside TSL (see Pages 8 and 9).
^B Numerical linearization parameter: uncertainty not required.
^E Uncertainty is determined using the max. deviation from linear response applying rectangular distribution and is expressed for the square of the field value.

DASY/EASY - Parameters of Probe: ES3DV3 - SN:3258

Calibration Parameter Determined in Head Tissue Simulating Media

f (MHz) ^C	Relative Permittivity ^F	Conductivity (S/m) ^F	ConvF X	ConvF Y	ConvF Z	Alpha ^G	Depth ^G (mm)	Unct. (k=2)
750	41.9	0.89	6.53	6.53	6.53	0.40	1.60	± 12.0 %
835	41.5	0.90	6.27	6.27	6.27	0.80	1.17	± 12.0 %
1750	40.1	1.37	5.19	5.19	5.19	0.80	1.10	± 12.0 %
1900	40.0	1.40	5.04	5.04	5.04	0.68	1.27	± 12.0 %
2450	39.2	1.80	4.52	4.52	4.52	0.78	1.23	± 12.0 %
2600	39.0	1.96	4.34	4.34	4.34	0.76	1.33	± 12.0 %

^C Frequency validity of ± 100 MHz only applies for DASY v4.4 and higher (see Page 2), else it is restricted to ± 50 MHz. The uncertainty is the RSS of the ConvF uncertainty at calibration frequency and the uncertainty for the indicated frequency band.

^F At frequencies below 3 GHz, the validity of tissue parameters (ϵ and σ) can be relaxed to ± 10% if liquid compensation formula is applied to measured SAR values. At frequencies above 3 GHz, the validity of tissue parameters (ϵ and σ) is restricted to ± 5%. The uncertainty is the RSS of the ConvF uncertainty for indicated target tissue parameters.

^G Alpha/Depth are determined during calibration. SPEAG warrants that the remaining deviation due to the boundary effect after compensation is always less than ± 1% for frequencies below 3 GHz and below ± 2% for frequencies between 3-6 GHz at any distance larger than half the probe tip diameter from the boundary.

DASY/EASY - Parameters of Probe: ES3DV3 - SN:3258

Calibration Parameter Determined in Body Tissue Simulating Media

f (MHz) ^c	Relative Permittivity ^F	Conductivity (S/m) ^F	ConvF X	ConvF Y	ConvF Z	Alpha ^G	Depth ^G (mm)	Unct. (k=2)
750	55.5	0.96	6.15	6.15	6.15	0.61	1.32	± 12.0 %
835	55.2	0.97	6.11	6.11	6.11	0.80	1.15	± 12.0 %
1750	53.4	1.49	4.83	4.83	4.83	0.47	1.74	± 12.0 %
1900	53.3	1.52	4.61	4.61	4.61	0.55	1.59	± 12.0 %
2450	52.7	1.95	4.14	4.14	4.14	0.80	1.11	± 12.0 %
2600	52.5	2.16	3.91	3.91	3.91	0.80	1.00	± 12.0 %

^c Frequency validity of ± 100 MHz only applies for DASY v4.4 and higher (see Page 2), else it is restricted to ± 50 MHz. The uncertainty is the RSS of the ConvF uncertainty at calibration frequency and the uncertainty for the indicated frequency band.

^F At frequencies below 3 GHz, the validity of tissue parameters (ϵ and σ) can be relaxed to ± 10% if liquid compensation formula is applied to measured SAR values. At frequencies above 3 GHz, the validity of tissue parameters (ϵ and σ) is restricted to ± 5%. The uncertainty is the RSS of the ConvF uncertainty for indicated target tissue parameters.

^G Alpha/Depth are determined during calibration. SPEAG warrants that the remaining deviation due to the boundary effect after compensation is always less than ± 1% for frequencies below 3 GHz and below ± 2% for frequencies between 3-6 GHz at any distance larger than half the probe tip diameter from the boundary.

Frequency Response of E-Field (TEM-Cell: ifi110 EXX, Waveguide: R22)

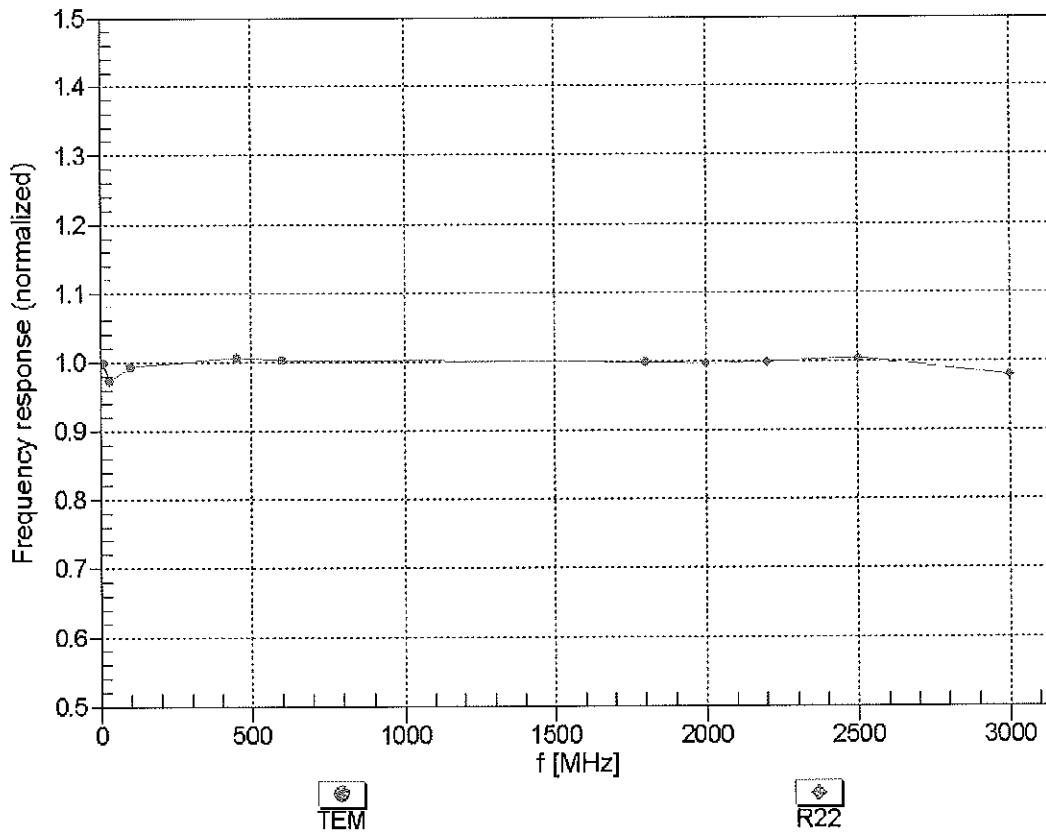

Uncertainty of Frequency Response of E-field: $\pm 6.3\%$ (k=2)

Receiving Pattern (ϕ), $\theta = 0^\circ$

f=600 MHz,TEM

f=1800 MHz,R22

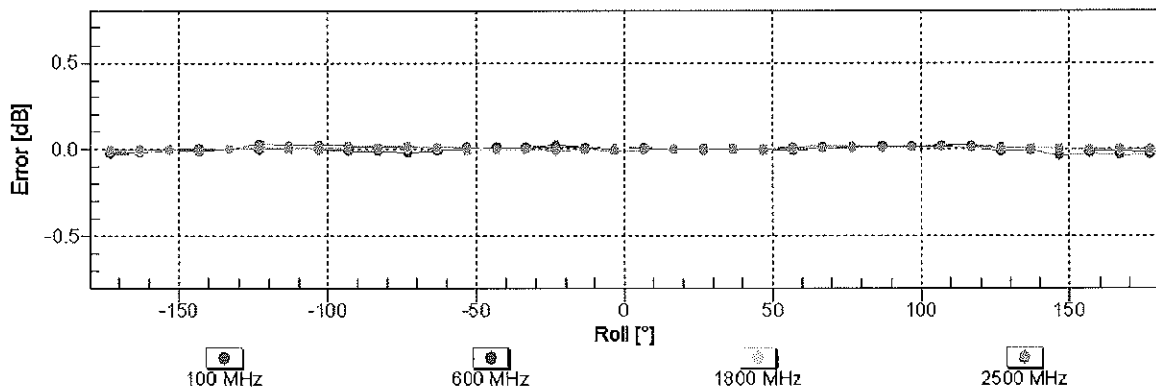
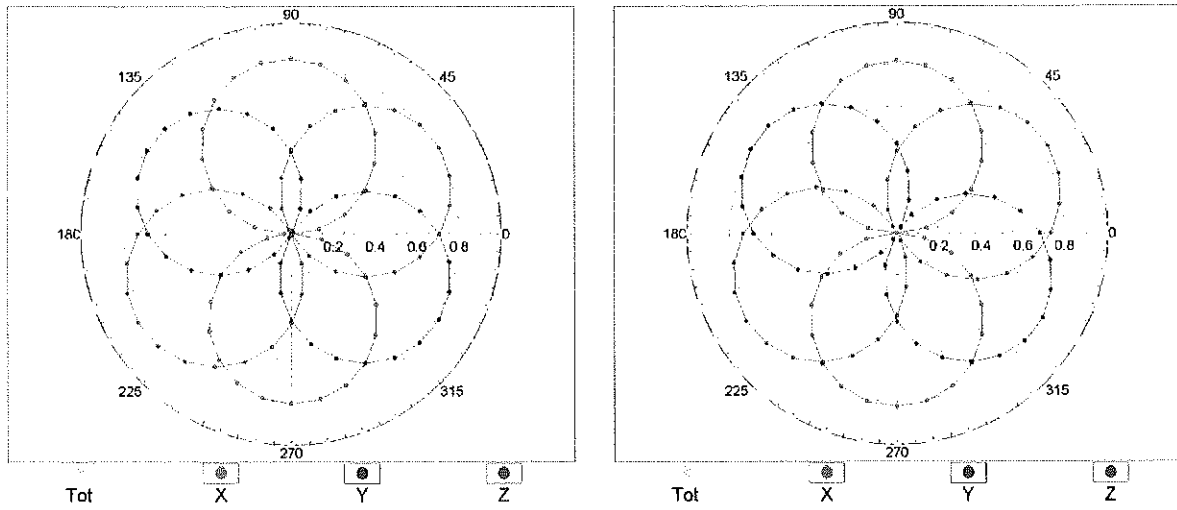

Uncertainty of Axial Isotropy Assessment: $\pm 0.5\%$ ($k=2$)

Dynamic Range f(SAR_{head}) (TEM cell , f_{eval}= 1900 MHz)

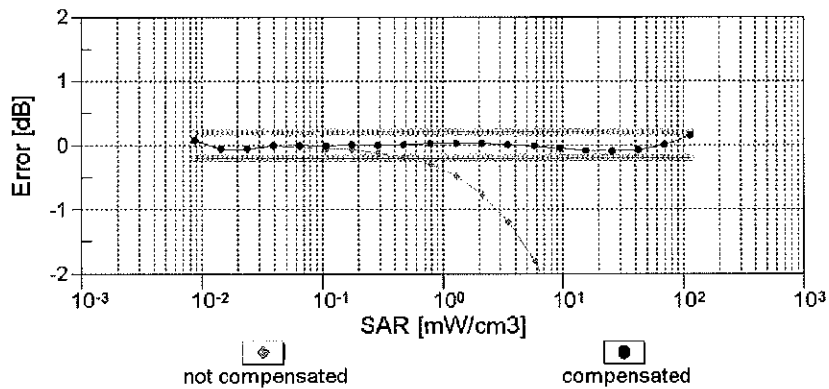
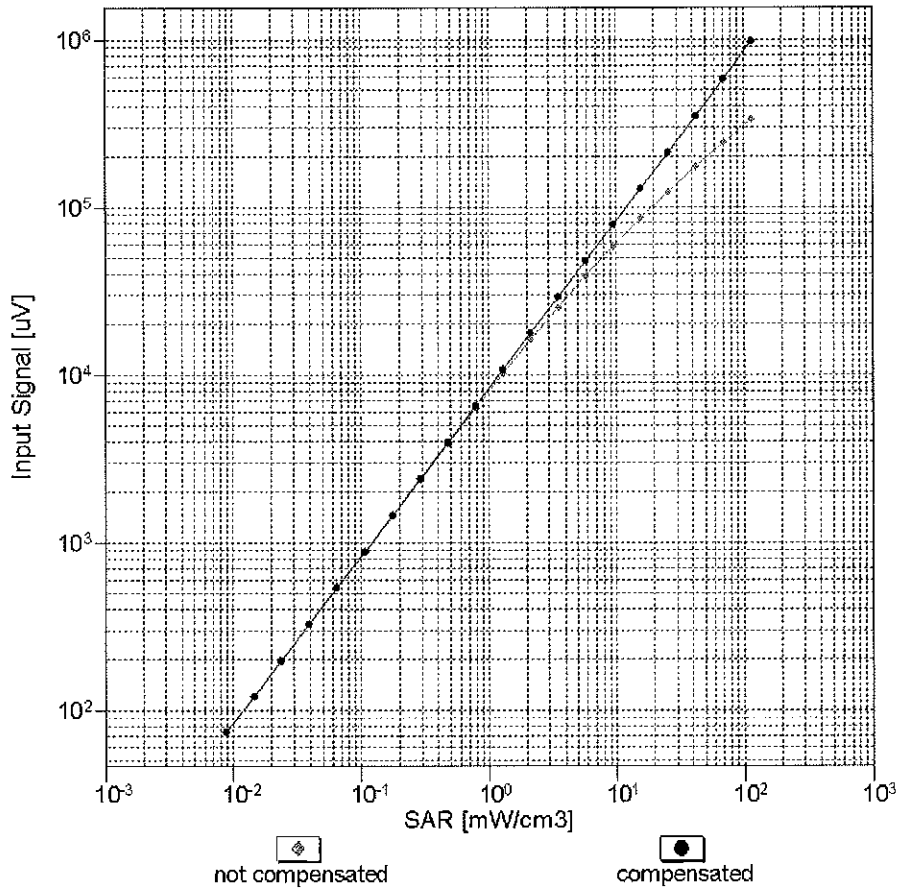

Uncertainty of Linearity Assessment: ± 0.6% (k=2)

Conversion Factor Assessment

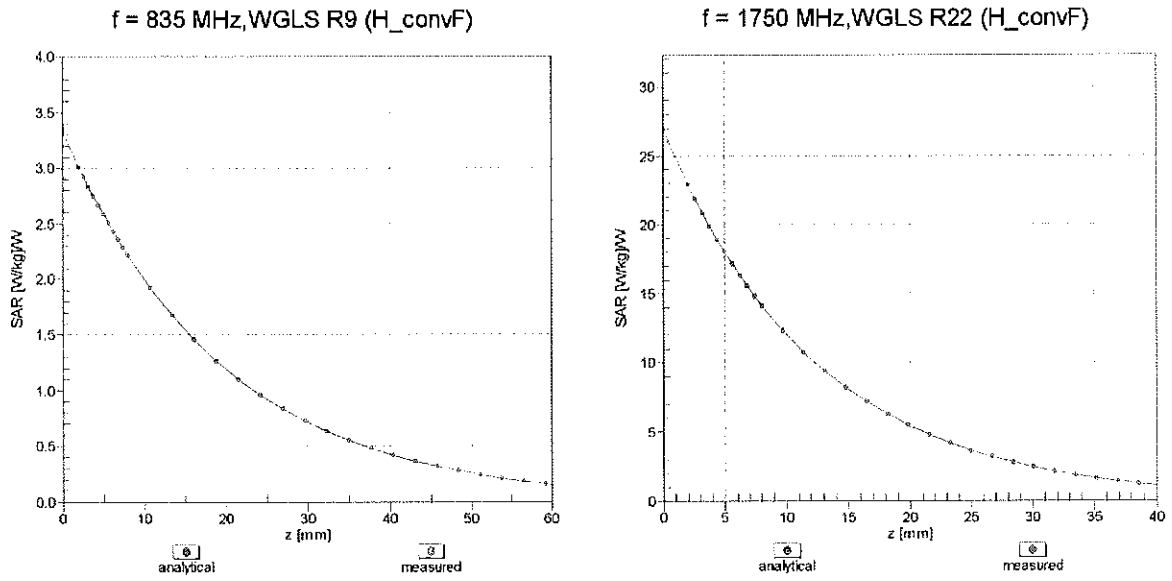

Deviation from Isotropy in Liquid Error (ϕ, ϑ), f = 900 MHz

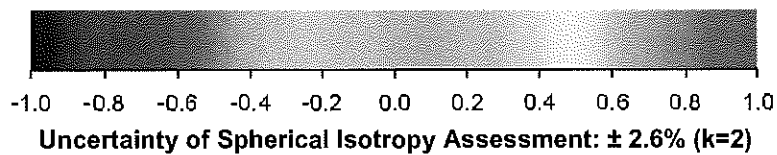
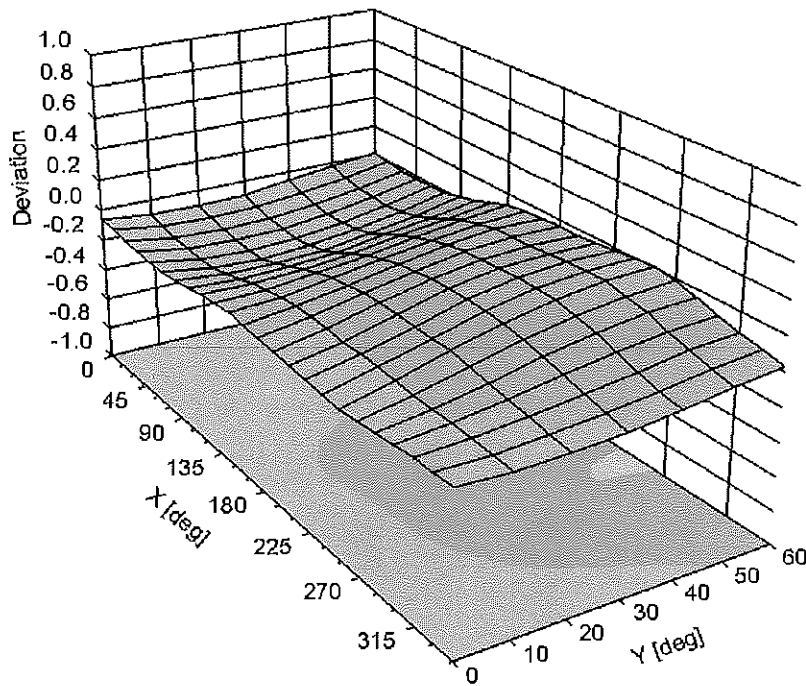

DASY/EASY - Parameters of Probe: ES3DV3 - SN:3258

Other Probe Parameters

Sensor Arrangement	Triangular
Connector Angle (°)	-123.1
Mechanical Surface Detection Mode	enabled
Optical Surface Detection Mode	disabled
Probe Overall Length	337 mm
Probe Body Diameter	10 mm
Tip Length	10 mm
Tip Diameter	4 mm
Probe Tip to Sensor X Calibration Point	2 mm
Probe Tip to Sensor Y Calibration Point	2 mm
Probe Tip to Sensor Z Calibration Point	2 mm
Recommended Measurement Distance from Surface	3 mm

**Calibration Laboratory of
Schmid & Partner
Engineering AG**
Zeughausstrasse 43, 8004 Zurich, Switzerland



S Schweizerischer Kalibrierdienst
S Service suisse d'étalonnage
S Servizio svizzero di taratura
S Swiss Calibration Service

Accredited by the Swiss Accreditation Service (SAS)
The Swiss Accreditation Service is one of the signatories to the EA
Multilateral Agreement for the recognition of calibration certificates

Accreditation No.: **SCS 108**

Client **PC Test**

Certificate No: **ES3-3288_Sep14/2**

CALIBRATION CERTIFICATE (Replacement of No:ES3-3288_Sep14)

Object **ES3DV3 - SN:3288**

Calibration procedure(s) **QA CAL-01.v9, QA CAL-23.v5, QA CAL-25.v6
Calibration procedure for dosimetric E-field probes** CC
11/12/14

Calibration date: **September 24, 2014**

This calibration certificate documents the traceability to national standards, which realize the physical units of measurements (SI).
The measurements and the uncertainties with confidence probability are given on the following pages and are part of the certificate.

All calibrations have been conducted in the closed laboratory facility: environment temperature (22 ± 3)°C and humidity < 70%.

Calibration Equipment used (M&TE critical for calibration)

Primary Standards	ID	Cal Date (Certificate No.)	Scheduled Calibration
Power meter E4419B	GB41293874	03-Apr-14 (No. 217-01911)	Apr-15
Power sensor E4412A	MY41498087	03-Apr-14 (No. 217-01911)	Apr-15
Reference 3 dB Attenuator	SN: S5054 (3c)	03-Apr-14 (No. 217-01915)	Apr-15
Reference 20 dB Attenuator	SN: S5277 (20x)	03-Apr-14 (No. 217-01919)	Apr-15
Reference 30 dB Attenuator	SN: S5129 (30b)	03-Apr-14 (No. 217-01920)	Apr-15
Reference Probe ES3DV2	SN: 3013	30-Dec-13 (No. ES3-3013_Dec13)	Dec-14
DAE4	SN: 660	13-Dec-13 (No. DAE4-660_Dec13)	Dec-14
Secondary Standards	ID	Check Date (in house)	Scheduled Check
RF generator HP 8648C	US3642U01700	4-Aug-99 (in house check Apr-13)	In house check: Apr-16
Network Analyzer HP 8753E	US37390585	18-Oct-01 (in house check Oct-13)	In house check: Oct-14

	Name	Function	Signature
Calibrated by:	Leif Klysner	Laboratory Technician	
Approved by:	Katja Pokovic	Technical Manager	

Issued: November 3, 2014

This calibration certificate shall not be reproduced except in full without written approval of the laboratory.



Accredited by the Swiss Accreditation Service (SAS)
The Swiss Accreditation Service is one of the signatories to the EA
Multilateral Agreement for the recognition of calibration certificates

Accreditation No.: **SCS 108**

Glossary:

TSL	tissue simulating liquid
NORM _{x,y,z}	sensitivity in free space
ConvF	sensitivity in TSL / NORM _{x,y,z}
DCP	diode compression point
CF	crest factor (1/duty_cycle) of the RF signal
A, B, C, D	modulation dependent linearization parameters
Polarization φ	φ rotation around probe axis
Polarization ϑ	ϑ rotation around an axis that is in the plane normal to probe axis (at measurement center), i.e., ϑ = 0 is normal to probe axis
Connector Angle	information used in DASY system to align probe sensor X to the robot coordinate system

Calibration is Performed According to the Following Standards:

- a) IEEE Std 1528-2013, "IEEE Recommended Practice for Determining the Peak Spatial-Averaged Specific Absorption Rate (SAR) in the Human Head from Wireless Communications Devices: Measurement Techniques", June 2013
- b) IEC 62209-1, "Procedure to measure the Specific Absorption Rate (SAR) for hand-held devices used in close proximity to the ear (frequency range of 300 MHz to 3 GHz)", February 2005

Methods Applied and Interpretation of Parameters:

- *NORM_{x,y,z}*: Assessed for E-field polarization ϑ = 0 (f ≤ 900 MHz in TEM-cell; f > 1800 MHz: R22 waveguide). *NORM_{x,y,z}* are only intermediate values, i.e., the uncertainties of *NORM_{x,y,z}* does not affect the E²-field uncertainty inside TSL (see below *ConvF*).
- *NORM(f)_{x,y,z}* = *NORM_{x,y,z}* * *frequency_response* (see Frequency Response Chart). This linearization is implemented in DASY4 software versions later than 4.2. The uncertainty of the frequency response is included in the stated uncertainty of *ConvF*.
- *DCP_{x,y,z}*: DCP are numerical linearization parameters assessed based on the data of power sweep with CW signal (no uncertainty required). DCP does not depend on frequency nor media.
- *PAR*: PAR is the Peak to Average Ratio that is not calibrated but determined based on the signal characteristics
- *A_{x,y,z}*; *B_{x,y,z}*; *C_{x,y,z}*; *D_{x,y,z}*; *VR_{x,y,z}*; *A, B, C, D* are numerical linearization parameters assessed based on the data of power sweep for specific modulation signal. The parameters do not depend on frequency nor media. *VR* is the maximum calibration range expressed in RMS voltage across the diode.
- *ConvF and Boundary Effect Parameters*: Assessed in flat phantom using E-field (or Temperature Transfer Standard for f ≤ 800 MHz) and inside waveguide using analytical field distributions based on power measurements for f > 800 MHz. The same setups are used for assessment of the parameters applied for boundary compensation (alpha, depth) of which typical uncertainty values are given. These parameters are used in DASY4 software to improve probe accuracy close to the boundary. The sensitivity in TSL corresponds to *NORM_{x,y,z}* * *ConvF* whereby the uncertainty corresponds to that given for *ConvF*. A frequency dependent *ConvF* is used in DASY version 4.4 and higher which allows extending the validity from ± 50 MHz to ± 100 MHz.
- *Spherical isotropy (3D deviation from isotropy)*: in a field of low gradients realized using a flat phantom exposed by a patch antenna.
- *Sensor Offset*: The sensor offset corresponds to the offset of virtual measurement center from the probe tip (on probe axis). No tolerance required.
- *Connector Angle*: The angle is assessed using the information gained by determining the *NORM_x* (no uncertainty required).

Probe ES3DV3

SN:3288

Manufactured:	July 6, 2010
Repaired:	September 18, 2014
Calibrated:	September 24, 2014

Calibrated for DASY/EASY Systems
(Note: non-compatible with DASY2 system!)

DASY/EASY - Parameters of Probe: ES3DV3 - SN:3288

Basic Calibration Parameters

	Sensor X	Sensor Y	Sensor Z	Unc (k=2)
Norm ($\mu\text{V}/(\text{V}/\text{m})^2$) ^A	1.05	1.16	0.92	$\pm 10.1 \%$
DCP (mV) ^B	105.1	104.6	106.7	

Modulation Calibration Parameters

UID	Communication System Name		A dB	B dB $\sqrt{\mu\text{V}}$	C	D dB	VR mV	Unc ^E (k=2)
0	CW	X	0.0	0.0	1.0	0.00	195.8	$\pm 3.5 \%$
		Y	0.0	0.0	1.0		175.9	
		Z	0.0	0.0	1.0		177.1	
10010-CAA	SAR Validation (Square, 100ms, 10ms)	X	2.71	61.9	11.4	10.00	40.3	$\pm 2.2 \%$
		Y	2.37	60.2	11.2		42.6	
		Z	1.54	56.6	8.9		41.2	
10011-CAB	UMTS-FDD (WCDMA)	X	3.29	67.1	18.4	2.91	133.8	$\pm 0.5 \%$
		Y	3.43	67.9	18.9		139.5	
		Z	3.45	68.1	18.9		141.3	
10012-CAA	IEEE 802.11b WiFi 2.4 GHz (DSSS, 1 Mbps)	X	2.99	68.9	18.6	1.87	135.1	$\pm 0.7 \%$
		Y	3.59	72.4	20.4		140.7	
		Z	3.54	72.4	20.3		143.0	
10013-CAA	IEEE 802.11g WiFi 2.4 GHz (DSSS-OFDM, 6 Mbps)	X	11.15	70.8	23.3	9.46	132.3	$\pm 3.5 \%$
		Y	11.29	70.8	23.2		141.1	
		Z	11.07	70.7	23.2		139.2	
10021-DAB	GSM-FDD (TDMA, GMSK)	X	14.71	90.5	24.5	9.39	149.0	$\pm 1.9 \%$
		Y	16.40	92.8	26.0		131.3	
		Z	11.34	87.2	23.6		126.1	
10023-DAB	GPRS-FDD (TDMA, GMSK, TN 0)	X	15.91	92.2	25.3	9.57	138.9	$\pm 2.5 \%$
		Y	21.25	96.9	27.2		142.0	
		Z	11.68	87.2	23.5		145.9	
10024-DAB	GPRS-FDD (TDMA, GMSK, TN 0-1)	X	38.62	99.8	24.7	6.56	123.8	$\pm 2.2 \%$
		Y	36.71	99.7	25.2		128.1	
		Z	36.56	99.4	24.5		129.5	
10027-DAB	GPRS-FDD (TDMA, GMSK, TN 0-1-2)	X	56.60	99.6	22.6	4.80	138.8	$\pm 1.9 \%$
		Y	46.94	99.9	23.7		149.9	
		Z	51.17	99.8	22.9		144.9	
10028-DAB	GPRS-FDD (TDMA, GMSK, TN 0-1-2-3)	X	70.88	100.0	21.6	3.55	147.5	$\pm 1.9 \%$
		Y	52.58	99.8	22.6		129.4	
		Z	76.98	99.8	21.2		128.7	
10032-CAA	IEEE 802.15.1 Bluetooth (GFSK, DH5)	X	98.89	99.5	18.9	1.16	135.8	$\pm 1.4 \%$
		Y	78.39	99.6	19.5		141.7	
		Z	95.21	95.5	17.1		143.4	
10039-CAB	CDMA2000 (1xRTT, RC1)	X	4.72	66.7	18.9	4.57	133.7	$\pm 0.9 \%$
		Y	4.85	67.1	19.1		137.7	
		Z	4.81	67.4	19.2		141.9	

10081-CAB	CDMA2000 (1xRTT, RC3)	X	3.91	66.3	18.6	3.97	129.5	±0.7 %
		Y	4.00	66.6	18.7		133.7	
		Z	3.99	66.8	18.8		137.5	
10098-CAB	UMTS-FDD (HSUPA, Subtest 2)	X	4.63	66.9	18.7	3.98	141.4	±0.7 %
		Y	4.78	67.5	19.0		147.7	
		Z	4.57	66.8	18.6		127.8	
10100-CAB	LTE-FDD (SC-FDMA, 100% RB, 20 MHz, QPSK)	X	6.59	68.2	20.1	5.67	149.2	±1.4 %
		Y	6.36	67.3	19.6		130.7	
		Z	6.36	67.5	19.6		133.6	
10108-CAB	LTE-FDD (SC-FDMA, 100% RB, 10 MHz, QPSK)	X	6.44	67.8	20.0	5.80	146.6	±1.4 %
		Y	6.23	66.8	19.4		128.8	
		Z	6.24	67.1	19.6		131.4	
10110-CAB	LTE-FDD (SC-FDMA, 100% RB, 5 MHz, QPSK)	X	6.08	67.1	19.6	5.75	143.2	±1.4 %
		Y	6.20	67.4	19.8		148.0	
		Z	5.92	66.6	19.3		128.5	
10114-CAA	IEEE 802.11n (HT Greenfield, 13.5 Mbps, BPSK)	X	10.32	69.3	21.5	8.10	137.0	±2.2 %
		Y	10.31	69.1	21.4		143.5	
		Z	10.37	69.5	21.6		146.1	
10117-CAA	IEEE 802.11n (HT Mixed, 13.5 Mbps, BPSK)	X	10.35	69.4	21.6	8.07	138.3	±2.2 %
		Y	10.36	69.3	21.4		146.4	
		Z	10.42	69.6	21.6		149.0	
10151-CAB	LTE-TDD (SC-FDMA, 50% RB, 20 MHz, QPSK)	X	9.95	75.7	26.2	9.28	134.9	±3.3 %
		Y	10.37	76.0	26.1		146.6	
		Z	9.77	75.4	26.0		142.5	
10154-CAB	LTE-FDD (SC-FDMA, 50% RB, 10 MHz, QPSK)	X	6.12	67.2	19.7	5.75	144.9	±1.4 %
		Y	6.21	67.4	19.8		148.8	
		Z	5.91	66.5	19.3		128.7	
10160-CAB	LTE-FDD (SC-FDMA, 50% RB, 15 MHz, QPSK)	X	6.28	66.7	19.4	5.82	125.5	±1.2 %
		Y	6.37	66.8	19.4		129.7	
		Z	6.36	67.1	19.6		132.9	
10169-CAB	LTE-FDD (SC-FDMA, 1 RB, 20 MHz, QPSK)	X	5.08	67.6	20.2	5.73	147.0	±1.2 %
		Y	4.95	66.6	19.6		128.6	
		Z	4.91	66.9	19.8		131.2	
10172-CAB	LTE-TDD (SC-FDMA, 1 RB, 20 MHz, QPSK)	X	8.18	77.2	27.2	9.21	123.4	±2.7 %
		Y	8.37	76.6	26.6		129.5	
		Z	7.97	76.7	26.9		128.7	
10175-CAB	LTE-FDD (SC-FDMA, 1 RB, 10 MHz, QPSK)	X	5.05	67.4	20.1	5.72	146.2	±1.4 %
		Y	5.10	67.3	20.0		142.8	
		Z	4.87	66.7	19.6		129.6	
10181-CAB	LTE-FDD (SC-FDMA, 1 RB, 15 MHz, QPSK)	X	5.04	67.4	20.0	5.72	145.5	±1.2 %
		Y	5.12	67.4	20.0		143.4	
		Z	4.87	66.7	19.6		129.9	
10193-CAA	IEEE 802.11n (HT Greenfield, 6.5 Mbps, BPSK)	X	9.92	68.9	21.4	8.09	131.0	±2.2 %
		Y	9.84	68.5	21.1		130.0	
		Z	9.94	69.0	21.4		138.6	

10196-CAA	IEEE 802.11n (HT Mixed, 6.5 Mbps, BPSK)	X	9.90	68.9	21.4	8.10	130.8	±2.2 %
		Y	9.81	68.4	21.0		131.4	
		Z	9.95	69.1	21.5		140.5	
10219-CAA	IEEE 802.11n (HT Mixed, 7.2 Mbps, BPSK)	X	9.81	68.8	21.3	8.03	130.0	±2.2 %
		Y	9.89	68.9	21.3		138.1	
		Z	9.89	69.1	21.5		140.5	
10222-CAA	IEEE 802.11n (HT Mixed, 15 Mbps, BPSK)	X	10.25	69.2	21.4	8.06	137.1	±2.2 %
		Y	10.30	69.2	21.4		144.4	
		Z	10.38	69.6	21.6		148.4	
10225-CAB	UMTS-FDD (HSPA+)	X	6.90	66.8	19.3	5.97	132.8	±1.4 %
		Y	7.09	67.3	19.6		142.0	
		Z	7.04	67.4	19.6		143.5	
10237-CAB	LTE-TDD (SC-FDMA, 1 RB, 10 MHz, QPSK)	X	9.61	81.9	29.6	9.21	149.3	±2.7 %
		Y	8.66	77.6	27.1		133.7	
		Z	8.20	77.5	27.3		132.2	
10252-CAB	LTE-TDD (SC-FDMA, 50% RB, 10 MHz, QPSK)	X	9.16	74.5	25.8	9.24	126.3	±3.0 %
		Y	9.62	75.0	25.8		137.4	
		Z	9.16	74.8	25.9		135.2	
10267-CAB	LTE-TDD (SC-FDMA, 100% RB, 10 MHz, QPSK)	X	9.97	75.7	26.3	9.30	133.7	±3.3 %
		Y	10.38	75.9	26.1		146.1	
		Z	9.91	75.7	26.3		143.8	
10274-CAB	UMTS-FDD (HSUPA, Subtest 5, 3GPP Rel8.10)	X	5.86	66.6	18.7	4.87	129.9	±0.9 %
		Y	6.01	67.1	19.0		135.7	
		Z	5.95	67.1	19.0		139.4	
10275-CAB	UMTS-FDD (HSUPA, Subtest 5, 3GPP Rel8.4)	X	4.40	66.7	18.6	3.96	136.4	±0.7 %
		Y	4.55	67.3	19.0		138.3	
		Z	4.56	67.6	19.1		144.3	
10291-AAB	CDMA2000, RC3, SO55, Full Rate	X	3.64	66.9	18.7	3.46	127.4	±0.5 %
		Y	3.77	67.6	19.1		130.2	
		Z	3.72	67.5	19.0		134.4	
10292-AAB	CDMA2000, RC3, SO32, Full Rate	X	3.58	67.0	18.7	3.39	128.4	±0.5 %
		Y	3.73	67.7	19.1		132.7	
		Z	3.69	67.8	19.1		136.1	
10297-AAA	LTE-FDD (SC-FDMA, 50% RB, 20 MHz, QPSK)	X	6.43	67.7	19.9	5.81	145.5	±1.4 %
		Y	6.49	67.7	19.9		149.5	
		Z	6.23	67.0	19.6		129.5	
10311-AAA	LTE-FDD (SC-FDMA, 100% RB, 15 MHz, QPSK)	X	6.74	67.3	19.8	6.06	126.7	±1.4 %
		Y	6.83	67.5	19.8		132.9	
		Z	6.81	67.6	19.9		135.8	
10315-AAA	IEEE 802.11b WiFi 2.4 GHz (DSSS, 1 Mbps, 96pc duty cycle)	X	3.00	69.9	19.4	1.71	133.9	±0.5 %
		Y	3.30	71.5	20.1		141.0	
		Z	3.22	71.4	20.0		142.9	
10316-AAA	IEEE 802.11g WiFi 2.4 GHz (ERP-OFDM, 6 Mbps, 96pc duty cycle)	X	10.17	69.2	21.8	8.36	130.5	±2.5 %
		Y	10.20	69.1	21.6		138.4	
		Z	10.20	69.4	21.8		140.7	

10403-AAB	CDMA2000 (1xEV-DO, Rev. 0)	X	4.75	68.3	18.8	3.76	138.5	±0.7 %
		Y	5.00	69.1	19.2		146.7	
		Z	4.92	69.2	19.1		148.5	
10404-AAB	CDMA2000 (1xEV-DO, Rev. A)	X	4.73	68.6	18.9	3.77	136.3	±0.7 %
		Y	4.97	69.4	19.4		143.7	
		Z	4.91	69.6	19.3		146.0	
10415-AAA	IEEE 802.11b WiFi 2.4 GHz (DSSS, 1 Mbps, 99pc duty cycle)	X	2.65	68.1	18.5	1.54	135.2	±0.5 %
		Y	3.05	70.8	19.9		140.7	
		Z	2.87	69.8	19.3		144.8	
10416-AAA	IEEE 802.11g WiFi 2.4 GHz (ERP-OFDM, 6 Mbps, 99pc duty cycle)	X	10.00	69.0	21.5	8.23	130.8	±2.2 %
		Y	10.06	68.9	21.4		138.6	
		Z	10.08	69.3	21.7		141.6	

The reported uncertainty of measurement is stated as the standard uncertainty of measurement multiplied by the coverage factor $k=2$, which for a normal distribution corresponds to a coverage probability of approximately 95%.

^A The uncertainties of NormX,Y,Z do not affect the E²-field uncertainty inside TSL (see Pages 8 and 9).

^B Numerical linearization parameter: uncertainty not required.

^E Uncertainty is determined using the max. deviation from linear response applying rectangular distribution and is expressed for the square of the field value.

DASY/EASY - Parameters of Probe: ES3DV3 - SN:3288

Calibration Parameter Determined in Head Tissue Simulating Media

f (MHz) ^C	Relative Permittivity ^F	Conductivity (S/m) ^F	ConvF X	ConvF Y	ConvF Z	Alpha ^G	Depth ^G (mm)	Unct. (k=2)
750	41.9	0.89	6.81	6.81	6.81	0.37	1.70	± 12.0 %
835	41.5	0.90	6.51	6.51	6.51	0.45	1.52	± 12.0 %
1750	40.1	1.37	5.38	5.38	5.38	0.44	1.58	± 12.0 %
1900	40.0	1.40	5.17	5.17	5.17	0.80	1.18	± 12.0 %
2450	39.2	1.80	4.56	4.56	4.56	0.80	1.21	± 12.0 %
2600	39.0	1.96	4.44	4.44	4.44	0.80	1.22	± 12.0 %

^C Frequency validity above 300 MHz of ± 100 MHz only applies for DASY v4.4 and higher (see Page 2), else it is restricted to ± 50 MHz. The uncertainty is the RSS of the ConvF uncertainty at calibration frequency and the uncertainty for the indicated frequency band. Frequency validity below 300 MHz is ± 10, 25, 40, 50 and 70 MHz for ConvF assessments at 30, 64, 128, 150 and 220 MHz respectively. Above 5 GHz frequency validity can be extended to ± 110 MHz.

^F At frequencies below 3 GHz, the validity of tissue parameters (ϵ and σ) can be relaxed to ± 10% if liquid compensation formula is applied to measured SAR values. At frequencies above 3 GHz, the validity of tissue parameters (ϵ and σ) is restricted to ± 5%. The uncertainty is the RSS of the ConvF uncertainty for indicated target tissue parameters.

^G Alpha/Depth are determined during calibration. SPEAG warrants that the remaining deviation due to the boundary effect after compensation is always less than ± 1% for frequencies below 3 GHz and below ± 2% for frequencies between 3-6 GHz at any distance larger than half the probe tip diameter from the boundary.

DASY/EASY - Parameters of Probe: ES3DV3 - SN:3288

Calibration Parameter Determined in Body Tissue Simulating Media

f (MHz) ^C	Relative Permittivity ^F	Conductivity (S/m) ^F	ConvF X	ConvF Y	ConvF Z	Alpha ^G	Depth ^G (mm)	Unct. (k=2)
750	55.5	0.96	6.38	6.38	6.38	0.31	1.89	± 12.0 %
835	55.2	0.97	6.32	6.32	6.32	0.55	1.39	± 12.0 %
1750	53.4	1.49	5.03	5.03	5.03	0.57	1.44	± 12.0 %
1900	53.3	1.52	4.82	4.82	4.82	0.51	1.54	± 12.0 %
2450	52.7	1.95	4.36	4.36	4.36	0.71	1.07	± 12.0 %
2600	52.5	2.16	4.22	4.22	4.22	0.80	1.07	± 12.0 %

^C Frequency validity above 300 MHz of ± 100 MHz only applies for DASY v4.4 and higher (see Page 2), else it is restricted to ± 50 MHz. The uncertainty is the RSS of the ConvF uncertainty at calibration frequency and the uncertainty for the indicated frequency band. Frequency validity below 300 MHz is ± 10, 25, 40, 50 and 70 MHz for ConvF assessments at 30, 64, 128, 150 and 220 MHz respectively. Above 5 GHz frequency validity can be extended to ± 110 MHz.

^F At frequencies below 3 GHz, the validity of tissue parameters (ϵ and σ) can be relaxed to ± 10% if liquid compensation formula is applied to measured SAR values. At frequencies above 3 GHz, the validity of tissue parameters (ϵ and σ) is restricted to ± 5%. The uncertainty is the RSS of the ConvF uncertainty for indicated target tissue parameters.

^G Alpha/Depth are determined during calibration. SPEAG warrants that the remaining deviation due to the boundary effect after compensation is always less than ± 1% for frequencies below 3 GHz and below ± 2% for frequencies between 3-6 GHz at any distance larger than half the probe tip diameter from the boundary.

Frequency Response of E-Field

(TEM-Cell:ifi1110 EXX, Waveguide: R22)

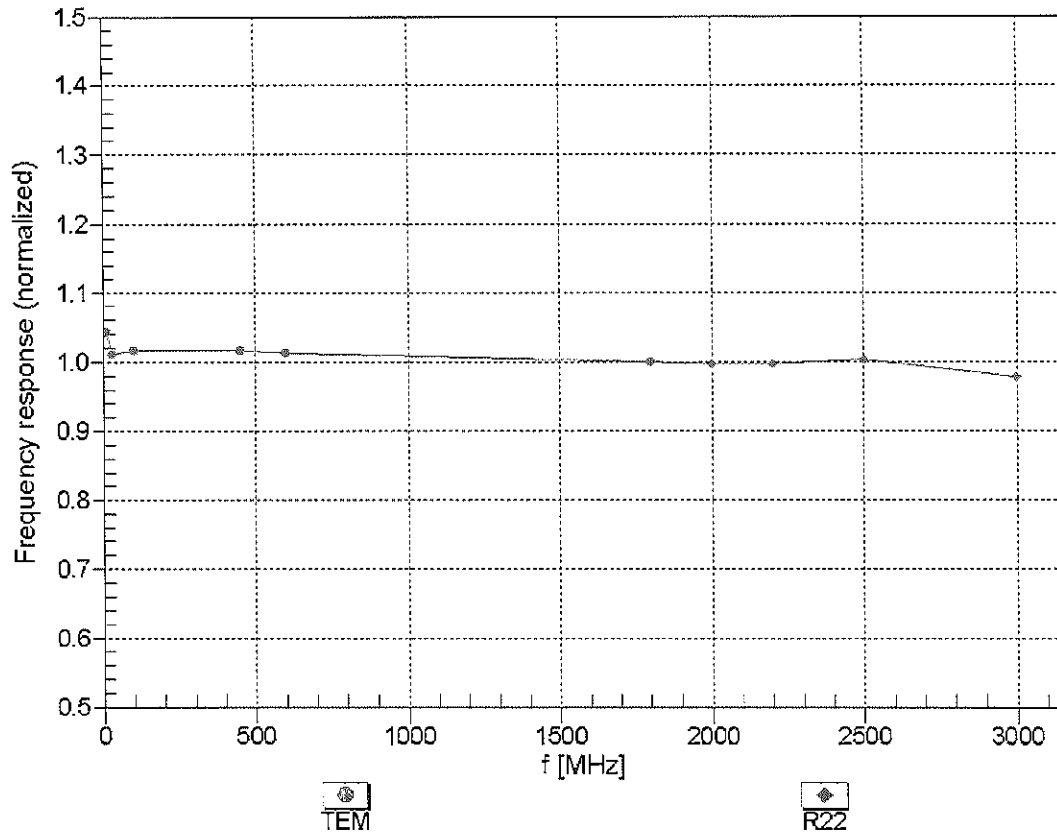

Uncertainty of Frequency Response of E-field: $\pm 6.3\%$ (k=2)

Receiving Pattern (ϕ), $\vartheta = 0^\circ$

f=600 MHz, TEM

f=1800 MHz, R22

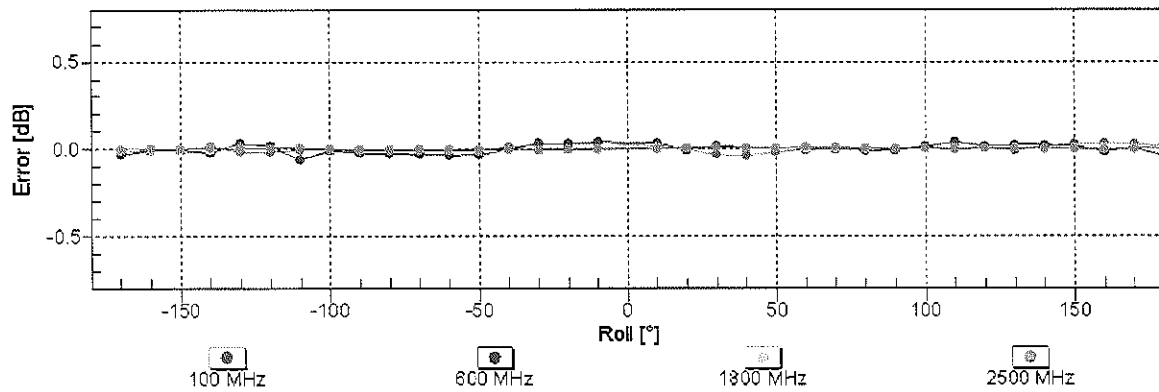
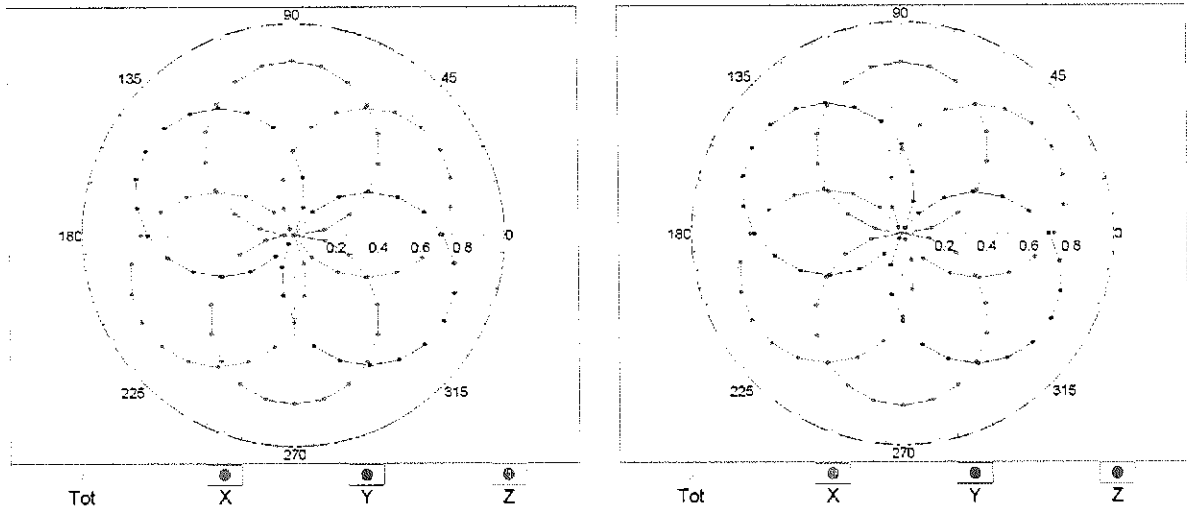

Uncertainty of Axial Isotropy Assessment: $\pm 0.5\%$ (k=2)

Dynamic Range $f(\text{SAR}_{\text{head}})$ (TEM cell , $f_{\text{eval}}= 1900 \text{ MHz}$)

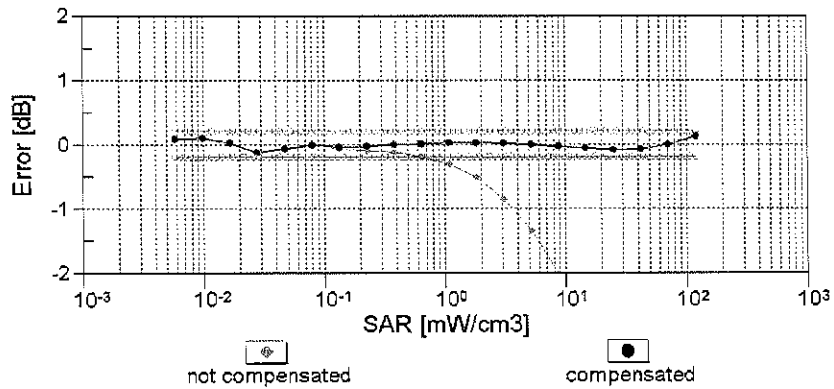
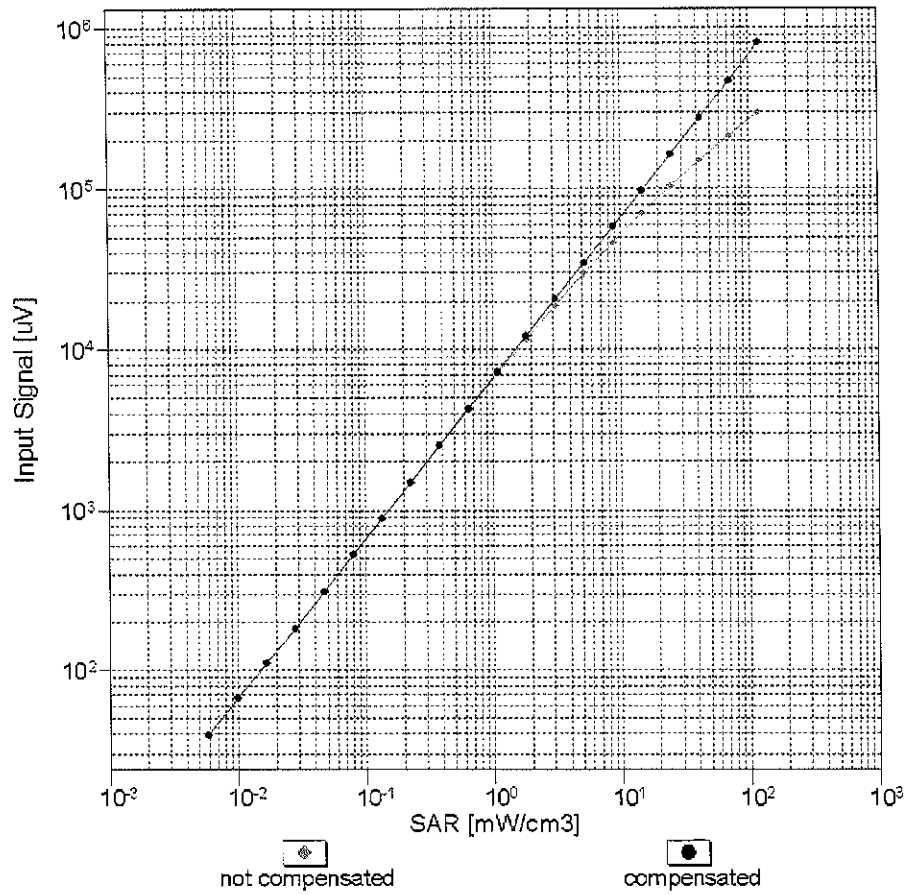

Uncertainty of Linearity Assessment: $\pm 0.6\%$ ($k=2$)

Conversion Factor Assessment

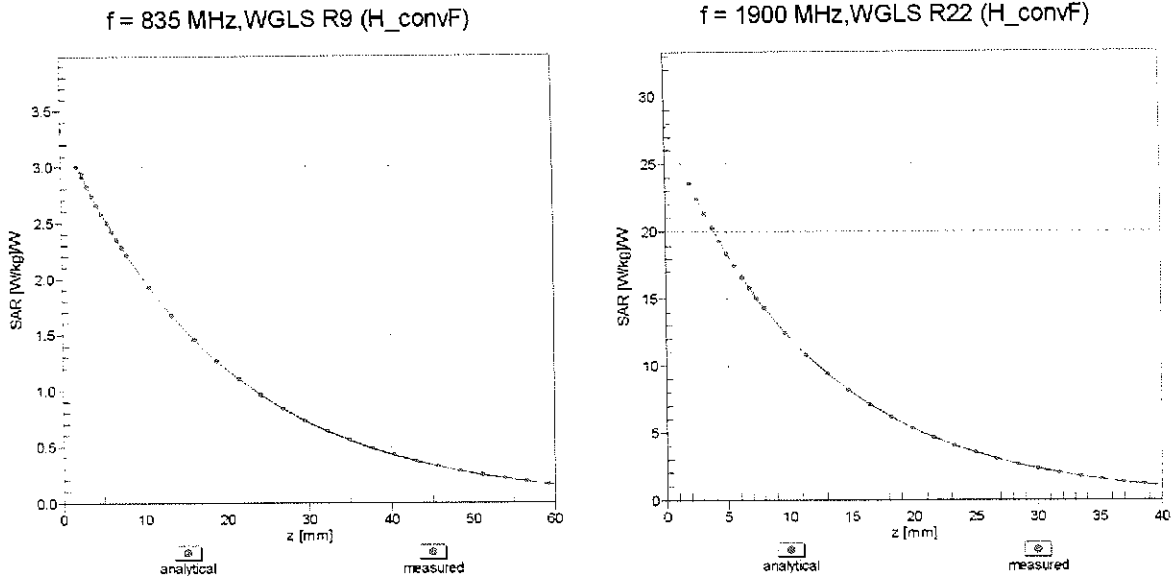

Deviation from Isotropy in Liquid

Error (ϕ, θ), f = 900 MHz

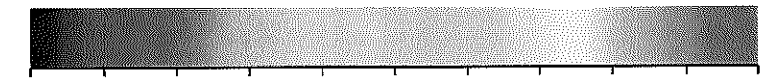
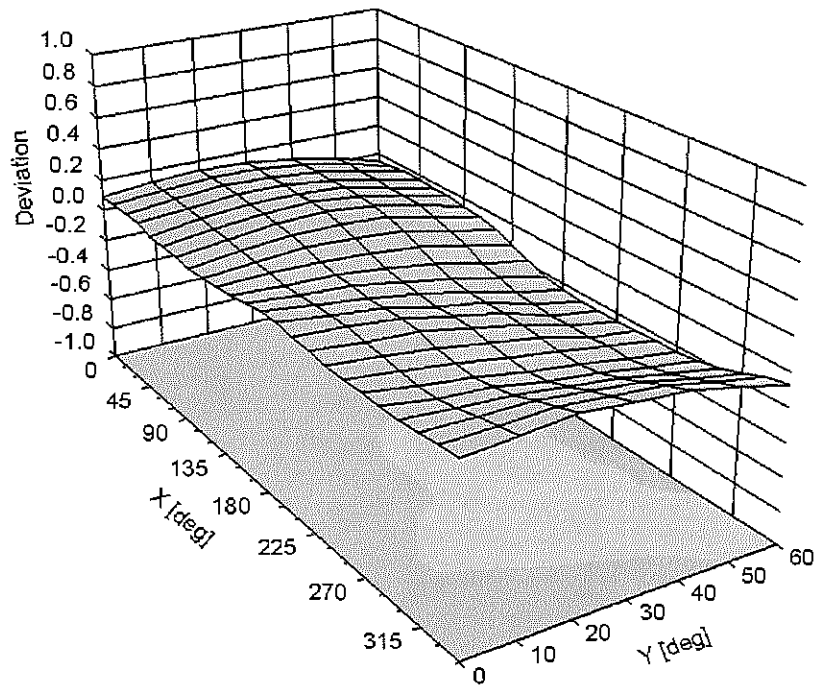

Uncertainty of Spherical Isotropy Assessment: $\pm 2.6\%$ (k=2)

DASY/EASY - Parameters of Probe: ES3DV3 - SN:3288

Other Probe Parameters

Sensor Arrangement	Triangular
Connector Angle (°)	-110
Mechanical Surface Detection Mode	enabled
Optical Surface Detection Mode	disabled
Probe Overall Length	337 mm
Probe Body Diameter	10 mm
Tip Length	10 mm
Tip Diameter	4 mm
Probe Tip to Sensor X Calibration Point	2 mm
Probe Tip to Sensor Y Calibration Point	2 mm
Probe Tip to Sensor Z Calibration Point	2 mm
Recommended Measurement Distance from Surface	3 mm

**Calibration Laboratory of
Schmid & Partner
Engineering AG**
Zeughausstrasse 43, 8004 Zurich, Switzerland



S Schweizerischer Kalibrierdienst
C Service suisse d'étalonnage
S Servizio svizzero di taratura
Swiss Calibration Service

Accredited by the Swiss Accreditation Service (SAS)
The Swiss Accreditation Service is one of the signatories to the EA
Multilateral Agreement for the recognition of calibration certificates

Accreditation No.: **SCS 108**

Client **PC Test**

Certificate No: **ES3-3022_Aug14/2**

CALIBRATION CERTIFICATE (Replacement of No: ES3-3022_Aug14)

Object **ES3DV2 - SN:3022**

Calibration procedure(s) **QA CAL-01.v9, QA CAL-12.v9, QA CAL-23.v5, QA CAL-25.v6
Calibration procedure for dosimetric E-field probes** CC
D/M/14

Calibration date: **August 19, 2014**

This calibration certificate documents the traceability to national standards, which realize the physical units of measurements (SI).
The measurements and the uncertainties with confidence probability are given on the following pages and are part of the certificate.

All calibrations have been conducted in the closed laboratory facility: environment temperature (22 ± 3)°C and humidity < 70%.

Calibration Equipment used (M&TE critical for calibration)

Primary Standards	ID	Cal Date (Certificate No.)	Scheduled Calibration
Power meter E4419B	GB41293874	03-Apr-14 (No. 217-01911)	Apr-15
Power sensor E4412A	MY41498087	03-Apr-14 (No. 217-01911)	Apr-15
Reference 3 dB Attenuator	SN: S5054 (3c)	03-Apr-14 (No. 217-01915)	Apr-15
Reference 20 dB Attenuator	SN: S5277 (20x)	03-Apr-14 (No. 217-01919)	Apr-15
Reference 30 dB Attenuator	SN: S5129 (30b)	03-Apr-14 (No. 217-01920)	Apr-15
Reference Probe ES3DV2	SN: 3013	30-Dec-13 (No. ES3-3013_Dec13)	Dec-14
DAE4	SN: 660	13-Dec-13 (No. DAE4-660_Dec13)	Dec-14
Secondary Standards	ID	Check Date (in house)	Scheduled Check
RF generator HP 8648C	US3642U01700	4-Aug-99 (in house check Apr-13)	In house check: Apr-16
Network Analyzer HP 8753E	US37390585	18-Oct-01 (in house check Oct-13)	In house check: Oct-14

Calibrated by:	Name Jeton Kastrali	Function Laboratory Technician	Signature
Approved by:	Name Katja Pokovic	Function Technical Manager	

Issued: November 3, 2014

This calibration certificate shall not be reproduced except in full without written approval of the laboratory.



Accredited by the Swiss Accreditation Service (SAS)
The Swiss Accreditation Service is one of the signatories to the EA
Multilateral Agreement for the recognition of calibration certificates

Accreditation No.: **SCS 108**

Glossary:

TSL	tissue simulating liquid
NORM _{x,y,z}	sensitivity in free space
ConvF	sensitivity in TSL / NORM _{x,y,z}
DCP	diode compression point
CF	crest factor (1/duty_cycle) of the RF signal
A, B, C, D	modulation dependent linearization parameters
Polarization φ	φ rotation around probe axis
Polarization ϑ	ϑ rotation around an axis that is in the plane normal to probe axis (at measurement center), i.e., $\vartheta = 0$ is normal to probe axis
Connector Angle	information used in DASY system to align probe sensor X to the robot coordinate system

Calibration is Performed According to the Following Standards:

- IEEE Std 1528-2013, "IEEE Recommended Practice for Determining the Peak Spatial-Averaged Specific Absorption Rate (SAR) in the Human Head from Wireless Communications Devices: Measurement Techniques", June 2013
- IEC 62209-1, "Procedure to measure the Specific Absorption Rate (SAR) for hand-held devices used in close proximity to the ear (frequency range of 300 MHz to 3 GHz)", February 2005

Methods Applied and Interpretation of Parameters:

- NORM_{x,y,z}**: Assessed for E-field polarization $\vartheta = 0$ ($f \leq 900$ MHz in TEM-cell; $f > 1800$ MHz: R22 waveguide). NORM_{x,y,z} are only intermediate values, i.e., the uncertainties of NORM_{x,y,z} does not affect the E²-field uncertainty inside TSL (see below ConvF).
- NORM(f)_{x,y,z}** = NORM_{x,y,z} * frequency_response (see Frequency Response Chart). This linearization is implemented in DASY4 software versions later than 4.2. The uncertainty of the frequency response is included in the stated uncertainty of ConvF.
- DCP_{x,y,z}**: DCP are numerical linearization parameters assessed based on the data of power sweep with CW signal (no uncertainty required). DCP does not depend on frequency nor media.
- PAR**: PAR is the Peak to Average Ratio that is not calibrated but determined based on the signal characteristics
- A_{x,y,z}; B_{x,y,z}; C_{x,y,z}; D_{x,y,z}; VR_{x,y,z}; A, B, C, D** are numerical linearization parameters assessed based on the data of power sweep for specific modulation signal. The parameters do not depend on frequency nor media. VR is the maximum calibration range expressed in RMS voltage across the diode.
- ConvF and Boundary Effect Parameters**: Assessed in flat phantom using E-field (or Temperature Transfer Standard for $f \leq 800$ MHz) and inside waveguide using analytical field distributions based on power measurements for $f > 800$ MHz. The same setups are used for assessment of the parameters applied for boundary compensation (alpha, depth) of which typical uncertainty values are given. These parameters are used in DASY4 software to improve probe accuracy close to the boundary. The sensitivity in TSL corresponds to NORM_{x,y,z} * ConvF whereby the uncertainty corresponds to that given for ConvF. A frequency dependent ConvF is used in DASY version 4.4 and higher which allows extending the validity from ± 50 MHz to ± 100 MHz.
- Spherical isotropy (3D deviation from isotropy)**: in a field of low gradients realized using a flat phantom exposed by a patch antenna.
- Sensor Offset**: The sensor offset corresponds to the offset of virtual measurement center from the probe tip (on probe axis). No tolerance required.
- Connector Angle**: The angle is assessed using the information gained by determining the NORM_x (no uncertainty required).

Probe ES3DV2

SN:3022

Manufactured: April 15, 2003
Calibrated: August 19, 2014

Calibrated for DASY/EASY Systems
(Note: non-compatible with DASY2 system!)

DASY/EASY - Parameters of Probe: ES3DV2 - SN:3022

Basic Calibration Parameters

	Sensor X	Sensor Y	Sensor Z	Unc (k=2)
Norm ($\mu\text{V}/(\text{V}/\text{m})^2$) ^A	1.00	1.04	0.96	$\pm 10.1\%$
DCP (mV) ^B	103.0	96.3	101.6	

Modulation Calibration Parameters

UID	Communication System Name		A dB	B dB $\sqrt{\mu\text{V}}$	C	D dB	VR mV	Unc ^E (k=2)
0	CW	X	0.0	0.0	1.0	0.00	181.8	$\pm 2.7\%$
		Y	0.0	0.0	1.0		183.0	
		Z	0.0	0.0	1.0		192.3	
10010- CAA	SAR Validation (Square, 100ms, 10ms)	X	2.51	63.1	12.7	10.00	42.6	$\pm 1.9\%$
		Y	2.62	63.1	12.9		42.7	
		Z	3.12	65.7	13.6		40.4	
10011- CAB	UMTS-FDD (WCDMA)	X	3.33	67.8	19.2	2.91	145.9	$\pm 0.9\%$
		Y	3.13	64.9	16.9		147.4	
		Z	3.20	66.4	18.2		139.6	
10012- CAA	IEEE 802.11b WiFi 2.4 GHz (DSSS, 1 Mbps)	X	3.05	70.1	19.8	1.87	147.2	$\pm 0.9\%$
		Y	2.62	65.1	16.2		147.4	
		Z	2.85	68.2	18.4		141.7	
10013- CAA	IEEE 802.11g WiFi 2.4 GHz (DSSS-OFDM, 6 Mbps)	X	11.10	70.9	23.6	9.46	143.9	$\pm 3.0\%$
		Y	11.04	70.2	22.9		144.2	
		Z	10.77	70.2	23.1		134.7	
10021- DAB	GSM-FDD (TDMA, GMSK)	X	19.66	99.7	28.6	9.39	126.0	$\pm 1.9\%$
		Y	11.04	89.6	25.5		138.9	
		Z	10.45	88.8	24.9		137.5	
10023- DAB	GPRS-FDD (TDMA, GMSK, TN 0)	X	20.19	99.6	28.5	9.57	142.0	$\pm 2.5\%$
		Y	10.53	88.4	25.0		145.5	
		Z	15.52	96.5	27.8		147.6	
10024- DAB	GPRS-FDD (TDMA, GMSK, TN 0-1)	X	31.93	99.6	25.2	6.56	149.5	$\pm 1.9\%$
		Y	12.70	87.9	22.2		148.0	
		Z	27.00	99.8	25.7		135.3	
10027- DAB	GPRS-FDD (TDMA, GMSK, TN 0-1-2)	X	38.32	99.8	23.8	4.80	148.1	$\pm 2.2\%$
		Y	9.80	83.2	19.3		138.8	
		Z	31.96	99.9	24.2		128.9	
10028- DAB	GPRS-FDD (TDMA, GMSK, TN 0-1-2-3)	X	40.03	99.5	22.8	3.55	130.5	$\pm 2.2\%$
		Y	40.27	99.6	23.0		148.1	
		Z	43.09	99.7	22.5		140.1	
10032- CAA	IEEE 802.15.1 Bluetooth (GFSK, DH5)	X	38.93	99.4	20.4	1.16	146.7	$\pm 1.9\%$
		Y	32.83	92.5	17.9		139.2	
		Z	31.94	99.5	20.8		133.1	
10039- CAB	CDMA2000 (1xRTT, RC1)	X	4.66	66.8	19.3	4.57	144.5	$\pm 1.2\%$
		Y	4.56	65.3	17.9		137.2	
		Z	4.52	66.1	18.7		131.7	

10081-CAB	CDMA2000 (1xRTT, RC3)	X	3.82	66.0	18.7	3.97	140.3	±0.9 %
		Y	3.77	64.5	17.3		133.6	
		Z	3.79	65.7	18.4		128.2	
10098-CAB	UMTS-FDD (HSUPA, Subtest 2)	X	4.40	66.2	18.5	3.98	130.9	±1.2 %
		Y	4.39	65.0	17.4		131.1	
		Z	4.47	66.3	18.4		140.0	
10100-CAB	LTE-FDD (SC-FDMA, 100% RB, 20 MHz, QPSK)	X	6.30	67.3	19.8	5.67	137.4	±1.7 %
		Y	6.25	66.3	18.9		135.9	
		Z	6.36	67.4	19.7		147.5	
10108-CAB	LTE-FDD (SC-FDMA, 100% RB, 10 MHz, QPSK)	X	6.14	66.8	19.6	5.80	134.6	±1.7 %
		Y	6.17	66.1	18.9		133.9	
		Z	6.24	67.0	19.7		144.5	
10110-CAB	LTE-FDD (SC-FDMA, 100% RB, 6 MHz, QPSK)	X	5.82	66.3	19.4	5.75	131.2	±1.7 %
		Y	5.82	65.4	18.6		130.3	
		Z	5.91	66.5	19.4		140.4	
10114-CAA	IEEE 802.11n (HT Greenfield, 13.5 Mbps, BPSK)	X	10.00	68.5	21.2	8.10	124.3	±2.5 %
		Y	9.89	67.9	20.6		124.0	
		Z	10.05	68.6	21.2		133.2	
10117-CAA	IEEE 802.11n (HT Mixed, 13.5 Mbps, BPSK)	X	10.01	68.6	21.2	8.07	125.8	±2.5 %
		Y	9.91	67.9	20.7		125.8	
		Z	10.09	68.8	21.3		134.7	
10151-CAB	LTE-TDD (SC-FDMA, 50% RB, 20 MHz, QPSK)	X	9.69	75.5	26.4	9.28	144.7	±3.3 %
		Y	9.09	72.7	24.6		143.2	
		Z	8.54	72.0	24.5		124.8	
10154-CAB	LTE-FDD (SC-FDMA, 50% RB, 10 MHz, QPSK)	X	5.82	66.2	19.4	5.75	131.3	±1.9 %
		Y	6.06	66.3	19.1		149.2	
		Z	5.91	66.5	19.4		140.7	
10160-CAB	LTE-FDD (SC-FDMA, 50% RB, 15 MHz, QPSK)	X	6.27	66.9	19.7	5.82	136.5	±1.4 %
		Y	6.19	65.8	18.7		128.4	
		Z	6.33	67.0	19.6		145.4	
10169-CAB	LTE-FDD (SC-FDMA, 1 RB, 20 MHz, QPSK)	X	4.81	66.4	19.7	5.73	134.8	±1.7 %
		Y	4.92	66.1	19.1		149.9	
		Z	4.78	66.4	19.6		141.2	
10172-CAB	LTE-TDD (SC-FDMA, 1 RB, 20 MHz, QPSK)	X	7.83	76.6	27.2	9.21	131.4	±3.5 %
		Y	7.54	74.5	25.8		147.8	
		Z	7.71	76.7	27.4		145.3	
10175-CAB	LTE-FDD (SC-FDMA, 1 RB, 10 MHz, QPSK)	X	4.90	66.9	20.0	5.72	147.6	±1.4 %
		Y	4.90	66.0	19.1		148.0	
		Z	4.78	66.4	19.6		141.6	
10181-CAB	LTE-FDD (SC-FDMA, 1 RB, 15 MHz, QPSK)	X	4.90	66.9	20.0	5.72	148.1	±1.4 %
		Y	4.89	65.9	19.0		146.9	
		Z	4.80	66.5	19.7		142.1	
10193-CAA	IEEE 802.11n (HT Greenfield, 6.5 Mbps, BPSK)	X	9.80	68.7	21.4	8.09	135.1	±2.7 %
		Y	9.78	68.2	20.9		135.5	
		Z	9.70	68.5	21.2		130.2	

10196-CAA	IEEE 802.11n (HT Mixed, 6.5 Mbps, BPSK)	X	9.79	68.7	21.4	8.10	136.4	±2.7 %
		Y	9.81	68.3	20.9		138.0	
		Z	9.72	68.6	21.3		132.8	
10219-CAA	IEEE 802.11n (HT Mixed, 7.2 Mbps, BPSK)	X	9.68	68.6	21.3	8.03	136.0	±2.7 %
		Y	9.74	68.3	21.0		137.4	
		Z	9.62	68.5	21.2		132.6	
10222-CAA	IEEE 802.11n (HT Mixed, 15 Mbps, BPSK)	X	10.20	69.1	21.5	8.06	143.4	±2.5 %
		Y	9.91	60.0	20.7		125.8	
		Z	10.27	69.4	21.6		148.4	
10225-CAB	UMTS-FDD (HSPA+)	X	6.87	66.9	19.6	5.97	139.5	±1.9 %
		Y	7.04	66.9	19.3		149.3	
		Z	6.89	67.0	19.5		143.5	
10237-CAB	LTE-TDD (SC-FDMA, 1 RB, 10 MHz, QPSK)	X	7.66	75.9	26.9	9.21	126.1	±3.0 %
		Y	7.17	73.1	25.1		132.1	
		Z	7.18	74.6	26.3		128.0	
10252-CAB	LTE-TDD (SC-FDMA, 50% RB, 10 MHz, QPSK)	X	8.58	73.1	25.3	9.24	127.6	±3.3 %
		Y	8.22	71.0	23.7		126.9	
		Z	8.83	74.3	26.0		149.8	
10267-CAB	LTE-TDD (SC-FDMA, 100% RB, 10 MHz, QPSK)	X	9.69	75.5	26.5	9.30	143.8	±3.3 %
		Y	8.88	72.0	24.2		135.2	
		Z	8.83	72.9	25.1		131.3	
10274-CAB	UMTS-FDD (HSUPA, Subtest 5, 3GPP Rel8.10)	X	5.87	67.0	19.2	4.87	141.2	±1.4 %
		Y	5.77	65.8	18.1		136.0	
		Z	5.71	66.3	18.6		132.7	
10275-CAB	UMTS-FDD (HSUPA, Subtest 5, 3GPP Rel8.4)	X	4.44	67.2	19.2	3.96	147.3	±0.9 %
		Y	4.29	65.3	17.6		139.2	
		Z	4.31	66.3	18.5		139.6	
10291-AAB	CDMA2000, RC3, SO55, Full Rate	X	3.60	67.1	19.1	3.46	137.8	±0.7 %
		Y	3.44	64.8	17.2		129.6	
		Z	3.48	66.2	18.4		130.5	
10292-AAB	CDMA2000, RC3, SO32, Full Rate	X	3.50	66.9	18.9	3.39	139.5	±0.7 %
		Y	3.38	64.8	17.2		132.0	
		Z	3.48	66.5	18.5		133.1	
10297-AAA	LTE-FDD (SC-FDMA, 50% RB, 20 MHz, QPSK)	X	6.12	66.7	19.6	5.81	133.3	±1.9 %
		Y	6.35	66.7	19.3		149.3	
		Z	6.17	66.8	19.5		132.7	
10311-AAA	LTE-FDD (SC-FDMA, 100% RB, 15 MHz, QPSK)	X	6.72	67.4	20.0	6.06	138.7	±1.7 %
		Y	6.63	66.3	19.1		131.4	
		Z	6.72	67.3	19.9		138.7	
10315-AAA	IEEE 802.11b WiFi 2.4 GHz (DSSS, 1 Mbps, 96pc duty cycle)	X	2.90	69.9	19.8	1.71	146.4	±0.5 %
		Y	2.54	65.2	16.5		139.3	
		Z	2.75	68.1	18.5		146.4	
10316-AAA	IEEE 802.11g WiFi 2.4 GHz (ERP-OFDM, 6 Mbps, 96pc duty cycle)	X	10.12	69.3	21.9	8.36	142.9	±3.0 %
		Y	10.01	68.5	21.3		135.2	
		Z	10.11	69.3	21.9		141.7	

10403-AAB	CDMA2000 (1xEV-DO, Rev. 0)	X	4.59	68.2	19.0	3.76	126.7	±0.7 %
		Y	4.59	67.2	18.0		142.4	
		Z	4.64	68.5	19.0		143.0	
10404-AAB	CDMA2000 (1xEV-DO, Rev. A)	X	4.64	68.8	19.3	3.77	147.1	±0.9 %
		Y	4.47	67.1	17.9		139.6	
		Z	4.54	68.4	18.9		147.2	
10415-AAA	IEEE 802.11b WiFi 2.4 GHz (DSSS, 1 Mbps, 99pc duty cycle)	X	2.66	69.0	19.4	1.54	145.8	±0.5 %
		Y	2.40	64.8	16.2		140.0	
		Z	2.62	67.8	18.4		147.2	
10416-AAA	IEEE 802.11g WiFi 2.4 GHz (ERP-OFDM, 6 Mbps, 99pc duty cycle)	X	9.97	69.1	21.7	8.23	142.0	±3.0 %
		Y	10.08	68.9	21.4		145.8	
		Z	10.01	69.2	21.8		143.3	

The reported uncertainty of measurement is stated as the standard uncertainty of measurement multiplied by the coverage factor $k=2$, which for a normal distribution corresponds to a coverage probability of approximately 95%.

[^] The uncertainties of NormX,Y,Z do not affect the E^2 -field uncertainty inside TSL (see Pages 8 and 9).

[^] Numerical linearization parameter: uncertainty not required.

[^] Uncertainty is determined using the max. deviation from linear response applying rectangular distribution and is expressed for the square of the field value.

DASY/EASY - Parameters of Probe: ES3DV2 - SN:3022

Calibration Parameter Determined in Head Tissue Simulating Media

f (MHz) ^c	Relative Permittivity ^F	Conductivity (S/m) ^F	ConvF X	ConvF Y	ConvF Z	Alpha ^G	Depth ^G (mm)	Unct. (k=2)
750	41.9	0.89	6.39	6.39	6.39	0.20	2.24	± 12.0 %
835	41.5	0.90	6.18	6.18	6.18	0.23	1.98	± 12.0 %
1750	40.1	1.37	5.04	5.04	5.04	0.51	1.35	± 12.0 %
1900	40.0	1.40	4.85	4.85	4.85	0.38	1.66	± 12.0 %
2450	39.2	1.80	4.31	4.31	4.31	0.66	1.28	± 12.0 %
2600	39.0	1.96	4.13	4.13	4.13	0.76	1.28	± 12.0 %

^c Frequency validity above 300 MHz of ± 100 MHz only applies for DASY v4.4 and higher (see Page 2), else it is restricted to ± 50 MHz. The uncertainty is the RSS of the ConvF uncertainty at calibration frequency and the uncertainty for the indicated frequency band. Frequency validity below 300 MHz is ± 10, 25, 40, 50 and 70 MHz for ConvF assessments at 30, 64, 128, 150 and 220 MHz respectively. Above 5 GHz frequency validity can be extended to ± 110 MHz.

^F At frequencies below 3 GHz, the validity of tissue parameters (ϵ and σ) can be relaxed to ± 10% if liquid compensation formula is applied to measured SAR values. At frequencies above 3 GHz, the validity of tissue parameters (ϵ and σ) is restricted to ± 5%. The uncertainty is the RSS of the ConvF uncertainty for indicated target tissue parameters.

^G Alpha/Depth are determined during calibration. SPEAG warrants that the remaining deviation due to the boundary effect after compensation is always less than ± 1% for frequencies below 3 GHz and below ± 2% for frequencies between 3-6 GHz at any distance larger than half the probe tip diameter from the boundary.

DASY/EASY - Parameters of Probe: ES3DV2 - SN:3022

Calibration Parameter Determined in Body Tissue Simulating Media

f (MHz) ^c	Relative Permittivity ^F	Conductivity (S/m) ^F	ConvF X	ConvF Y	ConvF Z	Alpha ^g	Depth ^g (mm)	Unct. (k=2)
450	56.7	0.94	6.78	6.78	6.78	0.12	1.30	± 13.3 %
600	56.1	0.95	6.72	6.72	6.72	0.05	1.20	± 13.3 %
750	55.5	0.96	6.02	6.02	6.02	0.23	2.05	± 12.0 %
835	55.2	0.97	5.98	5.98	5.98	0.29	1.85	± 12.0 %
1750	53.4	1.49	4.70	4.70	4.70	0.66	1.25	± 12.0 %
1900	53.3	1.52	4.49	4.49	4.49	0.33	2.02	± 12.0 %
2450	52.7	1.95	4.05	4.05	4.05	0.80	1.01	± 12.0 %
2600	52.5	2.16	3.94	3.94	3.94	0.68	1.03	± 12.0 %

^c Frequency validity above 300 MHz of ± 100 MHz only applies for DASY v4.4 and higher (see Page 2), else it is restricted to ± 50 MHz. The uncertainty is the RSS of the ConvF uncertainty at calibration frequency and the uncertainty for the indicated frequency band. Frequency validity below 300 MHz is ± 10, 25, 40, 50 and 70 MHz for ConvF assessments at 30, 64, 128, 150 and 220 MHz respectively. Above 5 GHz frequency validity can be extended to ± 110 MHz.

^F At frequencies below 3 GHz, the validity of tissue parameters (ϵ and σ) can be relaxed to ± 10% if liquid compensation formula is applied to measured SAR values. At frequencies above 3 GHz, the validity of tissue parameters (ϵ and σ) is restricted to ± 5%. The uncertainty is the RSS of the ConvF uncertainty for indicated target tissue parameters.

^g Alpha/Depth are determined during calibration. SPEAG warrants that the remaining deviation due to the boundary effect after compensation is always less than ± 1% for frequencies below 3 GHz and below ± 2% for frequencies between 3-6 GHz at any distance larger than half the probe tip diameter from the boundary.

Frequency Response of E-Field (TEM-Cell:ifi110 EXX, Waveguide: R22)

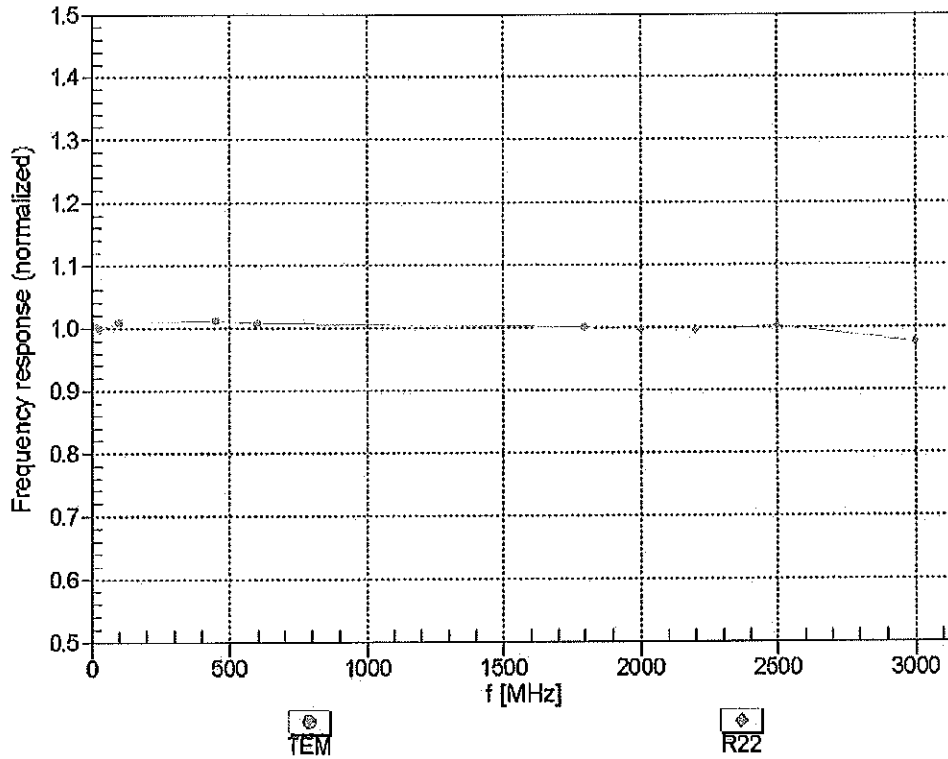

Uncertainty of Frequency Response of E-field: $\pm 6.3\%$ (k=2)

Receiving Pattern (ϕ), $\theta = 0^\circ$

f=600 MHz,TEM

f=1800 MHz,R22

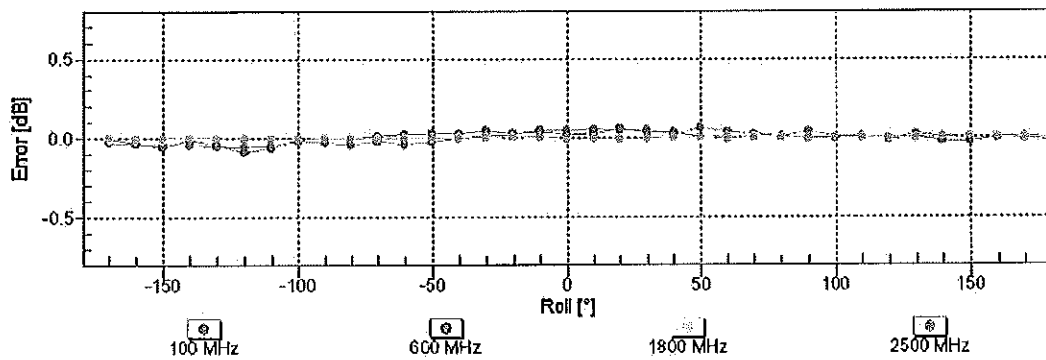
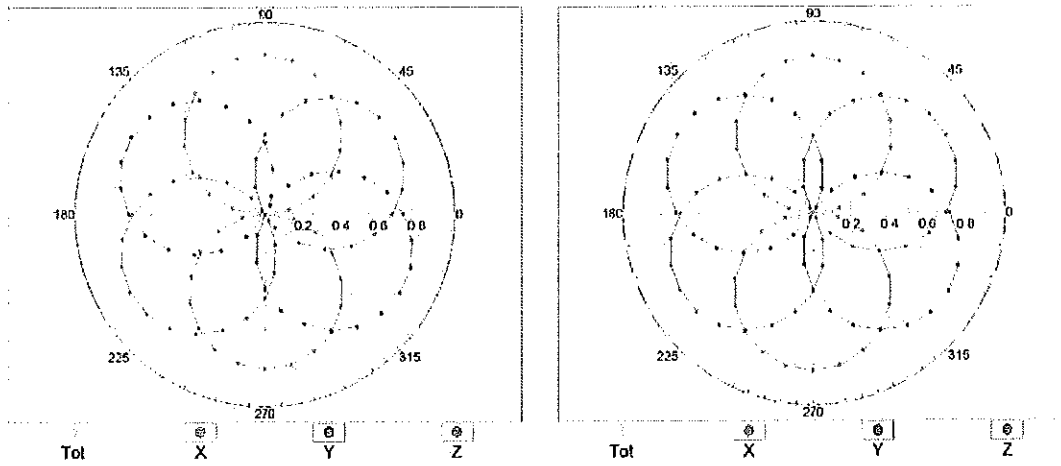

Uncertainty of Axial Isotropy Assessment: $\pm 0.5\%$ (k=2)

Dynamic Range $f(SAR_{head})$ (TEM cell, $f_{eval}=1900$ MHz)

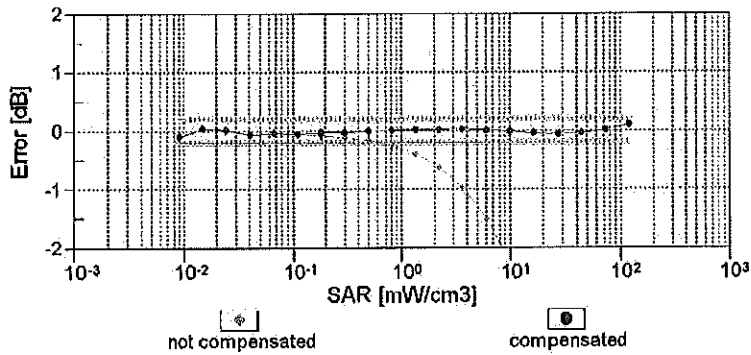
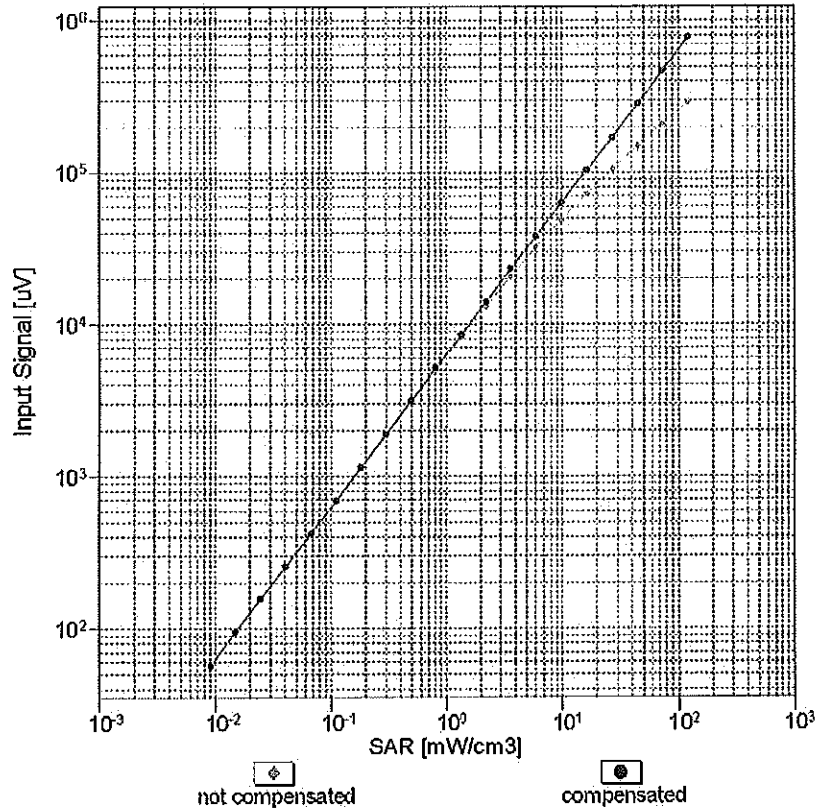

Uncertainty of Linearity Assessment: $\pm 0.6\%$ ($k=2$)

Conversion Factor Assessment

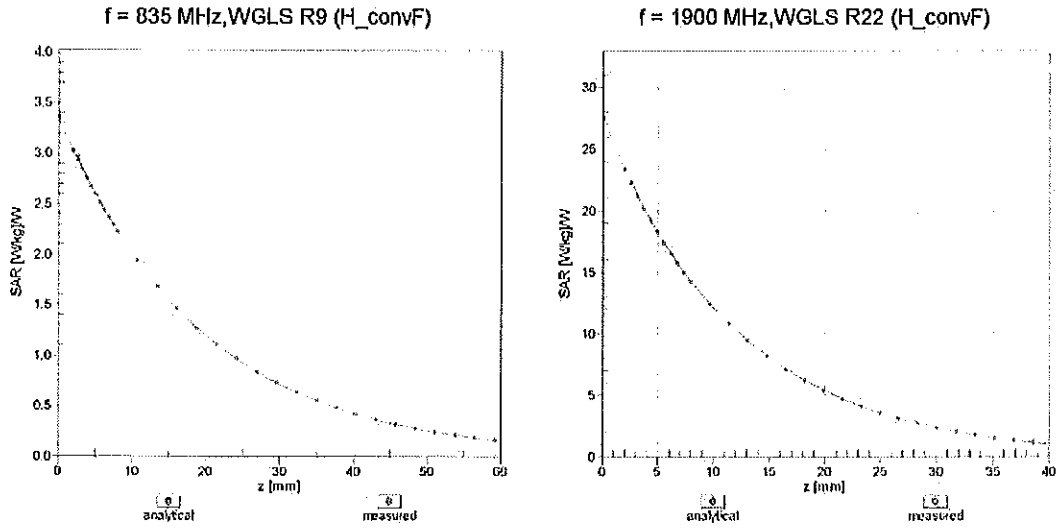

Deviation from Isotropy in Liquid Error (ϕ, θ), f = 900 MHz

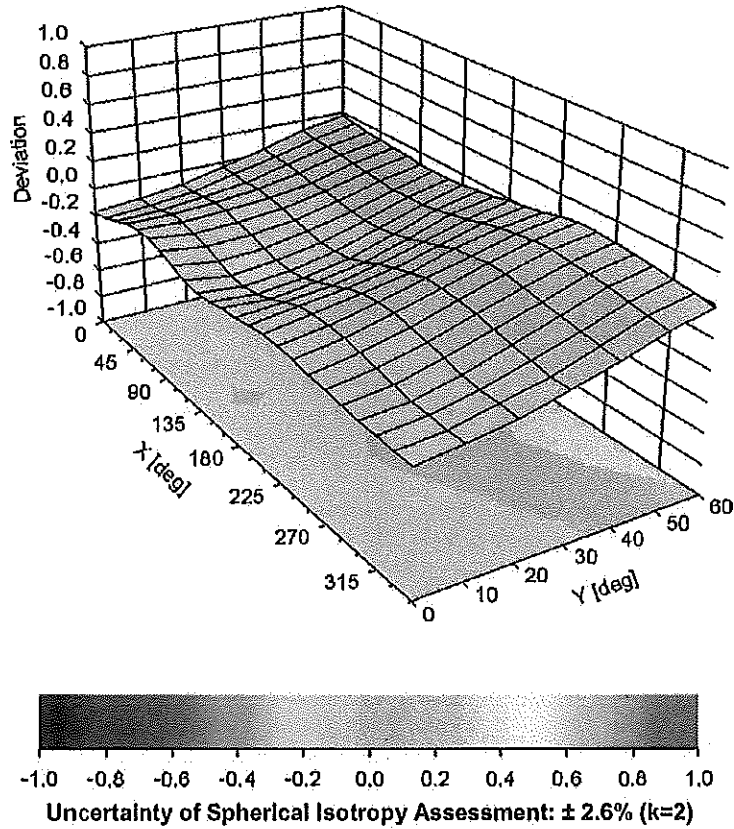

DASY/EASY - Parameters of Probe: ES3DV2 - SN:3022**Other Probe Parameters**

Sensor Arrangement	Triangular
Connector Angle (°)	-80,3
Mechanical Surface Detection Mode	enabled
Optical Surface Detection Mode	disabled
Probe Overall Length	337 mm
Probe Body Diameter	10 mm
Tip Length	10 mm
Tip Diameter	4 mm
Probe Tip to Sensor X Calibration Point	2 mm
Probe Tip to Sensor Y Calibration Point	2 mm
Probe Tip to Sensor Z Calibration Point	2 mm
Recommended Measurement Distance from Surface	3 mm



Accredited by the Swiss Accreditation Service (SAS)

Accreditation No.: **SCS 108**

The Swiss Accreditation Service is one of the signatories to the EA
Multilateral Agreement for the recognition of calibration certificates

Client **PC Test**

Certificate No: **ES3-3209_Mar14**

CALIBRATION CERTIFICATE

Object **ES3DV3 - SN:3209**

Calibration procedure(s) **QA CAL-01.v9, QA CAL-23.v5, QA CAL-25.v6
Calibration procedure for dosimetric E-field probes**

*CCV
3/27/14*

Calibration date: **March 19, 2014**

This calibration certificate documents the traceability to national standards, which realize the physical units of measurements (SI).
The measurements and the uncertainties with confidence probability are given on the following pages and are part of the certificate.

All calibrations have been conducted in the closed laboratory facility: environment temperature (22 ± 3)°C and humidity < 70%.

Calibration Equipment used (M&TE critical for calibration)

Primary Standards	ID	Cal Date (Certificate No.)	Scheduled Calibration
Power meter E4419B	GB41293874	04-Apr-13 (No. 217-01733)	Apr-14
Power sensor E4412A	MY41498087	04-Apr-13 (No. 217-01733)	Apr-14
Reference 3 dB Attenuator	SN: S5054 (3c)	04-Apr-13 (No. 217-01737)	Apr-14
Reference 20 dB Attenuator	SN: S5277 (20x)	04-Apr-13 (No. 217-01735)	Apr-14
Reference 30 dB Attenuator	SN: S5129 (30b)	04-Apr-13 (No. 217-01738)	Apr-14
Reference Probe ES3DV2	SN: 3013	30-Dec-13 (No. ES3-3013_Dec13)	Dec-14
DAE4	SN: 660	13-Dec-13 (No. DAE4-660_Dec13)	Dec-14
Secondary Standards	ID	Check Date (in house)	Scheduled Check
RF generator HP 8648C	US3642U01700	4-Aug-99 (in house check Apr-13)	In house check: Apr-16
Network Analyzer HP 8753E	US37390585	18-Oct-01 (in house check Oct-13)	In house check: Oct-14

Calibrated by:	Name Claudio Leubler	Function Laboratory Technician	Signature
Approved by:	Katja Pokovic	Technical Manager	
			Issued: March 20, 2014
This calibration certificate shall not be reproduced except in full without written approval of the laboratory.			



Accredited by the Swiss Accreditation Service (SAS)

Accreditation No.: **SCS 108**

The Swiss Accreditation Service is one of the signatories to the EA
Multilateral Agreement for the recognition of calibration certificates

Glossary:

TSL	tissue simulating liquid
NORM _{x,y,z}	sensitivity in free space
ConvF	sensitivity in TSL / NORM _{x,y,z}
DCP	diode compression point
CF	crest factor (1/duty_cycle) of the RF signal
A, B, C, D	modulation dependent linearization parameters
Polarization φ	φ rotation around probe axis
Polarization ϑ	ϑ rotation around an axis that is in the plane normal to probe axis (at measurement center), i.e., $\vartheta = 0$ is normal to probe axis
Connector Angle	information used in DASY system to align probe sensor X to the robot coordinate system

Calibration is Performed According to the Following Standards:

- IEEE Std 1528-2013, "IEEE Recommended Practice for Determining the Peak Spatial-Averaged Specific Absorption Rate (SAR) in the Human Head from Wireless Communications Devices: Measurement Techniques", June 2013
- IEC 62209-1, "Procedure to measure the Specific Absorption Rate (SAR) for hand-held devices used in close proximity to the ear (frequency range of 300 MHz to 3 GHz)", February 2005

Methods Applied and Interpretation of Parameters:

- NORM_{x,y,z}**: Assessed for E-field polarization $\vartheta = 0$ ($f \leq 900$ MHz in TEM-cell; $f > 1800$ MHz: R22 waveguide). NORM_{x,y,z} are only intermediate values, i.e., the uncertainties of NORM_{x,y,z} does not affect the E²-field uncertainty inside TSL (see below ConvF).
- NORM(f)_{x,y,z} = NORM_{x,y,z} * frequency_response** (see Frequency Response Chart). This linearization is implemented in DASY4 software versions later than 4.2. The uncertainty of the frequency response is included in the stated uncertainty of ConvF.
- DCP_{x,y,z}**: DCP are numerical linearization parameters assessed based on the data of power sweep with CW signal (no uncertainty required). DCP does not depend on frequency nor media.
- PAR**: PAR is the Peak to Average Ratio that is not calibrated but determined based on the signal characteristics
- A_{x,y,z}; B_{x,y,z}; C_{x,y,z}; D_{x,y,z}; VR_{x,y,z}; A, B, C, D** are numerical linearization parameters assessed based on the data of power sweep for specific modulation signal. The parameters do not depend on frequency nor media. VR is the maximum calibration range expressed in RMS voltage across the diode.
- ConvF and Boundary Effect Parameters**: Assessed in flat phantom using E-field (or Temperature Transfer Standard for $f \leq 800$ MHz) and inside waveguide using analytical field distributions based on power measurements for $f > 800$ MHz. The same setups are used for assessment of the parameters applied for boundary compensation (alpha, depth) of which typical uncertainty values are given. These parameters are used in DASY4 software to improve probe accuracy close to the boundary. The sensitivity in TSL corresponds to NORM_{x,y,z} * ConvF whereby the uncertainty corresponds to that given for ConvF. A frequency dependent ConvF is used in DASY version 4.4 and higher which allows extending the validity from ± 50 MHz to ± 100 MHz.
- Spherical isotropy (3D deviation from isotropy)**: in a field of low gradients realized using a flat phantom exposed by a patch antenna.
- Sensor Offset**: The sensor offset corresponds to the offset of virtual measurement center from the probe tip (on probe axis). No tolerance required.
- Connector Angle**: The angle is assessed using the information gained by determining the NORM_x (no uncertainty required).

Probe ES3DV3

SN:3209

Manufactured: October 14, 2008
Calibrated: March 19, 2014

Calibrated for DASY/EASY Systems
(Note: non-compatible with DASY2 system!)

DASY/EASY - Parameters of Probe: ES3DV3 - SN:3209

Basic Calibration Parameters

	Sensor X	Sensor Y	Sensor Z	Unc (k=2)
Norm ($\mu\text{V}/(\text{V}/\text{m})^2$) ^A	1.35	1.32	1.13	$\pm 10.1\%$
DCP (mV) ^B	101.5	101.0	102.5	

Modulation Calibration Parameters

UID	Communication System Name		A dB	B dB $\sqrt{\mu\text{V}}$	C	D dB	VR mV	Unc ^F (k=2)
0	CW	X	0.0	0.0	1.0	0.00	188.4	$\pm 3.8\%$
		Y	0.0	0.0	1.0		180.7	
		Z	0.0	0.0	1.0		200.1	
10010- CAA	SAR Validation (Square, 100ms, 10ms)	X	2.80	64.7	12.3	10.00	43.2	$\pm 1.4\%$
		Y	3.12	65.6	13.1		41.9	
		Z	2.67	64.0	11.7		39.4	
10011- CAB	UMTS-FDD (WCDMA)	X	3.39	67.7	19.0	2.91	149.2	$\pm 0.5\%$
		Y	3.38	67.7	19.0		146.1	
		Z	3.35	67.6	18.7		136.1	
10012- CAA	IEEE 802.11b WiFi 2.4 GHz (DSSS, 1 Mbps)	X	3.01	69.8	19.4	1.87	149.4	$\pm 0.7\%$
		Y	3.06	70.1	19.6		147.1	
		Z	2.98	69.7	19.2		136.4	
10021- DAB	GSM-FDD (TDMA, GMSK)	X	5.47	79.6	20.4	9.39	146.9	$\pm 1.7\%$
		Y	7.76	84.9	22.9		134.2	
		Z	4.34	75.3	18.5		134.2	
10023- DAB	GPRS-FDD (TDMA, GMSK, TN 0)	X	6.66	82.9	21.6	9.57	139.8	$\pm 2.5\%$
		Y	9.36	88.2	24.2		131.5	
		Z	4.67	76.1	18.8		144.8	
10024- DAB	GPRS-FDD (TDMA, GMSK, TN 0-1)	X	5.89	79.1	17.9	6.56	141.2	$\pm 1.9\%$
		Y	27.58	99.6	24.8		145.8	
		Z	5.42	77.8	17.4		129.3	
10027- DAB	GPRS-FDD (TDMA, GMSK, TN 0-1-2)	X	9.68	85.3	19.0	4.80	136.9	$\pm 2.2\%$
		Y	36.47	100.0	23.3		139.2	
		Z	31.63	96.5	21.4		149.2	
10028- DAB	GPRS-FDD (TDMA, GMSK, TN 0-1-2-3)	X	40.09	99.7	21.7	3.55	125.9	$\pm 1.9\%$
		Y	47.92	99.6	21.7		127.6	
		Z	61.98	99.9	20.8		136.2	
10032- CAA	IEEE 802.15.1 Bluetooth (GFSK, DH5)	X	99.32	95.7	16.5	1.16	145.1	$\pm 1.7\%$
		Y	55.30	99.5	19.3		145.6	
		Z	0.54	60.4	5.7		132.7	
10039- CAB	CDMA2000 (1xRTT, RC1)	X	4.77	67.1	19.2	4.57	145.6	$\pm 0.9\%$
		Y	4.85	67.5	19.5		147.8	
		Z	4.67	66.7	18.9		133.4	

10081-CAB	CDMA2000 (1xRTT, RC3)	X	3.93	66.4	18.8	3.97	140.9	±0.7 %
		Y	4.02	66.9	19.1		146.0	
		Z	3.86	66.1	18.5		129.1	
10098-CAB	UMTS-FDD (HSUPA, Subtest 2)	X	4.56	66.6	18.6	3.98	132.8	±0.7 %
		Y	4.58	66.7	18.7		135.9	
		Z	4.63	67.0	18.7		143.0	
10100-CAB	LTE-FDD (SC-FDMA, 100% RB, 20 MHz, QPSK)	X	6.42	67.5	19.8	5.67	139.3	±1.4 %
		Y	6.49	67.9	20.1		143.0	
		Z	6.18	66.7	19.3		126.9	
10108-CAB	LTE-FDD (SC-FDMA, 100% RB, 10 MHz, QPSK)	X	6.28	67.1	19.7	5.80	136.9	±1.4 %
		Y	6.35	67.5	20.0		140.4	
		Z	6.36	67.5	19.8		147.1	
10110-CAB	LTE-FDD (SC-FDMA, 100% RB, 5 MHz, QPSK)	X	5.94	66.5	19.4	5.75	134.0	±1.4 %
		Y	6.01	66.9	19.8		136.4	
		Z	5.99	66.8	19.5		143.6	
10114-CAA	IEEE 802.11n (HT Greenfield, 13.5 Mbps, BPSK)	X	10.02	68.5	21.1	8.10	127.2	±2.2 %
		Y	10.31	69.3	21.8		130.2	
		Z	10.12	68.8	21.2		139.0	
10117-CAA	IEEE 802.11n (HT Mixed, 13.5 Mbps, BPSK)	X	10.03	68.5	21.1	8.07	129.2	±2.2 %
		Y	10.31	69.3	21.7		131.2	
		Z	10.15	68.9	21.3		141.0	
10151-CAB	LTE-TDD (SC-FDMA, 50% RB, 20 MHz, QPSK)	X	8.54	72.4	24.8	9.28	139.6	±3.0 %
		Y	9.29	75.2	26.7		144.1	
		Z	8.55	72.5	24.7		149.7	
10154-CAB	LTE-FDD (SC-FDMA, 50% RB, 10 MHz, QPSK)	X	5.94	66.5	19.4	5.75	134.7	±1.4 %
		Y	6.00	66.9	19.7		136.7	
		Z	6.01	66.9	19.5		143.3	
10160-CAB	LTE-FDD (SC-FDMA, 50% RB, 15 MHz, QPSK)	X	6.40	67.1	19.7	5.82	139.9	±1.7 %
		Y	6.48	67.5	20.0		142.9	
		Z	6.43	67.3	19.7		148.7	
10169-CAB	LTE-FDD (SC-FDMA, 1 RB, 20 MHz, QPSK)	X	4.90	66.8	19.8	5.73	136.1	±1.4 %
		Y	5.03	67.2	20.2		141.1	
		Z	5.08	67.3	20.0		148.1	
10172-CAB	LTE-TDD (SC-FDMA, 1 RB, 20 MHz, QPSK)	X	6.56	72.5	25.2	9.21	125.7	±2.5 %
		Y	7.28	75.4	27.1		128.8	
		Z	6.78	73.0	25.2		138.3	
10175-CAB	LTE-FDD (SC-FDMA, 1 RB, 10 MHz, QPSK)	X	4.86	66.6	19.7	5.72	133.7	±1.4 %
		Y	4.97	66.9	20.0		136.3	
		Z	5.04	67.2	19.9		145.7	
10181-CAB	LTE-FDD (SC-FDMA, 1 RB, 15 MHz, QPSK)	X	4.88	66.7	19.7	5.72	133.3	±1.4 %
		Y	4.99	67.0	20.0		136.5	
		Z	5.06	67.3	19.9		145.7	

10193-CAA	IEEE 802.11n (HT Greenfield, 6.5 Mbps, BPSK)	X	10.05	69.2	21.7	8.09	146.7	±2.5 %
		Y	10.20	69.8	22.1		146.9	
		Z	9.76	68.5	21.1		132.1	
10196-CAA	IEEE 802.11n (HT Mixed, 6.5 Mbps, BPSK)	X	10.05	69.2	21.7	8.10	148.5	±2.2 %
		Y	10.21	69.9	22.2		148.0	
		Z	9.75	68.5	21.2		133.6	
10219-CAA	IEEE 802.11n (HT Mixed, 7.2 Mbps, BPSK)	X	9.96	69.2	21.6	8.03	148.9	±2.5 %
		Y	10.09	69.7	22.1		147.4	
		Z	9.67	68.5	21.1		133.4	
10222-CAA	IEEE 802.11n (HT Mixed, 15 Mbps, BPSK)	X	10.00	68.5	21.1	8.06	127.8	±2.2 %
		Y	10.21	69.1	21.6		127.3	
		Z	10.11	68.9	21.2		140.4	
10225-CAB	UMTS-FDD (HSPA+)	X	6.81	66.5	19.3	5.97	125.8	±1.4 %
		Y	7.07	67.5	19.9		149.0	
		Z	6.92	67.0	19.4		136.8	
10237-CAB	LTE-TDD (SC-FDMA, 1 RB, 10 MHz, QPSK)	X	6.62	72.8	25.3	9.21	128.5	±2.2 %
		Y	7.33	75.7	27.2		129.5	
		Z	6.87	73.4	25.5		141.8	
10252-CAB	LTE-TDD (SC-FDMA, 50% RB, 10 MHz, QPSK)	X	7.92	71.5	24.4	9.24	131.3	±3.0 %
		Y	8.35	73.3	25.7		131.3	
		Z	7.94	71.6	24.3		140.2	
10267-CAB	LTE-TDD (SC-FDMA, 100% RB, 10 MHz, QPSK)	X	8.52	72.3	24.8	9.30	138.8	±3.0 %
		Y	9.10	74.5	26.3		139.5	
		Z	8.53	72.3	24.6		149.4	
10274-CAB	UMTS-FDD (HSUPA, Subtest 5, 3GPP Rel8.10)	X	5.98	67.1	19.1	4.87	144.4	±0.9 %
		Y	5.99	67.3	19.2		144.0	
		Z	5.80	66.6	18.7		131.0	
10275-CAB	UMTS-FDD (HSUPA, Subtest 5, 3GPP Rel8.4)	X	4.51	67.2	19.0	3.96	148.6	±0.7 %
		Y	4.30	66.3	18.6		127.3	
		Z	4.40	66.9	18.7		135.9	
10291-AAB	CDMA2000, RC3, SO55, Full Rate	X	3.61	66.9	18.8	3.46	138.3	±0.7 %
		Y	3.67	67.2	19.0		140.5	
		Z	3.62	67.0	18.7		128.8	
10292-AAB	CDMA2000, RC3, SO32, Full Rate	X	3.59	67.1	18.9	3.39	141.5	±0.7 %
		Y	3.59	67.1	18.9		142.0	
		Z	3.59	67.2	18.8		130.8	
10297-AAA	LTE-FDD (SC-FDMA, 50% RB, 20 MHz, QPSK)	X	6.27	67.0	19.7	5.81	135.3	±1.7 %
		Y	6.31	67.3	19.9		136.0	
		Z	6.36	67.4	19.8		147.2	
10311-AAA	LTE-FDD (SC-FDMA, 100% RB, 15 MHz, QPSK)	X	6.91	67.9	20.2	6.06	141.9	±1.7 %
		Y	6.94	68.1	20.4		142.7	
		Z	6.68	67.1	19.7		130.3	

10315-AAA	IEEE 802.11b WiFi 2.4 GHz (DSSS, 1 Mbps, 96pc duty cycle)	X	2.94	69.9	19.6	1.71	148.6	±0.5 %
		Y	2.81	68.8	19.0		148.8	
		Z	2.92	69.7	19.2		138.1	
10403-AAB	CDMA2000 (1xEV-DO, Rev. 0)	X	4.76	68.7	19.1	3.76	128.0	±0.5 %
		Y	4.71	68.2	18.9		129.2	
		Z	4.85	68.8	19.0		141.9	
10404-AAB	CDMA2000 (1xEV-DO, Rev. A)	X	4.64	68.5	19.0	3.77	126.3	±0.7 %
		Y	4.60	68.2	18.9		127.9	
		Z	4.74	68.8	19.0		140.6	

The reported uncertainty of measurement is stated as the standard uncertainty of measurement multiplied by the coverage factor $k=2$, which for a normal distribution corresponds to a coverage probability of approximately 95%.

^A The uncertainties of NormX,Y,Z do not affect the E^2 -field uncertainty inside TSL (see Pages 8 and 9).

^B Numerical linearization parameter: uncertainty not required.

^E Uncertainty is determined using the max. deviation from linear response applying rectangular distribution and is expressed for the square of the field value.

DASY/EASY - Parameters of Probe: ES3DV3 - SN:3209

Calibration Parameter Determined in Head Tissue Simulating Media

f (MHz) ^C	Relative Permittivity ^F	Conductivity (S/m) ^F	ConvF X	ConvF Y	ConvF Z	Alpha ^G	Depth ^G (mm)	Unct. (k=2)
750	41.9	0.89	6.43	6.43	6.43	0.29	2.01	± 12.0 %
835	41.5	0.90	6.23	6.23	6.23	0.34	1.70	± 12.0 %
1750	40.1	1.37	5.24	5.24	5.24	0.80	1.13	± 12.0 %
1900	40.0	1.40	5.13	5.13	5.13	0.46	1.49	± 12.0 %
2450	39.2	1.80	4.54	4.54	4.54	0.63	1.38	± 12.0 %
2600	39.0	1.96	4.38	4.38	4.38	0.76	1.28	± 12.0 %

^C Frequency validity of ± 100 MHz only applies for DASY v4.4 and higher (see Page 2), else it is restricted to ± 50 MHz. The uncertainty is the RSS of the ConvF uncertainty at calibration frequency and the uncertainty for the indicated frequency band.

^F At frequencies below 3 GHz, the validity of tissue parameters (ϵ and σ) can be relaxed to ± 10% if liquid compensation formula is applied to measured SAR values. At frequencies above 3 GHz, the validity of tissue parameters (ϵ and σ) is restricted to ± 5%. The uncertainty is the RSS of the ConvF uncertainty for indicated target tissue parameters.

^G Alpha/Depth are determined during calibration. SPEAG warrants that the remaining deviation due to the boundary effect after compensation is always less than ± 1% for frequencies below 3 GHz and below ± 2% for frequencies between 3-6 GHz at any distance larger than half the probe tip diameter from the boundary.

DASY/EASY - Parameters of Probe: ES3DV3 - SN:3209

Calibration Parameter Determined in Body Tissue Simulating Media

f (MHz) ^C	Relative Permittivity ^F	Conductivity (S/m) ^F	ConvF X	ConvF Y	ConvF Z	Alpha ^G	Depth ^G (mm)	Unct. (k=2)
750	55.5	0.96	6.16	6.16	6.16	0.26	2.23	± 12.0 %
835	55.2	0.97	6.14	6.14	6.14	0.80	1.13	± 12.0 %
1750	53.4	1.49	4.85	4.85	4.85	0.59	1.42	± 12.0 %
1900	53.3	1.52	4.68	4.68	4.68	0.52	1.59	± 12.0 %
2450	52.7	1.95	4.20	4.20	4.20	0.73	1.08	± 12.0 %
2600	52.5	2.16	4.04	4.04	4.04	0.80	1.00	± 12.0 %

^C Frequency validity of ± 100 MHz only applies for DASY v4.4 and higher (see Page 2), else it is restricted to ± 50 MHz. The uncertainty is the RSS of the ConvF uncertainty at calibration frequency and the uncertainty for the indicated frequency band.

^F At frequencies below 3 GHz, the validity of tissue parameters (ϵ and σ) can be relaxed to ± 10% if liquid compensation formula is applied to measured SAR values. At frequencies above 3 GHz, the validity of tissue parameters (ϵ and σ) is restricted to ± 5%. The uncertainty is the RSS of the ConvF uncertainty for indicated target tissue parameters.

^G Alpha/Depth are determined during calibration. SPEAG warrants that the remaining deviation due to the boundary effect after compensation is always less than ± 1% for frequencies below 3 GHz and below ± 2% for frequencies between 3-6 GHz at any distance larger than half the probe tip diameter from the boundary.

Frequency Response of E-Field (TEM-Cell:ifi110 EXX, Waveguide: R22)

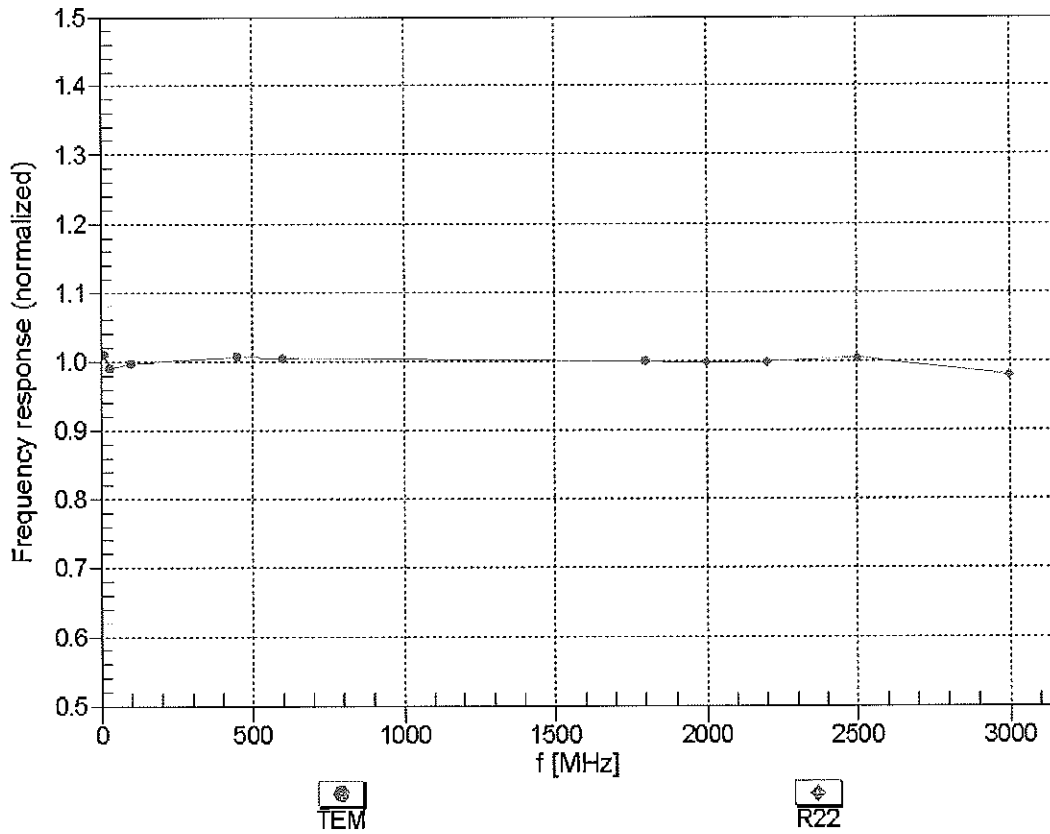

Uncertainty of Frequency Response of E-field: $\pm 6.3\%$ (k=2)

Receiving Pattern (ϕ), $\vartheta = 0^\circ$

f=600 MHz,TEM

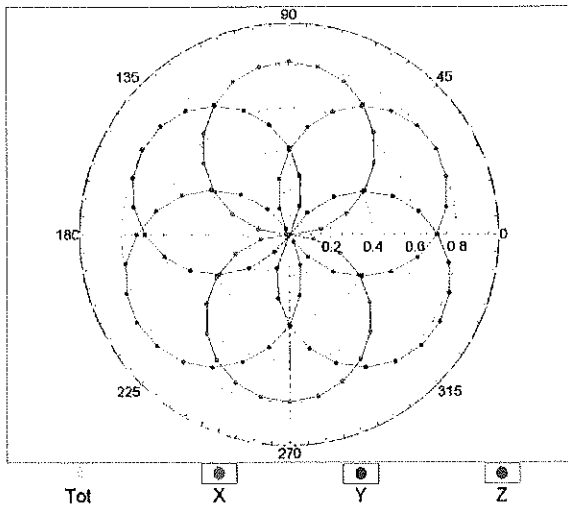

f=1800 MHz,R22

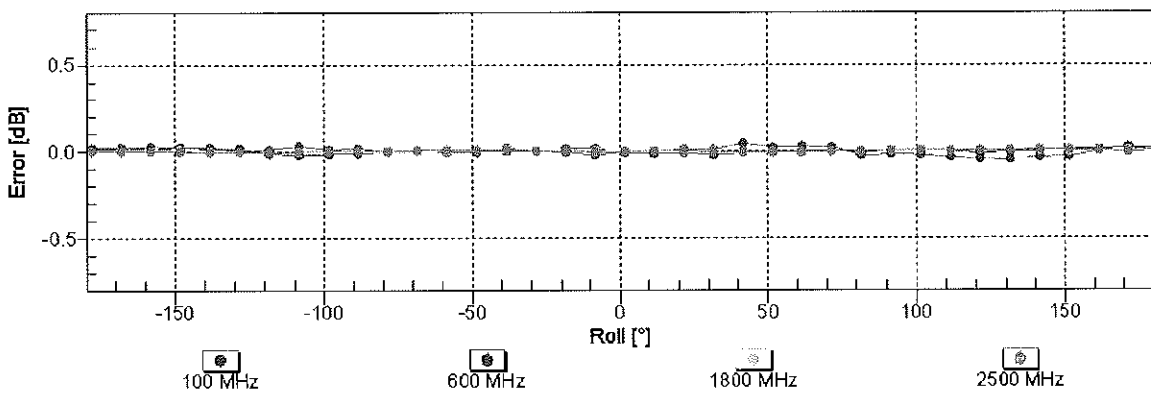
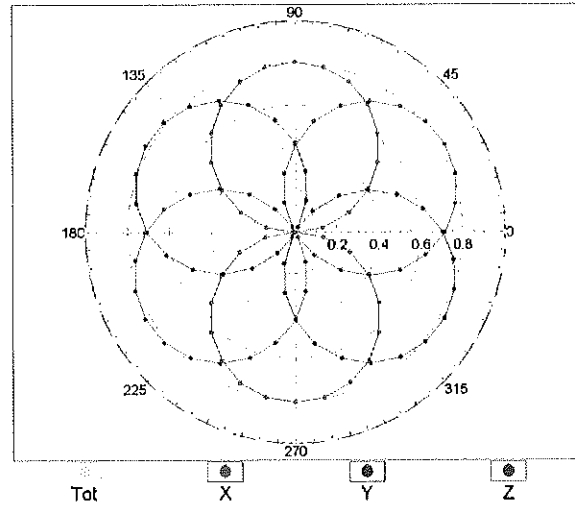

Uncertainty of Axial Isotropy Assessment: $\pm 0.5\%$ (k=2)

Dynamic Range $f(\text{SAR}_{\text{head}})$ (TEM cell , $f_{\text{eval}}= 1900 \text{ MHz}$)

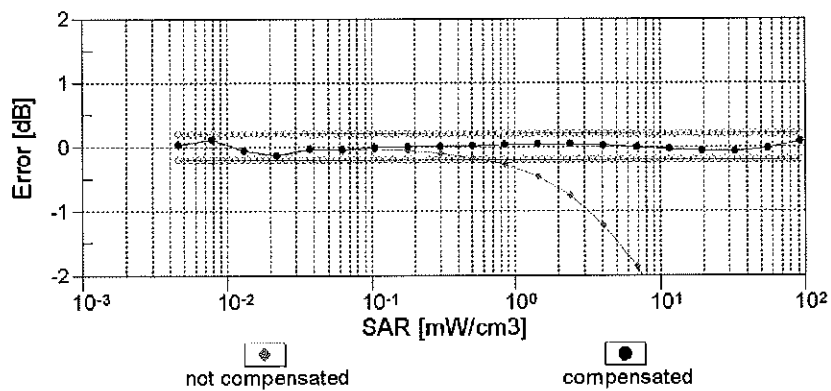
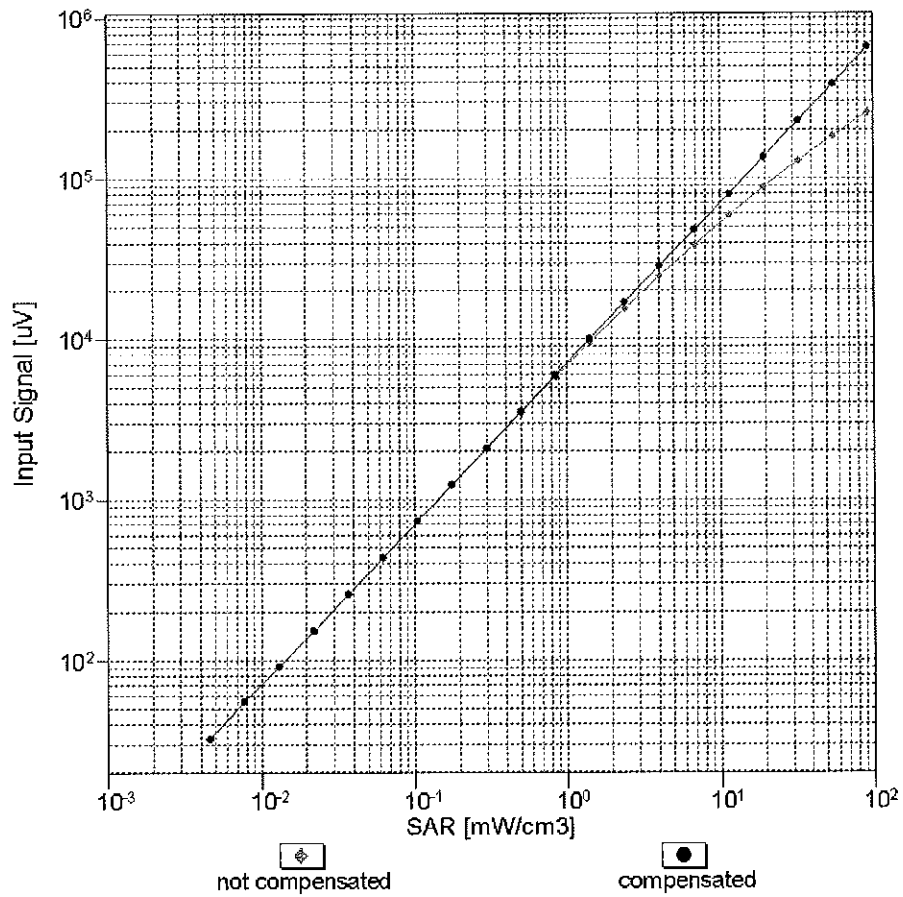

Uncertainty of Linearity Assessment: $\pm 0.6\%$ ($k=2$)

Conversion Factor Assessment

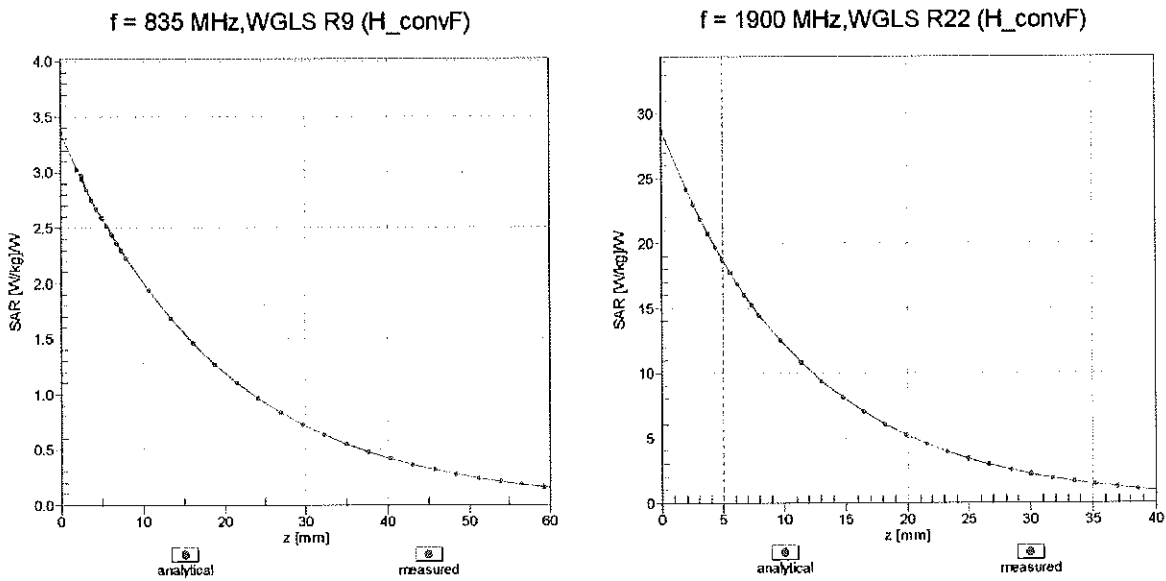

Deviation from Isotropy in Liquid Error (ϕ, θ), f = 900 MHz

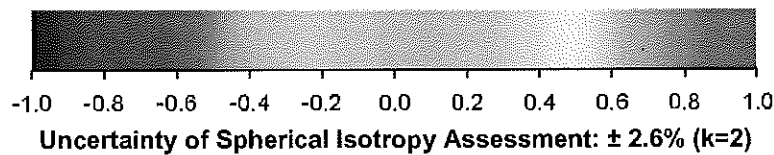
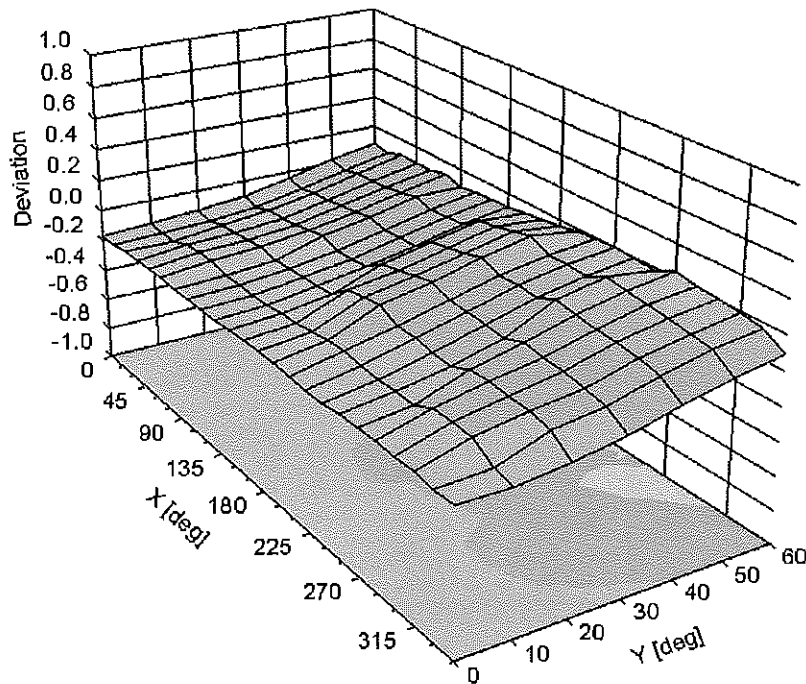

DASY/EASY - Parameters of Probe: ES3DV3 - SN:3209**Other Probe Parameters**

Sensor Arrangement	Triangular
Connector Angle (°)	-38.3
Mechanical Surface Detection Mode	enabled
Optical Surface Detection Mode	disabled
Probe Overall Length	337 mm
Probe Body Diameter	10 mm
Tip Length	10 mm
Tip Diameter	4 mm
Probe Tip to Sensor X Calibration Point	2 mm
Probe Tip to Sensor Y Calibration Point	2 mm
Probe Tip to Sensor Z Calibration Point	2 mm
Recommended Measurement Distance from Surface	3 mm

APPENDIX D: SAR TISSUE SPECIFICATIONS

Measurement Procedure for Tissue verification:



- 1) The network analyzer and probe system was configured and calibrated.
- 2) The probe was immersed in the tissue. The tissue was placed in a nonmetallic container. Trapped air bubbles beneath the flange were minimized by placing the probe at a slight angle.
- 3) The complex admittance with respect to the probe aperture was measured
- 4) The complex relative permittivity ϵ can be calculated from the below equation (Pournaropoulos and Misra):

$$Y = \frac{j2\omega\epsilon_r\epsilon_0}{[\ln(b/a)]^2} \int_a^b \int_a^b \int_0^\pi \cos\phi' \frac{\exp[-j\omega r(\mu_0\epsilon_r'\epsilon_0)^{1/2}]}{r} d\phi' d\rho' d\rho$$

where Y is the admittance of the probe in contact with the sample, the primed and unprimed coordinates refer to source and observation points, respectively, $r^2 = \rho^2 + \rho'^2 - 2\rho\rho' \cos\phi'$, ω is the angular frequency, and $j = \sqrt{-1}$.

Table D-I
Composition of the Tissue Equivalent Matter

Frequency (MHz)	750	835	1750	1900
Tissue	Body	Body	Body	Body
Ingredients (% by weight)				
Bactericide	See page 2	0.1		
DGBE			31	29.44
HEC		1		
NaCl		0.94	0.2	0.39
Sucrose		44.9		
Water		53.06	68.8	70.17

FCC ID: ACJ9TGWW13B	 PCTEST <small>ENGINEERING LABORATORY, INC.</small>	SAR EVALUATION REPORT		Reviewed by: Quality Manager
Test Dates: 12/15/14 - 01/08/15	DUT Type: Wireless Module			APPENDIX D: Page 1 of 2

2 Composition / Information on ingredients

The Item is composed of the following ingredients:

H ₂ O	Water, 35 – 58%
Sucrose	Sugar, white, refined, 40 – 60%
NaCl	Sodium Chloride, 0 – 6%
Hydroxyethyl-cellulose	Medium Viscosity (CAS# 9004-62-0), <0.3%
Preventol-D7	Preservative: aqueous preparation, (CAS# 55965-84-9), containing 5-chloro-2-methyl-3(2H)-isothiazolone and 2-methyl-3(2H)-isothiazolone, 0.1 – 0.7%

Relevant for safety; Refer to the respective Safety Data Sheet*.

Figure D-1
Composition of 750 MHz Body Tissue Equivalent Matter

Note: 750MHz liquid recipes are proprietary SPEAG. Since the composition is approximate to the actual liquids utilized, the manufacturer tissue-equivalent liquid data sheets are provided below.

Measurement Certificate / Material Test

Item Name	Body Tissue Simulating Liquid (MSL750V2)
Product No.	SL AAM 075 AA (Charge: 130828-1)
Manufacturer	SPEAG

Measurement Method

TSL dielectric parameters measured using calibrated OCP probe.

Setup Validation

Validation results were within $\pm 2.5\%$ towards the target values of Methanol.

Target Parameters

Target parameters as defined in the IEEE 1528 and IEC 62209 compliance standards.

Test Condition

Ambient	Environment temperatur (22 \pm 3) $^{\circ}$ C and humidity < 70%.
TSL Temperature	22 $^{\circ}$ C
Test Date	28-Aug-13
Operator	IEN

Additional Information

TSL Density	1.212 g/cm ³
TSL Heat-capacity	3.006 kJ/(kg*K)

f (MHz)	Measured			Target		Diff. to Target [%]	
	HP-e'	HP-e''	sigma	eps	sigma	Δ -eps	Δ -sigma
600	57.4	24.76	0.83	56.1	0.95	2.3	-13.2
625	57.1	24.42	0.85	56.0	0.95	2.0	-11.0
650	56.8	24.09	0.87	55.9	0.96	1.6	-8.9
675	56.6	23.80	0.89	55.8	0.96	1.3	-6.7
700	56.3	23.52	0.92	55.7	0.96	1.0	-4.5
725	56.1	23.27	0.94	55.6	0.96	0.8	-2.4
750	55.8	23.03	0.96	55.5	0.96	0.5	-0.3
775	55.6	22.87	0.99	55.4	0.97	0.2	2.1
800	55.3	22.71	1.01	55.3	0.97	-0.1	4.5
825	55.1	22.54	1.03	55.2	0.98	-0.3	5.8
838	54.9	22.45	1.05	55.2	0.98	-0.5	6.4
850	54.8	22.37	1.06	55.2	0.99	-0.6	7.0
875	54.6	22.25	1.08	55.1	1.02	-0.9	6.2
900	54.4	22.13	1.11	55.0	1.05	-1.1	5.5
925	54.2	22.02	1.13	55.0	1.06	-1.5	6.6
950	53.9	21.91	1.16	54.9	1.08	-1.8	7.7
975	53.7	21.84	1.18	54.9	1.09	-2.2	9.0
1000	53.5	21.77	1.21	54.8	1.10	-2.5	10.3

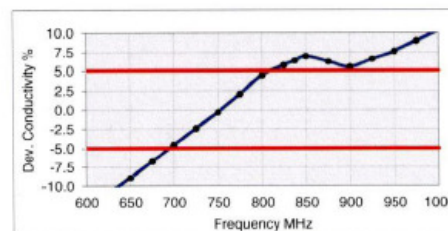
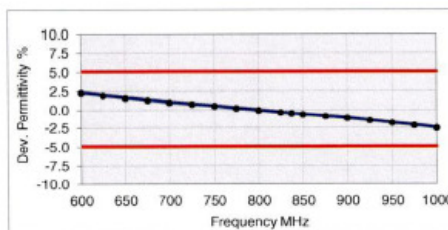



Figure D-2
750MHz Body Tissue Equivalent Matter

FCC ID: ACJ9TGWW13B		SAR EVALUATION REPORT		Reviewed by: Quality Manager
Test Dates: 12/15/14 - 01/08/15	DUT Type: Wireless Module			APPENDIX D: Page 2 of 2

APPENDIX E: SAR SYSTEM VALIDATION



Per FCC KDB 865664 D02v01, SAR system validation status should be documented to confirm measurement accuracy. The SAR systems (including SAR probes, system components and software versions) used for this device were validated against its performance specifications prior to the SAR measurements. Reference dipoles were used with the required tissue- equivalent media for system validation, according to the procedures outlined in FCC KDB 865664 D01 v01 and IEEE 1528-2013. Since SAR probe calibrations are frequency dependent, each probe calibration point was validated at a frequency within the valid frequency range of the probe calibration point, using the system that normally operates with the probe for routine SAR measurements and according to the required tissue-equivalent media.

A tabulated summary of the system validation status including the validation date(s), measurement frequencies, SAR probes and tissue dielectric parameters has been included.



Table E-I
SAR System Validation Summary

SAR SYSTEM #	FREQ. [MHz]	DATE	PROBE SN	PROBE TYPE	PROBE CAL. POINT		COND.	PERM.	CW VALIDATION			MOD. VALIDATION		
							(σ)	(ϵ_r)	SENSITIVITY	PROBE LINEARITY	PROBE ISOTROPY	MOD. TYPE	DUTY FACTOR	PAR
G	750	6/24/2014	3258	ES3DV3	750	Body	0.963	53.51	PASS	PASS	PASS	N/A	N/A	N/A
K	835	10/13/2014	3288	ES3DV3	835	Body	0.998	52.95	PASS	PASS	PASS	GMSK	PASS	N/A
G	1750	6/24/2014	3258	ES3DV3	1750	Body	1.454	51.74	PASS	PASS	PASS	N/A	N/A	N/A
J	1750	9/26/2014	3022	ES3DV2	1750	Body	1.471	51.49	PASS	PASS	PASS	N/A	N/A	N/A
G	1900	6/25/2014	3258	ES3DV3	1900	Body	1.534	51.23	PASS	PASS	PASS	GMSK	PASS	N/A
I	1900	6/26/2014	3209	ES3DV3	1900	Body	1.522	51.52	PASS	PASS	PASS	GMSK	PASS	N/A

NOTE: While the probes have been calibrated for both CW and modulated signals, all measurements were performed using communication systems calibrated for CW signals only. Modulations in the table above represent test configurations for which the measurement system has been validated per FCC KDB Publication 865664 D01v01 for scenarios when CW probe calibrations are used with other signal types. SAR systems were validated for modulated signals with a periodic duty cycle, such as GMSK according to KDB 865664.

FCC ID: ACJ9TGWW13B	 PCTEST ENGINEERING LABORATORY, INC.	SAR EVALUATION REPORT		Reviewed by: Quality Manager
Test Dates: 12/15/14 - 01/08/15	DUT Type: Wireless Module			APPENDIX E: Page 1 of 1

APPENDIX G: SENSOR TRIGGERING DATA SUMMARY



FCC ID: ACJ9TGWW13B	 PCTEST ENGINEERING LABORATORY, INC.	SAR EVALUATION REPORT		Reviewed by: Quality Manager
Test Dates: 12/15/14 - 01/08/15	DUT Type: Portable Tablet			APPENDIX G: Page 1 of 12

ACJ9TGWW13B Sensor Triggering Data Summary

Per FCC KDB Publication 616217 D04v01, this device was tested by the manufacturer to determine the proximity sensor triggering distances for the back and left edge of the device. The measured output power within ± 5 mm of the triggering points (or until touching the phantom) is included for back side and each applicable edge.

To ensure all production units are compliant it is necessary to test SAR at a distance 1 mm less than the smallest distance from the device and SAR phantom (determined from these triggering tests according to the KDB 616217 D04v01) with the device at maximum output power without power reduction. These SAR Tests are included in addition to the SAR tests for the device touching the SAR phantom, with reduced power.



The operational description contains information explaining how this device remains compliant in the event of a sensor malfunction.

FCC ID: ACJ9TGWW13B	 PCTEST ENGINEERING LABORATORY, INC.	SAR EVALUATION REPORT		Reviewed by: Quality Manager
Test Dates: 12/15/14 - 01/08/15	DUT Type: Portable Tablet			APPENDIX G: Page 2 of 12

Back Side

Moving device toward the phantom:



KDB 616217 §6.2.6 Measured Power [dBm]											
Distance [mm]	26	25	24	23	22	21	20	19	18	17	16
LTE Band 17	23.82	23.88	23.87	23.60	23.94	16.71	16.65	16.62	16.79	16.88	16.85
LTE Band 13	23.75	23.80	23.62	23.91	23.81	16.65	16.85	16.74	16.83	16.93	16.78
Distance [mm]	24	23	22	21	20	19	18	17	16	15	14
GSM 850 GMSK ITX	33.39	33.23	33.30	33.30	33.43	26.15	26.35	26.16	26.23	26.43	26.14
GSM 850 GMSK 2TX	33.24	33.28	33.12	33.45	33.32	24.89	24.65	24.78	24.90	24.83	24.87
GSM 850 8PSK ITX	27.95	27.65	27.61	27.68	27.68	25.10	25.20	25.10	25.36	25.32	25.28
GSM 850 8PSK 2TX	27.63	27.65	27.69	27.76	27.66	24.44	24.31	24.32	24.36	24.38	24.44
GSM 850 8PSK 3TX	27.62	27.60	27.85	27.68	27.82	22.38	22.17	22.22	22.29	22.27	22.40
GSM 850 8PSK 4TX	27.80	27.90	27.77	27.77	27.84	21.43	21.20	21.19	21.18	21.39	21.32
UMTS Band 5 Rel99	23.89	23.95	23.78	23.91	23.69	17.18	17.32	17.35	17.27	17.37	17.29
UMTS Band 5 HSDPA	22.79	22.65	22.77	22.70	22.67	16.76	16.68	16.88	16.67	16.61	16.75
UMTS Band 5 HSUPA	22.89	22.67	22.69	22.90	22.78	16.93	16.73	16.61	16.61	16.80	16.94
UMTS Band 5 DC-HSDPA	22.84	22.81	22.74	22.92	22.63	16.93	16.64	16.62	16.64	16.68	16.88
CDMA BC10	24.62	24.88	24.92	24.60	24.72	17.75	17.76	17.80	17.67	17.86	17.68
CDMA BC0	24.77	24.77	24.74	24.73	24.69	17.94	17.81	17.86	17.92	17.88	17.62
LTE Band 5	23.61	23.62	23.64	23.91	23.87	16.66	16.77	16.86	16.69	16.95	16.93
Distance [mm]	28	27	26	25	24	23	22	21	20	19	18
GSM 1900 GMSK ITX	30.34	30.15	30.32	30.28	30.45	20.21	20.41	20.37	20.30	20.25	20.37
GSM 1900 GMSK 2TX	30.39	30.34	30.41	30.18	30.31	17.79	17.85	17.91	17.63	17.66	17.93
GSM 1900 8PSK ITX	26.79	26.68	26.83	26.83	26.94	20.74	20.76	20.80	20.82	20.83	20.84
GSM 1900 8PSK 2TX	26.84	26.87	26.83	26.93	26.72	17.18	17.12	17.30	17.25	17.16	17.16
GSM 1900 8PSK 3TX	26.86	26.86	26.63	26.70	26.83	15.38	15.16	15.41	15.19	15.35	15.14
GSM 1900 8PSK 4TX	26.92	26.84	26.82	26.69	26.88	14.17	14.43	14.40	14.21	14.14	14.10
UMTS Band 4 Rel99	23.93	23.68	23.95	23.86	23.93	9.91	9.76	9.89	9.81	9.80	9.95
UMTS Band 4 HSDPA	22.67	22.95	22.64	22.67	22.89	9.11	9.24	9.26	9.30	9.20	9.19
UMTS Band 4 HSUPA	22.80	22.87	22.70	22.75	22.68	9.40	9.26	9.17	9.24	9.34	9.44
UMTS Band 4 DC-HSDPA	22.60	22.70	22.68	22.81	22.92	9.24	9.30	9.42	9.15	9.14	9.29
UMTS Band 2 Rel99	23.68	23.86	23.84	23.85	23.66	11.14	11.18	11.34	11.18	11.32	11.43
UMTS Band 2 HSDPA	22.66	22.89	22.78	22.63	22.70	11.15	11.16	11.31	11.15	11.42	11.24
UMTS Band 2 HSUPA	22.87	22.60	22.74	22.91	22.67	11.25	11.39	11.34	11.22	11.35	11.16
UMTS Band 2 DC-HSDPA	22.71	22.74	22.71	22.62	22.61	11.41	11.13	11.19	11.26	11.28	11.24
CDMA BC1	24.88	24.69	24.90	24.63	24.67	11.32	11.11	11.28	11.16	11.11	11.44
LTE Band 4	23.62	23.81	23.89	23.64	23.64	10.73	10.84	10.72	10.73	10.61	10.61
LTE Band 2	23.81	23.92	23.95	23.76	23.81	11.62	11.93	11.65	11.92	11.80	11.76
LTE Band 25	23.92	23.87	23.60	23.75	23.76	11.75	11.70	11.82	11.67	11.87	11.85

FCC ID: ACJ9TGWW13B	 PCTEST ENGINEERING LABORATORY, INC.	SAR EVALUATION REPORT	 Panasonic	Reviewed by: Quality Manager
Test Dates: 12/15/14 - 01/08/15	DUT Type: Portable Tablet	APPENDIX G: Page 3 of 12		

Moving device away from the phantom:

KDB 616217 §6.2.8 Measured Power [dBm]											
Distance [mm]	45	46	47	48	49	50	51	52	53	54	55
LTE Band 17	16.68	16.66	16.82	16.94	16.78	16.83	23.73	23.60	23.87	23.94	23.63
LTE Band 13	16.86	16.87	16.81	16.77	16.90	16.90	23.83	23.95	23.60	23.76	23.75
Distance [mm]	45	46	47	48	49	50	51	52	53	54	55
GSM 850 GMSK ITX	26.36	26.11	26.42	26.16	26.27	26.11	33.43	33.26	33.33	33.17	33.23
GSM 850 GMSK 2TX	24.67	24.81	24.61	24.71	24.75	24.79	33.25	33.36	33.36	33.20	33.35
GSM 850 8PSK ITX	25.13	25.41	25.23	25.20	25.34	25.21	27.80	27.63	27.64	27.67	27.63
GSM 850 8PSK 2TX	24.23	24.37	24.25	24.26	24.30	24.11	27.64	27.79	27.95	27.90	27.90
GSM 850 8PSK 3TX	22.13	22.27	22.21	22.11	22.18	22.41	27.88	27.78	27.70	27.77	27.82
GSM 850 8PSK 4TX	21.31	21.44	21.45	21.21	21.34	21.14	27.91	27.95	27.63	27.64	27.79
UMTS Band 5 Re199	17.26	17.29	17.25	17.16	17.17	17.19	23.60	23.93	23.62	23.72	23.84
UMTS Band 5 HSDPA	16.92	16.71	16.69	16.89	16.74	16.63	22.82	22.80	22.86	22.73	22.87
UMTS Band 5 HSUPA	16.64	16.71	16.68	16.83	16.87	16.90	22.63	22.68	22.87	22.70	22.60
UMTS Band 5 DC-HSDPA	16.66	16.84	16.90	16.66	16.61	16.79	22.62	22.88	22.79	22.88	22.76
CDMA BC10	17.94	17.79	17.92	17.61	17.80	17.67	24.68	24.85	24.94	24.76	24.91
CDMA BC0	17.64	17.78	17.80	17.87	17.94	17.87	24.92	24.91	24.67	24.61	24.66
LTE Band 5	16.70	16.66	16.87	16.90	16.92	16.66	23.64	23.78	23.90	23.80	23.95
Distance [mm]	55	56	57	58	59	60	61	62	63	64	65
GSM 1900 GMSK ITX	20.14	20.13	20.16	20.43	20.44	20.12	30.36	30.41	30.31	30.28	30.24
GSM 1900 GMSK 2TX	17.87	17.85	17.61	17.70	17.73	17.67	30.19	30.16	30.14	30.36	30.12
GSM 1900 8PSK ITX	20.86	20.73	20.65	20.65	20.91	20.82	26.63	26.79	26.66	26.74	26.83
GSM 1900 8PSK 2TX	17.25	17.12	17.12	17.27	17.12	17.37	26.64	26.76	26.80	26.74	26.61
GSM 1900 8PSK 3TX	15.41	15.21	15.42	15.43	15.19	15.11	26.79	26.71	26.79	26.94	26.90
GSM 1900 8PSK 4TX	14.42	14.43	14.11	14.30	14.42	14.38	26.81	26.90	26.87	26.65	26.94
UMTS Band 4 Re199	9.85	9.70	9.84	9.67	9.64	9.80	23.76	23.73	23.86	23.91	23.83
UMTS Band 4 HSDPA	9.15	9.11	9.28	9.11	9.33	9.23	22.88	22.87	22.67	22.69	22.83
UMTS Band 4 HSUPA	9.42	9.38	9.38	9.10	9.31	9.24	22.62	22.91	22.87	22.68	22.63
UMTS Band 4 DC-HSDPA	9.23	9.33	9.21	9.35	9.17	9.26	22.80	22.84	22.74	22.75	22.63
UMTS Band 2 Re199	11.38	11.29	11.40	11.31	11.15	11.23	23.74	23.90	23.66	23.78	23.90
UMTS Band 2 HSDPA	11.39	11.10	11.44	11.18	11.12	11.15	22.91	22.69	22.65	22.63	22.78
UMTS Band 2 HSUPA	11.23	11.29	11.41	11.17	11.15	11.17	22.86	22.85	22.83	22.90	22.66
UMTS Band 2 DC-HSDPA	11.36	11.13	11.44	11.38	11.32	11.12	22.77	22.84	22.78	22.95	22.73
CDMA BC1	11.21	11.45	11.43	11.15	11.28	11.35	24.92	24.67	24.69	24.75	24.95
LTE Band 4	10.66	10.62	10.75	10.60	10.77	10.73	23.67	23.61	23.89	23.81	23.67
LTE Band 2	11.92	11.89	11.61	11.61	11.71	11.80	23.71	23.81	23.76	23.71	23.61
LTE Band 25	11.69	11.71	11.82	11.60	11.92	11.94	23.61	23.62	23.82	23.67	23.82



Based on the most conservative measured triggering distance of 19 mm for all modes, additional SAR measurements were required at 18 mm from the back side.

FCC ID: ACJ9TGWW13B	 PCTEST ENGINEERING LABORATORY, INC.	SAR EVALUATION REPORT		Reviewed by: Quality Manager
Test Dates: 12/15/14 - 01/08/15	DUT Type: Portable Tablet			APPENDIX G: Page 4 of 12

Right Edge

Moving device toward the phantom:



KDB 616217 §6.2.6 Measured Power [dBm]											
Distance [mm]	9	8	7	6	5	4	3	2	1	0	N/A
LTE Band 17	23.72	23.63	23.62	23.74	23.62	16.77	16.68	16.94	16.75	16.93	N/A
LTE Band 13	23.71	23.72	23.89	23.76	23.82	16.88	16.64	16.66	16.61	16.67	N/A
Distance [mm]	9	8	7	6	5	4	3	2	1	0	N/A
GSM 850 GMSK ITX	33.37	33.19	33.42	33.22	33.21	26.25	26.34	26.14	26.36	26.42	N/A
GSM 850 GMSK 2TX	33.10	33.39	33.44	33.26	33.45	24.93	24.65	24.88	24.72	24.63	N/A
GSM 850 8PSK ITX	27.72	27.85	27.66	27.79	27.87	25.10	25.15	25.14	25.10	25.15	N/A
GSM 850 8PSK 2TX	27.72	27.86	27.92	27.64	27.73	24.24	24.19	24.29	24.28	24.21	N/A
GSM 850 8PSK 3TX	27.63	27.87	27.62	27.71	27.65	22.10	22.16	22.32	22.38	22.35	N/A
GSM 850 8PSK 4TX	27.83	27.75	27.65	27.91	27.88	21.45	21.39	21.39	21.42	21.16	N/A
UMTS Band 5 Rel99	23.94	23.65	23.86	23.85	23.83	17.43	17.43	17.44	17.23	17.15	N/A
UMTS Band 5 HSDPA	22.87	22.79	22.69	22.87	22.72	16.94	16.81	16.75	16.85	16.80	N/A
UMTS Band 5 HSUPA	22.71	22.95	22.85	22.69	22.83	16.74	16.68	16.83	16.70	16.67	N/A
UMTS Band 5 DC-HSDPA	22.75	22.93	22.75	22.75	22.69	16.90	16.61	16.84	16.79	16.73	N/A
CDMA BC10	24.93	24.69	24.66	24.66	24.68	17.66	17.72	17.73	17.78	17.94	N/A
CDMA BC0	24.80	24.90	24.79	24.76	24.77	17.63	17.79	17.94	17.83	17.64	N/A
LTE Band 5	23.74	23.79	23.87	23.85	23.71	16.82	16.63	16.89	16.86	16.79	N/A
Distance [mm]	10	9	8	7	6	5	4	3	2	1	0
GSM 1900 GMSK ITX	30.13	30.39	30.29	30.45	30.27	20.40	20.39	20.11	20.45	20.31	20.38
GSM 1900 GMSK 2TX	30.24	30.45	30.12	30.16	30.32	17.86	17.94	17.94	17.89	17.74	17.63
GSM 1900 8PSK ITX	26.81	26.80	26.66	26.66	26.93	20.66	20.67	20.85	20.92	20.73	20.86
GSM 1900 8PSK 2TX	26.61	26.68	26.69	26.90	26.87	17.44	17.39	17.18	17.10	17.42	17.30
GSM 1900 8PSK 3TX	26.65	26.84	26.63	26.91	26.66	15.31	15.26	15.17	15.42	15.25	15.45
GSM 1900 8PSK 4TX	26.88	26.80	26.88	26.91	26.68	14.43	14.44	14.38	14.15	14.33	14.17
UMTS Band 4 Rel99	23.93	23.93	23.66	23.82	23.68	9.72	9.73	9.74	9.64	9.88	9.72
UMTS Band 4 HSDPA	22.77	22.94	22.94	22.78	22.83	9.19	9.18	9.14	9.33	9.34	9.20
UMTS Band 4 HSUPA	22.82	22.92	22.76	22.61	22.87	9.41	9.32	9.27	9.40	9.34	9.45
UMTS Band 4 DC-HSDPA	22.77	22.69	22.68	22.71	22.92	9.30	9.12	9.21	9.36	9.21	9.10
UMTS Band 2 Rel99	23.73	23.68	23.77	23.78	23.69	11.41	11.30	11.18	11.22	11.33	11.33
UMTS Band 2 HSDPA	22.79	22.86	22.61	22.69	22.74	11.34	11.34	11.35	11.15	11.33	11.23
UMTS Band 2 HSUPA	22.95	22.83	22.88	22.92	22.81	11.22	11.38	11.31	11.10	11.10	11.30
UMTS Band 2 DC-HSDPA	22.93	22.88	22.88	22.77	22.93	11.16	11.38	11.29	11.30	11.11	11.12
CDMA BC1	24.94	24.93	24.84	24.89	24.73	11.42	11.34	11.11	11.24	11.15	11.20
LTE Band 4	23.80	23.90	23.84	23.77	23.75	10.61	10.64	10.63	10.90	10.72	10.74
LTE Band 2	23.84	23.66	23.85	23.76	23.76	11.75	11.64	11.79	11.90	11.93	11.75
LTE Band 25	23.70	23.60	23.75	23.87	23.74	11.92	11.67	11.67	11.69	11.90	11.82

FCC ID: ACJ9TGWW13B	 PCTEST ENGINEERING LABORATORY, INC.	SAR EVALUATION REPORT	 Panasonic	Reviewed by: Quality Manager
Test Dates: 12/15/14 - 01/08/15	DUT Type: Portable Tablet	APPENDIX G: Page 5 of 12		

Moving device away from the phantom:

KDB 616217 §6.2.8 Measured Power [dBm]											
Distance [mm]	20	21	22	23	24	25	26	27	28	29	30
LTE Band 17	16.68	16.68	16.60	16.91	16.92	16.69	23.95	23.76	23.87	23.92	23.95
LTE Band 13	16.81	16.63	16.72	16.95	16.60	16.64	23.76	23.74	23.62	23.66	23.86
Distance [mm]	30	31	32	33	34	35	36	37	38	39	40
GSM 850 GMSK ITX	26.20	26.31	26.32	26.44	26.33	26.39	33.12	33.32	33.12	33.44	33.42
GSM 850 GMSK 2TX	24.80	24.63	24.65	24.76	24.67	24.74	33.11	33.34	33.26	33.38	33.20
GSM 850 8PSK ITX	25.28	25.40	25.38	25.18	25.14	25.33	27.81	27.85	27.62	27.80	27.77
GSM 850 8PSK 2TX	24.36	24.36	24.33	24.24	24.40	24.16	27.69	27.89	27.86	27.65	27.85
GSM 850 8PSK 3TX	22.10	22.42	22.39	22.37	22.39	22.20	27.61	27.86	27.71	27.93	27.66
GSM 850 8PSK 4TX	21.10	21.31	21.34	21.21	21.40	21.21	27.69	27.93	27.65	27.76	27.72
UMTS Band 5 Re199	17.30	17.32	17.23	17.30	17.22	17.38	23.81	23.62	23.62	23.93	23.90
UMTS Band 5 HSDPA	16.67	16.83	16.70	16.61	16.82	16.85	22.75	22.75	22.62	22.89	22.82
UMTS Band 5 HSUPA	16.78	16.69	16.73	16.84	16.86	16.90	22.73	22.66	22.73	22.71	22.84
UMTS Band 5 DC-HSDPA	16.94	16.84	16.84	16.95	16.85	16.67	22.73	22.82	22.73	22.61	22.77
CDMA BC10	17.95	17.71	17.95	17.62	17.73	17.72	24.72	24.71	24.86	24.63	24.70
CDMA BC0	17.81	17.74	17.77	17.62	17.84	17.82	24.71	24.82	24.63	24.77	24.70
LTE Band 5	16.71	16.84	16.75	16.91	16.68	16.67	23.67	23.95	23.93	23.93	23.88
Distance [mm]	8	9	10	11	12	13	14	15	16	17	18
GSM 1900 GMSK ITX	20.35	20.27	20.44	20.35	20.15	20.31	30.27	30.44	30.23	30.35	30.22
GSM 1900 GMSK 2TX	17.78	17.71	17.76	17.82	17.76	17.89	30.13	30.34	30.19	30.27	30.11
GSM 1900 8PSK ITX	20.87	20.68	20.89	20.85	20.72	20.93	26.64	26.88	26.71	26.84	26.65
GSM 1900 8PSK 2TX	17.16	17.44	17.14	17.36	17.41	17.30	26.65	26.68	26.91	26.86	26.62
GSM 1900 8PSK 3TX	15.25	15.38	15.15	15.37	15.15	15.15	26.69	26.82	26.72	26.82	26.83
GSM 1900 8PSK 4TX	14.43	14.18	14.33	14.10	14.37	14.10	26.66	26.65	26.91	26.73	26.61
UMTS Band 4 Re199	9.80	9.64	9.73	9.82	9.90	9.93	23.81	23.72	23.73	23.74	23.65
UMTS Band 4 HSDPA	9.23	9.13	9.24	9.19	9.19	9.44	22.63	22.90	22.80	22.76	22.88
UMTS Band 4 HSUPA	9.29	9.42	9.11	9.17	9.16	9.13	22.92	22.87	22.65	22.95	22.78
UMTS Band 4 DC-HSDPA	9.16	9.18	9.20	9.32	9.37	9.30	22.94	22.79	22.62	22.78	22.77
UMTS Band 2 Re199	11.28	11.29	11.17	11.30	11.16	11.40	23.62	23.79	23.80	23.79	23.69
UMTS Band 2 HSDPA	11.11	11.13	11.35	11.36	11.13	11.38	22.93	22.78	22.89	22.62	22.82
UMTS Band 2 HSUPA	11.43	11.29	11.30	11.34	11.13	11.10	22.72	22.84	22.67	22.80	22.82
UMTS Band 2 DC-HSDPA	11.40	11.32	11.32	11.38	11.41	11.32	22.63	22.81	22.63	22.79	22.61
CDMA BC1	11.14	11.42	11.10	11.30	11.30	11.20	24.66	24.88	24.70	24.81	24.89
LTE Band 4	10.74	10.64	10.78	10.91	10.67	10.90	23.67	23.85	23.83	23.61	23.95
LTE Band 2	11.70	11.63	11.84	11.63	11.78	11.81	23.68	23.73	23.93	23.66	23.60
LTE Band 25	11.74	11.77	11.75	11.78	11.73	11.88	23.65	23.88	23.63	23.61	23.68



Based on the most conservative measured triggering distance of 4 mm for all modes, additional SAR measurements were required at 3 mm from the right edge.

FCC ID: ACJ9TGWW13B	 PCTEST ENGINEERING LABORATORY, INC.	SAR EVALUATION REPORT		Reviewed by: Quality Manager
Test Dates: 12/15/14 - 01/08/15	DUT Type: Portable Tablet			APPENDIX G: Page 6 of 12

Right Edge - Tilt

Moving device toward the phantom:



KDB 616217 §6.2.6 Measured Power [dBm]											
Distance [mm]	9	8	7	6	5	4	3	2	1	0	N/A
LTE Band 17	23.92	23.72	23.87	23.68	23.67	16.90	16.72	16.60	16.93	16.94	N/A
LTE Band 13	23.87	23.84	23.68	23.69	23.61	16.70	16.75	16.80	16.93	16.83	N/A
Distance [mm]	9	8	7	6	5	4	3	2	1	0	N/A
GSM 850 GMSK ITX	33.36	33.45	33.35	33.15	33.44	26.17	26.10	26.26	26.24	26.37	N/A
GSM 850 GMSK 2TX	33.12	33.27	33.16	33.25	33.11	24.66	24.73	24.94	24.94	24.75	N/A
GSM 850 8PSK ITX	27.93	27.77	27.79	27.76	27.69	25.16	25.39	25.37	25.24	25.21	N/A
GSM 850 8PSK 2TX	27.78	27.90	27.65	27.73	27.81	24.28	24.35	24.24	24.23	24.29	N/A
GSM 850 8PSK 3TX	27.88	27.70	27.93	27.90	27.76	22.32	22.33	22.11	22.32	22.44	N/A
GSM 850 8PSK 4TX	27.88	27.60	27.72	27.80	27.64	21.42	21.44	21.13	21.20	21.38	N/A
UMTS Band 5 Rel99	23.60	23.84	23.65	23.77	23.92	17.34	17.28	17.12	17.41	17.45	N/A
UMTS Band 5 HSDPA	22.68	22.77	22.90	22.69	22.64	16.68	16.77	16.85	16.63	16.90	N/A
UMTS Band 5 HSUPA	22.86	22.80	22.72	22.64	22.74	16.95	16.80	16.60	16.71	16.81	N/A
UMTS Band 5 DC-HSDPA	22.79	22.92	22.75	22.81	22.86	16.70	16.64	16.78	16.79	16.86	N/A
CDMA BC10	24.78	24.66	24.93	24.90	24.70	17.80	17.95	17.82	17.68	17.89	N/A
CDMA BC0	24.86	24.65	24.62	24.84	24.80	17.72	17.61	17.70	17.69	17.68	N/A
LTE Band 5	23.76	23.92	23.83	23.71	23.74	16.73	16.78	16.86	16.91	16.78	N/A
Distance [mm]	10	9	8	7	6	5	4	3	2	1	0
GSM 1900 GMSK ITX	30.26	30.37	30.32	30.11	30.29	20.40	20.38	20.33	20.15	20.25	20.39
GSM 1900 GMSK 2TX	30.45	30.24	30.32	30.28	30.30	17.93	17.92	17.95	17.72	17.87	17.74
GSM 1900 8PSK ITX	26.95	26.80	26.95	26.75	26.95	20.93	20.90	20.66	20.87	20.78	20.75
GSM 1900 8PSK 2TX	26.71	26.77	26.71	26.66	26.65	17.28	17.32	17.44	17.43	17.17	17.44
GSM 1900 8PSK 3TX	26.87	26.60	26.73	26.70	26.75	15.42	15.17	15.17	15.38	15.30	15.37
GSM 1900 8PSK 4TX	26.81	26.71	26.73	26.92	26.74	14.15	14.41	14.13	14.44	14.41	14.14
UMTS Band 4 Rel99	23.61	23.64	23.88	23.78	23.83	9.76	9.82	9.95	9.85	9.82	9.70
UMTS Band 4 HSDPA	22.61	22.93	22.88	22.87	22.69	9.32	9.33	9.26	9.10	9.32	9.44
UMTS Band 4 HSUPA	22.85	22.90	22.75	22.80	22.94	9.39	9.42	9.34	9.21	9.28	9.22
UMTS Band 4 DC-HSDPA	22.62	22.72	22.90	22.93	22.86	9.33	9.11	9.43	9.29	9.32	9.40
UMTS Band 2 Rel99	23.64	23.68	23.91	23.83	23.83	11.41	11.16	11.37	11.36	11.27	11.22
UMTS Band 2 HSDPA	22.63	22.76	22.79	22.77	22.85	11.18	11.12	11.26	11.41	11.16	11.30
UMTS Band 2 HSUPA	22.64	22.68	22.94	22.79	22.62	11.18	11.28	11.35	11.30	11.34	11.44
UMTS Band 2 DC-HSDPA	22.95	22.87	22.64	22.82	22.75	11.27	11.20	11.35	11.27	11.10	11.10
CDMA BC1	24.77	24.65	24.60	24.80	24.93	11.43	11.45	11.21	11.28	11.35	11.38
LTE Band 4	23.68	23.89	23.69	23.74	23.74	10.89	10.81	10.86	10.71	10.92	10.80
LTE Band 2	23.60	23.80	23.90	23.68	23.69	11.77	11.81	11.68	11.79	11.95	11.93
LTE Band 25	23.61	23.84	23.63	23.76	23.79	11.82	11.67	11.79	11.90	11.85	11.86

FCC ID: ACJ9TGWW13B	 PCTEST ENGINEERING LABORATORY, INC.	SAR EVALUATION REPORT	 Panasonic	Reviewed by: Quality Manager
Test Dates: 12/15/14 - 01/08/15	DUT Type: Portable Tablet	APPENDIX G: Page 7 of 12		

Moving device away from the phantom:

KDB 616217 §6.2.8 Measured Power [dBm]											
Distance [mm]	20	21	22	23	24	25	26	27	28	29	30
LTE Band 17	16.67	16.73	16.69	16.95	16.86	16.67	23.78	23.65	23.73	23.87	23.94
LTE Band 13	16.78	16.88	16.67	16.77	16.63	16.86	23.68	23.74	23.60	23.87	23.84
Distance [mm]	30	31	32	33	34	35	36	37	38	39	40
GSM 850 GMSK 1TX	26.45	26.20	26.26	26.31	26.20	26.35	33.16	33.18	33.24	33.27	33.43
GSM 850 GMSK 2TX	24.71	24.61	24.76	24.70	24.89	24.61	33.30	33.29	33.33	33.32	33.34
GSM 850 8PSK 1TX	25.16	25.18	25.40	25.43	25.11	25.12	27.84	27.71	27.69	27.65	27.68
GSM 850 8PSK 2TX	24.32	24.38	24.45	24.41	24.23	24.15	27.66	27.83	27.69	27.95	27.67
GSM 850 8PSK 3TX	22.23	22.10	22.22	22.36	22.29	22.25	27.76	27.84	27.74	27.80	27.87
GSM 850 8PSK 4TX	21.43	21.19	21.22	21.26	21.44	21.32	27.94	27.95	27.93	27.91	27.67
UMTS Band 5 Re199	17.44	17.21	17.32	17.11	17.34	17.12	23.64	23.73	23.71	23.82	23.86
UMTS Band 5 HSDPA	16.84	16.91	16.60	16.91	16.84	16.69	22.63	22.92	22.60	22.62	22.69
UMTS Band 5 HSUPA	16.91	16.83	16.82	16.75	16.85	16.63	22.95	22.60	22.78	22.67	22.74
UMTS Band 5 DC-HSDPA	16.90	16.92	16.91	16.65	16.67	16.65	22.62	22.75	22.94	22.61	22.68
CDMA BC10	17.76	17.62	17.94	17.80	17.71	17.80	24.74	24.65	24.85	24.60	24.90
CDMA BC0	17.88	17.61	17.94	17.69	17.88	17.66	24.82	24.93	24.75	24.81	24.73
LTE Band 5	16.90	16.84	16.77	16.92	16.71	16.79	23.93	23.66	23.77	23.93	23.82
Distance [mm]	8	9	10	11	12	13	14	15	16	17	18
GSM 1900 GMSK 1TX	20.19	20.45	20.19	20.38	20.44	20.41	30.12	30.12	30.39	30.38	30.20
GSM 1900 GMSK 2TX	17.69	17.80	17.65	17.95	17.72	17.74	30.17	30.21	30.45	30.25	30.37
GSM 1900 8PSK 1TX	20.75	20.64	20.63	20.67	20.78	20.94	26.84	26.69	26.79	26.78	26.61
GSM 1900 8PSK 2TX	17.40	17.16	17.42	17.13	17.18	17.19	26.71	26.94	26.92	26.64	26.68
GSM 1900 8PSK 3TX	15.41	15.16	15.14	15.13	15.36	15.26	26.66	26.87	26.70	26.71	26.72
GSM 1900 8PSK 4TX	14.26	14.10	14.21	14.37	14.45	14.24	26.75	26.88	26.78	26.83	26.69
UMTS Band 4 Re199	9.82	9.60	9.75	9.73	9.93	9.87	23.74	23.80	23.95	23.92	23.65
UMTS Band 4 HSDPA	9.45	9.39	9.12	9.35	9.43	9.34	22.60	22.66	22.81	22.74	22.77
UMTS Band 4 HSUPA	9.27	9.26	9.21	9.37	9.31	9.13	22.82	22.77	22.84	22.91	22.68
UMTS Band 4 DC-HSDPA	9.11	9.31	9.32	9.28	9.28	9.37	22.73	22.78	22.63	22.73	22.81
UMTS Band 2 Re199	11.37	11.45	11.21	11.22	11.43	11.38	23.64	23.90	23.67	23.73	23.92
UMTS Band 2 HSDPA	11.42	11.42	11.41	11.37	11.15	11.36	22.64	22.69	22.80	22.63	22.62
UMTS Band 2 HSUPA	11.10	11.12	11.43	11.30	11.16	11.38	22.74	22.87	22.63	22.79	22.93
UMTS Band 2 DC-HSDPA	11.38	11.44	11.27	11.41	11.33	11.22	22.65	22.80	22.62	22.92	22.61
CDMA BC1	11.32	11.39	11.40	11.10	11.35	11.21	24.89	24.67	24.83	24.79	24.95
LTE Band 4	10.84	10.67	10.79	10.90	10.95	10.73	23.90	23.61	23.81	23.73	23.87
LTE Band 2	11.74	11.71	11.67	11.64	11.79	11.79	23.93	23.89	23.77	23.94	23.90
LTE Band 25	11.85	11.71	11.81	11.65	11.71	11.75	23.93	23.61	23.65	23.82	23.89



Based on the most conservative measured triggering distance of 4 mm for all modes, additional SAR measurements were required at 3 mm from the right edge - tilt.

FCC ID: ACJ9TGWW13B	 PCTEST ENGINEERING LABORATORY, INC.	SAR EVALUATION REPORT	 Panasonic	Reviewed by: Quality Manager
Test Dates: 12/15/14 - 01/08/15	DUT Type: Portable Tablet	APPENDIX G: Page 8 of 12		

Top Edge

Moving device toward the phantom:



KDB 616217 §6.2.6 Measured Power [dBm]											
Distance [mm]	22	21	20	19	18	17	16	15	14	13	12
LTE Band 17	23.84	23.89	23.63	23.83	23.94	16.88	16.83	16.75	16.82	16.66	16.90
LTE Band 13	23.62	23.64	23.80	23.71	23.63	16.93	16.74	16.73	16.63	16.80	16.82
Distance [mm]	22	21	20	19	18	17	16	15	14	13	12
GSM 850 GMSK ITX	33.21	33.22	33.21	33.38	33.21	26.33	26.36	26.43	26.37	26.26	26.43
GSM 850 GMSK 2TX	33.37	33.15	33.29	33.14	33.18	24.91	24.79	24.77	24.67	24.76	24.78
GSM 850 8PSK ITX	27.65	27.95	27.80	27.65	27.60	25.27	25.38	25.30	25.31	25.44	25.28
GSM 850 8PSK 2TX	27.88	27.74	27.73	27.93	27.93	24.15	24.22	24.22	24.28	24.28	24.17
GSM 850 8PSK 3TX	27.83	27.82	27.77	27.83	27.91	22.31	22.11	22.40	22.42	22.10	22.43
GSM 850 8PSK 4TX	27.60	27.69	27.80	27.82	27.71	21.12	21.13	21.27	21.15	21.13	21.22
UMTS Band 5 Rel99	23.70	23.69	23.75	23.65	23.88	17.45	17.43	17.44	17.31	17.31	17.45
UMTS Band 5 HSDPA	22.87	22.60	22.93	22.92	22.80	16.72	16.69	16.72	16.90	16.78	16.92
UMTS Band 5 HSUPA	22.75	22.61	22.77	22.63	22.62	16.93	16.81	16.63	16.79	16.80	16.62
UMTS Band 5 DC-HSDPA	22.83	22.70	22.95	22.84	22.87	16.64	16.66	16.61	16.73	16.61	16.65
CDMA BC10	24.66	24.72	24.91	24.76	24.93	17.75	17.87	17.90	17.84	17.84	17.73
CDMA BC0	24.73	24.81	24.71	24.80	24.63	17.76	17.85	17.93	17.92	17.85	17.74
LTE Band 5	23.90	23.91	23.87	23.88	23.63	16.81	16.84	16.84	16.70	16.70	16.69
Distance [mm]	28	27	26	25	24	23	22	21	20	19	18
GSM 1900 GMSK ITX	30.13	30.10	30.11	30.42	30.44	20.27	20.43	20.34	20.13	20.43	20.43
GSM 1900 GMSK 2TX	30.32	30.25	30.25	30.11	30.34	17.94	17.78	17.76	17.67	17.89	17.76
GSM 1900 8PSK ITX	26.73	26.93	26.83	26.90	26.63	20.65	20.81	20.83	20.80	20.82	20.88
GSM 1900 8PSK 2TX	26.74	26.89	26.62	26.75	26.83	17.12	17.25	17.34	17.10	17.34	17.37
GSM 1900 8PSK 3TX	26.84	26.72	26.68	26.94	26.83	15.43	15.12	15.44	15.19	15.41	15.32
GSM 1900 8PSK 4TX	26.62	26.84	26.74	26.66	26.75	14.37	14.30	14.42	14.43	14.20	14.36
UMTS Band 4 Rel99	23.86	23.76	23.74	23.89	23.65	9.70	9.89	9.66	9.93	9.88	9.88
UMTS Band 4 HSDPA	22.80	22.62	22.61	22.85	22.88	9.14	9.37	9.43	9.30	9.24	9.18
UMTS Band 4 HSUPA	22.66	22.76	22.65	22.61	22.89	9.18	9.18	9.26	9.41	9.41	9.37
UMTS Band 4 DC-HSDPA	22.65	22.94	22.86	22.69	22.93	9.35	9.15	9.37	9.38	9.45	9.37
UMTS Band 2 Rel99	23.78	23.77	23.81	23.70	23.60	11.40	11.25	11.35	11.28	11.43	11.10
UMTS Band 2 HSDPA	22.71	22.64	22.73	22.74	22.93	11.22	11.16	11.45	11.20	11.11	11.22
UMTS Band 2 HSUPA	22.67	22.64	22.80	22.61	22.62	11.40	11.32	11.40	11.36	11.45	11.44
UMTS Band 2 DC-HSDPA	22.73	22.89	22.89	22.64	22.60	11.20	11.21	11.27	11.33	11.41	11.41
CDMA BC1	24.69	24.65	24.86	24.60	24.74	11.23	11.28	11.18	11.39	11.45	11.29
LTE Band 4	23.87	23.65	23.94	23.84	23.69	10.85	10.61	10.76	10.61	10.72	10.77
LTE Band 2	23.77	23.95	23.87	23.74	23.68	11.86	11.75	11.92	11.95	11.81	11.79
LTE Band 25	23.80	23.64	23.89	23.87	23.93	11.74	11.90	11.76	11.64	11.93	11.72

FCC ID: ACJ9TGWW13B	 PCTEST ENGINEERING LABORATORY, INC.	SAR EVALUATION REPORT		Reviewed by: Quality Manager
Test Dates: 12/15/14 - 01/08/15	DUT Type: Portable Tablet	APPENDIX G: Page 9 of 12		

Moving device away from the phantom:

KDB 616217 §6.2.8 Measured Power [dBm]											
Distance [mm]	35	36	37	38	39	40	41	42	43	44	45
LTE Band 17	16.76	16.64	16.86	16.94	16.67	16.87	23.92	23.94	23.77	23.83	23.91
LTE Band 13	16.64	16.73	16.93	16.75	16.73	16.88	23.64	23.75	23.64	23.71	23.61
Distance [mm]	32	33	34	35	36	37	38	39	40	41	42
GSM 850 GMSK ITX	26.38	26.39	26.25	26.20	26.23	26.12	33.18	33.42	33.32	33.37	33.22
GSM 850 GMSK 2TX	24.67	24.76	24.71	24.86	24.60	24.95	33.25	33.32	33.24	33.27	33.11
GSM 850 8PSK ITX	25.31	25.14	25.13	25.28	25.45	25.20	27.72	27.89	27.89	27.89	27.73
GSM 850 8PSK 2TX	24.40	24.28	24.35	24.43	24.11	24.45	27.67	27.71	27.86	27.61	27.67
GSM 850 8PSK 3TX	22.11	22.45	22.43	22.11	22.12	22.11	27.78	27.95	27.68	27.84	27.89
GSM 850 8PSK 4TX	21.35	21.24	21.15	21.37	21.14	21.38	27.75	27.95	27.78	27.94	27.90
UMTS Band 5 Re199	17.28	17.41	17.18	17.29	17.14	17.29	23.74	23.76	23.67	23.68	23.66
UMTS Band 5 HSDPA	16.63	16.68	16.74	16.78	16.65	16.82	22.62	22.80	22.74	22.66	22.79
UMTS Band 5 HSUPA	16.69	16.88	16.76	16.88	16.77	16.82	22.76	22.78	22.66	22.62	22.68
UMTS Band 5 DC-HSDPA	16.79	16.66	16.65	16.81	16.81	16.66	22.67	22.71	22.63	22.69	22.63
CDMA BC10	17.71	17.74	17.86	17.84	17.83	17.89	24.68	24.86	24.84	24.63	24.66
CDMA BC0	17.77	17.62	17.83	17.64	17.89	17.78	24.70	24.85	24.88	24.82	24.80
LTE Band 5	16.88	16.72	16.89	16.62	16.81	16.80	23.91	23.88	23.92	23.75	23.87
Distance [mm]	21	22	23	24	25	26	27	28	29	30	31
GSM 1900 GMSK ITX	20.33	20.45	20.31	20.40	20.35	20.30	30.44	30.30	30.19	30.18	30.36
GSM 1900 GMSK 2TX	17.95	17.95	17.75	17.67	17.89	17.92	30.12	30.23	30.35	30.29	30.22
GSM 1900 8PSK ITX	20.68	20.70	20.78	20.91	20.65	20.72	26.66	26.64	26.70	26.67	26.65
GSM 1900 8PSK 2TX	17.24	17.44	17.32	17.38	17.39	17.16	26.60	26.92	26.60	26.84	26.93
GSM 1900 8PSK 3TX	15.37	15.30	15.22	15.17	15.38	15.29	26.72	26.80	26.77	26.86	26.71
GSM 1900 8PSK 4TX	14.32	14.20	14.20	14.39	14.25	14.20	26.82	26.78	26.80	26.95	26.84
UMTS Band 4 Re199	9.77	9.71	9.86	9.95	9.60	9.64	23.84	23.95	23.73	23.63	23.88
UMTS Band 4 HSDPA	9.10	9.41	9.11	9.29	9.27	9.37	22.64	22.60	22.91	22.88	22.92
UMTS Band 4 HSUPA	9.29	9.45	9.16	9.40	9.25	9.14	22.90	22.71	22.75	22.66	22.63
UMTS Band 4 DC-HSDPA	9.32	9.41	9.38	9.36	9.45	9.14	22.81	22.92	22.85	22.79	22.94
UMTS Band 2 Re199	11.10	11.28	11.15	11.38	11.21	11.18	23.93	23.63	23.88	23.65	23.87
UMTS Band 2 HSDPA	11.24	11.33	11.30	11.16	11.11	11.13	22.95	22.61	22.79	22.63	22.83
UMTS Band 2 HSUPA	11.38	11.28	11.37	11.25	11.43	11.38	22.75	22.72	22.95	22.66	22.89
UMTS Band 2 DC-HSDPA	11.25	11.19	11.13	11.43	11.39	11.31	22.91	22.67	22.86	22.80	22.67
CDMA BC1	11.29	11.16	11.19	11.26	11.30	11.22	24.91	24.71	24.81	24.62	24.77
LTE Band 4	10.67	10.78	10.73	10.92	10.73	10.91	23.83	23.89	23.92	23.81	23.94
LTE Band 2	11.82	11.89	11.85	11.81	11.90	11.81	23.92	23.68	23.87	23.94	23.68
LTE Band 25	11.61	11.74	11.83	11.87	11.71	11.82	23.88	23.73	23.81	23.70	23.85



Based on the most conservative measured triggering distance of 17 mm for all modes, additional SAR measurements were required at 16 mm from the top edge.

FCC ID: ACJ9TGWW13B	 PCTEST ENGINEERING LABORATORY, INC.	SAR EVALUATION REPORT		Reviewed by: Quality Manager
Test Dates: 12/15/14 - 01/08/15	DUT Type: Portable Tablet	APPENDIX G: Page 10 of 12		

Top Edge - Tilt

Moving device toward the phantom:



KDB 616217 §6.2.6 Measured Power [dBm]											
Distance [mm]	22	21	20	19	18	17	16	15	14	13	12
LTE Band 17	23.89	23.69	23.82	23.79	23.71	16.89	16.86	16.70	16.65	16.85	16.74
LTE Band 13	23.91	23.85	23.67	23.75	23.85	16.94	16.90	16.89	16.78	16.69	16.65
Distance [mm]	22	21	20	19	18	17	16	15	14	13	12
GSM 850 GMSK ITX	33.18	33.18	33.37	33.19	33.38	26.26	26.13	26.41	26.30	26.20	26.31
GSM 850 GMSK 2TX	33.40	33.33	33.39	33.40	33.12	24.70	24.74	24.65	24.61	24.60	24.74
GSM 850 8PSK ITX	27.67	27.70	27.76	27.67	27.77	25.27	25.40	25.19	25.30	25.19	25.14
GSM 850 8PSK 2TX	27.61	27.93	27.67	27.75	27.80	24.27	24.32	24.45	24.27	24.21	24.41
GSM 850 8PSK 3TX	27.83	27.91	27.63	27.87	27.94	22.27	22.11	22.12	22.23	22.16	22.19
GSM 850 8PSK 4TX	27.88	27.70	27.82	27.75	27.63	21.39	21.32	21.13	21.31	21.13	21.22
UMTS Band 5 Rel99	23.60	23.88	23.85	23.91	23.90	17.23	17.23	17.11	17.34	17.18	17.33
UMTS Band 5 HSDPA	22.63	22.74	22.70	22.80	22.66	16.65	16.63	16.73	16.90	16.60	16.68
UMTS Band 5 HSUPA	22.74	22.60	22.78	22.66	22.88	16.93	16.77	16.64	16.95	16.86	16.70
UMTS Band 5 DC-HSDPA	22.90	22.76	22.83	22.72	22.61	16.82	16.94	16.76	16.84	16.80	16.93
CDMA BC10	24.67	24.89	24.68	24.92	24.68	17.63	17.78	17.89	17.80	17.63	17.68
CDMA BC0	24.89	24.87	24.90	24.85	24.82	17.93	17.82	17.81	17.64	17.93	17.61
LTE Band 5	23.66	23.83	23.85	23.69	23.82	16.78	16.86	16.61	16.60	16.95	16.92
Distance [mm]	28	27	26	25	24	23	22	21	20	19	18
GSM 1900 GMSK ITX	30.27	30.35	30.12	30.39	30.26	20.15	20.44	20.35	20.44	20.10	20.37
GSM 1900 GMSK 2TX	30.42	30.13	30.23	30.20	30.35	17.91	17.68	17.94	17.66	17.91	17.79
GSM 1900 8PSK ITX	26.73	26.88	26.71	26.61	26.95	20.63	20.68	20.72	20.79	20.94	20.60
GSM 1900 8PSK 2TX	26.62	26.62	26.67	26.81	26.73	17.44	17.34	17.43	17.16	17.39	17.16
GSM 1900 8PSK 3TX	26.95	26.79	26.60	26.78	26.70	15.18	15.38	15.12	15.33	15.18	15.38
GSM 1900 8PSK 4TX	26.84	26.94	26.63	26.75	26.78	14.44	14.31	14.36	14.32	14.36	14.17
UMTS Band 4 Rel99	23.88	23.90	23.77	23.72	23.66	9.77	9.65	9.93	9.81	9.94	9.87
UMTS Band 4 HSDPA	22.71	22.92	22.84	22.70	22.73	9.38	9.36	9.19	9.33	9.12	9.17
UMTS Band 4 HSUPA	22.87	22.69	22.70	22.95	22.74	9.45	9.33	9.32	9.36	9.39	9.12
UMTS Band 4 DC-HSDPA	22.79	22.70	22.61	22.86	22.72	9.45	9.34	9.21	9.33	9.15	9.22
UMTS Band 2 Rel99	23.95	23.76	23.65	23.81	23.73	11.19	11.44	11.14	11.16	11.19	11.38
UMTS Band 2 HSDPA	22.91	22.89	22.89	22.77	22.74	11.26	11.34	11.19	11.20	11.15	11.38
UMTS Band 2 HSUPA	22.86	22.90	22.68	22.94	22.75	11.15	11.17	11.16	11.40	11.36	11.19
UMTS Band 2 DC-HSDPA	22.90	22.76	22.73	22.85	22.72	11.32	11.18	11.11	11.35	11.20	11.15
CDMA BC1	24.71	24.72	24.62	24.88	24.62	11.21	11.37	11.19	11.36	11.39	11.31
LTE Band 4	23.69	23.84	23.83	23.91	23.61	10.71	10.87	10.82	10.90	10.80	10.66
LTE Band 2	23.95	23.76	23.79	23.93	23.78	11.67	11.93	11.89	11.69	11.82	11.83
LTE Band 25	23.62	23.83	23.72	23.92	23.82	11.88	11.73	11.92	11.65	11.83	11.73

FCC ID: ACJ9TGWW13B	 PCTEST ENGINEERING LABORATORY, INC.	SAR EVALUATION REPORT		Reviewed by: Quality Manager
Test Dates: 12/15/14 - 01/08/15	DUT Type: Portable Tablet	APPENDIX G: Page 11 of 12		

Moving device away from the phantom:

KDB 616217 §6.2.8 Measured Power [dBm]											
Distance [mm]	35	36	37	38	39	40	41	42	43	44	45
LTE Band 17	16.85	16.67	16.83	16.68	16.95	16.84	23.66	23.70	23.91	23.86	23.67
LTE Band 13	16.67	16.64	16.79	16.87	16.62	16.61	23.77	23.63	23.63	23.62	23.81
Distance [mm]	32	33	34	35	36	37	38	39	40	41	42
GSM 850 GMSK ITX	26.43	26.28	26.32	26.34	26.27	26.28	33.28	33.13	33.43	33.45	33.12
GSM 850 GMSK 2TX	24.82	24.67	24.91	24.79	24.88	24.89	33.21	33.13	33.36	33.22	33.44
GSM 850 8PSK ITX	25.42	25.35	25.40	25.17	25.21	25.12	27.61	27.76	27.77	27.87	27.81
GSM 850 8PSK 2TX	24.11	24.18	24.21	24.11	24.26	24.13	27.95	27.89	27.95	27.91	27.72
GSM 850 8PSK 3TX	22.45	22.22	22.42	22.25	22.28	22.26	27.80	27.65	27.80	27.91	27.75
GSM 850 8PSK 4TX	21.44	21.17	21.13	21.30	21.40	21.38	27.71	27.72	27.84	27.85	27.83
UMTS Band 5 Re199	17.28	17.29	17.16	17.36	17.34	17.16	23.79	23.68	23.95	23.83	23.78
UMTS Band 5 HSDPA	16.60	16.78	16.82	16.88	16.71	16.73	22.94	22.85	22.89	22.75	22.87
UMTS Band 5 HSUPA	16.60	16.81	16.90	16.91	16.83	16.91	22.80	22.71	22.64	22.88	22.85
UMTS Band 5 DC-HSDPA	16.77	16.78	16.65	16.92	16.90	16.86	22.89	22.85	22.69	22.65	22.75
CDMA BC10	17.61	17.88	17.88	17.74	17.61	17.92	24.72	24.62	24.68	24.74	24.89
CDMA BC0	17.93	17.63	17.61	17.61	17.79	17.61	24.67	24.91	24.83	24.61	24.67
LTE Band 5	16.92	16.79	16.94	16.87	16.86	16.95	23.86	23.71	23.82	23.95	23.80
Distance [mm]	21	22	23	24	25	26	27	28	29	30	31
GSM 1900 GMSK ITX	20.24	20.17	20.31	20.25	20.13	20.15	30.30	30.29	30.41	30.22	30.26
GSM 1900 GMSK 2TX	17.61	17.90	17.83	17.79	17.62	17.94	30.36	30.12	30.28	30.22	30.15
GSM 1900 8PSK ITX	20.72	20.86	20.76	20.83	20.72	20.75	26.63	26.66	26.87	26.93	26.71
GSM 1900 8PSK 2TX	17.30	17.16	17.45	17.17	17.44	17.36	26.92	26.82	26.64	26.63	26.73
GSM 1900 8PSK 3TX	15.38	15.35	15.25	15.43	15.32	15.43	26.68	26.74	26.60	26.71	26.68
GSM 1900 8PSK 4TX	14.33	14.14	14.30	14.12	14.39	14.43	26.88	26.82	26.87	26.71	26.65
UMTS Band 4 Re199	9.74	9.65	9.89	9.62	9.86	9.75	23.80	23.71	23.93	23.87	23.89
UMTS Band 4 HSDPA	9.16	9.14	9.41	9.37	9.34	9.19	22.68	22.87	22.83	22.69	22.82
UMTS Band 4 HSUPA	9.13	9.33	9.45	9.16	9.37	9.14	22.86	22.72	22.75	22.63	22.73
UMTS Band 4 DC-HSDPA	9.22	9.41	9.18	9.20	9.34	9.35	22.90	22.64	22.68	22.73	22.80
UMTS Band 2 Re199	11.42	11.16	11.24	11.21	11.12	11.11	23.62	23.78	23.67	23.65	23.66
UMTS Band 2 HSDPA	11.20	11.11	11.40	11.11	11.12	11.34	22.62	22.67	22.93	22.83	22.75
UMTS Band 2 HSUPA	11.13	11.14	11.27	11.28	11.21	11.33	22.94	22.90	22.86	22.94	22.74
UMTS Band 2 DC-HSDPA	11.14	11.29	11.18	11.30	11.40	11.40	22.73	22.90	22.94	22.63	22.77
CDMA BC1	11.15	11.38	11.34	11.41	11.27	11.10	24.84	24.79	24.74	24.60	24.63
LTE Band 4	10.74	10.95	10.82	10.61	10.90	10.62	23.73	23.67	23.74	23.60	23.70
LTE Band 2	11.89	11.90	11.76	11.88	11.68	11.94	23.89	23.78	23.75	23.75	23.95
LTE Band 25	11.65	11.61	11.91	11.65	11.65	11.92	23.69	23.80	23.84	23.79	23.73

Based on the most conservative measured triggering distance of 17 mm for all modes, additional SAR measurements were required at 16 mm from the top edge - tilt.

FCC ID: ACJ9TGWW13B	 PCTEST ENGINEERING LABORATORY, INC.	SAR EVALUATION REPORT	 Panasonic	Reviewed by: Quality Manager
Test Dates: 12/15/14 - 01/08/15	DUT Type: Portable Tablet	APPENDIX G: Page 12 of 12		