

20130129 SystemPerformanceCheck-D750V3 SN 1071

Frequency: 750 MHz; Duty Cycle: 1:1; Room Ambient Temperature: 23.0°C; Liquid Temperature: 22.0°C
Medium parameters used: $f = 750$ MHz; $\sigma = 0.993$ mho/m; $\epsilon_r = 54.933$; $\rho = 1000$ kg/m³

DASY5 Configuration:

- Area Scan Setting: Find Secondary Maximum Within: 2.0 dB and with a peak SAR value greater than 0.0012W/kg
- Averaged Fast SAR: Polynomial fit
- Electronics: DAE4 Sn1259; Calibrated: 2/13/2012
- Probe: EX3DV4 - SN3686; ConvF(8.87, 8.87, 8.87); Calibrated: 2/16/2012;
- Sensor-Surface: 2.5mm (Mechanical Surface Detection)
- Phantom: ELI v5.0 (B); Type: QDOVA001BB; Serial: 1118

Body/Pin=100 mW/Area Scan (61x61x1): Interpolated grid: dx=1.500 mm, dy=1.500 mm

Reference Value = 32.635 V/m; Power Drift = 0.06 dB

Fast SAR: SAR(1 g) = 0.890 W/kg; SAR(10 g) = 0.603 W/kg

Maximum value of SAR (interpolated) = 1.05 W/kg

Body/Pin=100 mW/Zoom Scan (7x7x7)/Cube 0: Measurement grid: dx=5mm, dy=5mm, dz=5mm

Reference Value = 32.635 V/m; Power Drift = 0.06 dB

Peak SAR (extrapolated) = 1.27 W/kg

SAR(1 g) = 0.877 W/kg; SAR(10 g) = 0.583 W/kg

Maximum value of SAR (measured) = 1.06 W/kg

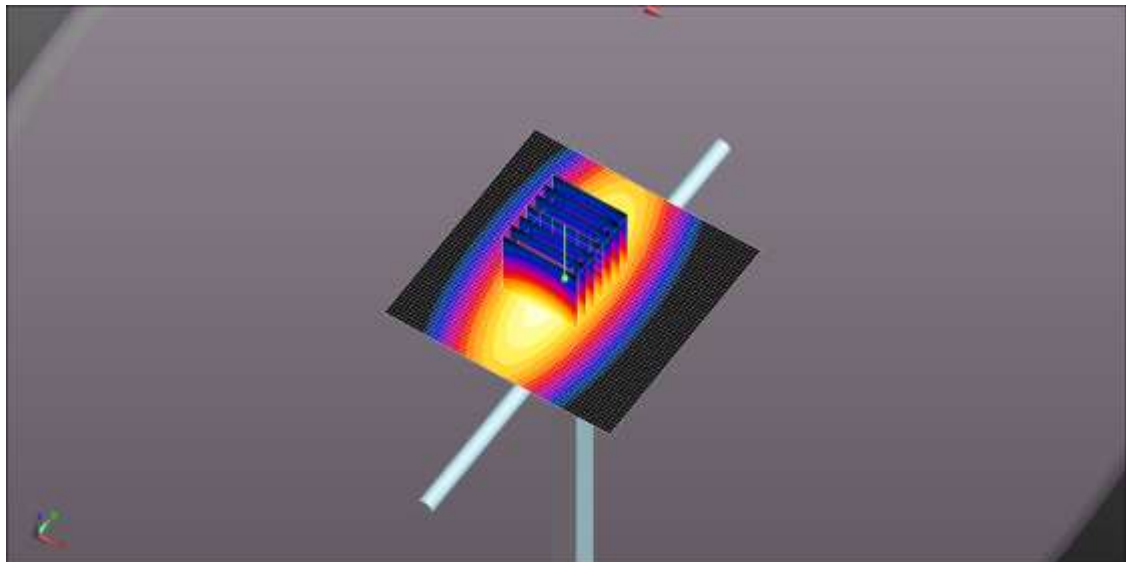
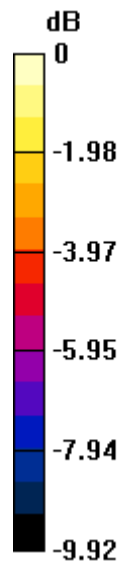

0 dB = 1.06 W/kg = 0.25 dBW/kg

20130129 SystemPerformanceCheck-D750V3 SN 1071

Frequency: 750 MHz; Duty Cycle: 1:1

Body/Pin=100 mW/Z Scan (1x1x21): Measurement grid: dx=20mm, dy=20mm, dz=5mm
Maximum value of SAR (measured) = 1.02 W/kg

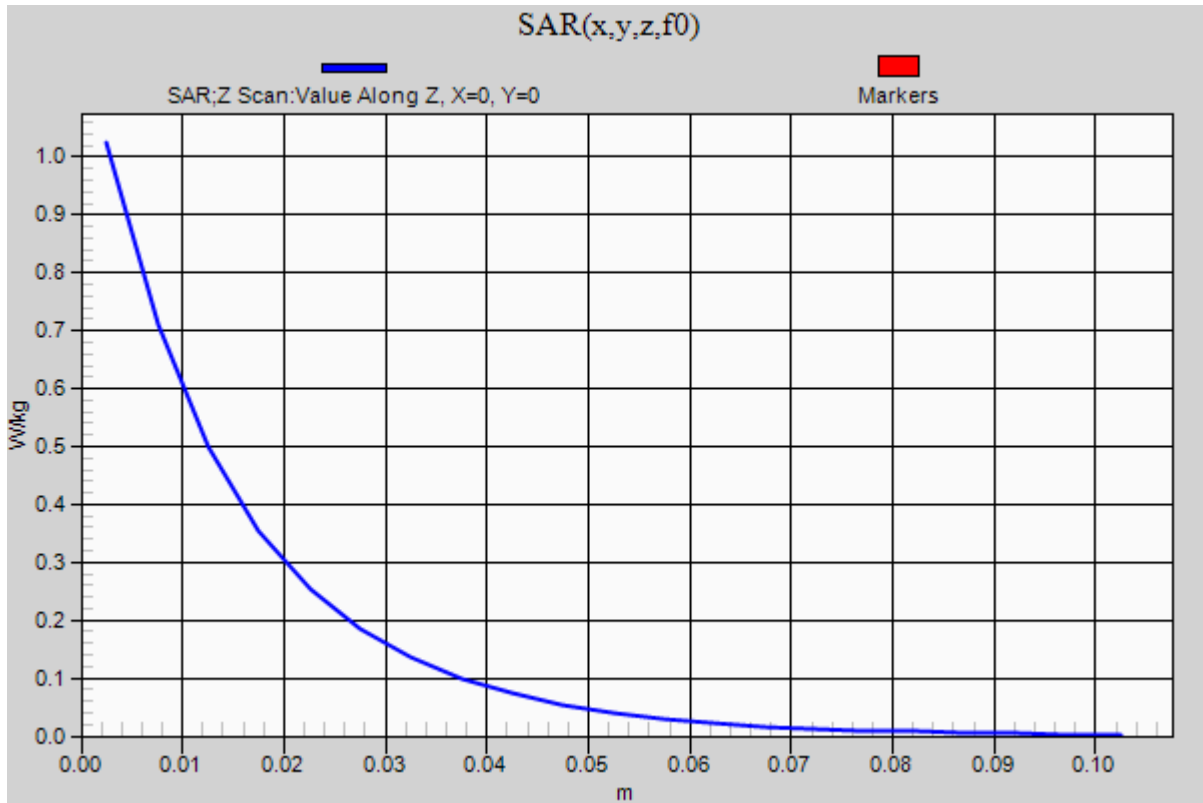

20130130 SystemPerformanceCheck-D750V3 SN 1071

Frequency: 750 MHz; Duty Cycle: 1:1; Room Ambient Temperature: 23.0°C; Liquid Temperature: 22.0°C
Medium parameters used: $f = 750$ MHz; $\sigma = 0.967$ mho/m; $\epsilon_r = 53.651$; $\rho = 1000$ kg/m³

DASY5 Configuration:

- Area Scan Setting: Find Secondary Maximum Within: 2.0 dB and with a peak SAR value greater than 0.0012W/kg
- Averaged Fast SAR: Polynomial fit
- Electronics: DAE4 Sn1259; Calibrated: 2/13/2012
- Probe: EX3DV4 - SN3686; ConvF(8.87, 8.87, 8.87); Calibrated: 2/16/2012;
- Sensor-Surface: 2.5mm (Mechanical Surface Detection)
- Phantom: SAM; Type: QD000P40CD; Serial: 1629

Body/Pin=100 mW/Area Scan (61x61x1): Interpolated grid: dx=1.500 mm, dy=1.500 mm

Reference Value = 32.738 V/m; Power Drift = -0.00 dB

Fast SAR: SAR(1 g) = 0.860 W/kg; SAR(10 g) = 0.583 W/kg

Maximum value of SAR (interpolated) = 1.02 W/kg

Body/Pin=100 mW/Zoom Scan (7x7x7)/Cube 0: Measurement grid: dx=5mm, dy=5mm, dz=5mm

Reference Value = 32.738 V/m; Power Drift = -0.00 dB

Peak SAR (extrapolated) = 1.24 W/kg

SAR(1 g) = 0.852 W/kg; SAR(10 g) = 0.567 W/kg

Maximum value of SAR (measured) = 1.03 W/kg

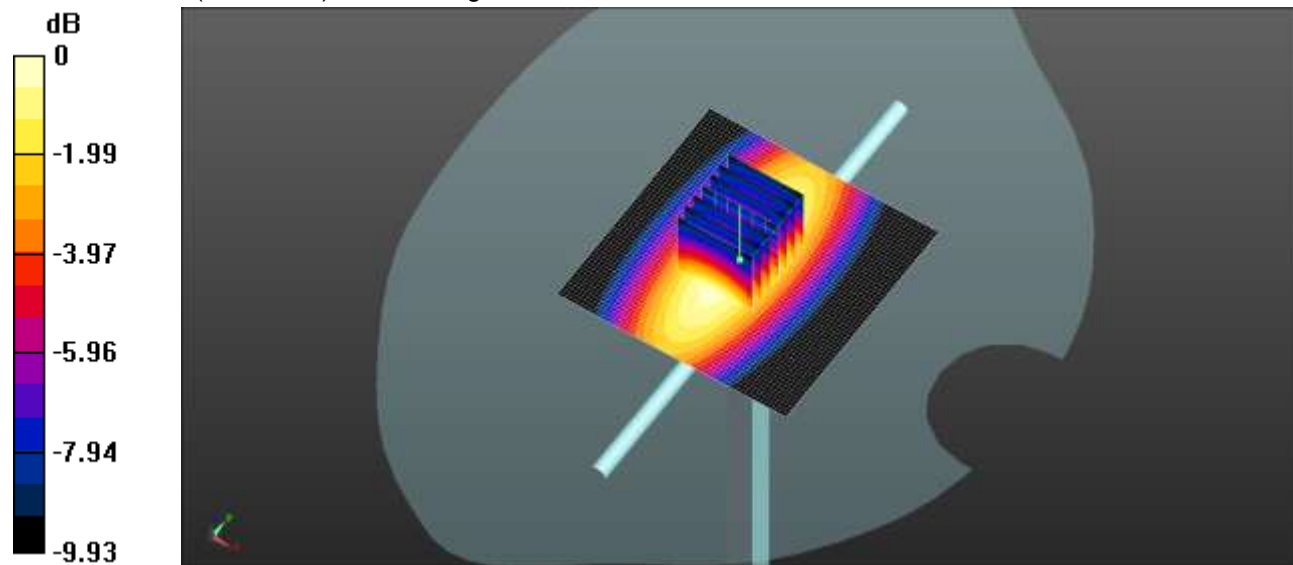

0 dB = 1.03 W/kg = 0.13 dBW/kg

20130130 SystemPerformanceCheck-D750V3 SN 1071

Frequency: 750 MHz; Duty Cycle: 1:1

Body/Pin=100 mW/Z Scan (1x1x21): Measurement grid: dx=20mm, dy=20mm, dz=5mm
Maximum value of SAR (measured) = 0.996 W/kg

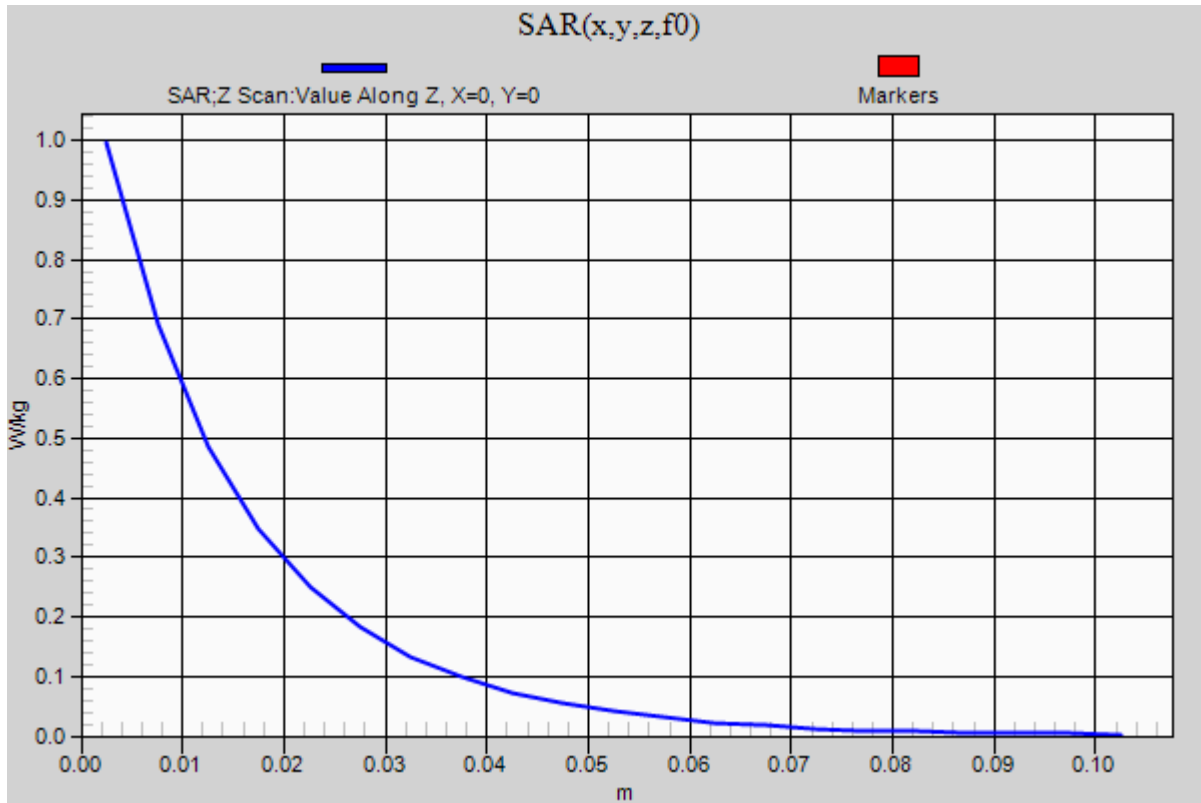

20130204 SystemPerformanceCheck-D835V2 SN 4d117

Frequency: 835 MHz; Duty Cycle: 1:1; Room Ambient Temperature: 24.0°C; Liquid Temperature: 23.0°C
Medium parameters used: $f = 835$ MHz; $\sigma = 0.988$ mho/m; $\epsilon_r = 54.088$; $\rho = 1000$ kg/m³

DASY5 Configuration:

- Area Scan Setting: Find Secondary Maximum Within: 2.0 dB and with a peak SAR value greater than 0.0012W/kg
- Electronics: DAE4 Sn1343; Calibrated: 8/20/2012
- Probe: EX3DV4 - SN3871; ConvF(9.68, 9.68, 9.68); Calibrated: 8/20/2012;
- Sensor-Surface: 2.5mm (Mechanical Surface Detection)
- Phantom: ELI v5.0 A; Type: QDOVA002AA; Serial: 1180

Body/Pin=100 mW/Area Scan (61x61x1): Interpolated grid: dx=1.500 mm, dy=1.500 mm

Reference Value = 34.945 V/m; Power Drift = -0.07 dB

Fast SAR: SAR(1 g) = 0.987 W/kg; SAR(10 g) = 0.661 W/kg

Maximum value of SAR (interpolated) = 1.17 W/kg

Body/Pin=100 mW/Zoom Scan (7x7x7)/Cube 0: Measurement grid: dx=5mm, dy=5mm, dz=5mm

Reference Value = 34.945 V/m; Power Drift = -0.07 dB

Peak SAR (extrapolated) = 1.41 W/kg

SAR(1 g) = 0.958 W/kg; SAR(10 g) = 0.633 W/kg

Maximum value of SAR (measured) = 1.16 W/kg

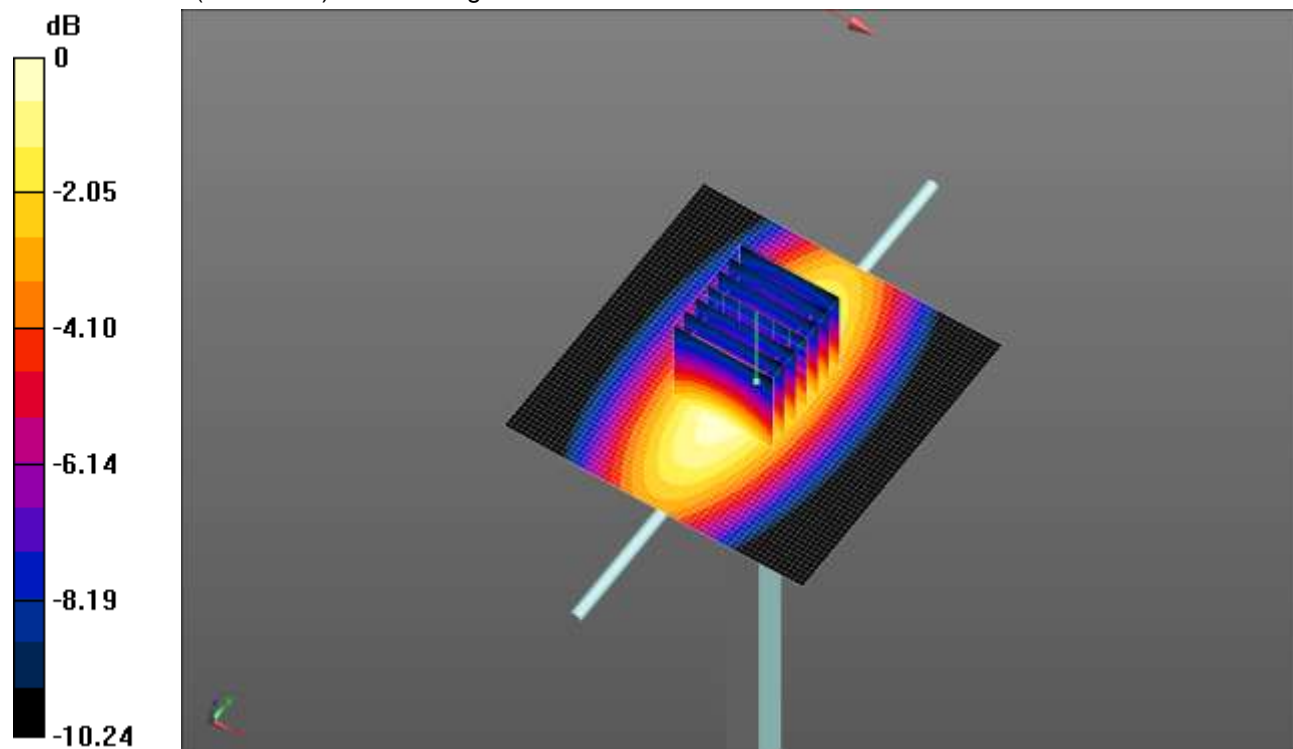

0 dB = 1.16 W/kg = 0.64 dBW/kg

20130204 SystemPerformanceCheck-D835V2 SN 4d117

Frequency: 835 MHz; Duty Cycle: 1:1

Body/Pin=100 mW/Z Scan (1x1x21): Measurement grid: dx=20mm, dy=20mm, dz=5mm
Maximum value of SAR (measured) = 1.16 W/kg

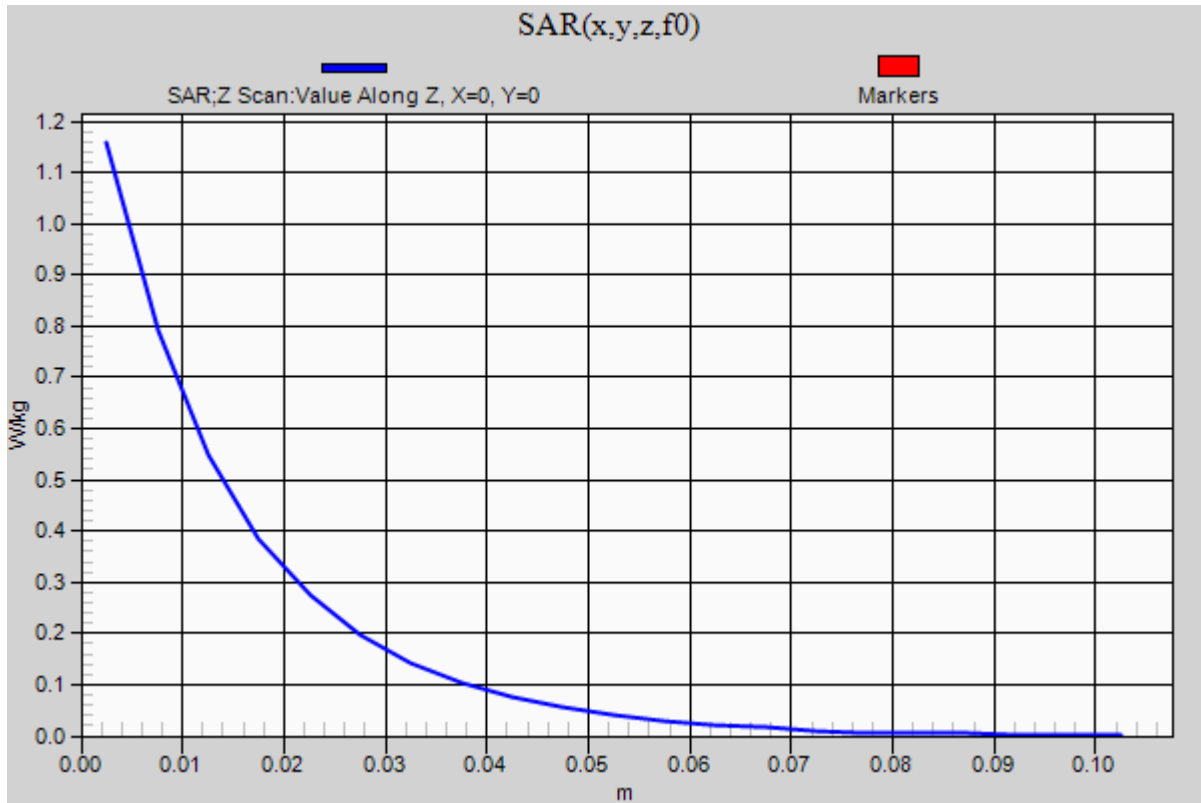

20130204 SystemPerformanceCheck-D1900V2 SN 5d140

Frequency: 1900 MHz; Duty Cycle: 1:1; Room Ambient Temperature: 23.0°C; Liquid Temperature: 22.0°C
Medium parameters used: $f = 1900$ MHz; $\sigma = 1.571$ mho/m; $\epsilon_r = 51.469$; $\rho = 1000$ kg/m³

DASY5 Configuration:

- Area Scan Setting: Find Secondary Maximum Within: 2.0 dB and with a peak SAR value greater than 0.0012W/kg
- Averaged Fast SAR: Polynomial fit
- Electronics: DAE3 Sn427; Calibrated: 1/9/2013
- Probe: EX3DV4 - SN3686; ConvF(7.04, 7.04, 7.04); Calibrated: 2/16/2012;
- Sensor-Surface: 2.5mm (Mechanical Surface Detection)
- Phantom: ELI v5.0 (B); Type: QDOVA001BB; Serial: 1118

Body/Pin=100 mW/Area Scan (61x61x1): Interpolated grid: dx=1.500 mm, dy=1.500 mm

Reference Value = 55.867 V/m; Power Drift = 0.16 dB

Fast SAR: SAR(1 g) = 4.12 W/kg; SAR(10 g) = 2.13 W/kg

Maximum value of SAR (interpolated) = 5.51 W/kg

Body/Pin=100 mW/Zoom Scan (7x7x7)/Cube 0: Measurement grid: dx=5mm, dy=5mm, dz=5mm

Reference Value = 55.867 V/m; Power Drift = 0.16 dB

Peak SAR (extrapolated) = 7.16 W/kg

SAR(1 g) = 3.96 W/kg; SAR(10 g) = 2.08 W/kg

Maximum value of SAR (measured) = 5.35 W/kg

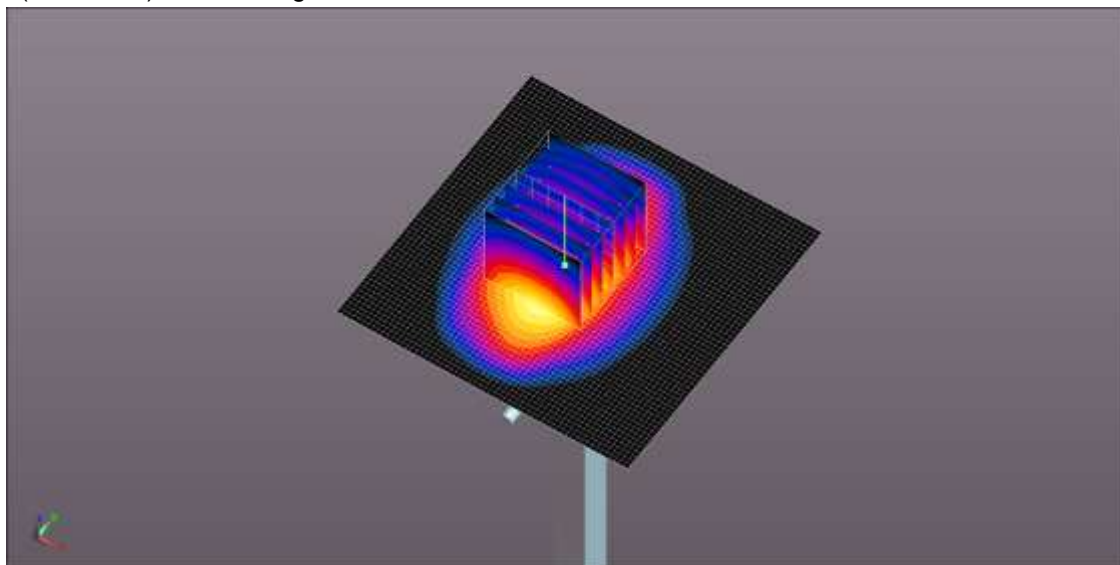
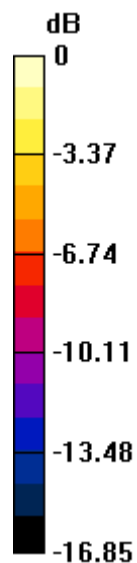

0 dB = 5.35 W/kg = 7.28 dBW/kg

20130204 SystemPerformanceCheck-D1900V2 SN 5d140

Frequency: 1900 MHz; Duty Cycle: 1:1

Body/Pin=100 mW/Z Scan (1x1x21): Measurement grid: dx=20mm, dy=20mm, dz=5mm
Maximum value of SAR (measured) = 4.76 W/kg

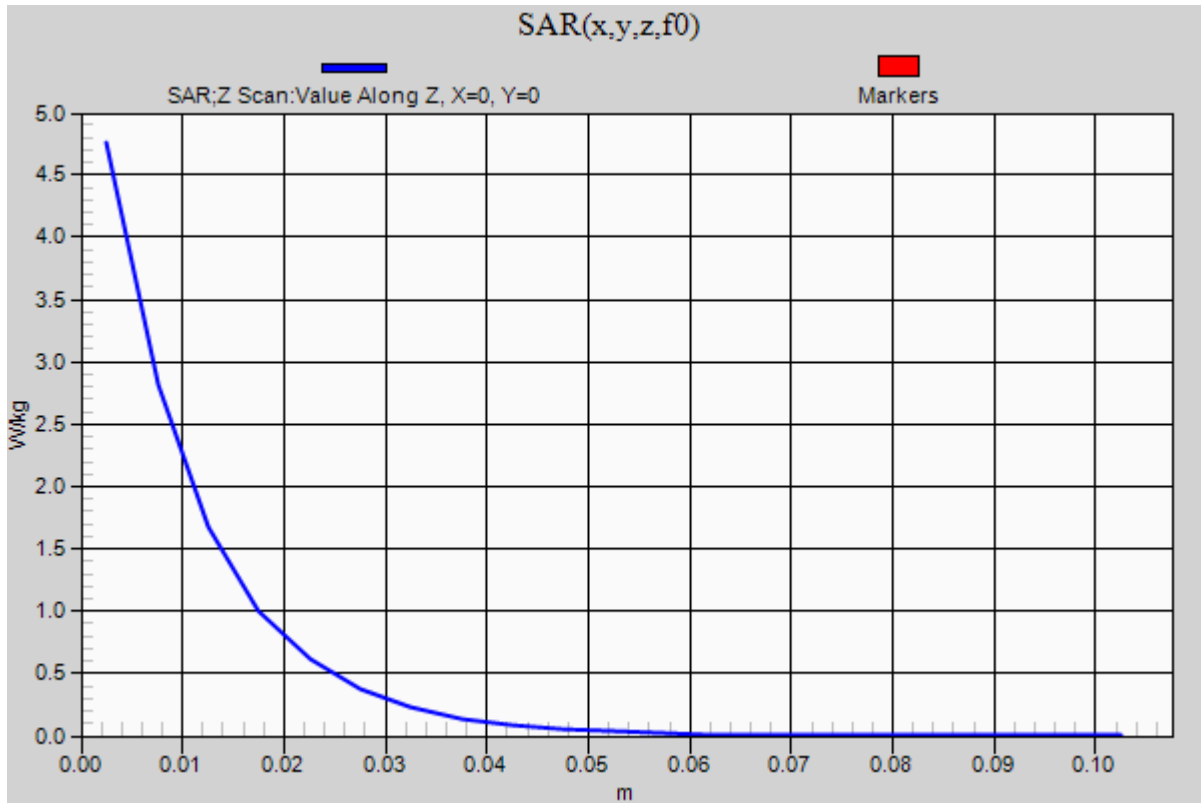

20130205 SystemPerformanceCheck-D835V2 SN 4d117

Frequency: 835 MHz; Duty Cycle: 1:1; Room Ambient Temperature: 24.0°C; Liquid Temperature: 23.0°C
Medium parameters used: $f = 835$ MHz; $\sigma = 0.996$ mho/m; $\epsilon_r = 54.798$; $\rho = 1000$ kg/m³

DASY5 Configuration:

- Area Scan Setting: Find Secondary Maximum Within: 2.0 dB and with a peak SAR value greater than 0.0012W/kg
- Electronics: DAE4 Sn1343; Calibrated: 8/20/2012
- Probe: EX3DV4 - SN3871; ConvF(9.68, 9.68, 9.68); Calibrated: 8/20/2012;
- Sensor-Surface: 2.5mm (Mechanical Surface Detection (Locations From Previous Scan Used)), Sensor-Surface: 2.5mm (Mechanical Surface Detection)
- Phantom: SAM with CRP; Type: SAM; Serial: GF-VE20

Body/Pin=100 mW/Area Scan (61x61x1): Interpolated grid: dx=1.500 mm, dy=1.500 mm

Reference Value = 35.861 V/m; Power Drift = -0.01 dB

Fast SAR: SAR(1 g) = 0.950 W/kg; SAR(10 g) = 0.639 W/kg

Maximum value of SAR (interpolated) = 1.12 W/kg

Body/Pin=100 mW/Zoom Scan (7x7x7)/Cube 0: Measurement grid: dx=5mm, dy=5mm, dz=5mm

Reference Value = 35.861 V/m; Power Drift = -0.01 dB

Peak SAR (extrapolated) = 1.53 W/kg

SAR(1 g) = 1.03 W/kg; SAR(10 g) = 0.678 W/kg

Maximum value of SAR (measured) = 1.25 W/kg

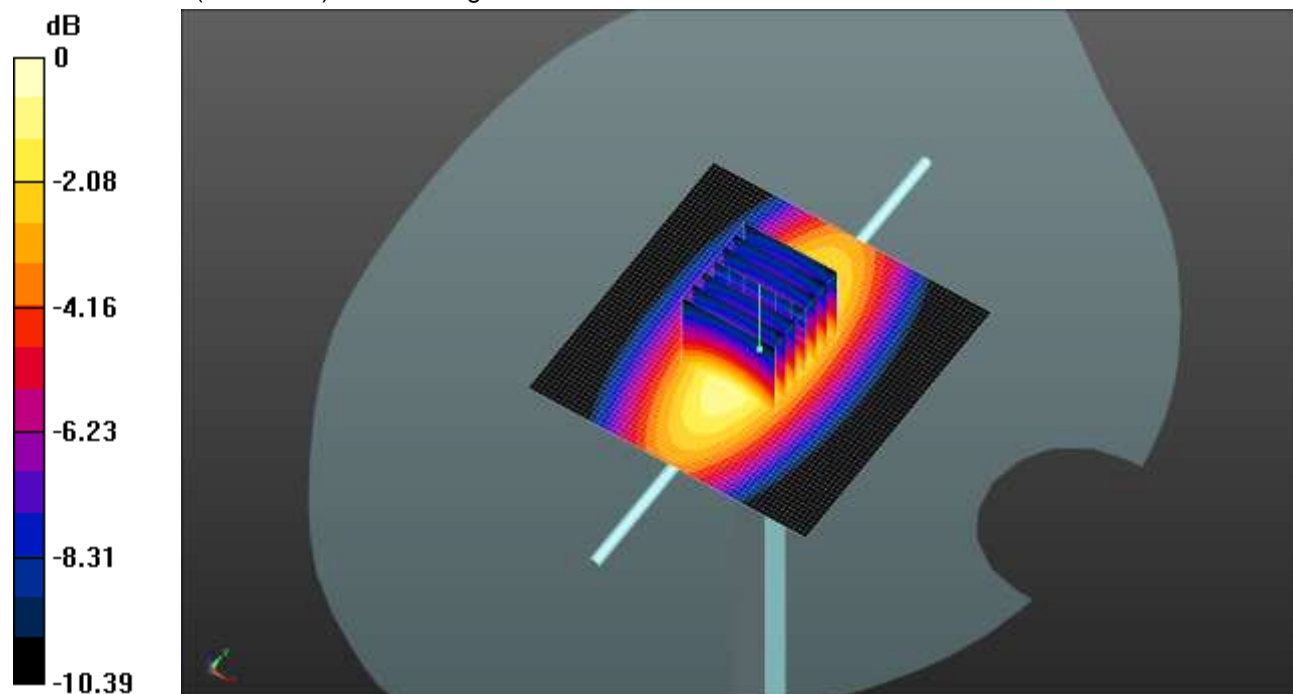

0 dB = 1.25 W/kg = 0.97 dBW/kg

20130205 SystemPerformanceCheck-D835V2 SN 4d117

Frequency: 835 MHz; Duty Cycle: 1:1

Body/Pin=100 mW/Z Scan (1x1x21): Measurement grid: dx=20mm, dy=20mm, dz=5mm
Maximum value of SAR (measured) = 1.25 W/kg

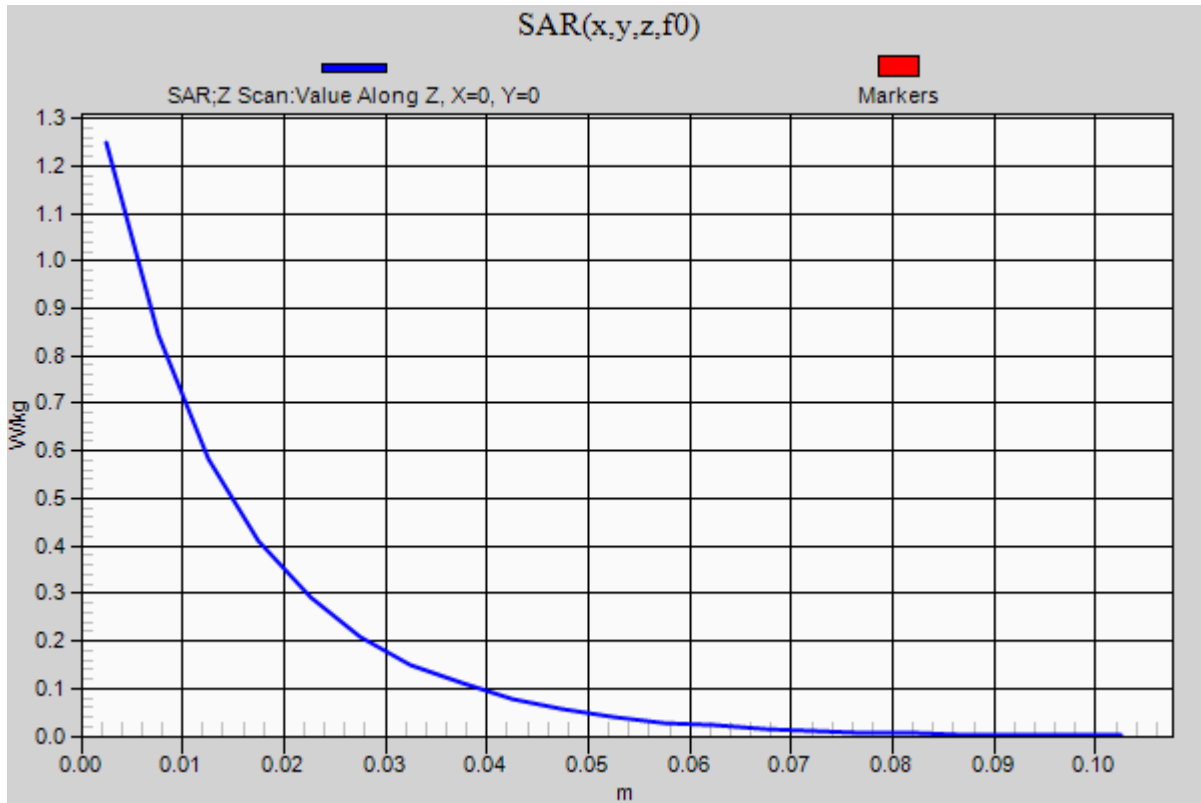

20130205 SystemPerformanceCheck-D1900V2 SN 5d140

Frequency: 1900 MHz; Duty Cycle: 1:1; Room Ambient Temperature: 23.0°C; Liquid Temperature: 22.0°C
Medium parameters used: $f = 1900$ MHz; $\sigma = 1.5$ mho/m; $\epsilon_r = 53.224$; $\rho = 1000$ kg/m³

DASY5 Configuration:

- Area Scan Setting: Find Secondary Maximum Within: 2.0 dB and with a peak SAR value greater than 0.0012W/kg
- Averaged Fast SAR: Polynomial fit
- Electronics: DAE3 Sn427; Calibrated: 1/9/2013
- Probe: EX3DV4 - SN3686; ConvF(7.04, 7.04, 7.04); Calibrated: 2/16/2012;
- Sensor-Surface: 2.5mm (Mechanical Surface Detection)
- Phantom: SAM; Type: QD000P40CD; Serial: 1629

Body/Pin=100 mW/Area Scan (61x61x1): Interpolated grid: dx=1.500 mm, dy=1.500 mm

Reference Value = 56.693 V/m; Power Drift = 0.11 dB

Fast SAR: SAR(1 g) = 3.87 W/kg; SAR(10 g) = 1.96 W/kg

Maximum value of SAR (interpolated) = 5.26 W/kg

Body/Pin=100 mW/Zoom Scan (7x7x7)/Cube 0: Measurement grid: dx=5mm, dy=5mm, dz=5mm

Reference Value = 56.693 V/m; Power Drift = 0.11 dB

Peak SAR (extrapolated) = 7.27 W/kg

SAR(1 g) = 4.03 W/kg; SAR(10 g) = 2.11 W/kg

Maximum value of SAR (measured) = 5.43 W/kg

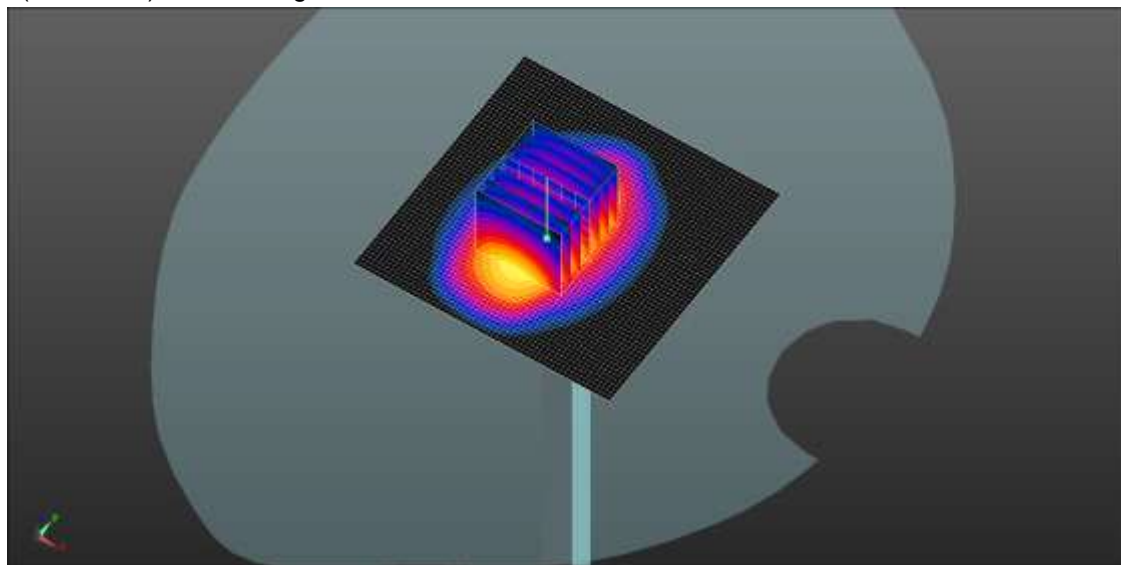
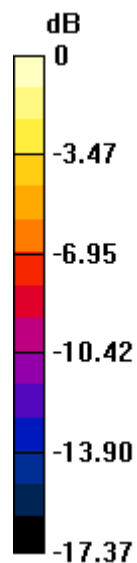

0 dB = 5.43 W/kg = 7.35 dBW/kg

20130205 SystemPerformanceCheck-D1900V2 SN 5d140

Frequency: 1900 MHz; Duty Cycle: 1:1

Body/Pin=100 mW/Z Scan (1x1x21): Measurement grid: dx=20mm, dy=20mm, dz=5mm
Maximum value of SAR (measured) = 4.77 W/kg

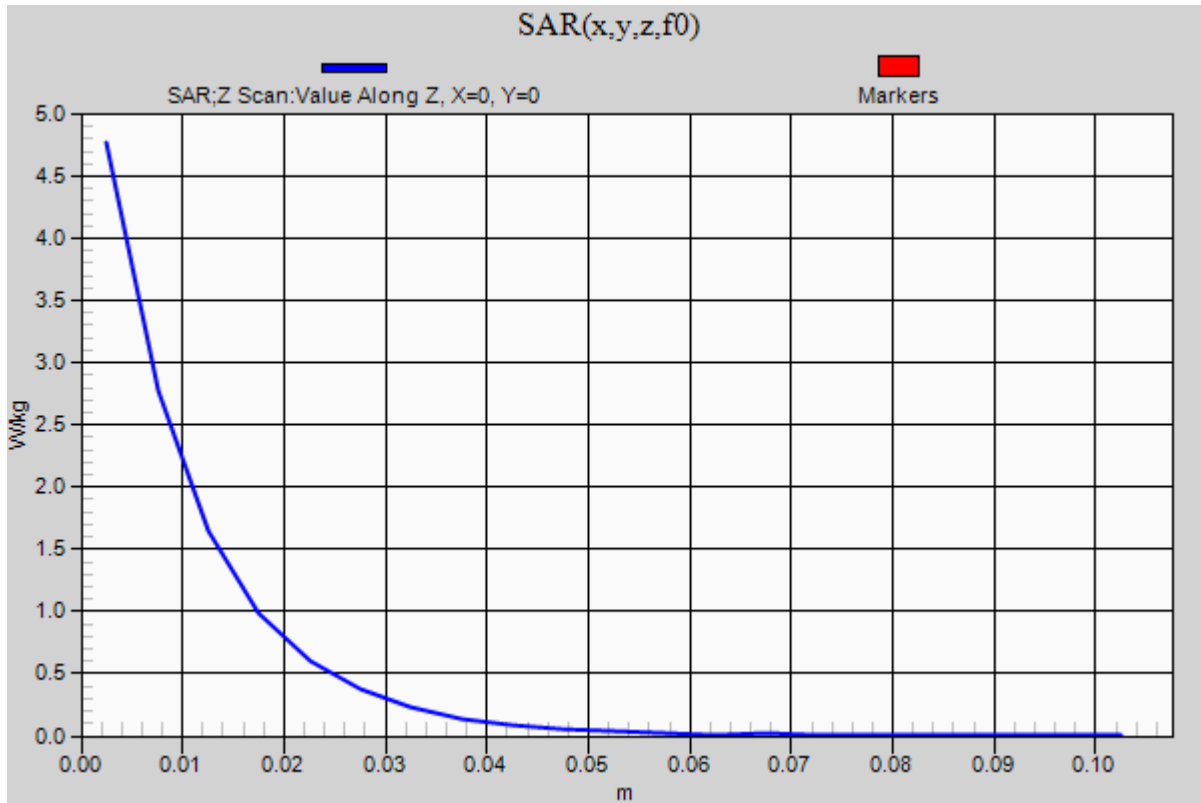

20130211 SystemPerformanceCheck-D750V3 SN 1071

Frequency: 750 MHz; Duty Cycle: 1:1; Room Ambient Temperature: 23.0°C; Liquid Temperature: 22.0°C
Medium parameters used: $f = 750$ MHz; $\sigma = 1.05$ mho/m; $\epsilon_r = 52.773$; $\rho = 1000$ kg/m³

DASY5 Configuration:

- Area Scan Setting: Find Secondary Maximum Within: 2.0 dB and with a peak SAR value greater than 0.0012W/kg
- Averaged Fast SAR: Polynomial fit
- Electronics: DAE4 Sn1343; Calibrated: 8/20/2012
- Probe: EX3DV4 - SN3871; ConvF(9.75, 9.75, 9.75); Calibrated: 8/20/2012;
- Sensor-Surface: 2.5mm (Mechanical Surface Detection)
- Phantom: ELI v5.0 B; Type: QDOVA002AA; Serial: 1180

Body/Pin=100 mW/Area Scan (61x61x1): Interpolated grid: dx=1.500 mm, dy=1.500 mm

Reference Value = 33.297 V/m; Power Drift = -0.00 dB

Fast SAR: SAR(1 g) = 0.957 mW/g; SAR(10 g) = 0.648 mW/g

Maximum value of SAR (interpolated) = 1.13 W/kg

Body/Pin=100 mW/Zoom Scan (7x7x7)/Cube 0: Measurement grid: dx=5mm, dy=5mm, dz=5mm

Reference Value = 33.297 V/m; Power Drift = -0.00 dB

Peak SAR (extrapolated) = 1.369 mW/g

SAR(1 g) = 0.936 mW/g; SAR(10 g) = 0.624 mW/g

Maximum value of SAR (measured) = 1.13 W/kg

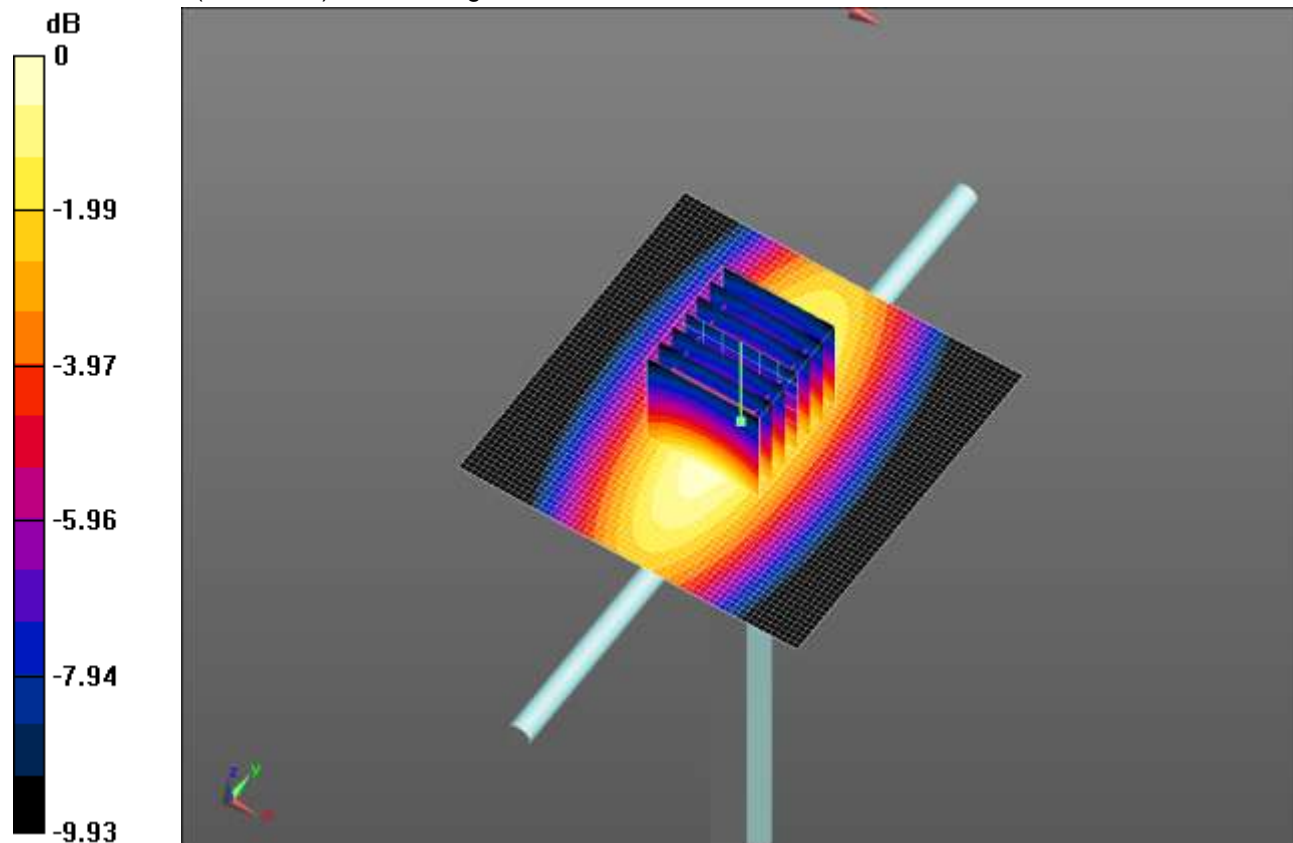

0 dB = 1.13 W/kg = 1.06 dB W/kg

20130211 SystemPerformanceCheck-D750V3 SN 1071

Frequency: 750 MHz; Duty Cycle: 1:1

Body/Pin=100 mW/Z Scan (1x1x21): Measurement grid: dx=20mm, dy=20mm, dz=5mm
Maximum value of SAR (measured) = 1.13 W/kg

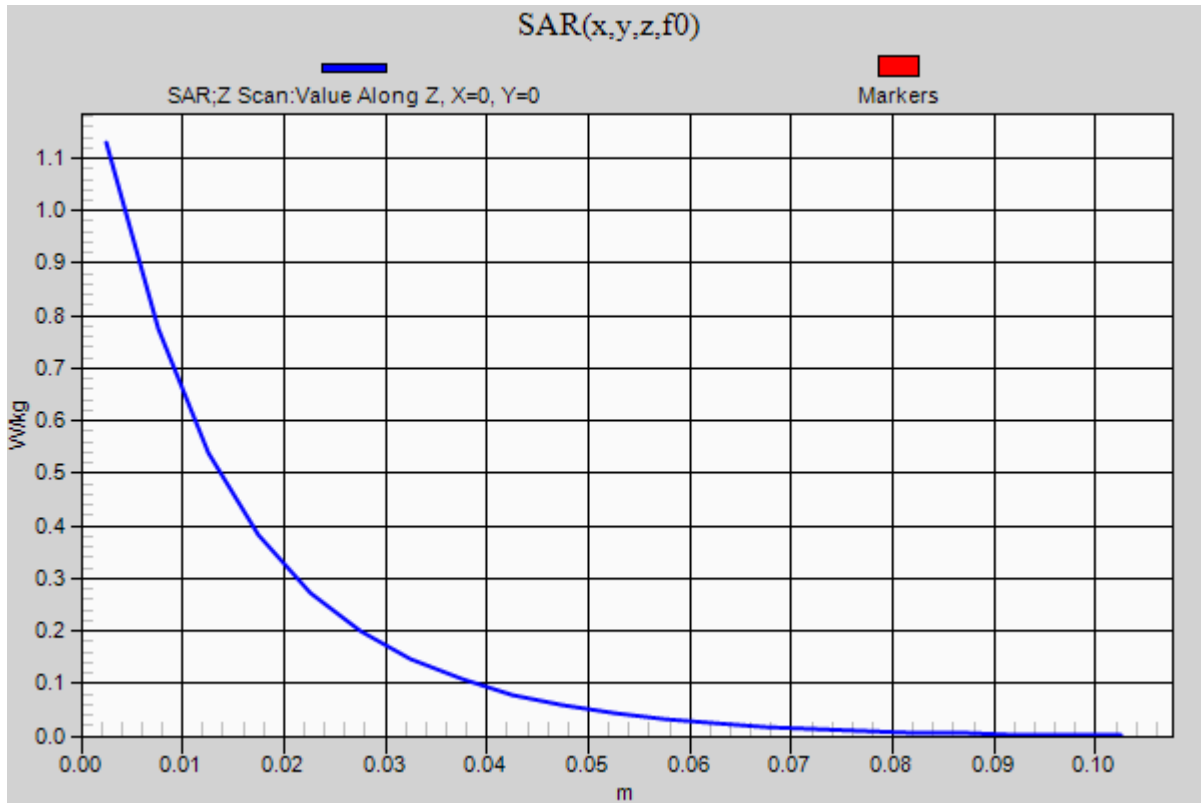

20130211 SystemPerformanceCheck-D835V2 SN 4d117

Frequency: 835 MHz; Duty Cycle: 1:1; Room Ambient Temperature: 23.0°C; Liquid Temperature: 22.0°C
Medium parameters used: $f = 835$ MHz; $\sigma = 1.014$ mho/m; $\epsilon_r = 53.786$; $\rho = 1000$ kg/m³

DASY5 Configuration:

- Area Scan Setting: Find Secondary Maximum Within: 2.0 dB and with a peak SAR value greater than 0.0012W/kg
- Averaged Fast SAR: Polynomial fit
- Electronics: DAE4 Sn1259; Calibrated: 2/13/2012
- Probe: EX3DV4 - SN3686; ConvF(8.73, 8.73, 8.73); Calibrated: 2/16/2012;
- Sensor-Surface: 2.5mm (Mechanical Surface Detection)
- Phantom: ELI v5.0 (B); Type: QDOVA001BB; Serial: 1118

Body/Pin=100 mW/Area Scan (61x61x1): Interpolated grid: dx=1.500 mm, dy=1.500 mm

Reference Value = 35.221 V/m; Power Drift = 0.04 dB

Fast SAR: SAR(1 g) = 1.06 mW/g; SAR(10 g) = 0.712 mW/g

Maximum value of SAR (interpolated) = 1.26 W/kg

Body/Pin=100 mW/Zoom Scan (7x7x7)/Cube 0: Measurement grid: dx=5mm, dy=5mm, dz=5mm

Reference Value = 35.221 V/m; Power Drift = 0.04 dB

Peak SAR (extrapolated) = 1.551 mW/g

SAR(1 g) = 1.04 mW/g; SAR(10 g) = 0.686 mW/g

Maximum value of SAR (measured) = 1.27 W/kg

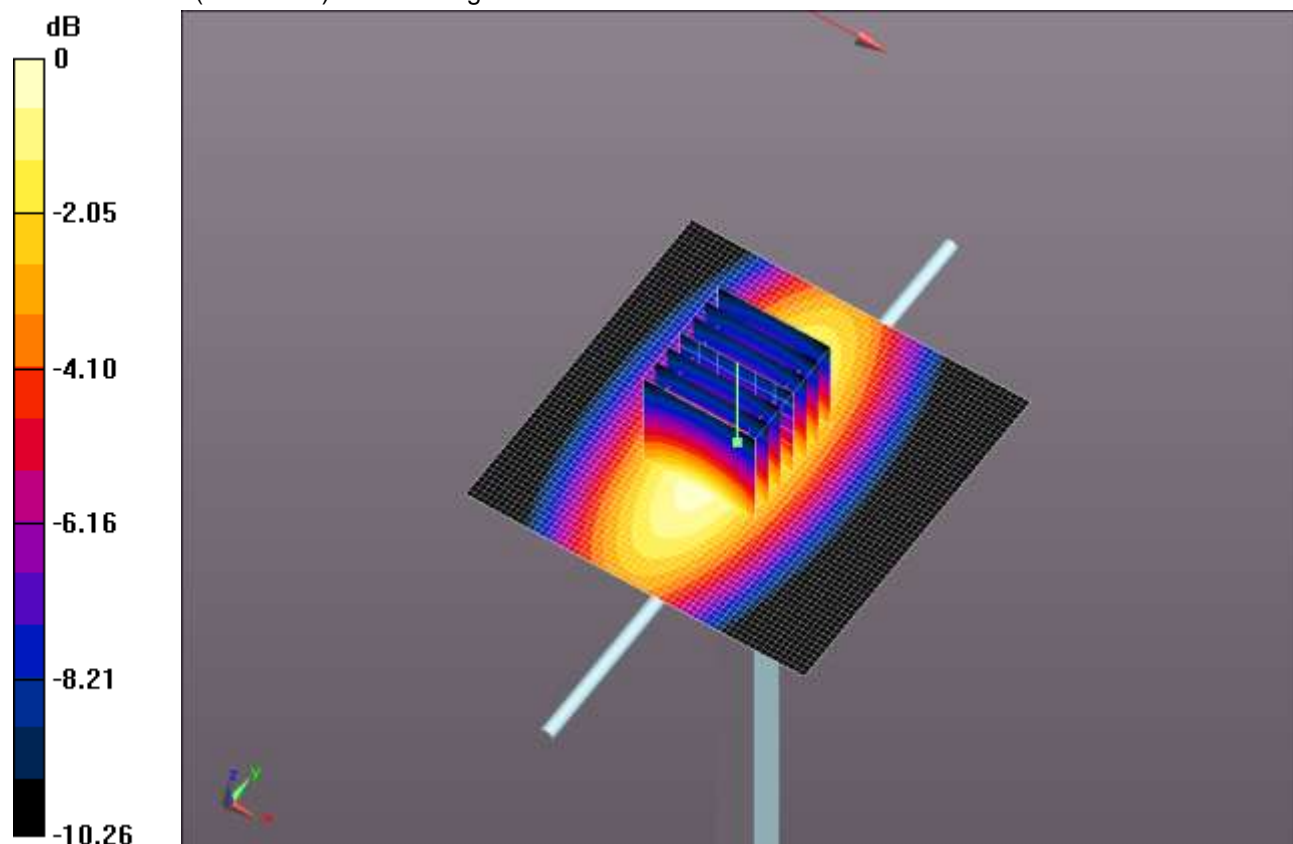

0 dB = 1.27 W/kg = 2.08 dB W/kg

20130211 SystemPerformanceCheck-D835V2 SN 4d117

Frequency: 835 MHz; Duty Cycle: 1:1

Body/Pin=100 mW/Z Scan (1x1x21): Measurement grid: dx=20mm, dy=20mm, dz=5mm
Maximum value of SAR (measured) = 1.22 W/kg

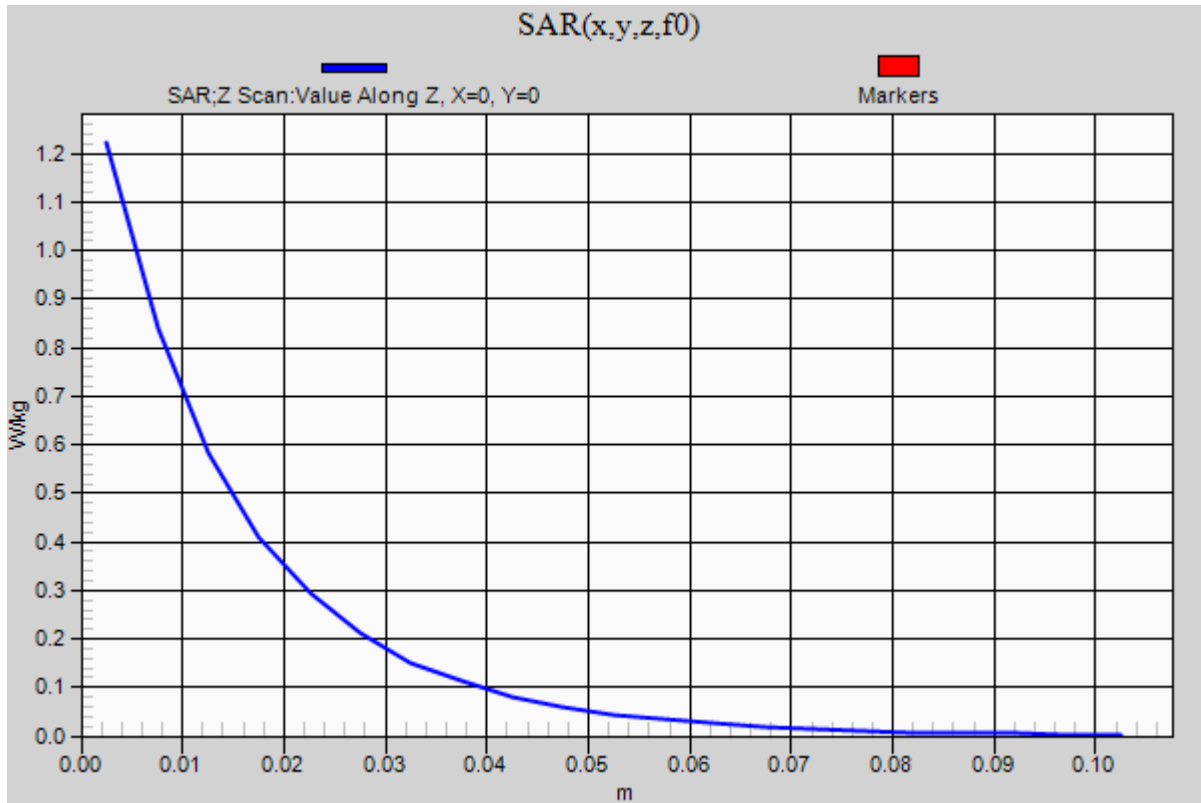

20130211 SystemPerformanceCheck-D1900V2 SN 5d140

Frequency: 1900 MHz; Duty Cycle: 1:1; Room Ambient Temperature: 23.0°C; Liquid Temperature: 22.0°C
Medium parameters used: $f = 1900$ MHz; $\sigma = 1.508$ mho/m; $\epsilon_r = 51.058$; $\rho = 1000$ kg/m³

DASY5 Configuration:

- Area Scan Setting: Find Secondary Maximum Within: 2.0 dB and with a peak SAR value greater than 0.0012W/kg
- Averaged Fast SAR: Polynomial fit
- Electronics: DAE3 Sn427; Calibrated: 1/9/2013
- Probe: EX3DV4 - SN3686; ConvF(7.04, 7.04, 7.04); Calibrated: 2/16/2012;
- Sensor-Surface: 2.5mm (Mechanical Surface Detection)
- Phantom: ELI v5.0 (A); Type: QDOVA001BB; Serial: 1120

Body/Pin=100 mW/Area Scan (61x61x1): Interpolated grid: dx=1.500 mm, dy=1.500 mm

Reference Value = 60.503 V/m; Power Drift = 0.13 dB

Fast SAR: SAR(1 g) = 4.21 mW/g; SAR(10 g) = 2.14 mW/g

Maximum value of SAR (interpolated) = 5.62 W/kg

Body/Pin=100 mW/Zoom Scan (7x7x7)/Cube 0: Measurement grid: dx=5mm, dy=5mm, dz=5mm

Reference Value = 60.503 V/m; Power Drift = 0.13 dB

Peak SAR (extrapolated) = 7.515 mW/g

SAR(1 g) = 4.19 mW/g; SAR(10 g) = 2.19 mW/g

Maximum value of SAR (measured) = 5.65 W/kg

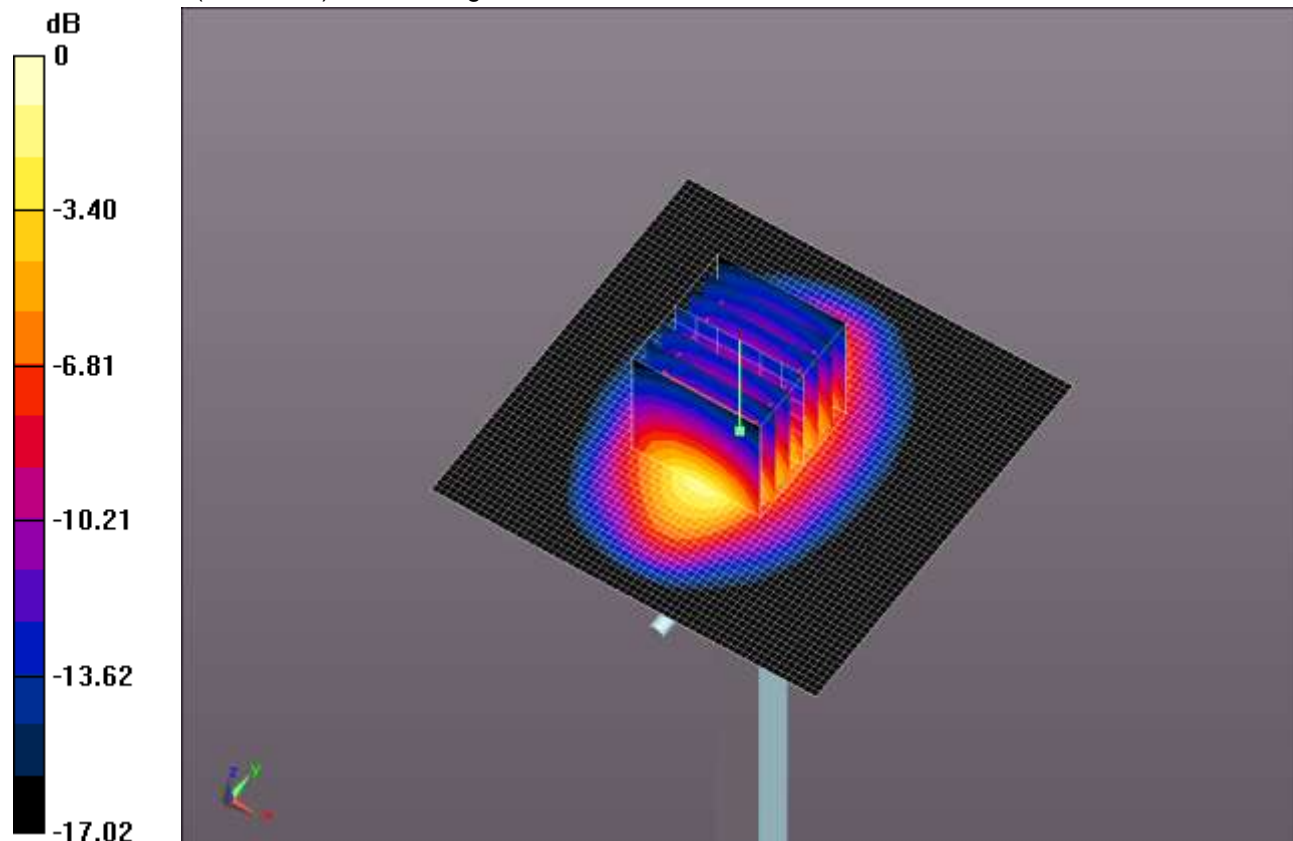

0 dB = 5.65 W/kg = 15.04 dB W/kg

20130211 SystemPerformanceCheck-D1900V2 SN 5d140

Frequency: 1900 MHz; Duty Cycle: 1:1

Body/Pin=100 mW/Z Scan (1x1x21): Measurement grid: dx=20mm, dy=20mm, dz=5mm
Maximum value of SAR (measured) = 5.42 W/kg

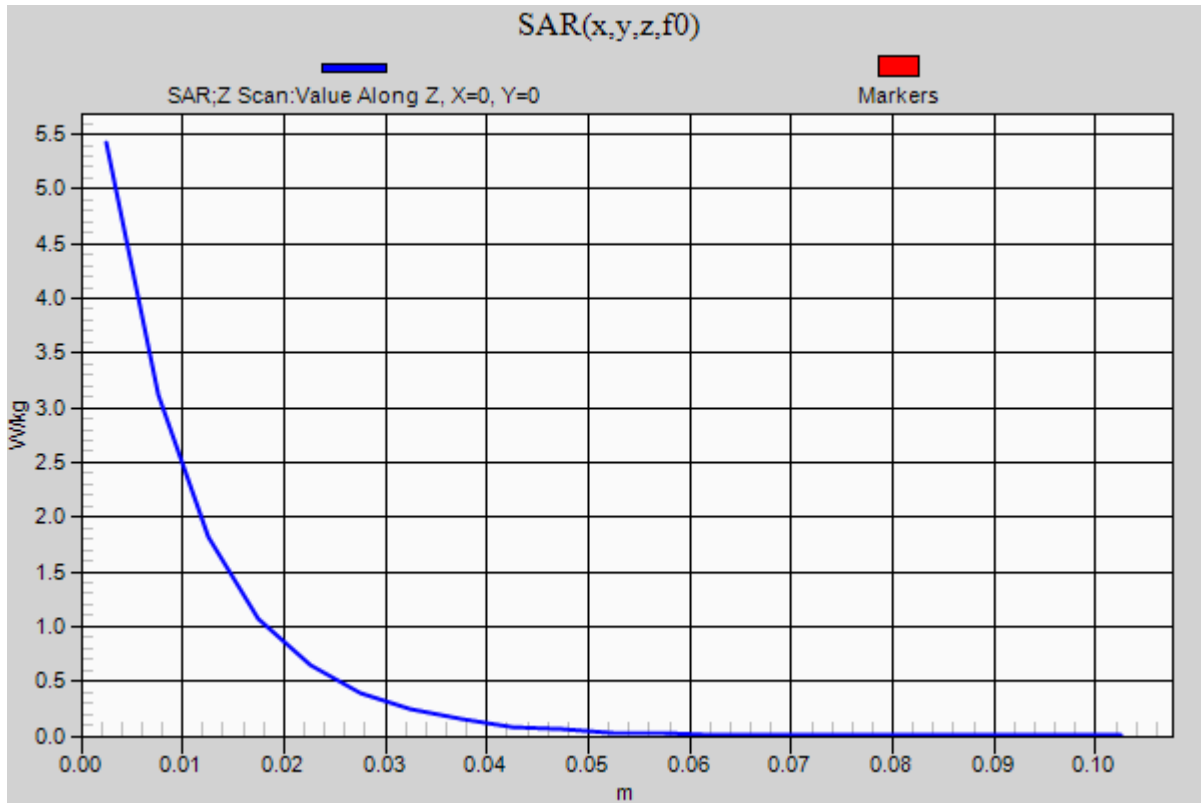

20130218 SystemPerformanceCheck-D835V2 SN 4d117

Frequency: 835 MHz; Duty Cycle: 1:1; Room Ambient Temperature: 23.0°C; Liquid Temperature: 22.0°C
Medium parameters used: $f = 835$ MHz; $\sigma = 1.015$ mho/m; $\epsilon_r = 52.773$; $\rho = 1000$ kg/m³

DASY5 Configuration:

- Area Scan Setting: Find Secondary Maximum Within: 2.0 dB and with a peak SAR value greater than 0.0012W/kg
- Averaged Fast SAR: Polynomial fit
- Electronics: DAE4 Sn1258; Calibrated: 3/8/2012
- Probe: EX3DV4 - SN3749; ConvF(8.67, 8.67, 8.67); Calibrated: 1/15/2013;
- Sensor-Surface: 2.5mm (Mechanical Surface Detection (Locations From Previous Scan Used)), Sensor-Surface: 2.5mm (Mechanical Surface Detection)
- Phantom: ELI v5.0 (B); Type: QDOVA001BB; Serial: 1118

Body/Pin=100 mW/Area Scan (61x61x1): Interpolated grid: dx=1.500 mm, dy=1.500 mm

Reference Value = 34.724 V/m; Power Drift = 0.02 dB

Fast SAR: SAR(1 g) = 1.14 W/kg; SAR(10 g) = 0.757 W/kg

Maximum value of SAR (interpolated) = 1.35 W/kg

Body/Pin=100 mW/Zoom Scan (7x7x7)/Cube 0: Measurement grid: dx=5mm, dy=5mm, dz=5mm

Reference Value = 34.724 V/m; Power Drift = 0.02 dB

Peak SAR (extrapolated) = 1.50 W/kg

SAR(1 g) = 0.997 W/kg; SAR(10 g) = 0.654 W/kg

Maximum value of SAR (measured) = 1.21 W/kg

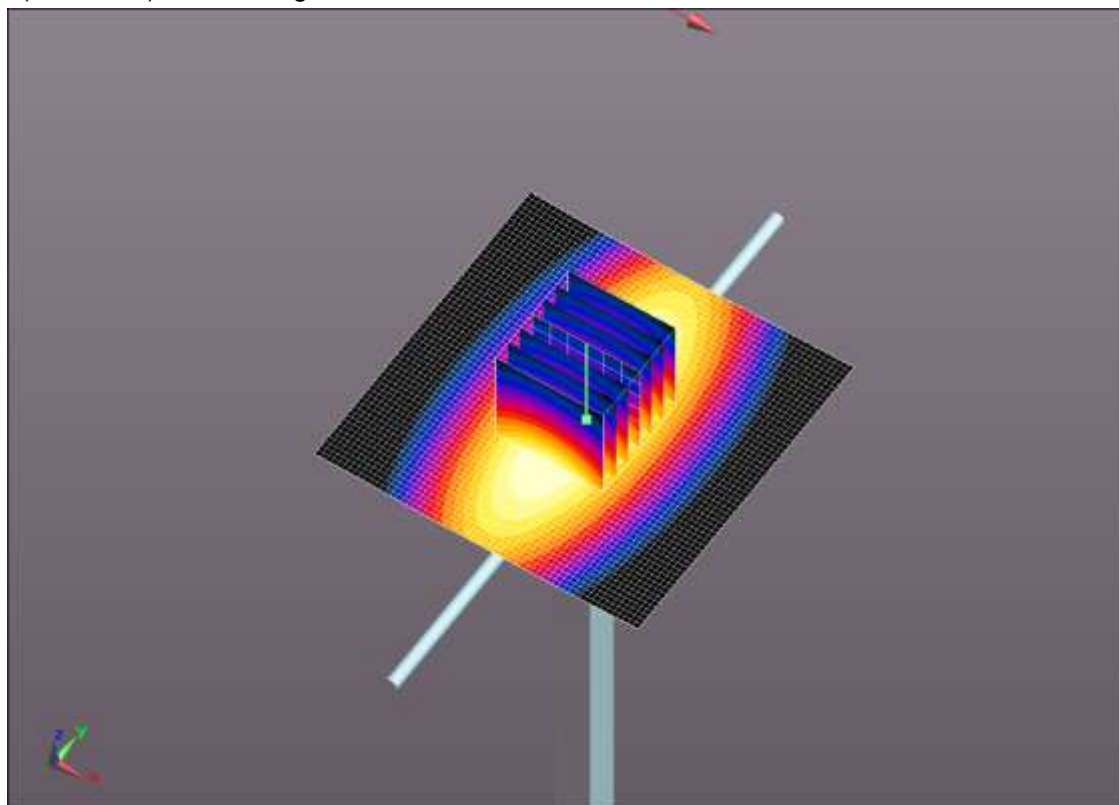
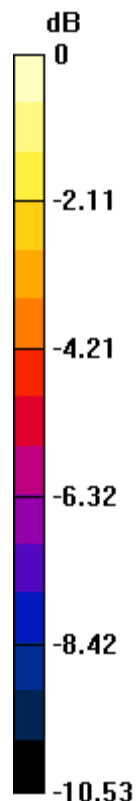

0 dB = 1.21 W/kg = 0.83 dBW/kg

20130218 SystemPerformanceCheck-D835V2 SN 4d117

Frequency: 835 MHz; Duty Cycle: 1:1

Body/Pin=100 mW/Z Scan (1x1x21): Measurement grid: dx=20mm, dy=20mm, dz=5mm
Maximum value of SAR (measured) = 1.21 W/kg

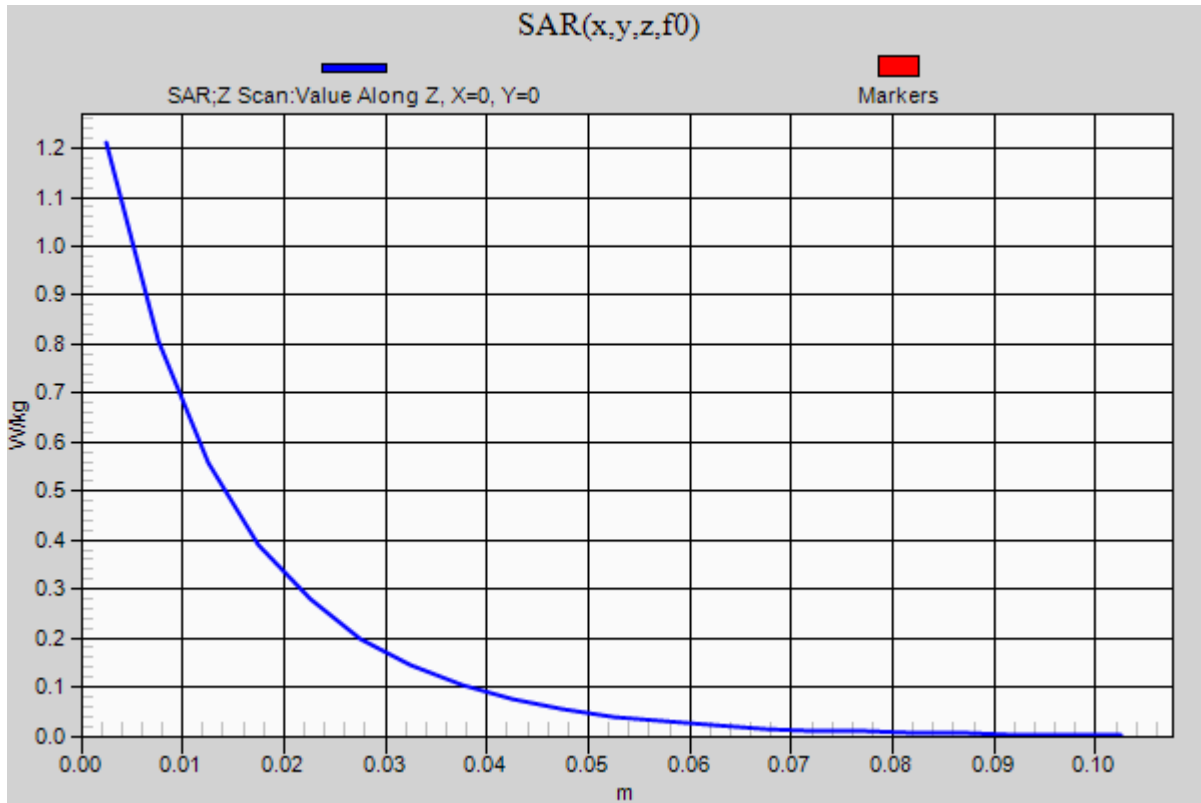

20130218 SystemPerformanceCheck-D1900V2 SN 5d043

Frequency: 1900 MHz; Duty Cycle: 1:1; Room Ambient Temperature: 23.0°C; Liquid Temperature: 22.0°C
 Medium parameters used: $f = 1900 \text{ MHz}$; $\sigma = 1.55 \text{ mho/m}$; $\epsilon_r = 51.131$; $\rho = 1000 \text{ kg/m}^3$

DASY5 Configuration:

- Area Scan Setting: Find Secondary Maximum Within: 2.0 dB and with a peak SAR value greater than 0.0012W/kg
- Electronics: DAE4 Sn1258; Calibrated: 3/8/2012
- Probe: EX3DV4 - SN3749; ConvF(6.99, 6.99, 6.99); Calibrated: 1/15/2013;
- Sensor-Surface: 2.5mm (Mechanical Surface Detection)
- Phantom: ELI v5.0 (A); Type: QDOVA001BB; Serial: 1117

Body/Pin=100 mW/Area Scan (7x7x1): Measurement grid: dx=15mm, dy=15mm

Maximum value of SAR (measured) = 5.61 W/kg

Body/Pin=100 mW/Zoom Scan (7x7x7)/Cube 0: Measurement grid: dx=5mm, dy=5mm, dz=5mm

Reference Value = 60.727 V/m; Power Drift = 0.14 dB

Peak SAR (extrapolated) = 7.87 W/kg

SAR(1 g) = 4.33 W/kg; SAR(10 g) = 2.26 W/kg

Maximum value of SAR (measured) = 5.85 W/kg

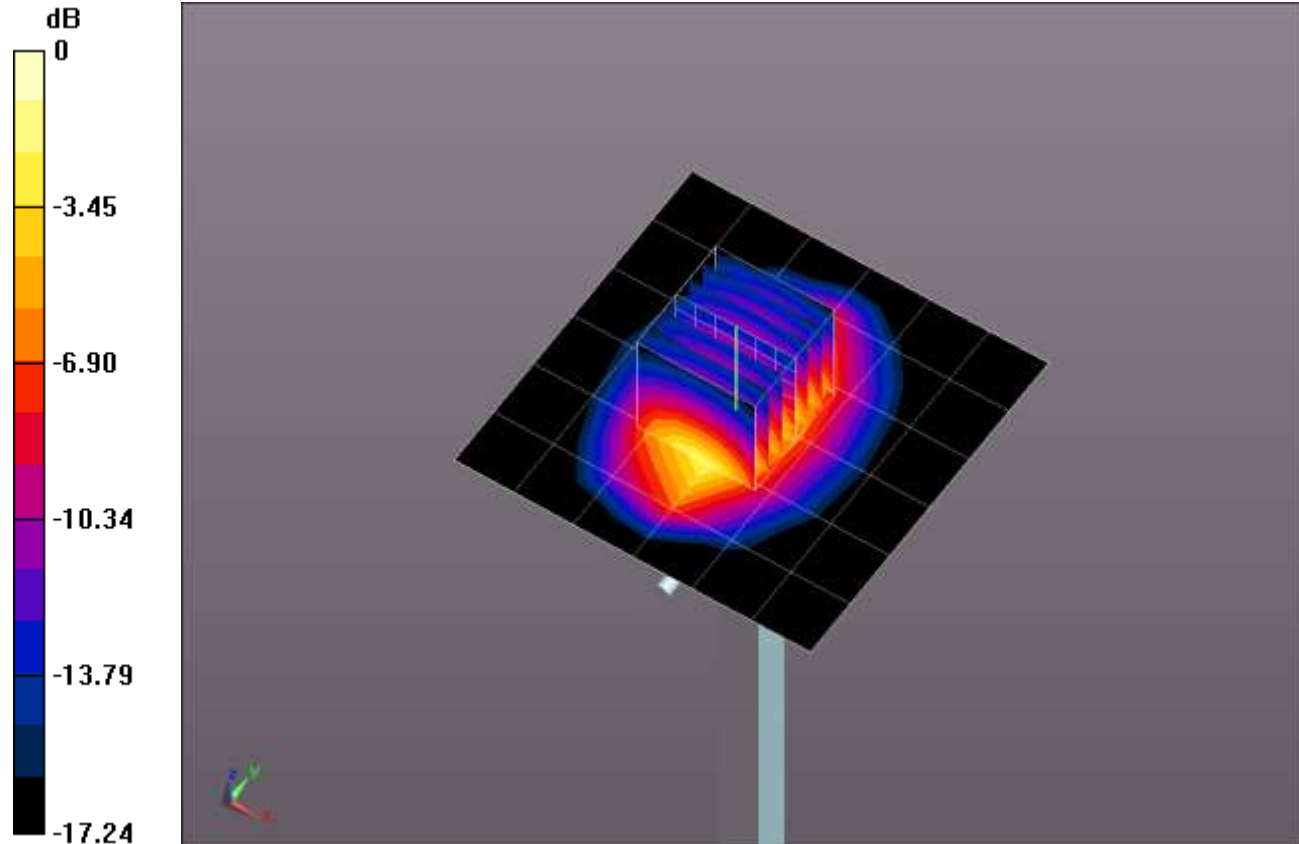

0 dB = 5.85 W/kg = 7.67 dBW/kg

20130218 SystemPerformanceCheck-D1900V2 SN 5d043

Frequency: 1900 MHz; Duty Cycle: 1:1

Body/Pin=100 mW/Z Scan (1x1x21): Measurement grid: dx=20mm, dy=20mm, dz=5mm
Maximum value of SAR (measured) = 5.61 W/kg

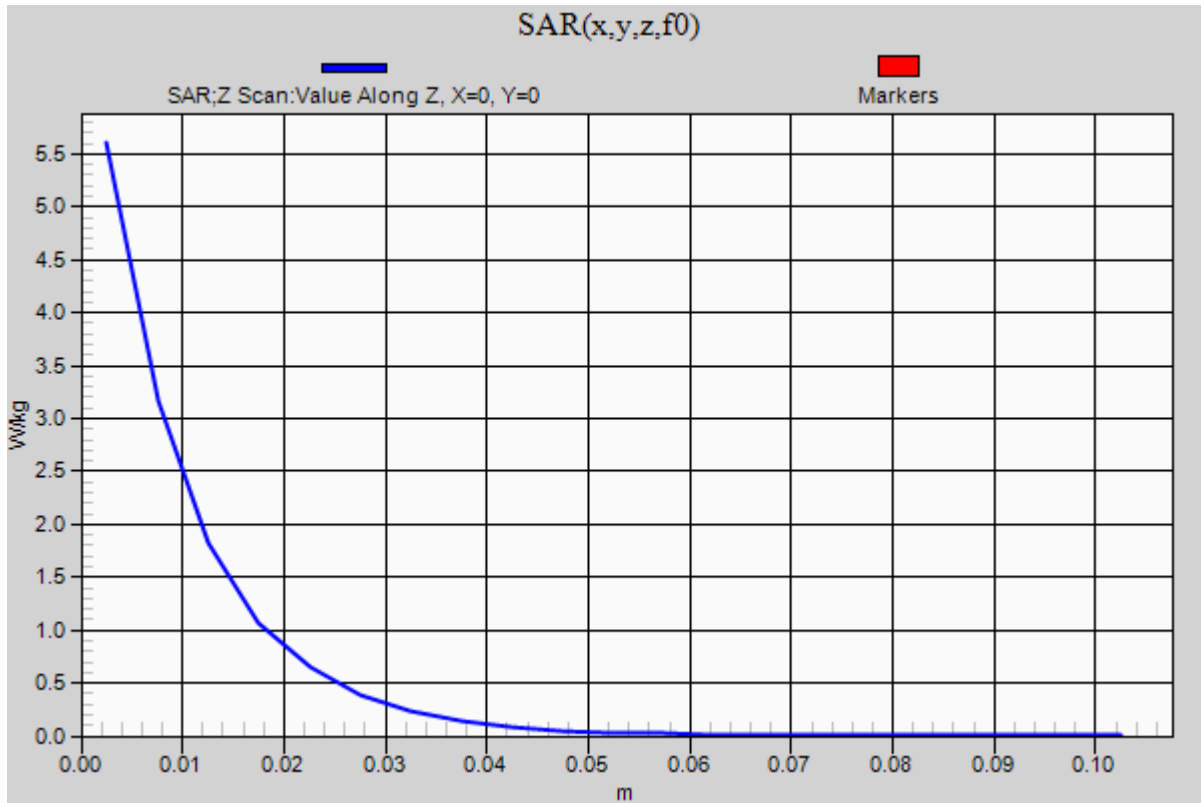

20130219 SystemPerformanceCheck-D750V3 SN 1019

Frequency: 750 MHz; Duty Cycle: 1:1; Room Ambient Temperature: 23.0°C; Liquid Temperature: 22.0°C
Medium parameters used: $f = 750$ MHz; $\sigma = 0.973$ mho/m; $\epsilon_r = 54.063$; $\rho = 1000$ kg/m³

DASY5 Configuration:

- Area Scan Setting: Find Secondary Maximum Within: 2.0 dB and with a peak SAR value greater than 0.0012W/kg
- Averaged Fast SAR: Polynomial fit
- Electronics: DAE4 Sn1352; Calibrated: 10/8/2012
- Probe: EX3DV4 - SN3885; ConvF(9.5, 9.5, 9.5); Calibrated: 10/9/2012;
- Sensor-Surface: 2.5mm (Mechanical Surface Detection)
- Phantom: ELI v5.0 (A); Type: QDOVA001BB; Serial: 1119

Body/Pin=100 mW/Area Scan (61x61x1): Interpolated grid: dx=1.500 mm, dy=1.500 mm

Reference Value = 33.676 V/m; Power Drift = 0.02 dB

Fast SAR: SAR(1 g) = 0.923 W/kg; SAR(10 g) = 0.627 W/kg

Maximum value of SAR (interpolated) = 1.09 W/kg

Body/Pin=100 mW/Zoom Scan (7x7x7)/Cube 0: Measurement grid: dx=5mm, dy=5mm, dz=5mm

Reference Value = 33.676 V/m; Power Drift = 0.02 dB

Peak SAR (extrapolated) = 1.35 W/kg

SAR(1 g) = 0.906 W/kg; SAR(10 g) = 0.603 W/kg

Maximum value of SAR (measured) = 1.10 W/kg

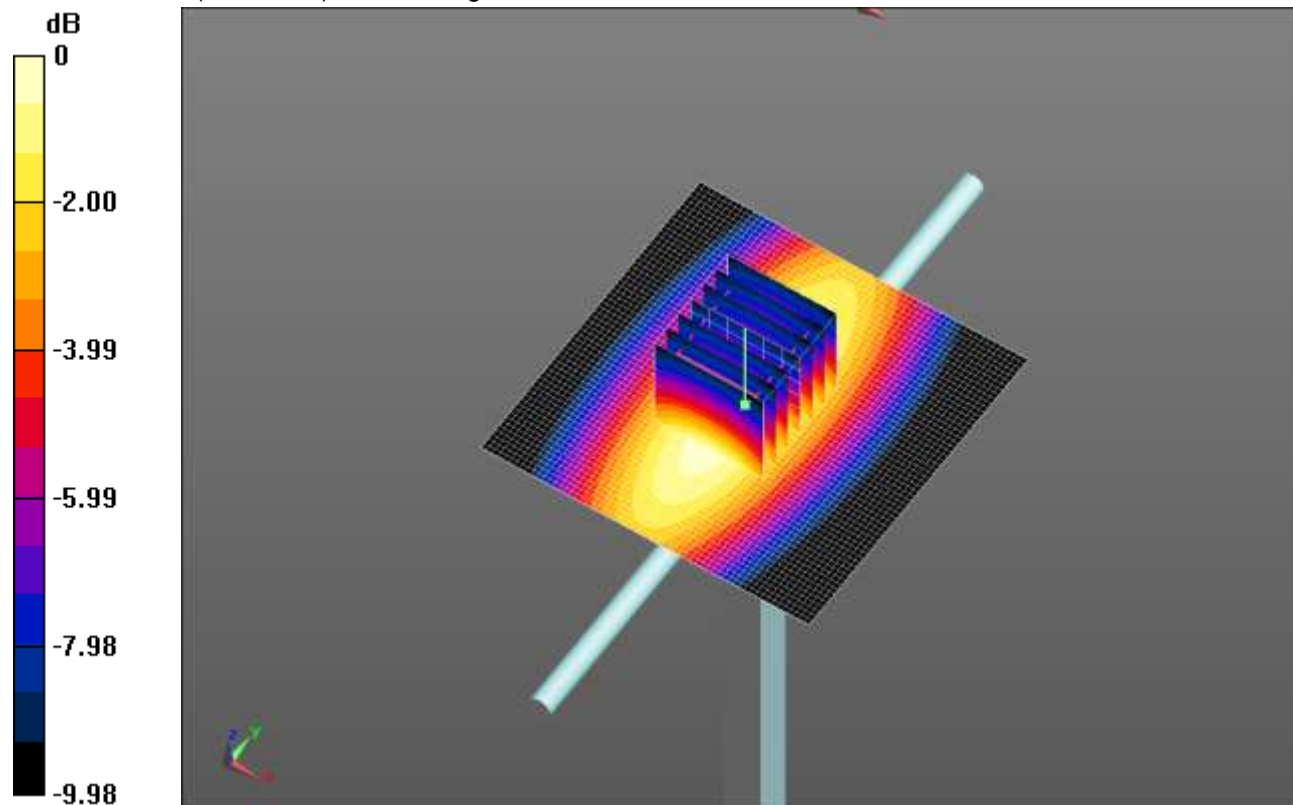

0 dB = 1.10 W/kg = 0.41 dBW/kg

20130219 SystemPerformanceCheck-D750V3 SN 1019

Frequency: 750 MHz; Duty Cycle: 1:1

Body/Pin=100 mW/Z Scan (1x1x21): Measurement grid: dx=20mm, dy=20mm, dz=5mm
Maximum value of SAR (measured) = 1.08 W/kg

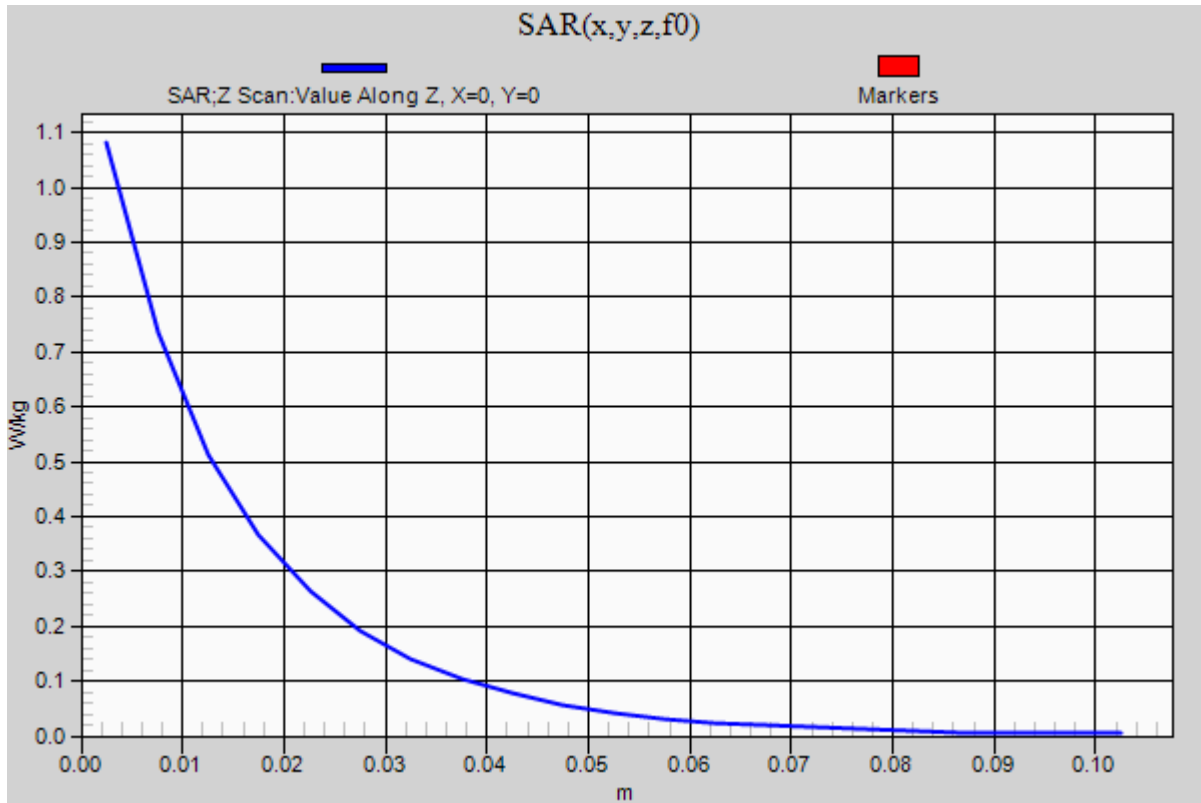

20130304 SystemPerformanceCheck-D2450V2 SN 706

Frequency: 2450 MHz; Duty Cycle: 1:1; Room Ambient Temperature: 24.0°C; Liquid Temperature: 23.0°C
Medium parameters used: $f = 2450$ MHz; $\sigma = 1.899$ S/m; $\epsilon_r = 50.691$; $\rho = 1000$ kg/m³

DASY5 Configuration:

- Area Scan Setting: Find Secondary Maximum Within: 2.0 dB and with a peak SAR value greater than 0.0012W/kg
- Averaged Fast SAR: Polynomial fit
- Electronics: DAE4 Sn1352; Calibrated: 10/8/2012
- Probe: EX3DV4 - SN3885; ConvF(6.8, 6.8, 6.8); Calibrated: 10/9/2012;
- Sensor-Surface: 2.5mm (Mechanical Surface Detection)
- Phantom: ELI v5.0 (B); Type: QDOVA001BB; Serial: 1185

Body/Pin=100 mW/Area Scan (71x71x1): Interpolated grid: dx=1.200 mm, dy=1.200 mm

Reference Value = 62.630 V/m; Power Drift = 0.00 dB

Fast SAR: SAR(1 g) = 5.31 W/kg; SAR(10 g) = 2.3 W/kg

Maximum value of SAR (interpolated) = 7.77 W/kg

Body/Pin=100 mW/Zoom Scan (7x7x7)/Cube 0: Measurement grid: dx=5mm, dy=5mm, dz=5mm

Reference Value = 62.630 V/m; Power Drift = 0.00 dB

Peak SAR (extrapolated) = 11.2 W/kg

SAR(1 g) = 5.33 W/kg; SAR(10 g) = 2.46 W/kg

Maximum value of SAR (measured) = 7.59 W/kg

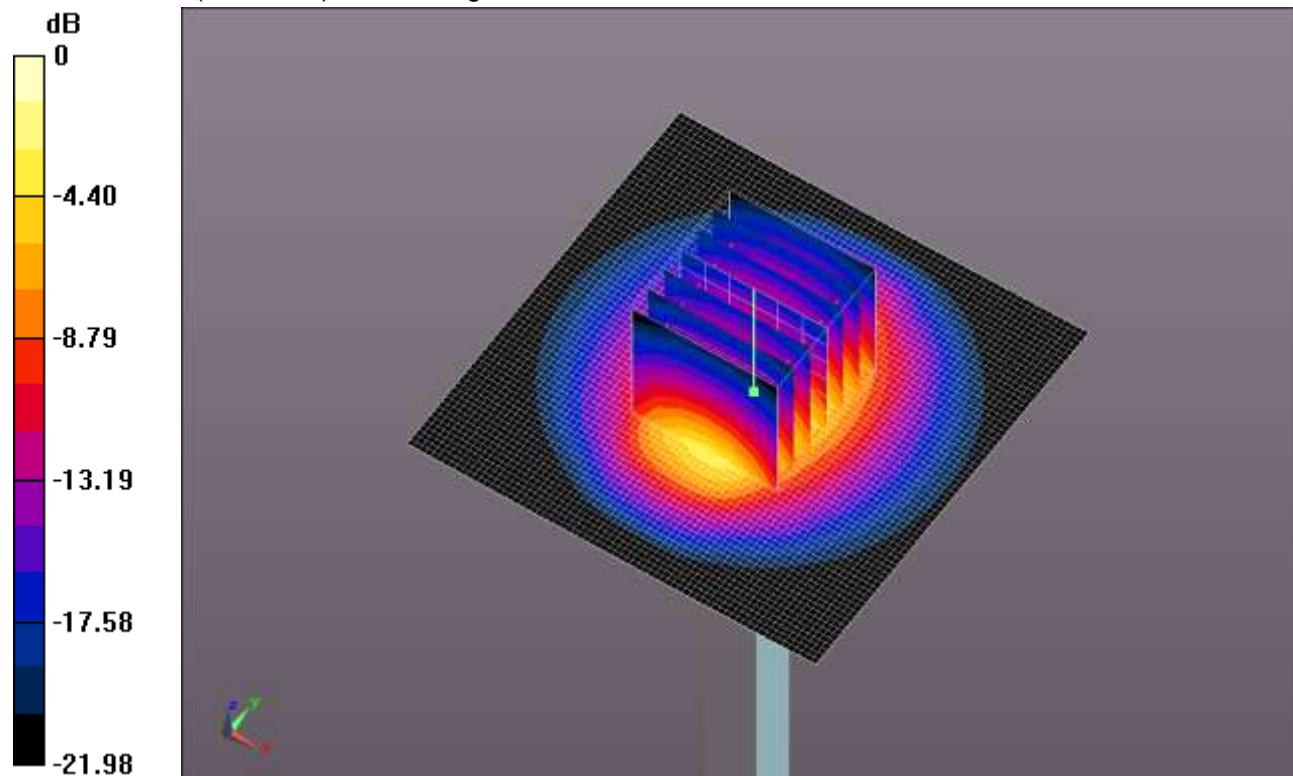

0 dB = 7.59 W/kg = 8.80 dBW/kg

20130304 SystemPerformanceCheck-D2450V2 SN 706

Frequency: 2450 MHz; Duty Cycle: 1:1

Body/Pin=100 mW/Z Scan (1x1x21): Measurement grid: dx=20mm, dy=20mm, dz=5mm
Maximum value of SAR (measured) = 7.43 W/kg

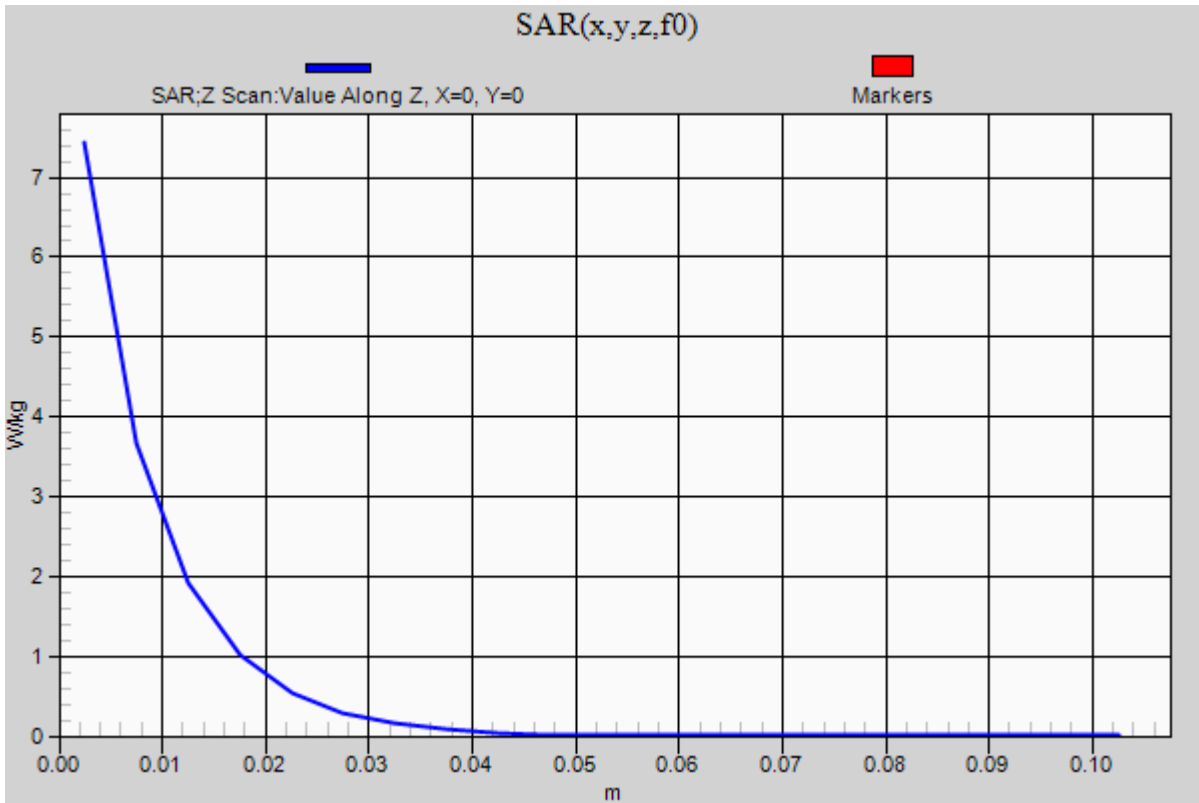

20130304 SystemPerformanceCheck-D5GHzV2 SN 1003

Frequency: 5200 MHz; Duty Cycle: 1:1; Room Ambient Temperature: 24.0°C; Liquid Temperature: 23.0°C

Medium parameters used: $f = 5200$ MHz; $\sigma = 5.14$ S/m; $\epsilon_r = 47.91$; $\rho = 1000$ kg/m³

DASY5 Configuration:

- Area Scan Setting: Find Secondary Maximum Within: 2.0 dB and with a peak SAR value greater than 0.0012W/kg
- Averaged Fast SAR: Polynomial fit
- Electronics: DAE3 Sn427; Calibrated: 1/9/2013
- Probe: EX3DV4 - SN3751; ConvF(4.26, 4.26, 4.26); Calibrated: 11/15/2012;
- Sensor-Surface: 1.4mm (Mechanical Surface Detection)
- Phantom: ELI v5.0 (B); Type: QDOVA001BB; Serial: 1118

Body/5.2 GHz, Pin=100mW/Area Scan (61x61x1): Interpolated grid: dx=1.000 mm, dy=1.000 mm

Reference Value = 52.970 V/m; Power Drift = 0.14 dB

Fast SAR: SAR(1 g) = 7.75 W/kg; SAR(10 g) = 2.15 W/kg

Maximum value of SAR (interpolated) = 20.1 W/kg

Body/5.2 GHz, Pin=100mW/Zoom Scan (8x8x7)/Cube 0: Measurement grid: dx=4mm, dy=4mm, dz=1.4mm

Reference Value = 52.970 V/m; Power Drift = 0.14 dB

Peak SAR (extrapolated) = 34.9 W/kg

SAR(1 g) = 8.12 W/kg; SAR(10 g) = 2.27 W/kg

Maximum value of SAR (measured) = 19.6 W/kg

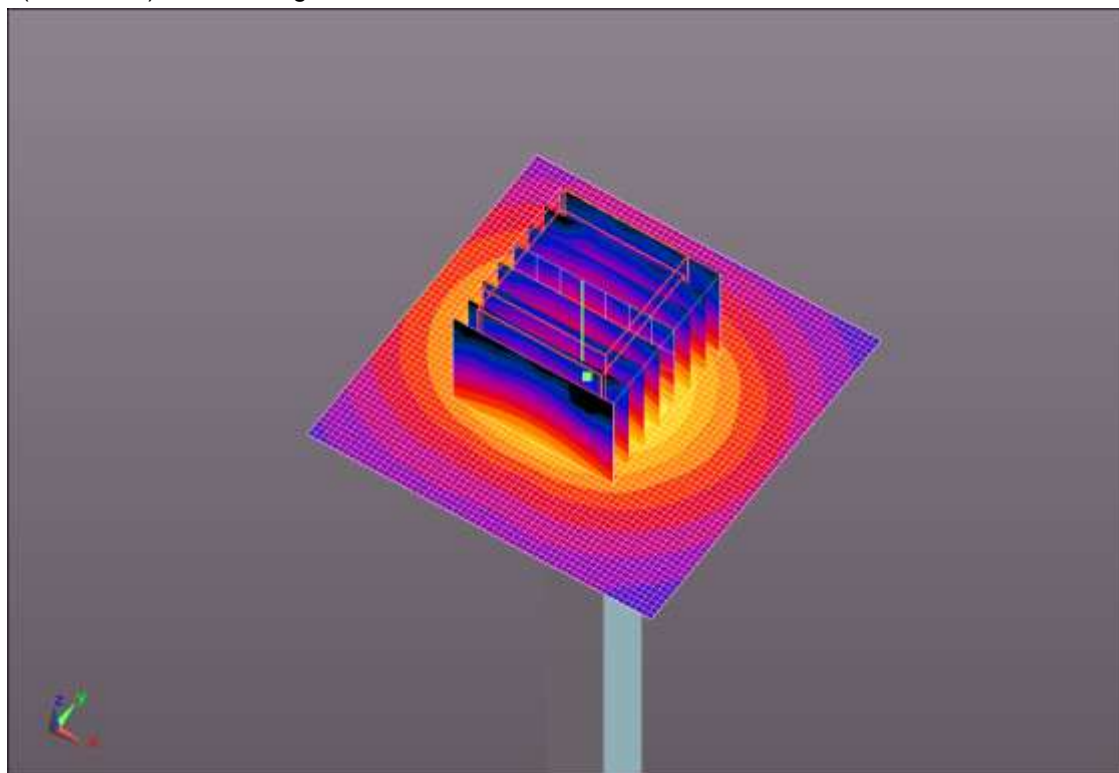
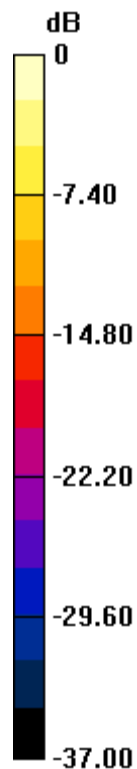

0 dB = 19.6 W/kg = 12.92 dBW/kg

20130304 SystemPerformanceCheck-D5GHzV2 SN 1003

Frequency: 5200 MHz; Duty Cycle: 1:1

Body/5.2 GHz, Pin=100mW/Z Scan (1x1x21): Measurement grid: dx=20mm, dy=20mm, dz=5mm
Maximum value of SAR (measured) = 13.0 W/kg

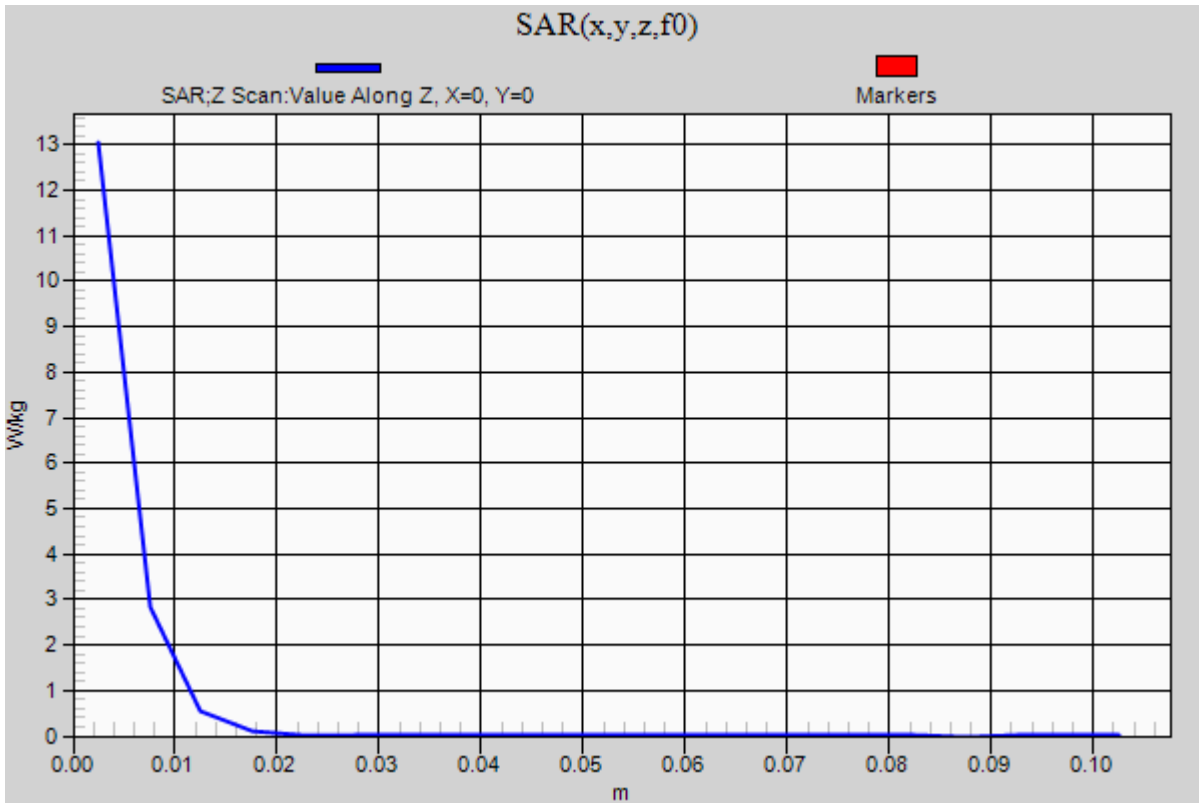

20130304 SystemPerformanceCheck-D5GHzV2 SN 1003

Frequency: 5600 MHz; Duty Cycle: 1:1; Room Ambient Temperature: 24.0°C; Liquid Temperature: 23.0°C

Medium parameters used: $f = 5600$ MHz; $\sigma = 5.644$ S/m; $\epsilon_r = 47.35$; $\rho = 1000$ kg/m³

DASY5 Configuration:

- Area Scan Setting: Find Secondary Maximum Within: 2.0 dB and with a peak SAR value greater than 0.0012W/kg
- Averaged Fast SAR: Polynomial fit
- Electronics: DAE3 Sn427; Calibrated: 1/9/2013
- Probe: EX3DV4 - SN3751; ConvF(3.63, 3.63, 3.63); Calibrated: 11/15/2012;
- Sensor-Surface: 1.4mm (Mechanical Surface Detection)
- Phantom: ELI v5.0 (B); Type: QDOVA001BB; Serial: 1118

Body/5.6 GHz, Pin=100mW/Area Scan (61x61x1): Interpolated grid: dx=1.000 mm, dy=1.000 mm

Reference Value = 52.106 V/m; Power Drift = 0.14 dB

Fast SAR: SAR(1 g) = 7.99 W/kg; SAR(10 g) = 2.19 W/kg

Maximum value of SAR (interpolated) = 21.6 W/kg

Body/5.6 GHz, Pin=100mW/Zoom Scan (8x8x7)/Cube 0: Measurement grid: dx=4mm, dy=4mm, dz=1.4mm

Reference Value = 52.106 V/m; Power Drift = 0.14 dB

Peak SAR (extrapolated) = 39.2 W/kg

SAR(1 g) = 8.42 W/kg; SAR(10 g) = 2.34 W/kg

Maximum value of SAR (measured) = 20.9 W/kg

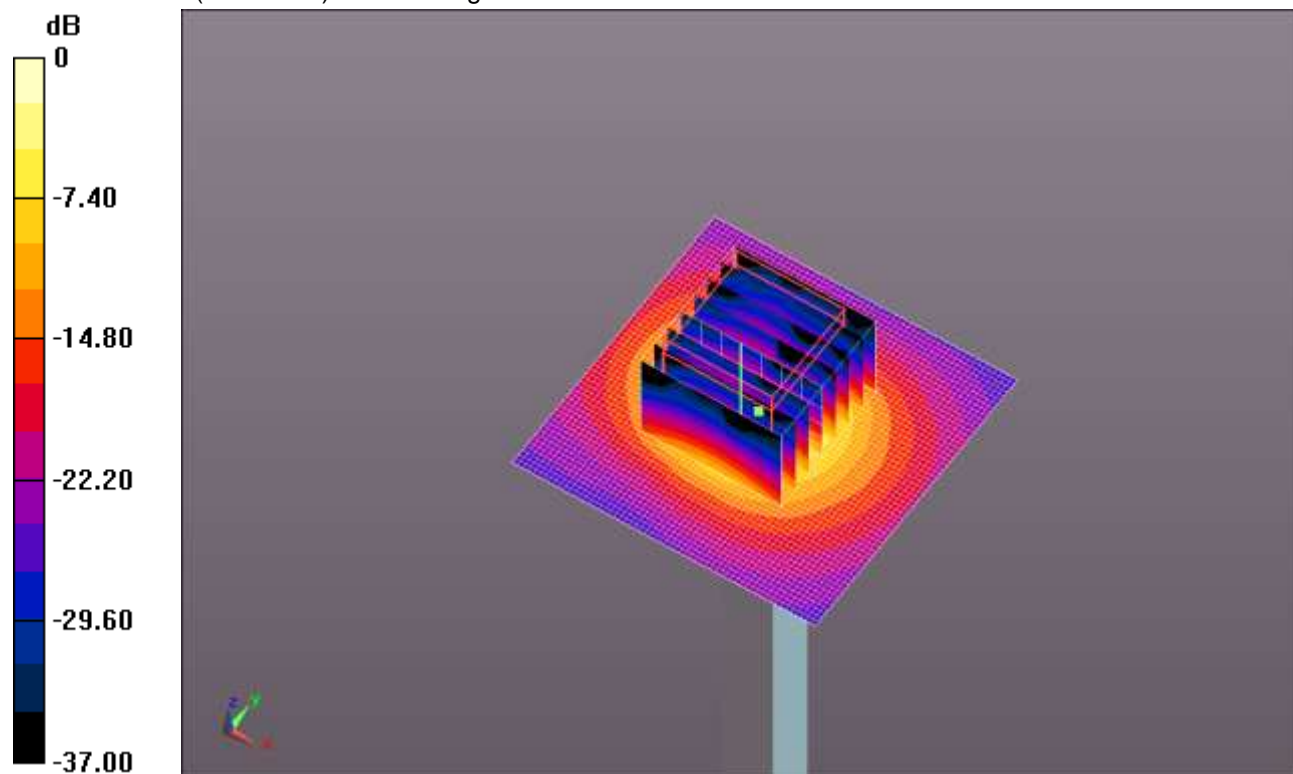

0 dB = 20.9 W/kg = 13.20 dBW/kg

20130304 SystemPerformanceCheck-D5GHzV2 SN 1003

Frequency: 5600 MHz; Duty Cycle: 1:1

Body/5.6 GHz, Pin=100mW/Z Scan (1x1x21): Measurement grid: dx=20mm, dy=20mm, dz=5mm
Maximum value of SAR (measured) = 13.5 W/kg

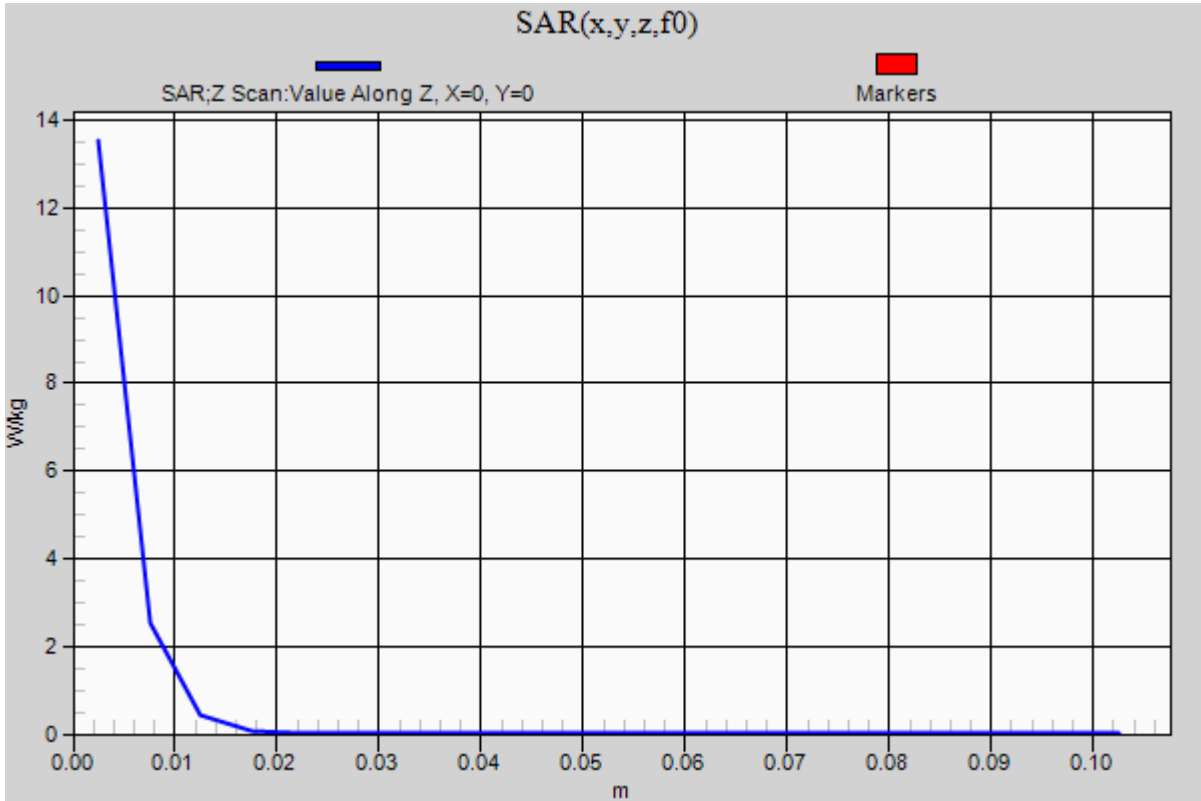

20130304 SystemPerformanceCheck-D5GHzV2 SN 1003

Frequency: 5800 MHz; Duty Cycle: 1:1; Room Ambient Temperature: 24.0°C; Liquid Temperature: 23.0°C

Medium parameters used: $f = 5800$ MHz; $\sigma = 5.912$ S/m; $\epsilon_r = 47.064$; $\rho = 1000$ kg/m³

DASY5 Configuration:

- Area Scan Setting: Find Secondary Maximum Within: 2.0 dB and with a peak SAR value greater than 0.0012W/kg
- Averaged Fast SAR: Polynomial fit
- Electronics: DAE3 Sn427; Calibrated: 1/9/2013
- Probe: EX3DV4 - SN3751; ConvF(3.88, 3.88, 3.88); Calibrated: 11/15/2012;
- Sensor-Surface: 1.4mm (Mechanical Surface Detection (Locations From Previous Scan Used)), Sensor-Surface: 1.4mm (Mechanical Surface Detection)
- Phantom: ELI v5.0 (B); Type: QDOVA001BB; Serial: 1118

Body/5.8 GHz, Pin=100mW/Area Scan (61x61x1): Interpolated grid: dx=1.000 mm, dy=1.000 mm

Reference Value = 48.755 V/m; Power Drift = 0.12 dB

Fast SAR: SAR(1 g) = 7.51 W/kg; SAR(10 g) = 2.06 W/kg

Maximum value of SAR (interpolated) = 20.9 W/kg

Body/5.8 GHz, Pin=100mW/Zoom Scan (8x8x7)/Cube 0: Measurement grid: dx=4mm, dy=4mm,

dz=1.4mm

Reference Value = 48.755 V/m; Power Drift = 0.12 dB

Peak SAR (extrapolated) = 35.9 W/kg

SAR(1 g) = 7.57 W/kg; SAR(10 g) = 2.12 W/kg

Maximum value of SAR (measured) = 18.9 W/kg

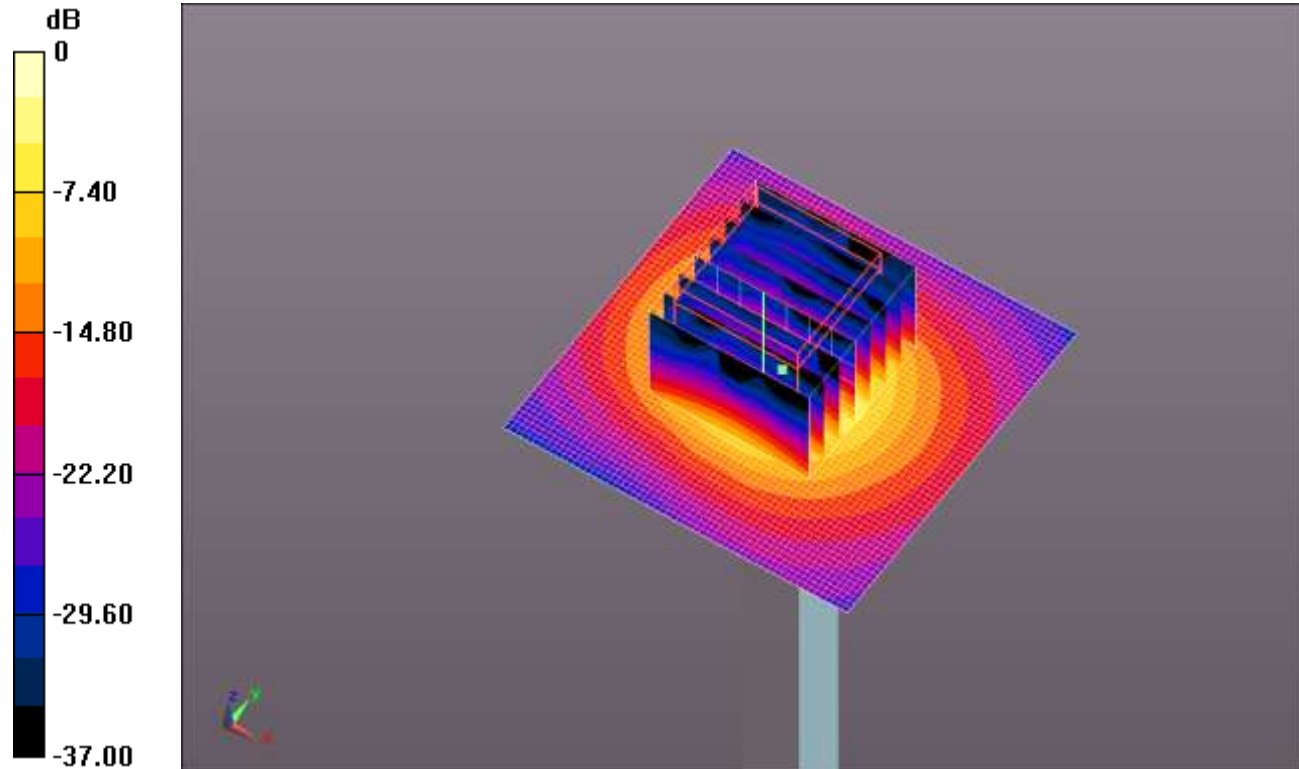

0 dB = 18.9 W/kg = 12.76 dBW/kg

20130304 SystemPerformanceCheck-D5GHzV2 SN 1003

Frequency: 5800 MHz; Duty Cycle: 1:1

Body/5.8 GHz, Pin=100mW/Z Scan (1x1x21): Measurement grid: dx=20mm, dy=20mm, dz=5mm
Maximum value of SAR (measured) = 12.2 W/kg

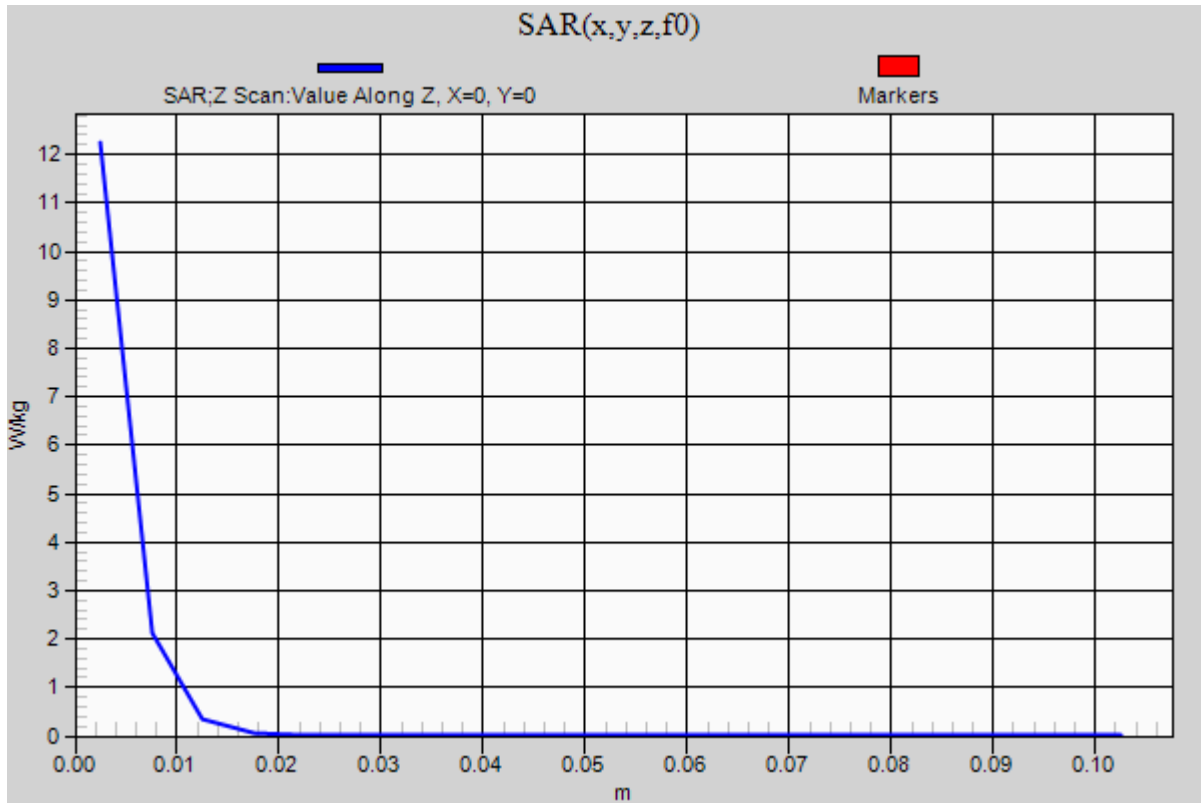

20130305 SystemPerformanceCheck-D1900V2 SN 5d043

Frequency: 1900 MHz; Duty Cycle: 1:1; Room Ambient Temperature: 24.0°C; Liquid Temperature: 23.0°C
 Medium parameters used: $f = 1900 \text{ MHz}$; $\sigma = 1.548 \text{ mho/m}$; $\epsilon_r = 52.081$; $\rho = 1000 \text{ kg/m}^3$

DASY5 Configuration:

- Area Scan Setting: Find Secondary Maximum Within: 2.0 dB and with a peak SAR value greater than 0.0012W/kg
- Averaged Fast SAR: Polynomial fit
- Electronics: DAE4 Sn1258; Calibrated: 3/8/2012
- Probe: EX3DV4 - SN3749; ConvF(6.99, 6.99, 6.99); Calibrated: 1/15/2013;
- Sensor-Surface: 2.5mm (Mechanical Surface Detection)
- Phantom: ELI v5.0 (A); Type: QDOVA001BB; Serial: 1119

Body/Pin=100 mW/Area Scan (61x61x1): Interpolated grid: dx=1.500 mm, dy=1.500 mm

Reference Value = 60.568 V/m; Power Drift = 0.04 dB

Fast SAR: SAR(1 g) = 4.18 W/kg; SAR(10 g) = 2.09 W/kg

Maximum value of SAR (interpolated) = 5.60 W/kg

Body/Pin=100 mW/Zoom Scan (7x7x7)/Cube 0: Measurement grid: dx=5mm, dy=5mm, dz=5mm

Reference Value = 60.568 V/m; Power Drift = 0.04 dB

Peak SAR (extrapolated) = 7.49 W/kg

SAR(1 g) = 4.14 W/kg; SAR(10 g) = 2.16 W/kg

Maximum value of SAR (measured) = 5.61 W/kg

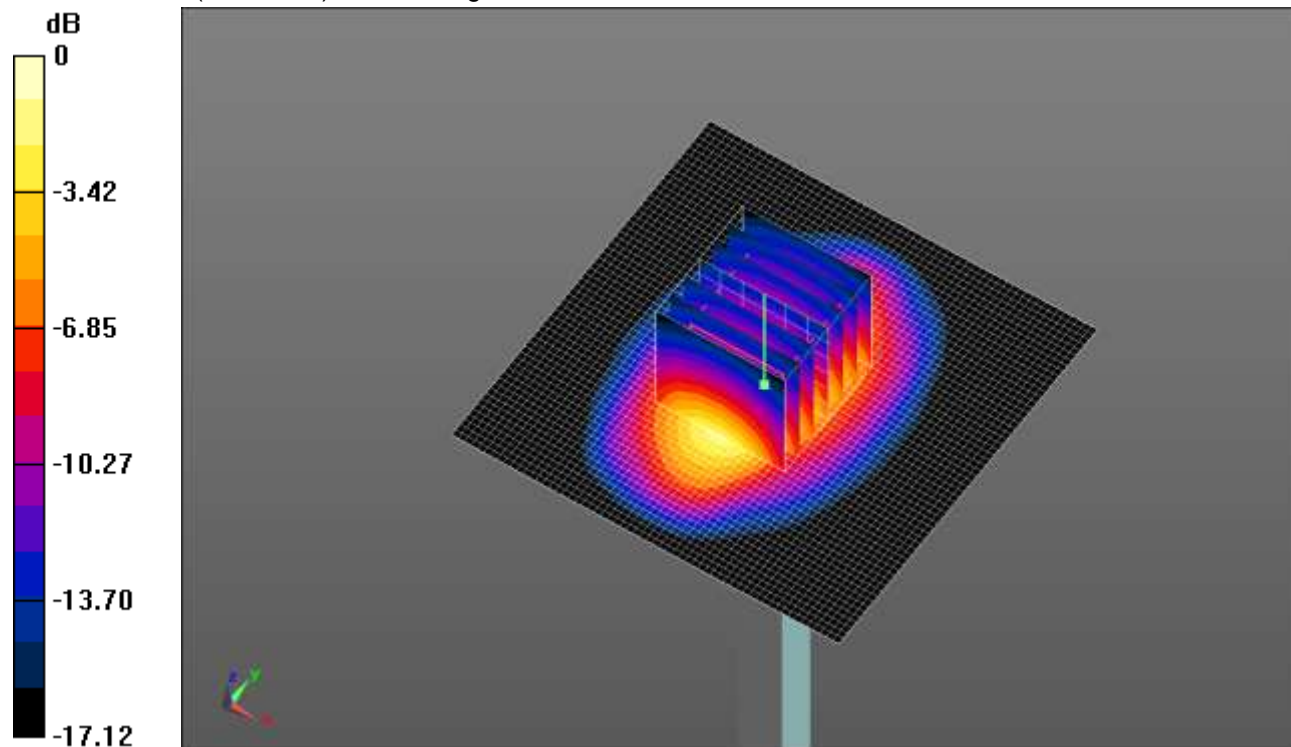

0 dB = 5.61 W/kg = 7.49 dBW/kg

20130305 SystemPerformanceCheck-D1900V2 SN 5d043

Frequency: 1900 MHz; Duty Cycle: 1:1

Body/Pin=100 mW/Z Scan (1x1x21): Measurement grid: dx=20mm, dy=20mm, dz=5mm
Maximum value of SAR (measured) = 5.53 W/kg

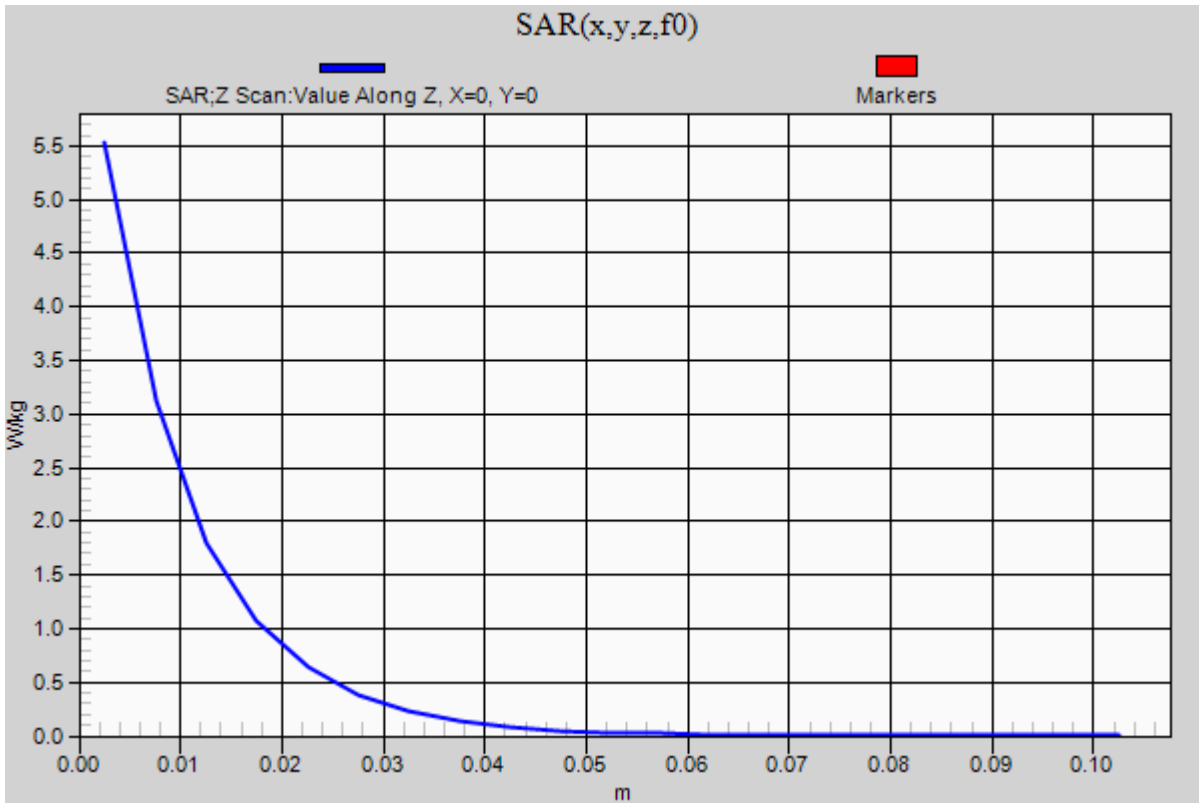

20130306_SystemPerformanceCheck-D2450V2 SN 706

Frequency: 2450 MHz; Duty Cycle: 1:1; Room Ambient Temperature: 24.0°C; Liquid Temperature: 23.0°C
 Medium parameters used: $f = 2450$ MHz; $\sigma = 1.815$ mho/m; $\epsilon_r = 38.286$; $\rho = 1000$ kg/m³

DASY5 Configuration:

- Area Scan Setting: Find Secondary Maximum Within: 2.0 dB and with a peak SAR value greater than 0.0012W/kg
- Averaged Fast SAR: Polynomial fit
- Electronics: DAE4 Sn1352; Calibrated: 10/8/2012
- Probe: EX3DV4 - SN3885; ConvF(6.97, 6.97, 6.97); Calibrated: 10/9/2012;
- Sensor-Surface: 2.5mm (Mechanical Surface Detection)
- Phantom: ELI v5.0 (B); Type: QDOVA001BB; Serial: 1185

Body/Pin=100 mW/Area Scan (71x71x1): Interpolated grid: dx=1.200 mm, dy=1.200 mm

Reference Value = 65.235 V/m; Power Drift = 0.01 dB

Fast SAR: SAR(1 g) = 5.5 W/kg; SAR(10 g) = 2.43 W/kg

Maximum value of SAR (interpolated) = 7.99 W/kg

Body/Pin=100 mW/Zoom Scan (7x7x7)/Cube 0: Measurement grid: dx=5mm, dy=5mm, dz=5mm

Reference Value = 65.235 V/m; Power Drift = 0.01 dB

Peak SAR (extrapolated) = 11.6 W/kg

SAR(1 g) = 5.45 W/kg; SAR(10 g) = 2.49 W/kg

Maximum value of SAR (measured) = 7.82 W/kg

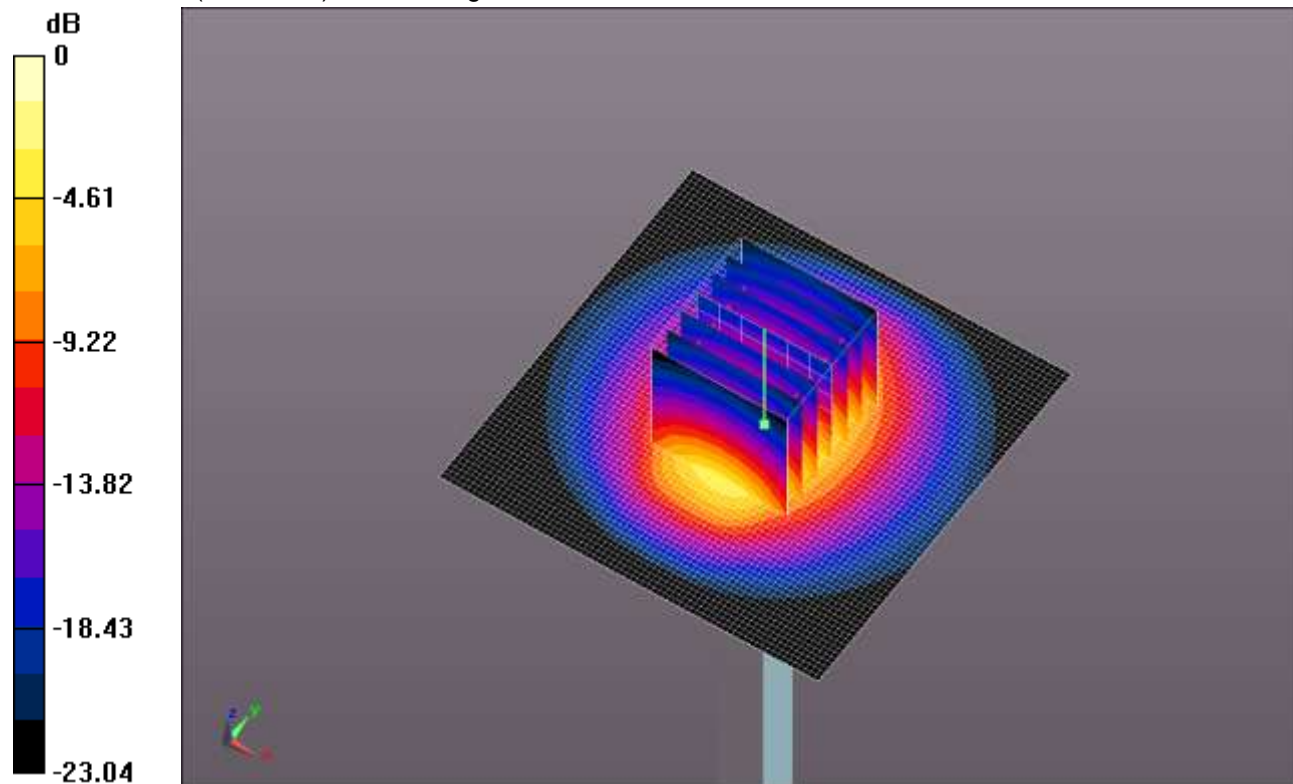

0 dB = 7.82 W/kg = 8.93 dBW/kg

20130306_SystemPerformanceCheck-D2450V2 SN 706

Frequency: 2450 MHz; Duty Cycle: 1:1

Body/Pin=100 mW/Z Scan (1x1x21): Measurement grid: dx=20mm, dy=20mm, dz=5mm
Maximum value of SAR (measured) = 7.61 W/kg

