



**FCC CFR47 PART 27 SUBPART M**

**CERTIFICATION TEST REPORT  
CLASS II PERMISSIVE CHANGE**

**FOR**

**TD-CDMA PCIE MINI MODULE WITH PANASONIC PC CF-19**

**MODEL NUMBER: WW11A**

**FCC ID: ACJ9TGWW11A**

**REPORT NUMBER: 11J14156-1, REVISION A**

**ISSUE DATE: JANUARY 18, 2012**

*Prepared for*  
**PANASONIC CORPORATION OF NORTH AMERICA  
ONE PANASONIC WAY, 4B-8, GUNPOSI  
SECAUCUS, NJ 07094, U.S.A.**

*Prepared by*  
**COMPLIANCE CERTIFICATION SERVICES (UL CCS)  
47173 BENICIA STREET  
FREMONT, CA 94538, U.S.A.  
TEL: (510) 771-1000  
FAX: (510) 661-0888**



**NVLAP LAB CODE 200065-0**

Revision History

<u>Rev.</u>	<u>Issue Date</u>	<u>Revisions</u>	<u>Revised By</u>
---	12/28/2011	Initial issue	T. Chan
	01/18/2012	Below 1GHz data and equipment information added	M. Mekuria



# 1. ATTESTATION OF TEST RESULTS

**COMPANY NAME:** PANASONIC CORPORATION OF NORTH AMERICA  
ONE PANASONIC WAY, 4B-8, GUNPOSI  
SECAUCUS, NJ 07094, U.S.A.

**EUT DESCRIPTION:** TD-CDMA PCIE MINI MODULE WITH PANASONIC PC CF-19

**MODEL:** WW11A

**SERIAL NUMBER:** 1EKSA00605

**DATE TESTED:** NOVEMBER 22 - 23, 2011 and JANUARY 18, 2012

APPLICABLE STANDARDS	
STANDARD	TEST RESULTS
FCC PART 27 SUBPART M	PASS

Compliance Certification Services (UL CCS) tested the above equipment in accordance with the requirements set forth in the above standards. All indications of Pass/Fail in this report are opinions expressed by UL CCS based on interpretations and/or observations of test results. Measurement Uncertainties were not taken into account and are published for informational purposes only. The test results show that the equipment tested is capable of demonstrating compliance with the requirements as documented in this report.

**Note:** The results documented in this report apply only to the tested sample, under the conditions and modes of operation as described herein. This document may not be altered or revised in any way unless done so by UL CCS and all revisions are duly noted in the revisions section. Any alteration of this document not carried out by UL CCS will constitute fraud and shall nullify the document. This report must not be used by the client to claim product certification, approval, or endorsement by NVLAP, NIST, any agency of the Federal Government, or any agency of any government.

Approved & Released For UL CCS By:

Tested By:

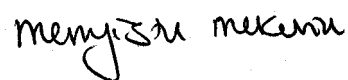

THU CHAN  
ENGINEERING MANAGER  
UL CCS

MENGISTU MEKURIA  
EMC ENGINEER  
UL CCS

## 2. TEST METHODOLOGY

The tests documented in this report were performed in accordance with TIA/EIA 603C (2004), FCC CFR 47 Part 2, and FCC CFR 47 Part 27M.

## 3. FACILITIES AND ACCREDITATION

The test sites and measurement facilities used to collect data are located at 47173 Benicia Street, Fremont, California, USA.

UL CCS is accredited by NVLAP, Laboratory Code 200065-0. The full scope of accreditation can be viewed at <http://www.ccsemc.com>.

## 4. CALIBRATION AND UNCERTAINTY

### 4.1. MEASURING INSTRUMENT CALIBRATION

The measuring equipment utilized to perform the tests documented in this report has been calibrated in accordance with the manufacturer's recommendations, and is traceable to recognized national standards.

### 4.2. SAMPLE CALCULATION

Where relevant, the following sample calculation is provided:

$$\begin{aligned} \text{Field Strength (dBuV/m)} &= \text{Measured Voltage (dBuV)} + \text{Antenna Factor (dB/m)} + \\ &\text{Cable Loss (dB)} - \text{Preamp Gain (dB)} \\ 36.5 \text{ dBuV} + 18.7 \text{ dB/m} + 0.6 \text{ dB} - 26.9 \text{ dB} &= 28.9 \text{ dBuV/m} \end{aligned}$$

### 4.3. MEASUREMENT UNCERTAINTY

Where relevant, the following measurement uncertainty levels have been estimated for tests performed on the apparatus:

PARAMETER	UNCERTAINTY
Conducted Disturbance, 0.15 to 30 MHz	3.52 dB
Radiated Disturbance, 30 to 1000 MHz	4.94 dB

Uncertainty figures are valid to a confidence level of 95%.

## 5. EQUIPMENT UNDER TEST

### 5.1. DESCRIPTION OF EUT

The EUT is a TD-CDMA PCIE Mini module embedded inside Panasonic PC CF-19.

The TD-CDMA PCIE Mini module is manufactured by IPWireless.

### 5.2. MAXIMUM OUTPUT POWER

The transmitter has a maximum conducted output power as follows:

Band	Mode	Frequency Range (MHz)	Conducted Output power (dBm)	Conducted Output power (mW)
5MHz	QPSK	2498.8 - 2687.2	24.41	276.06
	16QAM		24.22	264.24
	64QAM		24.19	262.42
10MHz	QPSK	2501.4 - 2684.6	24.56	285.76
	16QAM		24.64	291.07
	64QAM		24.42	276.69

### 5.3. DESCRIPTION OF AVAILABLE ANTENNAS

The radio utilizes an integrated PCB antenna, with a maximum peak gain of 8.0dBi.

### 5.4. DESCRIPTION OF CLASS II PERMISSIVE CHANGE

The major change filed under this application is a change on the enclose tablet PC.

### 5.5. SOFTWARE AND FIRMWARE

The test utility software used during testing was ipwpcon.exe, Ver.1c.

### 5.6. WORST-CASE CONFIGURATION AND MODE

The worst-case channel is determined as the channel with the highest output power.

To determine the worst-case, the EUT was investigated for X, Y, Z, and Mobile Positions, and the worst position among them with AC Adapter. After the investigation the worst case is turned out to be Mobile position with AC Adapter for both 5MHZ and 10MHZ Bands.

## 5.7. DESCRIPTION OF TEST SETUP

### SUPPORT EQUIPMENT

PERIPHERAL SUPPORT EQUIPMENT LIST				
Description	Manufacturer	Model	Serial Number	FCC ID
AC Adapter	Panasonic	CF-AA6373A M1	6503AM311400204A	DoC

### I/O CABLES

I/O CABLE LIST						
Cable No.	Port	# of Identical Ports	Connector Type	Cable Type	Cable Length	Remarks
1	AC	1	US 115V	Un-shielded	1.5m	N/A
2	DC	1	DC	Un-shielded	2.0m	N/A

### TEST SETUP

The EUT is a standalone device. Test software exercised the radio card.

**SETUP DIAGRAM FOR TESTS**

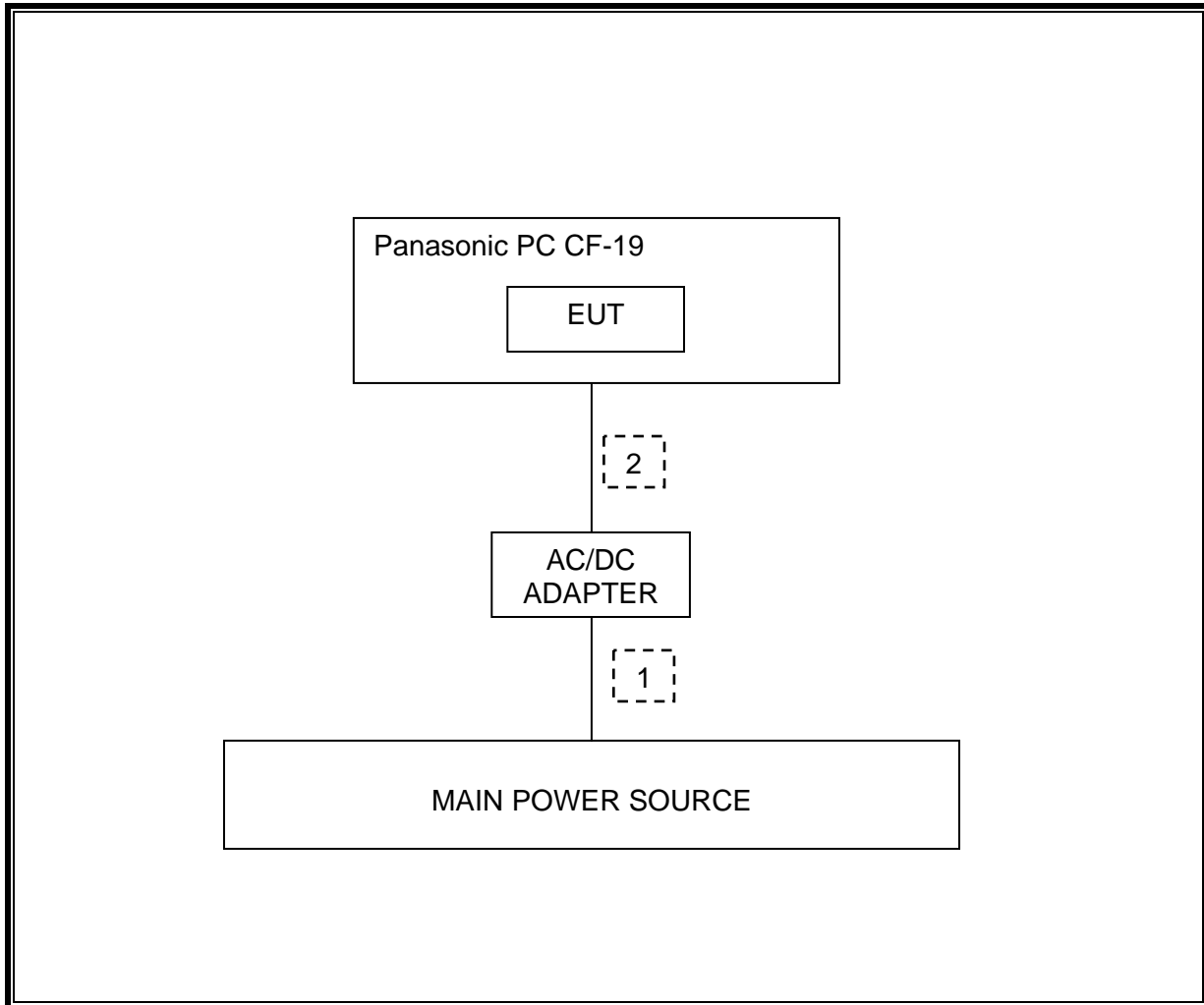

## 6. TEST AND MEASUREMENT EQUIPMENT

The following test and measurement equipment was utilized for the tests documented in this report:

TEST EQUIPMENT LIST				
Description	Manufacturer	Model	Asset	Cal Due
Spectrum Analyzer, 44 GHz	Agilent / HP	E4446A	C01069	04/07/12
Spectrum Analyzer, 44 GHz	Agilent / HP	E4446A	C01012	09/02/12
Preamplifier, 26.5 GHz	Agilent / HP	8449B	C01063	07/12/12
Preamplifier, 26.5 GHz	Agilent / HP	8449B	C01052	07/12/12
Preamplifier, 1300 MHz	Agilent / HP	8447D	C00558	01/27/12
Antenna, Horn, 18 GHz	EMCO	3115	C00783	06/29/12
Antenna, Horn, 18 GHz	EMCO	3115	C00945	10/06/12
Antenna, Bilog, 2 GHz	Sundt Sciences	JB1	C01171	07/16/12
Highpass Filter, 4.0 GHz	Micro-Tronics	HPM13351	N02706	CNR
Vector Signal Generator	Agilent / HP	E4438C	None	06/09/12

## 7. LIMITS AND RESULTS

### 7.1. RF POWER OUTPUT AT THE ANTENNA PORT

#### LIMITS

§2.1046 & §27.50 (h)(2) Mobile and other user stations. Mobile stations are limited to 2.0 watts EIRP. All user stations are limited to 2.0 watts transmitter output power.

#### TEST PROCEDURE

ANSI / TIA / EIA 603 Clause 2.2.17 and §27.50 (i) and KDB 971168

#### RESULTS

Note: the conducted output power is within +/- 0.5 dBm margin of the original power measurements.

## **7.2. RADIATED TEST RESULTS**

### **7.2.1. FIELD STRENGTH OF SPURIOUS RADIATION**

#### **LIMIT**

§2.1053

§27.53 (m)(4) For mobile digital stations, the attenuation factor shall be not less than  $43 + 10 \log (P)$  dB at the channel edge and  $55 + 10 \log (P)$  dB at 5.5 megahertz from the channel edges.

#### **TEST PROCEDURE**

ANSI / TIA / EIA 603 Clause 3.2.12 & FCC 27

#### **RESULTS**

**Below 1GHz (Worst Case)**

**Compliance Certification Services**  
**30 - 1000MHz Substitution Measurement**

**Company:** PANASONIC ELECTRONICS  
**Project #:** 11U14156  
**Date:** 1/18/2011  
**Test Engineer:** MENGISTU MEKURIA  
**Configuration:** EUT WITH AC ACAPTER  
**Mode:** TX, WORST-CASE

Chamber

3m Chamber

Pre-amplifier

T15 8447D

Filter

Limit

PART 27

f MHz	SA reading (dBm)	Ant. Pol. (H/V)	Distance (m)	Path Loss (dB)	Preamp (dB)	Filter (dB)	ERP (dBm)	Limit (dBm)	Delta (dB)	Notes
747.80	-67.2	H	3.0	28.3	28.4		-67.3	-25.0	-42.3	
865.80	-61.9	H	3.0	29.7	28.0		-60.2	-25.0	-35.2	
915.90	-63.3	H	3.0	30.4	27.9		-60.8	-25.0	-35.8	
940.20	-65.7	H	3.0	31.0	27.8		-62.4	-25.0	-37.4	
616.80	-64.3	V	3.0	28.5	28.6		-64.4	-25.0	-39.4	
776.90	-63.5	V	3.0	32.2	28.3		-59.5	-25.0	-34.5	
809.20	-66.3	V	3.0	32.9	28.2		-61.6	-25.0	-36.6	
864.20	-60.0	V	3.0	32.4	28.0		-55.6	-25.0	-30.6	
		V								
		V								

Rev. 03.03.09

5MHz\_QPSK

Compliance Certification Services  
 Above 1GHz High Frequency Substitution Measurement

Company: PANASONIC  
 Project #: 11J14156  
 Date: 11/22/2011  
 Test Engineer: MENGISTU MEKURIA  
 Configuration: EUT only  
 Mode: TX, QPSK\_5MHz BAND

<b>Chamber</b>	<b>Pre-amplifier</b>	<b>Filter</b>	<b>Limit</b>
5m Chamber B	T145 8449B	Filter 1	Part 27

f GHz	SG reading (dBm)	Ant. Pol. (H/V)	Distance (m)	Preamp (dB)	Filter (dB)	EIRP (dBm)	Limit (dBm)	Delta (dB)	Notes
<b>Low Ch (2498.8MHz)</b>									
4.998	-0.5	V	3.0	35.3	1.0	-34.8	-25.0	-9.8	
7.496	-8.3	V	3.0	35.7	1.0	-43.0	-25.0	-18.0	
9.995	-13.5	V	3.0	35.5	1.0	-48.1	-25.0	-23.1	
12.494	-12.6	V	3.0	34.1	1.0	-45.7	-25.0	-20.7	
4.998	-2.0	H	3.0	35.3	1.0	-36.3	-25.0	-11.3	
7.496	-3.7	H	3.0	35.7	1.0	-38.4	-25.0	-13.4	
9.995	-11.3	H	3.0	35.5	1.0	-45.9	-25.0	-20.9	
<b>Mid Ch (2593MHz)</b>									
5.186	-12.1	V	3.0	35.3	1.0	-46.4	-25.0	-21.4	
7.779	-11.0	V	3.0	35.7	1.0	-45.7	-25.0	-20.7	
10.372	-12.8	V	3.0	35.3	1.0	-47.0	-25.0	-22.0	
5.186	-11.8	H	3.0	35.3	1.0	-46.2	-25.0	-21.2	
7.779	-8.6	H	3.0	35.7	1.0	-43.3	-25.0	-18.3	
10.372	-12.5	H	3.0	35.3	1.0	-46.8	-25.0	-21.8	
12.965		H	3.0	34.0	1.0	-33.0	-25.0	-8.0	
<b>High Ch (2685MHz)</b>									
5.374	-10.4	V	3.0	35.4	1.0	-44.7	-25.0	-19.7	
8.062	-8.5	V	3.0	35.7	1.0	-43.1	-25.0	-18.1	
10.749	-13.3	V	3.0	35.0	1.0	-47.4	-25.0	-22.4	
5.374	-14.3	H	3.0	35.4	1.0	-48.7	-25.0	-23.7	
8.062	-5.4	H	3.0	35.7	1.0	-40.0	-25.0	-15.0	
10.749	-12.3	H	3.0	35.0	1.0	-46.3	-25.0	-21.3	

Rev. 03.03.09

Note: No other emissions were detected above the system noise floor.

5MHz\_16QAM

Compliance Certification Services  
 Above 1GHz High Frequency Substitution Measurement

Company: PANASONIC  
 Project #: 11J14156  
 Date: 11/22/2011  
 Test Engineer: MENGISTU MEKURIA  
 Configuration: EUT only  
 Mode: TX, 16QAM\_5MHz BAND

<b>Chamber</b>	<b>Pre-amplifier</b>	<b>Filter</b>	<b>Limit</b>
5m Chamber B	T145 8449B	Filter 1	Part 27

f GHz	SG reading (dBm)	Ant. Pol. (H/V)	Distance (m)	Preamp (dB)	Filter (dB)	EIRP (dBm)	Limit (dBm)	Delta (dB)	Notes
<b>Low Ch (2498.8MHz)</b>									
4.998	0.3	V	3.0	35.3	1.0	-34.0	-25.0	-9.0	
7.496	-7.6	V	3.0	35.7	1.0	-42.3	-25.0	-17.3	
9.995	-13.1	V	3.0	35.5	1.0	-47.6	-25.0	-22.6	
4.998	-3.5	H	3.0	35.3	1.0	-37.8	-25.0	-12.8	
7.496	-4.0	H	3.0	35.7	1.0	-38.7	-25.0	-13.7	
9.995	-11.3	H	3.0	35.5	1.0	-45.9	-25.0	-20.9	
<b>Mid Ch (2593MHz)</b>									
5.186	-11.2	V	3.0	35.3	1.0	-45.5	-25.0	-20.5	
7.779	-12.2	V	3.0	35.7	1.0	-46.9	-25.0	-21.9	
10.372	-14.1	V	3.0	35.3	1.0	-48.3	-25.0	-23.3	
5.186	-12.5	H	3.0	35.3	1.0	-46.8	-25.0	-21.8	
7.779	-8.1	H	3.0	35.7	1.0	-42.8	-25.0	-17.8	
10.372	-12.2	H	3.0	35.3	1.0	-46.5	-25.0	-21.5	
<b>High Ch (2685MHz)</b>									
5.374	-12.6	V	3.0	35.4	1.0	-46.9	-25.0	-21.9	
8.062	-9.0	V	3.0	35.7	1.0	-43.6	-25.0	-18.6	
10.749	-13.4	V	3.0	35.0	1.0	-47.5	-25.0	-22.5	
13.436	-10.3	V	3.0	33.9	1.0	-43.2	-25.0	-18.2	
5.374	-14.0	H	3.0	35.4	1.0	-48.4	-25.0	-23.4	
8.062	-5.6	H	3.0	35.7	1.0	-40.3	-25.0	-15.3	
10.749	-13.6	H	3.0	35.0	1.0	-47.6	-25.0	-22.6	
13.436	-10.7	H	3.0	33.9	1.0	-43.6	-25.0	-18.6	

Rev. 03.03.09

Note: No other emissions were detected above the system noise floor.

5MHz\_64QAM

Compliance Certification Services  
 Above 1GHz High Frequency Substitution Measurement

Company: PANASONIC  
 Project #: 11J14156  
 Date: 11/22/2011  
 Test Engineer: MENGISTU MEKURIA  
 Configuration: EUT only  
 Mode: TX, 64QAM\_5MHz BAND

<b>Chamber</b>	<b>Pre-amplifier</b>	<b>Filter</b>	<b>Limit</b>
5m Chamber B	T145 8449B	Filter 1	Part 27

f GHz	SG reading (dBm)	Ant. Pol. (H/V)	Distance (m)	Preamp (dB)	Filter (dB)	EIRP (dBm)	Limit (dBm)	Delta (dB)	Notes
<b>Low Ch (2498.8MHz)</b>									
4.998	0.1	V	3.0	35.3	1.0	-34.2	-25.0	-9.2	
7.496	-7.1	V	3.0	35.7	1.0	-41.8	-25.0	-16.8	
9.995	-12.8	V	3.0	35.5	1.0	-47.3	-25.0	-22.3	
4.998	-2.8	H	3.0	35.3	1.0	-37.2	-25.0	-12.2	
7.496	-4.6	H	3.0	35.7	1.0	-39.3	-25.0	-14.3	
9.995	-10.0	H	3.0	35.5	1.0	-44.5	-25.0	-19.5	
<b>Mid Ch (2593MHz)</b>									
5.186	-11.0	V	3.0	35.3	1.0	-45.4	-25.0	-20.4	
7.779	-10.6	V	3.0	35.7	1.0	-45.3	-25.0	-20.3	
10.372	-12.3	V	3.0	35.3	1.0	-46.5	-25.0	-21.5	
5.186	-12.7	H	3.0	35.3	1.0	-47.1	-25.0	-22.1	
7.779	-8.3	H	3.0	35.7	1.0	-43.0	-25.0	-18.0	
10.372	-12.2	H	3.0	35.3	1.0	-46.5	-25.0	-21.5	
<b>High Ch (2685MHz)</b>									
5.374	-12.3	V	3.0	35.4	1.0	-46.6	-25.0	-21.6	
8.062	-10.4	V	3.0	35.7	1.0	-45.1	-25.0	-20.1	
10.749	-13.6	V	3.0	35.0	1.0	-47.6	-25.0	-22.6	
13.436	-11.9	V	3.0	33.9	1.0	-44.8	-25.0	-19.8	
5.374	-14.4	H	3.0	35.4	1.0	-48.8	-25.0	-23.8	
8.062	-4.8	H	3.0	35.7	1.0	-39.4	-25.0	-14.4	
10.749	-12.9	H	3.0	35.0	1.0	-46.9	-25.0	-21.9	
13.436	-10.9	H	3.0	33.9	1.0	-43.9	-25.0	-18.9	

Rev. 03.03.09

Note: No other emissions were detected above the system noise floor.

10MHz\_QPSK

Compliance Certification Services  
 Above 1GHz High Frequency Substitution Measurement

Company: PANASONIC  
 Project #: 11J14156  
 Date: 11/22/2011  
 Test Engineer: MENGISTU MEKURIA  
 Configuration: EUT only  
 Mode: TX, QPSK\_10MHz BAND

<b>Chamber</b>	<b>Pre-amplifier</b>	<b>Filter</b>	<b>Limit</b>
5m Chamber B	T145 8449B	Filter 1	Part 27

f GHz	SG reading (dBm)	Ant. Pol. (H/V)	Distance (m)	Preamp (dB)	Filter (dB)	EIRP (dBm)	Limit (dBm)	Delta (dB)	Notes
<b>Low Ch (2501.4MHz)</b>									
5.003	-1.9	V	3.0	35.3	1.0	-36.2	-25.0	-11.2	
7.504	-10.3	V	3.0	35.7	1.0	-45.0	-25.0	-20.0	
10.006	-13.7	V	3.0	35.5	1.0	-48.2	-25.0	-23.2	
12.507	-11.9	V	3.0	34.1	1.0	-45.0	-25.0	-20.0	
5.003	-11.9	H	3.0	35.3	1.0	-46.2	-25.0	-21.2	
7.504	-4.5	H	3.0	35.7	1.0	-39.2	-25.0	-14.2	
10.006	-10.5	H	3.0	35.5	1.0	-45.0	-25.0	-20.0	
12.507	-12.8	H	3.0	34.1	1.0	-45.9	-25.0	-20.9	
<b>Mid Ch (2593MHz)</b>									
5.186	-11.0	V	3.0	35.3	1.0	-45.3	-25.0	-20.3	
7.779	-14.5	V	3.0	35.7	1.0	-49.2	-25.0	-24.2	
10.372	-12.6	V	3.0	35.3	1.0	-46.8	-25.0	-21.8	
12.965	-11.1	V	3.0	34.0	1.0	-44.1	-25.0	-19.1	
5.186	-14.3	H	3.0	35.3	1.0	-48.7	-25.0	-23.7	
7.779	-8.4	H	3.0	35.7	1.0	-43.0	-25.0	-18.0	
10.372	-10.7	H	3.0	35.3	1.0	-45.0	-25.0	-20.0	
12.965	-11.7	H	3.0	34.0	1.0	-44.7	-25.0	-19.7	
<b>High Ch (2684.6MHz)</b>									
5.369	-10.8	V	3.0	35.4	1.0	-45.2	-25.0	-20.2	
8.054	-14.0	V	3.0	35.7	1.0	-48.6	-25.0	-23.6	
10.738	-12.9	V	3.0	35.0	1.0	-46.9	-25.0	-21.9	
13.423	-12.0	V	3.0	33.9	1.0	-44.9	-25.0	-19.9	
5.369	-14.6	H	3.0	35.4	1.0	-49.0	-25.0	-24.0	
8.054	-12.5	H	3.0	35.7	1.0	-47.2	-25.0	-22.2	
10.738	-11.4	H	3.0	35.0	1.0	-45.4	-25.0	-20.4	
13.423	-10.2	H	3.0	33.9	1.0	-43.1	-25.0	-18.1	

Rev. 03.03.09

Note: No other emissions were detected above the system noise floor.

10MHz\_16QAM

Compliance Certification Services  
 Above 1GHz High Frequency Substitution Measurement

Company: PANASONIC  
 Project #: 11J14156  
 Date: 11/22/2011  
 Test Engineer: MENGISTU MEKURIA  
 Configuration: EUT only  
 Mode: TX, 16QAM\_10MHz BAND

<b>Chamber</b>	<b>Pre-amplifier</b>	<b>Filter</b>	<b>Limit</b>
5m Chamber B	T145 8449B	Filter 1	Part 27

f GHz	SG reading (dBm)	Ant. Pol. (H/V)	Distance (m)	Preamp (dB)	Filter (dB)	EIRP (dBm)	Limit (dBm)	Delta (dB)	Notes
Low Ch (2501.4MHz)									
5.003	-3.6	V	3.0	35.3	1.0	-37.9	-25.0	-12.9	
7.504	-8.6	V	3.0	35.7	1.0	-43.3	-25.0	-18.3	
10.006	-12.4	V	3.0	35.5	1.0	-46.9	-25.0	-21.9	
12.507	-11.9	V	3.0	34.1	1.0	-45.0	-25.0	-20.0	
5.003	-12.2	H	3.0	35.3	1.0	-46.5	-25.0	-21.5	
7.504	-5.6	H	3.0	35.7	1.0	-40.3	-25.0	-15.3	
10.006	-11.2	H	3.0	35.5	1.0	-45.7	-25.0	-20.7	
12.507	-12.3	H	3.0	34.1	1.0	-45.5	-25.0	-20.5	
Mid Ch (2593MHz)									
5.186	-13.1	V	3.0	35.3	1.0	-47.4	-25.0	-22.4	
7.779	-12.5	V	3.0	35.7	1.0	-47.2	-25.0	-22.2	
10.372	-13.8	V	3.0	35.3	1.0	-48.1	-25.0	-23.1	
12.965	-13.2	V	3.0	34.0	1.0	-46.2	-25.0	-21.2	
5.186	-14.5	H	3.0	35.3	1.0	-48.8	-25.0	-23.8	
7.779	-9.9	H	3.0	35.7	1.0	-44.6	-25.0	-19.6	
10.372	-11.6	H	3.0	35.3	1.0	-45.9	-25.0	-20.9	
12.965	-11.7	H	3.0	34.0	1.0	-44.7	-25.0	-19.7	
High Ch (2684.6MHz)									
5.369	-12.5	V	3.0	35.4	1.0	-46.9	-25.0	-21.9	
8.054	-12.0	V	3.0	35.7	1.0	-46.7	-25.0	-21.7	
10.738	-14.8	V	3.0	35.0	1.0	-48.8	-25.0	-23.8	
13.423	-10.9	V	3.0	33.9	1.0	-43.8	-25.0	-18.8	
5.369	-15.5	H	3.0	35.4	1.0	-49.9	-25.0	-24.9	
8.054	-5.5	H	3.0	35.7	1.0	-40.2	-25.0	-15.2	
10.738	-9.4	H	3.0	35.0	1.0	-43.5	-25.0	-18.5	
13.423	-11.0	H	3.0	33.9	1.0	-43.9	-25.0	-18.9	

Rev. 03.03.09

Note: No other emissions were detected above the system noise floor.

10MHz\_64QAM

Compliance Certification Services  
 Above 1GHz High Frequency Substitution Measurement

Company: PANASONIC  
 Project #: 11J14156  
 Date: 11/22/2011  
 Test Engineer: MENGISTU MEKURIA  
 Configuration: EUT only  
 Mode: TX, 64QAM\_10MHz BAND

<b>Chamber</b>	<b>Pre-amplifier</b>	<b>Filter</b>	<b>Limit</b>
5m Chamber B	T145 8449B	Filter 1	Part 27

f GHz	SG reading (dBm)	Ant. Pol. (H/V)	Distance (m)	Preamp (dB)	Filter (dB)	EIRP (dBm)	Limit (dBm)	Delta (dB)	Notes
<b>Low Ch (2501.4MHz)</b>									
5.003	-2.7	V	3.0	35.3	1.0	-37.1	-25.0	-12.1	
7.504	-0.6	V	3.0	35.7	1.0	-35.3	-25.0	-10.3	
10.006	-12.8	V	3.0	35.5	1.0	-47.3	-25.0	-22.3	
12.507	-11.9	V	3.0	34.1	1.0	-45.0	-25.0	-20.0	
5.003	-10.3	H	3.0	35.3	1.0	-44.6	-25.0	-19.6	
7.504	-0.3	H	3.0	35.7	1.0	-35.0	-25.0	-10.0	
10.006	-11.7	H	3.0	35.5	1.0	-46.2	-25.0	-21.2	
12.507	-12.9	H	3.0	34.1	1.0	-46.0	-25.0	-21.0	
<b>Mid Ch (2593MHz)</b>									
5.186	-12.8	V	3.0	35.3	1.0	-47.1	-25.0	-22.1	
7.779	-8.7	V	3.0	35.7	1.0	-43.4	-25.0	-18.4	
10.372	-13.9	V	3.0	35.3	1.0	-48.2	-25.0	-23.2	
12.965	-10.2	V	3.0	34.0	1.0	-43.2	-25.0	-18.2	
5.186	-13.3	H	3.0	35.3	1.0	-47.6	-25.0	-22.6	
7.779	-4.1	H	3.0	35.7	1.0	-38.7	-25.0	-13.7	
10.372	-12.2	H	3.0	35.3	1.0	-46.5	-25.0	-21.5	
12.965	-10.0	H	3.0	34.0	1.0	-43.0	-25.0	-18.0	
<b>High Ch (2684.6MHz)</b>									
5.369	-11.1	V	3.0	35.4	1.0	-45.5	-25.0	-20.5	
8.054	-8.1	V	3.0	35.7	1.0	-42.8	-25.0	-17.8	
10.738	-14.6	V	3.0	35.0	1.0	-48.7	-25.0	-23.7	
13.423	-8.7	V	3.0	33.9	1.0	-41.7	-25.0	-16.7	
5.369	-13.4	H	3.0	35.4	1.0	-47.8	-25.0	-22.8	
8.054	-4.7	H	3.0	35.7	1.0	-39.3	-25.0	-14.3	
10.738	-11.7	H	3.0	35.0	1.0	-45.7	-25.0	-20.7	
13.423	-10.4	H	3.0	33.9	1.0	-43.3	-25.0	-18.3	

Rev. 03.03.09

Note: No other emissions were detected above the system noise floor.