

Table of Contents

Release Control Record	3
1. Summary of Maximum SAR Value	4
2. Description of Equipment Under Test	5
3. SAR Measurement System	6
3.1 Definition of Specific Absorption Rate (SAR)	6
3.2 SPEAG DASY System	6
3.2.1 Robot.....	7
3.2.2 Probes.....	8
3.2.3 Data Acquisition Electronics (DAE)	8
3.2.4 Phantoms	9
3.2.5 Device Holder.....	10
3.2.6 System Validation Dipoles.....	10
3.2.7 Tissue Simulating Liquids.....	11
3.3 SAR System Verification	14
3.4 SAR Measurement Procedure	15
3.4.1 Area & Zoom Scan Procedure	15
3.4.2 Volume Scan Procedure.....	15
3.4.3 Power Drift Monitoring.....	16
3.4.4 Spatial Peak SAR Evaluation	16
3.4.5 SAR Averaged Methods	16
4. SAR Measurement Evaluation	17
4.1 EUT Configuration and Setting.....	17
4.2 EUT Testing Position	19
4.2.1 SAR Test Exclusion Evaluations	19
4.2.2 Simultaneous Transmission Possibilities.....	21
4.3 Tissue Verification	22
4.4 System Validation.....	22
4.5 System Verification.....	23
4.6 Maximum Output Power.....	24
4.6.1 Maximum Conducted Power	24
4.6.2 Measured Conducted Power Result.....	25
4.7 SAR Testing Results	26
4.7.1 SAR Test Reduction Considerations	26
4.7.2 SAR Results for Body Exposure Condition (Separation Distance is 0 cm Gap)	27
4.7.3 SAR Measurement Variability.....	29
4.7.4 Simultaneous Multi-band Transmission Evaluation	30
5. Calibration of Test Equipment.....	55
6. Measurement Uncertainty.....	56
7. Information on the Testing Laboratories.....	58
Appendix A. SAR Plots of System Verification	
Appendix B. SAR Plots of SAR Measurement	
Appendix C. Calibration Certificate for Probe and Dipole	
Appendix D. Photographs of EUT and Setup	

1. Summary of Maximum SAR Value

Equipment Class	Mode	Highest Reported Body SAR _{1g} (0 cm Gap) (W/kg)
PCB	WCDMA II	1.378
	WCDMA IV	1.389
	WCDMA V	1.067
	CDMA BC0	1.234
	CDMA BC1	1.399
	CDMA BC10	1.098
	LTE 2	1.397
	LTE 4	1.375
	LTE 5	1.081
	LTE 13	1.245
	LTE 17	0.896
LTE 25	1.316	
DTS	2.4G WLAN	0.56
NII	5.3G WLAN	0.85
	5.6G WLAN	1.16
	5.8G WLAN	1.10
DSS	Bluetooth	0.01
Highest Simultaneous Transmission SAR		Body (W/kg)
PCB + DTS + DSS		1.588
PCB + NII + DSS		1.585

Note:

1. The SAR limit (**Head & Body: SAR_{1g} 1.6 W/kg, Extremity: SAR_{10g} 4.0 W/kg**) for general population / uncontrolled exposure is specified in FCC 47 CFR part 2 (2.1093) and ANSI/IEEE C95.1-1992.
2. WWAN SAR is referring to UL report (Report No.: 11018665H-A-R1).

3. SAR Measurement System

3.1 Definition of Specific Absorption Rate (SAR)

SAR is related to the rate at which energy is absorbed per unit mass in an object exposed to a radio field. The SAR distribution in a biological body is complicated and is usually carried out by experimental techniques or numerical modeling. The standard recommends limits for two tiers of groups, occupational/controlled and general population/uncontrolled, based on a person's awareness and ability to exercise control over his or her exposure. In general, occupational/controlled exposure limits are higher than the limits for general population/uncontrolled.

The SAR definition is the time derivative (rate) of the incremental energy (dW) absorbed by (dissipated in) an incremental mass (dm) contained in a volume element (dv) of a given density (ρ). The equation description is as below:

$$\text{SAR} = \frac{d}{dt} \left(\frac{dW}{dm} \right) = \frac{d}{dt} \left(\frac{dW}{\rho dv} \right)$$

SAR is expressed in units of Watts per kilogram (W/kg)

SAR measurement can be related to the electrical field in the tissue by

$$\text{SAR} = \frac{\sigma |E|^2}{\rho}$$

Where: σ is the conductivity of the tissue, ρ is the mass density of the tissue and E is the RMS electrical field strength.

3.2 SPEAG DASY System

DASY system consists of high precision robot, probe alignment sensor, phantom, robot controller, controlled measurement server and near-field probe. The robot includes six axes that can move to the precision position of the DASY4/5 software defined. The DASY software can define the area that is detected by the probe. The robot is connected to controlled box. Controlled measurement server is connected to the controlled robot box. The DAE includes amplifier, signal multiplexing, AD converter, offset measurement and surface detection. It is connected to the Electro-optical coupler (ECO). The ECO performs the conversion from the optical into digital electric signal of the DAE and transfers data to the PC.

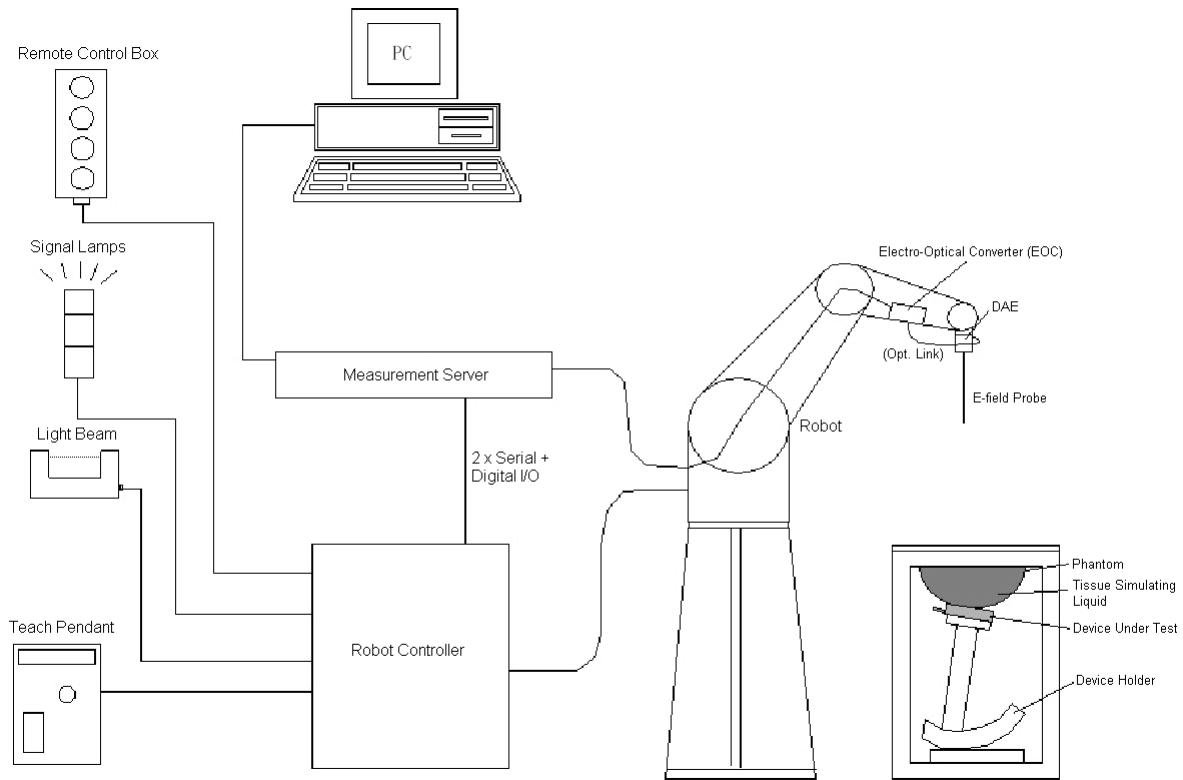

Fig-3.1 SPEAG DASY52 System Setup

3.2.1 Robot

The SPEAG DASY52 systems use the high precision robots from Stäubli SA (France). For the 6-axis controller system, the robot controller version (CS8c) from Stäubli is used. The Stäubli robot series have many features that are important for our application:

- High precision (repeatability ± 0.035 mm)
- High reliability (industrial design)
- Jerk-free straight movements
- Low ELF interference (the closed metallic construction shields against motor control fields)





Fig-3.2 SPEAG DASY52 System

FCC SAR Test Report

3.2.2 Probes

The SAR measurement is conducted with the dosimetric probe. The probe is specially designed and calibrated for use in liquid with high permittivity. The dosimetric probe has special calibration in liquid at different frequency.

Model	EX3DV4	
Construction	Symmetrical design with triangular core. Built-in shielding against static charges. PEEK enclosure material (resistant to organic solvents, e.g., DGBE).	
Frequency	10 MHz to 6 GHz Linearity: ± 0.2 dB	
Directivity	± 0.3 dB in HSL (rotation around probe axis) ± 0.5 dB in tissue material (rotation normal to probe axis)	
Dynamic Range	10 μ W/g to 100 mW/g Linearity: ± 0.2 dB (noise: typically < 1 μ W/g)	
Dimensions	Overall length: 337 mm (Tip: 20 mm) Tip diameter: 2.5 mm (Body: 12 mm) Typical distance from probe tip to dipole centers: 1 mm	

Model	ES3DV3	
Construction	Symmetrical design with triangular core. Interleaved sensors. Built-in shielding against static charges. PEEK enclosure material (resistant to organic solvents, e.g., DGBE).	
Frequency	10 MHz to 4 GHz Linearity: ± 0.2 dB	
Directivity	± 0.2 dB in HSL (rotation around probe axis) ± 0.3 dB in tissue material (rotation normal to probe axis)	
Dynamic Range	5 μ W/g to 100 mW/g Linearity: ± 0.2 dB	
Dimensions	Overall length: 337 mm (Tip: 20 mm) Tip diameter: 3.9 mm (Body: 12 mm) Distance from probe tip to dipole centers: 2.0 mm	

3.2.3 Data Acquisition Electronics (DAE)

Model	DAE3, DAE4	
Construction	Signal amplifier, multiplexer, A/D converter and control logic. Serial optical link for communication with DASY embedded system (fully remote controlled). Two step probe touch detector for mechanical surface detection and emergency robot stop.	
Measurement Range	-100 to +300 mV (16 bit resolution and two range settings: 4mV, 400mV)	
Input Offset Voltage	< 5 μ V (with auto zero)	
Input Bias Current	< 50 fA	
Dimensions	60 x 60 x 68 mm	

FCC SAR Test Report

3.2.4 Phantoms

Model	Twin SAM	
Construction	The shell corresponds to the specifications of the Specific Anthropomorphic Mannequin (SAM) phantom defined in IEEE 1528 and IEC 62209-1. It enables the dosimetric evaluation of left and right hand phone usage as well as body mounted usage at the flat phantom region. A cover prevents evaporation of the liquid. Reference markings on the phantom allow the complete setup of all predefined phantom positions and measurement grids by teaching three points with the robot.	
Material	Vinylester, glass fiber reinforced (VE-GF)	
Shell Thickness	2 ± 0.2 mm (6 ± 0.2 mm at ear point)	
Dimensions	Length: 1000 mm Width: 500 mm Height: adjustable feet	
Filling Volume	approx. 25 liters	

Model	ELI	
Construction	Phantom for compliance testing of handheld and body-mounted wireless devices in the frequency range of 30 MHz to 6 GHz. ELI is fully compatible with the IEC 62209-2 standard and all known tissue simulating liquids. ELI has been optimized regarding its performance and can be integrated into our standard phantom tables. A cover prevents evaporation of the liquid. Reference markings on the phantom allow installation of the complete setup, including all predefined phantom positions and measurement grids, by teaching three points. The phantom is compatible with all SPEAG dosimetric probes and dipoles.	
Material	Vinylester, glass fiber reinforced (VE-GF)	
Shell Thickness	2.0 ± 0.2 mm (bottom plate)	
Dimensions	Major axis: 600 mm Minor axis: 400 mm	
Filling Volume	approx. 30 liters	

FCC SAR Test Report

3.2.5 Device Holder

Model	Mounting Device	
Construction	In combination with the Twin SAM Phantom or ELI4, the Mounting Device enables the rotation of the mounted transmitter device in spherical coordinates. Rotation point is the ear opening point. Transmitter devices can be easily and accurately positioned according to IEC, IEEE, FCC or other specifications. The device holder can be locked for positioning at different phantom sections (left head, right head, flat).	
Material	POM	

Model	Laptop Extensions Kit	
Construction	Simple but effective and easy-to-use extension for Mounting Device that facilitates the testing of larger devices according to IEC 62209-2 (e.g., laptops, cameras, etc.). It is lightweight and fits easily on the upper part of the Mounting Device in place of the phone positioner.	
Material	POM, Acrylic glass, Foam	

3.2.6 System Validation Dipoles

Model	D-Serial	
Construction	Symmetrical dipole with 1/4 balun. Enables measurement of feed point impedance with NWA. Matched for use near flat phantoms filled with tissue simulating solutions.	
Frequency	750 MHz to 5800 MHz	
Return Loss	> 20 dB	
Power Capability	> 100 W (f < 1GHz), > 40 W (f > 1GHz)	

3.2.7 Tissue Simulating Liquids

For SAR measurement of the field distribution inside the phantom, the phantom must be filled with homogeneous tissue simulating liquid to a depth of at least 15 cm. For head SAR testing, the liquid height from the ear reference point (ERP) of the phantom to the liquid top surface is larger than 15 cm. For body SAR testing, the liquid height from the center of the flat phantom to the liquid top surface is larger than 15 cm. The nominal dielectric values of the tissue simulating liquids in the phantom and the tolerance of 5% are listed in Table-3.1.

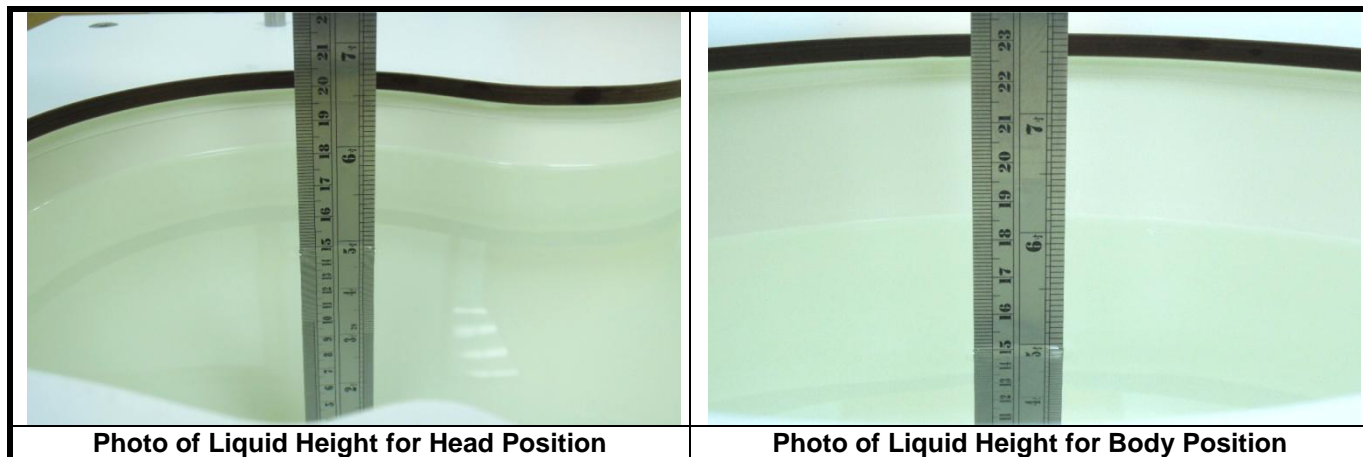

The dielectric properties of the head tissue simulating liquids are defined in IEEE 1528, and KDB 865664 D01 Appendix A. For the body tissue simulating liquids, the dielectric properties are defined in KDB 865664 D01 Appendix A. The dielectric properties of the tissue simulating liquids were verified prior to the SAR evaluation using a dielectric assessment kit and a network analyzer.

Table-3.1 Targets of Tissue Simulating Liquid

Frequency (MHz)	Target Permittivity	Range of $\pm 5\%$	Target Conductivity	Range of $\pm 5\%$
For Head				
750	41.9	39.8 ~ 44.0	0.89	0.85 ~ 0.93
835	41.5	39.4 ~ 43.6	0.90	0.86 ~ 0.95
900	41.5	39.4 ~ 43.6	0.97	0.92 ~ 1.02
1450	40.5	38.5 ~ 42.5	1.20	1.14 ~ 1.26
1640	40.3	38.3 ~ 42.3	1.29	1.23 ~ 1.35
1750	40.1	38.1 ~ 42.1	1.37	1.30 ~ 1.44
1800	40.0	38.0 ~ 42.0	1.40	1.33 ~ 1.47
1900	40.0	38.0 ~ 42.0	1.40	1.33 ~ 1.47
2000	40.0	38.0 ~ 42.0	1.40	1.33 ~ 1.47
2300	39.5	37.5 ~ 41.5	1.67	1.59 ~ 1.75
2450	39.2	37.2 ~ 41.2	1.80	1.71 ~ 1.89
2600	39.0	37.1 ~ 41.0	1.96	1.86 ~ 2.06
3500	37.9	36.0 ~ 39.8	2.91	2.76 ~ 3.06
5200	36.0	34.2 ~ 37.8	4.66	4.43 ~ 4.89
5300	35.9	34.1 ~ 37.7	4.76	4.52 ~ 5.00
5500	35.6	33.8 ~ 37.4	4.96	4.71 ~ 5.21
5600	35.5	33.7 ~ 37.3	5.07	4.82 ~ 5.32
5800	35.3	33.5 ~ 37.1	5.27	5.01 ~ 5.53
For Body				
750	55.5	52.7 ~ 58.3	0.96	0.91 ~ 1.01
835	55.2	52.4 ~ 58.0	0.97	0.92 ~ 1.02
900	55.0	52.3 ~ 57.8	1.05	1.00 ~ 1.10
1450	54.0	51.3 ~ 56.7	1.30	1.24 ~ 1.37
1640	53.8	51.1 ~ 56.5	1.40	1.33 ~ 1.47
1750	53.4	50.7 ~ 56.1	1.49	1.42 ~ 1.56
1800	53.3	50.6 ~ 56.0	1.52	1.44 ~ 1.60
1900	53.3	50.6 ~ 56.0	1.52	1.44 ~ 1.60
2000	53.3	50.6 ~ 56.0	1.52	1.44 ~ 1.60
2300	52.9	50.3 ~ 55.5	1.81	1.72 ~ 1.90
2450	52.7	50.1 ~ 55.3	1.95	1.85 ~ 2.05
2600	52.5	49.9 ~ 55.1	2.16	2.05 ~ 2.27
3500	51.3	48.7 ~ 53.9	3.31	3.14 ~ 3.48
5200	49.0	46.6 ~ 51.5	5.30	5.04 ~ 5.57
5300	48.9	46.5 ~ 51.3	5.42	5.15 ~ 5.69
5500	48.6	46.2 ~ 51.0	5.65	5.37 ~ 5.93
5600	48.5	46.1 ~ 50.9	5.77	5.48 ~ 6.06
5800	48.2	45.8 ~ 50.6	6.00	5.70 ~ 6.30

FCC SAR Test Report

The following table gives the recipes for tissue simulating liquids.

Table-3.2 Recipes of Tissue Simulating Liquid

Tissue Type	Bactericide	DGBE	HEC	NaCl	Sucrose	Triton X-100	Water	Diethylene Glycol Mono-hexylether
H750	0.2	-	0.2	1.5	56.0	-	42.1	-
H835	0.2	-	0.2	1.5	57.0	-	41.1	-
H900	0.2	-	0.2	1.4	58.0	-	40.2	-
H1450	-	43.3	-	0.6	-	-	56.1	-
H1640	-	45.8	-	0.5	-	-	53.7	-
H1750	-	47.0	-	0.4	-	-	52.6	-
H1800	-	44.5	-	0.3	-	-	55.2	-
H1900	-	44.5	-	0.2	-	-	55.3	-
H2000	-	44.5	-	0.1	-	-	55.4	-
H2300	-	44.9	-	0.1	-	-	55.0	-
H2450	-	45.0	-	0.1	-	-	54.9	-
H2600	-	45.1	-	0.1	-	-	54.8	-
H3500	-	8.0	-	0.2	-	20.0	71.8	-
H5G	-	-	-	-	-	17.2	65.5	17.3
B750	0.2	-	0.2	0.8	48.8	-	50.0	-
B835	0.2	-	0.2	0.9	48.5	-	50.2	-
B900	0.2	-	0.2	0.9	48.2	-	50.5	-
B1450	-	34.0	-	0.3	-	-	65.7	-
B1640	-	32.5	-	0.3	-	-	67.2	-
B1750	-	31.0	-	0.2	-	-	68.8	-
B1800	-	29.5	-	0.4	-	-	70.1	-
B1900	-	29.5	-	0.3	-	-	70.2	-
B2000	-	30.0	-	0.2	-	-	69.8	-
B2300	-	31.0	-	0.1	-	-	68.9	-
B2450	-	31.4	-	0.1	-	-	68.5	-
B2600	-	31.8	-	0.1	-	-	68.1	-
B3500	-	28.8	-	0.1	-	-	71.1	-
B5G	-	-	-	-	-	10.7	78.6	10.7

3.3 SAR System Verification

The system check verifies that the system operates within its specifications. It is performed daily or before every SAR measurement. The system check uses normal SAR measurements in the flat section of the phantom with a matched dipole at a specified distance. The system verification setup is shown as below.

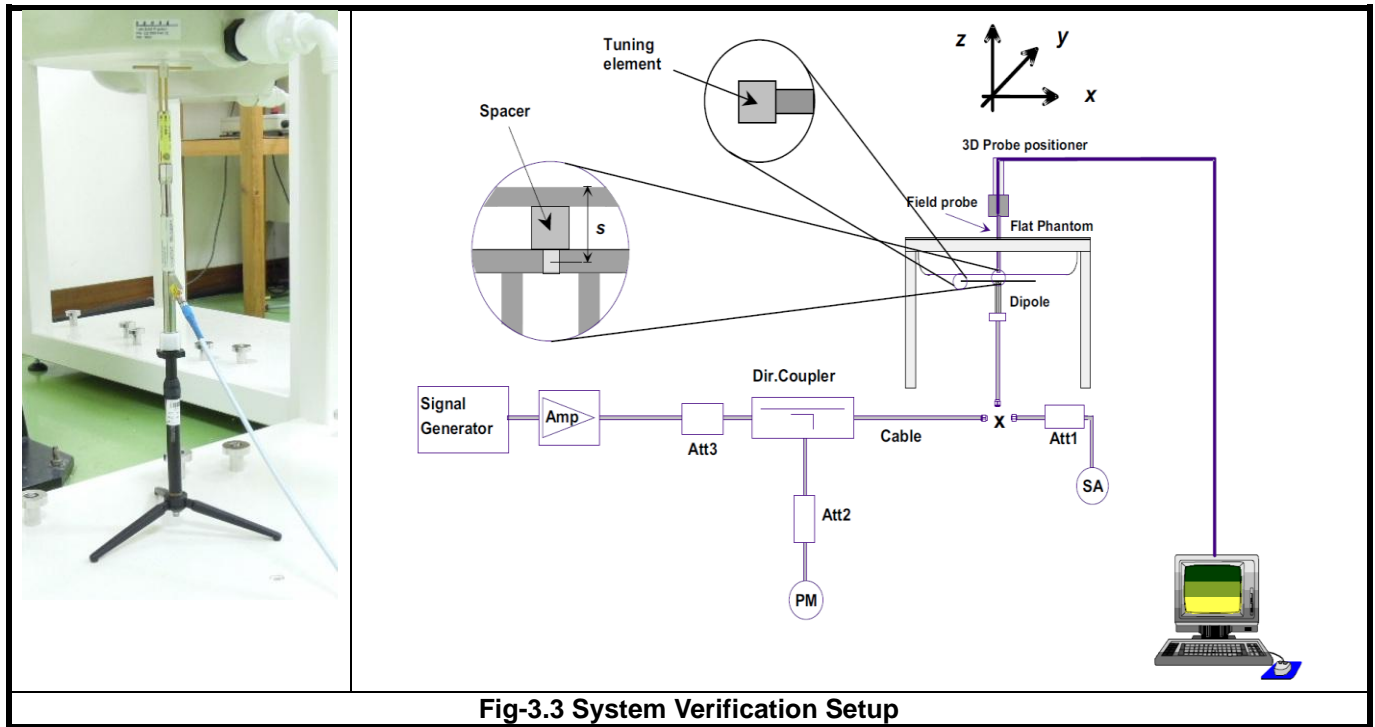

Fig-3.3 System Verification Setup

The validation dipole is placed beneath the flat phantom with the specific spacer in place. The distance spacer is touch the phantom surface with a light pressure at the reference marking and be oriented parallel to the long side of the phantom. The spectrum analyzer measures the forward power at the location of the system check dipole connector. The signal generator is adjusted for the desired forward power (250 mW is used for 700 MHz to 3 GHz, 100 mW is used for 3.5 GHz to 6 GHz) at the dipole connector and the power meter is read at that level. After connecting the cable to the dipole, the signal generator is readjusted for the same reading at power meter.

After system check testing, the SAR result will be normalized to 1W forward input power and compared with the reference SAR value derived from validation dipole certificate report. The deviation of system check should be within 10 %.

3.4 SAR Measurement Procedure

According to the SAR test standard, the recommended procedure for assessing the peak spatial-average SAR value consists of the following steps:

- (a) Power reference measurement
- (b) Area scan
- (c) Zoom scan
- (d) Power drift measurement

The SAR measurement procedures for each of test conditions are as follows:

- (a) Make EUT to transmit maximum output power
- (b) Measure conducted output power through RF cable
- (c) Place the EUT in the specific position of phantom
- (d) Perform SAR testing steps on the DASY system
- (e) Record the SAR value

3.4.1 Area & Zoom Scan Procedure

First Area Scan is used to locate the approximate location(s) of the local peak SAR value(s). The measurement grid within an Area Scan is defined by the grid extent, grid step size and grid offset. Next, in order to determine the EM field distribution in a three-dimensional spatial extension, Zoom Scan is required. The Zoom Scan is performed around the highest E-field value to determine the averaged SAR-distribution over 10 g. According to KDB 865664 D01, the resolution for Area and Zoom scan is specified in the table below.

Items	<= 2 GHz	2-3 GHz	3-4 GHz	4-5 GHz	5-6 GHz
Area Scan ($\Delta x, \Delta y$)	<= 15 mm	<= 12 mm	<= 12 mm	<= 10 mm	<= 10 mm
Zoom Scan ($\Delta x, \Delta y$)	<= 8 mm	<= 5 mm	<= 5 mm	<= 4 mm	<= 4 mm
Zoom Scan (Δz)	<= 5 mm	<= 5 mm	<= 4 mm	<= 3 mm	<= 2 mm
Zoom Scan Volume	>= 30 mm	>= 30 mm	>= 28 mm	>= 25 mm	>= 22 mm

Note:

When zoom scan is required and report SAR is <= 1.4 W/kg, the zoom scan resolution of $\Delta x / \Delta y$ (2-3GHz: <= 8 mm, 3-4GHz: <= 7 mm, 4-6GHz: <= 5 mm) may be applied.

3.4.2 Volume Scan Procedure

The volume scan is used for assess overlapping SAR distributions for antennas transmitting in different frequency bands. It is equivalent to an oversized zoom scan used in standalone measurements. The measurement volume will be used to enclose all the simultaneous transmitting antennas. For antennas transmitting simultaneously in different frequency bands, the volume scan is measured separately in each frequency band. In order to sum correctly to compute the 1g aggregate SAR, the EUT remain in the same test position for all measurements and all volume scan use the same spatial resolution and grid spacing. When all volume scan were completed, the software, SEMCAD postprocessor can combine and subsequently superpose these measurement data to calculating the multiband SAR.

3.4.3 Power Drift Monitoring

All SAR testing is under the EUT install full charged battery and transmit maximum output power. In DASY measurement software, the power reference measurement and power drift measurement procedures are used for monitoring the power drift of EUT during SAR test. Both these procedures measure the field at a specified reference position before and after the SAR testing. The software will calculate the field difference in dB. If the power drift more than 5%, the SAR will be retested.

3.4.4 Spatial Peak SAR Evaluation

The procedure for spatial peak SAR evaluation has been implemented according to the test standard. It can be conducted for 1g and 10g, as well as for user-specific masses. The DASY software includes all numerical procedures necessary to evaluate the spatial peak SAR value.

The base for the evaluation is a "cube" measurement. The measured volume must include the 1g and 10g cubes with the highest averaged SAR values. For that purpose, the center of the measured volume is aligned to the interpolated peak SAR value of a previously performed area scan.

The entire evaluation of the spatial peak values is performed within the post-processing engine (SEMCAD). The system always gives the maximum values for the 1g and 10g cubes. The algorithm to find the cube with highest averaged SAR is divided into the following stages:

- (a) Extraction of the measured data (grid and values) from the Zoom Scan
- (b) Calculation of the SAR value at every measurement point based on all stored data (A/D values and measurement parameters)
- (c) Generation of a high-resolution mesh within the measured volume
- (d) Interpolation of all measured values from the measurement grid to the high-resolution grid
- (e) Extrapolation of the entire 3-D field distribution to the phantom surface over the distance from sensor to surface
- (f) Calculation of the averaged SAR within masses of 1g and 10g

3.4.5 SAR Averaged Methods

In DASY, the interpolation and extrapolation are both based on the modified Quadratic Shepard's method. The interpolation scheme combines a least-square fitted function method and a weighted average method which are the two basic types of computational interpolation and approximation.

Extrapolation routines are used to obtain SAR values between the lowest measurement points and the inner phantom surface. The extrapolation distance is determined by the surface detection distance and the probe sensor offset. The uncertainty increases with the extrapolation distance. To keep the uncertainty within 1% for the 1 g and 10 g cubes, the extrapolation distance should not be larger than 5 mm.

4. SAR Measurement Evaluation

4.1 EUT Configuration and Setting

<Considerations Related to WLAN for Setup and Testing>

In general, various vendor specific external test software and chipset based internal test modes are typically used for SAR measurement. These chipset based test mode utilities are generally hardware and manufacturer dependent, and often include substantial flexibility to reconfigure or reprogram a device. A Wi-Fi device must be configured to transmit continuously at the required data rate, channel bandwidth and signal modulation, using the highest transmission duty factor supported by the test mode tools for SAR measurement. The test frequencies established using test mode must correspond to the actual channel frequencies. When 802.11 frame gaps are accounted for in the transmission, a maximum transmission duty factor of 92 - 96% is typically achievable in most test mode configurations. A minimum transmission duty factor of 85% is required to avoid certain hardware and device implementation issues related to wide range SAR scaling. In addition, a periodic transmission duty factor is required for current generation SAR systems to measure SAR correctly. The reported SAR must be scaled to 100% transmission duty factor to determine compliance at the maximum tune-up tolerance limit.

According to KDB 248227 D01, this device has installed WLAN engineering testing software which can provide continuous transmitting RF signal. During WLAN SAR testing, this device was operated to transmit continuously at the maximum transmission duty with specified transmission mode, operating frequency, lowest data rate, and maximum output power.

Initial Test Configuration

An initial test configuration is determined for OFDM transmission modes in 2.4 GHz and 5 GHz bands according to the channel bandwidth, modulation and data rate combination(s) with the highest maximum output power specified for production units in each standalone and aggregated frequency band. When the same maximum power is specified for multiple transmission modes in a frequency band, the largest channel bandwidth, lowest order modulation, lowest data rate and lowest order 802.11a/g/n/ac mode is used for SAR measurement, on the highest measured output power channel in the initial test configuration, for each frequency band.

Subsequent Test Configuration

SAR measurement requirements for the remaining 802.11 transmission mode configurations that have not been tested in the initial test configuration are determined separately for each standalone and aggregated frequency band, in each exposure condition, according to the maximum output power specified for production units. Additional power measurements may be required to determine if SAR measurements are required for subsequent highest output power channels in a subsequent test configuration. When the highest reported SAR for the initial test configuration according to the initial test position or fixed exposure position requirements, is adjusted by the ratio of the subsequent test configuration to initial test configuration specified maximum output power and the adjusted SAR is ≤ 1.2 W/kg, SAR is not required for that subsequent test configuration.

SAR Test Configuration and Channel Selection

When multiple channel bandwidth configurations in a frequency band have the same specified maximum output power, the initial test configuration is using largest channel bandwidth, lowest order modulation, lowest data rate, and lowest order 802.11 mode (i.e., 802.11a is chosen over 802.11n then 802.11ac or 802.11g is chosen over 802.11n). After an initial test configuration is determined, if multiple test channels have the same measured maximum output power, the channel chosen for SAR measurement is determined according to the following.

- 1) The channel closest to mid-band frequency is selected for SAR measurement.
- 2) For channels with equal separation from mid-band frequency; for example, high and low channels or two mid-band channels, the higher frequency (number) channel is selected for SAR measurement.

Test Reduction for U-NII-1 (5.2 GHz) and U-NII-2A (5.3 GHz) Bands

For devices that operate in both U-NII bands using the same transmitter and antenna(s), SAR test reduction is determined according to the following.

- 1) When the same maximum output power is specified for both bands, begin SAR measurement in U-NII-2A band by applying the OFDM SAR requirements. If the highest reported SAR for a test configuration is ≤ 1.2 W/kg, SAR is not required for U-NII-1 band for that configuration (802.11 mode and exposure condition).
- 2) When different maximum output power is specified for the bands, begin SAR measurement in the band with higher specified maximum output power. The highest reported SAR for the tested configuration is adjusted by the ratio of lower to higher specified maximum output power for the two bands. When the adjusted SAR is ≤ 1.2 W/kg, SAR is not required for the band with lower maximum output power in that test configuration.

<Considerations Related to Bluetooth for Setup and Testing>

This device has installed Bluetooth engineering testing software which can provide continuous transmitting RF signal. During Bluetooth SAR testing, this device was operated to transmit continuously at the maximum transmission duty with specified transmission mode, operating frequency, lowest data rate, and maximum output power.

4.2 EUT Testing Position

For full-size tablet, according to KDB 616217 D04, SAR evaluation is required for back surface and edges of the devices. The back surface and edges of the tablet are tested with the tablet touching the phantom. Exposures from antennas through the front surface of the display section of a tablet are generally limited to the user’s hands. Exposures to hands for typical consumer transmitters used in tablets are not expected to exceed the extremity SAR limit; therefore, SAR evaluation for the front surface of tablet display screens are generally not necessary. When voice mode is supported on a tablet and it is limited to speaker mode or headset operations only, additional SAR testing for this type of voice use is not required.

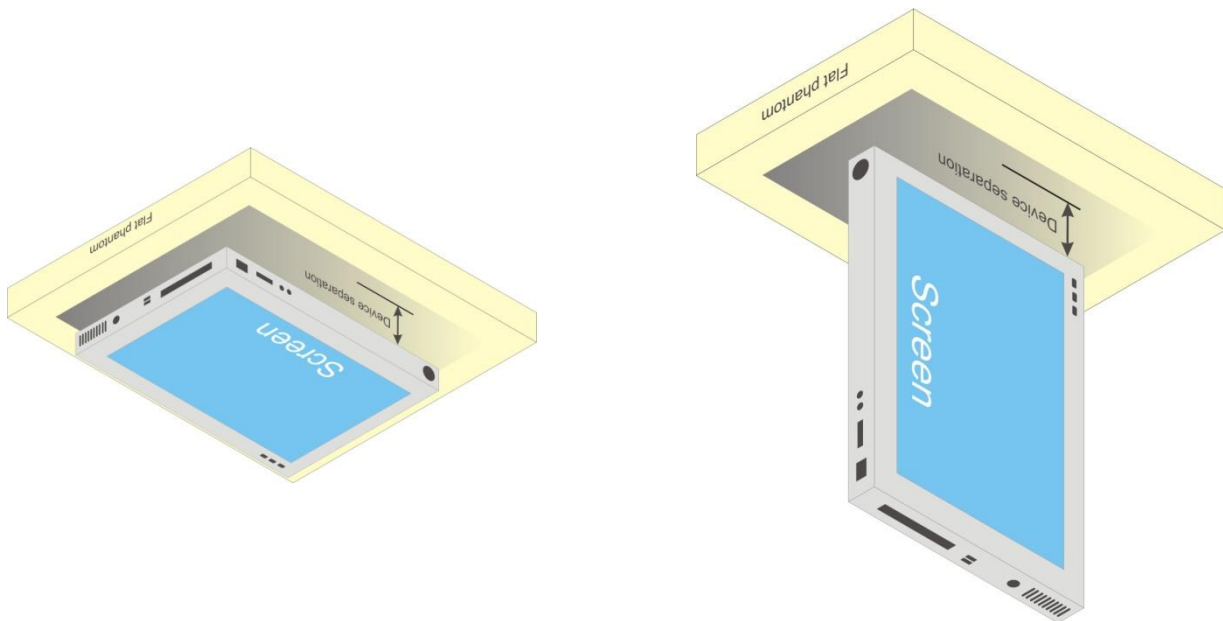

Fig-4.1 Illustration for Tablet Setup

4.2.1 SAR Test Exclusion Evaluations

According to KDB 447498 D01, the SAR test exclusion condition is based on source-based time-averaged maximum conducted output power, adjusted for tune-up tolerance, and the minimum test separation distance required for the exposure conditions. The SAR exclusion threshold is determined by the following formula.

1. For the test separation distance ≤ 50 mm

$$\frac{\text{Max. Tune up Power}_{(mW)}}{\text{Min. Test Separation Distance}_{(mm)}} \times \sqrt{f_{(GHz)}} \leq 3.0 \text{ for SAR-1g, } \leq 7.5 \text{ for SAR-10g}$$

When the minimum test separation distance is < 5 mm, a distance of 5 mm is applied to determine SAR test exclusion.

2. For the test separation distance > 50 mm, and the frequency at 100 MHz to 1500 MHz

$$\left[(\text{Threshold at 50 mm in Step 1}) + (\text{Test Separation Distance} - 50 \text{ mm}) \times \left(\frac{f_{(MHz)}}{150} \right) \right]_{(mW)}$$

3. For the test separation distance > 50 mm, and the frequency at > 1500 MHz to 6 GHz

$$[(\text{Threshold at 50 mm in Step 1}) + (\text{Test Separation Distance} - 50 \text{ mm}) \times 10]_{(mW)}$$

FCC SAR Test Report

<For WLAN Ant-0>

Mode	Max. Tune-up Power (dBm)	Max. Tune-up Power (mW)	Rear Face			Top Side			Bottom Side			Left Side			Right Side		
			Ant. to Surface (mm)	Calculated Result	Require SAR Testing?	Ant. to Surface (mm)	Calculated Result	Require SAR Testing?	Ant. to Surface (mm)	Calculated Result	Require SAR Testing?	Ant. to Surface (mm)	Calculated Result	Require SAR Testing?	Ant. to Surface (mm)	Calculated Result	Require SAR Testing?
WLAN 2.4G	15.0	31.62	5	9.9	YES	159.7 5	1193 mW	No	27.1	1.8	No	5.4	9.2	YES	325.8	2854 mW	No
WLAN 5.2G	13.5	22.39	5	10.3	YES	159.7 5	1163 mW	No	27.1	1.9	No	5.4	9.5	YES	325.8	2824 mW	No
WLAN 5.3G	13.5	22.39	5	10.3	YES	159.7 5	1163 mW	No	27.1	1.9	No	5.4	9.6	YES	325.8	2823 mW	No
WLAN 5.6G	13.5	22.39	5	10.7	YES	159.7 5	1160 mW	No	27.1	2	No	5.4	9.9	YES	325.8	2821 mW	No
WLAN 5.8G	13.5	22.39	5	10.8	YES	159.7 5	1160 mW	No	27.1	2	No	5.4	10	YES	325.8	2820 mW	No

<For BT/WLAN Ant-1>

Mode	Max. Tune-up Power (dBm)	Max. Tune-up Power (mW)	Rear Face			Top Side			Bottom Side			Left Side			Right Side		
			Ant. to Surface (mm)	Calculated Result	Require SAR Testing?	Ant. to Surface (mm)	Calculated Result	Require SAR Testing?	Ant. to Surface (mm)	Calculated Result	Require SAR Testing?	Ant. to Surface (mm)	Calculated Result	Require SAR Testing?	Ant. to Surface (mm)	Calculated Result	Require SAR Testing?
WLAN 2.4G	15.0	31.62	5	9.9	YES	30.4	1.6	No	156.4 5	1160 mW	No	5.4	9.2	YES	325.8	2854 mW	No
WLAN 5.2G	13.5	22.39	5	10.3	YES	30.4	1.7	No	156.4 5	1130 mW	No	5.4	9.5	YES	325.8	2824 mW	No
WLAN 5.3G	13.5	22.39	5	10.3	YES	30.4	1.7	No	156.4 5	1130 mW	No	5.4	9.6	YES	325.8	2823 mW	No
WLAN 5.6G	13.5	22.39	5	10.7	YES	30.4	1.8	No	156.4 5	1127 mW	No	5.4	9.9	YES	325.8	2821 mW	No
WLAN 5.8G	13.5	22.39	5	10.8	YES	30.4	1.8	No	156.4 5	1127 mW	No	5.4	10	YES	325.8	2820 mW	No
BT	6.0	3.98	5	1.3	No	30.4	0.2	No	156.4 5	1160 mW	No	5.4	1.2	No	325.8	2853 mW	No

<For BT/WLAN Ant-0+1>

Mode	Max. Tune-up Power (dBm)	Max. Tune-up Power (mW)	Rear Face			Top Side			Bottom Side			Left Side			Right Side		
			Ant. to Surface (mm)	Calculated Result	Require SAR Testing?	Ant. to Surface (mm)	Calculated Result	Require SAR Testing?	Ant. to Surface (mm)	Calculated Result	Require SAR Testing?	Ant. to Surface (mm)	Calculated Result	Require SAR Testing?	Ant. to Surface (mm)	Calculated Result	Require SAR Testing?
WLAN 2.4G	15.0	31.62	5	9.9	YES	30.4	1.6	No	156.4 5	1160 mW	No	5.4	9.2	YES	325.8	2854 mW	No
WLAN 5.2G	13.5	22.39	5	10.3	YES	30.4	1.7	No	156.4 5	1130 mW	No	5.4	9.5	YES	325.8	2824 mW	No
WLAN 5.3G	13.5	22.39	5	10.3	YES	30.4	1.7	No	156.4 5	1130 mW	No	5.4	9.6	YES	325.8	2823 mW	No
WLAN 5.6G	13.5	22.39	5	10.7	YES	30.4	1.8	No	156.4 5	1127 mW	No	5.4	9.9	YES	325.8	2821 mW	No
WLAN 5.8G	13.5	22.39	5	10.8	YES	30.4	1.8	No	156.4 5	1127 mW	No	5.4	10	YES	325.8	2820 mW	No

Note:

1. When separation distance ≤ 50 mm and the calculated result shown in above table is ≤ 3.0 for SAR-1g exposure condition, or ≤ 7.5 for SAR-10g exposure condition, the SAR testing exclusion is applied.
2. When separation distance > 50 mm and the device output power is less than the calculated result (power threshold, mW) shown in above table, the SAR testing exclusion is applied.

FCC SAR Test Report

4.2.2 Simultaneous Transmission Possibilities

The simultaneous transmission possibilities for this device are listed as below.

Simultaneous TX Combination	Capable Transmit Configurations	Body Exposure Condition
1	WCDMA II (Voice / Data) + WLAN (Data)	Yes
2	WCDMA IV (Voice / Data) + WLAN (Data)	Yes
3	WCDMA V (Voice / Data) + WLAN (Data)	Yes
4	CDMA BC0 (Voice / Data) + WLAN (Data)	Yes
5	CDMA BC1 (Voice / Data) + WLAN (Data)	Yes
6	CDMA BC10 (Voice / Data) + WLAN (Data)	Yes
7	LTE 2 (Data) + WLAN (Data)	Yes
8	LTE 4 (Data) + WLAN (Data)	Yes
9	LTE 5 (Data) + WLAN (Data)	Yes
10	LTE 13 (Data) + WLAN (Data)	Yes
11	LTE 17 (Data) + WLAN (Data)	Yes
12	LTE 25 (Data) + WLAN (Data)	Yes
13	WCDMA II (Voice / Data) + BT (Data)	Yes
14	WCDMA IV (Voice / Data) + BT (Data)	Yes
15	WCDMA V (Voice / Data) + BT (Data)	Yes
16	CDMA BC0 (Voice / Data) + BT (Data)	Yes
17	CDMA BC1 (Voice / Data) + BT (Data)	Yes
18	CDMA BC10 (Voice / Data) + BT (Data)	Yes
19	LTE 2 (Data) + BT (Data)	Yes
20	LTE 4 (Data) + BT (Data)	Yes
21	LTE 5 (Data) + BT (Data)	Yes
22	LTE 13 (Data) + BT (Data)	Yes
23	LTE 17 (Data) + BT (Data)	Yes
24	LTE 25 (Data) + BT (Data)	Yes
25	WCDMA II (Voice / Data) + WLAN (Data) + BT (Data)	Yes
26	WCDMA IV (Voice / Data) + WLAN (Data) + BT (Data)	Yes
27	WCDMA V (Voice / Data) + WLAN (Data) + BT (Data)	Yes
28	CDMA BC0 (Voice / Data) + WLAN (Data) + BT (Data)	Yes
29	CDMA BC1 (Voice / Data) + WLAN (Data) + BT (Data)	Yes
30	CDMA BC10 (Voice / Data) + WLAN (Data) + BT (Data)	Yes
31	LTE 2 (Data) + WLAN (Data) + BT (Data)	Yes
32	LTE 4 (Data) + WLAN (Data) + BT (Data)	Yes
33	LTE 5 (Data) + WLAN (Data) + BT (Data)	Yes
34	LTE 13 (Data) + WLAN (Data) + BT (Data)	Yes
35	LTE 17 (Data) + WLAN (Data) + BT (Data)	Yes
36	LTE 25 (Data) + WLAN (Data) + BT (Data)	Yes

Note:

1. The 2.4G WLAN and 5G WLAN cannot transmit simultaneously.

FCC SAR Test Report

4.3 Tissue Verification

The measuring results for tissue simulating liquid are shown as below.

Test Date	Tissue Type	Frequency (MHz)	Liquid Temp. (°C)	Measured Conductivity (σ)	Measured Permittivity (ϵ_r)	Target Conductivity (σ)	Target Permittivity (ϵ_r)	Conductivity Deviation (%)	Permittivity Deviation (%)
Oct. 06, 2016	Body	2450	23.5	1.997	52.334	1.95	52.7	2.41	-0.69
Oct. 08, 2016	Body	2450	23.3	1.997	52.222	1.95	52.7	2.41	-0.91
Oct. 11, 2016	Body	2450	23.1	1.979	51.085	1.95	52.7	1.49	-3.06
Oct. 11, 2016	Body	5300	23.1	5.531	47.111	5.42	48.9	2.05	-3.66
Oct. 12, 2016	Body	5300	23.2	5.530	47.135	5.42	48.9	2.03	-3.61
Oct. 08, 2016	Body	5600	23.3	5.928	46.609	5.77	48.5	2.74	-3.90
Oct. 12, 2016	Body	5600	23.2	5.930	46.622	5.77	48.5	2.77	-3.87
Oct. 13, 2016	Body	5600	23.3	6.057	48.579	5.77	48.5	4.97	0.16
Oct. 06, 2016	Body	5800	23.4	6.113	48.226	6.00	48.2	1.88	0.05
Oct. 07, 2016	Body	5800	23.2	6.203	46.259	6.00	48.2	3.38	-4.03
Oct. 13, 2016	Body	5800	23.3	6.057	48.579	6.00	48.2	0.95	0.79

Note:

The dielectric properties of the tissue simulating liquid must be measured within 24 hours before the SAR testing and within $\pm 5\%$ of the target values. Liquid temperature during the SAR testing must be within $\pm 2^\circ\text{C}$.

4.4 System Validation

The SAR measurement system was validated according to procedures in KDB 865664 D01. The validation status in tabulated summary is as below.

Test Date	Probe S/N	Calibration Point		Measured Conductivity (σ)	Measured Permittivity (ϵ_r)	Validation for CW			Validation for Modulation		
						Sensitivity Range	Probe Linearity	Probe Isotropy	Modulation Type	Duty Factor	PAR
Oct. 06, 2016	3650	Body	2450	1.997	52.334	Pass	Pass	Pass	OFDM	N/A	Pass
Oct. 08, 2016	3650	Body	2450	1.997	52.222	Pass	Pass	Pass	OFDM	N/A	Pass
Oct. 11, 2016	3650	Body	2450	1.979	51.085	Pass	Pass	Pass	OFDM	N/A	Pass
Oct. 11, 2016	3650	Body	5300	5.531	47.111	Pass	Pass	Pass	OFDM	N/A	Pass
Oct. 12, 2016	3650	Body	5300	5.530	47.135	Pass	Pass	Pass	OFDM	N/A	Pass
Oct. 08, 2016	3650	Body	5600	5.928	46.609	Pass	Pass	Pass	OFDM	N/A	Pass
Oct. 12, 2016	3650	Body	5600	5.930	46.622	Pass	Pass	Pass	OFDM	N/A	Pass
Oct. 13, 2016	3864	Body	5600	6.057	48.579	Pass	Pass	Pass	OFDM	N/A	Pass
Oct. 06, 2016	3650	Body	5800	6.113	48.226	Pass	Pass	Pass	OFDM	N/A	Pass
Oct. 07, 2016	3650	Body	5800	6.203	46.259	Pass	Pass	Pass	OFDM	N/A	Pass
Oct. 13, 2016	3864	Body	5800	6.057	48.579	Pass	Pass	Pass	OFDM	N/A	Pass

FCC SAR Test Report

4.5 System Verification

The measuring result for system verification is tabulated as below.

Test Date	Mode	Frequency (MHz)	1W Target SAR-1g (W/kg)	Measured SAR-1g (W/kg)	Normalized to 1W SAR-1g (W/kg)	Deviation (%)	Dipole S/N	Probe S/N	DAE S/N
Oct. 06, 2016	Body	2450	51.40	12.20	48.80	-5.06	869	3650	861
Oct. 08, 2016	Body	2450	51.40	12.00	48.00	-6.61	869	3650	861
Oct. 11, 2016	Body	2450	51.40	12.10	48.40	-5.84	869	3650	861
Oct. 11, 2016	Body	5300	76.40	7.73	77.30	1.18	1040	3650	861
Oct. 12, 2016	Body	5300	76.40	7.69	76.90	0.65	1040	3650	861
Oct. 08, 2016	Body	5600	78.40	7.89	78.90	0.64	1040	3650	861
Oct. 12, 2016	Body	5600	78.40	7.70	77.00	-1.79	1040	3650	861
Oct. 13, 2016	Body	5600	78.40	7.73	77.30	-1.40	1040	3864	1431
Oct. 06, 2016	Body	5800	75.20	7.80	78.00	3.72	1040	3650	861
Oct. 07, 2016	Body	5800	75.20	7.98	79.80	6.12	1040	3650	861
Oct. 13, 2016	Body	5800	75.20	7.74	77.40	2.93	1040	3864	1431

Note:

Comparing to the reference SAR value provided by SPEAG, the validation data should be within its specification of 10 %. The result indicates the system check can meet the variation criterion and the plots can be referred to Appendix A of this report.

FCC SAR Test Report

4.6 Maximum Output Power

4.6.1 Maximum Conducted Power

The maximum conducted average power (Unit: dBm) including tune-up tolerance is shown as below.

Mode	Tx Antenna	2.4G WLAN	5.2G WLAN	5.3G WLAN	5.6G WLAN	5.8G WLAN
802.11b	Ant-0	CH1-11: 15.0 CH12: 15.0 CH13: 11.0	N/A	N/A	N/A	N/A
	Ant-1	CH1-11: 15.0 CH12: 12.5 CH13: 6.5	N/A	N/A	N/A	N/A
802.11g	Ant-0	CH1-11: 15.0 CH12: 12.0 CH13: 0	N/A	N/A	N/A	N/A
	Ant-1	CH1-11: 15.0 CH12: 11.0 CH13: -1.5	N/A	N/A	N/A	N/A
802.11a	Ant-0	N/A	13.5	13.5	13.5	13.5
	Ant-1	N/A	13.0	13.5	13.5	13.5
802.11n HT20	Ant-0	N/A	13.5	13.5	13.5	13.5
	Ant-1	CH1-11: 15.0 CH12: 12.0 CH13: -0.5	13.5	13.5	13.5	13.5
	Ant-0+ Ant-1	CH1-11: 15.0 CH12: 11.0 CH13: -1.0	13.5	13.5	13.5	13.5
802.11n HT40	Ant-0	CH1-11: 15.0 CH12: 11.0 CH13: -1.0	13.5	13.5	13.5	13.5
	Ant-1	CH3: 15.0 CH4-8: 15.0 CH9: 13.0 CH10: 9.5 CH11: -1.0	13.5	13.5	13.5	13.5
	Ant-0+ Ant-1	CH3: 13.5 CH4-8: 15.0 CH9: 9.5 CH10: 6.5 CH11: -1.0	13.5	13.5	13.5	13.5
802.11ac VHT80	Ant-0	CH3: 13.5 CH6-9: 15.0 CH10: 10.0 CH11: -2.5	13.5	13.5	13.5	13.5
	Ant-1	N/A	13.5	13.5	13.5	13.5
	Ant-0+ Ant-1	N/A	13.5	13.5	13.5	13.5

Mode	2.4G Bluetooth
Bluetooth DH	6.0

FCC SAR Test Report

4.6.2 Measured Conducted Power Result

The measuring conducted average power (Unit: dBm) is shown as below.

<WLAN 2.4G>

Mode	802.11b				
Channel / Frequency (MHz)	1 (2412)	6 (2437)	11 (2462)	12 (2467)	13 (2472)
Average Power (Ant-0)	14.70	14.83	14.76	14.51	10.96
Average Power (Ant-1)	14.87	14.93	14.86	12.38	6.41
Mode	802.11n (HT40)				
Channel / Frequency (MHz)	3 (2422)	6 (2437)	9 (2452)	10 (2457)	11 (2462)
Average Power (Ant-0 + Ant-1)	13.42	14.72	14.68	9.93	-3.59

<WLAN 5.3G>

Mode	802.11ac (VHT80)
Channel / Frequency (MHz)	58 (5290)
Average Power (Ant-0)	13.48
Average Power (Ant-1)	13.48
Average Power (Ant-0 + Ant-1)	13.20

<WLAN 5.6G>

Mode	802.11ac (VHT80)	
Channel / Frequency (MHz)	106 (5530)	138 (5690)
Average Power (Ant-0)	13.40	13.48
Average Power (Ant-1)	13.35	13.50
Average Power (Ant-0 + Ant-1)	13.39	13.38

<WLAN 5.8G>

Mode	802.11ac (VHT80)
Channel / Frequency (MHz)	155 (5775)
Average Power (Ant-0)	13.44
Average Power (Ant-1)	13.47
Average Power (Ant-0 + Ant-1)	13.30

<Bluetooth>

Mode	Bluetooth		
Channel / Frequency (MHz)	0 (2402)	39 (2441)	78 (2480)
Average Power	5.16	5.82	5.00

4.7 SAR Testing Results

4.7.1 SAR Test Reduction Considerations

<KDB 447498 D01, General RF Exposure Guidance>

Testing of other required channels within the operating mode of a frequency band is not required when the reported SAR for the mid-band or highest output power channel is:

- (1) ≤ 0.8 W/kg or 2.0 W/kg, for 1-g or 10-g respectively, when the transmission band is ≤ 100 MHz
- (2) ≤ 0.6 W/kg or 1.5 W/kg, for 1-g or 10-g respectively, when the transmission band is between 100 MHz and 200 MHz
- (3) ≤ 0.4 W/kg or 1.0 W/kg, for 1-g or 10-g respectively, when the transmission band is ≥ 200 MHz

<KDB 248227 D01, SAR Guidance for Wi-Fi Transmitters>

- (1) For handsets operating next to ear, hotspot mode or mini-tablet configurations, the initial test position procedures were applied. The test position with the highest extrapolated peak SAR will be used as the initial test position. When the reported SAR of initial test position is ≤ 0.4 W/kg, SAR testing for remaining test positions is not required. Otherwise, SAR is evaluated at the subsequent highest peak SAR positions until the reported SAR result is ≤ 0.8 W/kg or all test positions are measured.
- (2) For WLAN 2.4 GHz, the highest measured maximum output power channel for DSSS was selected for SAR measurement. When the reported SAR is ≤ 0.8 W/kg, no further SAR testing is required. Otherwise, SAR is evaluated at the next highest measured output power channel. When any reported SAR is > 1.2 W/kg, SAR is required for the third channel. For OFDM modes (802.11g/n), SAR is not required when the highest reported SAR for DSSS is adjusted by the ratio of OFDM to DSSS specified maximum output power and it is ≤ 1.2 W/kg.
- (3) For WLAN 5 GHz, the initial test configuration was selected according to the transmission mode with the highest maximum output power. When the reported SAR of initial test configuration is > 0.8 W/kg, SAR is required for the subsequent highest measured output power channel until the reported SAR result is ≤ 1.2 W/kg or all required channels are measured. For other transmission modes, SAR is not required when the highest reported SAR for initial test configuration is adjusted by the ratio of subsequent test configuration to initial test configuration specified maximum output power and it is ≤ 1.2 W/kg.
- (4) For WLAN MIMO mode, the power-based standalone SAR test exclusion or the sum of SAR provision in KDB 447498 to determine simultaneous transmission SAR test exclusion should be applied. Otherwise, SAR for MIMO mode will be measured with all applicable antennas transmitting simultaneously at the specified maximum output power of MIMO operation.

FCC SAR Test Report

4.7.2 SAR Results for Body Exposure Condition (Separation Distance is 0 cm Gap)

Plot No.	Band	Mode	Test Position	Ch.	Tx Antenna	Max. Tune-up Power (dBm)	Measured Conducted Power (dBm)	Scaling Factor	Power Drift (dB)	Measured SAR-1g (W/kg)	Scaled SAR-1g (W/kg)
	2.4G WLAN	802.11b	Rear Face	6	0	15.0	14.83	1.04	0.04	0.303	0.32
	2.4G WLAN	802.11b	Rear Face	6	1	15.0	14.93	1.02	0.01	0.227	0.23
	2.4G WLAN	802.11n HT40	Rear Face	6	0+1	15.0	14.72	1.07	0.06	0.151	0.16
	2.4G WLAN	802.11b	Left Side	6	0	15.0	14.83	1.04	-0.09	0.458	0.48
	2.4G WLAN	802.11b	Left Side	6	1	15.0	14.93	1.02	-0.1	0.501	0.51
	2.4G WLAN	802.11n HT40	Left Side	6	0+1	15.0	14.72	1.07	0.02	0.245	0.26
01	2.4G WLAN	802.11b	Left-tilt Side	6	0	15.0	14.83	1.04	0.07	0.534	0.56
	2.4G WLAN	802.11b	Left-tilt Side	6	1	15.0	14.93	1.02	-0.11	0.442	0.45
	2.4G WLAN	802.11n HT40	Left-tilt Side	6	0+1	15.0	14.72	1.07	0.09	0.299	0.32
	2.4G WLAN	802.11b	Top Side	6	0	15.0	14.83	1.04	0.04	0.00649	0.01
	2.4G WLAN	802.11b	Top Side	6	1	15.0	14.93	1.02	0.02	0.091	0.09
	2.4G WLAN	802.11n HT40	Top Side	6	0+1	15.0	14.72	1.07	0.06	0.047	0.05
	2.4G WLAN	802.11b	Top-tilt Side	6	0	15.0	14.83	1.04	-0.05	0.021	0.02
	2.4G WLAN	802.11b	Top-tilt Side	6	1	15.0	14.93	1.02	0.03	0.205	0.21
	2.4G WLAN	802.11n HT40	Top-tilt Side	6	0+1	15.0	14.72	1.07	0.06	0.111	0.12
	5.3G WLAN	802.11ac VH80	Rear Face	58	0	13.5	13.48	1.00	-0.13	0.227	0.23
	5.3G WLAN	802.11ac VH80	Rear Face	58	1	13.5	13.48	1.00	0.13	0.171	0.17
	5.3G WLAN	802.11ac VH80	Rear Face	58	0+1	13.5	13.20	1.07	0.06	0.083	0.09
02	5.3G WLAN	802.11ac VH80	Left Side	58	0	13.5	13.48	1.00	-0.15	0.846	0.85
	5.3G WLAN	802.11ac VH80	Left Side	58	0	13.5	13.48	1.00	0.04	0.814	0.82
	5.3G WLAN	802.11ac VH80	Left Side	58	1	13.5	13.48	1.00	0.11	0.639	0.64
	5.3G WLAN	802.11ac VH80	Left Side	58	0+1	13.5	13.20	1.07	0.13	0.361	0.39
	5.3G WLAN	802.11ac VH80	Left-tilt Side	58	0	13.5	13.48	1.00	-0.14	0.498	0.50
	5.3G WLAN	802.11ac VH80	Left-tilt Side	58	1	13.5	13.48	1.00	0.11	0.344	0.35
	5.3G WLAN	802.11ac VH80	Left-tilt Side	58	0+1	13.5	13.20	1.07	-0.11	0.242	0.26
	5.3G WLAN	802.11ac VH80	Top Side	58	0	13.5	13.48	1.00	0.02	0.014	0.01
	5.3G WLAN	802.11ac VH80	Top Side	58	1	13.5	13.48	1.00	0.01	0.193	0.19
	5.3G WLAN	802.11ac VH80	Top Side	58	0+1	13.5	13.20	1.07	0.09	0.092	0.10
	5.3G WLAN	802.11ac VH80	Top-tilt Side	58	0	13.5	13.48	1.00	0	0	0.00
	5.3G WLAN	802.11ac VH80	Top-tilt Side	58	1	13.5	13.48	1.00	0.08	0.319	0.32
	5.3G WLAN	802.11ac VH80	Top-tilt Side	58	0+1	13.5	13.20	1.07	0	0.134	0.14
	5.6G WLAN	802.11ac VH80	Rear Face	138	0	13.5	13.48	1.00	0.07	0.269	0.27
	5.6G WLAN	802.11ac VH80	Rear Face	138	1	13.5	13.50	1.00	0.03	0.224	0.22
	5.6G WLAN	802.11ac VH80	Rear Face	106	0+1	13.5	13.39	1.03	-0.01	0.102	0.10
03	5.6G WLAN	802.11ac VH80	Left Side	138	0	13.5	13.48	1.00	0.06	1.15	1.16
	5.6G WLAN	802.11ac VH80	Left Side	138	0	13.5	13.48	1.00	0.06	1.13	1.14
	5.6G WLAN	802.11ac VH80	Left Side	106	0	13.5	13.40	1.02	0.03	0.94	0.96
	5.6G WLAN	802.11ac VH80	Left Side	138	1	13.5	13.50	1.00	0.07	0.958	0.96
	5.6G WLAN	802.11ac VH80	Left Side	106	1	13.5	13.35	1.04	0.03	0.912	0.94
	5.6G WLAN	802.11ac VH80	Left Side	106	0+1	13.5	13.39	1.03	0.04	0.442	0.45
	5.6G WLAN	802.11ac VH80	Left-tilt Side	138	0	13.5	13.48	1.00	0.08	0.748	0.75
	5.6G WLAN	802.11ac VH80	Left-tilt Side	138	1	13.5	13.50	1.00	-0.09	0.534	0.53
	5.6G WLAN	802.11ac VH80	Left-tilt Side	106	0+1	13.5	13.39	1.03	-0.05	0.298	0.31
	5.6G WLAN	802.11ac VH80	Top Side	138	0	13.5	13.48	1.00	0	0	0.00
	5.6G WLAN	802.11ac VH80	Top Side	138	1	13.5	13.50	1.00	0.02	0.335	0.34
	5.6G WLAN	802.11ac VH80	Top Side	106	0+1	13.5	13.39	1.03	0.01	0.151	0.15
	5.6G WLAN	802.11ac VH80	Top-tilt Side	138	0	13.5	13.48	1.00	0	0	0.00
	5.6G WLAN	802.11ac VH80	Top-tilt Side	138	1	13.5	13.50	1.00	0.01	0.296	0.30
	5.6G WLAN	802.11ac VH80	Top-tilt Side	106	0+1	13.5	13.39	1.03	0	0.149	0.15

FCC SAR Test Report

Plot No.	Band	Mode	Test Position	Ch.	Tx Antenna	Max. Tune-up Power (dBm)	Measured Conducted Power (dBm)	Scaling Factor	Power Drift (dB)	Measured SAR-1g (W/kg)	Scaled SAR-1g (W/kg)
	5.8G WLAN	802.11ac VH80	Rear Face	155	0	13.5	13.44	1.01	0.01	0.254	0.26
	5.8G WLAN	802.11ac VH80	Rear Face	155	1	13.5	13.47	1.01	0.02	0.219	0.22
	5.8G WLAN	802.11ac VH80	Rear Face	155	0+1	13.5	13.30	1.05	0.01	0.116	0.12
04	5.8G WLAN	802.11ac VH80	Left Side	155	0	13.5	13.44	1.01	0.02	1.08	1.10
	5.8G WLAN	802.11ac VH80	Left Side	155	0	13.5	13.44	1.01	0.02	1.05	1.06
	5.8G WLAN	802.11ac VH80	Left Side	155	1	13.5	13.47	1.01	-0.14	0.984	0.99
	5.8G WLAN	802.11ac VH80	Left Side	155	0+1	13.5	13.30	1.05	-0.16	0.581	0.61
	5.8G WLAN	802.11ac VH80	Left-tilt Side	155	0	13.5	13.44	1.01	0.13	0.665	0.67
	5.8G WLAN	802.11ac VH80	Left-tilt Side	155	1	13.5	13.47	1.01	-0.07	0.477	0.48
	5.8G WLAN	802.11ac VH80	Left-tilt Side	155	0+1	13.5	13.30	1.05	0.15	0.224	0.23
	5.8G WLAN	802.11ac VH80	Top Side	155	0	13.5	13.44	1.01	0	0	0.00
	5.8G WLAN	802.11ac VH80	Top Side	155	1	13.5	13.47	1.01	0.01	0.351	0.35
	5.8G WLAN	802.11ac VH80	Top Side	155	0+1	13.5	13.30	1.05	0.15	0.206	0.22
	5.8G WLAN	802.11ac VH80	Top-tilt Side	155	0	13.5	13.44	1.01	0	0	0.00
	5.8G WLAN	802.11ac VH80	Top-tilt Side	155	1	13.5	13.47	1.01	0	0.353	0.36
	5.8G WLAN	802.11ac VH80	Top-tilt Side	155	0+1	13.5	13.30	1.05	0.01	0.189	0.20

Plot No.	Band	Test Position	Ch.	Max. Tune-up Power (dBm)	Measured Conducted Power (dBm)	Scaling Factor	Power Drift (dB)	Measured SAR-1g (W/kg)	Scaled SAR-1g (W/kg)
	Bluetooth	Rear Face	39	6.0	5.82	1.04	0.07	0.000101	0.00
05	Bluetooth	Left Side	39	6.0	5.82	1.04	0.09	0.00546	0.01
	Bluetooth	Left-tilt Side	39	6.0	5.82	1.04	0.03	0.00303	0.00
	Bluetooth	Top Side	39	6.0	5.82	1.04	0.07	0.00285	0.00
	Bluetooth	Top-tilt Side	39	6.0	5.82	1.04	0.02	0.00227	0.00
	Bluetooth	Bottom Side	39	6.0	5.82	1.04	0	0.00	0.00

FCC SAR Test Report

4.7.3 SAR Measurement Variability

According to KDB 865664 D01, SAR measurement variability was assessed for each frequency band, which is determined by the SAR probe calibration point and tissue-equivalent medium used for the device measurements. When both head and body tissue-equivalent media are required for SAR measurements in a frequency band, the variability measurement procedures should be applied to the tissue medium with the highest measured SAR, using the highest measured SAR configuration for that tissue-equivalent medium. Alternatively, if the highest measured SAR for both head and body tissue-equivalent media are ≤ 1.45 W/kg and the ratio of these highest SAR values, i.e., largest divided by smallest value, is ≤ 1.10 , the highest SAR configuration for either head or body tissue-equivalent medium may be used to perform the repeated measurement. These additional measurements are repeated after the completion of all measurements requiring the same head or body tissue-equivalent medium in a frequency band. The test device should be returned to ambient conditions (normal room temperature) with the battery fully charged before it is re-mounted on the device holder for the repeated measurement(s) to minimize any unexpected variations in the repeated results.

SAR repeated measurement procedure:

1. When the highest measured SAR is < 0.80 W/kg, repeated measurement is not required.
2. When the highest measured SAR is ≥ 0.80 W/kg, repeat that measurement once.
3. If the ratio of largest to smallest SAR for the original and first repeated measurements is > 1.20 , or when the original or repeated measurement is ≥ 1.45 W/kg, perform a second repeated measurement.
4. If the ratio of largest to smallest SAR for the original, first and second repeated measurements is > 1.20 , and the original, first or second repeated measurement is ≥ 1.5 W/kg, perform a third repeated measurement.

Band	Mode	Test Position	Ch.	Original Measured SAR-1g (W/kg)	1st Repeated SAR-1g (W/kg)	L/S Ratio	2nd Repeated SAR-1g (W/kg)	L/S Ratio	3rd Repeated SAR-1g (W/kg)	L/S Ratio
5.3G WLAN	802.11ac VH80	Left Side	58	0.846	0.814	1.04	N/A	N/A	N/A	N/A
5.6G WLAN	802.11ac VH80	Left Side	138	1.15	1.13	1.02	N/A	N/A	N/A	N/A
5.8G WLAN	802.11ac VH80	Left Side	155	1.08	1.05	1.03	N/A	N/A	N/A	N/A

FCC SAR Test Report

4.7.4 Simultaneous Multi-band Transmission Evaluation

<Estimated SAR Calculation>

According to KDB 447498 D01, when standalone SAR test exclusion applies to an antenna that transmits simultaneously with other antennas, the standalone SAR was estimated according to following formula to result in substantially conservative SAR values of ≤ 0.4 W/kg to determine simultaneous transmission SAR test exclusion.

$$\text{Estimated SAR} = \frac{\text{Max. Tune up Power}_{(mW)}}{\text{Min. Test Separation Distance}_{(mm)}} \times \frac{\sqrt{f_{(GHz)}}}{7.5}$$

If the minimum test separation distance is < 5 mm, a distance of 5 mm is used for estimated SAR calculation. When the test separation distance is > 50 mm, the 0.4 W/kg is used for SAR-1g.

Mode / Band	Frequency (GHz)	Max. Tune-up Power (dBm)	Test Position	Separation Distance (mm)	Estimated SAR (W/kg)
WCDMA II	1.9076	24.0	Body	5	0.40
WCDMA IV	1.7526	24.0	Body	5	0.40
WCDMA V	0.8466	24.0	Body	5	0.40
CDMA BC0	0.84831	25.0	Body	5	0.40
CDMA BC1	1.90875	25.0	Body	5	0.40
CDMA BC10	0.8231	25.0	Body	5	0.40
LTE 2	1.9093	24.0	Body	5	0.40
LTE 4	1.7543	24.0	Body	5	0.40
LTE 5	0.8483	24.0	Body	5	0.40
LTE 13	0.7845	24.0	Body	5	0.40
LTE 17	0.7135	24.0	Body	5	0.40
LTE 25	1.9143	24.0	Body	5	0.40
WLAN (DTS)	2.462	15.0	Body	5	0.40
WLAN (5.2G)	5.24	13.5	Body	5	0.40
WLAN (5.3G)	5.32	13.5	Body	5	0.40
WLAN (5.6G)	5.7	13.5	Body	5	0.40
WLAN (5.8G)	5.825	13.5	Body	5	0.40
BT (DSS)	2.48	6.0	Body	5	0.17

Note:

1. The separation distance is determined from the outer housing of the EUT to the user.
2. When standalone SAR testing is not required, an estimated SAR can be applied to determine simultaneous transmission SAR test exclusion.

FCC SAR Test Report

<SAR Summation Analysis>

Simultaneous transmission SAR test exclusion is determined for each operating configuration and exposure condition according to the reported standalone SAR of each applicable simultaneous transmitting antenna. When the sum of SAR_{1g} of all simultaneously transmitting antennas in an operating mode and exposure condition combination is within the SAR limit (SAR_{1g} 1.6 W/kg), the simultaneous transmission SAR is not required. When the sum of SAR_{1g} is greater than the SAR limit (SAR_{1g} 1.6 W/kg), SAR test exclusion is determined by the SPLSR.

No.	Conditions (SAR1 + SAR2 + SAR3)	Exposure Condition	Test Position	Max. SAR1	Max. SAR2	Max. SAR3	SAR Summation	SPLSR Analysis
1	WCDMA II + WLAN (DTS) + BT (DSS)	Body	Rear Face	0.574	0.32	0.00	0.894	Σ SAR < 1.6, Not required
			Top Side	1.235	0.09	0.00	1.325	Σ SAR < 1.6, Not required
			Top-tilt Side	1.378	0.21	0.00	1.588	Σ SAR < 1.6, Not required
			Bottom Side	0.40	0.40	0.00	0.800	Σ SAR < 1.6, Not required
			Left Side	0.40	0.51	0.01	0.920	Σ SAR < 1.6, Not required
			Left-tilt Side	0.40	0.56	0.00	0.960	Σ SAR < 1.6, Not required
			Right Side	0.083	0.40	0.17	0.653	Σ SAR < 1.6, Not required
2	WCDMA II + WLAN (NII) + BT (DSS)	Body	Rear Face	0.574	0.27	0.00	0.844	Σ SAR < 1.6, Not required
			Top Side	1.235	0.35	0.00	1.585	Σ SAR < 1.6, Not required
			Top-tilt Side	1.378	0.36	0.00	1.738	Analyzed as below
			Bottom Side	0.40	0.40	0.00	0.800	Σ SAR < 1.6, Not required
			Left Side	0.40	1.16	0.01	1.570	Σ SAR < 1.6, Not required
			Left-tilt Side	0.40	0.75	0.00	1.150	Σ SAR < 1.6, Not required
			Right Side	0.083	0.40	0.17	0.653	Σ SAR < 1.6, Not required

FCC SAR Test Report

No.	Conditions (SAR1 + SAR2 + SAR3)	Exposure Condition	Test Position	Max. SAR1	Max. SAR2	Max. SAR3	SAR Summation	SPLSR Analysis
3	WCDMA IV + WLAN (DTS) + BT (DSS)	Body	Rear Face	0.532	0.32	0.00	0.852	Σ SAR < 1.6, Not required
			Top Side	1.389	0.09	0.00	1.479	Σ SAR < 1.6, Not required
			Top-tilt Side	1.335	0.21	0.00	1.545	Σ SAR < 1.6, Not required
			Bottom Side	0.40	0.40	0.00	0.800	Σ SAR < 1.6, Not required
			Left Side	0.40	0.51	0.01	0.920	Σ SAR < 1.6, Not required
			Left-tilt Side	0.40	0.56	0.00	0.960	Σ SAR < 1.6, Not required
			Right Side	0.136	0.40	0.17	0.706	Σ SAR < 1.6, Not required
4	WCDMA IV + WLAN (NII) + BT (DSS)	Body	Rear Face	0.532	0.27	0.00	0.802	Σ SAR < 1.6, Not required
			Top Side	1.389	0.35	0.00	1.739	Analyzed as below
			Top-tilt Side	1.335	0.36	0.00	1.695	Analyzed as below
			Bottom Side	0.40	0.40	0.00	0.800	Σ SAR < 1.6, Not required
			Left Side	0.40	1.16	0.01	1.570	Σ SAR < 1.6, Not required
			Left-tilt Side	0.40	0.75	0.00	1.150	Σ SAR < 1.6, Not required
			Right Side	0.136	0.40	0.17	0.706	Σ SAR < 1.6, Not required
5	WCDMA V + WLAN (DTS) + BT (DSS)	Body	Rear Face	0.555	0.32	0.00	0.875	Σ SAR < 1.6, Not required
			Top Side	1.047	0.09	0.00	1.137	Σ SAR < 1.6, Not required
			Top-tilt Side	1.067	0.21	0.00	1.277	Σ SAR < 1.6, Not required
			Bottom Side	0.40	0.40	0.00	0.800	Σ SAR < 1.6, Not required
			Left Side	0.40	0.51	0.01	0.920	Σ SAR < 1.6, Not required
			Left-tilt Side	0.40	0.56	0.00	0.960	Σ SAR < 1.6, Not required
			Right Side	0.198	0.40	0.17	0.768	Σ SAR < 1.6, Not required
6	WCDMA V + WLAN (NII) + BT (DSS)	Body	Rear Face	0.555	0.27	0.00	0.825	Σ SAR < 1.6, Not required
			Top Side	1.047	0.35	0.00	1.397	Σ SAR < 1.6, Not required
			Top-tilt Side	1.067	0.36	0.00	1.427	Σ SAR < 1.6, Not required
			Bottom Side	0.40	0.40	0.00	0.800	Σ SAR < 1.6, Not required
			Left Side	0.40	1.16	0.01	1.570	Σ SAR < 1.6, Not required
			Left-tilt Side	0.40	0.75	0.00	1.150	Σ SAR < 1.6, Not required
			Right Side	0.198	0.40	0.17	0.768	Σ SAR < 1.6, Not required

FCC SAR Test Report

No.	Conditions (SAR1 + SAR2 + SAR3)	Exposure Condition	Test Position	Max. SAR1	Max. SAR2	Max. SAR3	SAR Summation	SPLSR Analysis
7	CDMA BC0 + WLAN (DTS) + BT (DSS)	Body	Rear Face	0.551	0.32	0.00	0.871	Σ SAR < 1.6, Not required
			Top Side	1.234	0.09	0.00	1.324	Σ SAR < 1.6, Not required
			Top-tilt Side	1.139	0.21	0.00	1.349	Σ SAR < 1.6, Not required
			Bottom Side	0.40	0.40	0.00	0.800	Σ SAR < 1.6, Not required
			Left Side	0.40	0.51	0.01	0.920	Σ SAR < 1.6, Not required
			Left-tilt Side	0.40	0.56	0.00	0.960	Σ SAR < 1.6, Not required
			Right Side	0.311	0.40	0.17	0.881	Σ SAR < 1.6, Not required
8	CDMA BC0 + WLAN (NII) + BT (DSS)	Body	Rear Face	0.551	0.27	0.00	0.821	Σ SAR < 1.6, Not required
			Top Side	1.234	0.35	0.00	1.584	Σ SAR < 1.6, Not required
			Top-tilt Side	1.139	0.36	0.00	1.499	Σ SAR < 1.6, Not required
			Bottom Side	0.40	0.40	0.00	0.800	Σ SAR < 1.6, Not required
			Left Side	0.40	1.16	0.01	1.570	Σ SAR < 1.6, Not required
			Left-tilt Side	0.40	0.75	0.00	1.150	Σ SAR < 1.6, Not required
			Right Side	0.311	0.40	0.17	0.881	Σ SAR < 1.6, Not required
9	CDMA BC1 + WLAN (DTS) + BT (DSS)	Body	Rear Face	0.549	0.32	0.00	0.869	Σ SAR < 1.6, Not required
			Top Side	1.209	0.09	0.00	1.299	Σ SAR < 1.6, Not required
			Top-tilt Side	1.399	0.21	0.00	1.609	Analyzed as below
			Bottom Side	0.40	0.40	0.00	0.800	Σ SAR < 1.6, Not required
			Left Side	0.40	0.51	0.01	0.920	Σ SAR < 1.6, Not required
			Left-tilt Side	0.40	0.56	0.00	0.960	Σ SAR < 1.6, Not required
			Right Side	0.13	0.40	0.17	0.700	Σ SAR < 1.6, Not required
10	CDMA BC1 + WLAN (NII) + BT (DSS)	Body	Rear Face	0.549	0.27	0.00	0.819	Σ SAR < 1.6, Not required
			Top Side	1.209	0.35	0.00	1.559	Σ SAR < 1.6, Not required
			Top-tilt Side	1.399	0.36	0.00	1.759	Analyzed as below
			Bottom Side	0.40	0.40	0.00	0.800	Σ SAR < 1.6, Not required
			Left Side	0.40	1.16	0.01	1.570	Σ SAR < 1.6, Not required
			Left-tilt Side	0.40	0.75	0.00	1.150	Σ SAR < 1.6, Not required
			Right Side	0.13	0.40	0.17	0.700	Σ SAR < 1.6, Not required

FCC SAR Test Report

No.	Conditions (SAR1 + SAR2 + SAR3)	Exposure Condition	Test Position	Max. SAR1	Max. SAR2	Max. SAR3	SAR Summation	SPLSR Analysis
11	CDMA BC10 + WLAN (DTS) + BT (DSS)	Body	Rear Face	0.491	0.32	0.00	0.811	Σ SAR < 1.6, Not required
			Top Side	1.027	0.09	0.00	1.117	Σ SAR < 1.6, Not required
			Top-tilt Side	1.098	0.21	0.00	1.308	Σ SAR < 1.6, Not required
			Bottom Side	0.40	0.40	0.00	0.800	Σ SAR < 1.6, Not required
			Left Side	0.40	0.51	0.01	0.920	Σ SAR < 1.6, Not required
			Left-tilt Side	0.40	0.56	0.00	0.960	Σ SAR < 1.6, Not required
			Right Side	0.214	0.40	0.17	0.784	Σ SAR < 1.6, Not required
12	CDMA BC10 + WLAN (NII) + BT (DSS)	Body	Rear Face	0.491	0.27	0.00	0.761	Σ SAR < 1.6, Not required
			Top Side	1.027	0.35	0.00	1.377	Σ SAR < 1.6, Not required
			Top-tilt Side	1.098	0.36	0.00	1.458	Σ SAR < 1.6, Not required
			Bottom Side	0.40	0.40	0.00	0.800	Σ SAR < 1.6, Not required
			Left Side	0.40	1.16	0.01	1.570	Σ SAR < 1.6, Not required
			Left-tilt Side	0.40	0.75	0.00	1.150	Σ SAR < 1.6, Not required
			Right Side	0.214	0.40	0.17	0.784	Σ SAR < 1.6, Not required
13	LTE 2 + WLAN (DTS) + BT (DSS)	Body	Rear Face	0.468	0.32	0.00	0.788	Σ SAR < 1.6, Not required
			Top Side	1.225	0.09	0.00	1.315	Σ SAR < 1.6, Not required
			Top-tilt Side	1.397	0.21	0.00	1.607	Analyzed as below
			Bottom Side	0.40	0.40	0.00	0.800	Σ SAR < 1.6, Not required
			Left Side	0.40	0.51	0.01	0.920	Σ SAR < 1.6, Not required
			Left-tilt Side	0.40	0.56	0.00	0.960	Σ SAR < 1.6, Not required
			Right Side	0.13	0.40	0.17	0.700	Σ SAR < 1.6, Not required
14	LTE 2 + WLAN (NII) + BT (DSS)	Body	Rear Face	0.468	0.27	0.00	0.738	Σ SAR < 1.6, Not required
			Top Side	1.225	0.35	0.00	1.575	Σ SAR < 1.6, Not required
			Top-tilt Side	1.397	0.36	0.00	1.757	Analyzed as below
			Bottom Side	0.40	0.40	0.00	0.800	Σ SAR < 1.6, Not required
			Left Side	0.40	1.16	0.01	1.570	Σ SAR < 1.6, Not required
			Left-tilt Side	0.40	0.75	0.00	1.150	Σ SAR < 1.6, Not required
			Right Side	0.13	0.40	0.17	0.700	Σ SAR < 1.6, Not required

FCC SAR Test Report

No.	Conditions (SAR1 + SAR2 + SAR3)	Exposure Condition	Test Position	Max. SAR1	Max. SAR2	Max. SAR3	SAR Summation	SPLSR Analysis
15	LTE 4 + WLAN (DTS) + BT (DSS)	Body	Rear Face	0.61	0.32	0.00	0.930	Σ SAR < 1.6, Not required
			Top Side	1.375	0.09	0.00	1.465	Σ SAR < 1.6, Not required
			Top-tilt Side	1.059	0.21	0.00	1.269	Σ SAR < 1.6, Not required
			Bottom Side	0.40	0.40	0.00	0.800	Σ SAR < 1.6, Not required
			Left Side	0.40	0.51	0.01	0.920	Σ SAR < 1.6, Not required
			Left-tilt Side	0.40	0.56	0.00	0.960	Σ SAR < 1.6, Not required
			Right Side	0.20	0.40	0.17	0.770	Σ SAR < 1.6, Not required
16	LTE 4 + WLAN (NII) + BT (DSS)	Body	Rear Face	0.61	0.27	0.00	0.880	Σ SAR < 1.6, Not required
			Top Side	1.375	0.35	0.00	1.725	Analyzed as below
			Top-tilt Side	1.059	0.36	0.00	1.419	Σ SAR < 1.6, Not required
			Bottom Side	0.40	0.40	0.00	0.800	Σ SAR < 1.6, Not required
			Left Side	0.40	1.16	0.01	1.570	Σ SAR < 1.6, Not required
			Left-tilt Side	0.40	0.75	0.00	1.150	Σ SAR < 1.6, Not required
			Right Side	0.20	0.40	0.17	0.770	Σ SAR < 1.6, Not required
17	LTE 5 + WLAN (DTS) + BT (DSS)	Body	Rear Face	0.617	0.32	0.00	0.937	Σ SAR < 1.6, Not required
			Top Side	1.069	0.09	0.00	1.159	Σ SAR < 1.6, Not required
			Top-tilt Side	1.081	0.21	0.00	1.291	Σ SAR < 1.6, Not required
			Bottom Side	0.40	0.40	0.00	0.800	Σ SAR < 1.6, Not required
			Left Side	0.40	0.51	0.01	0.920	Σ SAR < 1.6, Not required
			Left-tilt Side	0.40	0.56	0.00	0.960	Σ SAR < 1.6, Not required
			Right Side	0.21	0.40	0.17	0.780	Σ SAR < 1.6, Not required
18	LTE 5 + WLAN (NII) + BT (DSS)	Body	Rear Face	0.617	0.27	0.00	0.887	Σ SAR < 1.6, Not required
			Top Side	1.069	0.35	0.00	1.419	Σ SAR < 1.6, Not required
			Top-tilt Side	1.081	0.36	0.00	1.441	Σ SAR < 1.6, Not required
			Bottom Side	0.40	0.40	0.00	0.800	Σ SAR < 1.6, Not required
			Left Side	0.40	1.16	0.01	1.570	Σ SAR < 1.6, Not required
			Left-tilt Side	0.40	0.75	0.00	1.150	Σ SAR < 1.6, Not required
			Right Side	0.21	0.40	0.17	0.780	Σ SAR < 1.6, Not required

FCC SAR Test Report

No.	Conditions (SAR1 + SAR2 + SAR3)	Exposure Condition	Test Position	Max. SAR1	Max. SAR2	Max. SAR3	SAR Summation	SPLSR Analysis
19	LTE 13 + WLAN (DTS) + BT (DSS)	Body	Rear Face	0.486	0.32	0.00	0.806	Σ SAR < 1.6, Not required
			Top Side	0.949	0.09	0.00	1.039	Σ SAR < 1.6, Not required
			Top-tilt Side	1.245	0.21	0.00	1.455	Σ SAR < 1.6, Not required
			Bottom Side	0.40	0.40	0.00	0.800	Σ SAR < 1.6, Not required
			Left Side	0.40	0.51	0.01	0.920	Σ SAR < 1.6, Not required
			Left-tilt Side	0.40	0.56	0.00	0.960	Σ SAR < 1.6, Not required
			Right Side	0.208	0.40	0.17	0.778	Σ SAR < 1.6, Not required
20	LTE 13 + WLAN (NII) + BT (DSS)	Body	Rear Face	0.486	0.27	0.00	0.756	Σ SAR < 1.6, Not required
			Top Side	0.949	0.35	0.00	1.299	Σ SAR < 1.6, Not required
			Top-tilt Side	1.245	0.36	0.00	1.605	Analyzed as below
			Bottom Side	0.40	0.40	0.00	0.800	Σ SAR < 1.6, Not required
			Left Side	0.40	1.16	0.01	1.570	Σ SAR < 1.6, Not required
			Left-tilt Side	0.40	0.75	0.00	1.150	Σ SAR < 1.6, Not required
			Right Side	0.208	0.40	0.17	0.778	Σ SAR < 1.6, Not required
21	LTE 17 + WLAN (DTS) + BT (DSS)	Body	Rear Face	0.533	0.32	0.00	0.853	Σ SAR < 1.6, Not required
			Top Side	0.617	0.09	0.00	0.707	Σ SAR < 1.6, Not required
			Top-tilt Side	0.896	0.21	0.00	1.106	Σ SAR < 1.6, Not required
			Bottom Side	0.40	0.40	0.00	0.800	Σ SAR < 1.6, Not required
			Left Side	0.40	0.51	0.01	0.920	Σ SAR < 1.6, Not required
			Left-tilt Side	0.40	0.56	0.00	0.960	Σ SAR < 1.6, Not required
			Right Side	0.166	0.40	0.17	0.736	Σ SAR < 1.6, Not required
22	LTE 17 + WLAN (NII) + BT (DSS)	Body	Rear Face	0.533	0.27	0.00	0.803	Σ SAR < 1.6, Not required
			Top Side	0.617	0.35	0.00	0.967	Σ SAR < 1.6, Not required
			Top-tilt Side	0.896	0.36	0.00	1.256	Σ SAR < 1.6, Not required
			Bottom Side	0.40	0.40	0.00	0.800	Σ SAR < 1.6, Not required
			Left Side	0.40	1.16	0.01	1.570	Σ SAR < 1.6, Not required
			Left-tilt Side	0.40	0.75	0.00	1.150	Σ SAR < 1.6, Not required
			Right Side	0.166	0.40	0.17	0.736	Σ SAR < 1.6, Not required

FCC SAR Test Report

No.	Conditions (SAR1 + SAR2 + SAR3)	Exposure Condition	Test Position	Max. SAR1	Max. SAR2	Max. SAR3	SAR Summation	SPLSR Analysis
23	LTE 25 + WLAN (DTS) + BT (DSS)	Body	Rear Face	0.458	0.32	0.00	0.778	Σ SAR < 1.6, Not required
			Top Side	1.282	0.09	0.00	1.372	Σ SAR < 1.6, Not required
			Top-tilt Side	1.316	0.21	0.00	1.526	Σ SAR < 1.6, Not required
			Bottom Side	0.40	0.40	0.00	0.800	Σ SAR < 1.6, Not required
			Left Side	0.40	0.51	0.01	0.920	Σ SAR < 1.6, Not required
			Left-tilt Side	0.40	0.56	0.00	0.960	Σ SAR < 1.6, Not required
			Right Side	0.111	0.40	0.17	0.681	Σ SAR < 1.6, Not required
24	LTE 25 + WLAN (NII) + BT (DSS)	Body	Rear Face	0.458	0.27	0.00	0.728	Σ SAR < 1.6, Not required
			Top Side	1.282	0.35	0.00	1.632	Analyzed as below
			Top-tilt Side	1.316	0.36	0.00	1.676	Analyzed as below
			Bottom Side	0.40	0.40	0.00	0.800	Σ SAR < 1.6, Not required
			Left Side	0.40	1.16	0.01	1.570	Σ SAR < 1.6, Not required
			Left-tilt Side	0.40	0.75	0.00	1.150	Σ SAR < 1.6, Not required
			Right Side	0.111	0.40	0.17	0.681	Σ SAR < 1.6, Not required

<SAR to Peak Location Separation Ratio Analysis>

The simultaneous transmitting antennas in each operating mode and exposure condition combination are considered one pair at a time to determine the SPLSR. When SAR is measured for both antennas in the pair, the peak location separation distance is computed by the following formula.

$$\text{Peak Location Separation Distance} = \sqrt{(x_1 - x_2)^2 + (y_1 - y_2)^2 + (z_1 - z_2)^2}$$

Where (x_1, y_1, z_1) and (x_2, y_2, z_2) are the coordinates of the extrapolated peak SAR locations in the area or zoom scans.

When standalone test exclusion applies, SAR is estimated; the peak location is assumed to be at the feed-point or geometric center of the antenna. Due to curvatures on the SAM phantom, when SAR is estimated for one of the antennas in an antenna pair, the measured peak SAR location will be translated onto the test device to determine the peak location separation for the antenna pair.

The SPLSR is determined by the following formula.

$$\text{SPLSR} = \frac{(\text{SAR}_1 + \text{SAR}_2)^{1.5}}{R_i}$$

Where SAR_1 and SAR_2 are the highest reported or estimated SAR for each antenna in the pair, and R_i is the separation distance between the peak SAR locations for the antenna pair in mm.

When the SPLSR is ≤ 0.04 , the simultaneous transmission SAR is not required. Otherwise, the enlarged zoom scan and volume scan post-processing procedures will be performed.

FCC SAR Test Report

Conditions	Exposure Condition	Test Position	SAR Value (W/kg)	Coordinates			Peak Location Separation Distance (R _i , mm)	SPLSR	Simultaneous Transmission SAR Test
				x	y	z			
WCDMA II Ch9538	Body	Top-tilt	1.378	-7.7	-89.6	2.13	246.2	0.01	SPLSR ≤ 0.04, Not required
802.11ac VH80 CH155		Side	0.36	-0.5	156.5	3.3			

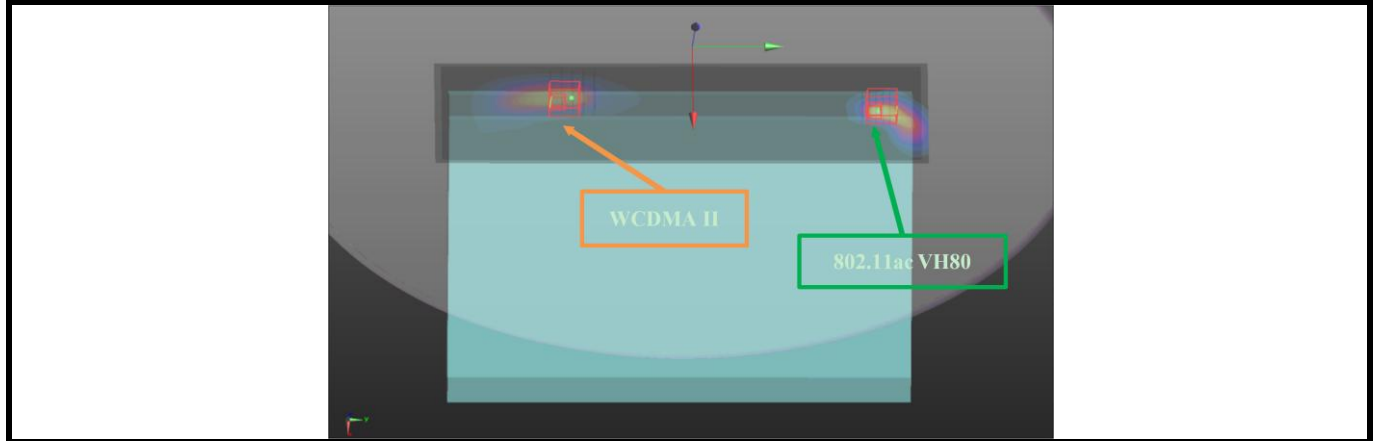

Conditions	Exposure Condition	Test Position	SAR Value (W/kg)	Coordinates			Peak Location Separation Distance (R _i , mm)	SPLSR	Simultaneous Transmission SAR Test
				x	y	z			
WCDMA II Ch9538	Body	Top-tilt	1.378	-7.7	-89.6	2.13	72.2	0.02	SPLSR ≤ 0.04, Not required
Bluetooth Ch39		Side	0	-40.7	-28.5	21.85			

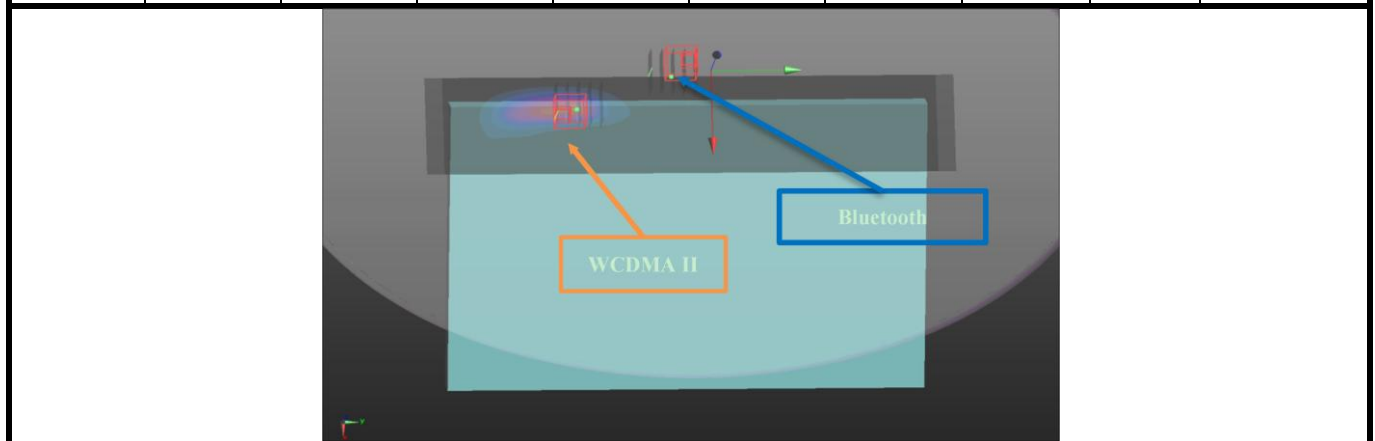

FCC SAR Test Report

Conditions	Exposure Condition	Test Position	SAR Value (W/kg)	Coordinates			Peak Location Separation Distance (R _i , mm)	SPLSR	Simultaneous Transmission SAR Test
				x	y	z			
802.11ac VH80 CH155	Body	Top-tilt Side	0.36	-0.5	156.5	3.3	190.2	0.00	SPLSR ≤ 0.04, Not required
Bluetooth Ch39			0	-40.7	-28.5	21.85			

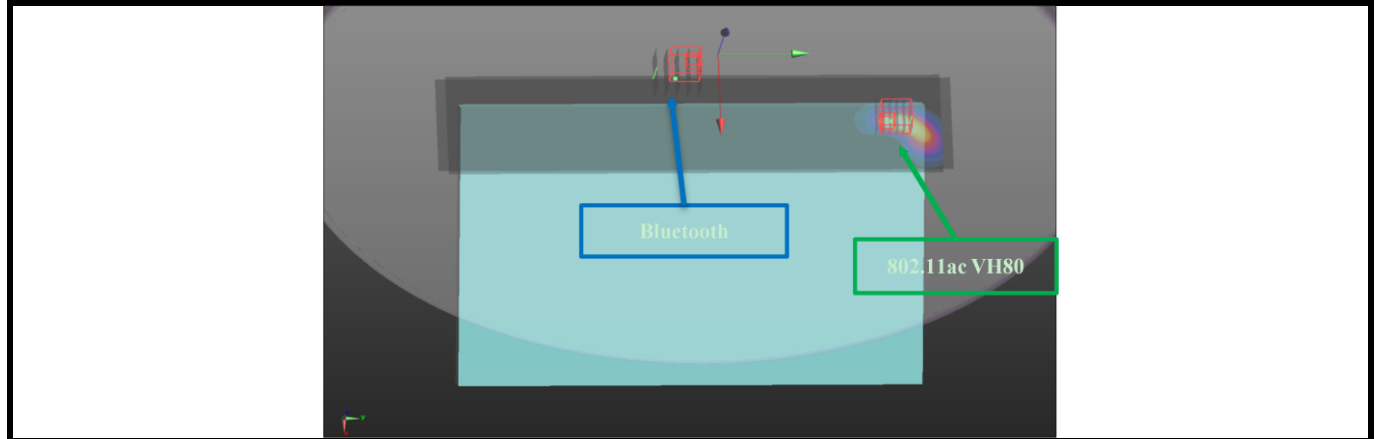

Conditions	Exposure Condition	Test Position	SAR Value (W/kg)	Coordinates			Peak Location Separation Distance (R _i , mm)	SPLSR	Simultaneous Transmission SAR Test
				x	y	z			
WCDMA IV Ch1513	Body	Top Side	1.389	0.5	123.5	1.3	276.1	0.01	SPLSR ≤ 0.04, Not required
802.11ac VH80 CH155			0.35	5.5	-152.5	5.53			

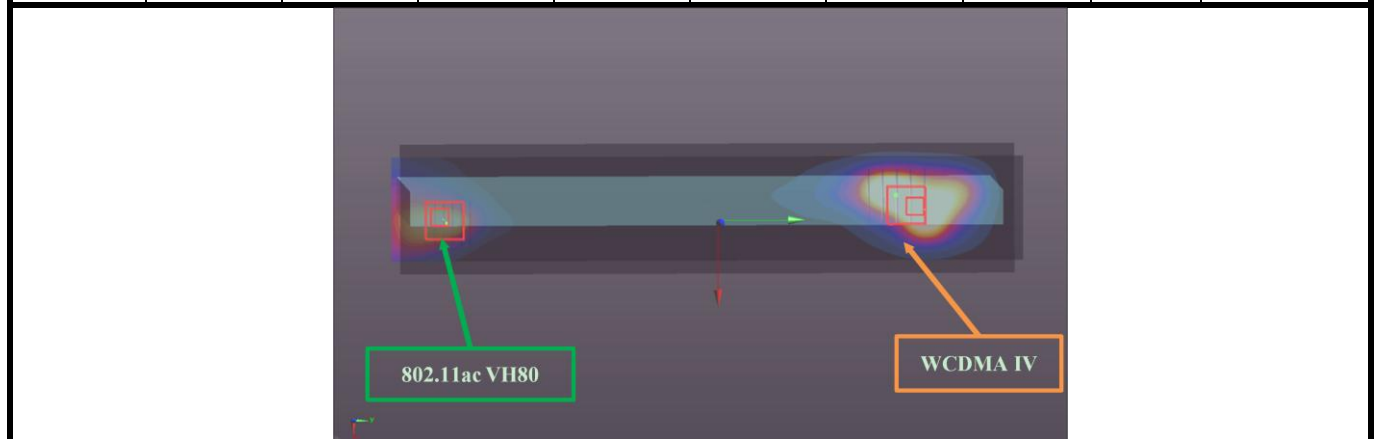

FCC SAR Test Report

Conditions	Exposure Condition	Test Position	SAR Value (W/kg)	Coordinates			Peak Location Separation Distance (R _i , mm)	SPLSR	Simultaneous Transmission SAR Test
				x	y	z			
WCDMA IV Ch1513	Body	Top Side	1.389	0.5	123.5	1.3	267.5	0.01	SPLSR ≤ 0.04, Not required
Bluetooth Ch39			0	-9.3	-143.6	10.88			

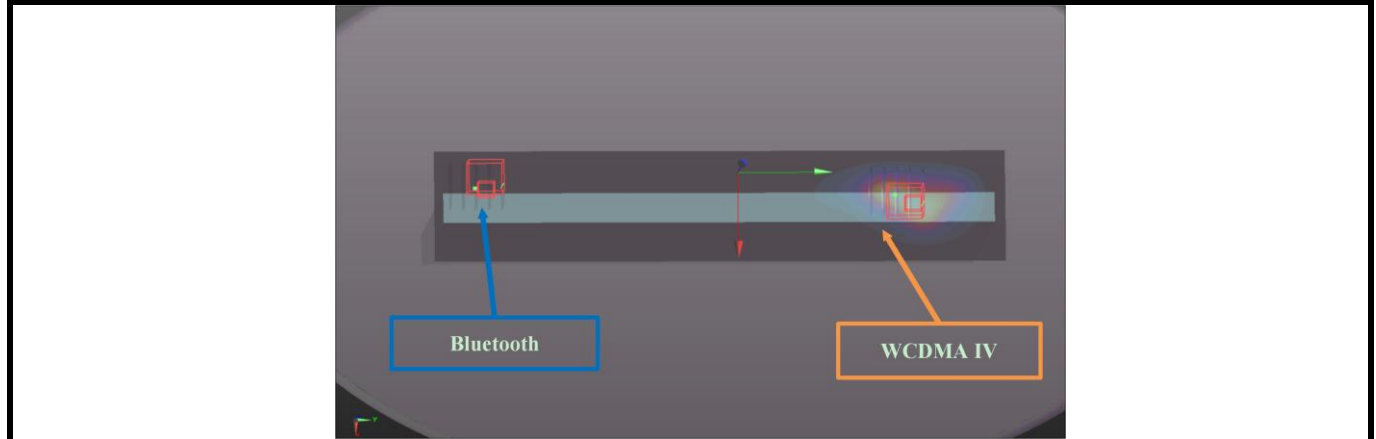

Conditions	Exposure Condition	Test Position	SAR Value (W/kg)	Coordinates			Peak Location Separation Distance (R _i , mm)	SPLSR	Simultaneous Transmission SAR Test
				x	y	z			
802.11ac VH80 CH155	Body	Top Side	0.35	5.5	-152.5	5.53	18.1	0.01	SPLSR ≤ 0.04, Not required
Bluetooth Ch39			0	-9.3	-143.6	10.88			

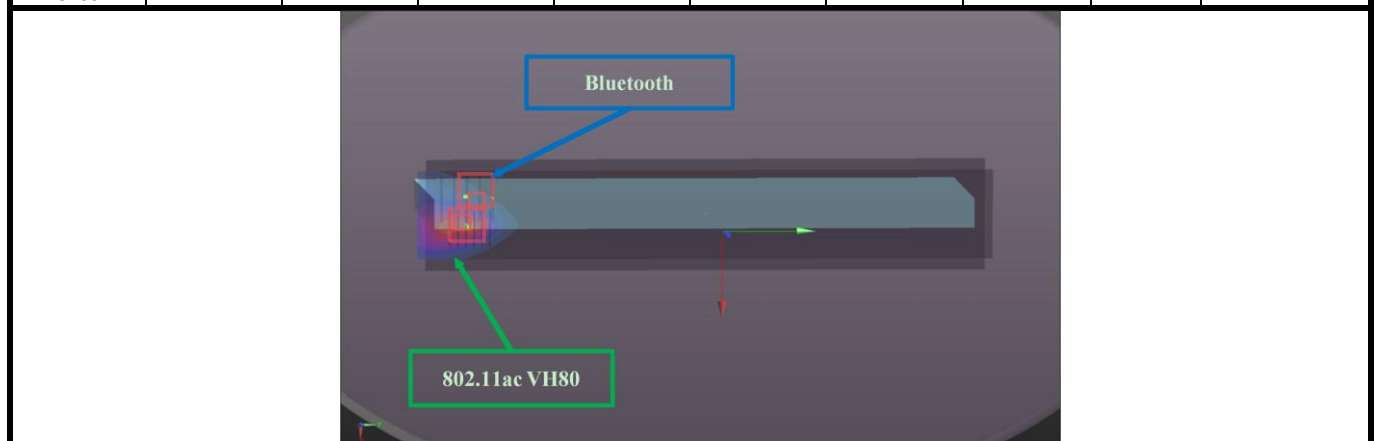

FCC SAR Test Report

Conditions	Exposure Condition	Test Position	SAR Value (W/kg)	Coordinates			Peak Location Separation Distance (R _i , mm)	SPLSR	Simultaneous Transmission SAR Test
				x	y	z			
WCDMA IV Ch1513	Body	Top-tilt	1.335	-6.01	-95.2	2.07	251.8	0.01	SPLSR ≤ 0.04, Not required
802.11ac VH80 CH155		Side	0.36	-0.5	156.5	3.3			

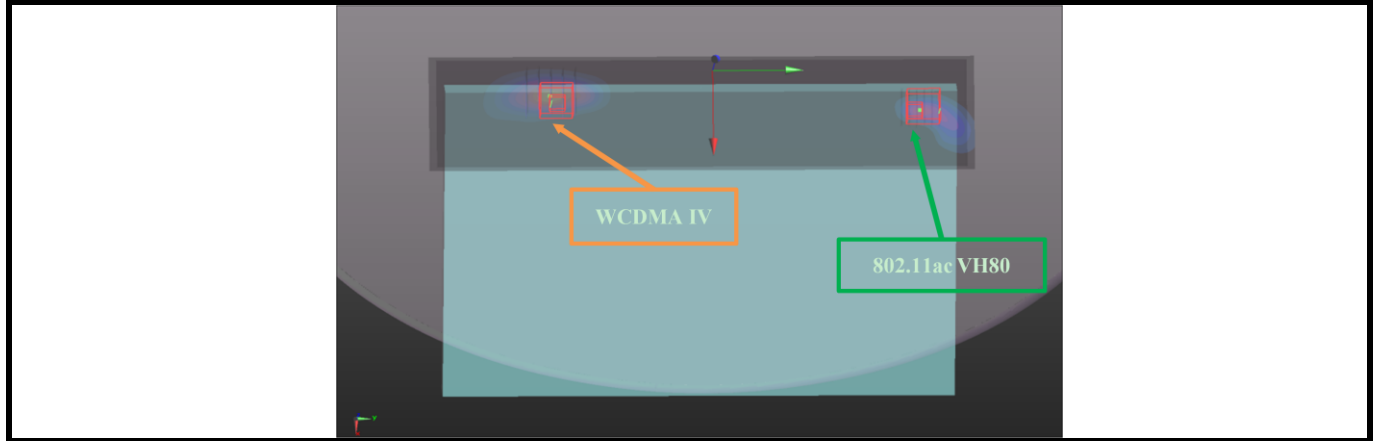

Conditions	Exposure Condition	Test Position	SAR Value (W/kg)	Coordinates			Peak Location Separation Distance (R _i , mm)	SPLSR	Simultaneous Transmission SAR Test
				x	y	z			
WCDMA IV Ch1513	Body	Top-tilt	1.335	-6.01	-95.2	2.07	77.7	0.02	SPLSR ≤ 0.04, Not required
Bluetooth Ch39		Side	0	-40.7	-28.5	21.85			

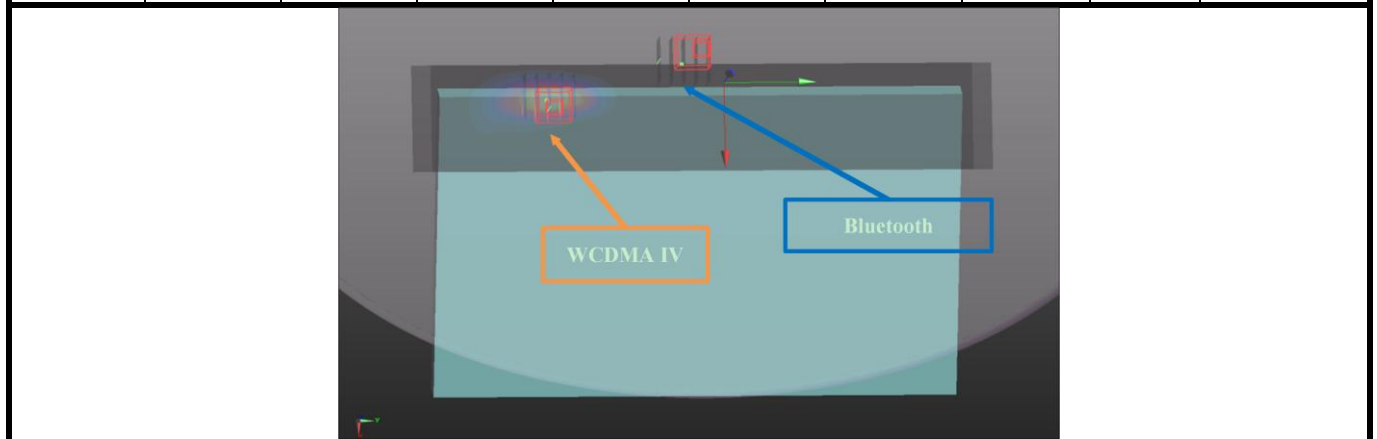

FCC SAR Test Report

Conditions	Exposure Condition	Test Position	SAR Value (W/kg)	Coordinates			Peak Location Separation Distance (R _i , mm)	SPLSR	Simultaneous Transmission SAR Test
				x	y	z			
802.11ac VH80 CH155	Body	Top-tilt Side	0.36	-0.5	156.5	3.3	190.2	0.00	SPLSR ≤ 0.04, Not required
Bluetooth Ch39			0	-40.7	-28.5	21.85			

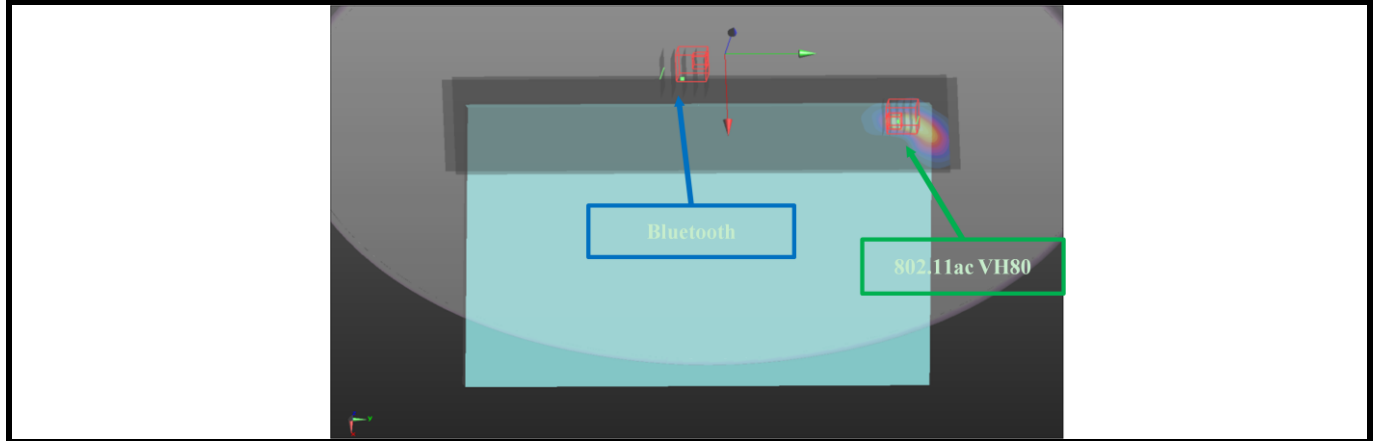

Conditions	Exposure Condition	Test Position	SAR Value (W/kg)	Coordinates			Peak Location Separation Distance (R _i , mm)	SPLSR	Simultaneous Transmission SAR Test
				x	y	z			
CDMA BC1 Ch600	Body	Top-tilt Side	1.399	-6.8	-92	2.14	245.2	0.01	SPLSR ≤ 0.04, Not required
2.4G WALN Ch6			0.21	-4	153.2	6.13			

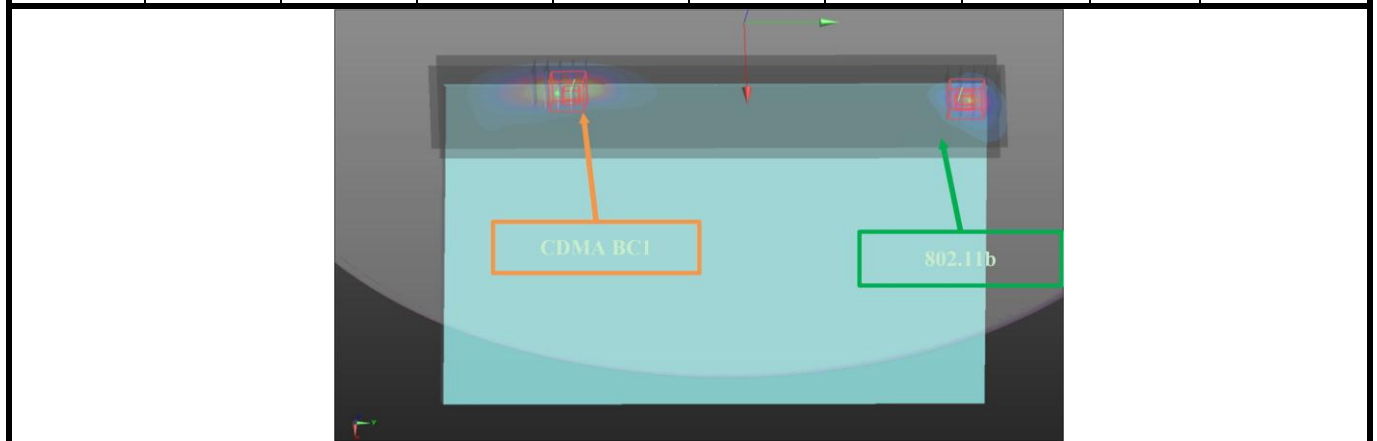

FCC SAR Test Report

Conditions	Exposure Condition	Test Position	SAR Value (W/kg)	Coordinates			Peak Location Separation Distance (R _i , mm)	SPLSR	Simultaneous Transmission SAR Test
				x	y	z			
CDMA BC1 Ch600	Body	Top-tilt Side	1.399	-6.8	-92	2.14	74.6	0.02	SPLSR ≤ 0.04, Not required
Bluetooth Ch39			0	-40.7	-28.5	21.85			

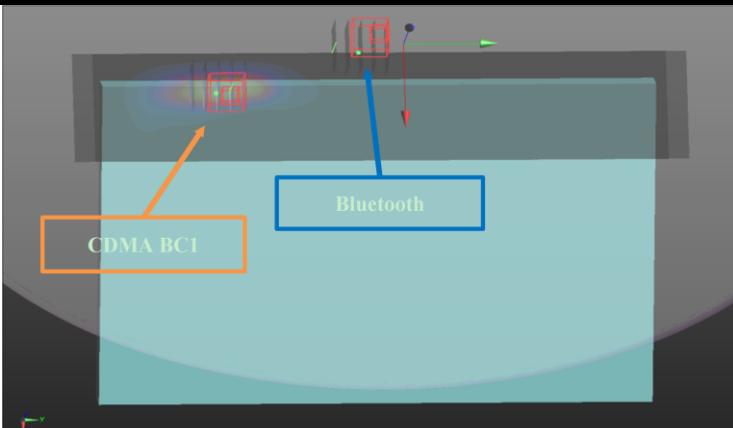

Conditions	Exposure Condition	Test Position	SAR Value (W/kg)	Coordinates			Peak Location Separation Distance (R _i , mm)	SPLSR	Simultaneous Transmission SAR Test
				x	y	z			
2.4G WALN Ch6	Body	Top-tilt Side	0.21	-4	153.2	6.13	186.0	0.00	SPLSR ≤ 0.04, Not required
Bluetooth Ch39			0	-40.7	-28.5	21.85			

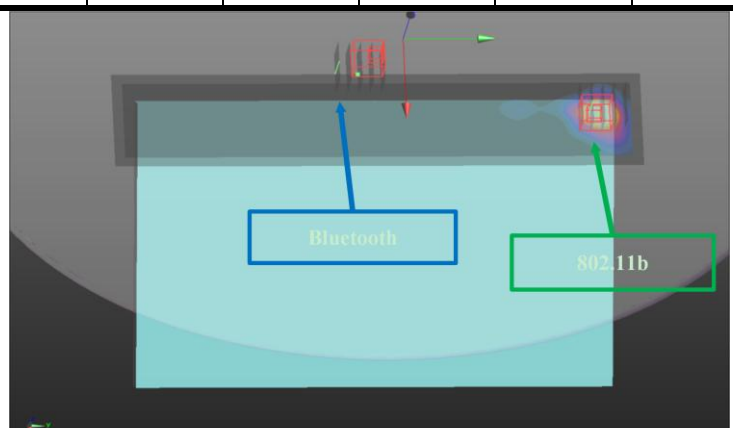

FCC SAR Test Report

Conditions	Exposure Condition	Test Position	SAR Value (W/kg)	Coordinates			Peak Location Separation Distance (R _i , mm)	SPLSR	Simultaneous Transmission SAR Test
				x	y	z			
CDMA BC1 Ch600	Body	Top-tilt	1.399	-6.8	-92	2.14	248.6	0.01	SPLSR ≤ 0.04, Not required
802.11ac VH80 CH155		Side	0.36	-0.5	156.5	3.3			

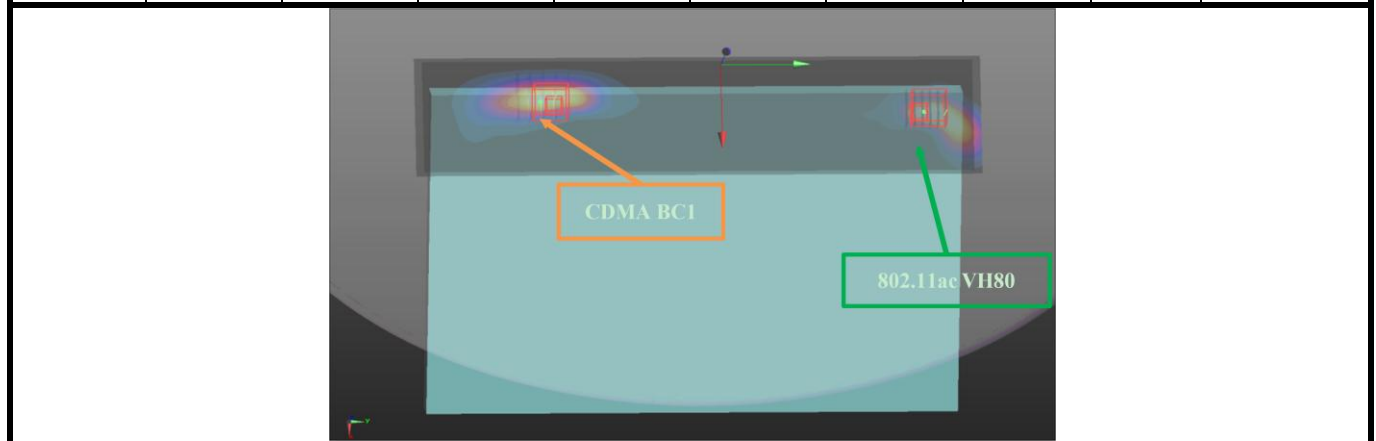

Conditions	Exposure Condition	Test Position	SAR Value (W/kg)	Coordinates			Peak Location Separation Distance (R _i , mm)	SPLSR	Simultaneous Transmission SAR Test
				x	y	z			
CDMA BC1 Ch600	Body	Top-tilt	1.399	-6.8	-92	2.14	74.6	0.02	SPLSR ≤ 0.04, Not required
Bluetooth Ch39		Side	0	-40.7	-28.5	21.85			

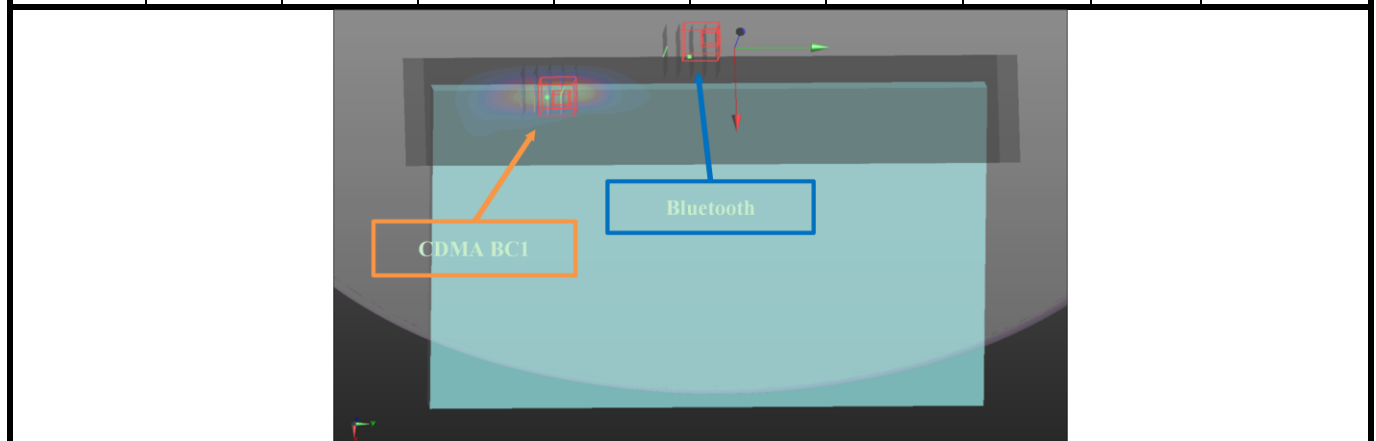

FCC SAR Test Report

Conditions	Exposure Condition	Test Position	SAR Value (W/kg)	Coordinates			Peak Location Separation Distance (R _i , mm)	SPLSR	Simultaneous Transmission SAR Test
				x	y	z			
802.11ac VH80 CH155	Body	Top-tilt Side	0.36	-0.5	156.5	3.3	190.2	0.00	SPLSR ≤ 0.04, Not required
Bluetooth Ch39			0	-40.7	-28.5	21.85			

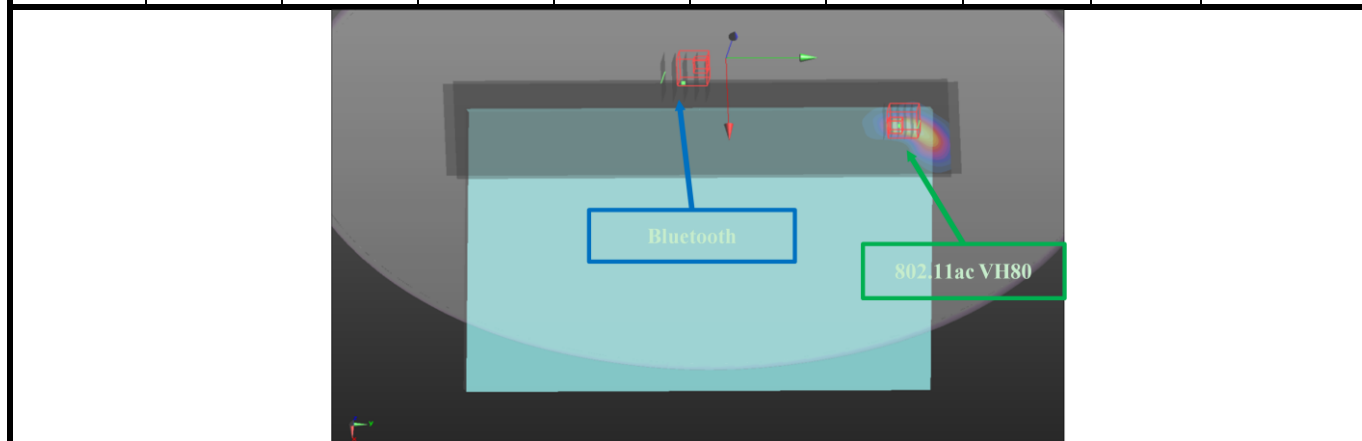

Conditions	Exposure Condition	Test Position	SAR Value (W/kg)	Coordinates			Peak Location Separation Distance (R _i , mm)	SPLSR	Simultaneous Transmission SAR Test
				x	y	z			
LTE 2 Ch18700	Body	Top-tilt Side	1.397	-5.2	-94.5	3.21	247.7	0.01	SPLSR ≤ 0.04, Not required
2.4G WALN Ch6			0.21	-4	153.2	6.13			

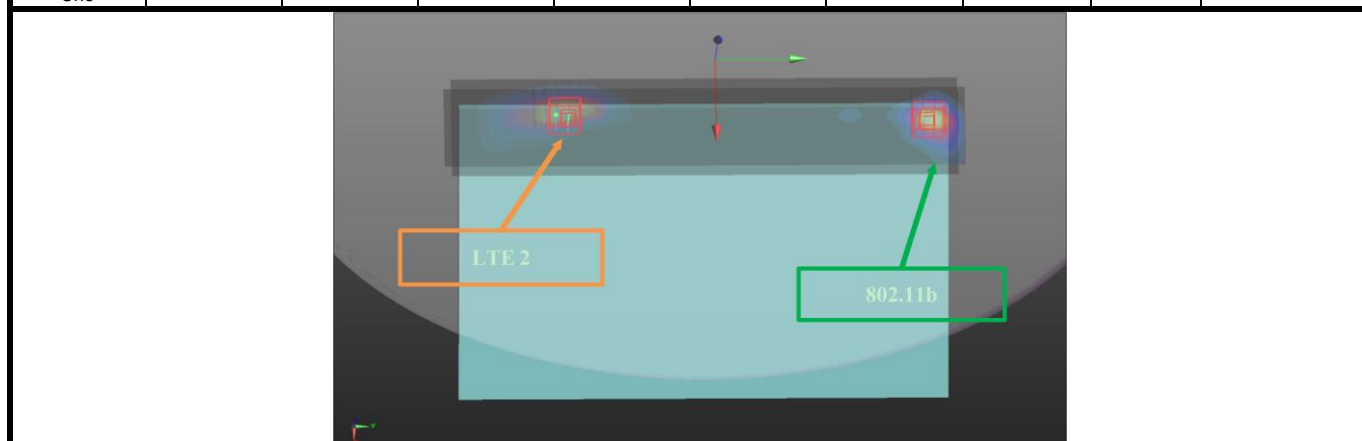

FCC SAR Test Report

Conditions	Exposure Condition	Test Position	SAR Value (W/kg)	Coordinates			Peak Location Separation Distance (R _i , mm)	SPLSR	Simultaneous Transmission SAR Test
				x	y	z			
LTE 2 Ch18700	Body	Top-tilt Side	1.397	-5.2	-94.5	3.21	77.2	0.02	SPLSR ≤ 0.04, Not required
Bluetooth Ch39			0	-40.7	-28.5	21.85			

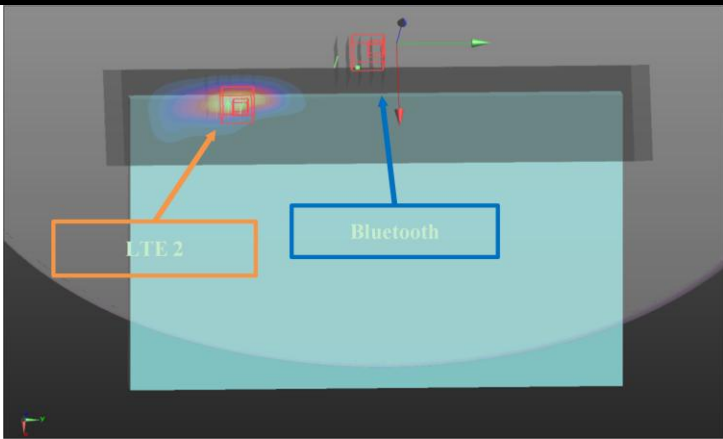

Conditions	Exposure Condition	Test Position	SAR Value (W/kg)	Coordinates			Peak Location Separation Distance (R _i , mm)	SPLSR	Simultaneous Transmission SAR Test
				x	y	z			
2.4G WALN Ch6	Body	Top-tilt Side	0.21	-4	153.2	6.13	186.0	0.00	SPLSR ≤ 0.04, Not required
Bluetooth Ch39			0	-40.7	-28.5	21.85			

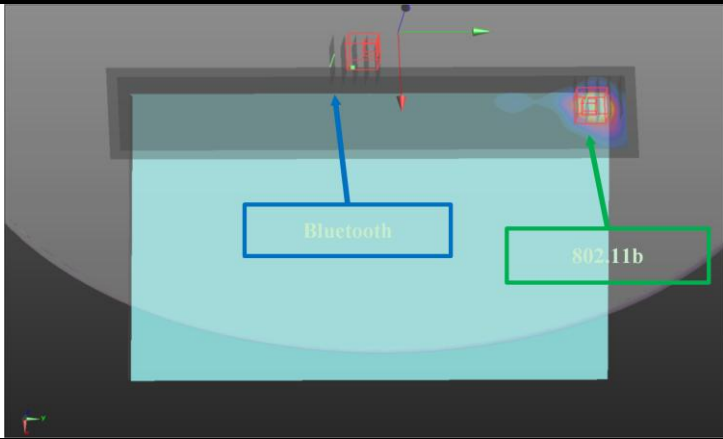

FCC SAR Test Report

Conditions	Exposure Condition	Test Position	SAR Value (W/kg)	Coordinates			Peak Location Separation Distance (R _i , mm)	SPLSR	Simultaneous Transmission SAR Test
				x	y	z			
LTE 2 Ch18700	Body	Top-tilt	1.397	-5.2	-94.5	3.21	251.0	0.01	SPLSR ≤ 0.04, Not required
802.11ac VH80 CH155		Side	0.36	-0.5	156.5	3.3			

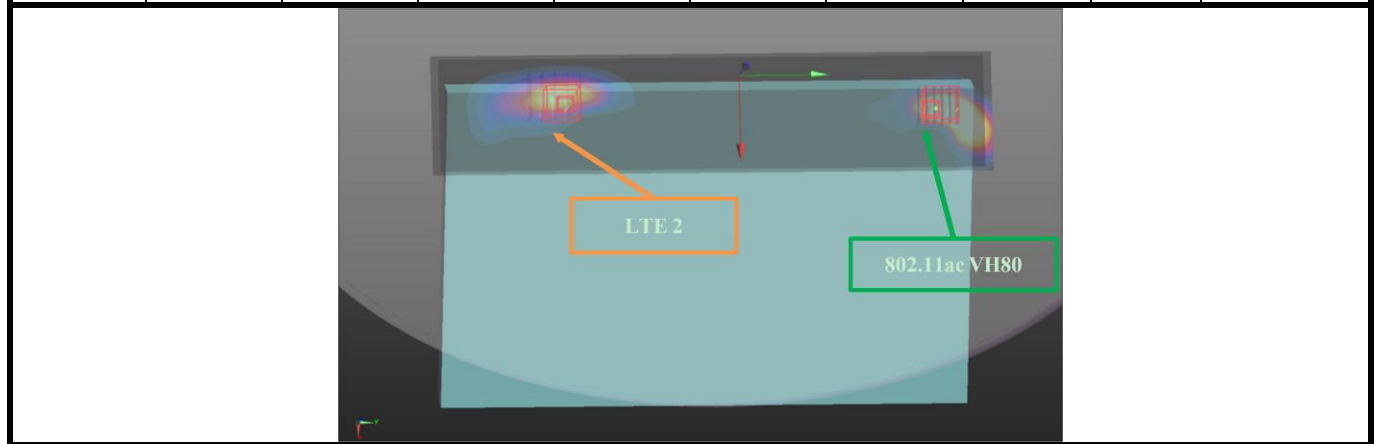

Conditions	Exposure Condition	Test Position	SAR Value (W/kg)	Coordinates			Peak Location Separation Distance (R _i , mm)	SPLSR	Simultaneous Transmission SAR Test
				x	y	z			
LTE 2 Ch18700	Body	Top-tilt	1.397	-5.2	-94.5	3.21	77.2	0.02	SPLSR ≤ 0.04, Not required
Bluetooth Ch39		Side	0	-40.7	-28.5	21.85			

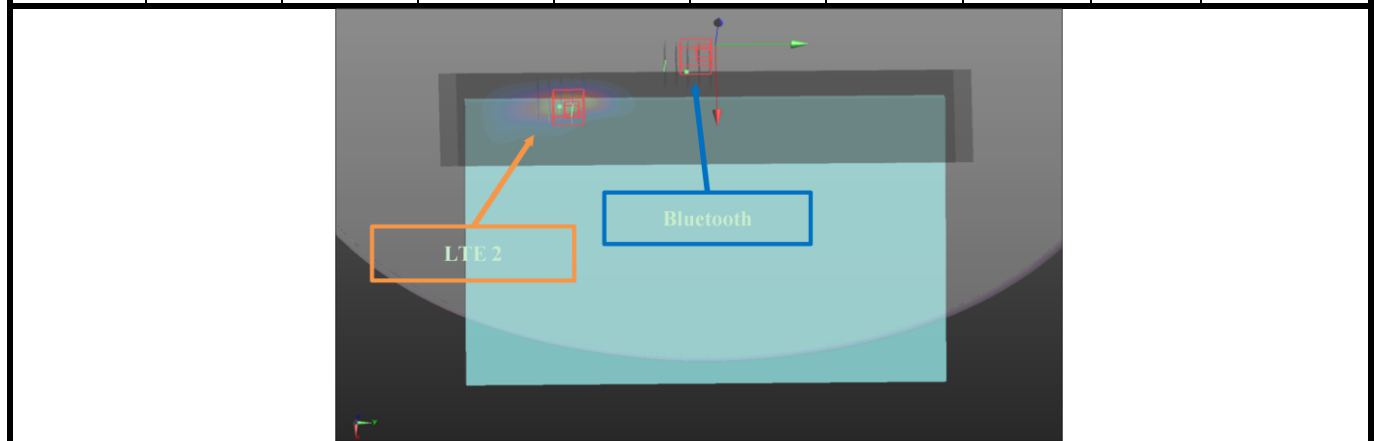

FCC SAR Test Report

Conditions	Exposure Condition	Test Position	SAR Value (W/kg)	Coordinates			Peak Location Separation Distance (R _i , mm)	SPLSR	Simultaneous Transmission SAR Test
				x	y	z			
802.11ac VH80 CH155	Body	Top-tilt Side	0.36	-0.5	156.5	3.3	190.2	0.00	SPLSR ≤ 0.04, Not required
Bluetooth Ch39			0	-40.7	-28.5	21.85			

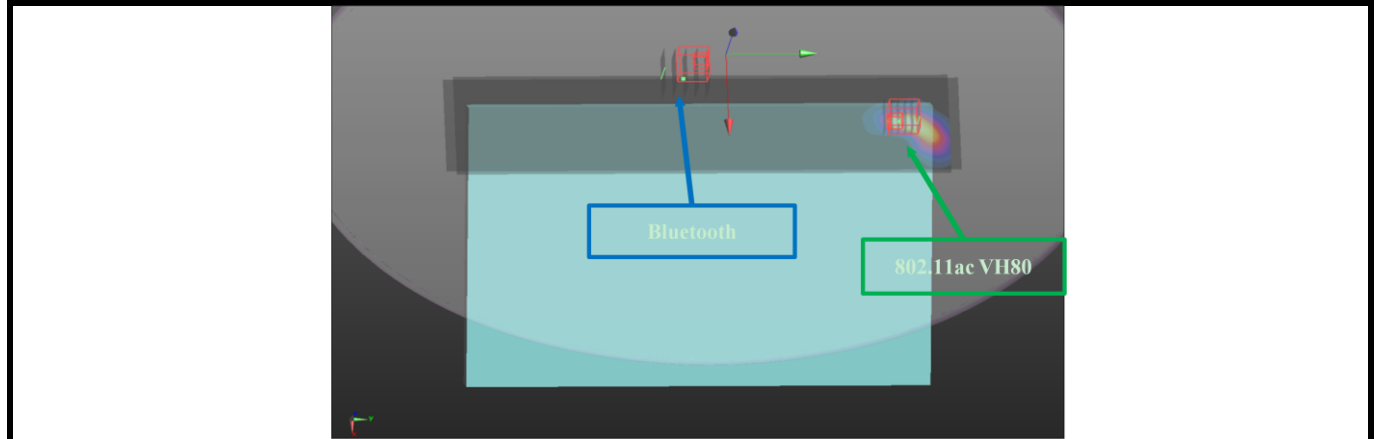

Conditions	Exposure Condition	Test Position	SAR Value (W/kg)	Coordinates			Peak Location Separation Distance (R _i , mm)	SPLSR	Simultaneous Transmission SAR Test
				x	y	z			
LTE 4 Ch20175	Body	Top Side	1.375	1.8	128.2	1.03	280.8	0.01	SPLSR ≤ 0.04, Not required
802.11ac VH80 CH155			0.35	5.5	-152.5	5.53			

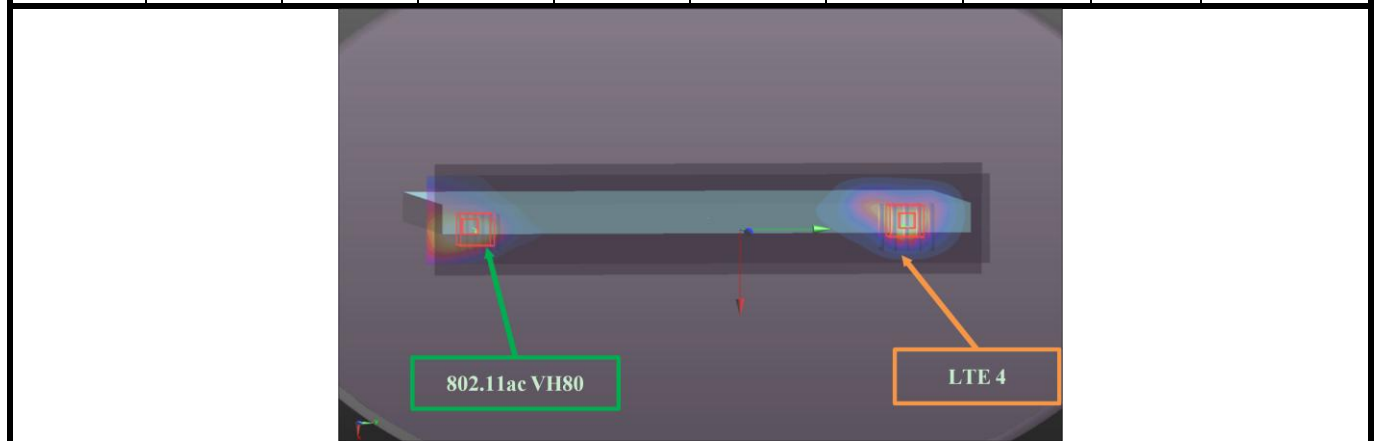

FCC SAR Test Report

Conditions	Exposure Condition	Test Position	SAR Value (W/kg)	Coordinates			Peak Location Separation Distance (R _i , mm)	SPLSR	Simultaneous Transmission SAR Test
				x	y	z			
LTE 4 Ch20175	Body	Top Side	1.375	1.8	128.2	1.03	272.2	0.01	SPLSR ≤ 0.04, Not required
Bluetooth Ch39			0	-9.3	-143.6	10.88			

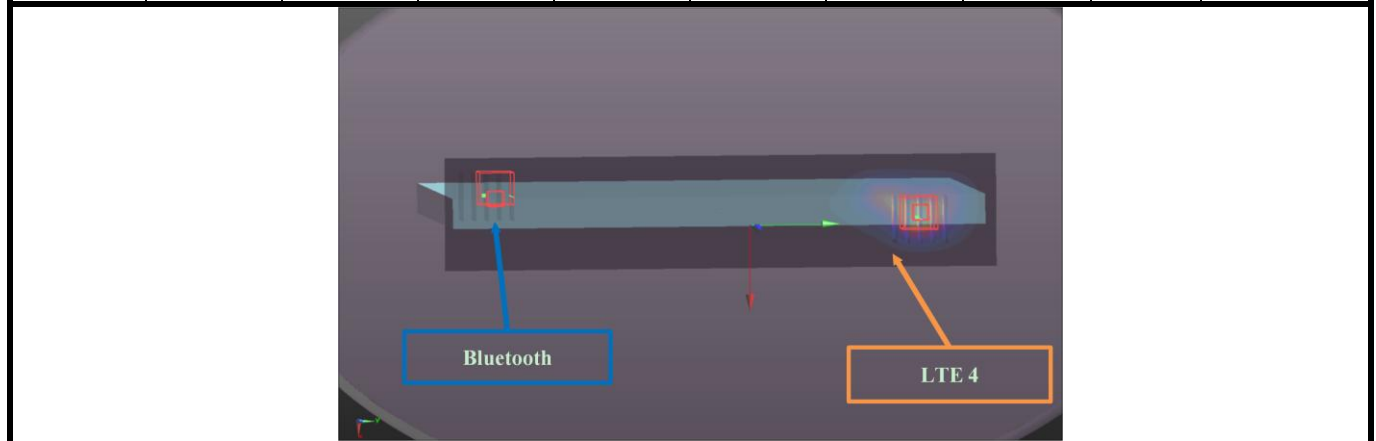

Conditions	Exposure Condition	Test Position	SAR Value (W/kg)	Coordinates			Peak Location Separation Distance (R _i , mm)	SPLSR	Simultaneous Transmission SAR Test
				x	y	z			
802.11ac VH80 CH155	Body	Top Side	0.35	5.5	-152.5	5.53	18.1	0.01	SPLSR ≤ 0.04, Not required
Bluetooth Ch39			0	-9.3	-143.6	10.88			

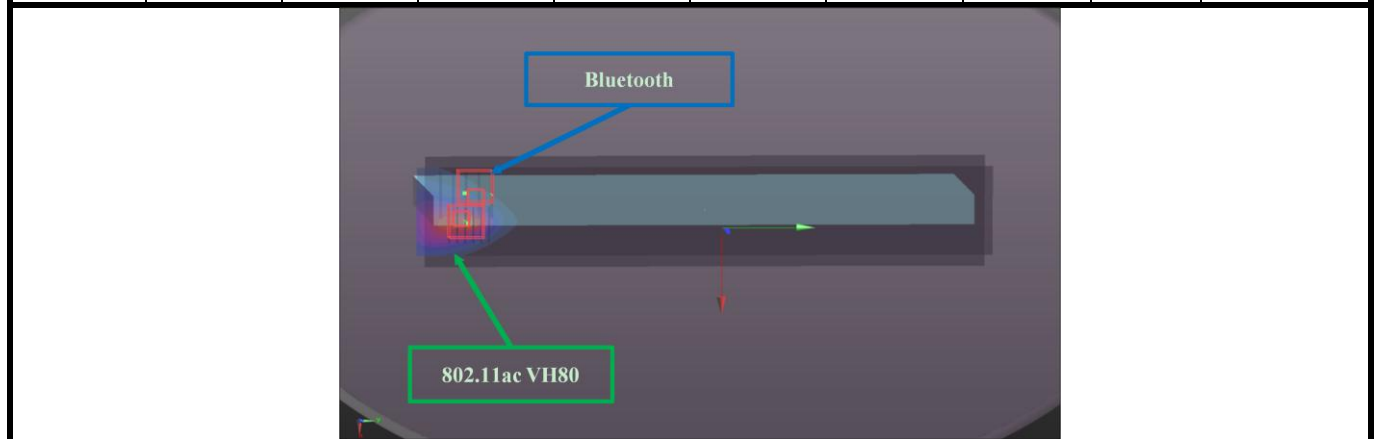

FCC SAR Test Report

Conditions	Exposure Condition	Test Position	SAR Value (W/kg)	Coordinates			Peak Location Separation Distance (R _i , mm)	SPLSR	Simultaneous Transmission SAR Test
				x	y	z			
LTE 13 Ch23230	Body	Top-tilt	1.245	-5.2	-107.3	2.05	263.8	0.01	SPLSR ≤ 0.04, Not required
802.11ac VH80 CH155		Side	0.36	-0.5	156.5	3.3			

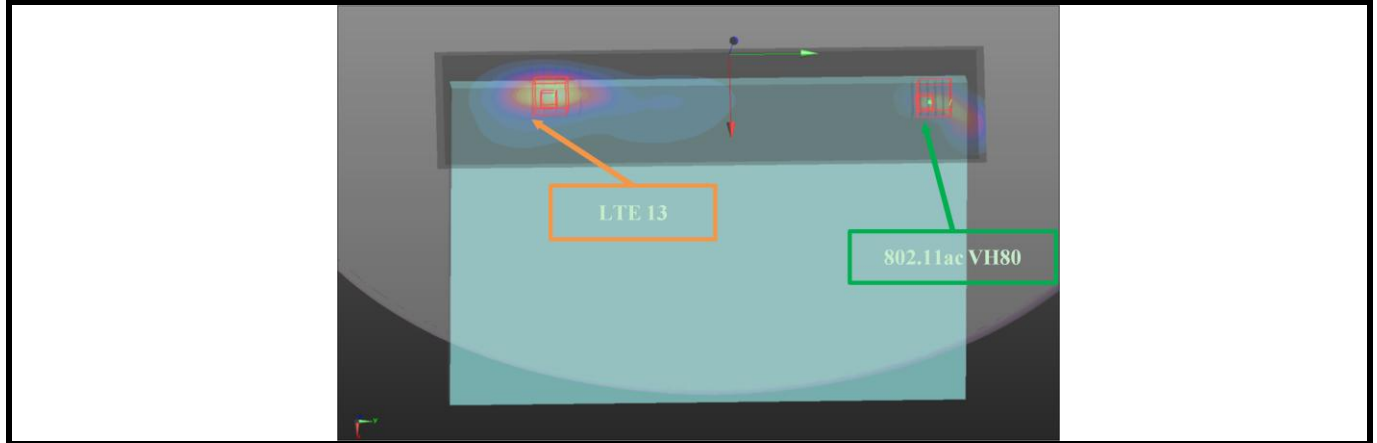

Conditions	Exposure Condition	Test Position	SAR Value (W/kg)	Coordinates			Peak Location Separation Distance (R _i , mm)	SPLSR	Simultaneous Transmission SAR Test
				x	y	z			
LTE 13 Ch23230	Body	Top-tilt	1.245	-5.2	-107.3	2.05	88.7	0.02	SPLSR ≤ 0.04, Not required
Bluetooth Ch39		Side	0	-40.7	-28.5	21.85			

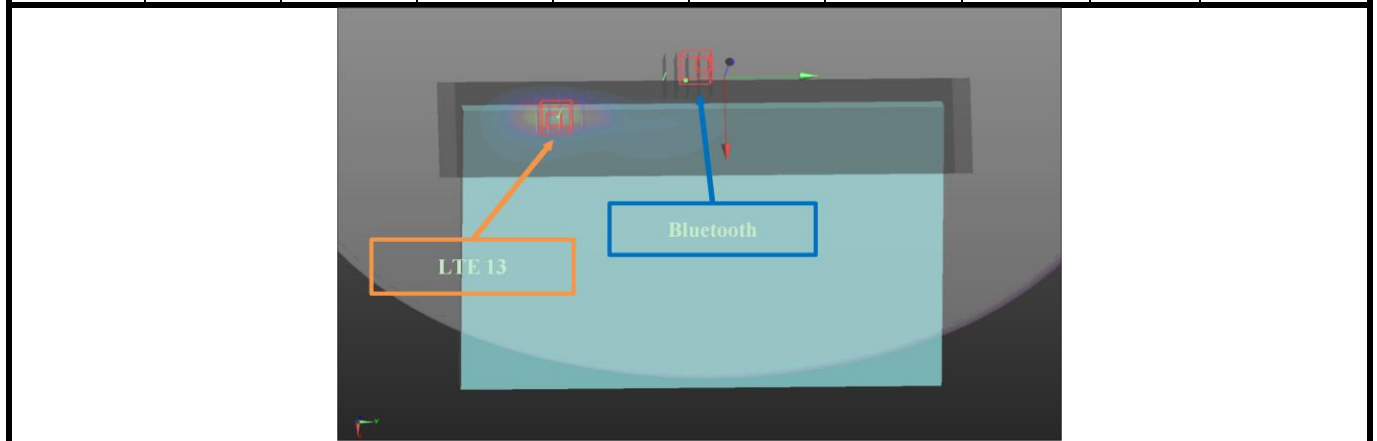

FCC SAR Test Report

Conditions	Exposure Condition	Test Position	SAR Value (W/kg)	Coordinates			Peak Location Separation Distance (R _i , mm)	SPLSR	Simultaneous Transmission SAR Test
				x	y	z			
802.11ac VH80 CH155	Body	Top-tilt Side	0.36	-0.5	156.5	3.3	190.2	0.00	SPLSR ≤ 0.04, Not required
Bluetooth Ch39			0	-40.7	-28.5	21.85			

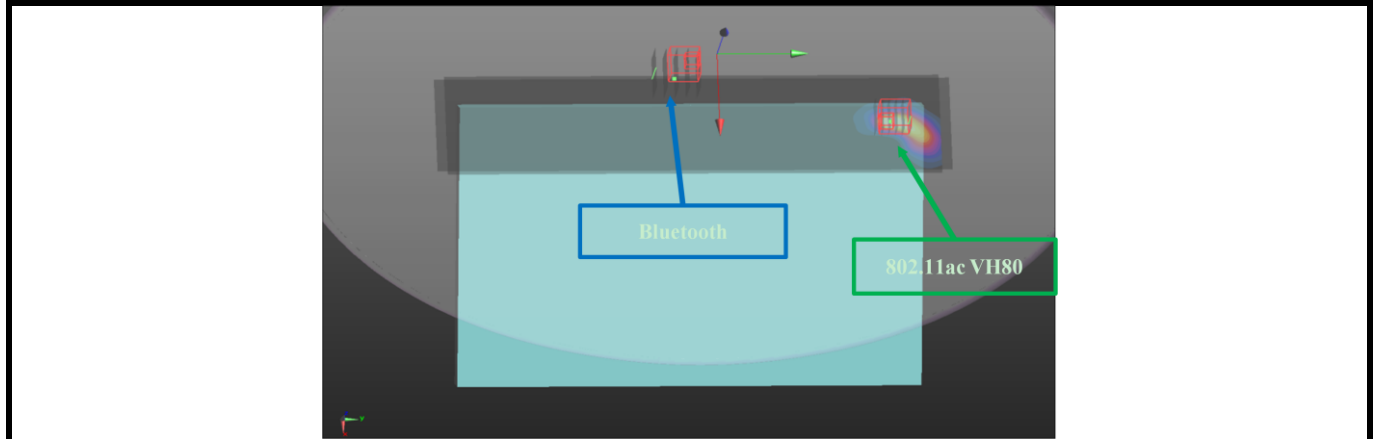

Conditions	Exposure Condition	Test Position	SAR Value (W/kg)	Coordinates			Peak Location Separation Distance (R _i , mm)	SPLSR	Simultaneous Transmission SAR Test
				x	y	z			
LTE 25 Ch26590	Body	Top Side	1.282	-5.2	96.1	1.2	248.9	0.01	SPLSR ≤ 0.04, Not required
802.11ac VH80 CH155			0.35	5.5	-152.5	5.53			

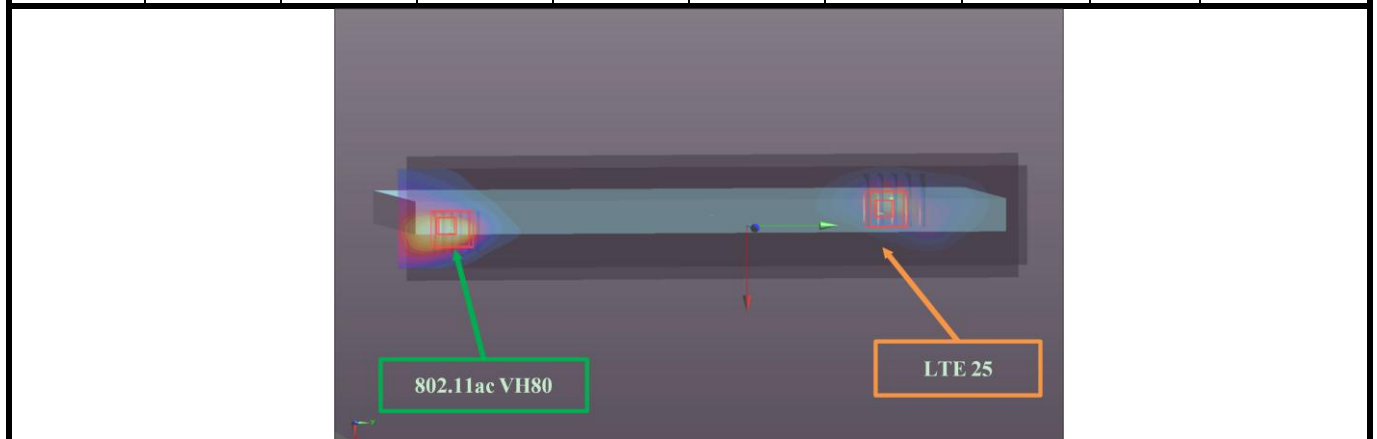

FCC SAR Test Report

Conditions	Exposure Condition	Test Position	SAR Value (W/kg)	Coordinates			Peak Location Separation Distance (R _i , mm)	SPLSR	Simultaneous Transmission SAR Test
				x	y	z			
LTE 25 Ch26590	Body	Top Side	1.282	-5.2	96.1	1.2	239.9	0.01	SPLSR ≤ 0.04, Not required
Bluetooth Ch39			0	-9.3	-143.6	10.88			

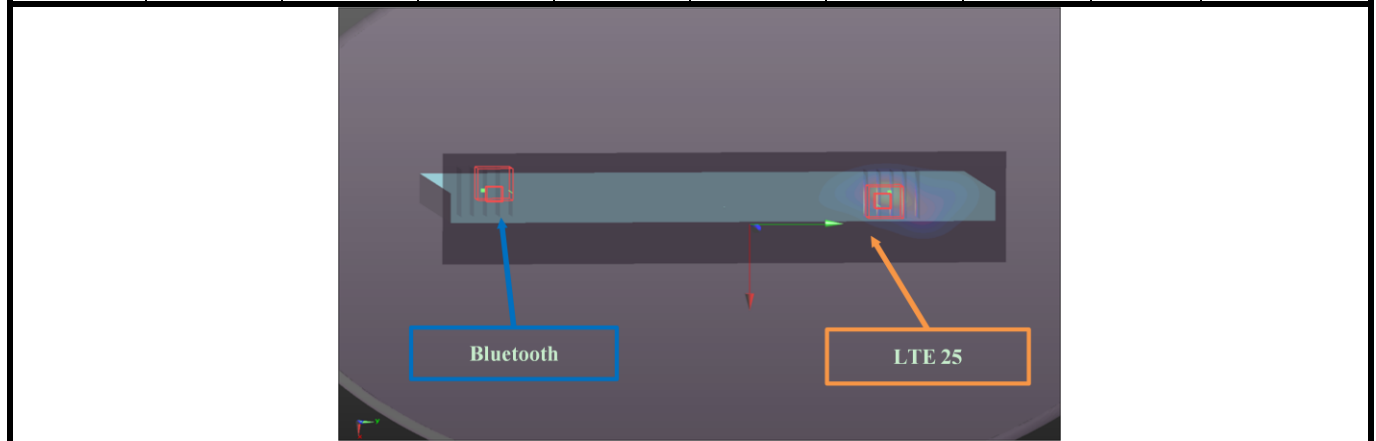

Conditions	Exposure Condition	Test Position	SAR Value (W/kg)	Coordinates			Peak Location Separation Distance (R _i , mm)	SPLSR	Simultaneous Transmission SAR Test
				x	y	z			
802.11ac VH80 CH155	Body	Top Side	0.35	5.5	-152.5	5.53	18.1	0.01	SPLSR ≤ 0.04, Not required
Bluetooth Ch39			0	-9.3	-143.6	10.88			

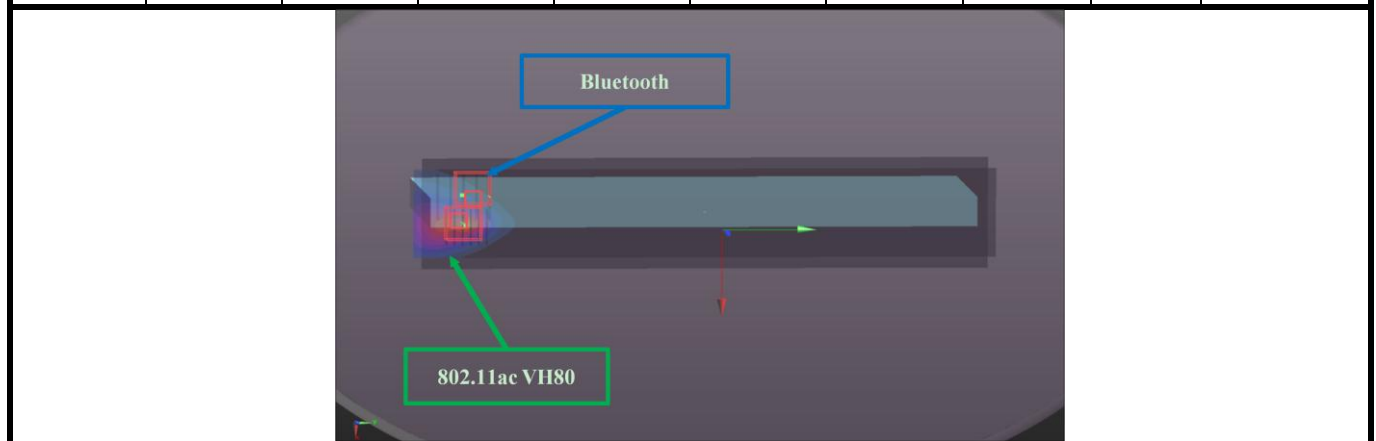

FCC SAR Test Report

Conditions	Exposure Condition	Test Position	SAR Value (W/kg)	Coordinates			Peak Location Separation Distance (R _i , mm)	SPLSR	Simultaneous Transmission SAR Test
				x	y	z			
LTE 25 Ch26365	Body	Top-tilt	1.316	-5.2	-94.5	3.29	251.0	0.01	SPLSR ≤ 0.04, Not required
802.11ac VH80 CH155		Side	0.36	-0.5	156.5	3.3			

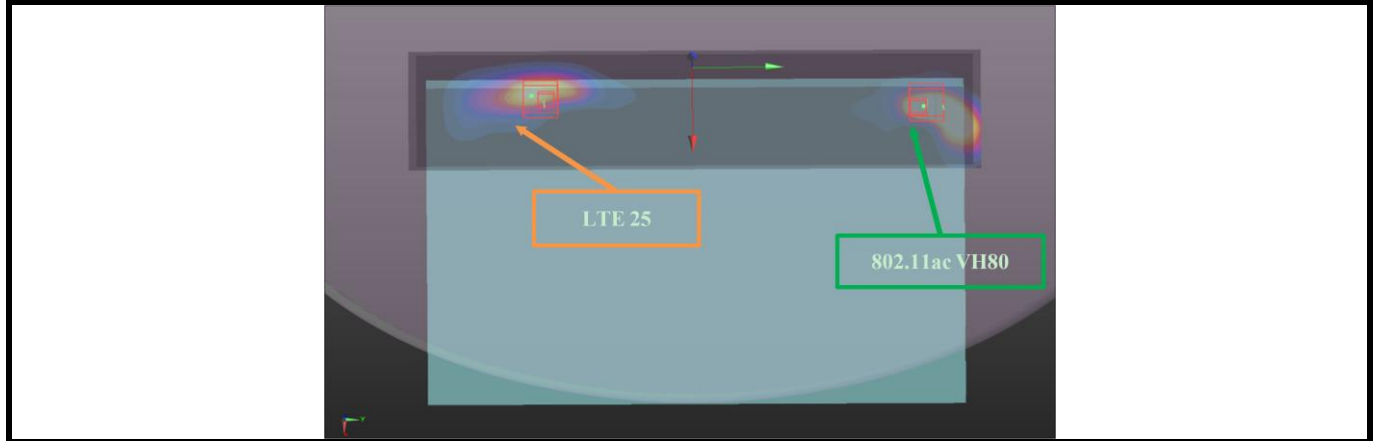

Conditions	Exposure Condition	Test Position	SAR Value (W/kg)	Coordinates			Peak Location Separation Distance (R _i , mm)	SPLSR	Simultaneous Transmission SAR Test
				x	y	z			
LTE 25 Ch26365	Body	Top-tilt	1.316	-5.2	-94.5	3.29	77.2	0.02	SPLSR ≤ 0.04, Not required
Bluetooth Ch39		Side	0	-40.7	-28.5	21.85			

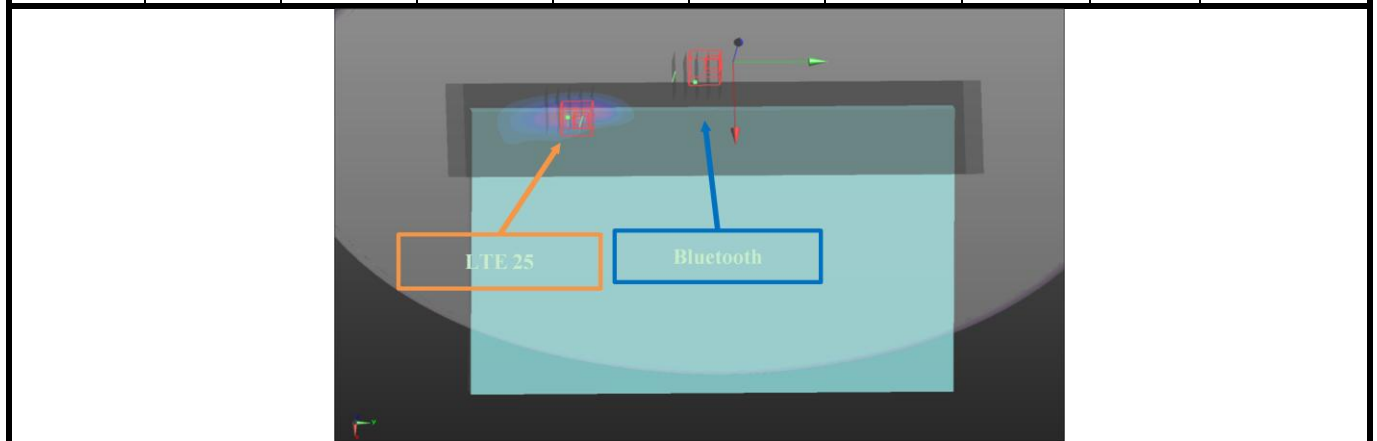

FCC SAR Test Report

Conditions	Exposure Condition	Test Position	SAR Value (W/kg)	Coordinates			Peak Location Separation Distance (R _i , mm)	SPLSR	Simultaneous Transmission SAR Test
				x	y	z			
802.11ac VH80 CH155	Body	Top-tilt Side	0.36	-0.5	156.5	3.3	190.2	0.00	SPLSR ≤ 0.04, Not required
Bluetooth Ch39			0	-40.7	-28.5	21.85			

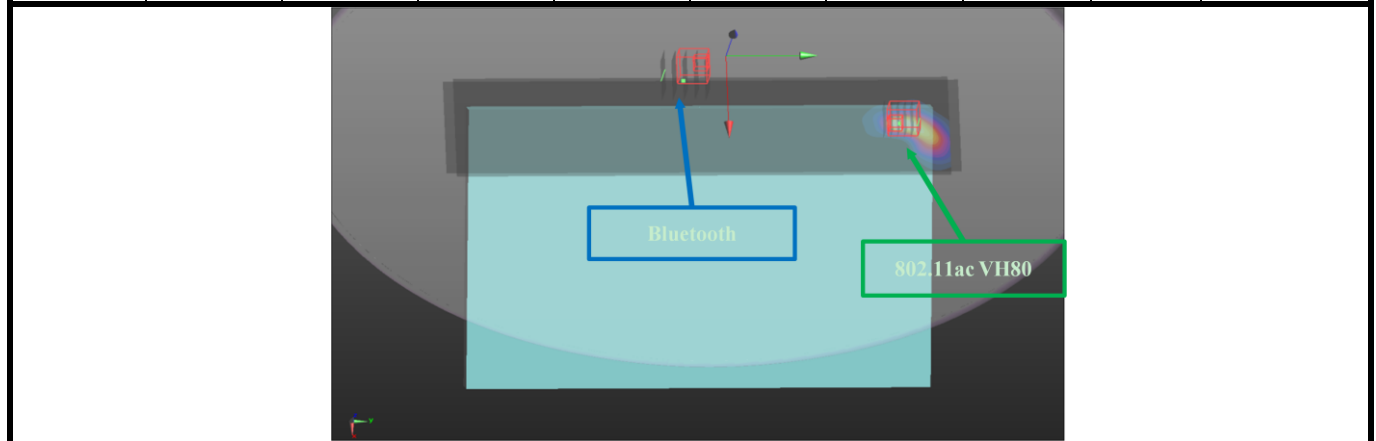

Test Engineer : Willy Chang, and Blake Wang

5. Calibration of Test Equipment

Equipment	Manufacturer	Model	SN	Cal. Date	Cal. Interval
System Validation Dipole	SPEAG	D2450V2	869	Jun. 21, 2016	1 Year
System Validation Dipole	SPEAG	D5GHzV2	1040	Jun. 17, 2016	1 Year
Dosimetric E-Field Probe	SPEAG	EX3DV4	3650	Jul. 25, 2016	1 Year
Dosimetric E-Field Probe	SPEAG	EX3DV4	3864	Jul. 25, 2016	1 Year
Data Acquisition Electronics	SPEAG	DAE4	861	Jun. 16, 2016	1 Year
Data Acquisition Electronics	SPEAG	DAE4	1431	Mar. 21, 2016	1 Year
Spectrum Analyzer	R&S	FSL6	102006	Mar. 25, 2016	1 Year
ENA Series Network Analyzer	Agilent	E5071C	MY46214281	Jun. 13, 2016	1 Year
MXG Analog Signal Generator	Agilent	N5181A	MY50143868	Jul. 07, 2016	1 Year
Vector Signal Generator	Anritsu	MG3710A	6201599977	Mar. 22, 2016	1 Year
Power Meter	Anritsu	ML2495A	1218009	Jul. 06, 2016	1 Year
Power Sensor	Anritsu	MA2411B	1207252	Jul. 06, 2016	1 Year
Thermometer	YFE	YF-160A	150601220	May 04, 2016	1 Year

6. Measurement Uncertainty

Source of Uncertainty	Tolerance (± %)	Probability Distribution	Divisor	Ci (1g)	Ci (10g)	Standard Uncertainty (± %, 1g)	Standard Uncertainty (± %, 10g)	Vi
Measurement System								
Probe Calibration	6.0	Normal	1	1	1	6.0	6.0	∞
Axial Isotropy	4.7	Rectangular	√3	0.707	0.707	1.9	1.9	∞
Hemispherical Isotropy	9.6	Rectangular	√3	0.707	0.707	3.9	3.9	∞
Boundary Effect	1.0	Rectangular	√3	1	1	0.6	0.6	∞
Linearity	4.7	Rectangular	√3	1	1	2.7	2.7	∞
System Detection Limits	0.25	Rectangular	√3	1	1	0.14	0.14	∞
Readout Electronics	0.3	Normal	1	1	1	0.3	0.3	∞
Response Time	0.0	Rectangular	√3	1	1	0.0	0.0	∞
Integration Time	1.7	Rectangular	√3	1	1	1.0	1.0	∞
RF Ambient Conditions - Noise	3.0	Rectangular	√3	1	1	1.7	1.7	∞
RF Ambient Conditions - Reflections	3.0	Rectangular	√3	1	1	1.7	1.7	∞
Probe Positioner Mechanical Tolerance	0.4	Rectangular	√3	1	1	0.2	0.2	∞
Probe Positioning with Respect to Phantom Shell	2.9	Rectangular	√3	1	1	1.7	1.7	∞
Extrapolation, interpolation, and integration algorithms for max. SAR evaluation	2.0	Rectangular	√3	1	1	1.2	1.2	∞
Test Sample Related								
Test Sample Positioning	1.5 / 0.7	Normal	1	1	1	1.5	0.7	32
Device Holder Uncertainty	4.2 / 1.8	Normal	1	1	1	4.2	1.8	32
Output Power Variation - SAR Drift Measurement	5.0	Rectangular	√3	1	1	2.9	2.9	∞
Phantom and Tissue Parameters								
Phantom Uncertainty (Shape and Thickness Tolerances)	7.2	Rectangular	√3	1	1	4.2	4.2	∞
Liquid Conductivity - Deviation from Target Values	5.0	Rectangular	√3	0.64	0.43	1.8	1.2	∞
Liquid Conductivity - Measurement Uncertainty	1.0	Normal	1	0.64	0.43	0.6	0.4	25
Liquid Permittivity - Deviation from Target Values	5.0	Rectangular	√3	0.60	0.49	1.7	1.4	∞
Liquid Permittivity - Measurement Uncertainty	0.5	Normal	1	0.60	0.49	0.3	0.2	25
Combined Standard Uncertainty						± 11.2 %	± 10.4 %	
Expanded Uncertainty (K=2)						± 22.4 %	± 20.8 %	

Uncertainty budget for frequency range 300 MHz to 3 GHz

FCC SAR Test Report

Source of Uncertainty	Tolerance (± %)	Probability Distribution	Divisor	C _i (1g)	C _i (10g)	Standard Uncertainty (± %, 1g)	Standard Uncertainty (± %, 10g)	V _i
Measurement System								
Probe Calibration	6.55	Normal	1	1	1	6.55	6.55	∞
Axial Isotropy	4.7	Rectangular	√3	0.707	0.707	1.9	1.9	∞
Hemispherical Isotropy	9.6	Rectangular	√3	0.707	0.707	3.9	3.9	∞
Boundary Effect	2.0	Rectangular	√3	1	1	1.2	1.2	∞
Linearity	4.7	Rectangular	√3	1	1	2.7	2.7	∞
System Detection Limits	0.25	Rectangular	√3	1	1	0.14	0.14	∞
Readout Electronics	0.3	Normal	1	1	1	0.3	0.3	∞
Response Time	0.0	Rectangular	√3	1	1	0.0	0.0	∞
Integration Time	1.7	Rectangular	√3	1	1	1.0	1.0	∞
RF Ambient Conditions - Noise	3.0	Rectangular	√3	1	1	1.7	1.7	∞
RF Ambient Conditions - Reflections	3.0	Rectangular	√3	1	1	1.7	1.7	∞
Probe Positioner Mechanical Tolerance	0.4	Rectangular	√3	1	1	0.2	0.2	∞
Probe Positioning with Respect to Phantom Shell	6.7	Rectangular	√3	1	1	3.9	3.9	∞
Extrapolation, interpolation, and integration algorithms for max. SAR evaluation	4.0	Rectangular	√3	1	1	2.3	2.3	∞
Test Sample Related								
Test Sample Positioning	1.5 / 0.7	Normal	1	1	1	1.5	0.7	32
Device Holder Uncertainty	4.2 / 1.8	Normal	1	1	1	4.2	1.8	32
Output Power Variation - SAR Drift Measurement	5.0	Rectangular	√3	1	1	2.9	2.9	∞
Phantom and Tissue Parameters								
Phantom Uncertainty (Shape and Thickness Tolerances)	7.6	Rectangular	√3	1	1	4.4	4.4	∞
Liquid Conductivity - Deviation from Target Values	5.0	Rectangular	√3	0.64	0.43	1.8	1.2	∞
Liquid Conductivity - Measurement Uncertainty	1.0	Normal	1	0.64	0.43	0.6	0.4	25
Liquid Permittivity - Deviation from Target Values	5.0	Rectangular	√3	0.60	0.49	1.7	1.4	∞
Liquid Permittivity - Measurement Uncertainty	0.5	Normal	1	0.60	0.49	0.3	0.2	25
Combined Standard Uncertainty						± 12.3 %	± 11.5 %	
Expanded Uncertainty (K=2)						± 24.6 %	± 23.0 %	

Uncertainty budget for frequency range 3 GHz to 6 GHz

7. Information on the Testing Laboratories

We, Bureau Veritas Consumer Products Services (H.K.) Ltd., Taoyuan Branch, were founded in 1988 to provide our best service in EMC, Radio, Telecom and Safety consultation. Our laboratories are accredited and approved according to ISO/IEC 17025.

If you have any comments, please feel free to contact us at the following:

Taiwan HwaYa EMC/RF/Safety/Telecom Lab:

Add: No. 19, Hwa Ya 2nd Rd, Wen Hwa Vil., Kwei Shan Hsiang, Taoyuan Hsien 333, Taiwan, R.O.C.

Tel: 886-3-318-3232

Fax: 886-3-327-0892

Taiwan LinKo EMC/RF Lab:

Add: No. 47-2, 14th Ling, Chia Pau Vil., Linkou Dist., New Taipei City 244, Taiwan, R.O.C.

Tel: 886-2-2605-2180

Fax: 886-2-2605-1924

Taiwan HsinChu EMC/RF Lab:

Add: No. 81-1, Lu Liao Keng, 9th Ling, Wu Lung Vil., Chiung Lin Township, Hsinchu County 307, Taiwan, R.O.C.

Tel: 886-3-593-5343

Fax: 886-3-593-5342

Email: service.adt@tw.bureauveritas.com

Web Site: www.adt.com.tw

The road map of all our labs can be found in our web site also.

---END---



Appendix A. SAR Plots of System Verification

The plots for system verification with largest deviation for each SAR system combination are shown as follows.

System Check_B2450_161008

DUT: Dipole 2450 MHz; Type: D2450V2; SN: 869

Communication System: CW; Frequency: 2450 MHz; Duty Cycle: 1:1

Medium: B19T27N3_1008 Medium parameters used: $f = 2450$ MHz; $\sigma = 1.997$ S/m; $\epsilon_r = 52.222$; $\rho = 1000$ kg/m³

Ambient Temperature : 23.8 °C ; Liquid Temperature : 23.3 °C

DASY5 Configuration:

- Probe: EX3DV4 - SN3650; ConvF(7.36, 7.36, 7.36); Calibrated: 2016/07/25;
- Sensor-Surface: 1.4mm (Mechanical Surface Detection)
- Electronics: DAE4 Sn861; Calibrated: 2016/06/16
- Phantom: ELI Phantom_1204; Type: QDOVA;
- Measurement SW: DASY52, Version 52.8 (8); SEMCAD X Version 14.6.10 (7373)

Pin=250mW/Area Scan (81x81x1): Interpolated grid: dx=1.200 mm, dy=1.200 mm
Maximum value of SAR (interpolated) = 19.4 W/kg

Pin=250mW/Zoom Scan (7x7x7)/Cube 0: Measurement grid: dx=5mm, dy=5mm, dz=5mm
Reference Value = 92.67 V/m; Power Drift = -0.05 dB
Peak SAR (extrapolated) = 24.5 W/kg
SAR(1 g) = 12 W/kg; SAR(10 g) = 5.55 W/kg
Maximum value of SAR (measured) = 20.0 W/kg

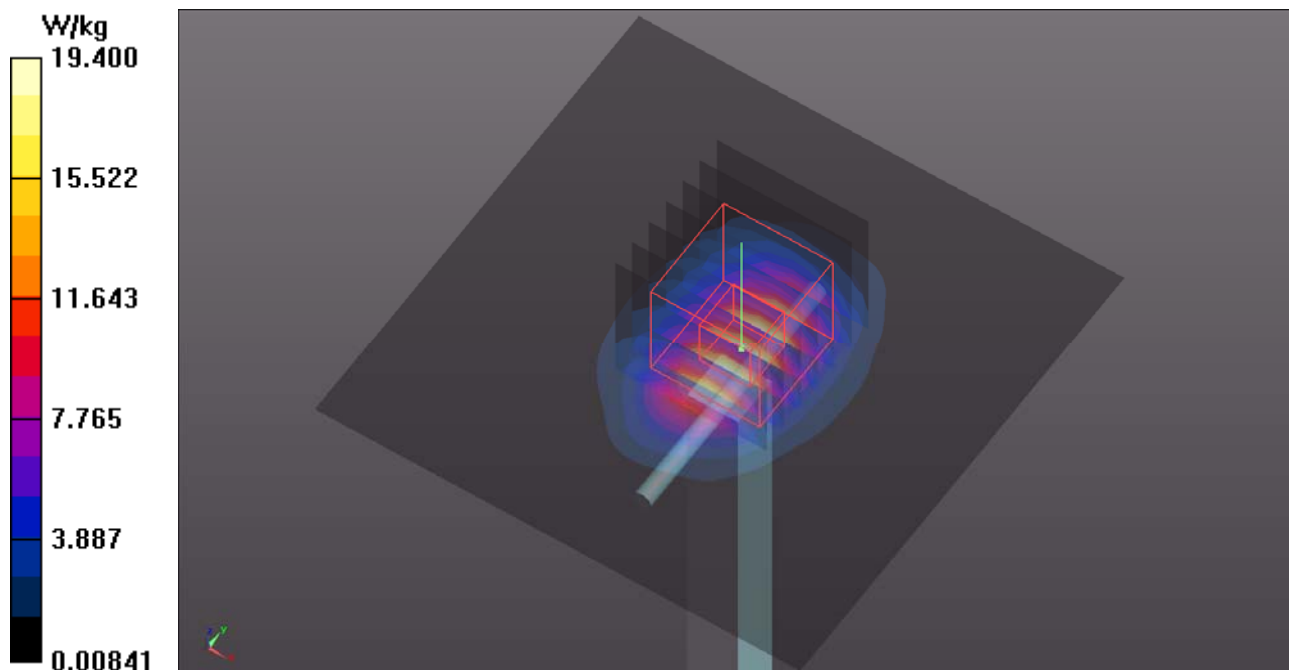

System Check_B5300_161011

DUT: Dipole 5 GHz; Type: D5GHzV2; SN: 1040

Communication System: CW; Frequency: 5300 MHz; Duty Cycle: 1:1

Medium: B34T60N3_1011 Medium parameters used: $f = 5300$ MHz; $\sigma = 5.531$ S/m; $\epsilon_r = 47.111$; $\rho = 1000$ kg/m³

Ambient Temperature : 23.8 °C ; Liquid Temperature : 23.1 °C

DASY5 Configuration:

- Probe: EX3DV4 - SN3650; ConvF(4.75, 4.75, 4.75); Calibrated: 2016/07/25;
- Sensor-Surface: 1.4mm (Mechanical Surface Detection)
- Electronics: DAE4 Sn861; Calibrated: 2016/06/16
- Phantom: ELI Phantom_1204; Type: QDOVA;
- Measurement SW: DASY52, Version 52.8 (8); SEMCAD X Version 14.6.10 (7373)

Pin=100mW/Area Scan (91x91x1): Interpolated grid: dx=1.000 mm, dy=1.000 mm
Maximum value of SAR (interpolated) = 17.4 W/kg

Pin=100mW/Zoom Scan (7x7x12)/Cube 0: Measurement grid: dx=4mm, dy=4mm, dz=2mm
Reference Value = 61.07 V/m; Power Drift = -0.13 dB
Peak SAR (extrapolated) = 29.9 W/kg
SAR(1 g) = 7.73 W/kg; SAR(10 g) = 2.23 W/kg
Maximum value of SAR (measured) = 19.3 W/kg

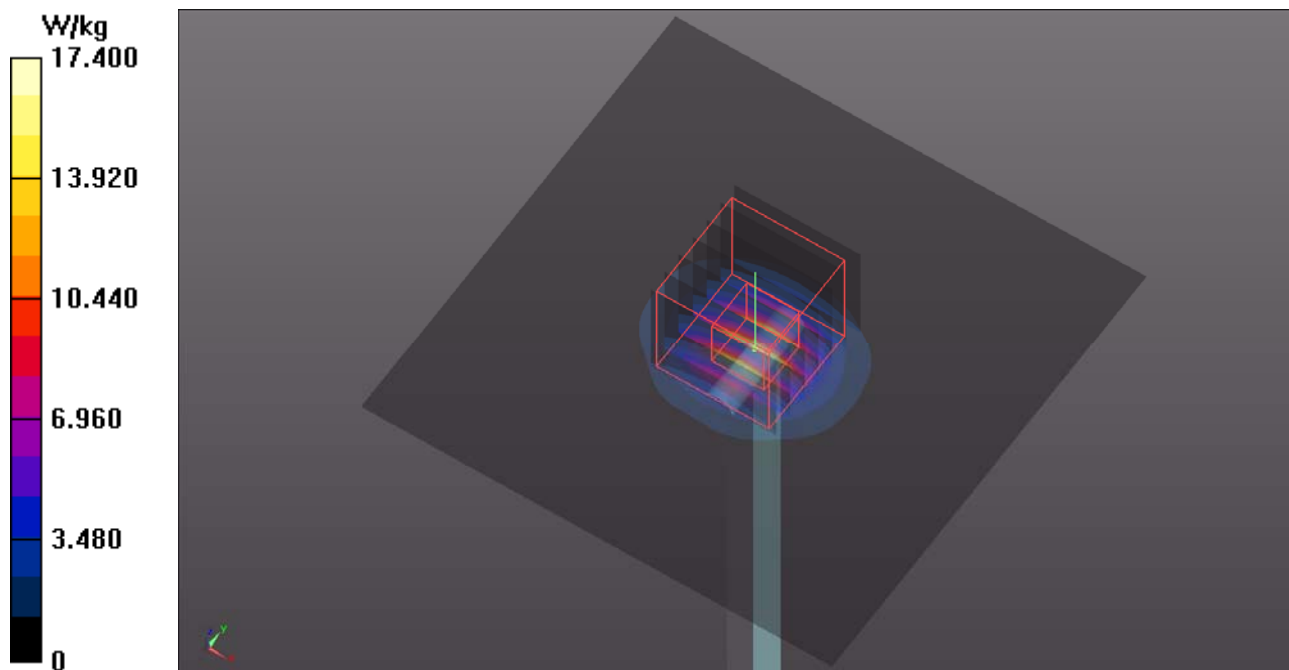

System Check_B5600_161012

DUT: Dipole 5 GHz; Type: D5GHzV2; SN: 1040

Communication System: CW; Frequency: 5600 MHz; Duty Cycle: 1:1

Medium: B34T60N3_1012 Medium parameters used: $f = 5600$ MHz; $\sigma = 5.93$ S/m; $\epsilon_r = 46.622$; $\rho = 1000$ kg/m³

Ambient Temperature : 23.8 °C ; Liquid Temperature : 23.2 °C

DASY5 Configuration:

- Probe: EX3DV4 - SN3650; ConvF(4.01, 4.01, 4.01); Calibrated: 2016/07/25;
- Sensor-Surface: 1.4mm (Mechanical Surface Detection)
- Electronics: DAE4 Sn861; Calibrated: 2016/06/16
- Phantom: ELI Phantom_1204; Type: QDOVA;
- Measurement SW: DASY52, Version 52.8 (8); SEMCAD X Version 14.6.10 (7373)

Pin=100mW/Area Scan (91x91x1): Interpolated grid: dx=1.000 mm, dy=1.000 mm
Maximum value of SAR (interpolated) = 18.2 W/kg

Pin=100mW/Zoom Scan (7x7x12)/Cube 0: Measurement grid: dx=4mm, dy=4mm, dz=2mm
Reference Value = 59.91 V/m; Power Drift = -0.03 dB
Peak SAR (extrapolated) = 29.5 W/kg
SAR(1 g) = 7.7 W/kg; SAR(10 g) = 2.18 W/kg
Maximum value of SAR (measured) = 19.1 W/kg

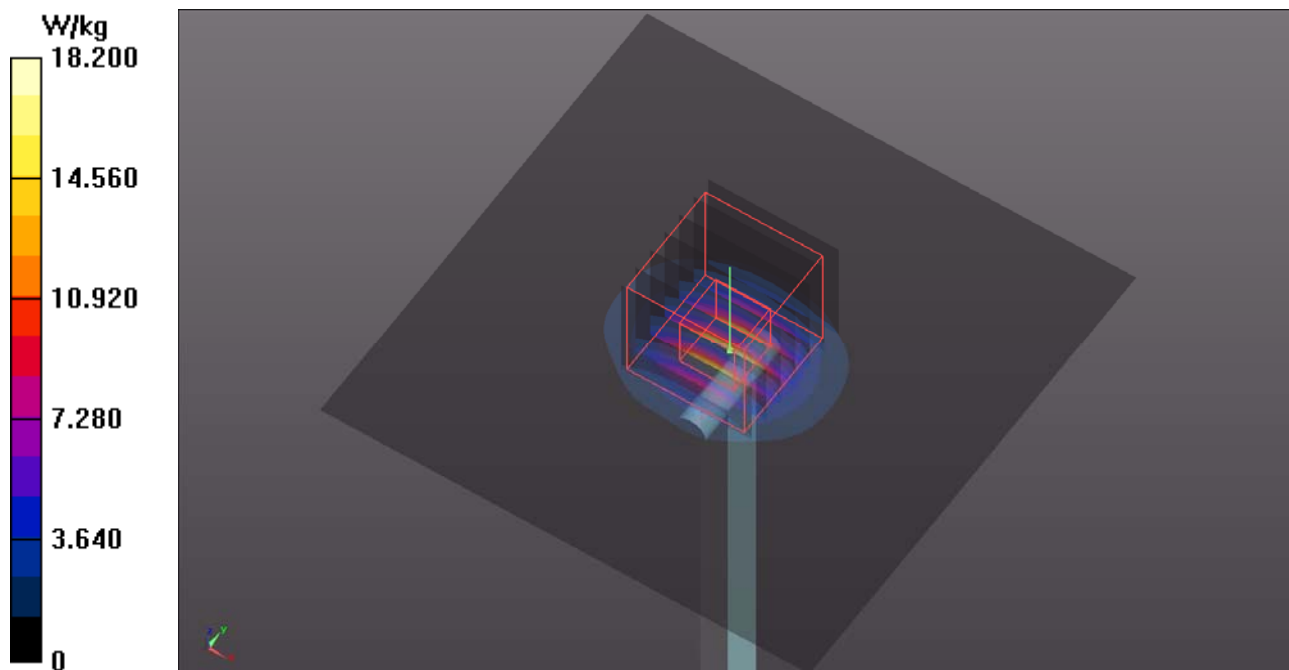

System Check_B5800_161007

DUT: Dipole 5 GHz; Type: D5GHzV2; SN: 1040

Communication System: CW; Frequency: 5800 MHz; Duty Cycle: 1:1

Medium: B34T60N3_1007 Medium parameters used: $f = 5800$ MHz; $\sigma = 6.203$ S/m; $\epsilon_r = 46.259$; $\rho = 1000$ kg/m³

Ambient Temperature : 23.6 °C ; Liquid Temperature : 23.2 °C

DASY5 Configuration:

- Probe: EX3DV4 - SN3650; ConvF(4.36, 4.36, 4.36); Calibrated: 2016/07/25;
- Sensor-Surface: 1.4mm (Mechanical Surface Detection)
- Electronics: DAE4 Sn861; Calibrated: 2016/06/16
- Phantom: ELI Phantom_1204; Type: QDOVA;
- Measurement SW: DASY52, Version 52.8 (8); SEMCAD X Version 14.6.10 (7373)

Pin=100mW/Area Scan (91x91x1): Interpolated grid: dx=1.000 mm, dy=1.000 mm
Maximum value of SAR (interpolated) = 19.1 W/kg

Pin=100mW/Zoom Scan (7x7x12)/Cube 0: Measurement grid: dx=4mm, dy=4mm, dz=2mm
Reference Value = 59.54 V/m; Power Drift = -0.08 dB
Peak SAR (extrapolated) = 33.2 W/kg
SAR(1 g) = 7.98 W/kg; SAR(10 g) = 2.26 W/kg
Maximum value of SAR (measured) = 20.9 W/kg

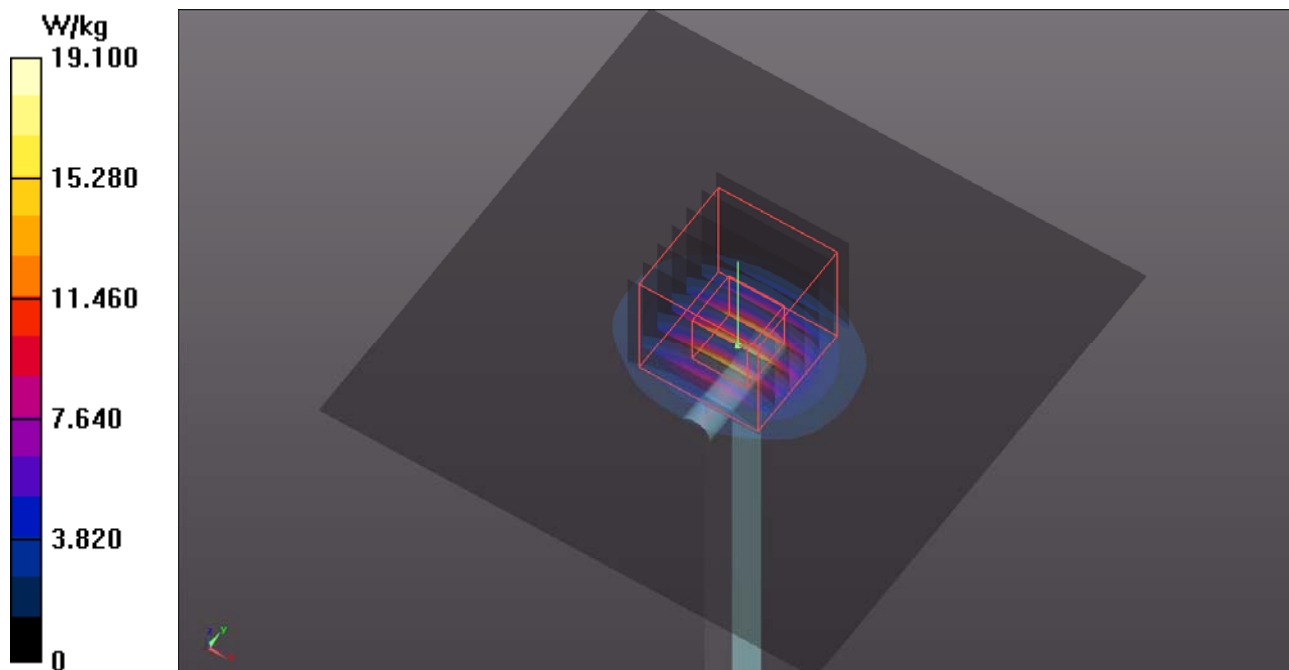

Appendix B. SAR Plots of SAR Measurement

The SAR plots for highest measured SAR in each exposure configuration, wireless mode and frequency band combination, and measured SAR > 1.5 W/kg are shown as follows.

P01 2.4G WLAN_802.11b_Left-tilt Side_0cm_Ch6_Ant0

DUT: 160922C07

Communication System: WLAN_2.4G; Frequency: 2437 MHz; Duty Cycle: 1:1

Medium: B19T27N3_1008 Medium parameters used: $f = 2437$ MHz; $\sigma = 1.983$ S/m; $\epsilon_r = 52.249$; $\rho = 1000$ kg/m³

Ambient Temperature : 23.8 °C ; Liquid Temperature : 23.3 °C

DASY5 Configuration:

- Probe: EX3DV4 - SN3650; ConvF(7.36, 7.36, 7.36); Calibrated: 2016/07/25;
- Sensor-Surface: 1.4mm (Mechanical Surface Detection)
- Electronics: DAE4 Sn861; Calibrated: 2016/06/16
- Phantom: ELI Phantom_1204; Type: QDOVA;
- Measurement SW: DASY52, Version 52.8 (8); SEMCAD X Version 14.6.10 (7373)

- **Area Scan (51x221x1):** Interpolated grid: dx=1.200 mm, dy=1.200 mm

Maximum value of SAR (interpolated) = 0.593 W/kg

- **Zoom Scan (5x5x7)/Cube 0:** Measurement grid: dx=8mm, dy=8mm, dz=5mm

Reference Value = 3.737 V/m; Power Drift = 0.07 dB

Peak SAR (extrapolated) = 1.17 W/kg

SAR(1 g) = 0.534 W/kg; SAR(10 g) = 0.251 W/kg

Maximum value of SAR (measured) = 0.920 W/kg

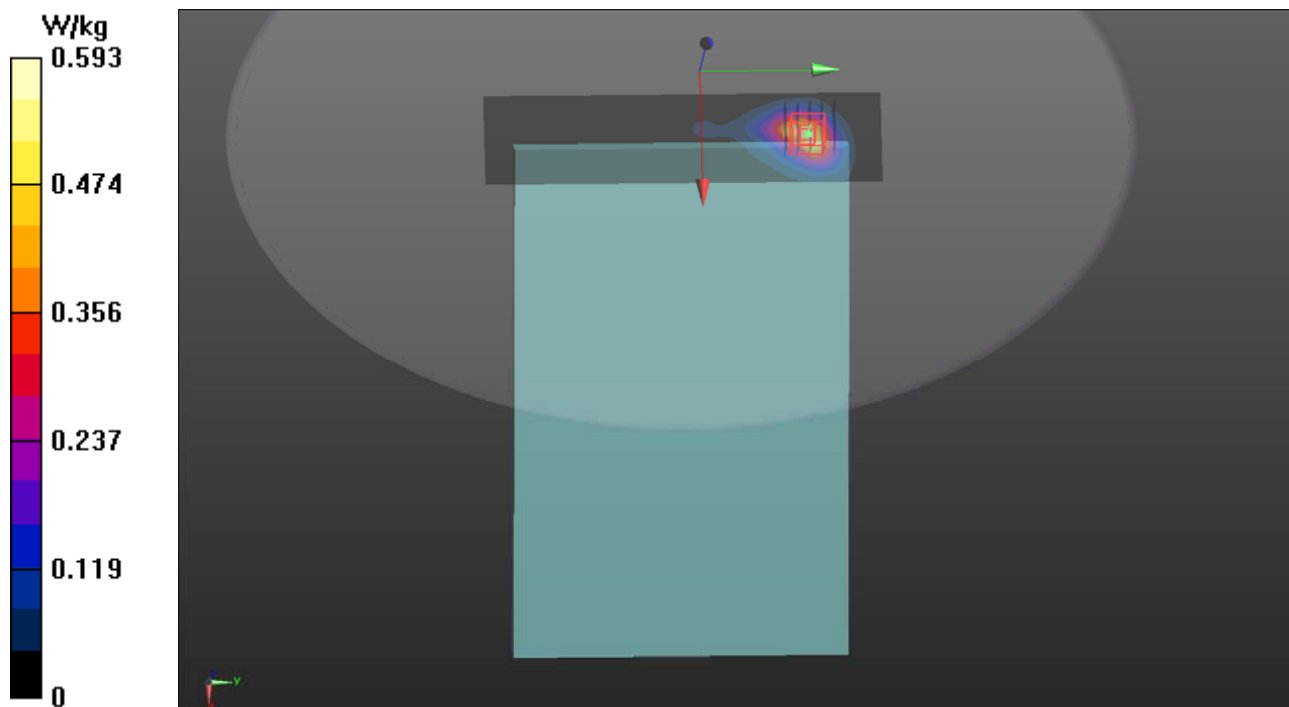

P02 5.3G WLAN_802.11ac VH80_Left Side_0cm_Ch58_Ant0

DUT: 160922C07

Communication System: WLAN_5G; Frequency: 5290 MHz; Duty Cycle: 1:1

Medium: B34T60N3_1011 Medium parameters used: $f = 5290$ MHz; $\sigma = 5.517$ S/m; $\epsilon_r = 47.136$; $\rho = 1000$ kg/m³

Ambient Temperature : 23.8 °C ; Liquid Temperature : 23.1 °C

DASY5 Configuration:

- Probe: EX3DV4 - SN3650; ConvF(4.75, 4.75, 4.75); Calibrated: 2016/07/25;
- Sensor-Surface: 1.4mm (Mechanical Surface Detection)
- Electronics: DAE4 Sn861; Calibrated: 2016/06/16
- Phantom: ELI Phantom_1204; Type: QDOVA;
- Measurement SW: DASY52, Version 52.8 (8); SEMCAD X Version 14.6.10 (7373)

- **Area Scan (101x251x1):** Interpolated grid: dx=1.000 mm, dy=1.000 mm

Maximum value of SAR (interpolated) = 1.82 W/kg

- **Zoom Scan (6x6x12)/Cube 0:** Measurement grid: dx=5mm, dy=5mm, dz=2mm

Reference Value = 3.964 V/m; Power Drift = -0.15 dB

Peak SAR (extrapolated) = 3.20 W/kg

SAR(1 g) = 0.846 W/kg; SAR(10 g) = 0.264 W/kg

Maximum value of SAR (measured) = 1.92 W/kg

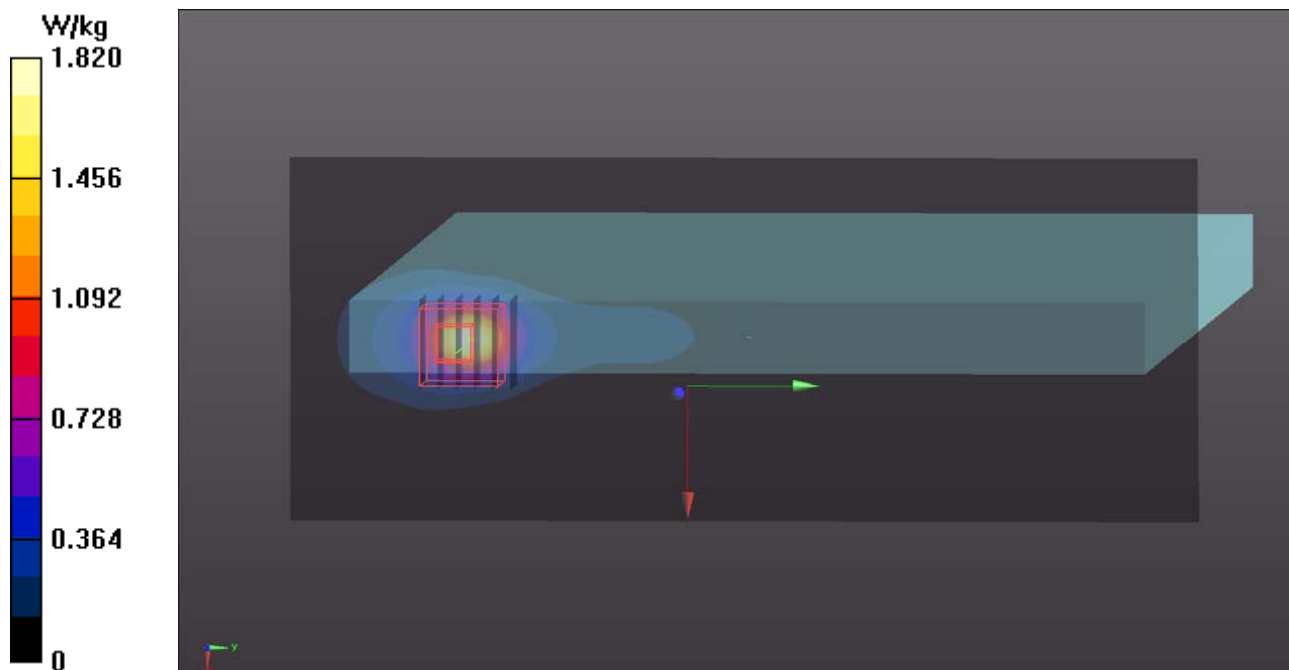

P03 5.6G WLAN_802.11ac VH80_Left Side_0cm_Ch138_Ant0

DUT: 160922C07

Communication System: WLAN_5G; Frequency: 5690 MHz; Duty Cycle: 1:1

Medium: B34T60N2_1013 Medium parameters used: $f = 5690$ MHz; $\sigma = 5.884$ S/m; $\epsilon_r = 48.535$; $\rho = 1000$ kg/m³

Ambient Temperature : 23.9 °C ; Liquid Temperature : 23.3 °C

DASY5 Configuration:

- Probe: EX3DV4 - SN3864; ConvF(3.85, 3.85, 3.85); Calibrated: 2016/07/25;
- Sensor-Surface: 1.4mm (Mechanical Surface Detection)
- Electronics: DAE4 Sn1431; Calibrated: 2016/03/21
- Phantom: ELI Phantom_1245; Type: QDOVA;
- Measurement SW: DASY52, Version 52.8 (8); SEMCAD X Version 14.6.10 (7373)

- **Area Scan (81x251x1):** Interpolated grid: dx=1.000 mm, dy=1.000 mm

Maximum value of SAR (interpolated) = 1.02 W/kg

- **Zoom Scan (6x6x12)/Cube 0:** Measurement grid: dx=5mm, dy=5mm, dz=2mm

Reference Value = 2.412 V/m; Power Drift = 0.06 dB

Peak SAR (extrapolated) = 4.85 W/kg

SAR(1 g) = 1.15 W/kg; SAR(10 g) = 0.348 W/kg

Maximum value of SAR (measured) = 2.65 W/kg

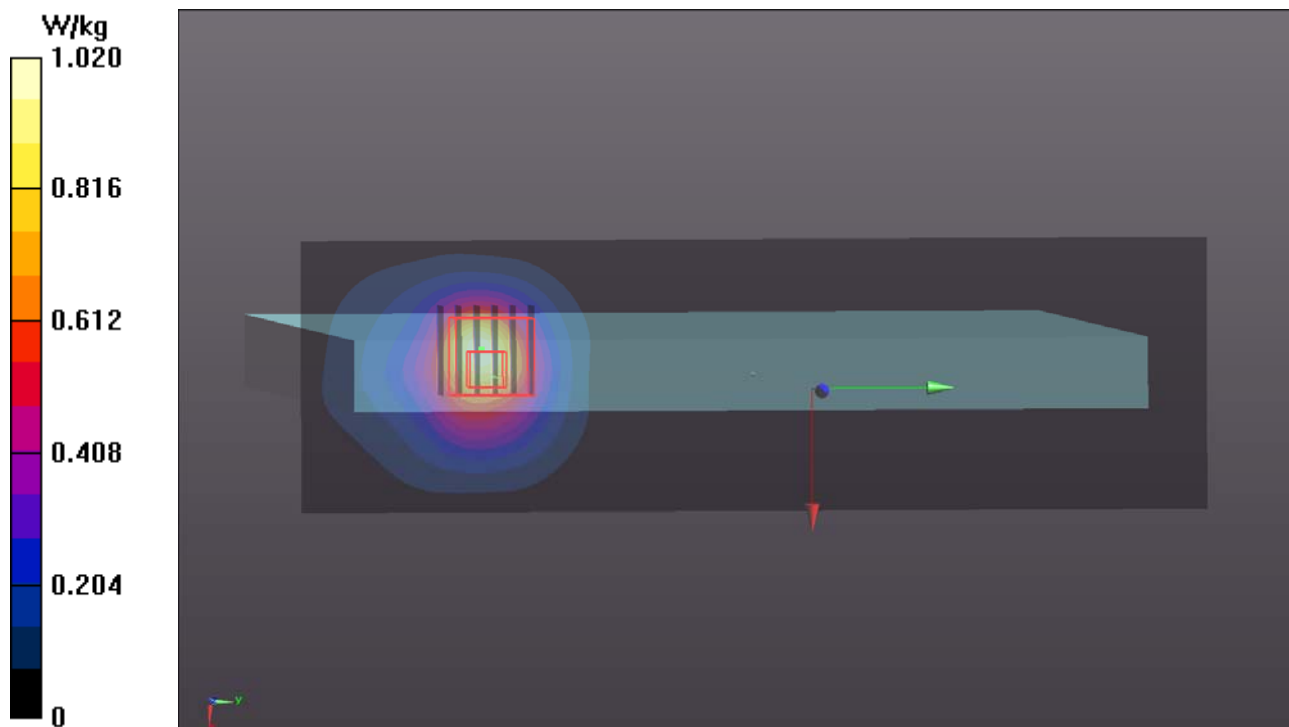

P04 5.8G WLAN_802.11ac VH80_Left Side_0cm_Ch155_Ant0

DUT: 160922C07

Communication System: WLAN_5G; Frequency: 5775 MHz; Duty Cycle: 1:1

Medium: B34T60N2_1006 Medium parameters used: $f = 5775$ MHz; $\sigma = 6.034$ S/m; $\epsilon_r = 48.389$; $\rho =$

1000 kg/m³

Ambient Temperature : 23.7 °C ; Liquid Temperature : 23.4 °C

DASY5 Configuration:

- Probe: EX3DV4 - SN3650; ConvF(4.36, 4.36, 4.36); Calibrated: 2016/07/25;
- Sensor-Surface: 1.4mm (Mechanical Surface Detection)
- Electronics: DAE4 Sn861; Calibrated: 2016/06/16
- Phantom: ELI Phantom_1039; Type: QDOVA;
- Measurement SW: DASY52, Version 52.8 (8); SEMCAD X Version 14.6.10 (7373)

- **Area Scan (61x261x1):** Interpolated grid: dx=1.000 mm, dy=1.000 mm

Maximum value of SAR (interpolated) = 1.61 W/kg

- **Zoom Scan (6x6x12)/Cube 0:** Measurement grid: dx=5mm, dy=5mm, dz=2mm

Reference Value = 3.255 V/m; Power Drift = 0.02 dB

Peak SAR (extrapolated) = 4.42 W/kg

SAR(1 g) = 1.08 W/kg; SAR(10 g) = 0.353 W/kg

Maximum value of SAR (measured) = 2.64 W/kg

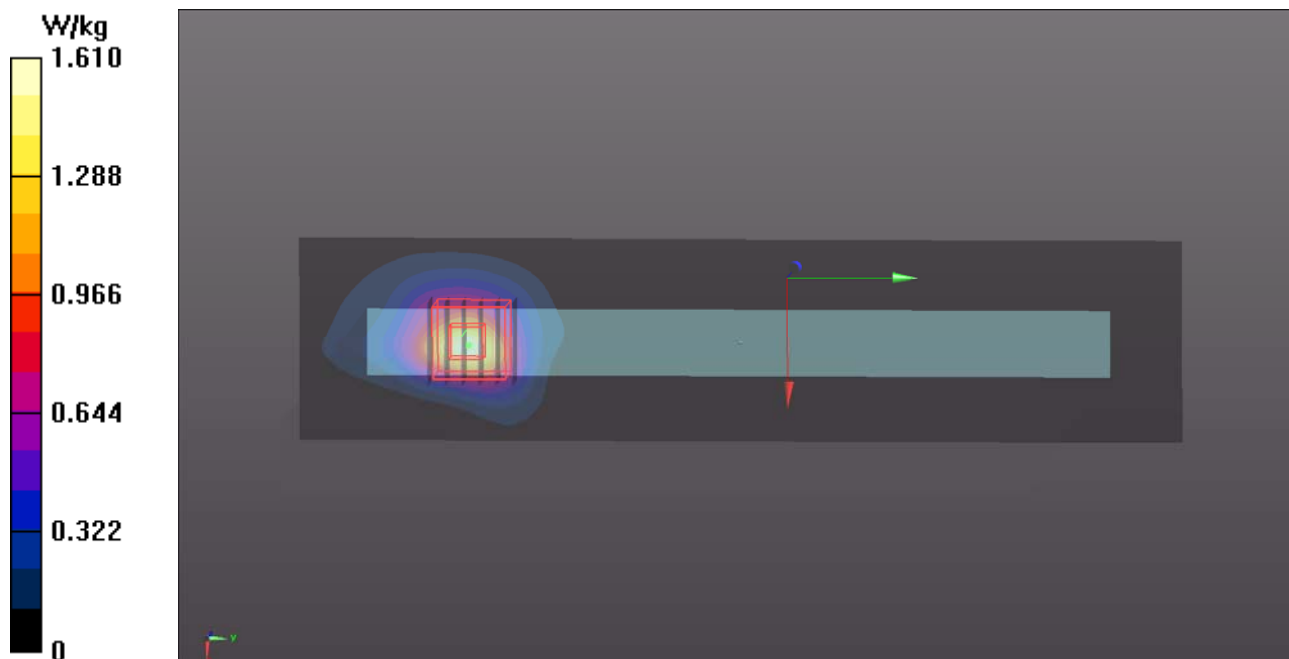

P05 Bluetooth_Left Side_0cm_Ch39

DUT: 160922C07

Communication System: BT; Frequency: 2441 MHz; Duty Cycle: 1:3.02

Medium: B19T27N1_1011 Medium parameters used: $f = 2441$ MHz; $\sigma = 1.971$ S/m; $\epsilon_r = 51.109$; $\rho = 1000$ kg/m³

Ambient Temperature : 23.7 °C ; Liquid Temperature : 23.1 °C

DASY5 Configuration:

- Probe: EX3DV4 - SN3650; ConvF(7.36, 7.36, 7.36); Calibrated: 2016/07/25;
- Sensor-Surface: 1.4mm (Mechanical Surface Detection)
- Electronics: DAE4 Sn861; Calibrated: 2016/06/16
- Phantom: ELI Phantom_1204; Type: QDOVA;
- Measurement SW: DASY52, Version 52.8 (8); SEMCAD X Version 14.6.10 (7373)

- **Area Scan (71x211x1):** Interpolated grid: dx=1.200 mm, dy=1.200 mm

Maximum value of SAR (interpolated) = 0.00236 W/kg

- **Zoom Scan (5x5x7)/Cube 0:** Measurement grid: dx=8mm, dy=8mm, dz=5mm

Reference Value = 0.9090 V/m; Power Drift = 0.09 dB

Peak SAR (extrapolated) = 0.0110 W/kg

SAR(1 g) = 0.00546 W/kg; SAR(10 g) = 0.00303 W/kg

Maximum value of SAR (measured) = 0.00877 W/kg

