



RADIO TEST REPORT

Test Report No. : 11232955H-B

Applicant : PANASONIC CORPORATION OF NORTH AMERICA

Type of Equipment : Wireless Module
(For installation within Panasonic Tablet PC FZ-M1)

Model No. : WL13A

FCC ID : ACJ9TGWL13A

Test regulation : FCC Part 15 Subpart E: 2015

Test Result : Complied

1. This test report shall not be reproduced in full or partial, without the written approval of UL Japan, Inc.
2. The results in this report apply only to the sample tested.
3. This sample tested is in compliance with the above regulation.
4. The test results in this report are traceable to the national or international standards.
5. This test report must not be used by the customer to claim product certification, approval, or endorsement by NVLAP, NIST, or any agency of the Federal Government.
6. This test report covers Radio technical requirements. It does not cover administrative issues such as Manual or non-Radio test related Requirements. (if applicable)

Date of test: April 15 to 21, 2016

Representative test engineer:

T. Nakagawa

Tomohisa Nakagawa
Engineer
Consumer Technology Division

Approved by:

T. Hatakeda

Takahiro Hatakeda
Leader
Consumer Technology Division



NVLAP LAB CODE: 200572-0

This laboratory is accredited by the NVLAP LAB CODE 200572-0, U.S.A. The tests reported herein have been performed in accordance with its terms of accreditation.
*As for the range of Accreditation in NVLAP, you may refer to the WEB address,
http://japan.ul.com/resources/emc_accredited/

UL Japan, Inc.

Ise EMC Lab.

4383-326 Asama-cho, Ise-shi, Mie-ken 516-0021 JAPAN

Telephone : +81 596 24 8999

Facsimile : +81 596 24 8124

13-EM-F0429

CONTENTS	PAGE
SECTION 1: Customer information.....	4
SECTION 2: Equipment under test (E.U.T.).....	4
SECTION 3: Test specification, procedures & results.....	5
SECTION 4: Operation of E.U.T. during testing.....	8
SECTION 5: Conducted Emission.....	11
SECTION 6: Radiated Spurious Emission and Band Edge Compliance.....	12
SECTION 7: Antenna Terminal Conducted Tests.....	14
APPENDIX 1: Test data	15
Conducted Emission	15
99 % Occupied Bandwidth.....	16
6 dB Bandwidth	19
Maximum Conducted Output Power	22
Burst rate confirmation	50
Maximum Power Spectral Density	51
Radiated Spurious Emission	59
Conducted Spurious Emission	71
APPENDIX 2: Test instruments	72
APPENDIX 3: Photographs of test setup	73
Conducted Emission	73
Radiated Spurious Emission	74
Worst Case Position	75

SECTION 1: Customer information

Company Name : PANASONIC CORPORATION OF NORTH AMERICA
Address : Two Riverfront Plaza, 9th Floor, Newark, NJ 07102-5490

SECTION 2: Equipment under test (E.U.T.)

2.1 Identification of E.U.T.

Type of Equipment : Wireless Module
(For installation within Panasonic Tablet PC FZ-M1)
Model No. : WL13A
Serial No. : Refer to Section 4, Clause 4.2
Receipt Date of Sample : April 15, 2016
Modification of EUT : No Modification by the test lab

2.2 Product Description

Model: WL13A (referred to as the EUT in this report) is a Wireless Module.

Radio Specification

Tx Frequency Bands	802.11a/b/g/n/ac: 2412 - 2472 MHz, b / g / HT20 / HT40 5180 - 5240 MHz, a / HT20 / HT40 / HT80 5260 - 5320 MHz, a / HT20 / HT40 / HT80 5500 - 5720 MHz, a / HT20 / HT40 / HT80 5745 - 5825 MHz, a / HT20 / HT40 / HT80 Bluetooth: 2402 - 2480 MHz
Modulation	802.11a/b/g/n/ac : BPSK, QPSK, CCK, 16-QAM and 64-QAM and 256-QAM Bluetooth 4.0+LE: GFSK, DQPSK, 8-DPSK

SECTION 3: Test specification, procedures & results

3.1 Test Specification

Test Specification : FCC Part 15 Subpart E: 2015, final revised on November 23, 2015
*Some parts are effective on and after December 17, 2015 or December 23, 2015. The revision does not affect the test specification applied to the EUT.

Title : FCC 47CFR Part15 Radio Frequency Device Subpart E
Unlicensed National Information Infrastructure Devices
Section 15.407 General technical requirements

3.2 Procedures and results

Item	Test Procedure	Specification	Worst margin	Results	Remarks
Conducted Emission	FCC: ANSI C63.10-2013	FCC: 15.407 (b) (6) / 15.207	QP 19.7 dB, 0.15950 MHz, L AV 25.7 dB, 18.21666 MHz, L	Complied	-
	IC: RSS-Gen 8.8	IC: RSS-Gen 8.8			
26 dB Emission Bandwidth	FCC: KDB Publication Number 789033 D02 v01r02 662911 D01 v02r01 662911 D02 v01	FCC: 15.407 (a) (1) (2) (3)	See data	N/A	Conducted
	IC: -	IC: -			
Maximum Conducted Output Power	FCC: KDB Publication Number 789033 D02 v01r02 662911 D01 v02r01 662911 D02 v01	FCC: 15.407 (a) (1) (2) (3)	See data	Complied	Conducted
	IC: -	IC: RSS-247 6.2.1 (1) 6.2.2 (1) 6.2.3 (1) 6.2.4 (1)			
Maximum Power Spectral Density	FCC: KDB Publication Number 789033 D02 v01r02 662911 D01 v02r01 662911 D02 v01	FCC : 15.407 (a) (1) (2) (3)	See data	Complied	Conducted
	IC: -	IC: RSS-247 6.2.1 (1) 6.2.2 (1) 6.2.3 (1) 6.2.4 (1)			
Spurious Emission Restricted Band Edge	FCC: KDB Publication Number 789033 D02 v01r02 662911 D01 v02r01 662911 D02 v01	FCC: 15.407 (b), 15.205 and 15.209	3.6 dB 698.598 MHz, QP, Vert.	Complied	Conducted (< 30 MHz) / Radiated (> 30 MHz) *1)
	IC: -	IC: RSS-247 6.2.1 (2) 6.2.2 (2) 6.2.3 (2) 6.2.4 (2)			
6 dB Emission Bandwidth	FCC: ANSI C63.10-2013	FCC: 15.407 (e)	See data	Complied	Conducted
	IC: -	IC: RSS-247 6.2.4 (1)			

Note: UL Japan, Inc.'s EMI Work Procedures No. 13-EM-W0420 and 13-EM-W0422.

*1) Radiated test was selected over 30 MHz based on section FCC 15.407 (b) and KDB 789033 D02 G.3.b).

* In case any questions arise about test procedure, ANSI C63.10: 2013 is also referred.

3.3 Addition to standard

Item	Test Procedure	Specification	Worst margin	Results	Remarks
99 % Occupied Band Width	RSS-Gen 6.6	IC: -	N/A	N/A	Conducted

Other than above, no addition, exclusion nor deviation has been made from the standard.

UL Japan, Inc.

Ise EMC Lab.

4383-326 Asama-cho, Ise-shi, Mie-ken 516-0021 JAPAN

Telephone : +81 596 24 8999

Facsimile : +81 596 24 8124

3.4 Uncertainty

EMI

The following uncertainties have been calculated to provide a confidence level of 95 % using a coverage factor $k=2$.
Ise EMC Lab.

Antenna terminal test Uncertainty (+/-)							
Power meter		Conducted emission and Power density			Conducted emission		Channel power
Below 1 GHz	Above 1 GHz	Below 1 GHz	1 GHz -3 GHz	3 GHz -18 GHz	18 GHz -26.5 GHz	26.5 GHz -40 GHz	
0.9 dB	1.0 dB	1.4 dB	1.7 dB	2.8 dB	2.8 dB	2.9 dB	

Frequency range	Conducted emission using AMN(LISN) (+dB)
0.009 – 0.15MHz	3.5 dB
0.15 – 30MHz	2.9 dB

Test distance	Radiated emission (+dB) 9 kHz - 30 MHz
3m	3.8 dB
10m	3.7 dB

Polarity	Radiated emission (Below 1GHz)			
	(3 m*)(+dB)		(10 m*)(+dB)	
	30 – 200 MHz	200 – 1000MHz	30 – 200 MHz	200 – 1000MHz
Horizontal	4.8 dB	5.2 dB	4.8 dB	5.0 dB
Vertical	4.5 dB	5.9 dB	4.8 dB	5.1 dB

Radiated emission				
(3 m*)(+dB)		(1 m*)(+dB)	(0.5 m*)(+dB)	(10 m*)(+dB)
1 – 6GHz	6 – 18GHz	10 – 26.5 GHz	26.5 – 40GHz	1 -18 GHz
5.1 dB	5.3 dB	5.1 dB	5.1 dB	5.3 dB

*Measurement distance

Conducted Emission test

The data listed in this test report has enough margin, more than the site margin.

Radiated emission test

The data listed in this report meets the limits unless the uncertainty is taken into consideration.

3.5 Test Location

UL Japan, Inc. Ise EMC Lab. *NVLAP Lab. code: 200572-0
4383-326 Asama-cho, Ise-shi, Mie-ken 516-0021 JAPAN
Telephone: +81 596 24 8999, Facsimile: +81 596 24 8124

Test site	IC Registration Number	Width x Depth x Height (m)	Size of reference ground plane (m) / horizontal conducting plane	Other rooms	Maximum measurement distance
No.1 semi-anechoic chamber	2973C-1	19.2 x 11.2 x 7.7	7.0 x 6.0	No.1 Power source room	10 m
No.2 semi-anechoic chamber	2973C-2	7.5 x 5.8 x 5.2	4.0 x 4.0	-	3 m
No.3 semi-anechoic chamber	2973C-3	12.0 x 8.5 x 5.9	6.8 x 5.75	No.3 Preparation room	3 m
No.3 shielded room	-	4.0 x 6.0 x 2.7	N/A	-	-
No.4 semi-anechoic chamber	2973C-4	12.0 x 8.5 x 5.9	6.8 x 5.75	No.4 Preparation room	3 m
No.4 shielded room	-	4.0 x 6.0 x 2.7	N/A	-	-
No.5 semi-anechoic chamber	-	6.0 x 6.0 x 3.9	6.0 x 6.0	-	-
No.6 shielded room	-	4.0 x 4.5 x 2.7	4.0 x 4.5	-	-
No.6 measurement room	-	4.75 x 5.4 x 3.0	4.75 x 4.15	-	-
No.7 shielded room	-	4.7 x 7.5 x 2.7	4.7 x 7.5	-	-
No.8 measurement room	-	3.1 x 5.0 x 2.7	N/A	-	-
No.9 measurement room	-	8.8 x 4.6 x 2.8	2.4 x 2.4	-	-
No.11 measurement room	-	6.2 x 4.7 x 3.0	4.8 x 4.6	-	-

* Size of vertical conducting plane (for Conducted Emission test) : 2.0 x 2.0 m for No.1, No.2, No.3, and No.4 semi-anechoic chambers and No.3 and No.4 shielded rooms.

3.6 Test data, Test instruments, and Test set up

Refer to APPENDIX.

SECTION 4: Operation of E.U.T. during testing

4.1 Operating Mode(s)

Test operating mode was determined as follows according to “Section 1 of 6 802.11 a/b/g/n testing - Managing Complex Regulatory Approvals -” of TCB Council Workshop October 2009 and also was judged the necessity of 802.11ac mode by the pre-test.

Mode	Remarks*
IEEE 802.11a (11a)	6 Mbps, PN9
IEEE 802.11n SISO 20 MHz BW (11n-20)	MCS 0 (Long GI), PN9
IEEE 802.11ac SISO 20 MHz BW (11ac-20)	VHT 0 (Long GI), PN9
IEEE 802.11n MIMO 20 MHz BW (11n-20)	MCS 15 (Long GI), PN9
IEEE 802.11ac MIMO 20 MHz BW (11ac-20)	VHT 8 (Long GI), PN9
IEEE 802.11n SISO 40 MHz BW (11n-40)	MCS 7 (Long GI), PN9
IEEE 802.11ac SISO 40 MHz BW (11ac-40)	VHT 9 (Long GI), PN9
IEEE 802.11n MIMO 40 MHz BW (11n-40)	MCS 15 (Long GI), PN9
IEEE 802.11ac MIMO 40 MHz BW (11ac-40)	VHT 9 (Long GI), PN9
IEEE 802.11ac SISO 80 MHz BW (11ac-80)	VHT 9 (Long GI), PN9
IEEE 802.11ac MIMO 80 MHz BW (11ac-80)	VHT 9 (Long GI), PN9

*Above worst rate was decided based on a maximum conducted output power rate check (reference data) result.

*The details of Operation mode(s)

Test Item	Operating Mode	Tested Antenna	Tested Frequency
			Upper Band
Conducted Emission, Radiated Spurious Emission (Below 1 GHz), Conducted Spurious Emission *1)	11ac-40 Tx *2)	A+B	5795 MHz
99 % Occupied Bandwidth, 6 dB Bandwidth *1)	11a Tx 11ac-20 Tx	B	5745 MHz 5785 MHz 5825 MHz
	11ac-40 Tx	B	5755 MHz 5795 MHz
	11ac-80 Tx	B	5775 MHz
Maximum Power Spectral Density *1)	11a Tx	A, B	5745 MHz 5785 MHz 5825 MHz
	11ac-20 Tx	A+B	5745 MHz 5785 MHz 5825 MHz
	11ac-40 Tx	A+B	5755 MHz 5795 MHz
	11ac-80 Tx	A+B	5775 MHz
Maximum Conducted Output Power *1)	11a Tx	A, B	5745 MHz 5785 MHz 5825 MHz
	11n-20 Tx 11ac-20 Tx	A, B, A+B	5745 MHz 5785 MHz 5825 MHz
	11n-40 Tx 11ac-40 Tx	A, B, A+B	5755 MHz 5795 MHz
	11ac-80 Tx	A, B, A+B	5775 MHz
Radiated Spurious Emission (Above 1 GHz) *1)	11ac-20 Tx	A+B *3)	5745 MHz 5785 MHz 5825 MHz
	11ac-40 Tx	A+B *3)	5755 MHz 5795 MHz
	11ac-80 Tx	A+B *3)	5775 MHz

*1) The test was only performed with UNII-3 band.

*2) The test was performed with the worst case.

The highest mode in Maximum conducted output power result was selected as the worst case.

The highest rate in Maximum conducted output power rate check (reference data) result was selected as the worst case.

*3) After the comparison MIMO and SISO in pre-check, test was performed with MIMO as a representative as it had worst case.

UL Japan, Inc.

Ise EMC Lab.

4383-326 Asama-cho, Ise-shi, Mie-ken 516-0021 JAPAN

Telephone : +81 596 24 8999

Facsimile : +81 596 24 8124

4.2 Configuration and peripherals

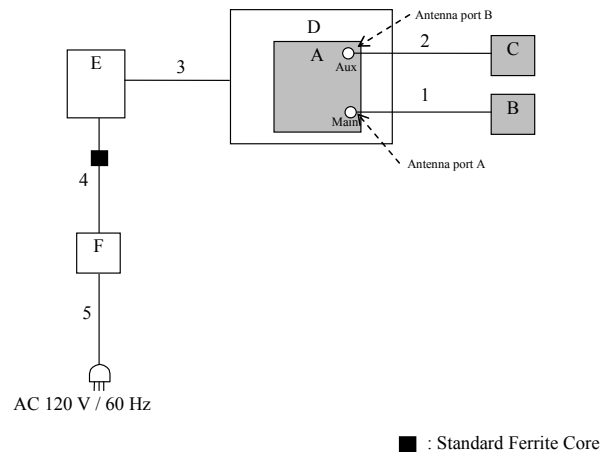

* Cabling and setup(s) were taken into consideration and test data was taken under worse case conditions.

Description of EUT and Support equipment

No.	Item	Model number	Serial number	Manufacturer	Remarks
A	Wireless Module	WL13A	710663-001 OH	Panasonic	EUT
B	Main antenna	DFUP24642A	-	Panasonic	EUT
C	Aux antenna	DFUP2534ZA	-	Panasonic	EUT
D	Jig board	-	600038450	-	-
E	Jig	-	C151215-022-006-004	Panasonic	-
F	AC Adapter	CF-AA64B3C M1	M1150303713C	Panasonic	-

List of cables used

No.	Name	Length (m)	Shield		Remarks
			Cable	Connector	
1	Antenna Cable	0.80	Unshielded	Unshielded	-
2	Antenna Cable	0.50	Unshielded	Unshielded	-
3	Signal Cable	0.15	Unshielded	Unshielded	-
4	DC Cable	0.90	Unshielded	Unshielded	-
5	AC Cable	1.90	Unshielded	Unshielded	-

SECTION 5: Conducted Emission

Test Procedure and conditions

EUT was placed on a urethane platform of nominal size, 1.0 m by 1.5 m, raised 0.8 m above the conducting ground plane.

The rear of tabletop was located 40cm to the vertical conducting plane. The rear of EUT, including peripherals aligned and flushed with rear of tabletop. All other surfaces of tabletop were at least 80cm from any other grounded conducting surface. EUT was located 80cm from a Line Impedance Stabilization Network (LISN) / Artificial mains Network (AMN) and excess AC cable was bundled in center.

For the tests on EUT with other peripherals (as a whole system)

I/O cables that were connected to the peripherals were bundled in center. They were folded back and forth forming a bundle 30 cm to 40 cm long and were hanged at a 40 cm height to the ground plane. All unused 50 ohm connectors of the LISN (AMN) were resistivity terminated in 50 ohm when not connected to the measuring equipment.

The AC Mains Terminal Continuous disturbance Voltage has been measured with the EUT in a Semi Anechoic Chamber.

The EUT was connected to a LISN (AMN).

An overview sweep with peak detection has been performed.

The test results and limit are rounded off to one decimal place, so some differences might be observed.

Detector	: QP and CISPR Average
Measurement range	: 0.15 MHz-30 MHz
Test data	: APPENDIX
Test result	: Pass

SECTION 6: Radiated Spurious Emission and Band Edge Compliance

Test Procedure

[For below 1GHz]

EUT was placed on a urethane platform of nominal size, 0.5 m by 1.0 m, raised 0.8 m above the conducting ground plane. The Radiated Electric Field Strength has been measured in a Semi Anechoic Chamber with a ground plane.

[For above 1GHz]

EUT was placed on a urethane platform of nominal size, 0.5 m by 0.75 m, raised 1.5 m above the conducting ground plane.

The Radiated Electric Field Strength has been measured in a Semi Anechoic Chamber with absorbent materials lined on a ground plane.

The height of the measuring antenna varied between 1 and 4 m and EUT was rotated a full revolution in order to obtain the maximum value of the electric field strength.

The measurements were performed for both vertical and horizontal antenna polarization with the Test Receiver, or the Spectrum Analyzer.

The measurements were made with the following detector function of the test receiver and the Spectrum analyzer (in linear mode).

The test was made with the detector (RBW/VBW) in the following table.

When using Spectrum analyzer, the test was made with adjusting span to zero by using peak hold.

< Below 1GHz >

The result also satisfied with the general limits specified in section 15.209 (a).

< Above 1GHz >

Inside of restricted bands (Section 15.205):

Apply to limit in the Section 15.209 (a).

Outside of the restricted bands:

Apply to limit 68.2 dBuV/m, 3 m (-27 dBm e.i.r.p. *) in the Section 15.407 (b) (1) (2) (3).

-27 dBm/MHz at 75 MHz or more above or below the band edge increasing linearly to 10 dBm/MHz at 25 MHz above or below the band edge, and from 25 MHz above or below the band edge increasing linearly to a level of 15.6 dBm/MHz at 5 MHz above or below the band edge, and from 5 MHz above or below the band edge increasing linearly to a level of 27 dBm/MHz at the band edge in the KDB926956 D01.

Restricted band edge:

Apply to limit in the Section 15.209 (a).

Since this limit is severer than the limit of the inside of restricted bands.

*Electric field strength to e.i.r.p. conversion:

$$E = \frac{1000000\sqrt{30P}}{3} \text{ (uV/m)} \quad ; P \text{ is the e.i.r.p. (Watts)}$$

Test Antennas are used as below;

Frequency	30 MHz to 200 MHz	200 MHz to 1 GHz	Above 1 GHz
Antenna Type	Biconical	Logperiodic	Horn

Frequency	Below 1 GHz	Above 1 GHz	
Instrument used	Test Receiver	Spectrum Analyzer	
Detector	QP	Peak	Average
IF Bandwidth	BW: 120 kHz	RBW: 1 MHz VBW: 3 MHz	Method AD *1) RBW: 1 MHz VBW: 3 MHz Detector: Power Averaging (RMS) Trace: ≥ 100 traces Duty factor was added to the results.
Test Distance	3 m	3.9 m *2) (below 10 GHz), 1 m *3) (above 10 GHz), 0.5 m *4) (above 26.5 GHz)	

*1) The test method was also referred to KDB 789033 D02 General UNII Test Procedures New Rules v01r02 "Guidelines for Compliance Testing of Unlicensed National Information Infrastructure (U-NII) Devices Part 15, Subpart E (Issued on April 8, 2016)".

*2) Distance Factor: $20 \times \log(3.9 \text{ m}/3.0 \text{ m}) = 2.28 \text{ dB}$

*3) Distance Factor: $20 \times \log(1.0 \text{ m}/3.0 \text{ m}) = -9.5 \text{ dB}$

*4) Distance Factor: $20 \times \log(0.5 \text{ m}/3.0 \text{ m}) = -15.6 \text{ dB}$

- The carrier level and noise levels were confirmed at each position of X, Y and Z axes of EUT (Antenna and Module) to see the position of maximum noise, and the test was made at the position that has the maximum noise.

The test results and limit are rounded off to one decimal place, so some differences might be observed.

Measurement range : 30 MHz-40 GHz
Test data : APPENDIX
Test result : Pass

SECTION 7: Antenna Terminal Conducted Tests

Test Procedure

The tests were made with below setting connected to the antenna port.

Test	Span	RBW	VBW	Sweep time	Detector	Trace	Instrument used and Test method
99 % Occupied Bandwidth *1)	Enough width to display emission skirts	1 % to 5 % of OBW	≥ 3 RBW	Auto	Peak	Max Hold	Spectrum Analyzer
6 dB Bandwidth	Enough to capture the emission	100 kHz	300 kHz	Auto	Peak	Max Hold	Spectrum Analyzer
Maximum Conducted Output Power	-	-	-	Auto	Average	-	Power Meter (Sensor: 80 MHz BW) (Method PM-G)
Maximum Power Spectral Density	Encompass the entire EBW	470 kHz *2)	≥ 3 RBW	Auto	RMS or Sample Power Averaging (200 times)	Clear Write	Spectrum Analyzer
Conducted Spurious Emission*3)	9 kHz – 150 kHz	200 Hz	620 Hz	Auto	Peak	Max Hold	Spectrum Analyzer
	150 kHz – 30 MHz	9.1 kHz	27 kHz				

* The test method was also referred to KDB 789033 D02 General UNII Test Procedures New Rules v01r02 "Guidelines for Compliance Testing of Unlicensed National Information Infrastructure (U-NII) Devices Part 15, Subpart E (Issued on April 8, 2016)".

*1) Peak hold was applied as Worst-case measurement.

*2) FCC standard says that RBW is set to be 500 kHz for 5.725 GHz-5.850 GHz, but it is not possible with spectrum analyzer, so $10\log(500\text{ kHz}/470\text{ kHz})$ was added to the test result.

*3) In the frequency range below 30 MHz, RBW was narrowed to separate the noise contents.

Then, wide-band noise near the limit was checked separately, however the noise was low enough as shown in the chart. (9 kHz-150 kHz: RBW = 200 Hz, 150 kHz-30 MHz: RBW = 9.1 kHz).

The test results and limit are rounded off to two decimals place, so some differences might be observed.

Test data : APPENDIX
Test result : Pass

APPENDIX 1: Test data

Conducted Emission

DATA OF CONDUCTED EMISSION TEST

UL Japan, Inc. Ise EMC Lab. No.1 Semi Anechoic Chamber
Date : 2016/04/20

Report No. : 11232955H
Temp./Humi. : 23deg. C / 45% RH
Engineer : Tomohisa Nakagawa

Mode / Remarks : Tx 5795MHz 40BW VHT9

LIMIT : FCC15.207 QP
FCC15.207 AV

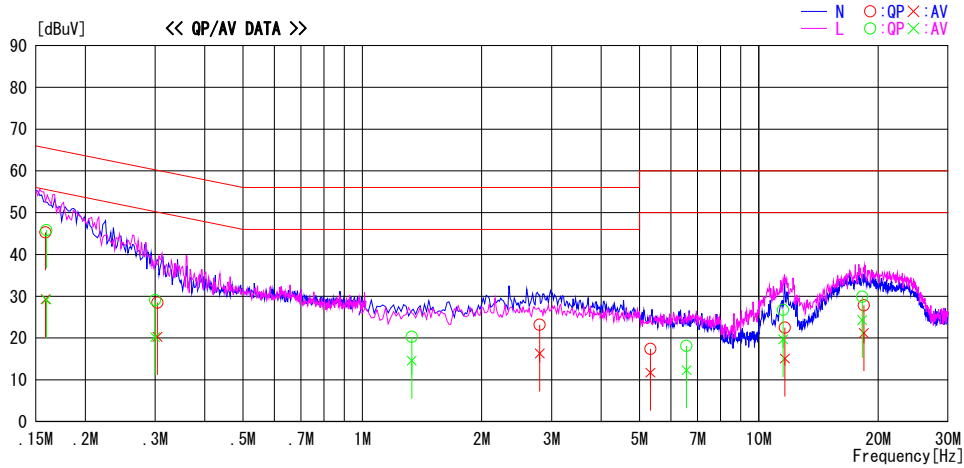

Frequency [MHz]	Reading Level		Corr. Factor [dB]	Results		Limit		Margin		Phase	Comment
	QP [dBuV]	AV [dBuV]		QP [dBuV]	AV [dBuV]	QP [dBuV]	AV [dBuV]	QP [dB]	AV [dB]		
0.15888	32.1	16.1	13.2	45.3	29.3	65.5	55.5	20.2	26.2	N	
0.30408	15.2	7.0	13.3	28.5	20.3	60.1	50.1	31.6	29.8	N	
2.80167	9.5	2.6	13.7	23.2	16.3	56.0	46.0	32.8	29.7	N	
5.32917	3.3	-2.4	14.1	17.4	11.7	60.0	50.0	42.6	38.3	N	
11.62916	8.0	0.6	14.5	22.5	15.1	60.0	50.0	37.5	34.9	N	
18.39833	12.7	6.1	15.1	27.8	21.2	60.0	50.0	32.2	28.8	N	
0.15950	32.6	16.0	13.2	45.8	29.2	65.5	55.5	19.7	26.3	L	
0.30000	15.8	6.9	13.3	29.1	20.2	60.2	50.2	31.1	30.0	L	
1.33167	6.8	1.1	13.5	20.3	14.6	56.0	46.0	35.7	31.4	L	
6.57000	4.0	-1.8	14.1	18.1	12.3	60.0	50.0	41.9	37.7	L	
11.52000	12.2	5.2	14.5	26.7	19.7	60.0	50.0	33.3	30.3	L	
18.21666	14.8	9.2	15.1	29.9	24.3	60.0	50.0	30.1	25.7	L	

CHART : WITH FACTOR, Peak hold data. CALCULATION : RESULT = READING + C.F (LISN + ATTEN. + CABLE)
Except for the above table : adequate margin data below the limits.

99 % Occupied Bandwidth

Test place : Ise EMC Lab. No.3 Measurement Room
Report No. : 11232955H
Date : April 20, 2016
Temperature / Humidity : 23deg. C / 35 % RH
Engineer : Yutaka Yoshida
Mode : Tx

11a

Antenna	Tested Frequency [MHz]	26 dB Emission Bandwidth [MHz]	99 % Occupied Bandwidth [MHz]	Limit [MHz]
Antenna B	5745	-	17.180	-
	5785	-	17.161	-
	5825	-	17.159	-

11ac-20 MIMO VHT8

Antenna	Tested Frequency [MHz]	26 dB Emission Bandwidth [MHz]	99 % Occupied Bandwidth [MHz]	Limit [MHz]
Antenna B	5745	-	18.039	-
	5785	-	17.968	-
	5825	-	18.037	-

11ac-40 MIMO VHT9

Antenna	Tested Frequency [MHz]	26 dB Emission Bandwidth [MHz]	99 % Occupied Bandwidth [MHz]	Limit [MHz]
Antenna B	5755	-	36.074	-
	5795	-	36.100	-

11ac-80 MIMO VHT9

Antenna	Tested Frequency [MHz]	26 dB Emission Bandwidth [MHz]	99 % Occupied Bandwidth [MHz]	Limit [MHz]
Antenna B	5775	-	74.785	-

99 % Occupied Bandwidth

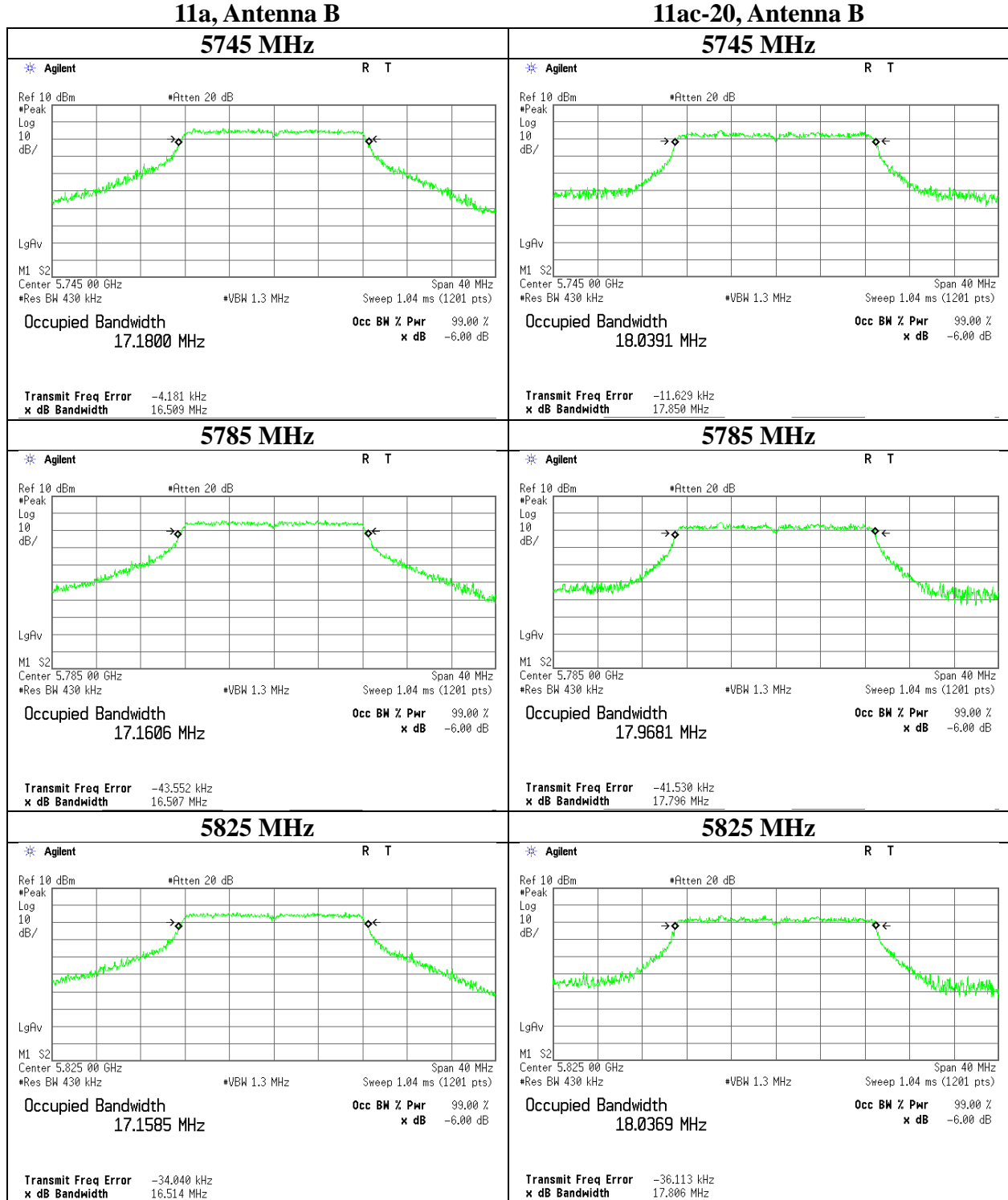

99 % Occupied Bandwidth

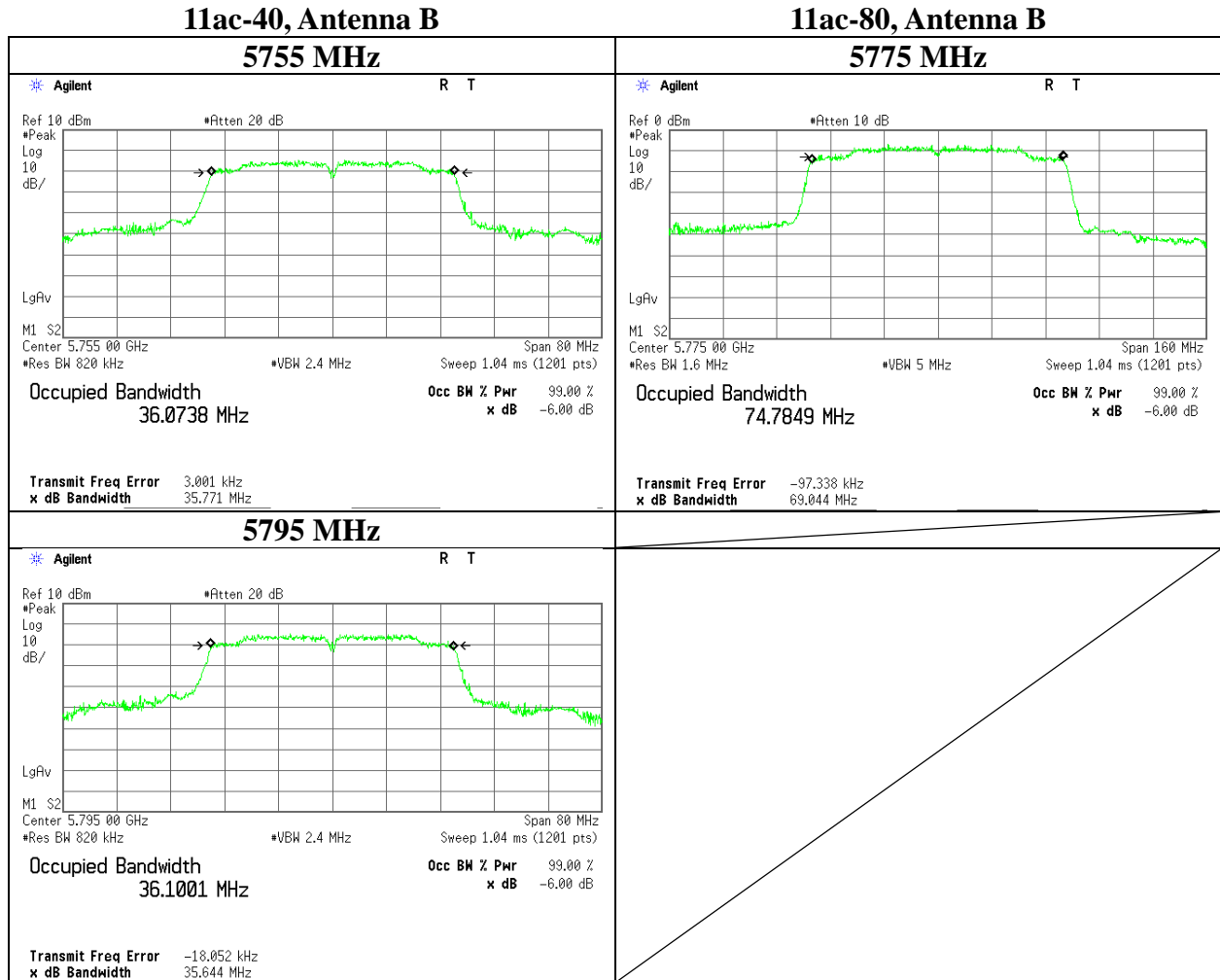

6 dB Bandwidth

Test place Ise EMC Lab. No.3 Measurement Room
Report No. 11232955H
Date April 20, 2016
Temperature / Humidity 23deg. C / 35 % RH
Engineer Yutaka Yoshida
Mode Tx

11a 6Mbps

Antenna	Tested Frequency [MHz]	6 dB Bandwidth [MHz]	Limit [kHz]
Antenna B	5745	16.392	> 500
	5785	16.357	> 500
	5825	16.345	> 500

11ac-20 MIMO VHT8

Antenna	Tested Frequency [MHz]	6 dB Bandwidth [MHz]	Limit [kHz]
Antenna B	5745	17.677	> 500
	5785	17.676	> 500
	5825	17.631	> 500

11ac-40 VHT9

Antenna	Tested Frequency [MHz]	6 dB Bandwidth [MHz]	Limit [kHz]
Antenna B	5755	35.178	> 500
	5795	35.179	> 500

11ac-80 VHT9

Antenna	Tested Frequency [MHz]	6 dB Bandwidth [MHz]	Limit [kHz]
Antenna B	5775	75.152	> 500

6 dB Bandwidth

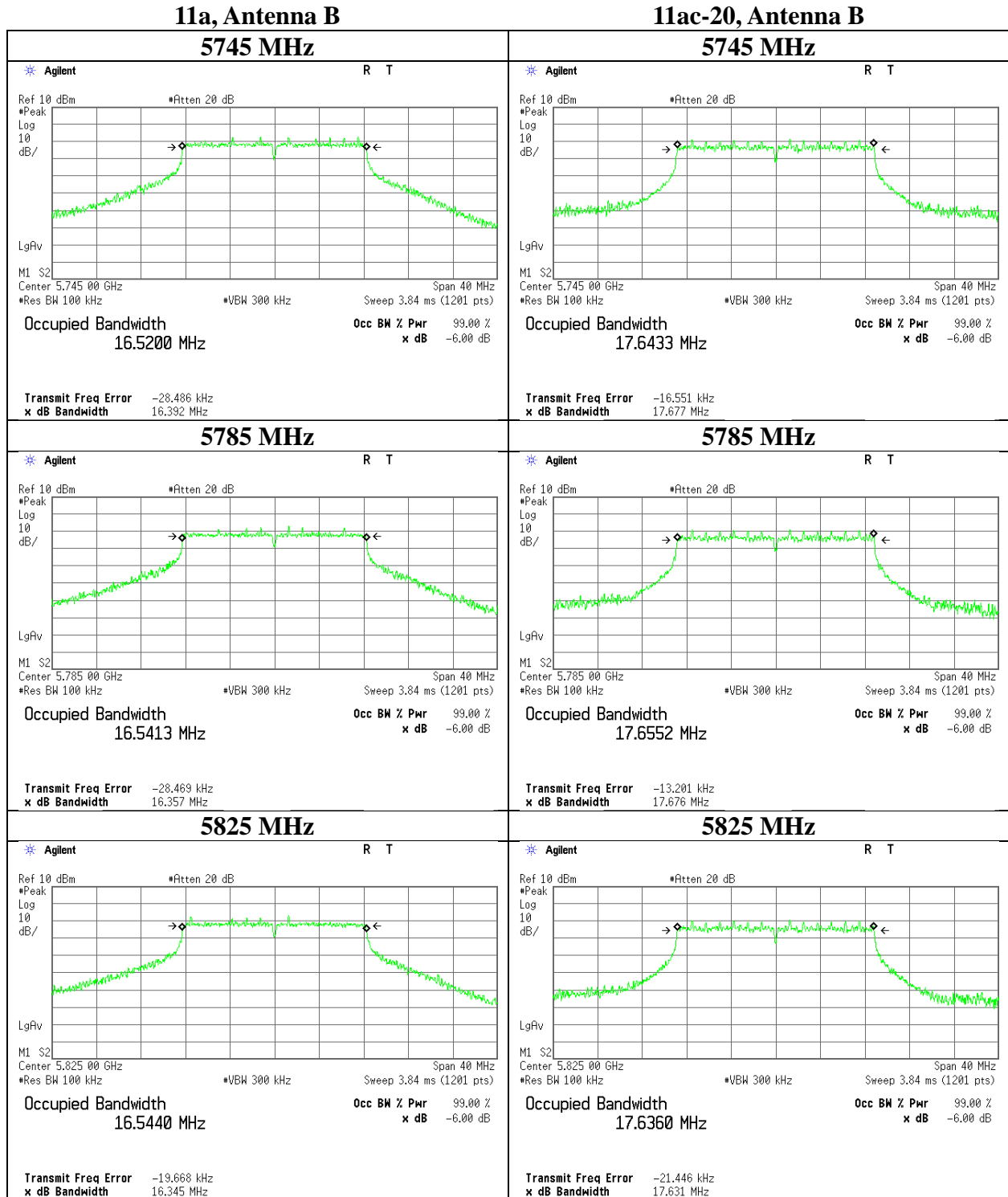

UL Japan, Inc.

Ise EMC Lab.

4383-326 Asama-cho, Ise-shi, Mie-ken 516-0021 JAPAN

Telephone : +81 596 24 8999

Facsimile : +81 596 24 8124

6 dB Bandwidth

11ac-40, Antenna B

5755 MHz

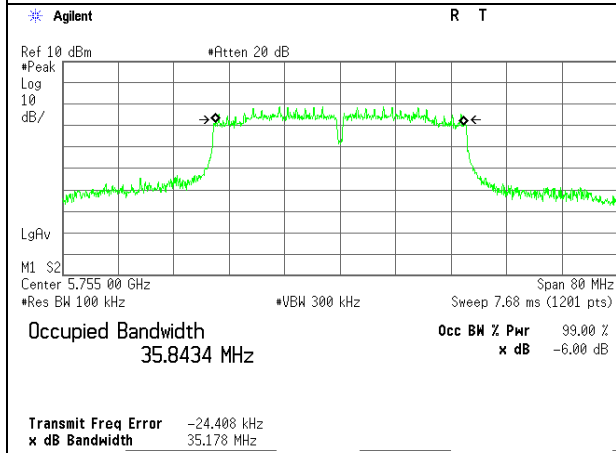

11ac-80, Antenna B

5775 MHz

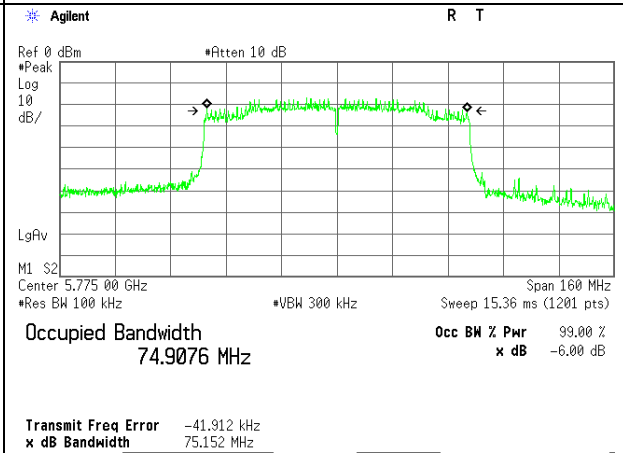

5795 MHz

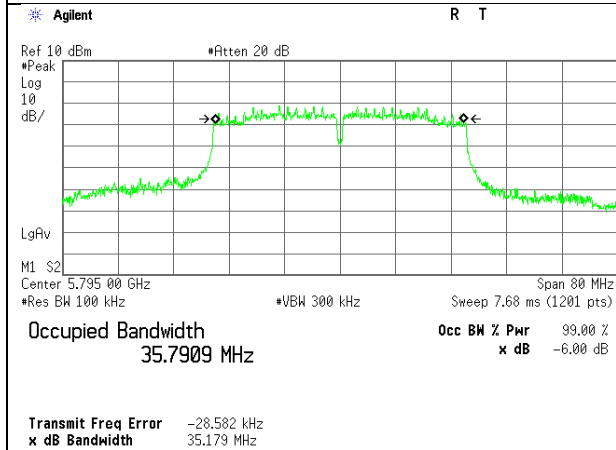

UL Japan, Inc.

Ise EMC Lab.

4383-326 Asama-cho, Ise-shi, Mie-ken 516-0021 JAPAN

Telephone : +81 596 24 8999

Facsimile : +81 596 24 8124

Maximum Conducted Output Power

Test place : Ise EMC Lab. No.6 Measurement Room
Report No. : 11232955H
Date : April 15, 2016
Temperature / Humidity : 24deg. C / 45 % RH
Engineer : Hisayoshi Sato
Mode : Tx 11a 6Mbps

Antenna A

Tested Frequency [MHz]	Power Meter Reading [dBm]	Cable Loss [dB]	Atten. Loss [dB]	Duty Factor [dB]	Antenna Gain [dBi]	Result		Limit [dBm]	Margin [dB]
						[dBm]	[mW]		
5745	3.69	1.53	9.85	0.00	-	15.07	32.12	30.00	14.93
5785	3.51	1.54	9.85	0.00	-	14.90	30.90	30.00	15.10
5825	3.56	1.55	9.85	0.00	-	14.96	31.31	30.00	15.04

Sample Calculation:

Power Result = Reading + Cable Loss + Atten. Loss

Conducted Power Limit (5750 MHz-5825 MHz) = 1W (30dBm)

Antenna B

Tested Frequency [MHz]	Power Meter Reading [dBm]	Cable Loss [dB]	Atten. Loss [dB]	Duty Factor [dB]	Antenna Gain [dBi]	Result		Limit [dBm]	Margin [dB]
						[dBm]	[mW]		
5745	3.80	1.53	9.70	0.00	-	15.03	31.82	30.00	14.97
5785	3.74	1.54	9.70	0.00	-	14.98	31.47	30.00	15.02
5825	3.81	1.55	9.70	0.00	-	15.06	32.04	30.00	14.94

Sample Calculation:

Power Result = Reading + Cable Loss + Atten. Loss

Conducted Power Limit (5750 MHz-5825 MHz) = 1W (30dBm)

Method PM-G(Measurement using a Gated RF average power meter) is used.

Maximum Conducted Output Power

Test place : Ise EMC Lab. No.6 Measurement Room
Report No. : 11232955H
Date : April 15, 2016
Temperature / Humidity : 24deg. C / 45 % RH
Engineer : Hisayoshi Sato
Mode : Tx 11n-20 MCS 0

Antenna A

Tested Frequency [MHz]	Power Meter Reading [dBm]	Cable Loss [dB]	Atten. Loss [dB]	Duty Factor [dB]	Antenna Gain [dBi]	Result		Limit [dBm]	Margin [dB]
						[dBm]	[mW]		
5745	3.47	1.53	9.85	0.00	-	14.85	30.53	30.00	15.15
5785	3.50	1.54	9.85	0.00	-	14.89	30.82	30.00	15.11
5825	3.62	1.55	9.85	0.00	-	15.02	31.74	30.00	14.98

Sample Calculation:

Power Result = Reading + Cable Loss + Atten. Loss

Conducted Power Limit (5750 MHz-5825 MHz) = 1W (30dBm)

Antenna B

Tested Frequency [MHz]	Power Meter Reading [dBm]	Cable Loss [dB]	Atten. Loss [dB]	Duty Factor [dB]	Antenna Gain [dBi]	Result		Limit [dBm]	Margin [dB]
						[dBm]	[mW]		
5745	3.69	1.53	9.70	0.00	-	14.92	31.03	30.00	15.08
5785	3.71	1.54	9.70	0.00	-	14.95	31.25	30.00	15.05
5825	3.72	1.55	9.70	0.00	-	14.97	31.38	30.00	15.03

Sample Calculation:

Power Result = Reading + Cable Loss + Atten. Loss

Conducted Power Limit (5750 MHz-5825 MHz) = 1W (30dBm)

Method PM-G(Measurement using a Gated RF average power meter) is used.

Maximum Conducted Output Power

Test place : Ise EMC Lab. No.6 Measurement Room
Report No. : 11232955H
Date : April 19, 2016
Temperature / Humidity : 22deg. C / 44 % RH
Engineer : Hisayoshi Sato
Mode : Tx 11n-20 MCS 15

Antenna A+B

Tested Frequency [MHz]	Antenna			Result [dBm]	Limit [dBm]	Margin [dB]
	1 [mW]	2 [mW]	Sum [mW]			
5745	16.90	16.36	33.25	15.22	30.00	14.78
5785	15.45	16.18	31.63	15.00	30.00	15.00
5825	15.51	15.19	30.70	14.87	30.00	15.13

Tested Frequency [MHz]	Antenna A					Antenna B				
	Power Meter Reading [dBm]	Cable Loss [dB]	Atten. Loss [dB]	Antenna Gain [dBi]	Result Power [dBm]	Power Meter Reading [dBm]	Cable Loss [dB]	Atten. Loss [dB]	Antenna Gain [dBi]	Result Power [dBm]
5745	0.90	1.53	9.85	-	12.28	0.91	1.53	9.70	-	12.14
5785	0.50	1.54	9.85	-	11.89	0.85	1.54	9.70	-	12.09
5825	0.51	1.55	9.85	-	11.91	0.57	1.55	9.70	-	11.82

Sample Calculation:

Conducted Power Result = Reading + Cable Loss + Atten. Loss

Conducted Power Limit (5750 MHz-5825 MHz) = 1W (30dBm)

Method PM-G(Measurement using a Gated RF average power meter) is used.

Maximum Conducted Output Power

Test place	Ise EMC Lab. No.6 Measurement Room
Report No.	11232955H
Date	April 16, 2016
Temperature / Humidity	24deg. C / 45 % RH
Engineer	Hisayoshi Sato
Mode	Tx 11ac-20 VHT0

Antenna A

Tested Frequency [MHz]	Power Meter Reading [dBm]	Cable Loss [dB]	Atten. Loss [dB]	Duty Factor [dB]	Antenna Gain [dBi]	Result		Limit [dBm]	Margin [dB]
						[dBm]	[mW]		
5745	3.61	1.53	9.85	0.00	-	14.99	31.53	30.00	15.01
5785	3.60	1.54	9.85	0.00	-	14.99	31.55	30.00	15.01
5825	3.62	1.55	9.85	0.00	-	15.02	31.76	30.00	14.98

Sample Calculation:

Power Result = Reading + Cable Loss + Atten. Loss

Conducted Power Limit (5750 MHz-5825 MHz) = 1W (30dBm)

Antenna B

Tested Frequency [MHz]	Power Meter Reading [dBm]	Cable Loss [dB]	Atten. Loss [dB]	Duty Factor [dB]	Antenna Gain [dBi]	Result		Limit [dBm]	Margin [dB]
						[dBm]	[mW]		
5745	3.80	1.53	9.70	0.00	-	15.03	31.82	30.00	14.97
5785	3.72	1.54	9.70	0.00	-	14.96	31.33	30.00	15.04
5825	3.79	1.55	9.70	0.00	-	15.04	31.89	30.00	14.96

Sample Calculation:

Power Result = Reading + Cable Loss + Atten. Loss

Conducted Power Limit (5750 MHz-5825 MHz) = 1W (30dBm)

Method PM-G(Measurement using a Gated RF average power meter) is used.

Maximum Conducted Output Power

Test place : Ise EMC Lab. No.6 Measurement Room
Report No. : 11232955H
Date : April 19, 2016
Temperature / Humidity : 22deg. C / 44 % RH
Engineer : Hisayoshi Sato
Mode : Tx 11ac-20 VHT8

Antenna A+B

Tested Frequency [MHz]	Antenna			Result [dBm]	Limit [dBm]	Margin [dB]
	1 [mW]	2 [mW]	Sum [mW]			
5745	16.90	16.36	33.25	15.22	30.00	14.78
5785	16.63	16.18	32.81	15.16	30.00	14.84
5825	16.54	14.74	31.29	14.95	30.00	15.05

Tested Frequency [MHz]	Antenna A					Antenna B				
	Power Meter Reading [dBm]	Cable Loss [dB]	Atten. Loss [dB]	Antenna Gain [dBi]	Result Power [dBm]	Power Meter Reading [dBm]	Cable Loss [dB]	Atten. Loss [dB]	Antenna Gain [dBi]	Result Power [dBm]
5745	0.90	1.53	9.85	-	12.28	0.91	1.53	9.70	-	12.14
5755	0.82	1.54	9.85	-	12.21	0.85	1.54	9.70	-	12.09
5795	0.79	1.55	9.85	-	12.19	0.44	1.55	9.70	-	11.69

Sample Calculation:

Conducted Power Result = Reading + Cable Loss + Atten. Loss

Conducted Power Limit (5750 MHz-5825 MHz) = 1W (30dBm)

Method PM-G(Measurement using a Gated RF average power meter) is used.

Maximum Conducted Output Power

Test place : Ise EMC Lab. No.6 Measurement Room
Report No. : 11232955H
Date : April 19, 2016
Temperature / Humidity : 22deg. C / 44 % RH
Engineer : Hisayoshi Sato
Mode : Tx 11n-40 MCS 7

Antenna A

Tested Frequency [MHz]	Power Meter Reading [dBm]	Cable Loss [dB]	Atten. Loss [dB]	Duty Factor [dB]	Antenna Gain [dBi]	Result		Limit [dBm]	Margin [dB]
						[dBm]	[mW]		
5755	3.64	1.54	9.85	0.00	-	15.03	31.84	30.00	14.97
5795	3.36	1.54	9.85	0.00	-	14.75	29.85	30.00	15.25

Sample Calculation:

Power Result = Reading + Cable Loss + Atten. Loss

Conducted Power Limit (5750 MHz-5825 MHz) = 1W (30dBm)

Antenna B

Tested Frequency [MHz]	Power Meter Reading [dBm]	Cable Loss [dB]	Atten. Loss [dB]	Duty Factor [dB]	Antenna Gain [dBi]	Result		Limit [dBm]	Margin [dB]
						[dBm]	[mW]		
5755	3.93	1.54	9.70	0.00	-	15.17	32.89	30.00	14.83
5795	3.71	1.54	9.70	0.00	-	14.95	31.26	30.00	15.05

Sample Calculation:

Power Result = Reading + Cable Loss + Atten. Loss

Conducted Power Limit (5750 MHz-5825 MHz) = 1W (30dBm)

Method PM-G(Measurement using a Gated RF average power meter) is used.

UL Japan, Inc.

Ise EMC Lab.

4383-326 Asama-cho, Ise-shi, Mie-ken 516-0021 JAPAN

Telephone : +81 596 24 8999

Facsimile : +81 596 24 8124

Maximum Conducted Output Power

Test place : Ise EMC Lab. No.6 Measurement Room
Report No. : 11232955H
Date : April 19, 2016
Temperature / Humidity : 22deg. C / 44 % RH
Engineer : Hisayoshi Sato
Mode : Tx 11n-40 MCS 15

Antenna A+B

Tested Frequency [MHz]	Antenna			Result [dBm]	Limit [dBm]	Margin [dB]
	1 [mW]	2 [mW]	Sum [mW]			
5755	19.01	18.41	37.42	15.73	30.00	14.27
5795	19.36	18.45	37.81	15.78	30.00	14.22

Tested Frequency [MHz]	Antenna A					Antenna B				
	Power Meter Reading [dBm]	Cable Loss [dB]	Atten. Loss [dB]	Antenna Gain [dBi]	Result Power [dBm]	Power Meter Reading [dBm]	Cable Loss [dB]	Atten. Loss [dB]	Antenna Gain [dBi]	Result Power [dBm]
5755	1.40	1.54	9.85	-	12.79	1.41	1.54	9.70	-	12.65
5795	1.48	1.54	9.85	-	12.87	1.42	1.54	9.70	-	12.66

Sample Calculation:

Conducted Power Result = Reading + Cable Loss + Atten. Loss

Conducted Power Limit (5750 MHz-5825 MHz) = 1W (30dBm)

Method PM-G(Measurement using a Gated RF average power meter) is used.

Maximum Conducted Output Power

Test place : Ise EMC Lab. No.6 Measurement Room
Report No. : 11232955H
Date : April 19, 2016
Temperature / Humidity : 22deg. C / 44 % RH
Engineer : Hisayoshi Sato
Mode : Tx 11ac-40 VHT9

Antenna A

Tested Frequency [MHz]	Power Meter Reading [dBm]	Cable Loss [dB]	Atten. Loss [dB]	Duty Factor [dB]	Antenna Gain [dBi]	Result		Limit [dBm]	Margin [dB]
						[dBm]	[mW]		
5755	3.68	1.54	9.85	0.00	-	15.07	32.14	30.00	14.93
5795	3.45	1.54	9.85	0.00	-	14.84	30.48	30.00	15.16

Sample Calculation:

Power Result = Reading + Cable Loss + Atten. Loss

Conducted Power Limit (5750 MHz-5825 MHz) = 1W (30dBm)

Antenna B

Tested Frequency [MHz]	Power Meter Reading [dBm]	Cable Loss [dB]	Atten. Loss [dB]	Duty Factor [dB]	Antenna Gain [dBi]	Result		Limit [dBm]	Margin [dB]
						[dBm]	[mW]		
5755	4.01	1.54	9.70	0.00	-	15.25	33.50	30.00	14.75
5795	3.81	1.54	9.70	0.00	-	15.05	31.99	30.00	14.95

Sample Calculation:

Power Result = Reading + Cable Loss + Atten. Loss

Conducted Power Limit (5750 MHz-5825 MHz) = 1W (30dBm)

Method PM-G(Measurement using a Gated RF average power meter) is used.

Maximum Conducted Output Power

Test place : Ise EMC Lab. No.6 Measurement Room
Report No. : 11232955H
Date : April 19, 2016
Temperature / Humidity : 22deg. C / 44 % RH
Engineer : Hisayoshi Sato
Mode : Tx 11ac-40 VHT9

Antenna A+B

Tested Frequency [MHz]	Antenna			Result [dBm]	Limit [dBm]	Margin [dB]
	1 [mW]	2 [mW]	Sum [mW]			
5755	19.10	18.07	37.17	15.70	30.00	14.30
5795	19.54	18.75	38.29	15.83	30.00	14.17

Tested Frequency [MHz]	Antenna A					Antenna B				
	Power Meter Reading [dBm]	Cable Loss [dB]	Atten. Loss [dB]	Antenna Gain [dBi]	Result Power [dBm]	Power Meter Reading [dBm]	Cable Loss [dB]	Atten. Loss [dB]	Antenna Gain [dBi]	Result Power [dBm]
5755	1.42	1.54	9.85	-	12.81	1.33	1.54	9.70	-	12.57
5795	1.52	1.54	9.85	-	12.91	1.49	1.54	9.70	-	12.73

Sample Calculation:

Conducted Power Result = Reading + Cable Loss + Atten. Loss

Conducted Power Limit (5750 MHz-5825 MHz) = 1W (30dBm)

Method PM-G(Measurement using a Gated RF average power meter) is used.

Maximum Conducted Output Power

Test place : Ise EMC Lab. No.6 Measurement Room
 Report No. : 11232955H
 Date : April 19, 2016
 Temperature / Humidity : 22deg. C / 44 % RH
 Engineer : Hisayoshi Sato
 Mode : Tx 11ac-80 VHT9

Antenna A

Tested Frequency [MHz]	Power Meter Reading [dBm]	Cable Loss [dB]	Atten. Loss [dB]	Duty Factor [dB]	Antenna Gain [dBi]	Result		Limit [dBm]	Margin [dB]
						[dBm]	[mW]		
5775	1.61	1.54	9.85	0.00	-	13.00	19.95	30.00	17.00

Sample Calculation:

Power Result = Reading + Cable Loss + Atten. Loss

Conducted Power Limit (5750 MHz-5825 MHz) = 1W (30dBm)

Antenna B

Tested Frequency [MHz]	Power Meter Reading [dBm]	Cable Loss [dB]	Atten. Loss [dB]	Duty Factor [dB]	Antenna Gain [dBi]	Result		Limit [dBm]	Margin [dB]
						[dBm]	[mW]		
5775	1.64	1.54	9.70	0.00	-	12.88	19.41	30.00	17.12

Sample Calculation:

Power Result = Reading + Cable Loss + Atten. Loss

Conducted Power Limit (5750 MHz-5825 MHz) = 1W (30dBm)

Method PM-G(Measurement using a Gated RF average power meter) is used.

Maximum Conducted Output Power

Test place : Ise EMC Lab. No.6 Measurement Room
Report No. : 11232955H
Date : April 19, 2016
Temperature / Humidity : 22deg. C / 44 % RH
Engineer : Hisayoshi Sato
Mode : Tx 11ac-80 VHT9

Antenna A+B

Tested Frequency [MHz]	Antenna			Result [dBm]	Limit [dBm]	Margin [dB]
	1 [mW]	2 [mW]	Sum [mW]			
5775	10.19	9.40	19.58	12.92	30.00	17.08

Tested Frequency [MHz]	Antenna A					Antenna B				
	Power Meter Reading [dBm]	Cable Loss [dB]	Atten. Loss [dB]	Antenna Gain [dBi]	Result Power [dBm]	Power Meter Reading [dBm]	Cable Loss [dB]	Atten. Loss [dB]	Antenna Gain [dBi]	Result Power [dBm]
5775	-1.31	1.54	9.85	-	10.08	-1.51	1.54	9.70	-	9.73

Sample Calculation:

Conducted Power Result = Reading + Cable Loss + Atten. Loss

Conducted Power Limit (5750 MHz-5825 MHz) = 1W (30dBm)

Method PM-G(Measurement using a Gated RF average power meter) is used.

Maximum Conducted Output Power
(Reference data)

Test place : Ise EMC Lab. No.6 Measurement Room
Report No. : 11232955H
Date : April 15, 2016
Temperature/ Humidity : 24deg. C / 45 % RH
Engineer : Hisayoshi Sato
Mode : 11a Tx

5745MHz

Data Rate [Mbps]	Reading		Reading		Remark
	Antenna A		Antenna B		
	[dBm]	[mW]	[dBm]	[mW]	
6	3.69	2.34	3.80	2.40	*
9	3.55	2.26	3.67	2.33	
12	3.39	2.18	3.76	2.38	
18	3.51	2.24	3.77	2.38	
24	3.30	2.14	3.70	2.34	
36	3.48	2.23	3.71	2.35	
48	3.48	2.23	3.66	2.32	
54	3.46	2.22	3.76	2.38	

* Worst Rate

All comparisons were carried out on same frequency and measurement factors.

Maximum Conducted Output Power
(Reference data)

Test place : Ise EMC Lab. No.6 Measurement Room
Report No. : 11232955H
Date : April 15, 2016
Temperature/ Humidity : 24deg. C / 45 % RH
Engineer : Hisayoshi Sato
Mode : 11n-20 Tx

5745MHz

MCS Number	Reading		Reading		Result		Remark
	Antenna A		Antenna B		Antenna A + B		
	[dBm]	[mW]	[dBm]	[mW]	[dBm]	[mW]	
0	3.47	2.22	3.69	2.34	-	-	*SISO
1	3.40	2.19	3.68	2.33	-	-	
2	3.44	2.21	3.68	2.33	-	-	
3	3.37	2.17	3.67	2.33	-	-	
4	3.35	2.16	3.68	2.33	-	-	
5	3.42	2.20	3.67	2.33	-	-	
6	3.45	2.21	3.66	2.32	-	-	
7	3.36	2.17	3.66	2.32	-	-	
8	0.60	1.15	0.56	1.14	3.59	2.29	
9	0.62	1.15	0.60	1.15	3.62	2.30	
10	0.71	1.18	0.62	1.15	3.68	2.33	
11	0.78	1.20	0.68	1.17	3.74	2.37	
12	0.82	1.21	0.70	1.17	3.77	2.38	
13	0.87	1.22	0.72	1.18	3.81	2.40	
14	0.89	1.23	0.78	1.20	3.85	2.42	
15	0.90	1.23	0.91	1.23	3.92	2.46	*MIMO

* Worst MCS

All comparisons were carried out on same frequency and measurement factors.

Maximum Conducted Output Power
(Reference data)

Test place : Ise EMC Lab. No.6 Measurement Room
Report No. : 11232955H
Date : April 15, 2016
Temperature/ Humidity : 24deg. C / 45 % RH
Engineer : Hisayoshi Sato
Mode : 11ac-20 Tx

5745MHz

VHT Number	Reading		Reading		Result		Remark
	Antenna A		Antenna B		Antenna A + B		
	[dBm]	[mW]	[dBm]	[mW]	[dBm]	[mW]	
0	3.61	2.30	3.80	2.40	-	-	*SISO
1	3.36	2.17	3.78	2.39	-	-	
2	3.39	2.18	3.72	2.36	-	-	
3	3.34	2.16	3.65	2.32	-	-	
4	3.41	2.19	3.62	2.30	-	-	
5	3.44	2.21	3.64	2.31	-	-	
6	3.39	2.18	3.61	2.30	-	-	
7	3.43	2.20	3.59	2.29	-	-	
8	3.41	2.19	3.65	2.32	-	-	
0	0.38	1.09	0.60	1.15	3.50	2.24	
1	0.41	1.10	0.67	1.17	3.55	2.27	
2	0.47	1.11	0.73	1.18	3.61	2.30	
3	0.50	1.12	0.75	1.19	3.64	2.31	
4	0.53	1.13	0.82	1.21	3.69	2.34	
5	0.56	1.14	0.90	1.23	3.74	2.37	
6	0.59	1.15	0.92	1.24	3.77	2.38	
7	0.54	1.13	0.99	1.26	3.78	2.39	
8	0.90	1.23	0.91	1.23	3.92	2.46	*MIMO

* Worst VHT

All comparisons were carried out on same frequency and measurement factors.

Maximum Conducted Output Power
(Reference data)

Test place : Ise EMC Lab. No.6 Measurement Room
Report No. : 11232955H
Date : April 19, 2016
Temperature/ Humidity : 22deg. C / 44 % RH
Engineer : Hisayoshi Sato
Mode : 11n-40 Tx

5755MHz

MCS Number	Reading		Reading		Result		Remark
	Antenna A		Antenna B		Antenna A + B		
	[dBm]	[mW]	[dBm]	[mW]	[dBm]	[mW]	
0	3.41	2.19	3.79	2.39	-	-	
1	3.49	2.23	3.82	2.41	-	-	
2	3.55	2.26	3.80	2.40	-	-	
3	3.49	2.23	3.84	2.42	-	-	
4	3.52	2.25	3.86	2.43	-	-	
5	3.57	2.28	3.88	2.44	-	-	
6	3.59	2.29	3.91	2.46	-	-	
7	3.64	2.31	3.93	2.47	-	-	*SISO
8	0.72	1.18	0.72	1.18	3.73	2.36	
9	0.84	1.21	0.82	1.21	3.84	2.42	
10	0.95	1.24	0.92	1.24	3.95	2.48	
11	1.04	1.27	1.02	1.26	4.04	2.54	
12	1.12	1.29	1.16	1.31	4.15	2.60	
13	1.20	1.32	1.23	1.33	4.23	2.65	
14	1.31	1.35	1.29	1.35	4.31	2.70	
15	1.40	1.38	1.33	1.41	4.46	2.79	*MIMO

* Worst MCS

All comparisons were carried out on same frequency and measurement factors.

Maximum Conducted Output Power
(Reference data)

Test place : Ise EMC Lab. No.6 Measurement Room
Report No. : 11232955H
Date : April 19, 2016
Temperature/ Humidity : 22deg. C / 44 % RH
Engineer : Hisayoshi Sato
Mode : 11ac-40 Tx

5755MHz

VHT Number	Reading		Reading		Result		Remark
	Antenna A		Antenna B		Antenna A + B		
	[dBm]	[mW]	[dBm]	[mW]	[dBm]	[mW]	
0	3.27	2.12	3.64	2.31	-	-	
1	3.34	2.16	3.69	2.34	-	-	
2	3.41	2.19	3.73	2.36	-	-	
3	3.49	2.23	3.79	2.39	-	-	
4	3.55	2.26	3.82	2.41	-	-	
5	3.61	2.30	3.86	2.43	-	-	
6	3.64	2.31	3.91	2.46	-	-	
7	3.59	2.29	3.94	2.48	-	-	
8	3.66	2.32	3.99	2.51	-	-	
9	3.68	2.33	4.01	2.52	-	-	*SISO
0	0.65	1.16	1.11	0.66	2.60	1.82	
1	0.72	1.18	1.19	0.77	2.90	1.95	
2	0.79	1.20	1.24	0.84	3.10	2.04	
3	0.83	1.21	1.29	0.94	3.33	2.15	
4	0.92	1.24	1.30	1.06	3.61	2.30	
5	1.02	1.26	1.34	1.18	3.88	2.44	
6	1.19	1.32	1.40	1.24	4.07	2.56	
7	1.26	1.34	1.45	1.29	4.19	2.63	
8	1.35	1.36	1.57	1.37	4.37	2.73	
9	1.42	1.39	1.33	1.41	4.47	2.80	*MIMO

* Worst VHT

All comparisons were carried out on same frequency and measurement factors.

Maximum Conducted Output Power
(Reference data)

Test place : Ise EMC Lab. No.6 Measurement Room
Report No. : 11232955H
Date : April 19, 2016
Temperature/ Humidity : 22deg. C / 44 % RH
Engineer : Hisayoshi Sato
Mode : 11ac-80 Tx

5775MHz

VHT Number	Reading		Reading		Result		Remark
	Antenna A		Antenna B		Antenna A + B		
	[dBm]	[mW]	[dBm]	[mW]	[dBm]	[mW]	
0	1.23	1.33	1.22	1.32	-	-	
1	1.29	1.35	1.26	1.34	-	-	
2	1.34	1.36	1.30	1.35	-	-	
3	1.38	1.37	1.36	1.37	-	-	
4	1.43	1.39	1.40	1.38	-	-	
5	1.48	1.41	1.44	1.39	-	-	
6	1.52	1.42	1.48	1.41	-	-	
7	1.55	1.43	1.53	1.42	-	-	
8	1.59	1.44	1.58	1.44	-	-	
9	1.61	1.45	1.64	1.46	-	-	*SISO
0	-2.17	0.61	-2.30	0.59	0.78	1.20	
1	-2.11	0.62	-2.21	0.60	0.85	1.22	
2	-2.00	0.63	-2.13	0.61	0.95	1.24	
3	-1.92	0.64	-1.99	0.63	1.06	1.28	
4	-1.80	0.66	-1.89	0.65	1.17	1.31	
5	-1.73	0.67	-1.82	0.66	1.24	1.33	
6	-1.60	0.69	-1.75	0.67	1.34	1.36	
7	-1.53	0.70	-1.69	0.68	1.40	1.38	
8	-1.42	0.72	-1.62	0.69	1.49	1.41	
9	-1.31	0.74	-1.51	0.71	1.60	1.45	*MIMO

* Worst VHT

All comparisons were carried out on same frequency and measurement factors.

Maximum Conducted Output Power
(Reference data timed average power)

Test place : Ise EMC Lab. No.6 Measurement Room
Report No. : 11232955H
Date : April 15, 2016
Temperature / Humidity : 24deg. C / 45 % RH
Engineer : Hisayoshi Sato
Mode : Tx 11a 6Mbps

Antenna A

Tested Frequency [MHz]	Power Meter Reading [dBm]	Cable Loss [dB]	Atten. Loss [dB]	Duty Factor [dB]	Antenna Gain [dBi]	Result		Limit [dBm]	Margin [dB]
						[dBm]	[mW]		
5745	3.42	1.53	9.85	0.00	-	14.80	30.18	30.00	15.20
5785	3.43	1.54	9.85	0.00	-	14.82	30.33	30.00	15.18
5825	3.50	1.55	9.85	0.00	-	14.90	30.88	30.00	15.10

Sample Calculation:

Power Result = Reading + Cable Loss + Atten. Loss

Conducted Power Limit (5750 MHz-5825 MHz) = 1W (30dBm)

Antenna B

Tested Frequency [MHz]	Power Meter Reading [dBm]	Cable Loss [dB]	Atten. Loss [dB]	Duty Factor [dB]	Antenna Gain [dBi]	Result		Limit [dBm]	Margin [dB]
						[dBm]	[mW]		
5745	3.68	1.53	9.70	0.00	-	14.91	30.96	30.00	15.09
5785	3.45	1.54	9.70	0.00	-	14.69	29.44	30.00	15.31
5825	3.62	1.55	9.70	0.00	-	14.87	30.67	30.00	15.13

Sample Calculation:

Power Result = Reading + Cable Loss + Atten. Loss

Conducted Power Limit (5750 MHz-5825 MHz) = 1W (30dBm)

The test was performed with condition that obtained the maximum timed-average power for comparing power of Tune-up upper limit.

Maximum Conducted Output Power
(Reference data timed average power)

Test place : Ise EMC Lab. No.6 Measurement Room
Report No. : 11232955H
Date : April 15, 2016
Temperature / Humidity : 24deg. C / 45 % RH
Engineer : Hisayoshi Sato
Mode : Tx 11n-20 MCS 0

Antenna A

Tested Frequency [MHz]	Power Meter Reading [dBm]	Cable Loss [dB]	Atten. Loss [dB]	Duty Factor [dB]	Antenna Gain [dBi]	Result		Limit [dBm]	Margin [dB]
						[dBm]	[mW]		
5745	3.38	1.53	9.85	0.00	-	14.76	29.91	30.00	15.24
5785	3.40	1.54	9.85	0.00	-	14.79	30.12	30.00	15.21
5825	3.52	1.55	9.85	0.00	-	14.92	31.02	30.00	15.08

Sample Calculation:

Power Result = Reading + Cable Loss + Atten. Loss

Conducted Power Limit (5750 MHz-5825 MHz) = 1W (30dBm)

Antenna B

Tested Frequency [MHz]	Power Meter Reading [dBm]	Cable Loss [dB]	Atten. Loss [dB]	Duty Factor [dB]	Antenna Gain [dBi]	Result		Limit [dBm]	Margin [dB]
						[dBm]	[mW]		
5745	3.63	1.53	9.70	0.00	-	14.86	30.60	30.00	15.14
5785	3.49	1.54	9.70	0.00	-	14.73	29.71	30.00	15.27
5825	3.62	1.55	9.70	0.00	-	14.87	30.67	30.00	15.13

Sample Calculation:

Power Result = Reading + Cable Loss + Atten. Loss

Conducted Power Limit (5750 MHz-5825 MHz) = 1W (30dBm)

The test was performed with condition that obtained the maximum timed-average power for comparing power of Tune-up upper limit.

Maximum Conducted Output Power
(Reference data timed average power)

Test place : Ise EMC Lab. No.6 Measurement Room
Report No. : 11232955H
Date : April 19, 2016
Temperature / Humidity : 22deg. C / 44 % RH
Engineer : Hisayoshi Sato
Mode : Tx 11n-20 MCS 8

Antenna A+B

Tested Frequency [MHz]	Antenna			Result [dBm]	Limit [dBm]	Margin [dB]
	1 [mW]	2 [mW]	Sum [mW]			
5745	14.85	14.55	29.40	14.68	30.00	15.32
5785	14.58	14.32	28.90	14.61	30.00	15.39
5825	14.34	14.78	29.12	14.64	30.00	15.36

Tested Frequency [MHz]	Antenna A					Antenna B				
	Power Meter Reading [dBm]	Cable Loss [dB]	Atten. Loss [dB]	Antenna Gain [dBi]	Result Power [dBm]	Power Meter Reading [dBm]	Cable Loss [dB]	Atten. Loss [dB]	Antenna Gain [dBi]	Result Power [dBm]
	5745	0.34	1.53	9.85	-	11.72	0.40	1.53	9.70	-
5785	0.25	1.54	9.85	-	11.64	0.32	1.54	9.70	-	11.56
5825	0.17	1.55	9.85	-	11.57	0.45	1.55	9.70	-	11.70

Sample Calculation:

Power Result = Reading + Cable Loss + Atten. Loss

Conducted Power Limit (5750 MHz-5825 MHz) = 1W (30dBm)

The test was performed with condition that obtained the maximum timed-average power for comparing power of Tune-up upper limit.

Maximum Conducted Output Power
(Reference data timed average power)

Test place : Ise EMC Lab. No.6 Measurement Room
Report No. : 11232955H
Date : April 16, 2016
Temperature / Humidity : 24deg. C / 45 % RH
Engineer : Hisayoshi Sato
Mode : Tx 11ac-20 VHT0

Antenna A

Tested Frequency [MHz]	Power Meter Reading [dBm]	Cable Loss [dB]	Atten. Loss [dB]	Duty Factor [dB]	Antenna Gain [dBi]	Result		Limit [dBm]	Margin [dB]
						[dBm]	[mW]		
5745	3.50	1.53	9.85	0.00	-	14.88	30.74	30.00	15.12
5785	3.44	1.54	9.85	0.00	-	14.83	30.40	30.00	15.17
5825	3.48	1.55	9.85	0.00	-	14.88	30.74	30.00	15.12

Sample Calculation:
Power Result = Reading + Cable Loss + Atten. Loss
Conducted Power Limit (5750 MHz-5825 MHz) = 1W (30dBm)

Antenna B

Tested Frequency [MHz]	Power Meter Reading [dBm]	Cable Loss [dB]	Atten. Loss [dB]	Duty Factor [dB]	Antenna Gain [dBi]	Result		Limit [dBm]	Margin [dB]
						[dBm]	[mW]		
5745	3.58	1.53	9.70	0.00	-	14.81	30.25	30.00	15.19
5785	3.56	1.54	9.70	0.00	-	14.80	30.19	30.00	15.20
5825	3.61	1.55	9.70	0.00	-	14.86	30.59	30.00	15.14

Sample Calculation:
Power Result = Reading + Cable Loss + Atten. Loss
Conducted Power Limit (5750 MHz-5825 MHz) = 1W (30dBm)

The test was performed with condition that obtained the maximum timed-average power for comparing power of Tune-up upper limit.

Maximum Conducted Output Power
(Reference data timed average power)

Test place : Ise EMC Lab. No.6 Measurement Room
Report No. : 11232955H
Date : April 19, 2016
Temperature / Humidity : 22deg. C / 44 % RH
Engineer : Hisayoshi Sato
Mode : Tx 11ac-20 VHT0

Antenna A+B

Tested Frequency [MHz]	Antenna			Result [dBm]	Limit [dBm]	Margin [dB]
	1 [mW]	2 [mW]	Sum [mW]			
5745	14.28	14.92	29.20	14.65	30.00	15.35
5785	14.42	14.22	28.64	14.57	30.00	15.43
5825	14.51	14.21	28.72	14.58	30.00	15.42

Tested Frequency [MHz]	Antenna A					Antenna B				
	Power Meter Reading [dBm]	Cable Loss [dB]	Atten. Loss [dB]	Antenna Gain [dBi]	Result Power [dBm]	Power Meter Reading [dBm]	Cable Loss [dB]	Atten. Loss [dB]	Antenna Gain [dBi]	Result Power [dBm]
5745	0.17	1.53	9.85	-	11.55	0.51	1.53	9.70	-	11.74
5785	0.20	1.54	9.85	-	11.59	0.29	1.54	9.70	-	11.53
5825	0.22	1.55	9.85	-	11.62	0.28	1.55	9.70	-	11.53

Sample Calculation:

Power Result = Reading + Cable Loss + Atten. Loss

e.i.r.p Power Limit (5150 MHz-5250 MHz) = 200 mW (23.01dBm)

Conducted Power Limit (5750 MHz-5825 MHz) = 1W (30dBm)

The test was performed with condition that obtained the maximum timed-average power for comparing power of Tune-up upper limit.

Maximum Conducted Output Power
(Reference data timed average power)

Test place : Ise EMC Lab. No.6 Measurement Room
Report No. : 11232955H
Date : April 19, 2016
Temperature / Humidity : 22deg. C / 44 % RH
Engineer : Hisayoshi Sato
Mode : Tx 11n-40 MCS 0

Antenna A

Tested Frequency [MHz]	Power Meter Reading [dBm]	Cable Loss [dB]	Atten. Loss [dB]	Duty Factor [dB]	Antenna Gain [dBi]	Result		Limit [dBm]	Margin [dB]
						[dBm]	[mW]		
5755	3.30	1.54	9.85	0.00	-	14.69	29.44	30.00	15.31
5795	3.12	1.54	9.85	0.00	-	14.51	28.25	30.00	15.49

Sample Calculation:

Power Result = Reading + Cable Loss + Atten. Loss

Conducted Power Limit (5750 MHz-5825 MHz) = 1W (30dBm)

Antenna B

Tested Frequency [MHz]	Power Meter Reading [dBm]	Cable Loss [dB]	Atten. Loss [dB]	Duty Factor [dB]	Antenna Gain [dBi]	Result		Limit [dBm]	Margin [dB]
						[dBm]	[mW]		
5755	3.59	1.54	9.70	0.00	-	14.83	30.41	30.00	15.17
5795	3.29	1.54	9.70	0.00	-	14.53	28.38	30.00	15.47

Sample Calculation:

Power Result = Reading + Cable Loss + Atten. Loss

Conducted Power Limit (5750 MHz-5825 MHz) = 1W (30dBm)

The test was performed with condition that obtained the maximum timed-average power for comparing power of Tune-up upper limit.

Maximum Conducted Output Power
(Reference data timed average power)

Test place : Ise EMC Lab. No.6 Measurement Room
Report No. : 11232955H
Date : April 19, 2016
Temperature / Humidity : 22deg. C / 44 % RH
Engineer : Hisayoshi Sato
Mode : Tx 11n-40 MCS 8

Antenna A+B

Tested Frequency [MHz]	Antenna			Result [dBm]	Limit [dBm]	Margin [dB]
	1 [mW]	2 [mW]	Sum [mW]			
5755	15.38	14.66	30.04	14.78	30.00	15.22
5795	15.42	15.31	30.73	14.88	30.00	15.12

Tested Frequency [MHz]	Antenna A					Antenna B				
	Power Meter Reading [dBm]	Cable Loss [dB]	Atten. Loss [dB]	Antenna Gain [dBi]	Result Power [dBm]	Power Meter Reading [dBm]	Cable Loss [dB]	Atten. Loss [dB]	Antenna Gain [dBi]	Result Power [dBm]
5755	0.48	1.54	9.85	-	11.87	0.42	1.54	9.70	-	11.66
5795	0.49	1.54	9.85	-	11.88	0.61	1.54	9.70	-	11.85

Sample Calculation:

Power Result = Reading + Cable Loss + Atten. Loss

Conducted Power Limit (5750 MHz-5825 MHz) = 1W (30dBm)

The test was performed with condition that obtained the maximum timed-average power for comparing power of Tune-up upper limit.

UL Japan, Inc.

Ise EMC Lab.

4383-326 Asama-cho, Ise-shi, Mie-ken 516-0021 JAPAN

Telephone : +81 596 24 8999

Facsimile : +81 596 24 8124

Maximum Conducted Output Power
(Reference data timed average power)

Test place Ise EMC Lab. No.6 Measurement Room
Report No. 11232955H
Date April 19, 2016
Temperature / Humidity 22deg. C / 44 % RH
Engineer Hisayoshi Sato
Mode Tx 11ac-40 VHT0

Antenna A

Tested Frequency [MHz]	Power Meter Reading [dBm]	Cable Loss [dB]	Atten. Loss [dB]	Duty Factor [dB]	Antenna Gain [dBi]	Result		Limit [dBm]	Margin [dB]
						[dBm]	[mW]		
5755	3.17	1.54	9.85	0.00	-	14.56	28.58	30.00	15.44
5795	3.14	1.54	9.85	0.00	-	14.53	28.38	30.00	15.47

Sample Calculation:

Power Result = Reading + Cable Loss + Atten. Loss

Conducted Power Limit (5750 MHz-5825 MHz) = 1W (30dBm)

Antenna B

Tested Frequency [MHz]	Power Meter Reading [dBm]	Cable Loss [dB]	Atten. Loss [dB]	Duty Factor [dB]	Antenna Gain [dBi]	Result		Limit [dBm]	Margin [dB]
						[dBm]	[mW]		
5755	3.53	1.54	9.70	0.00	-	14.77	29.99	30.00	15.23
5795	3.31	1.54	9.70	0.00	-	14.55	28.51	30.00	15.45

Sample Calculation:

Power Result = Reading + Cable Loss + Atten. Loss

Conducted Power Limit (5750 MHz-5825 MHz) = 1W (30dBm)

The test was performed with condition that obtained the maximum timed-average power for comparing power of Tune-up upper limit.

Maximum Conducted Output Power
(Reference data timed average power)

Test place : Ise EMC Lab. No.6 Measurement Room
Report No. : 11232955H
Date : April 19, 2016
Temperature / Humidity : 22deg. C / 44 % RH
Engineer : Hisayoshi Sato
Mode : Tx 11ac-40 VHT0

Antenna A+B

Tested Frequency [MHz]	Antenna			Result [dBm]	Limit [dBm]	Margin [dB]
	1 [mW]	2 [mW]	Sum [mW]			
5755	15.21	14.49	29.69	14.73	30.00	15.27
5795	15.35	15.38	30.73	14.88	30.00	15.12

Tested Frequency [MHz]	Antenna A					Antenna B				
	Power Meter Reading [dBm]	Cable Loss [dB]	Atten. Loss [dB]	Antenna Gain [dBi]	Result Power [dBm]	Power Meter Reading [dBm]	Cable Loss [dB]	Atten. Loss [dB]	Antenna Gain [dBi]	Result Power [dBm]
5755	0.43	1.54	9.85	-	11.82	0.37	1.54	9.70	-	11.61
5795	0.47	1.54	9.85	-	11.86	0.63	1.54	9.70	-	11.87

Sample Calculation:

Power Result = Reading + Cable Loss + Atten. Loss

Conducted Power Limit (5750 MHz-5825 MHz) = 1W (30dBm)

The test was performed with condition that obtained the maximum timed-average power for comparing power of Tune-up upper limit.

Maximum Conducted Output Power
(Reference data timed average power)

Test place : Ise EMC Lab. No.6 Measurement Room
Report No. : 11232955H
Date : April 19, 2016
Temperature / Humidity : 22deg. C / 44 % RH
Engineer : Hisayoshi Sato
Mode : Tx 11ac-80 VHT0

Antenna A

Tested Frequency [MHz]	Power Meter Reading [dBm]	Cable Loss [dB]	Atten. Loss [dB]	Duty Factor [dB]	Antenna Gain [dBi]	Result		Limit [dBm]	Margin [dB]
						[dBm]	[mW]		
5775	0.90	1.54	9.85	0.00	-	12.29	16.94	30.00	17.71

Sample Calculation:

Power Result = Reading + Cable Loss + Atten. Loss
Conducted Power Limit (5750 MHz-5825 MHz) = 1W (30dBm)

Antenna B

Tested Frequency [MHz]	Power Meter Reading [dBm]	Cable Loss [dB]	Atten. Loss [dB]	Duty Factor [dB]	Antenna Gain [dBi]	Result		Limit [dBm]	Margin [dB]
						[dBm]	[mW]		
5775	0.93	1.54	9.70	0.00	-	12.17	16.48	30.00	17.83

Sample Calculation:

Power Result = Reading + Cable Loss + Atten. Loss
Conducted Power Limit (5750 MHz-5825 MHz) = 1W (30dBm)

The test was performed with condition that obtained the maximum timed-average power for comparing power of Tune-up upper limit.

Maximum Conducted Output Power
(Reference data timed average power)

Test place : Ise EMC Lab. No.6 Measurement Room
Report No. : 11232955H
Date : April 19, 2016
Temperature / Humidity : 22deg. C / 44 % RH
Engineer : Hisayoshi Sato
Mode : Tx 11ac-80 VHT0

Antenna A+B

Tested Frequency [MHz]	Antenna			Result [dBm]	Limit [dBm]	Margin [dB]
	1 [mW]	2 [mW]	Sum [mW]			
5775	7.60	7.11	14.72	11.68	30.00	18.32

Tested Frequency [MHz]	Antenna A					Antenna B				
	Power Meter Reading [dBm]	Cable [dB]	Atten. Loss [dB]	Antenna Gain [dBi]	Result Power [dBm]	Power Meter Reading [dBm]	Cable Loss [dB]	Atten. Loss [dB]	Antenna Gain [dBi]	Result Power [dBm]
5775	-2.58	1.54	9.85	-	8.81	-2.72	1.54	9.70	-	8.52

Sample Calculation:

Conducted Power Result = Reading + Cable Loss + Atten. Loss

Conducted Power Limit (5750 MHz-5825 MHz) = 1W (30dBm)

The test was performed with condition that obtained the maximum timed-average power for comparing power of Tune-up upper limit.

Burst rate confirmation

Test place	Ise EMC Lab. No.3 Measurement Room
Report No.	11232955H
Date	April 20, 2016
Temperature / Humidity	23deg. C / 35 % RH
Engineer	Yutaka Yoshida

11a 6Mbps

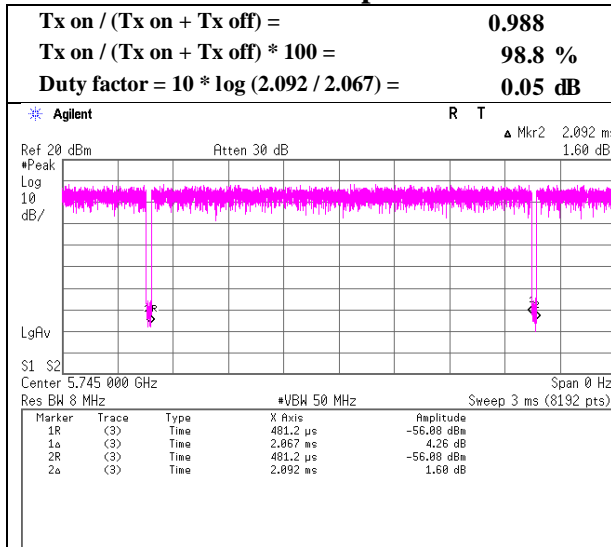

11ac-20 VHT8 (Long GI)

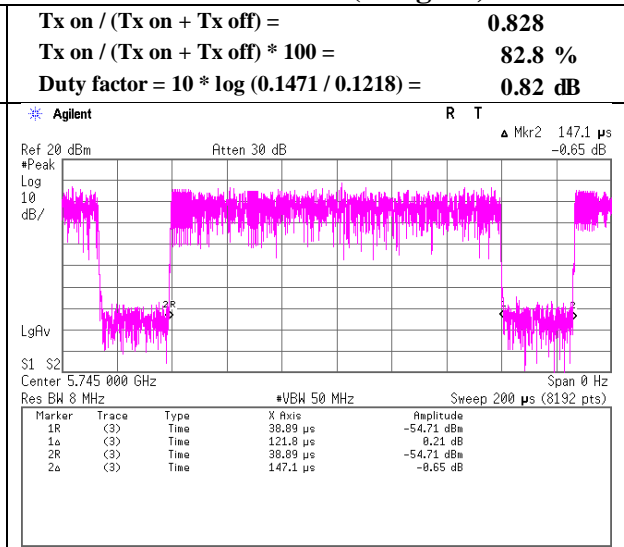

11ac-40 VHT9 (Long GI)

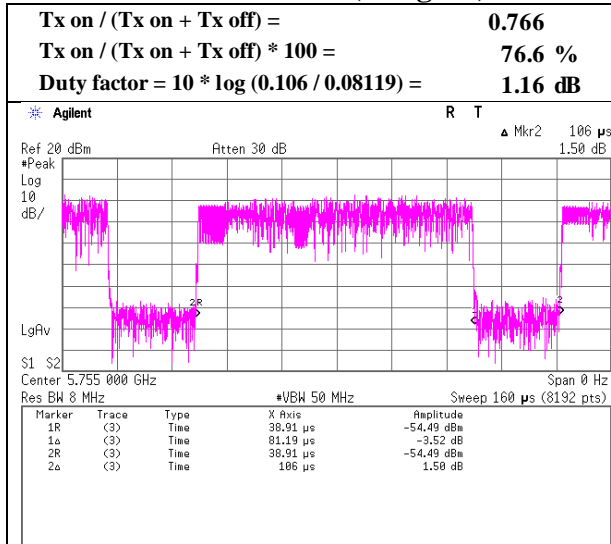

11ac-80 VHT9 (Long GI)

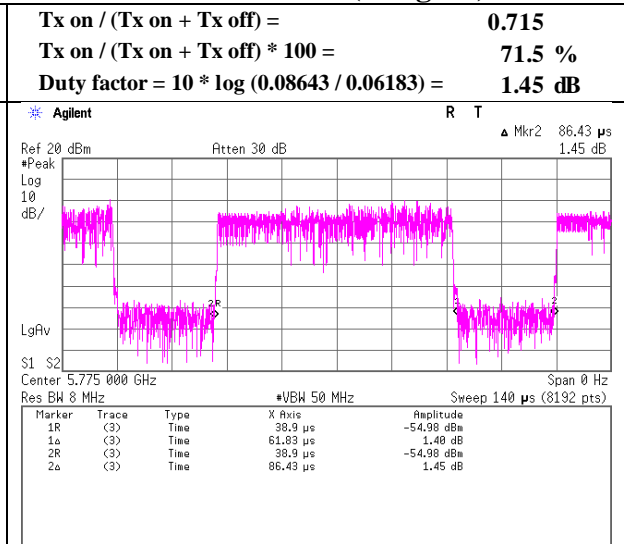

Maximum Power Spectral Density

Test place : Ise EMC Lab. No.3 Measurement Room
Report No. : 11232955H
Date : April 20, 2016
Temperature / Humidity : 23deg. C / 35 % RH
Engineer : Yutaka Yoshida
Mode : Tx 11a

Antenna A

Applied limit: 15.407, mobile and portable client device

Tested Frequency [MHz]	PSD Reading [dBm /MHz]	Cable Loss [dB]	Atten. Loss [dB]	Duty Factor [dB]	Antenna Gain [dBi]	RBW Correction Factor [dB]	PSD (Conducted)			PSD (e.i.r.p.)		
							Result [dBm /MHz]	Limit [dBm /MHz]	Margin [dB]	Result [dBm /MHz]	Limit [dBm /MHz]	Margin [dB]
5745	-10.78	1.53	9.85	0.05	2.30	0.27	0.92	30.00	29.08	3.22	36.00	32.78
5785	-11.10	1.54	9.85	0.05	2.30	0.27	0.61	30.00	29.39	2.91	36.00	33.09
5825	-10.66	1.55	9.85	0.05	2.30	0.27	1.06	30.00	28.94	3.36	36.00	32.64

Sample Calculation:

PSD: Power Spectral Density

The PSD within 5725 MHz to 5825 MHz are based on any 500 kHz band.

RBW Correction Factor = $10 * \log(\text{Specified bandwidth} / \text{Measured bandwidth})$

PSD Result (Conducted) = Reading + Cable Loss (including the cable(s) customer supplied) + Atten. Loss + Duty Factor + RBW Correction Factor

PSD Result (e.i.r.p.) = Conducted PSD Result + Antenna Gain

The conducted PSD limit was reduced by the amount in dB that the directional gain of the antenna exceeds 6 dBi. (All frequencies for FCC, 5725 MHz-5850 MHz for IC)

Antenna B

Applied limit: 15.407, mobile and portable client device

Tested Frequency [MHz]	PSD Reading [dBm /MHz]	Cable Loss [dB]	Atten. Loss [dB]	Duty Factor [dB]	Antenna Gain [dBi]	RBW Correction Factor [dB]	PSD (Conducted)			PSD (e.i.r.p.)		
							Result [dBm /MHz]	Limit [dBm /MHz]	Margin [dB]	Result [dBm /MHz]	Limit [dBm /MHz]	Margin [dB]
5745	-10.72	1.53	9.85	0.05	1.87	0.27	0.98	30.00	29.02	2.85	36.00	33.15
5785	-10.99	1.54	9.85	0.05	1.87	0.27	0.72	30.00	29.28	2.59	36.00	33.41
5825	-10.95	1.55	9.85	0.05	1.87	0.27	0.77	30.00	29.23	2.64	36.00	33.36

Sample Calculation:

PSD: Power Spectral Density

The PSD within 5725 MHz to 5825 MHz are based on any 500 kHz band.

RBW Correction Factor = $10 * \log(\text{Specified bandwidth} / \text{Measured bandwidth})$

PSD Result (Conducted) = Reading + Cable Loss (including the cable(s) customer supplied) + Atten. Loss + Duty Factor + RBW Correction Factor

PSD Result (e.i.r.p.) = Conducted PSD Result + Antenna Gain

The conducted PSD limit was reduced by the amount in dB that the directional gain of the antenna exceeds 6 dBi. (All frequencies for FCC, 5725 MHz-5850 MHz for IC)

Maximum Power Spectral Density

Test place : Ise EMC Lab. No.3 Measurement Room
Report No. : 11232955H
Date : April 20, 2016
Temperature / Humidity : 23deg. C / 35 % RH
Engineer : Yutaka Yoshida
Mode : Tx 11ac-20

Applied limit: 15.407, mobile and portable client device

Tested Frequency [MHz]	PSD (Conducted)						PSD (e.i.r.p.)					
	Antenna			Result [dBm/MHz]	Limit [dBm/MHz]	Margin [dB]	Antenna			Result [dBm/MHz]	Limit [dBm/MHz]	Margin [dB]
	1 [mW/MHz]	2 [mW/MHz]	Sum [mW/MHz]				1 [mW/MHz]	2 [mW/MHz]	Sum [mW/MHz]			
5745	0.78	0.82	1.60	2.03	30.00	27.97	1.32	1.39	2.71	4.33	36.00	31.67
5785	0.79	0.77	1.56	1.92	30.00	28.08	1.34	1.30	2.64	4.22	36.00	31.78
5825	0.81	0.71	1.52	1.83	30.00	28.17	1.38	1.21	2.59	4.13	36.00	31.87

Tested Frequency [MHz]	Duty Factor [dB]	RBW Correction Factor [dB]	Antenna A					Antenna B						
			PSD Reading [dBm/MHz]	Cable Loss [dB]	Atten. Loss [dB]	Antenna Gain [dBi]	PSD Result Cond. [dBm/MHz]	e.i.r.p. [dBm/MHz]	PSD Reading [dBm/MHz]	Cable Loss [dB]	Atten. Loss [dB]	Antenna Gain [dBi]	PSD Result Cond. [dBm/MHz]	e.i.r.p. [dBm/MHz]
5745	0.82	0.27	-13.57	1.53	9.85	2.30	-1.11	1.19	-13.33	1.53	9.85	2.30	-0.86	1.44
5785	0.82	0.27	-13.50	1.54	9.85	2.30	-1.02	1.28	-13.63	1.54	9.85	2.30	-1.15	1.15
5825	0.82	0.27	-13.39	1.55	9.85	2.30	-0.91	1.39	-13.96	1.55	9.85	2.30	-1.48	0.82

Sample Calculation:

PSD: Power Spectral Density

The PSD within 5725 MHz to 5825 MHz are based on any 500 kHz band.

RBW Correction Factor = $10 * \log(\text{Specified bandwidth} / \text{Measured bandwidth})$

PSD Result (Conducted) = Reading + Cable Loss (including the cable(s) customer supplied) + Atten. Loss + Duty Factor + RBW Correction Factor

PSD Result (e.i.r.p.) = Conducted PSD Result + Antenna Gain

Antenna directional Gain = $G_{ANT MAX} + 10 \log(N_{ANT} / N_{SS})$

The conducted PSD limit was reduced by the amount in dB that the directional gain of the antenna exceeds 6 dBi. (All frequencies for FCC, 5725 MHz-5850 MHz for IC)

UL Japan, Inc.

Ise EMC Lab.

4383-326 Asama-cho, Ise-shi, Mie-ken 516-0021 JAPAN

Telephone : +81 596 24 8999

Facsimile : +81 596 24 8124

Maximum Power Spectral Density

Test place : Ise EMC Lab. No.3 Measurement Room
Report No. : 11232955H
Date : April 20, 2016
Temperature / Humidity : 23deg. C / 35 % RH
Engineer : Yutaka Yoshida
Mode : Tx 11ac-40

Applied limit: 15.407, mobile and portable client device

Tested Frequency [MHz]	PSD (Conducted)						PSD (e.i.r.p.)					
	Antenna			Result [dBm/MHz]	Limit [dBm/MHz]	Margin [dB]	Antenna			Result [dBm/MHz]	Limit [dBm/MHz]	Margin [dB]
	1 [mW/MHz]	2 [mW/MHz]	Sum [mW/MHz]				1 [mW/MHz]	2 [mW/MHz]	Sum [mW/MHz]			
5755	0.56	0.51	1.07	0.29	30.00	29.71	0.95	0.87	1.81	2.59	36.00	33.41
5795	0.62	0.52	1.14	0.56	30.00	29.44	1.05	0.89	1.93	2.86	36.00	33.14

Tested Frequency [MHz]	Duty Factor [dB]	RBW Correction Factor [dB]	Antenna A				Antenna B				PSD Result			
			PSD Reading [dBm/MHz]	Cable Loss [dB]	Atten. Loss [dB]	Antenna Gain [dBi]	PSD Reading [dBm/MHz]	Cable Loss [dB]	Atten. Loss [dB]	Antenna Gain [dBi]	Cond. [dBm/MHz]	e.i.r.p. [dBm/MHz]		
5755	1.16	0.27	-15.36	1.54	9.85	2.30	-2.54	-0.24	-15.74	1.54	9.85	2.30	-2.92	-0.62
5795	1.16	0.27	-14.93	1.54	9.85	2.30	-2.10	0.20	-15.65	1.54	9.85	2.30	-2.83	-0.53

Sample Calculation:

PSD: Power Spectral Density

The PSD within 5725 MHz to 5825 MHz are based on any 500 kHz band.

RBW Correction Factor = $10 * \log(\text{Specified bandwidth} / \text{Measured bandwidth})$

PSD Result (Conducted) = Reading + Cable Loss (including the cable(s) customer supplied) + Atten. Loss + Duty Factor + RBW Correction Factor

PSD Result (e.i.r.p.) = Conducted PSD Result + Antenna Gain

Antenna directional Gain = $G_{ANT MAX} + 10 \log(N_{ANT} / N_{SS})$

The conducted PSD limit was reduced by the amount in dB that the directional gain of the antenna exceeds 6 dBi. (All frequencies for FCC, 5725 MHz-5850 MHz for IC)

Maximum Power Spectral Density

Test place : Ise EMC Lab. No.3 Measurement Room
Report No. : 11232955H
Date : April 20, 2016
Temperature / Humidity : 23deg. C / 35 % RH
Engineer : Yutaka Yoshida
Mode : Tx 11ac-80

Applied limit: 15.407, mobile and portable client device

Tested Frequency [MHz]	PSD (Conducted)						PSD (e.i.r.p.)					
	Antenna			Result	Limit	Margin	Antenna			Result	Limit	Margin
	1	2	Sum				1	2	Sum			
5775	0.17	0.16	0.33	-4.81	30.00	34.81	0.29	0.27	0.56	-2.51	36.00	38.51

Tested Frequency [MHz]	Duty Factor [dB]	RBW Correction Factor [dB]	Antenna A					Antenna B						
			PSD Reading	Cable Loss	Atten. Loss	Antenna Gain	PSD Result Cond.	e.i.r.p.	PSD Reading	Cable Loss	Atten. Loss	Antenna Gain	PSD Result Cond.	e.i.r.p.
			[dBm/MHz]	[dB]	[dB]	[dBi]	[dBm/MHz]	[dBm/MHz]	[dBm/MHz]	[dB]	[dB]	[dBi]	[dBm/MHz]	[dBm/MHz]
5775	1.45	0.27	-20.80	1.54	9.85	2.30	-7.69	-5.39	-21.07	1.54	9.85	2.30	-7.96	-5.66

Sample Calculation:

PSD: Power Spectral Density

The PSD within 5725 MHz to 5825 MHz are based on any 500 kHz band.

RBW Correction Factor = $10 * \log(\text{Specified bandwidth} / \text{Measured bandwidth})$

PSD Result (Conducted) = Reading + Cable Loss (including the cable(s) customer supplied) + Atten. Loss + Duty Factor + RBW Correction Factor

PSD Result (e.i.r.p.) = Conducted PSD Result + Antenna Gain

Antenna directional Gain = $G_{\text{ANT MAX}} + 10 \log(N_{\text{ANT}} / N_{\text{SS}})$

The conducted PSD limit was reduced by the amount in dB that the directional gain of the antenna exceeds 6 dBi. (All frequencies for FCC, 5725 MHz-5850 MHz for IC)

Maximum Power Spectral Density

Test place	Ise EMC Lab. No.3 Measurement Room
Report No.	11232955H
Date	April 20, 2016
Temperature / Humidity	23deg. C / 35 % RH
Engineer	Yutaka Yoshida
Mode	Tx 11a

11a, Antenna A

11a, Antenna B

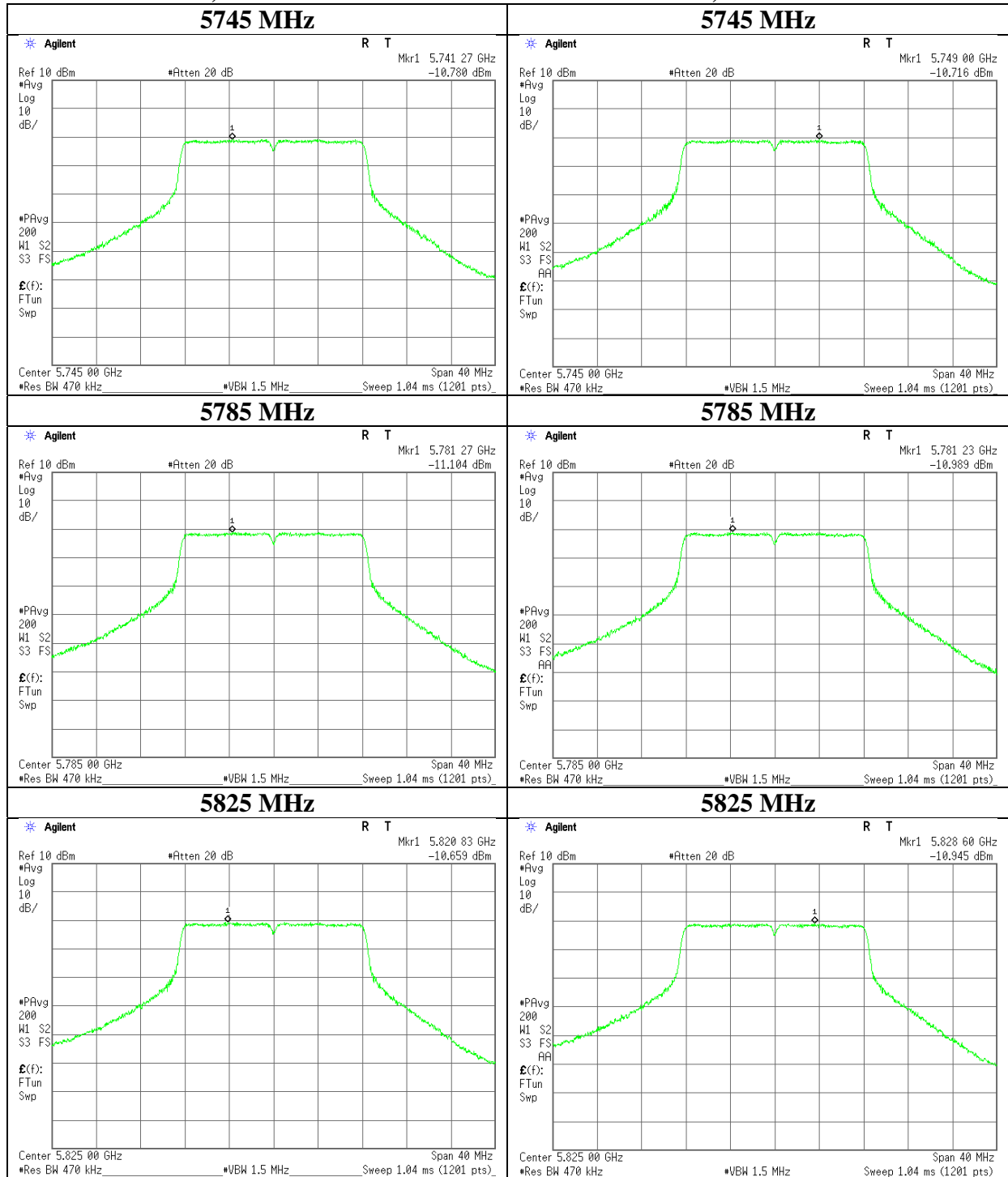

UL Japan, Inc.

Ise EMC Lab.

4383-326 Asama-cho, Ise-shi, Mie-ken 516-0021 JAPAN

Telephone : +81 596 24 8999

Facsimile : +81 596 24 8124

Maximum Power Spectral Density

Test place	Ise EMC Lab. No.3 Measurement Room
Report No.	11232955H
Date	April 20, 2016
Temperature / Humidity	23deg. C / 35 % RH
Engineer	Yutaka Yoshida
Mode	Tx 11ac-20

11ac-20, Antenna A

11ac-20, Antenna B

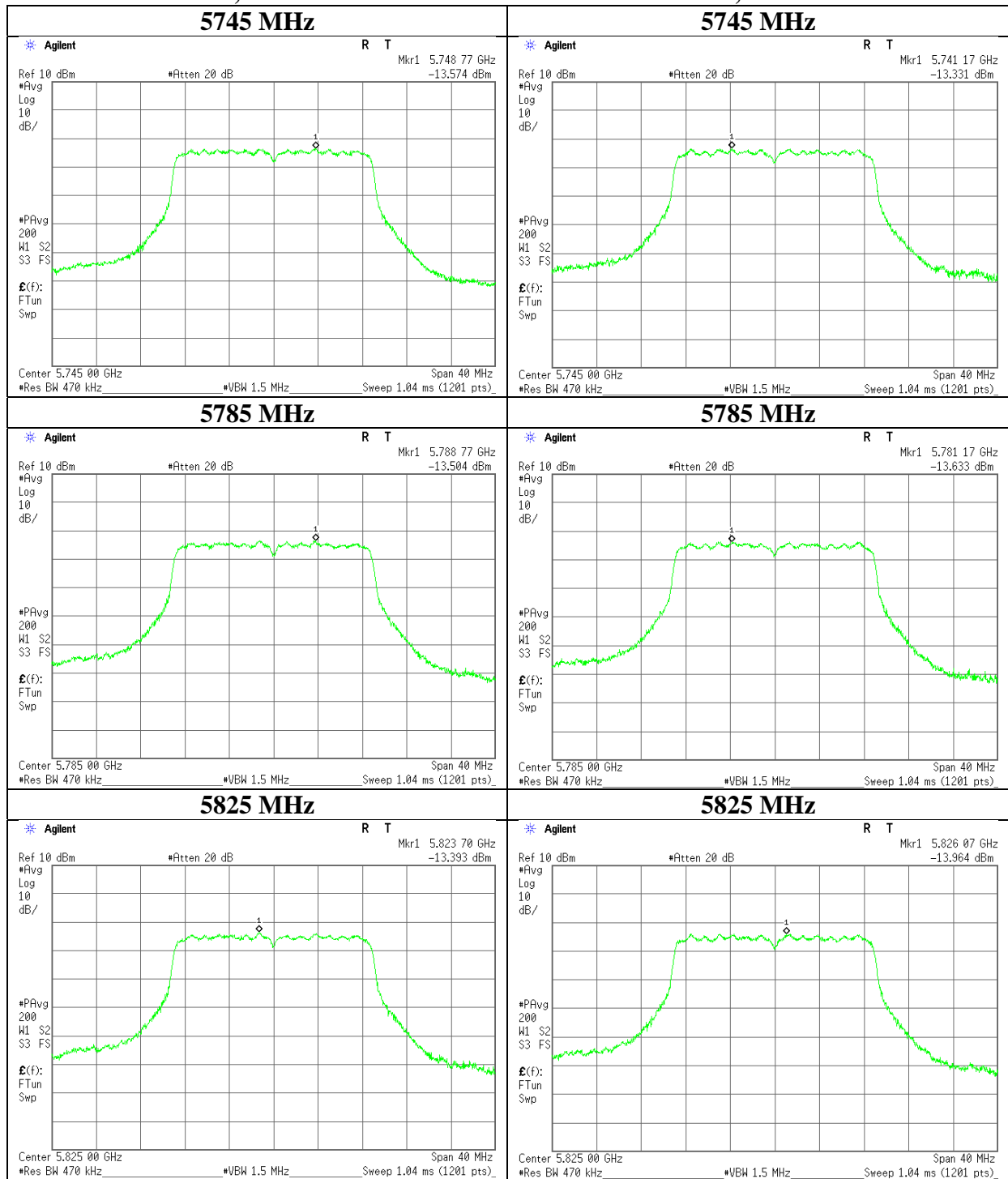

Maximum Power Spectral Density

Test place	Ise EMC Lab. No.3 Measurement Room
Report No.	11232955H
Date	April 20, 2016
Temperature / Humidity	23deg. C / 35 % RH
Engineer	Yutaka Yoshida
Mode	Tx 11ac-40

11ac-40, Antenna A

11ac-40, Antenna B

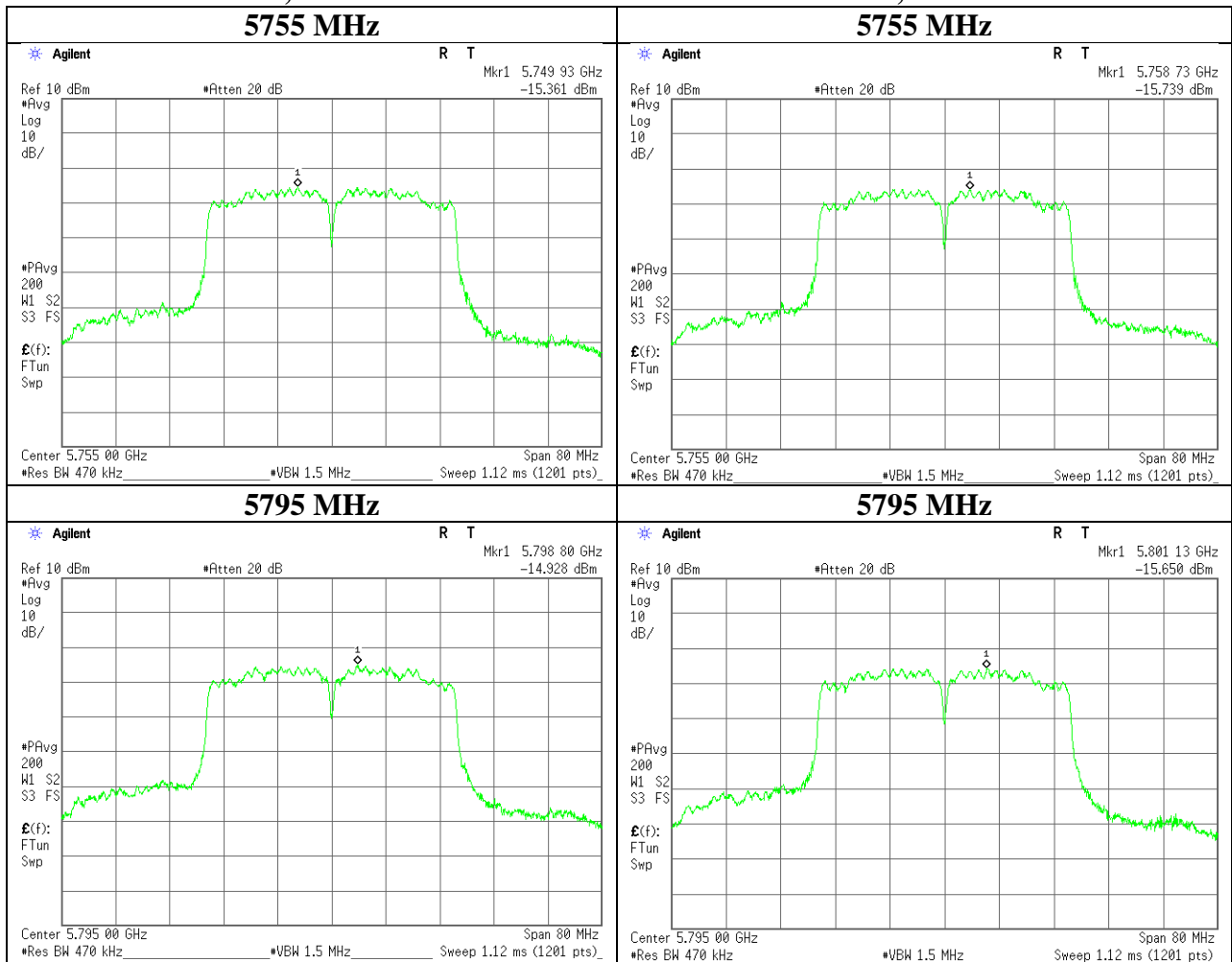

UL Japan, Inc.

Ise EMC Lab.

4383-326 Asama-cho, Ise-shi, Mie-ken 516-0021 JAPAN

Telephone : +81 596 24 8999

Facsimile : +81 596 24 8124

Maximum Power Spectral Density

Test place	Ise EMC Lab. No.3 Measurement Room
Report No.	11232955H
Date	April 20, 2016
Temperature / Humidity	23deg. C / 35 % RH
Engineer	Yutaka Yoshida
Mode	Tx 11ac-80

11ac-80, Antenna A

5775 MHz

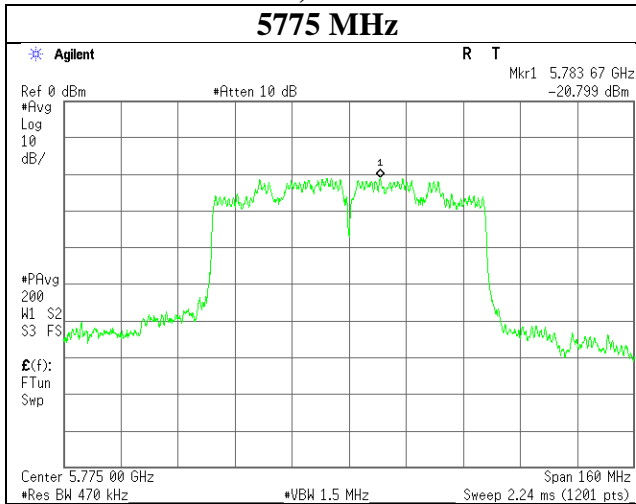

11ac-80, Antenna B

5775 MHz

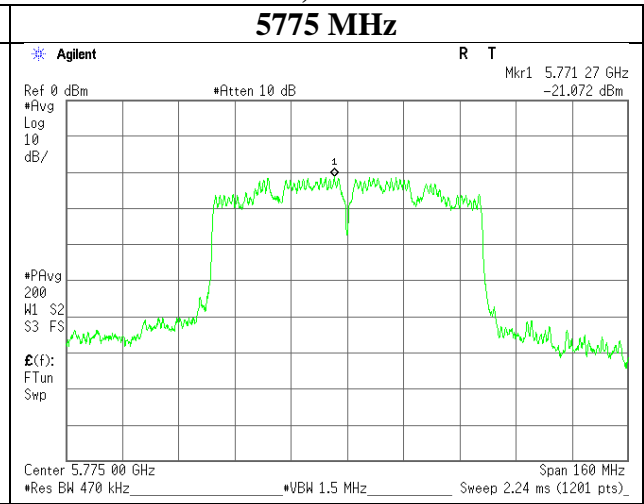

UL Japan, Inc.

Ise EMC Lab.

4383-326 Asama-cho, Ise-shi, Mie-ken 516-0021 JAPAN

Telephone : +81 596 24 8999

Facsimile : +81 596 24 8124

Radiated Spurious Emission

Test place	Ise EMC Lab.	
Report No.	11232955H	
Semi Anechoic Chamber	No.1	No.1
Date	April 21, 2016	April 20, 2016
Temperature / Humidity	23deg. C / 45 % RH	23deg. C / 45 % RH
Engineer	Tomohisa Nakagawa (1-26.5GHz)	Tomohisa Nakagawa (Above 26.5GHz)
Mode	Tx 11ac-20 5745 MHz	

Polarity	Frequency [MHz]	Detector	Reading [dBuV]	Ant.Fac. [dB/m]	Loss [dB]	Gain [dB]	Duty Factor [dB]	Result [dBuV/m]	Limit [dBuV/m]	Margin [dB]	Remark
Hori	5650.000	PK	47.9	32.8	6.5	35.4		51.8	68.2	16.4	
Hori	5700.000	PK	52.8	32.8	6.5	35.5		56.6	105.2	48.6	
Hori	5720.000	PK	64.3	32.9	6.5	35.5		68.2	110.8	42.6	
Hori	5725.000	PK	69.9	32.9	6.5	35.5		73.8	122.2	48.4	
Hori	11490.000	PK	45.0	40.5	-1.4	35.2		48.9	73.9	25.0	
Hori	17235.000	PK	45.3	42.9	0.1	35.0		53.3	73.9	20.6	
Hori	22980.000	PK	49.1	37.9	-0.6	34.7		51.7	73.9	22.2	
Hori	11490.000	AV	38.4	40.5	-1.4	35.2	0.8	43.1	53.9	10.8	
Hori	17235.000	AV	38.3	42.9	0.1	35.0	0.8	47.1	53.9	6.8	
Hori	22980.000	AV	42.3	37.9	-0.6	34.7	0.8	45.7	53.9	8.2	
Vert	5650.000	PK	48.7	32.8	6.5	35.4		52.6	68.2	15.6	
Vert	5700.000	PK	54.7	32.8	6.5	35.5		58.5	105.2	46.7	
Vert	5720.000	PK	64.5	32.9	6.5	35.5		68.4	110.8	42.4	
Vert	5725.000	PK	70.8	32.9	6.5	35.5		74.7	122.2	47.5	
Vert	11490.000	PK	46.5	40.5	-1.4	35.2		50.4	73.9	23.5	
Vert	17235.000	PK	44.6	42.9	0.1	35.0		52.6	73.9	21.3	
Vert	22980.000	PK	49.4	37.9	-0.6	34.7		52.0	73.9	21.9	
Vert	11490.000	AV	38.9	40.5	-1.4	35.2	0.8	43.6	53.9	10.3	
Vert	17235.000	AV	37.5	42.9	0.1	35.0	0.8	46.3	53.9	7.6	
Vert	22980.000	AV	44.9	37.9	-0.6	34.7	0.8	48.3	53.9	5.6	

Result = Reading + Ant Factor + Loss (Cable+Attenuator+Filter+Distance factor(above 1 GHz)) - Gain(Amplifier)

Result(AV) = Reading + Ant Factor + Loss (Cable+Attenuator+Filter+Distance factor(above 1 GHz)) - Gain(Amplifier) + Duty Factor

*Other frequency noises omitted in this report were not seen or had enough margin (more than 20dB).

Distance factor: 1GHz-10GHz 20log(3.9m/3.0m)= 2.28dB
 10GHz-26.5GHz 20log(1.0m/3.0m)= -9.5dB
 26.5GHz-40GHz 20log(0.5m/3.0m)= -15.6dB

Radiated Spurious Emission

Test place	Ise EMC Lab.
Report No.	11232955H
Semi Anechoic Chamber	No.1
Date	April 21, 2016
Temperature / Humidity	23deg. C / 45 % RH
Engineer	Tomohisa Nakagawa (1-26.5GHz)
Mode	Tx 11ac-20 5745 MHz

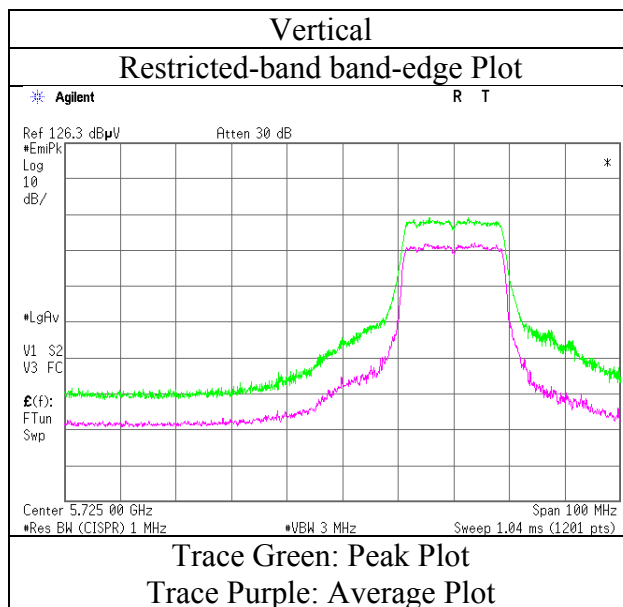
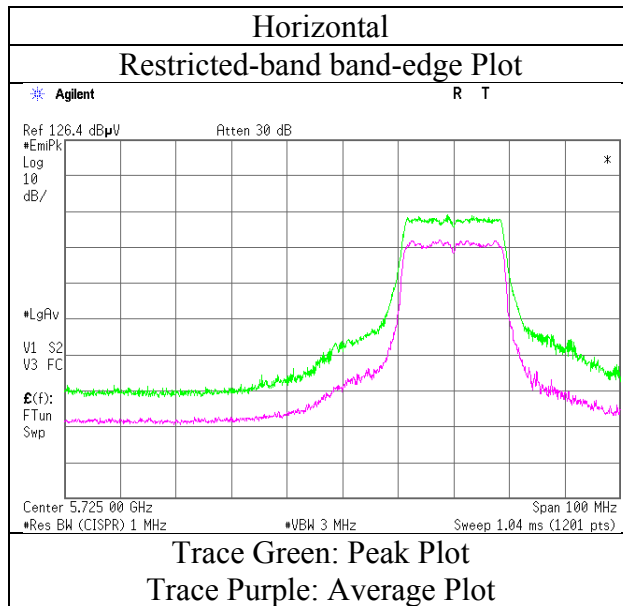

* Final result of restricted band edge was shown in tabular data.

Radiated Spurious Emission

Test place	Ise EMC Lab.	
Report No.	11232955H	
Semi Anechoic Chamber	No.1	No.1
Date	April 21, 2016	April 20, 2016
Temperature / Humidity	23deg. C / 45 % RH	23deg. C / 45 % RH
Engineer	Tomohisa Nakagawa (1-26.5GHz)	Tomohisa Nakagawa (Above 26.5GHz)
Mode	Tx 11ac-20 5785 MHz	

Polarity	Frequency [MHz]	Detector	Reading [dBuV]	Ant.Fac. [dB/m]	Loss [dB]	Gain [dB]	Duty Factor [dB]	Result [dBuV/m]	Limit [dBuV/m]	Margin [dB]	Remark
Hori	11570.000	PK	44.8	40.5	-1.4	35.2		48.7	73.9	25.2	
Hori	17355.000	PK	43.9	43.5	0.3	35.0		52.7	73.9	21.2	
Hori	23140.000	PK	49.9	37.9	-0.6	34.6		52.6	73.9	21.3	
Hori	11570.000	AV	37.4	40.5	-1.4	35.2	0.8	42.1	53.9	11.8	
Hori	17355.000	AV	38.2	43.5	0.3	35.0	0.8	47.8	53.9	6.1	
Hori	23140.000	AV	43.3	37.9	-0.6	34.6	0.8	46.8	53.9	7.1	
Vert	11570.000	PK	48.5	40.5	-1.4	35.2		52.4	73.9	21.5	
Vert	17355.000	PK	45.3	43.5	0.3	35.0		54.1	73.9	19.8	
Vert	23140.000	PK	50.0	37.9	-0.6	34.6		52.7	73.9	21.2	
Vert	11570.000	AV	41.8	40.5	-1.4	35.2	0.8	46.5	53.9	7.4	
Vert	17355.000	AV	36.8	43.5	0.3	35.0	0.8	46.4	53.9	7.5	
Vert	23140.000	AV	45.5	37.9	-0.6	34.6	0.8	49.0	53.9	4.9	

Result = Reading + Ant Factor + Loss (Cable+Attenuator+Filter+Distance factor(above 1 GHz)) - Gain(Amplifier)

Result(AV) = Reading + Ant Factor + Loss (Cable+Attenuator+Filter+Distance factor(above 1 GHz)) - Gain(Amplifier) + Duty Factor

*Other frequency noises omitted in this report were not seen or had enough margin (more than 20dB).

Distance factor: 1GHz-10GHz 20log(3.9m/3.0m)= 2.28dB
 10GHz-26.5GHz 20log(1.0m/3.0m)= -9.5dB
 26.5GHz-40GHz 20log(0.5m/3.0m)= -15.6dB

Radiated Spurious Emission

Test place	Ise EMC Lab.	
Report No.	11232955H	
Semi Anechoic Chamber	No.1	No.1
Date	April 21, 2016	April 20, 2016
Temperature / Humidity	23deg. C / 45 % RH	23deg. C / 45 % RH
Engineer	Tomohisa Nakagawa (1-26.5GHz)	Tomohisa Nakagawa (Above 26.5GHz)
Mode	Tx 11ac-20 5825 MHz	

Polarity	Frequency [MHz]	Detector	Reading [dBuV]	Ant.Fac. [dB/m]	Loss [dB]	Gain [dB]	Duty Factor [dB]	Result [dBuV/m]	Limit [dBuV/m]	Margin [dB]	Remark
Hori	5850.000	PK	61.5	33.0	6.6	35.5		65.6	122.2	56.6	
Hori	5855.000	PK	57.8	33.0	6.6	35.5		61.9	110.8	48.9	
Hori	5875.000	PK	48.4	33.0	6.6	35.5		52.5	105.2	52.7	
Hori	5925.000	PK	45.3	33.0	6.6	35.5		49.4	68.2	18.8	
Hori	11650.000	PK	46.1	40.5	-1.3	35.2		50.1	73.9	23.8	
Hori	17475.000	PK	44.3	44.0	0.4	35.0		53.7	73.9	20.2	
Hori	23300.000	PK	48.3	37.8	-0.5	34.5		51.1	73.9	22.8	
Hori	11650.000	AV	38.6	40.5	-1.3	35.2	0.8	43.4	53.9	10.5	
Hori	17475.000	AV	38.0	44.0	0.4	35.0	0.8	48.2	53.9	5.7	
Hori	23300.000	AV	42.9	37.8	-0.5	34.5	0.8	46.5	53.9	7.4	
Vert	5850.000	PK	61.9	33.0	6.6	35.5		66.0	122.2	56.2	
Vert	5855.000	PK	59.1	33.0	6.6	35.5		63.2	110.8	47.6	
Vert	5875.000	PK	49.6	33.0	6.6	35.5		53.7	105.2	51.5	
Vert	5925.000	PK	45.3	33.0	6.6	35.5		49.4	68.2	18.8	
Vert	11650.000	PK	47.4	40.5	-1.3	35.2		51.4	73.9	22.5	
Vert	17475.000	PK	44.1	44.0	0.4	35.0		53.5	73.9	20.4	
Vert	23300.000	PK	50.0	37.8	-0.5	34.5		52.8	73.9	21.1	
Vert	11650.000	AV	42.2	40.5	-1.3	35.2	0.8	47.0	53.9	6.9	
Vert	17475.000	AV	37.8	44.0	0.4	35.0	0.8	48.0	53.9	5.9	
Vert	23300.000	AV	46.2	37.8	-0.5	34.5	0.8	49.8	53.9	4.1	

Result = Reading + Ant Factor + Loss (Cable+Attenuator+Filter+Distance factor(above 1 GHz)) - Gain(Amplifier)

Result(AV) = Reading + Ant Factor + Loss (Cable+Attenuator+Filter+Distance factor(above 1 GHz)) - Gain(Amplifier) + Duty Factor

*Other frequency noises omitted in this report were not seen or had enough margin (more than 20dB).

Distance factor: 1GHz-10GHz 20log(3.9m/3.0m)= 2.28dB
 10GHz-26.5GHz 20log(1.0m/3.0m)= -9.5dB
 26.5GHz-40GHz 20log(0.5m/3.0m)= -15.6dB

Radiated Spurious Emission

Test place	Ise EMC Lab.
Report No.	11232955H
Semi Anechoic Chamber	No.1
Date	April 21, 2016
Temperature / Humidity	23deg. C / 45 % RH
Engineer	Tomohisa Nakagawa (1-26.5GHz)
Mode	Tx 11ac-20 5825 MHz

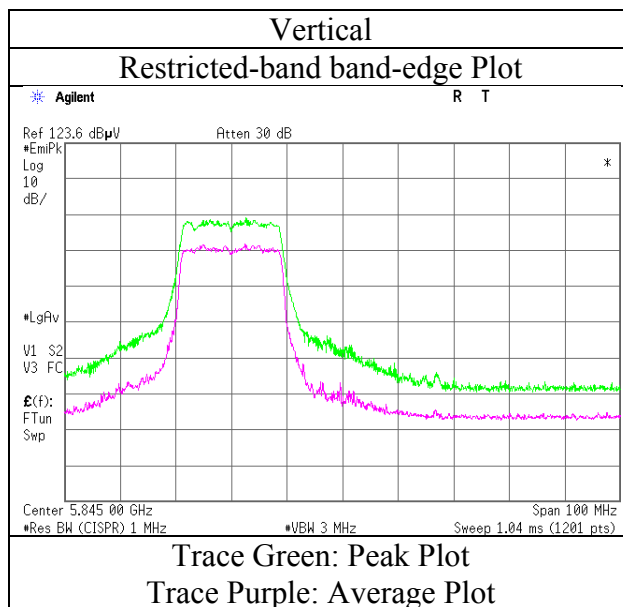
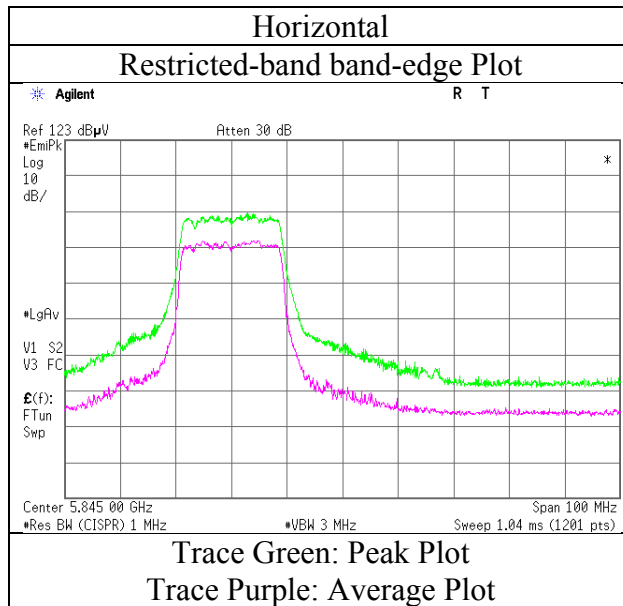

* Final result of restricted band edge was shown in tabular data.

Radiated Spurious Emission

Test place	Ise EMC Lab.	
Report No.	11232955H	
Semi Anechoic Chamber	No.1	No.1
Date	April 21, 2016	April 20, 2016
Temperature / Humidity	23deg. C / 45 % RH	23deg. C / 45 % RH
Engineer	Tomohisa Nakagawa	Tomohisa Nakagawa
	(1-26.5GHz)	(Above 26.5GHz)
Mode	Tx 11ac-40 5755 MHz	

Polarity	Frequency [MHz]	Detector	Reading [dBuV]	Ant.Fac. [dB/m]	Loss [dB]	Gain [dB]	Duty Factor [dB]	Result [dBuV/m]	Limit [dBuV/m]	Margin [dB]	Remark
Hori	5650.000	PK	44.8	32.8	6.5	35.4		48.7	68.2	19.5	
Hori	5700.000	PK	53.1	32.8	6.5	35.5		56.9	105.2	48.3	
Hori	5720.000	PK	61.4	32.9	6.5	35.5		65.3	110.8	45.5	
Hori	5725.000	PK	65.8	32.9	6.5	35.5		69.7	122.2	52.5	
Hori	11510.000	PK	44.4	40.5	-1.4	35.2		48.3	73.9	25.6	
Hori	17265.000	PK	44.2	43.1	0.2	35.0		52.5	73.9	21.4	
Hori	23020.000	PK	49.1	37.9	-0.6	34.7		51.7	73.9	22.2	
Hori	11510.000	AV	37.7	40.5	-3.2	35.2	1.2	41.0	53.9	12.9	
Hori	17265.000	AV	38.1	43.1	-1.9	35.0	1.2	45.5	53.9	8.4	
Hori	23020.000	AV	42.8	37.9	-0.6	34.7	1.2	46.6	53.9	7.3	
Vert	5650.000	PK	45.5	32.8	6.5	35.4		49.4	68.2	18.8	
Vert	5700.000	PK	52.9	32.8	6.5	35.5		56.7	105.2	48.5	
Vert	5720.000	PK	61.3	32.9	6.5	35.5		65.2	110.8	45.6	
Vert	5725.000	PK	64.5	32.9	6.5	35.5		68.4	122.2	53.8	
Vert	11510.000	PK	47.4	40.5	-1.4	35.2		51.3	73.9	22.6	
Vert	17265.000	PK	44.6	43.1	0.2	35.0		52.9	73.9	21.0	
Vert	23020.000	PK	48.7	37.9	-0.6	34.7		51.3	73.9	22.6	
Vert	11510.000	AV	41.6	40.5	-1.4	35.2	1.2	46.7	53.9	7.2	
Vert	17265.000	AV	37.5	43.1	0.2	35.0	1.2	47.0	53.9	6.9	
Vert	23020.000	AV	44.1	37.9	-0.6	34.7	1.2	47.9	53.9	6.0	

Result = Reading + Ant Factor + Loss (Cable+Attenuator+Filter+Distance factor(above 1 GHz)) - Gain(Amplifier)

Result(AV) = Reading + Ant Factor + Loss (Cable+Attenuator+Filter+Distance factor(above 1 GHz)) - Gain(Amplifier) + Duty Factor

*Other frequency noises omitted in this report were not seen or had enough margin (more than 20dB).

Distance factor: 1GHz-10GHz 20log(3.9m/3.0m)= 2.28dB
 10GHz-26.5GHz 20log(1.0m/3.0m)= -9.5dB
 26.5GHz-40GHz 20log(0.5m/3.0m)= -15.6dB

Radiated Spurious Emission

Test place	Ise EMC Lab.
Report No.	11232955H
Semi Anechoic Chamber	No.1
Date	April 21, 2016
Temperature / Humidity	23deg. C / 45 % RH
Engineer	Tomohisa Nakagawa (1-26.5GHz)
Mode	Tx 11ac-40 5755 MHz

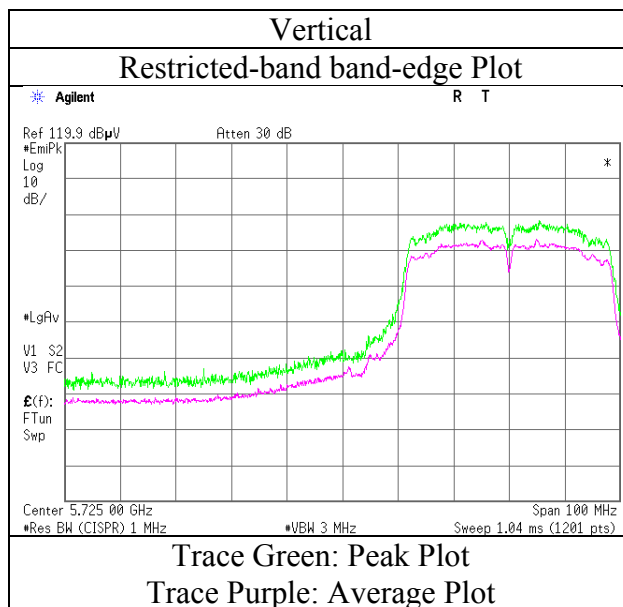
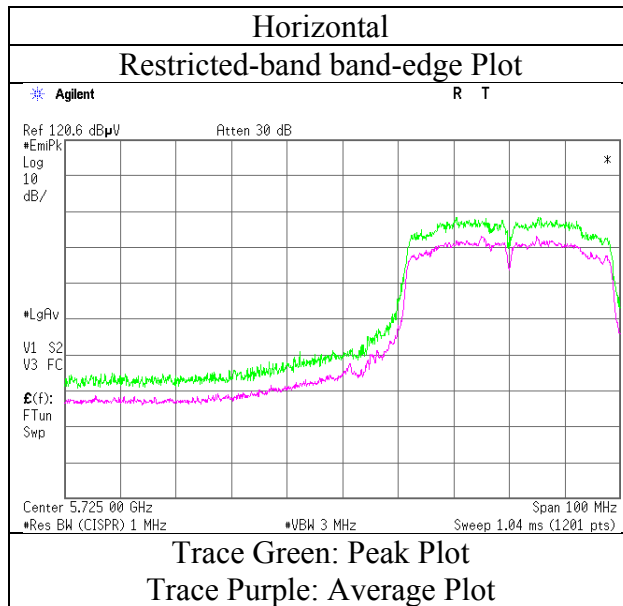

* Final result of restricted band edge was shown in tabular data.

UL Japan, Inc.

Ise EMC Lab.

4383-326 Asama-cho, Ise-shi, Mie-ken 516-0021 JAPAN

Telephone : +81 596 24 8999

Facsimile : +81 596 24 8124

Radiated Spurious Emission

Test place : Ise EMC Lab.
Report No. : 11232955H
Semi Anechoic Chamber : No.1
Date : April 21, 2016
Temperature / Humidity : 23deg. C / 45 % RH
Engineer : Tomohisa Nakagawa
Mode : Tx 11ac-40 5795 MHz

Polarity	Frequency [MHz]	Detector	Reading [dBuV]	Ant.Fac. [dB/m]	Loss [dB]	Gain [dB]	Duty Factor [dB]	Result [dBuV/m]	Limit [dBuV/m]	Margin [dB]	Remark
Hori	96.082	QP	43.4	9.3	8.4	39.2		21.9	43.5	21.6	
Hori	108.032	QP	43.3	11.1	8.6	39.2		23.8	43.5	19.7	
Hori	199.662	QP	43.0	16.3	9.6	39.2		29.7	43.5	13.8	
Hori	320.342	QP	45.8	13.9	10.7	38.7		31.7	46.0	14.3	
Hori	400.498	QP	46.3	15.6	11.3	38.5		34.7	46.0	11.3	
Hori	698.798	QP	45.0	19.8	13.2	38.4		39.6	46.0	6.4	
Vert	96.082	QP	38.8	9.3	8.4	39.2		17.3	43.5	26.2	
Vert	108.032	QP	39.3	11.1	8.6	39.2		19.8	43.5	23.7	
Vert	200.000	QP	33.2	16.3	9.7	39.2		20.0	43.5	23.5	
Vert	320.342	QP	46.3	13.9	10.7	38.7		32.2	46.0	13.8	
Vert	400.498	QP	38.0	15.6	11.3	38.5		26.4	46.0	19.6	
Vert	698.598	QP	47.8	19.8	13.2	38.4		42.4	46.0	3.6	
Hori	5850.000	PK	52.3	33.0	6.6	35.5		56.4	122.2	65.8	
Hori	5855.000	PK	50.3	33.0	6.6	35.5		54.4	110.8	56.4	
Hori	5875.000	PK	47.6	33.0	6.6	35.5		51.7	105.2	53.5	
Hori	5925.000	PK	43.5	33.0	6.6	35.5		47.6	68.2	20.6	
Hori	11590.000	PK	44.5	40.5	-1.4	35.2		48.4	73.9	25.5	
Hori	17385.000	PK	43.8	43.6	0.3	35.0		52.7	73.9	21.2	
Hori	23180.000	PK	48.0	37.9	-0.6	34.6		50.7	73.9	23.2	
Hori	11590.000	AV	38.4	40.5	-1.4	35.2	1.2	43.5	53.9	10.4	
Hori	17385.000	AV	37.2	43.6	0.3	35.0	1.2	47.3	53.9	6.6	
Hori	23180.000	AV	42.6	37.9	-0.6	34.6	1.2	46.5	53.9	7.4	
Vert	5850.000	PK	51.8	33.0	6.6	35.5		55.9	122.2	66.3	
Vert	5855.000	PK	49.8	33.0	6.6	35.5		53.9	110.8	56.9	
Vert	5875.000	PK	48.1	33.0	6.6	35.5		52.2	105.2	53.0	
Vert	5925.000	PK	44.4	33.0	6.6	35.5		48.5	68.2	19.7	
Vert	11590.000	PK	47.8	40.5	-1.4	35.2		51.7	73.9	22.2	
Vert	17385.000	PK	44.8	43.6	0.3	35.0		53.7	73.9	20.2	
Vert	23180.000	PK	51.3	37.9	-0.6	34.6		54.0	73.9	19.9	
Vert	11590.000	AV	41.1	40.5	-1.4	35.2	1.2	46.2	53.9	7.7	
Vert	17385.000	AV	36.8	43.6	0.3	35.0	1.2	46.9	53.9	7.0	
Vert	23180.000	AV	45.7	37.9	-0.6	34.6	1.2	49.6	53.9	4.3	

Result = Reading + Ant Factor + Loss (Cable+Attenuator+Filter+Distance factor(above 1 GHz)) - Gain(Amplifier)

Result(AV) = Reading + Ant Factor + Loss (Cable+Attenuator+Filter+Distance factor(above 1 GHz)) - Gain(Amplifier) + Duty Factor

*Other frequency noises omitted in this report were not seen or had enough margin (more than 20dB).

Distance factor: 1GHz-10GHz 20log(3.9m/3.0m)= 2.28dB
10GHz-26.5GHz 20log(1.0m/3.0m)= -9.5dB
26.5GHz-40GHz 20log(0.5m/3.0m)= -15.6dB

Radiated Spurious Emission
(Plot data, Worst case)

Test place	Ise EMC Lab.	
Report No.	11232955H	
Semi Anechoic Chamber	No.1	No.1
Date	April 21, 2016	April 20, 2016
Temperature / Humidity	23deg. C / 45 % RH	23deg. C / 45 % RH
Engineer	Tomohisa Nakagawa (1-26.5GHz)	Tomohisa Nakagawa (Above 26.5GHz and Below 1GHz)
Mode	Tx 11ac-40 5795 MHz	

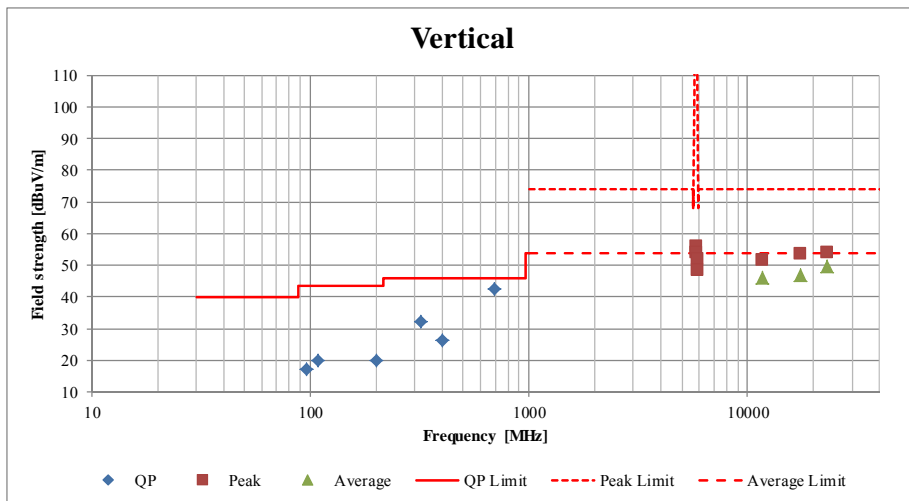
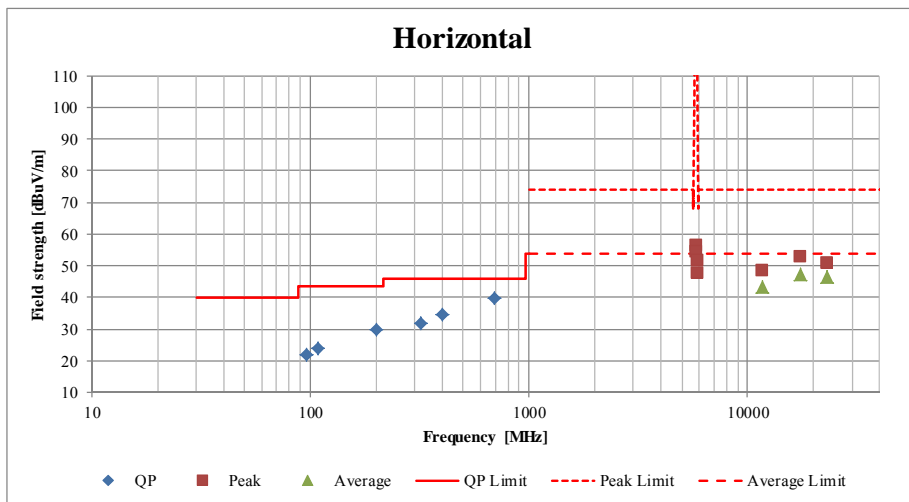

*These plots data contains sufficient number to show the trend of characteristic features for EUT.

Radiated Spurious Emission

Test place	Ise EMC Lab.
Report No.	11232955H
Semi Anechoic Chamber	No.1
Date	April 21, 2016
Temperature / Humidity	23deg. C / 45 % RH
Engineer	Tomohisa Nakagawa (1-26.5GHz)
Mode	Tx 11ac-40 5795 MHz

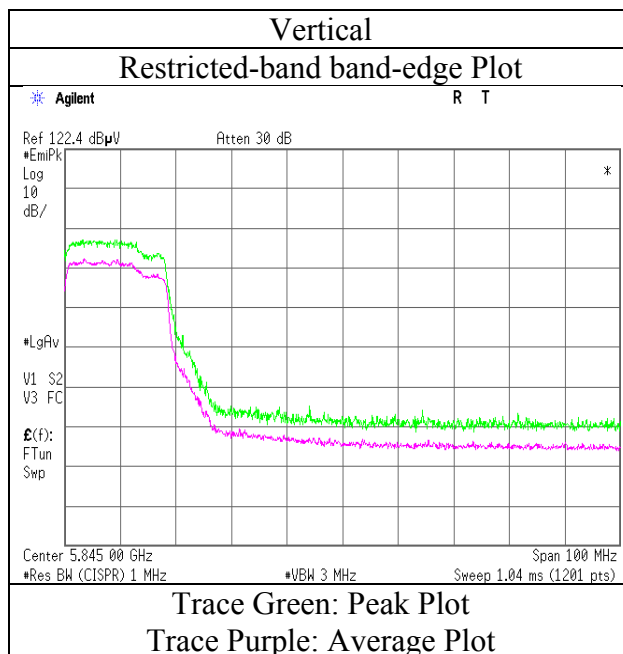
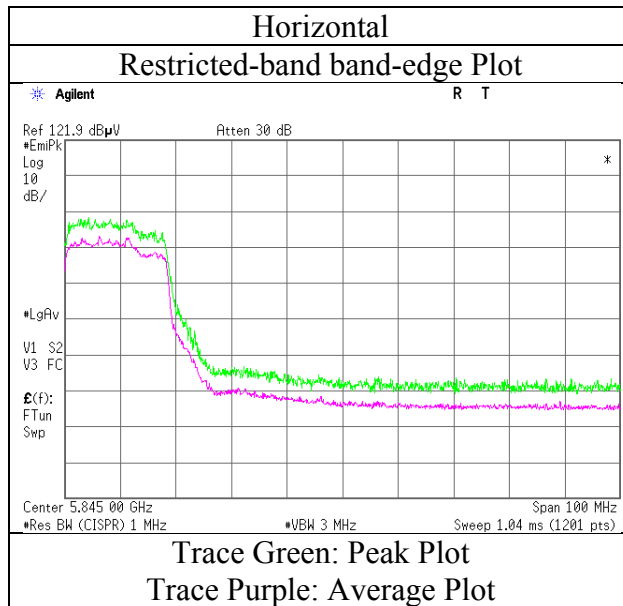

* Final result of restricted band edge was shown in tabular data.

Radiated Spurious Emission

Test place	Ise EMC Lab.	
Report No.	11232955H	
Semi Anechoic Chamber	No.1	No.1
Date	April 21, 2016	April 20, 2016
Temperature / Humidity	23deg. C / 45 % RH	23deg. C / 45 % RH
Engineer	Tomohisa Nakagawa	Tomohisa Nakagawa
	(1-26.5GHz)	(Above 26.5GHz)
Mode	Tx 11ac-80 5775 MHz	

Polarity	Frequency [MHz]	Detector	Reading [dBuV]	Ant.Fac. [dB/m]	Loss [dB]	Gain [dB]	Duty Factor [dB]	Result [dBuV/m]	Limit [dBuV/m]	Margin [dB]	Remark
Hori	5650.000	PK	50.4	32.8	6.5	35.4		54.3	68.2	13.9	
Hori	5677.303	PK	58.1	32.8	6.5	35.4		62.0	88.4	26.4	
Hori	5680.815	PK	59.2	32.8	6.5	35.4		63.1	91.0	27.9	
Hori	5691.710	PK	59.7	32.8	6.5	35.4		63.6	99.1	35.5	
Hori	5700.000	PK	57.0	32.8	6.5	35.5		60.8	105.2	44.4	
Hori	5720.000	PK	61.2	32.9	6.5	35.5		65.1	110.8	45.7	
Hori	5725.000	PK	59.8	32.9	6.5	35.5		63.7	122.2	58.5	
Hori	5850.000	PK	54.7	33.0	6.6	35.5		58.8	122.2	63.4	
Hori	5855.000	PK	53.5	33.0	6.6	35.5		57.6	110.8	53.2	
Hori	5875.000	PK	49.4	33.0	6.6	35.5		53.5	105.2	51.7	
Hori	5925.000	PK	44.6	33.0	6.6	35.5		48.7	68.2	19.5	
Hori	11550.000	PK	43.2	40.5	-1.4	35.2		47.1	73.9	26.8	
Hori	17325.000	PK	44.1	43.3	0.3	35.0		52.7	73.9	21.2	
Hori	23100.000	PK	47.6	37.9	-0.6	34.6		50.3	73.9	23.6	
Hori	11550.000	AV	36.7	40.5	-1.4	35.2	1.5	42.1	53.9	11.9	
Hori	17325.000	AV	36.5	43.3	0.3	35.0	1.5	46.6	53.9	7.4	
Hori	23100.000	AV	42.4	37.9	-0.6	34.6	1.5	46.6	53.9	7.3	
Vert	5650.000	PK	50.4	32.8	6.5	35.4		54.3	68.2	13.9	
Vert	5677.290	PK	57.0	32.8	6.5	35.4		60.9	88.4	27.5	
Vert	5680.815	PK	58.6	32.8	6.5	35.4		62.5	91.0	28.5	
Vert	5691.710	PK	59.0	32.8	6.5	35.4		62.9	99.1	36.2	
Vert	5700.000	PK	59.0	32.8	6.5	35.5		62.8	105.2	42.4	
Vert	5720.000	PK	62.1	32.9	6.5	35.5		66.0	110.8	44.8	
Vert	5725.000	PK	61.7	32.9	6.5	35.5		65.6	122.2	56.6	
Vert	5850.000	PK	54.0	33.0	6.6	35.5		58.1	122.2	64.1	
Vert	5855.000	PK	52.0	33.0	6.6	35.5		56.1	110.8	54.7	
Vert	5875.000	PK	49.8	33.0	6.6	35.5		53.9	105.2	51.3	
Vert	5925.000	PK	44.5	33.0	6.6	35.5		48.6	68.2	19.6	
Vert	11550.000	PK	45.8	40.5	-1.4	35.2		49.7	73.9	24.2	
Vert	17325.000	PK	44.9	43.3	0.3	35.0		53.5	73.9	20.4	
Vert	23100.000	PK	51.0	37.9	-0.6	34.6		53.7	73.9	20.2	
Vert	11550.000	AV	40.2	40.5	-1.4	35.2	1.5	45.6	53.9	8.4	
Vert	17325.000	AV	37.0	43.3	0.3	35.0	1.5	47.1	53.9	6.9	
Vert	23100.000	AV	45.5	37.9	-0.6	34.6	1.5	49.7	53.9	4.2	

Result = Reading + Ant Factor + Loss (Cable+Attenuator+Filter+Distance factor(above 1 GHz)) - Gain(Amplifier)

Result(AV) = Reading + Ant Factor + Loss (Cable+Attenuator+Filter+Distance factor(above 1 GHz)) - Gain(Amplifier) + Duty Factor

*Other frequency noises omitted in this report were not seen or had enough margin (more than 20dB).

Distance factor: 1GHz-10GHz 20log(3.9m/3.0m)= 2.28dB
 10GHz-26.5GHz 20log(1.0m/3.0m)= -9.5dB
 26.5GHz-40GHz 20log(0.5m/3.0m)= -15.6dB

Radiated Spurious Emission

Test place	Ise EMC Lab.
Report No.	11232955H
Semi Anechoic Chamber	No.1
Date	April 21, 2016
Temperature / Humidity	23deg. C / 45 % RH
Engineer	Tomohisa Nakagawa (1-26.5GHz)
Mode	Tx 11ac-80 5775 MHz

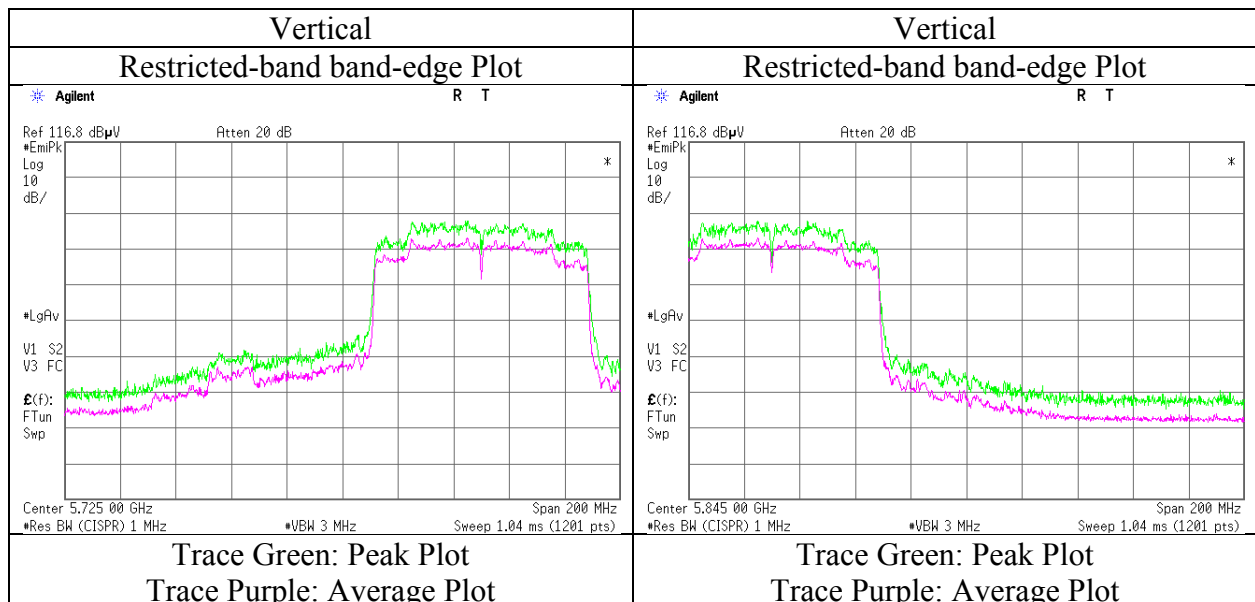
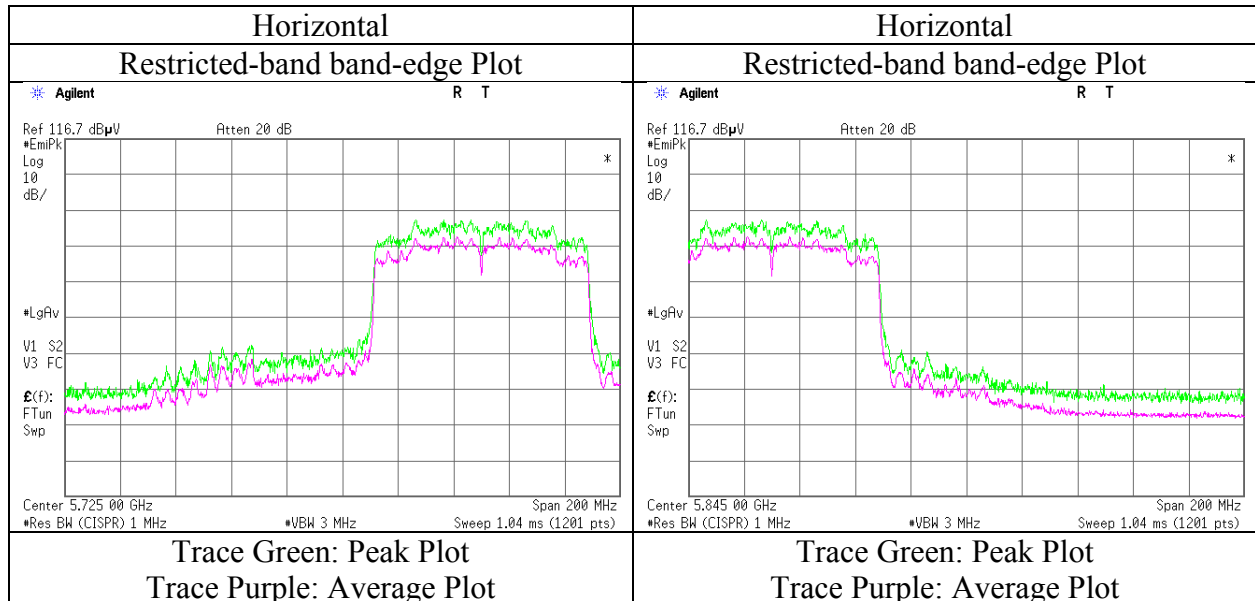

* Final result of restricted band edge was shown in tabular data.

UL Japan, Inc.

Ise EMC Lab.

4383-326 Asama-cho, Ise-shi, Mie-ken 516-0021 JAPAN

Telephone : +81 596 24 8999

Facsimile : +81 596 24 8124

Conducted Spurious Emission

Test place	Ise EMC Lab. No.3 Measurement Room
Report No.	11232955H
Date	April 20, 2016
Temperature / Humidity	23deg. C / 35 % RH
Engineer	Yutaka Yoshida
Mode	Tx 11ac-40 5795MHz

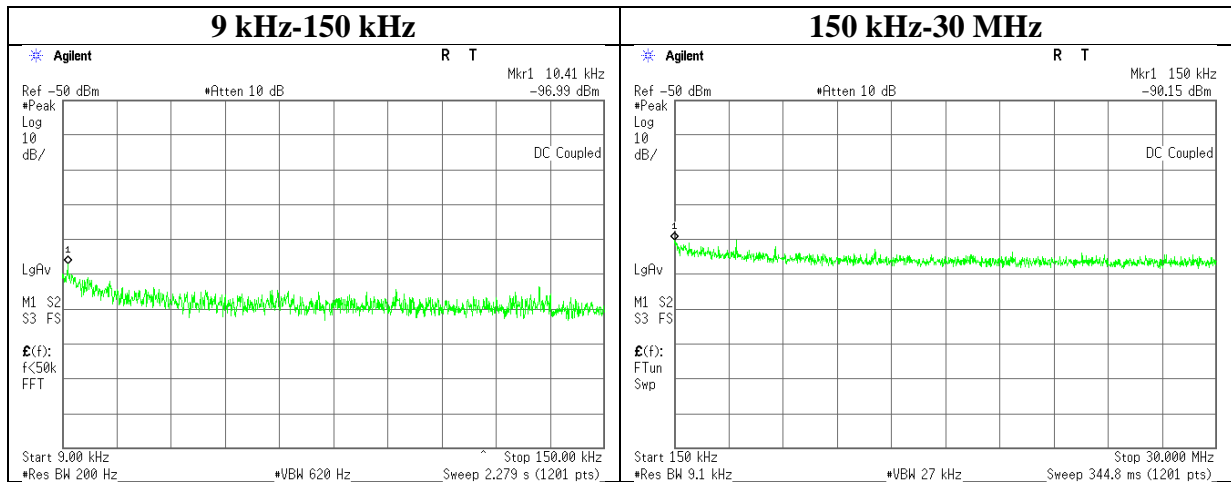

Frequency [kHz]	Reading [dBm]	Cable Loss [dB]	Attenuator [dB]	Antenna Gain [dBi]	N (Number of Output)	EIRP [dBm]	Distance [m]	Ground bounce [dB]	E (field strength) [dBuV/m]	Limit [dBuV/m]	Margin [dB]	Remark
10.41	-97.0	0.44	9.7	2.3	2	-81.5	300	6.0	-20.3	47.2	67.5	
150.00	-90.2	0.44	9.7	2.3	2	-74.7	300	6.0	-13.4	24.0	37.4	

$E = \text{EIRP} - 20 \cdot \log(D) + \text{Ground bounce} + 104.8 \text{ [dBuV/m]}$

$\text{EIRP} = \text{Reading} + \text{Cable Loss} + \text{Attenuator} + \text{Antenna Gain} + 10 \cdot \log(N)$

APPENDIX 2: Test instruments

Test equipment

Control No.	Instrument	Manufacturer	Model No	Serial No	Test Item	Calibration Date * Interval(month)
MAT-89	Attenuator	Weinschel Associates	WA56-10	56100305	AT	2015/06/01 * 12
MAT-90	Attenuator	Weinschel Associates	WA56-10	56100306	AT	2015/06/01 * 12
MPM-16	Power Meter	Agilent	8990B	MY51000271	AT	2016/04/07 * 12
MPSE-22	Power sensor	Agilent	N1923A	MY54070003	AT	2016/04/07 * 12
MPSE-23	Power sensor	Agilent	N1923A	MY54070004	AT	2016/04/07 * 12
MOS-30	Thermo-Hygrometer	Custom	CTH-201	3001	AT	2015/07/07 * 12
MRENT-126	Spectrum Analyzer	KEYSIGHT	E4440A	MY46185516	AT	2015/07/31 * 12
MOS-29	Thermo-Hygrometer	Custom	CTH-201	2901	AT	2016/01/21 * 12
MAEC-01	Semi Anechoic Chamber(NSA)	TDK	Semi Anechoic Chamber 10m	DA-06881	RE/CE	2015/09/19 * 12
MOS-27	Thermo-Hygrometer	CUSTOM	CTH-201	A08Q26	RE/CE	2016/01/21 * 12
MJM-25	Measure	KOMELON	KMC-36	-	RE/CE	-
COTS-MEMI	EMI measurement program	TSJ	TEPTO-DV	-	RE/CE	-
MTR-09	EMI Test Receiver	Rohde & Schwarz	ESU26	100412	RE	2015/06/08 * 12
KBA-05	Biconical Antenna	Schwarzbeck	BBA9106	2513	RE	2015/11/02 * 12
MLA-20	Logperiodic Antenna(200-1000MHz)	Schwarzbeck	VUSLP9111B	911B-189	RE	2016/01/30 * 12
MAT-08	Attenuator(6dB)	Weinschel Corp	2	BK7971	RE	2015/11/10 * 12
MCC-02	Coaxial Cable	Suhner/storm/Agilent/T SJ	-	-	RE	2015/09/29 * 12
MPA-19	Pre Amplifier	MITEQ	MLA-10K01-B01-35	1237616	RE	2016/02/25 * 12
MMM-03	Digital Tester	Fluke	FLUKE 26-3	78030621	RE	2015/08/19 * 12
MHA-05	Horn Antenna 1-18GHz	Schwarzbeck	BBHA9120D	253	RE	2015/05/18 * 12
MPA-01	Pre Amplifier	Agilent	8449B	3008A01671	RE	2016/02/26 * 12
MCC-165	Microwave Cable	Junkosha	MWX221	1203S213(1m) / 1311S166(5m)	RE	2015/11/10 * 12
MCC-54	Microwave Cable	Suhner	SUCOFLEX101	2873(1m) / 2876(5m)	RE	2016/03/18 * 12
MPA-03	Microwave System Power Amplifier	Agilent	83050A	3950M00205	RE	2015/06/02 * 12
MLS-23	LISN(AMN)	Schwarzbeck	NSLK8127	8127-729	CE	2015/07/10 * 12
MCC-03	Coaxial Cable	Fujikura/Suhner/TSJ	5D-2W(20m)/3D-2W(7.5m)/RG400u(1.5m)/RFM-E421(Switcher)	-/01068(Switcher)	CE	2015/09/29 * 12
MAT-64	Attenuator(13dB)	JFW Industries, Inc.	50FP-013H2 N	-	CE	2016/01/14 * 12
MHA-29	Horn Antenna 26.5-40GHz	ETS LINDGREN	3160-10	00152399	RE	2015/09/04 * 12
MPA-22	Pre Amplifier	MITEQ, Inc	AMF-6F-2600400-33-8P / AMF-4F-2600400-33-8P	1871355 / 1871328	RE	2015/09/03 * 12

The expiration date of the calibration is the end of the expired month.

All equipment is calibrated with valid calibrations. Each measurement data is traceable to the national or international standards.

As for some calibrations performed after the tested dates, those test equipment have been controlled by means of an unbroken chains of calibrations.

Test Item: **CE: Conducted Emission**
 RE: Radiated Emission
 AT: Antenna Terminal Conducted test

UL Japan, Inc.

Ise EMC Lab.

4383-326 Asama-cho, Ise-shi, Mie-ken 516-0021 JAPAN

Telephone : +81 596 24 8999

Facsimile : +81 596 24 8124