



RADIO TEST REPORT

Test Report No. : 11220705H-R1

Applicant : PANASONIC CORPORATION OF NORTH AMERICA

Type of Equipment : Wireless Module
(Tested inside of Panasonic Tablet PC FZ-Q1)

Model No. : WL13A

FCC ID : ACJ9TGWL13A

Test regulation : FCC Part 15 Subpart E: 2015

Test Result : Complied

1. This test report shall not be reproduced in full or partial, without the written approval of UL Japan, Inc.
2. The results in this report apply only to the sample tested.
3. This sample tested is in compliance with the above regulation.
4. The test results in this report are traceable to the national or international standards.
5. This test report must not be used by the customer to claim product certification, approval, or endorsement by NVLAP, NIST, or any agency of the Federal Government.
6. This test report covers Radio technical requirements. It does not cover administrative issues such as Manual or non-Radio test related Requirements. (if applicable)
7. This report is a revised version of 11220705H. 11220705H is replaced with this report.

Date of test: November 24 to December 20, 2015
January 17 and 26, 2016

Representative test engineer:

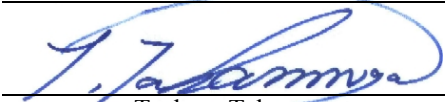
Tsubasa Takayama

Engineer
Consumer Technology Division

Approved by:

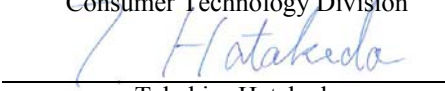
Takahiro Hatakeda

Leader
Consumer Technology Division



NVLAP LAB CODE: 200572-0

This laboratory is accredited by the NVLAP LAB CODE 200572-0, U.S.A. The tests reported herein have been performed in accordance with its terms of accreditation.
*As for the range of Accreditation in NVLAP, you may refer to the WEB address,
http://japan.ul.com/resources/emc_accredited/

UL Japan, Inc.

Ise EMC Lab.

4383-326 Asama-cho, Ise-shi, Mie-ken 516-0021 JAPAN

Telephone : +81 596 24 8999

Facsimile : +81 596 24 8124

13-EM-F0429

CONTENTS	PAGE
SECTION 1: Customer information.....	4
SECTION 2: Equipment under test (E.U.T.).....	4
SECTION 3: Test specification, procedures & results.....	5
SECTION 4: Operation of E.U.T. during testing.....	8
SECTION 5: Conducted Emission.....	11
SECTION 6: Radiated Spurious Emission and Band Edge Compliance.....	12
SECTION 7: Antenna Terminal Conducted Tests.....	14
APPENDIX 1: Test data	15
Conducted Emission	15
99 % Occupied Bandwidth.....	16
6 dB Bandwidth	24
Maximum Conducted Output Power	30
Maximum Power Spectral Density	42
Radiated Spurious Emission	55
Conducted Spurious Emission	67
APPENDIX 2: Test instruments	71
APPENDIX 3: Photographs of test setup	73
Conducted Emission	73
Radiated Spurious Emission	74
Worst Case Position.....	75

SECTION 1: Customer information

Company Name : PANASONIC CORPORATION OF NORTH AMERICA
Address : Two Riverfront Plaza, 9th Floor, Newark, NJ 07102-5490

SECTION 2: Equipment under test (E.U.T.)

2.1 Identification of E.U.T.

Type of Equipment : Wireless Module
(Tested inside of Panasonic Detachable PC FZ-Q1)
Model No. : WL13A
Serial No. : Refer to Section 4, Clause 4.2
Receipt Date of Sample : November 19, 2015
Modification of EUT : No Modification by the test lab

2.2 Product Description

Model: WL13A (referred to as the EUT in this report) is a Wireless Module.

Radio Specification

Tx Frequency Bands	802.11a/b/g/n/ac: 2412 - 2462 MHz, b / g / HT20 / HT40 5180 - 5240 MHz, a / HT20 / HT40 / HT80 5260 - 5320 MHz, a / HT20 / HT40 / HT80 5500 - 5720 MHz, a / HT20 / HT40 / HT80 5745 - 5825 MHz, a / HT20 / HT40 / HT80 Bluetooth: 2402 - 2480 MHz
Modulation	802.11a/b/g/n/ac : BPSK, QPSK, CCK, 16-QAM and 64-QAM and 256-QAM Bluetooth 4.0+LE: GFSK, DQPSK, 8-DPSK
Duty Cycle	WLAN: 100% Bluetooth 89%

SECTION 3: Test specification, procedures & results

3.1 Test Specification

Test Specification : FCC Part 15 Subpart E: 2015, final revised on November 23, 2015
*Some parts are effective on and after December 17, 2015 or December 23, 2015. The revision does not affect the test specification applied to the EUT.

Title : FCC 47CFR Part15 Radio Frequency Device Subpart E
Unlicensed National Information Infrastructure Devices
Section 15.407 General technical requirements

3.2 Procedures and results

Item	Test Procedure	Specification	Worst margin	Results	Remarks
Conducted Emission	FCC: ANSI C63.10-2013	FCC: 15.407 (b) (6) / 15.207	QP 17.3 dB, 0.51200 MHz, N AV 12.8 dB, 0.51200 MHz, N	Complied	-
	IC: RSS-Gen 8.8	IC: RSS-Gen 8.8			
26 dB Emission Bandwidth	FCC: KDB Publication Number 789033 D02, 662911 D01 and D02 IC: -	FCC: 15.407 (a) (1) (2) (3) IC: -	See data	N/A	Conducted
Maximum Conducted Output Power	FCC: KDB Publication Number 789033 D02, 662911 D01 and D02 IC: -	FCC: 15.407 (a) (1) (2) (3) IC: RSS-247 6.2.1 (1) 6.2.2 (1) 6.2.3 (1) 6.2.4 (1)		Complied	Conducted
Maximum Power Spectral Density	FCC: KDB Publication Number 789033 D02, 662911 D01 and D02 IC: -	FCC : 15.407 (a) (1) (2) (3) IC: RSS-247 6.2.1 (1) 6.2.2 (1) 6.2.3 (1) 6.2.4 (1)		Complied	Conducted
Spurious Emission Restricted Band Edge	FCC: KDB Publication Number 789033 D02, 662911 D01 and D02 IC: -	FCC: 15.407 (b), 15.205 and 15.209 IC: RSS-247 6.2.1 (2) 6.2.2 (2) 6.2.3 (2) 6.2.4 (2)		1.5 dB 5725.000 MHz, PK, Hori.	Complied
6 dB Emission Bandwidth	FCC: ANSI C63.10-2013	FCC: 15.407 (e)	See data	Complied	Conducted
	IC: -	IC: RSS-247 6.2.4 (1)			

Note: UL Japan, Inc.'s EMI Work Procedures No. 13-EM-W0420 and 13-EM-W0422.

*1) Radiated test was selected over 30 MHz based on section FCC 15.407 (b), KDB 789033 D02 G.3.b).

* In case any questions arise about test procedure, ANSI C63.10: 2013 is also referred.

3.3 Addition to standard

Item	Test Procedure	Specification	Worst margin	Results	Remarks
99 % Occupied Band Width	RSS-Gen 6.6	IC: -	N/A	N/A	Conducted

Other than above, no addition, exclusion nor deviation has been made from the standard.

UL Japan, Inc.

Ise EMC Lab.

4383-326 Asama-cho, Ise-shi, Mie-ken 516-0021 JAPAN

Telephone : +81 596 24 8999

Facsimile : +81 596 24 8124

3.4 Uncertainty

EMI

The following uncertainties have been calculated to provide a confidence level of 95 % using a coverage factor $k=2$.
Ise EMC Lab.

Antenna terminal test Uncertainty (+/-)							
Power meter		Conducted emission and Power density			Conducted emission		Channel power
Below 1 GHz	Above 1 GHz	Below 1 GHz	1 GHz -3 GHz	3 GHz -18 GHz	18 GHz -26.5 GHz	26.5 GHz -40 GHz	
0.9 dB	1.0 dB	1.4 dB	1.7 dB	2.8 dB	2.8 dB	2.9 dB	

Frequency range	Conducted emission using AMN(LISN) (+dB)
0.009 – 0.15MHz	3.5 dB
0.15 – 30MHz	2.9 dB

Test distance	Radiated emission (\pm dB) 9 kHz - 30 MHz
3m	3.8 dB
10m	3.7 dB

Polarity	Radiated emission (Below 1GHz)			
	(3 m*)(\pm dB)		(10 m*)(\pm dB)	
	30 – 300 MHz	300 – 1000MHz	30 – 300 MHz	300 – 1000MHz
Horizontal	4.8 dB	5.2 dB	4.8 dB	5.0 dB
Vertical	4.5 dB	5.9 dB	4.8 dB	5.1 dB

Radiated emission				
(3 m*)(\pm dB)		(1 m*)(\pm dB)	(0.5 m*)(\pm dB)	(10 m*)(\pm dB)
1 – 6GHz	6 – 18GHz	10 – 26.5 GHz	26.5 – 40GHz	1 -18 GHz
5.1 dB	5.3 dB	5.1 dB	5.1 dB	5.3 dB

*Measurement distance

Conducted Emission test

The data listed in this test report has enough margin, more than the site margin.

Radiated emission test

The data listed in this report meets the limits unless the uncertainty is taken into consideration.

3.5 Test Location

UL Japan, Inc. Ise EMC Lab. *NVLAP Lab. code: 200572-0
 4383-326 Asama-cho, Ise-shi, Mie-ken 516-0021 JAPAN
 Telephone: +81 596 24 8999, Facsimile: +81 596 24 8124

Test site	IC Registration Number	Width x Depth x Height (m)	Size of reference ground plane (m) / horizontal conducting plane	Other rooms	Maximum measurement distance
No.1 semi-anechoic chamber	2973C-1	19.2 x 11.2 x 7.7	7.0 x 6.0	No.1 Power source room	10 m
No.2 semi-anechoic chamber	2973C-2	7.5 x 5.8 x 5.2	4.0 x 4.0	-	3 m
No.3 semi-anechoic chamber	2973C-3	12.0 x 8.5 x 5.9	6.8 x 5.75	No.3 Preparation room	3 m
No.3 shielded room	-	4.0 x 6.0 x 2.7	N/A	-	-
No.4 semi-anechoic chamber	2973C-4	12.0 x 8.5 x 5.9	6.8 x 5.75	No.4 Preparation room	3 m
No.4 shielded room	-	4.0 x 6.0 x 2.7	N/A	-	-
No.5 semi-anechoic chamber	-	6.0 x 6.0 x 3.9	6.0 x 6.0	-	-
No.6 shielded room	-	4.0 x 4.5 x 2.7	4.0 x 4.5	-	-
No.6 measurement room	-	4.75 x 5.4 x 3.0	4.75 x 4.15	-	-
No.7 shielded room	-	4.7 x 7.5 x 2.7	4.7 x 7.5	-	-
No.8 measurement room	-	3.1 x 5.0 x 2.7	N/A	-	-
No.9 measurement room	-	8.8 x 4.6 x 2.8	2.4 x 2.4	-	-
No.11 measurement room	-	6.2 x 4.7 x 3.0	4.8 x 4.6	-	-

* Size of vertical conducting plane (for Conducted Emission test) : 2.0 x 2.0 m for No.1, No.2, No.3, and No.4 semi-anechoic chambers and No.3 and No.4 shielded rooms.

3.6 Test data, Test instruments, and Test set up

Refer to APPENDIX.

SECTION 4: Operation of E.U.T. during testing

4.1 Operating Mode(s)

Test operating mode was determined as follows according to “Section 1 of 6 802.11 a/b/g/n testing - Managing Complex Regulatory Approvals -” of TCB Council Workshop October 2009 and also was judged the necessity of 802.11ac mode by the pre-test.

Mode	Remarks*
IEEE 802.11a (11a)	6 Mbps, PN9
IEEE 802.11n SISO 20 MHz BW (11n-20)	MCS 0 (Long GI), PN9
IEEE 802.11ac SISO 20 MHz BW (11ac-20)	VHT0 (Long GI), PN9
IEEE 802.11n MIMO 20 MHz BW (11n-20)	MCS 8 (Long GI), PN9
IEEE 802.11ac MIMO 20 MHz BW (11ac-20)	VHT 8 (Long GI), PN9
IEEE 802.11n SISO 40 MHz BW (11n-40)	MCS 0 (Long GI), PN9
IEEE 802.11ac SISO 40 MHz BW (11ac-40)	VHT0 (Long GI), PN9
IEEE 802.11n MIMO 40 MHz BW (11n-40)	MCS 8 (Long GI), PN9
IEEE 802.11ac MIMO 40 MHz BW (11ac-40)	VHT 8 (Long GI), PN9
IEEE 802.11ac SISO 80 MHz BW (11ac-80)	VHT 0 (Long GI), PN9
IEEE 802.11ac MIMO 80 MHz BW (11ac-80)	VHT8 (Long GI), PN9

*The details of Operation mode(s)

Test Item	Operating Mode	Tested Antenna	Tested Frequency
			Upper Band
Conducted Emission *1)	11ac-80 Tx	A+B	5775 MHz
99 % Occupied Bandwidth, 6 dB Bandwidth *1)	11a Tx	A, B	5745 MHz
	11ac-20 Tx		5785 MHz
			5825 MHz
	11ac-40 Tx	A, B	5755 MHz
			5795 MHz
	11ac-80 Tx	A, B	5775 MHz
Conducted Spurious Emission *1)	11a Tx	B	5745 MHz
	11ac-20 Tx	A+B	
	11ac-40 Tx	A+B	5795 MHz
	11ac-80 Tx	A+B	5775 MHz
Maximum Power Spectral Density *1)	11a Tx	A, B	5745 MHz
			5785 MHz
			5825 MHz
	11ac-20 Tx	A+B	5745 MHz
			5785 MHz
		5825 MHz	
	11ac-40 Tx	A+B	5755 MHz
			5795 MHz
	11ac-80 Tx	A+B	5775 MHz
Maximum Conducted Output Power *1)	11a Tx	A, B	5745 MHz
			5785 MHz
			5825 MHz
	11n-20 Tx	A, B, A+B	5745 MHz
	11ac-20 Tx		5785 MHz
		5825 MHz	
	11n-40 Tx	A, B, A+B	5755 MHz
	11ac-40 Tx		5795 MHz
	11ac-80 Tx	A, B, A+B	5775 MHz
Radiated Spurious Emission (Below 1 GHz) *1)	11ac-80 Tx *2)	A+B *3)	5775 MHz
Radiated Spurious Emission (Above 1 GHz) *1)	11ac-20 Tx	A+B *3)	5745 MHz
			5785 MHz
			5825 MHz
	11ac-40 Tx	A+B *3)	5710 MHz
		5755 MHz	
		5795 MHz	
	11ac-80 Tx	A+B *3)	5775 MHz

*1) The test was only performed with UNII-3 band.
*2) The mode was tested as a representative, because it had the highest power at antenna terminal test.
*3) After the comparison MIMO and SISO in pre-check, test was performed with MIMO as a representative as it had worst data.

4.2 Configuration and peripherals

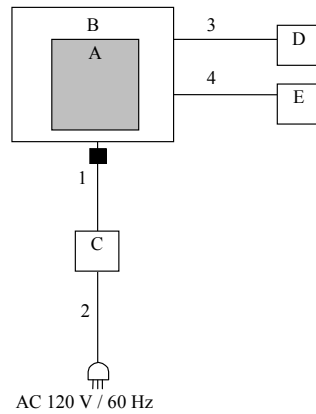

■ : Standard Ferrite Core

* Cabling and setup(s) were taken into consideration and test data was taken under worse case conditions.

Description of EUT and Support equipment

No.	Item	Model number	Serial number	Manufacturer	Remarks
A	Wireless Module	WL13A	*1)	Panasonic	EUT
B	Detachable PC	FZ-Q1	2291BBA05J00067 *2) 2291BBA05J00054 *3)	Panasonic	-
C	AC Adapter	CF-AA6373A M3	6413CM314Y00087A	Panasonic	-
D	USB Mouse	MO56UC	520026409	DELL	-
E	Ear phone	-	-	Panasonic	-

*1) This item controlled with B: Personal Computer.

*2) Used for Antenna Terminal conducted test

*3) Used for all test except for Antenna Terminal conducted test

List of cables used

No.	Name	Length (m)	Shield		Remarks
			Cable	Connector	
1	DC Cable	1.1	Shielded	Shielded	-
2	AC Cable	1.9	Unshielded	Unshielded	-
3	USB Cable	1.8	Shielded	Shielded	-
4	Audio Cable	0.9	Shielded	Shielded	-

UL Japan, Inc.

Ise EMC Lab.

4383-326 Asama-cho, Ise-shi, Mie-ken 516-0021 JAPAN

Telephone : +81 596 24 8999

Facsimile : +81 596 24 8124

SECTION 5: Conducted Emission

Test Procedure and conditions

EUT was placed on a urethane platform of nominal size, 1.0 m by 1.5 m, raised 0.8 m above the conducting ground plane.

The rear of tabletop was located 40cm to the vertical conducting plane. The rear of EUT, including peripherals aligned and flushed with rear of tabletop. All other surfaces of tabletop were at least 80cm from any other grounded conducting surface. EUT was located 80cm from a Line Impedance Stabilization Network (LISN) / Artificial mains Network (AMN) and excess AC cable was bundled in center.

For the tests on EUT with other peripherals (as a whole system)

I/O cables that were connected to the peripherals were bundled in center. They were folded back and forth forming a bundle 30 cm to 40 cm long and were hanged at a 40 cm height to the ground plane. All unused 50 ohm connectors of the LISN (AMN) were resistivity terminated in 50 ohm when not connected to the measuring equipment.

The AC Mains Terminal Continuous disturbance Voltage has been measured with the EUT in a Semi Anechoic Chamber.

The EUT was connected to a LISN (AMN).

An overview sweep with peak detection has been performed.

The test results and limit are rounded off to one decimal place, so some differences might be observed.

Detector : QP and CISPR Average
Measurement range : 0.15 MHz-30 MHz
Test data : APPENDIX
Test result : Pass

SECTION 6: Radiated Spurious Emission and Band Edge Compliance

Test Procedure

[For below 1GHz]

EUT was placed on a urethane platform of nominal size, 0.5 m by 1.0 m, raised 0.8 m above the conducting ground plane. The Radiated Electric Field Strength has been measured in a Semi Anechoic Chamber with a ground plane.

[For above 1GHz]

EUT was placed on a urethane platform of nominal size, 0.5 m by 0.5 m, raised 1.5 m above the conducting ground plane.

The Radiated Electric Field Strength has been measured in a Semi Anechoic Chamber with absorbent materials lined on a ground plane.

The height of the measuring antenna varied between 1 and 4 m and EUT was rotated a full revolution in order to obtain the maximum value of the electric field strength.

The measurements were performed for both vertical and horizontal antenna polarization with the Test Receiver, or the Spectrum Analyzer.

The measurements were made with the following detector function of the test receiver and the Spectrum analyzer (in linear mode).

The test was made with the detector (RBW/VBW) in the following table.

When using Spectrum analyzer, the test was made with adjusting span to zero by using peak hold.

< Below 1GHz >

The result also satisfied with the general limits specified in section 15.209 (a).

< Above 1GHz >

Inside of restricted bands (Section 15.205):

Apply to limit in the Section 15.209 (a).

Outside of the restricted bands:

Apply to limit 68.2 dBuV/m, 3 m (-27 dBm e.i.r.p.*) in the Section 15.407 (b) (1) (2) (3).

Apply to limit 68.2 dBuV/m, 3 m (-27 dBm e.i.r.p.*) or

78.2 dBuV/m, 3 m (-17 dBm e.i.r.p.*) in the Section 15.407 (b).

Restricted band edge:

Apply to limit in the Section 15.209 (a).

Since this limit is severer than the limit of the inside of restricted bands.

*Electric field strength to e.i.r.p. conversion:

$$E = \frac{1000000\sqrt{30P}}{3} \text{ (uV/m)} \quad :P \text{ is the e.i.r.p. (Watts)}$$

Test Antennas are used as below;

Frequency	30 MHz to 300 MHz	300 MHz to 1 GHz	Above 1 GHz
Antenna Type	Biconical	Logperiodic	Horn

Frequency	Below 1 GHz	Above 1 GHz	
Instrument used	Test Receiver	Spectrum Analyzer	
Detector	QP	Peak	Average
IF Bandwidth	BW: 120 kHz	RBW: 1 MHz VBW: 3 MHz	Method AD *1) RBW: 1 MHz VBW: 3 MHz Detector: Power Averaging (RMS) Trace: ≥ 100 traces Duty factor was added to the results.
Test Distance	3 m	3 m (below 10 GHz), 1 m*2) (above 10 GHz), 0.5 m*3) (above 26.5 GHz)	

*1) The test method was also referred to KDB 789033 D02 General UNII Test Procedures New Rules v01 "Guidelines for Compliance Testing of Unlicensed National Information Infrastructure (U-NII) Devices Part 15, Subpart E (Issued on June 6, 2014)".

*2) Distance Factor: $20 \times \log(3.0 \text{ m}/1.0 \text{ m}) = 9.5 \text{ dB}$

*3) Distance Factor: $20 \times \log(3.0 \text{ m}/0.5 \text{ m}) = 15.6 \text{ dB}$

- The carrier level and noise levels were confirmed at each position of X, Y and Z axes of EUT to see the position of maximum noise, and the test was made at the position that has the maximum noise.

The test results and limit are rounded off to one decimal place, so some differences might be observed.

Measurement range : 30 MHz-40 GHz
Test data : APPENDIX
Test result : Pass

UL Japan, Inc.

Ise EMC Lab.

4383-326 Asama-cho, Ise-shi, Mie-ken 516-0021 JAPAN

Telephone : +81 596 24 8999

Facsimile : +81 596 24 8124

SECTION 7: Antenna Terminal Conducted Tests

Test Procedure

The tests were made with below setting connected to the antenna port.

Test	Span	RBW	VBW	Sweep time	Detector	Trace	Instrument used and Test method
99 % Occupied Bandwidth *1)	Enough width to display emission skirts	1 % to 5 % of OBW	≥ 3 RBW	Auto	Peak	Max Hold	Spectrum Analyzer
6 dB Bandwidth	Enough to capture the emission	100 kHz	300 kHz	Auto	Peak	Max Hold	Spectrum Analyzer
Maximum Conducted Output Power	-	-	-	Auto	Average	-	Power Meter (Sensor: 80 MHz BW) (Method PM-G)
Maximum Power Spectral Density	Encompass the entire EBW	470 kHz *2)	≥ 3 RBW	Auto	RMS or Sample Power Averaging (200 times)	Clear Write	Spectrum Analyzer
Conducted Spurious Emission*3)	9 kHz – 150 kHz	200 Hz	620 Hz	Auto	Peak	Max Hold	Spectrum Analyzer
	150 kHz – 30 MHz	9.1 kHz	27 kHz				

* The test method was also referred to KDB 789033 D02 General UNII Test Procedures New Rules v01 "Guidelines for Compliance Testing of Unlicensed National Information Infrastructure (U-NII) Devices Part 15, Subpart E (Issued on June 6, 2014)".

*1) Peak hold was applied as Worst-case measurement.

*2) FCC standard says that RBW is set to be 500 kHz for 5.725 GHz-5.850 GHz, but it is not possible with spectrum analyzer, so $10\log(500\text{ kHz}/470\text{ kHz})$ was added to the test result.

*3) In the frequency range below 30 MHz, RBW was narrowed to separate the noise contents.

Then, wide-band noise near the limit was checked separately, however the noise was low enough as shown in the chart. (9 kHz-150 kHz: RBW = 200 Hz, 150 kHz-30 MHz: RBW = 9.1 kHz).

The test results and limit are rounded off to two decimals place, so some differences might be observed.

Test data : APPENDIX
Test result : Pass

APPENDIX 1: Test data

Conducted Emission

DATA OF CONDUCTED EMISSION TEST

UL Japan, Inc. Ise EMC Lab. No. 2 Semi Anechoic Chamber
 Date : 2015/12/13

Report No. : 11018663H
 Temp./Humi. : 23deg. C / 40% RH
 Engineer : Shinichi Miyazono

Mode / Remarks : WLAN Tx 11ac80 5775MHz

LIMIT : FCC15.207 QP
 FCC15.207 AV

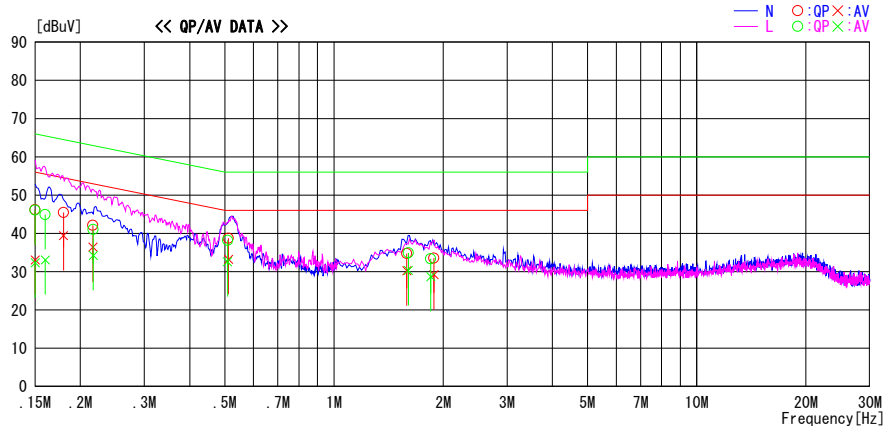

Frequency [MHz]	Reading Level		Corr. Factor	Results		Limit		Margin		Phase	Comment
	QP [dBuV]	AV [dBuV]		QP [dBuV]	AV [dBuV]	QP [dBuV]	AV [dBuV]	QP [dB]	AV [dB]		
0.15000	33.0	19.9	13.2	46.2	33.1	66.0	56.0	19.8	22.9	N	
0.17970	32.3	26.2	13.2	45.5	39.4	64.5	54.5	19.0	15.1	N	
0.21650	28.9	23.2	13.2	42.1	36.4	63.0	53.0	20.9	16.6	N	
0.51200	25.5	20.0	13.2	38.7	33.2	56.0	46.0	17.3	12.8	N	
1.58800	21.3	16.8	13.4	34.7	30.2	56.0	46.0	21.3	15.8	N	
1.88600	20.2	15.8	13.4	33.6	29.2	56.0	46.0	22.4	16.8	N	
0.15000	32.9	19.1	13.2	46.1	32.3	66.0	56.0	19.9	23.7	L	
0.15990	31.7	19.9	13.2	44.9	33.1	65.5	55.5	20.6	22.4	L	
0.21680	27.8	21.0	13.2	41.0	34.2	62.9	52.9	21.9	18.7	L	
0.50900	25.0	19.4	13.2	38.2	32.6	56.0	46.0	17.8	13.4	L	
1.60400	21.5	16.9	13.4	34.9	30.3	56.0	46.0	21.1	15.7	L	
1.84800	20.0	15.3	13.4	33.4	28.7	56.0	46.0	22.6	17.3	L	

CHART : WITH FACTOR, Peak hold data. CALCULATION : RESULT = READING + C.F (LISN + ATTEN. + CABLE)
 Except for the above table : adequate margin data below the limits.

99 % Occupied Bandwidth

Test place Ise EMC Lab. No.7 Shielded Room
Report No. 11220705H
Date November 24, 2015
Temperature / Humidity 23deg. C / 45 % RH
Engineer Tsubasa Takayama
Mode Tx 11a

11a

Antenna	Tested Frequency [MHz]	26 dB Emission Bandwidth [MHz]	99 % Occupied Bandwidth [MHz]	Limit [MHz]
Antenna A	5745	-	17.288	-
	5785	-	17.321	-
	5825	-	17.288	-

Antenna	Tested Frequency [MHz]	26 dB Emission Bandwidth [MHz]	99 % Occupied Bandwidth [MHz]	Limit [MHz]
Antenna B	5745	-	17.296	-
	5785	-	17.279	-
	5825	-	17.259	-

99 % Occupied Bandwidth

Test place Ise EMC Lab. No.7 Shielded Room
Report No. 11220705H
Date November 24, 2015
Temperature / Humidity 23deg. C / 45 % RH
Engineer Tsubasa Takayama
Mode Tx 11ac-20

11ac-20

Antenna	Tested Frequency [MHz]	26 dB Emission Bandwidth [MHz]	99 % Occupied Bandwidth [MHz]	Limit [MHz]
Antenna A	5745	-	18.642	-
	5785	-	18.743	-
	5825	-	18.725	-

Antenna	Tested Frequency [MHz]	26 dB Emission Bandwidth [MHz]	99 % Occupied Bandwidth [MHz]	Limit [MHz]
Antenna B	5745	-	18.674	-
	5785	-	18.685	-
	5825	-	18.590	-

99 % Occupied Bandwidth

Test place Ise EMC Lab. No.7 Shielded Room
Report No. 11220705H
Date November 24, 2015
Temperature / Humidity 23deg. C / 45 % RH
Engineer Tsubasa Takayama
Mode Tx 11ac-40

11ac-40

Antenna	Tested Frequency [MHz]	26 dB Emission Bandwidth [MHz]	99 % Occupied Bandwidth [MHz]	Limit [MHz]
Antenna A	5755	-	36.202	-
	5795	-	36.247	-

Antenna	Tested Frequency [MHz]	26 dB Emission Bandwidth [MHz]	99 % Occupied Bandwidth [MHz]	Limit [MHz]
Antenna B	5755	-	36.084	-
	5795	-	36.203	-

99 % Occupied Bandwidth

Test place Ise EMC Lab. No.7 Shielded Room
Report No. 11220705H
Date November 24, 2015
Temperature / Humidity 23deg. C / 45 % RH
Engineer Tsubasa Takayama
Mode Tx 11ac-80

11ac-80

Antenna	Tested Frequency [MHz]	26 dB Emission Bandwidth [MHz]	99 % Occupied Bandwidth [MHz]	Limit [MHz]
Antenna A	5775	-	74.973	-

Antenna	Tested Frequency [MHz]	26 dB Emission Bandwidth [MHz]	99 % Occupied Bandwidth [MHz]	Limit [MHz]
Antenna B	5775	-	74.759	-

99 % Occupied Bandwidth

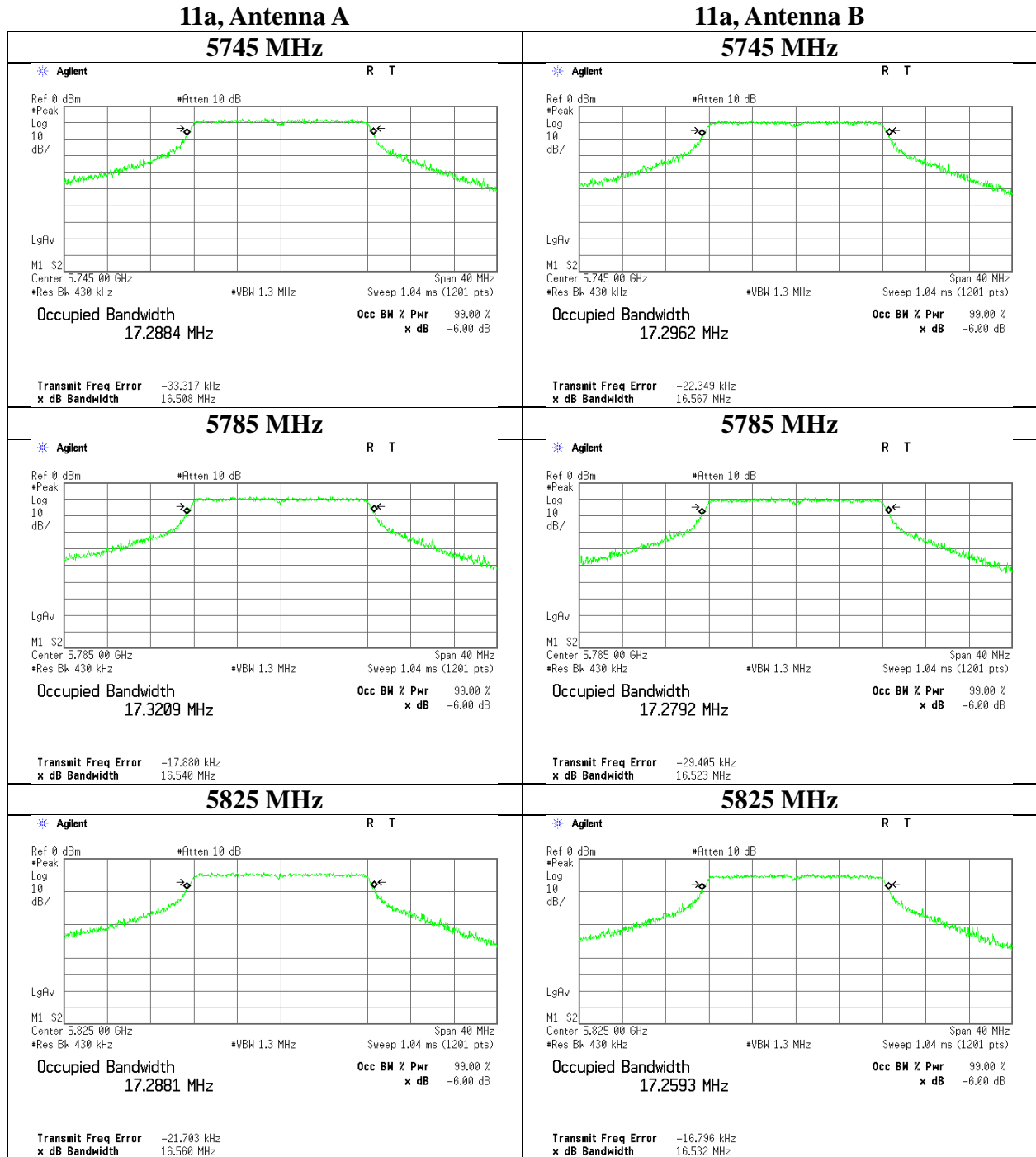

99 % Occupied Bandwidth

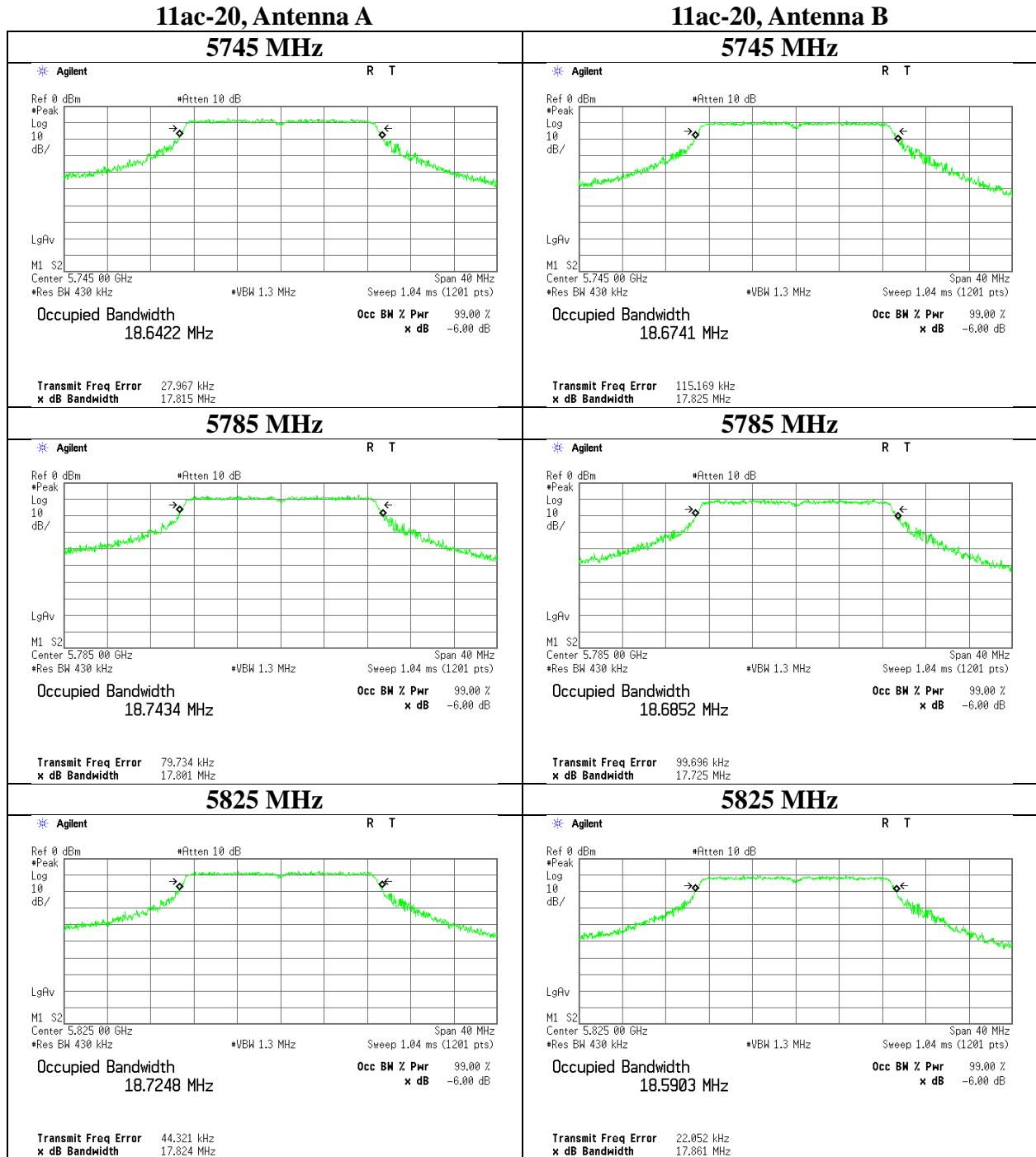

UL Japan, Inc.

Ise EMC Lab.

4383-326 Asama-cho, Ise-shi, Mie-ken 516-0021 JAPAN

Telephone : +81 596 24 8999

Facsimile : +81 596 24 8124

99 % Occupied Bandwidth

11ac-40, Antenna A

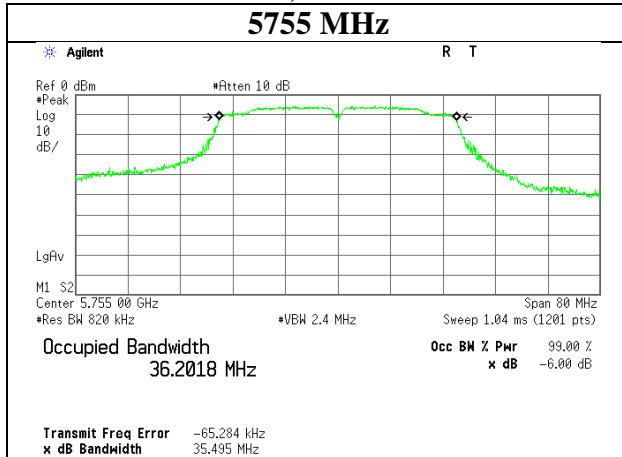

11ac-40, Antenna B

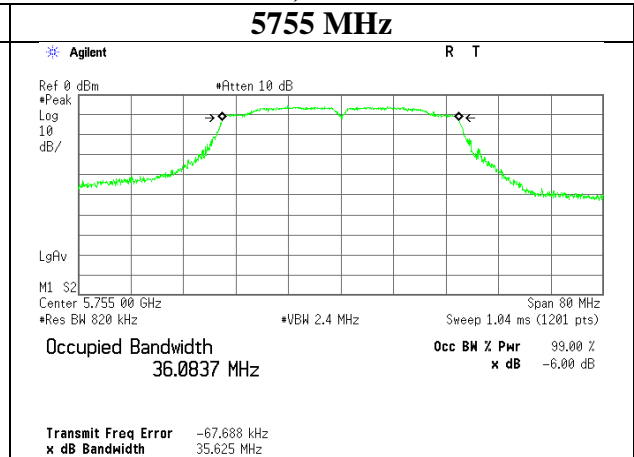

5795 MHz

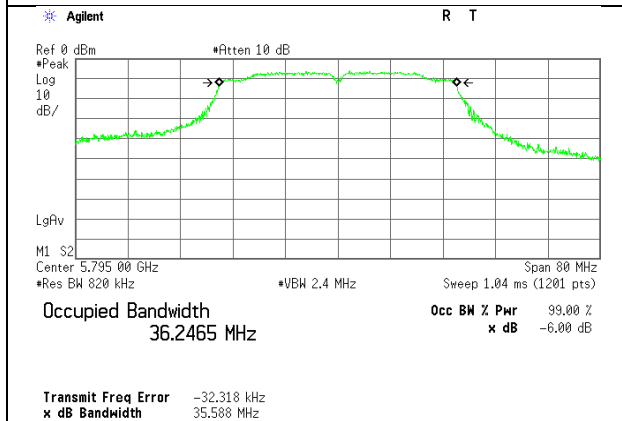

5795 MHz

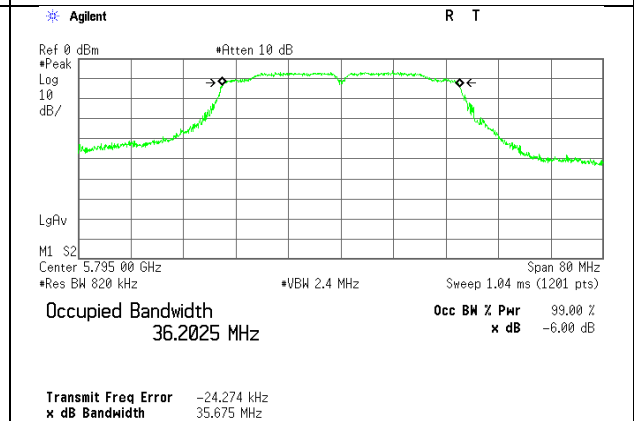

99 % Occupied Bandwidth

11ac-80, Antenna A

5775 MHz

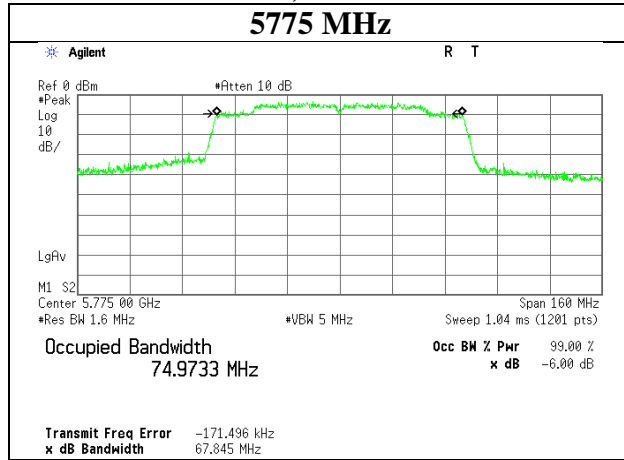

11ac-80, Antenna B

5775 MHz

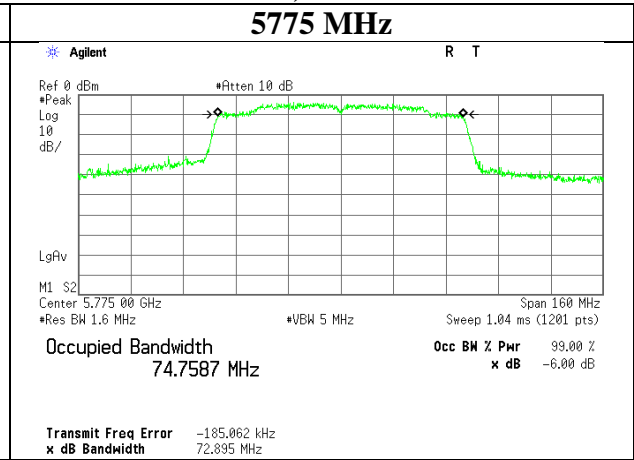

UL Japan, Inc.

Ise EMC Lab.

4383-326 Asama-cho, Ise-shi, Mie-ken 516-0021 JAPAN

Telephone : +81 596 24 8999

Facsimile : +81 596 24 8124

6 dB Bandwidth

Test place Ise EMC Lab. No.7 Shielded Room
Report No. 11220705H
Date November 24, 2015
Temperature / Humidity 23deg. C / 45 % RH
Engineer Tsubasa Takayama
Mode Tx 11a, 11ac-20

11a

Antenna	Tested Frequency [MHz]	6 dB Bandwidth [MHz]	Limit [kHz]
Antenna A	5745	16.339	> 500
	5785	16.379	> 500
	5825	16.366	> 500

Antenna	Tested Frequency [MHz]	6 dB Bandwidth [MHz]	Limit [kHz]
Antenna B	5745	16.381	> 500
	5785	16.378	> 500
	5825	16.349	> 500

11ac-20

Antenna	Tested Frequency [MHz]	6 dB Bandwidth [MHz]	Limit [kHz]
Antenna A	5745	17.597	> 500
	5785	17.643	> 500
	5825	17.603	> 500

Antenna	Tested Frequency [MHz]	6 dB Bandwidth [MHz]	Limit [kHz]
Antenna B	5745	17.607	> 500
	5785	17.618	> 500
	5825	17.602	> 500

6 dB Bandwidth

Test place Ise EMC Lab. No.7 Shielded Room
Report No. 11220705H
Date November 24, 2015
Temperature / Humidity 23deg. C / 45 % RH
Engineer Tsubasa Takayama
Mode Tx 11ac-40, 11ac-80

11ac-40

Antenna	Tested Frequency [MHz]	6 dB Bandwidth [MHz]	Limit [kHz]
Antenna A	5755	35.120	> 500
	5795	35.131	> 500

Antenna	Tested Frequency [MHz]	6 dB Bandwidth [MHz]	Limit [kHz]
Antenna B	5755	35.136	> 500
	5795	35.129	> 500

11ac-80

Antenna	Tested Frequency [MHz]	6 dB Bandwidth [MHz]	Limit [kHz]
Antenna A	5775	75.226	> 500

Antenna	Tested Frequency [MHz]	6 dB Bandwidth [MHz]	Limit [kHz]
Antenna B	5775	75.132	> 500

6 dB Bandwidth

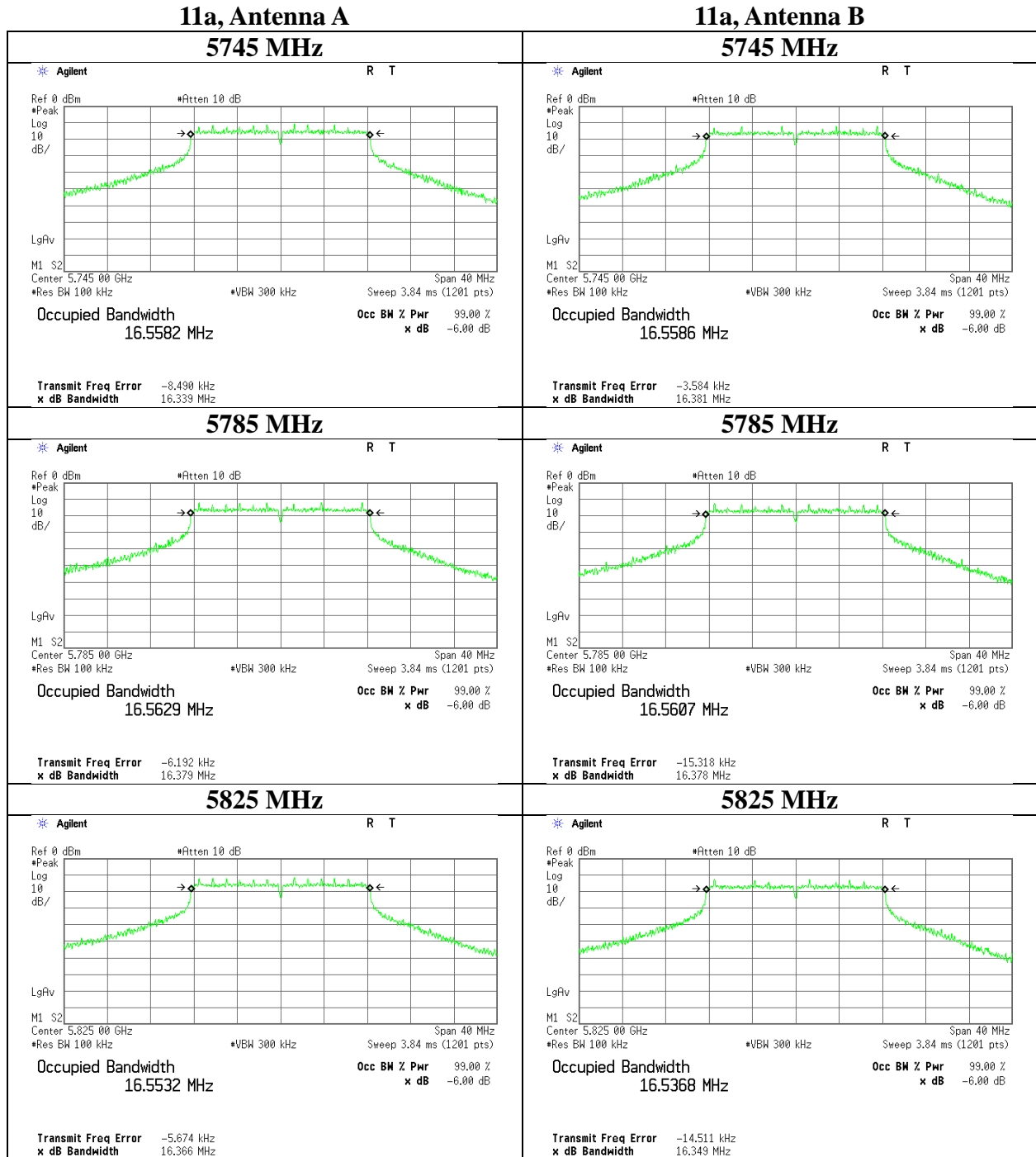

6 dB Bandwidth

11ac-20, Antenna A

11ac-20, Antenna B

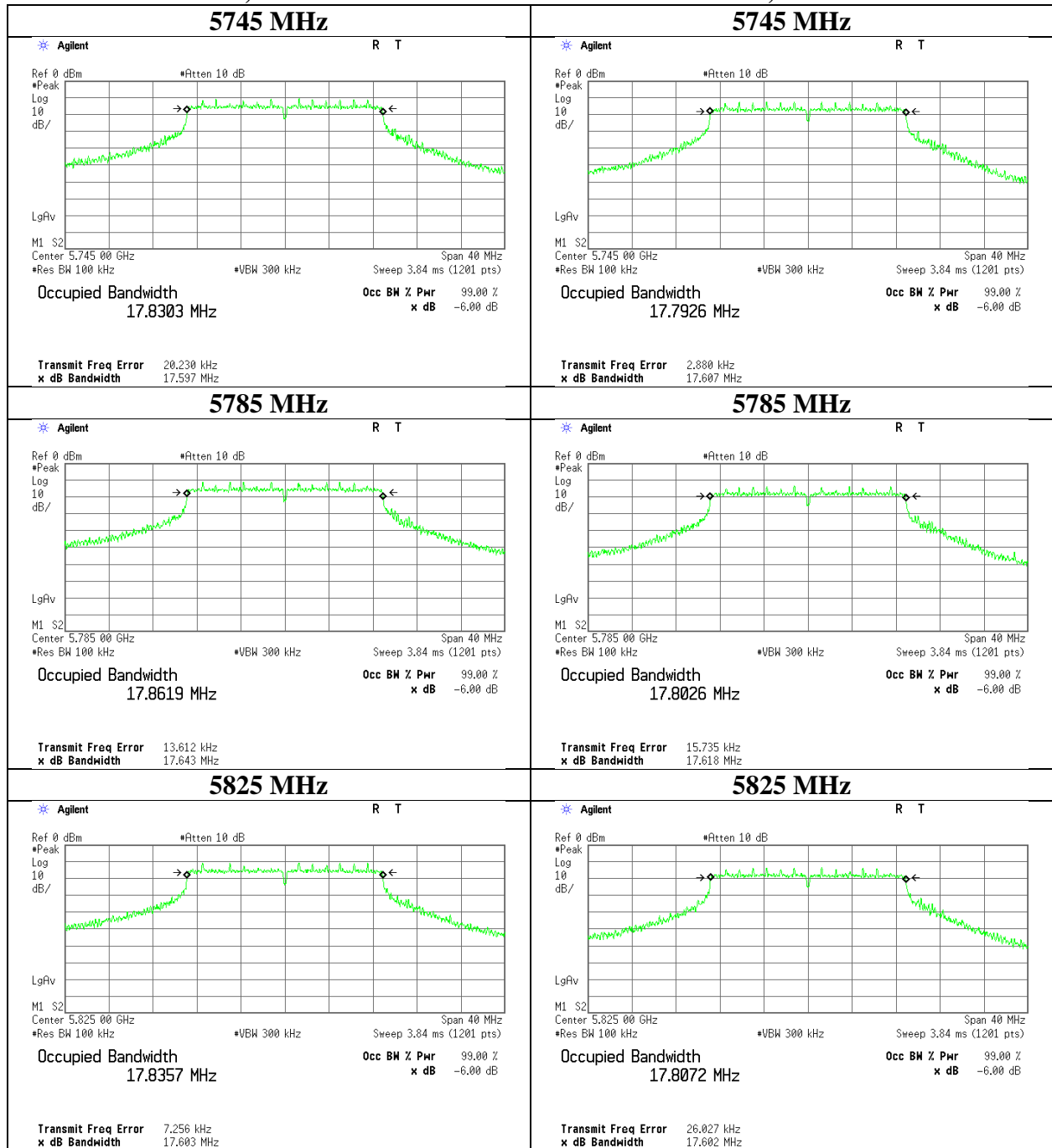

UL Japan, Inc.

Ise EMC Lab.

4383-326 Asama-cho, Ise-shi, Mie-ken 516-0021 JAPAN

Telephone : +81 596 24 8999

Facsimile : +81 596 24 8124

6 dB Bandwidth

11ac-40, Antenna A

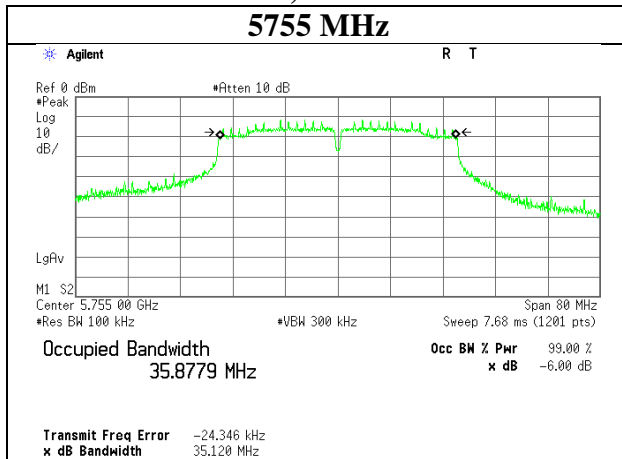

11ac-40, Antenna B

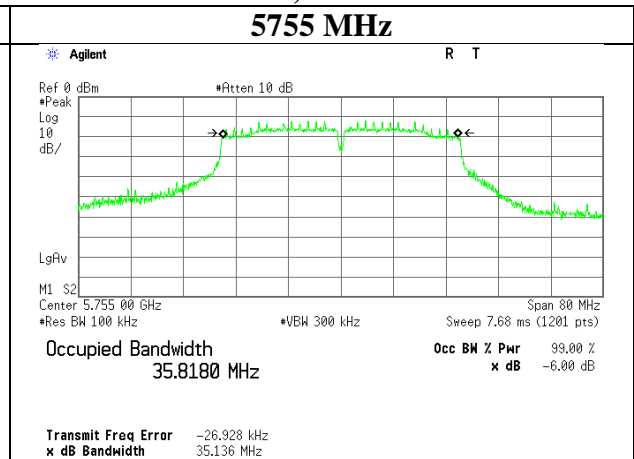

5795 MHz

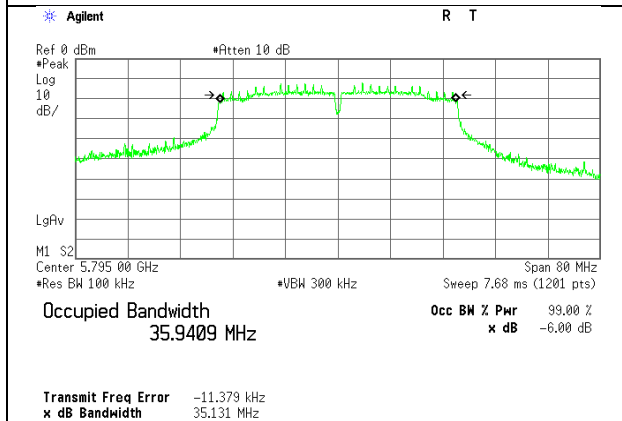

5795 MHz

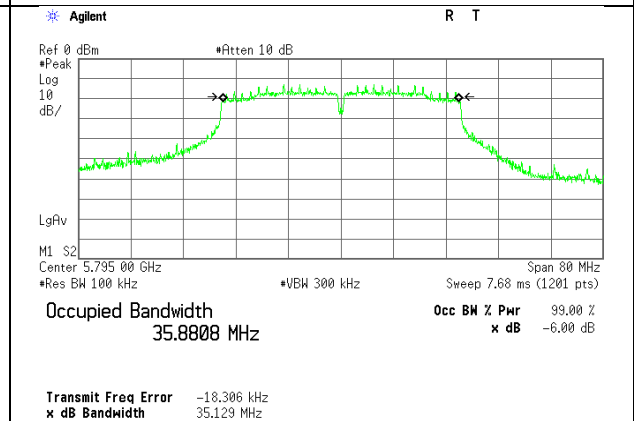

6 dB Bandwidth

11ac-80, Antenna A

5775 MHz

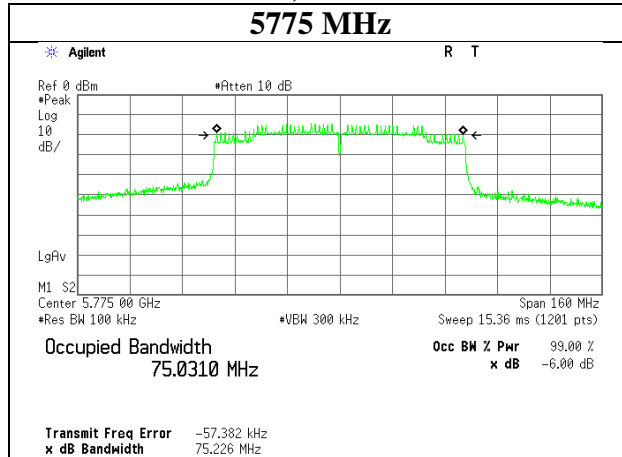

11ac-80, Antenna B

5775 MHz

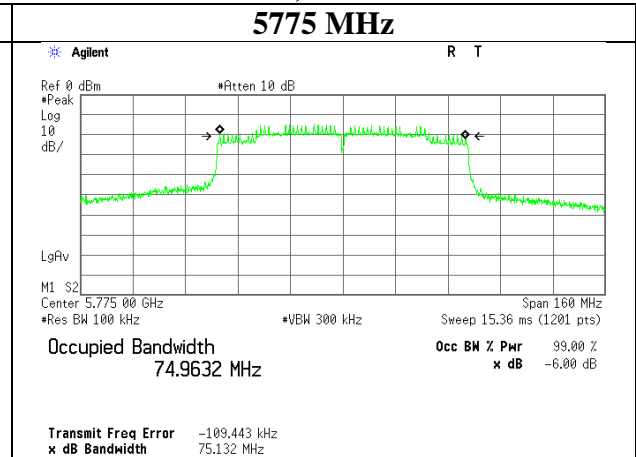

Maximum Conducted Output Power

Test place	Ise EMC Lab. No.6 Measurement Room	
Report No.	11220705H	
Date	December 18, 2015	January 26, 2016
Temperature / Humidity	23deg. C / 40 % RH	23deg. C / 31 % RH
Engineer	Tsubasa Takayama	Yutaka Yoshida
Mode	Tx 11a	

Antenna A

Tested Frequency [MHz]	Power Meter Reading [dBm]	Cable Loss [dB]	Atten. Loss [dB]	Duty Factor [dB]	Antenna Gain [dBi]	Result		Limit [dBm]	Margin [dB]
						[dBm]	[mW]		
5745	1.95	1.84	10.10	0.00	-	13.89	24.50	30.00	16.11
5785	1.86	1.84	10.10	0.00	-	13.81	24.03	30.00	16.19
5825	1.85	1.85	10.10	0.00	-	13.80	24.00	30.00	16.20

Sample Calculation:

Power Result = Reading + Cable Loss + Atten. Loss

Conducted Power Limit (5750 MHz-5825 MHz) = 1W (30dBm)

Antenna B

Tested Frequency [MHz]	Power Meter Reading [dBm]	Cable Loss [dB]	Atten. Loss [dB]	Duty Factor [dB]	Antenna Gain [dBi]	Result		Limit [dBm]	Margin [dB]
						[dBm]	[mW]		
5745	2.41	1.84	10.10	0.00	-	14.35	27.24	30.00	15.65
5785	2.51	1.84	10.10	0.00	-	14.46	27.91	30.00	15.54
5825	2.49	1.85	10.10	0.00	-	14.44	27.82	30.00	15.56

Sample Calculation:

Power Result = Reading + Cable Loss + Atten. Loss

Conducted Power Limit (5750 MHz-5825 MHz) = 1W (30dBm)

Maximum Conducted Output Power

Test place	Ise EMC Lab. No.6 Measurement Room	
Report No.	11220705H	
Date	December 18, 2015	January 26, 2016
Temperature / Humidity	23deg. C / 40 % RH	23deg. C / 31 % RH
Engineer	Tsubasa Takayama	Yutaka Yoshida
Mode	Tx 11n-20	

Antenna A

Tested Frequency [MHz]	Power Meter Reading [dBm]	Cable Loss [dB]	Atten. Loss [dB]	Duty Factor [dB]	Antenna Gain [dBi]	Result		Limit [dBm]	Margin [dB]
						[dBm]	[mW]		
5745	2.28	1.53	10.04	0.00	-	13.85	24.27	30.00	16.15
5785	2.09	1.54	10.04	0.00	-	13.67	23.28	30.00	16.33
5825	2.04	1.85	10.10	0.00	-	13.99	25.08	30.00	16.01

Sample Calculation:

Power Result = Reading + Cable Loss + Atten. Loss

Conducted Power Limit (5750 MHz-5825 MHz) = 1W (30dBm)

Antenna B

Tested Frequency [MHz]	Power Meter Reading [dBm]	Cable Loss [dB]	Atten. Loss [dB]	Duty Factor [dB]	Antenna Gain [dBi]	Result		Limit [dBm]	Margin [dB]
						[dBm]	[mW]		
5745	2.67	1.53	10.18	0.00	-	14.38	27.42	30.00	15.62
5785	2.73	1.54	10.18	0.00	-	14.45	27.86	30.00	15.55
5825	2.51	1.85	10.10	0.00	-	14.46	27.94	30.00	15.54

Sample Calculation:

Power Result = Reading + Cable Loss + Atten. Loss

Conducted Power Limit (5750 MHz-5825 MHz) = 1W (30dBm)

UL Japan, Inc.

Ise EMC Lab.

4383-326 Asama-cho, Ise-shi, Mie-ken 516-0021 JAPAN

Telephone : +81 596 24 8999

Facsimile : +81 596 24 8124

Maximum Conducted Output Power

Test place	Ise EMC Lab. No.6 Measurement Room	
Report No.	11220705H	
Date	December 20, 2015	January 26, 2016
Temperature / Humidity	21deg. C / 42 % RH	23deg. C / 31 % RH
Engineer	Satofumi Matsuyama	Yutaka Yoshida
Mode	Tx 11n-20	

Antenna A+B

Tested Frequency [MHz]	Antenna			Result [dBm]	Limit [dBm]	Margin [dB]
	1 [mW]	2 [mW]	Sum [mW]			
5745	15.78	15.75	31.53	14.99	30.00	15.01
5785	15.59	15.80	31.39	14.97	30.00	15.03
5825	15.64	15.71	31.36	14.96	30.00	15.04

Tested Frequency [MHz]	Duty Factor [dB]	Antenna A				Result Power [dBm]	Antenna B				Result Power [dBm]
		Power Meter Reading [dBm]	Cable Loss [dB]	Atten. Loss [dB]	Antenna Gain [dBi]		Power Meter Reading [dBm]	Cable Loss [dB]	Atten. Loss [dB]	Antenna Gain [dBi]	
5745	0.00	0.04	1.84	10.10	-	11.98	0.03	1.84	10.10	-	11.97
5785	0.00	-0.02	1.84	10.10	-	11.93	0.04	1.84	10.10	-	11.99
5825	0.00	-0.01	1.85	10.10	-	11.94	0.01	1.85	10.10	-	11.96

Sample Calculation:

Power Result = Reading + Cable Loss + Atten. Loss

Conducted Power Limit (5750 MHz-5825 MHz) = 1W (30dBm)

UL Japan, Inc.

Ise EMC Lab.

4383-326 Asama-cho, Ise-shi, Mie-ken 516-0021 JAPAN

Telephone : +81 596 24 8999

Facsimile : +81 596 24 8124

Maximum Conducted Output Power

Test place	Ise EMC Lab. No.6 Measurement Room	
Report No.	11220705H	
Date	December 18, 2015	January 26, 2016
Temperature / Humidity	23deg. C / 40 % RH	23deg. C / 31 % RH
Engineer	Tsubasa Takayama	Yutaka Yoshida
Mode	Tx 11ac-20	

Antenna A

Tested Frequency [MHz]	Power Meter Reading [dBm]	Cable Loss [dB]	Atten. Loss [dB]	Duty Factor [dB]	Antenna Gain [dBi]	Result		Limit [dBm]	Margin [dB]
						[dBm]	[mW]		
5745	1.52	1.84	10.10	0.00	-	13.46	22.19	30.00	16.54
5785	1.55	1.84	10.10	0.00	-	13.50	22.37	30.00	16.50
5825	1.49	1.85	10.10	0.00	-	13.44	22.09	30.00	16.56

Sample Calculation:

Power Result = Reading + Cable Loss + Atten. Loss

Conducted Power Limit (5750 MHz-5825 MHz) = 1W (30dBm)

Antenna B

Tested Frequency [MHz]	Power Meter Reading [dBm]	Cable Loss [dB]	Atten. Loss [dB]	Duty Factor [dB]	Antenna Gain [dBi]	Result		Limit [dBm]	Margin [dB]
						[dBm]	[mW]		
5745	2.49	1.84	10.10	0.00	-	14.43	27.74	30.00	15.57
5785	2.51	1.84	10.10	0.00	-	14.46	27.91	30.00	15.54
5825	2.53	1.85	10.10	0.00	-	14.48	28.07	30.00	15.52

Sample Calculation:

Power Result = Reading + Cable Loss + Atten. Loss

Conducted Power Limit (5750 MHz-5825 MHz) = 1W (30dBm)

UL Japan, Inc.

Ise EMC Lab.

4383-326 Asama-cho, Ise-shi, Mie-ken 516-0021 JAPAN

Telephone : +81 596 24 8999

Facsimile : +81 596 24 8124

Maximum Conducted Output Power

Test place	Ise EMC Lab. No.6 Measurement Room	
Report No.	11220705H	
Date	December 20, 2015	January 26, 2016
Temperature / Humidity	21deg. C / 42 % RH	23deg. C / 31 % RH
Engineer	Satofumi Matsuyama	Yutaka Yoshida
Mode	Tx 11ac-20	

Antenna A+B

Tested Frequency [MHz]	Antenna			Result [dBm]	Limit [dBm]	Margin [dB]
	1 [mW]	2 [mW]	Sum [mW]			
5745	15.58	15.82	31.40	14.97	30.00	15.03
5785	15.37	14.62	29.99	14.77	30.00	15.23
5825	15.71	15.71	31.43	14.97	30.00	15.03

Tested Frequency [MHz]	Duty Factor [dB]	Antenna A				Result Power [dBm]	Antenna B				Result Power [dBm]
		Power Meter Reading [dBm]	Cable Loss [dB]	Atten. Loss [dB]	Antenna Gain [dBi]		Power Meter Reading [dBm]	Cable Loss [dB]	Atten. Loss [dB]	Antenna Gain [dBi]	
5745	0.00	0.05	1.84	10.04	-	11.93	0.05	1.84	10.10	-	11.99
5785	0.00	-0.08	1.84	10.10	-	11.87	-0.37	1.84	10.18	-	11.65
5825	0.00	0.01	1.85	10.10	-	11.96	0.01	1.85	10.10	-	11.96

Sample Calculation:

Power Result = Reading + Cable Loss + Atten. Loss

Conducted Power Limit (5750 MHz-5825 MHz) = 1W (30dBm)

Maximum Conducted Output Power

Test place	Ise EMC Lab. No.6 Measurement Room		
Report No.	11220705H		
Date	December 18, 2015	January 17, 2016	January 26, 2016
Temperature / Humidity	23deg. C / 40 % RH	22deg. C / 32 % RH	23deg. C / 31 % RH
Engineer	Tsubasa Takayama	Takumi Shimada	Yutaka Yoshida
Mode	Tx 11n-40		

Antenna A

Tested Frequency [MHz]	Power Meter Reading [dBm]	Cable Loss [dB]	Atten. Loss [dB]	Duty Factor [dB]	Antenna Gain [dBi]	Result		Limit [dBm]	Margin [dB]
						[dBm]	[mW]		
5755	1.78	1.84	10.10	0.00	-	13.72	23.56	30.00	16.28
5795	1.66	1.84	10.10	0.00	-	13.61	22.95	30.00	16.39

Sample Calculation:

Power Result = Reading + Cable Loss + Atten. Loss
 Conducted Power Limit (5750 MHz-5825 MHz) = 1W (30dBm)

Antenna B

Tested Frequency [MHz]	Power Meter Reading [dBm]	Cable Loss [dB]	Atten. Loss [dB]	Duty Factor [dB]	Antenna Gain [dBi]	Conducted Power		Limit [dBm]	Margin [dB]
						[dBm]	[mW]		
5755	2.42	1.84	10.10	0.00	-	14.36	27.30	30.00	15.64
5795	2.36	1.84	10.10	0.00	-	14.31	26.96	30.00	15.69

Sample Calculation:

Power Result = Reading + Cable Loss + Atten. Loss
 Conducted Power Limit (5750 MHz-5825 MHz) = 1W (30dBm)

Maximum Conducted Output Power

Test place	Ise EMC Lab. No.6 Measurement Room		
Report No.	11220705H		
Date	December 20, 2015	January 17, 2016	January 26, 2016
Temperature / Humidity	21deg. C / 42 % RH	22deg. C / 32 % RH	23deg. C / 31 % RH
Engineer	Satofumi Matsuyama	Takumi Shimada	Yutaka Yoshida
Mode	Tx 11n-40		

Antenna A+B

Tested Frequency [MHz]	Antenna			Result [dBm]	Limit [dBm]	Margin [dB]
	1 [mW]	2 [mW]	Sum [mW]			
5755	17.79	17.63	35.41	15.49	30.00	14.51
5795	17.71	17.70	35.41	15.49	30.00	14.51

Antenna A							Antenna B				
Tested Frequency [MHz]	Duty Factor [dB]	Power Meter Reading [dBm]	Cable Loss [dB]	Atten. Loss [dB]	Antenna Gain [dBi]	Result Power [dBm]	Power Meter Reading [dBm]	Cable Loss [dB]	Atten. Loss [dB]	Antenna Gain [dBi]	Result Power [dBm]
5755	0.00	0.56	1.84	10.10	-	12.50	0.52	1.84	10.10	-	12.46
5795	0.00	0.53	1.85	10.10	-	12.48	0.76	1.54	10.18	-	12.48

Sample Calculation:

Power Result = Reading + Cable Loss + Atten. Loss

Conducted Power Limit (5750 MHz-5825 MHz) = 1W (30dBm)

Maximum Conducted Output Power

Test place	Ise EMC Lab. No.6 Measurement Room		
Report No.	11220705H		
Date	December 18, 2015	January 17, 2016	January 26, 2016
Temperature / Humidity	23deg. C / 40 % RH	22deg. C / 32 % RH	23deg. C / 31 % RH
Engineer	Tsubasa Takayama	Takumi Shimada	Yutaka Yoshida
Mode	Tx 11ac-40		

Antenna A

Tested Frequency [MHz]	Power Meter Reading [dBm]	Cable Loss [dB]	Atten. Loss [dB]	Duty Factor [dB]	Antenna Gain [dBi]	Result		Limit [dBm]	Margin [dB]
						[dBm]	[mW]		
5755	2.15	1.54	10.04	0.00	-	13.73	23.60	30.00	16.27
5795	2.39	1.54	10.04	0.00	-	13.97	24.95	30.00	16.03

Sample Calculation:

Power Result = Reading + Cable Loss + Atten. Loss

Conducted Power Limit (5750 MHz-5825 MHz) = 1W (30dBm)

Antenna B

Tested Frequency [MHz]	Power Meter Reading [dBm]	Cable Loss [dB]	Atten. Loss [dB]	Duty Factor [dB]	Antenna Gain [dBi]	Result		Limit [dBm]	Margin [dB]
						[dBm]	[mW]		
5755	2.47	1.84	10.10	0.00	-	14.41	27.62	30.00	15.59
5795	2.51	1.84	10.10	0.00	-	14.46	27.91	30.00	15.54

Sample Calculation:

Power Result = Reading + Cable Loss + Atten. Loss

Conducted Power Limit (5750 MHz-5825 MHz) = 1W (30dBm)

UL Japan, Inc.

Ise EMC Lab.

4383-326 Asama-cho, Ise-shi, Mie-ken 516-0021 JAPAN

Telephone : +81 596 24 8999

Facsimile : +81 596 24 8124

Maximum Conducted Output Power

Test place	Ise EMC Lab. No.6 Measurement Room		
Report No.	11220705H		
Date	December 20, 2015	January 17, 2016	January 26, 2016
Temperature / Humidity	21deg. C / 42 % RH	22deg. C / 32 % RH	23deg. C / 31 % RH
Engineer	Satofumi Matsuyama	Takumi Shimada	Yutaka Yoshida
Mode	Tx 11ac-40		

Antenna A+B

Tested Frequency [MHz]	Antenna			Result [dBm]	Limit [dBm]	Margin [dB]
	1 [mW]	2 [mW]	Sum [mW]			
5755	17.54	17.79	35.33	15.48	30.00	14.52
5795	17.67	17.71	35.38	15.49	30.00	14.51

Antenna A							Antenna B				
Tested Frequency [MHz]	Duty Factor [dB]	Power Meter Reading [dBm]	Cable Loss [dB]	Atten. Loss [dB]	Antenna Gain [dBi]	Result Power [dBm]	Power Meter Reading [dBm]	Cable Loss [dB]	Atten. Loss [dB]	Antenna Gain [dBi]	Result Power [dBm]
5755	0.00	0.50	1.84	10.10	-	12.44	0.56	1.84	10.10	-	12.50
5795	0.00	0.52	1.85	10.10	-	12.47	0.53	1.85	10.10	-	12.48

Sample Calculation:

Power Result = Reading + Cable Loss + Atten. Loss

Conducted Power Limit (5750 MHz-5825 MHz) = 1W (30dBm)

Maximum Conducted Output Power

Test place	Ise EMC Lab. No.6 Measurement Room	
Report No.	11220705H	
Date	December 18, 2015	January 26, 2016
Temperature / Humidity	23deg. C / 40 % RH	23deg. C / 31 % RH
Engineer	Tsubasa Takayama	Yutaka Yoshida
Mode	Tx 11ac-80	

Antenna A

Tested Frequency [MHz]	Power Meter Reading [dBm]	Cable Loss [dB]	Atten. Loss [dB]	Duty Factor [dB]	Antenna Gain [dBi]	Result		Limit [dBm]	Margin [dB]
						[dBm]	[mW]		
5775	2.24	1.54	10.04	0.00	-	13.82	24.10	30.00	16.18

Sample Calculation:

Power Result = Reading + Cable Loss + Atten. Loss

Conducted Power Limit (5750 MHz-5825 MHz) = 1W (30dBm)

Antenna B

Tested Frequency [MHz]	Power Meter Reading [dBm]	Cable Loss [dB]	Atten. Loss [dB]	Duty Factor [dB]	Antenna Gain [dBi]	Result		Limit [dBm]	Margin [dB]
						[dBm]	[mW]		
5775	0.55	1.84	10.10	0.00	-	12.50	17.77	30.00	17.50

Sample Calculation:

Power Result = Reading + Cable Loss + Atten. Loss

Conducted Power Limit (5750 MHz-5825 MHz) = 1W (30dBm)

Maximum Conducted Output Power

Test place	Ise EMC Lab. No.6 Measurement Room		
Report No.	11220705H		
Date	December 20, 2015	January 17, 2016	January 26, 2016
Temperature / Humidity	21deg. C / 42 % RH	22deg. C / 32 % RH	23deg. C / 31 % RH
Engineer	Satofumi Matsuyama	Takumi Shimada	Yutaka Yoshida
Mode	Tx 11ac-80		

Antenna A+B

Applied limit: 15.407, mobile and portable client device

Tested Frequency [MHz]	Antenna			Result [dBm]	Limit [dBm]	Margin [dB]
	1 [mW]	2 [mW]	Sum [mW]			
5775	17.58	17.65	35.23	15.47	30.00	14.53

Tested Frequency [MHz]	Duty Factor [dB]	Antenna A					Antenna B				
		Power Meter Reading [dBm]	Cable Loss [dB]	Atten. Loss [dB]	Antenna Gain [dBi]	Result Power [dBm]	Power Meter Reading [dBm]	Cable Loss [dB]	Atten. Loss [dB]	Antenna Gain [dBi]	Result Power [dBm]
5775	0.00	0.87	1.54	10.04	-	12.45	0.52	1.84	10.10	-	12.47

Sample Calculation:

Power Result = Reading + Cable Loss + Atten. Loss

Conducted Power Limit (5750 MHz-5825 MHz) = 1W (30dBm)

UL Japan, Inc.

Ise EMC Lab.

4383-326 Asama-cho, Ise-shi, Mie-ken 516-0021 JAPAN

Telephone : +81 596 24 8999

Facsimile : +81 596 24 8124

Burst rate confirmation

Test place	Ise EMC Lab. No.7 Shielded Room
Report No.	11220705H
Date	November 24, 2015
Temperature / Humidity	23deg. C / 45 % RH
Engineer	Tsubasa Takayama

11a 6Mbps

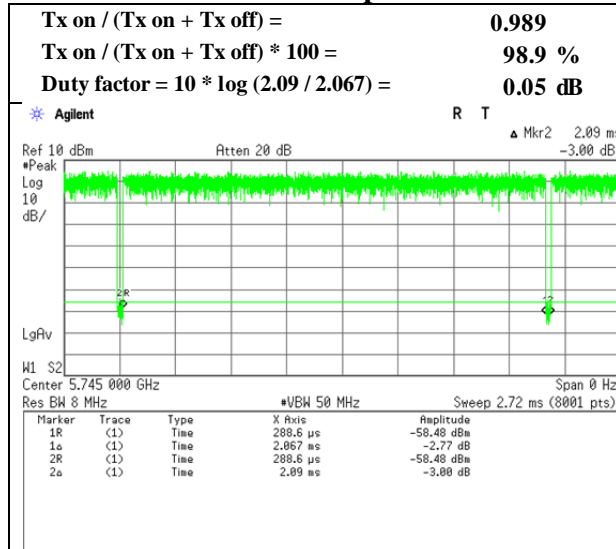

11ac-20 VHT0

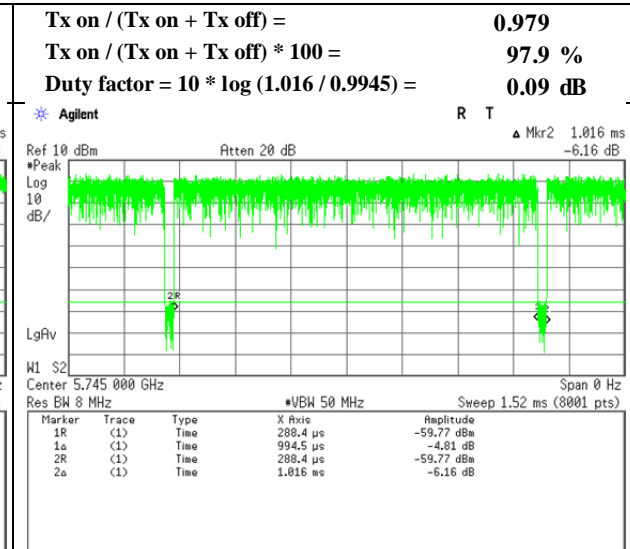

11ac-40 VHT0

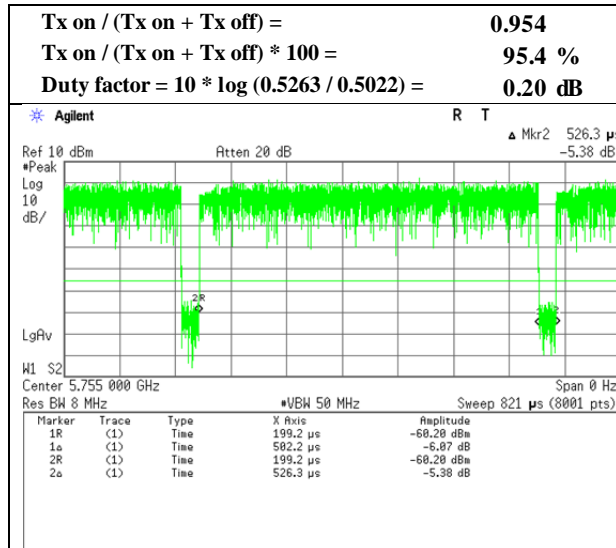

11ac-80 VHT0

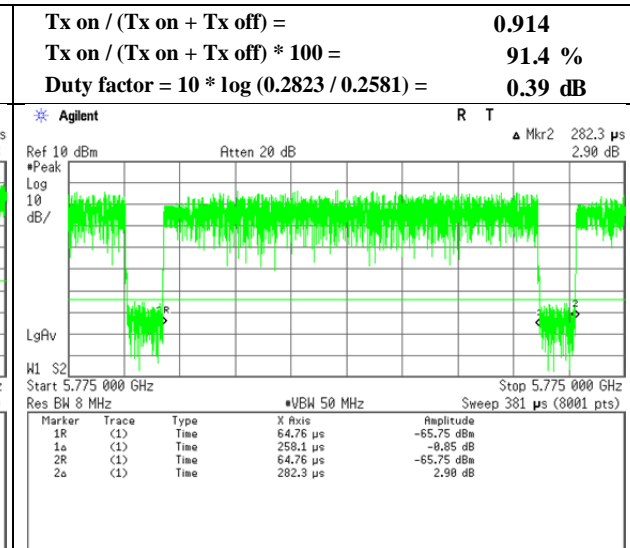

Maximum Power Spectral Density

Test place : Ise EMC Lab. No.7 Shielded Room
 Report No. : 11220705H
 Date : November 24, 2015
 Temperature / Humidity : 23deg. C / 45 % RH
 Engineer : Tsubasa Takayama
 Mode : Tx 11a

Antenna A

Applied limit: 15.407, mobile and portable client device

Tested Frequency [MHz]	PSD Reading [dBm /MHz]	Cable Loss [dB]	Atten. Loss [dB]	Duty Factor [dB]	Antenna Gain [dBi]	RBW Correction Factor [dB]	PSD (Conducted)			PSD (e.i.r.p.)		
							Result [dBm /MHz]	Limit [dBm /MHz]	Margin [dB]	Result [dBm /MHz]	Limit [dBm /MHz]	Margin [dB]
5745	-13.98	3.24	10.04	0.05	-0.35	0.27	-0.37	30.00	30.37	-0.72	36.00	36.72
5785	-14.57	3.25	10.04	0.05	-0.35	0.27	-0.96	30.00	30.96	-1.31	36.00	37.31
5825	-14.69	3.27	10.04	0.05	-0.35	0.27	-1.06	30.00	31.06	-1.41	36.00	37.41

Sample Calculation:

PSD: Power Spectral Density

The PSD within 5725 MHz to 5825 MHz are based on any 500 kHz band.

RBW Correction Factor = $10 * \log(\text{Specified bandwidth} / \text{Measured bandwidth})$

PSD Result (Conducted) = Reading + Cable Loss (including the cable(s) customer supplied) + Atten. Loss + Duty Factor + RBW Correction Factor

PSD Result (e.i.r.p.) = Conducted PSD Result + Antenna Gain

The conducted PSD limit was reduced by the amount in dB that the directional gain of the antenna exceeds 6 dBi. (All frequencies for FCC, 5725 MHz-5850 MHz for IC)

UL Japan, Inc.

Ise EMC Lab.

4383-326 Asama-cho, Ise-shi, Mie-ken 516-0021 JAPAN

Telephone : +81 596 24 8999

Facsimile : +81 596 24 8124

Maximum Power Spectral Density

Test place	Ise EMC Lab. No.7 Shielded Room
Report No.	11220705H
Date	November 24, 2015
Temperature / Humidity	23deg. C / 45 % RH
Engineer	Tsubasa Takayama
Mode	Tx 11a

Antenna B

Applied limit: 15.407, mobile and portable client device

Tested Frequency [MHz]	PSD Reading [dBm /MHz]	Cable Loss [dB]	Atten. Loss [dB]	Duty Factor [dB]	Antenna Gain [dBi]	RBW Correction Factor [dB]	PSD (Conducted)			PSD (e.i.r.p.)		
							Result [dBm /MHz]	Limit [dBm /MHz]	Margin [dB]	Result [dBm /MHz]	Limit [dBm /MHz]	Margin [dB]
5745	-14.06	3.24	10.04	0.05	-0.35	0.27	-0.45	30.00	30.45	-0.80	36.00	36.80
5785	-14.62	3.25	10.04	0.05	-0.35	0.27	-1.01	30.00	31.01	-1.36	36.00	37.36
5825	-14.55	3.27	10.04	0.05	-0.35	0.27	-0.92	30.00	30.92	-1.27	36.00	37.27

Sample Calculation:

PSD: Power Spectral Density

The PSD within 5725 MHz to 5825 MHz are based on any 500 kHz band.

RBW Correction Factor = $10 * \log(\text{Specified bandwidth} / \text{Measured bandwidth})$

PSD Result (Conducted) = Reading + Cable Loss (including the cable(s) customer supplied) + Atten. Loss + Duty Factor + RBW Correction Factor

PSD Result (e.i.r.p.) = Conducted PSD Result + Antenna Gain

The conducted PSD limit was reduced by the amount in dB that the directional gain of the antenna exceeds 6 dBi. (All frequencies for FCC, 5725 MHz-5850 MHz for IC)

UL Japan, Inc.

Ise EMC Lab.

4383-326 Asama-cho, Ise-shi, Mie-ken 516-0021 JAPAN

Telephone : +81 596 24 8999

Facsimile : +81 596 24 8124

Maximum Power Spectral Density

Test place : Ise EMC Lab. No.7 Shielded Room
 Report No. : 11220705H
 Date : November 24, 2015
 Temperature / Humidity : 23deg. C / 45 % RH
 Engineer : Tsubasa Takayama
 Mode : Tx 11ac-20

Applied limit: 15.407, mobile and portable client device

Tested Frequency [MHz]	PSD (Conducted)						PSD (e.i.r.p.)					
	Antenna			Result [dBm/MHz]	Limit [dBm/MHz]	Margin [dB]	Antenna			Result [dBm/MHz]	Limit [dBm/MHz]	Margin [dB]
	1 [mW/MHz]	2 [mW/MHz]	Sum [mW/MHz]				1 [mW/MHz]	2 [mW/MHz]	Sum [mW/MHz]			
5745	0.76	0.85	1.61	2.08	30.00	27.92	0.70	0.79	1.49	1.73	36.00	34.27
5785	0.76	0.79	1.55	1.90	30.00	28.10	0.70	0.73	1.43	1.55	36.00	34.45
5825	0.76	0.76	1.52	1.81	30.00	28.19	0.70	0.70	1.40	1.46	36.00	34.54

Tested Frequency [MHz]	Duty Factor [dB]	RBW Correction Factor [dB]	Antenna A					Antenna B						
			PSD Reading [dBm/MHz]	Cable Loss [dB]	Atten. Loss [dB]	Antenna Gain [dBi]	PSD Result Cond. [dBm/MHz]	PSD Result e.i.r.p. [dBm/MHz]	PSD Reading [dBm/MHz]	Cable Loss [dB]	Atten. Loss [dB]	Antenna Gain [dBi]	PSD Result Cond. [dBm/MHz]	PSD Result e.i.r.p. [dBm/MHz]
			5745	0.09	0.27	-14.84	3.24	10.04	-0.35	-1.19	-1.54	-14.33	3.24	10.04
5785	0.09	0.27	-14.88	3.25	10.04	-0.35	-1.22	-1.57	-14.66	3.25	10.04	-0.35	-1.00	-1.35
5825	0.09	0.27	-14.88	3.27	10.04	-0.35	-1.21	-1.56	-14.87	3.27	10.04	-0.35	-1.20	-1.55

Sample Calculation:

PSD: Power Spectral Density

The PSD within 5725 MHz to 5825 MHz are based on any 500 kHz band.

RBW Correction Factor = $10 \cdot \log(\text{Specified bandwidth} / \text{Measured bandwidth})$

PSD Result (Conducted) = Reading + Cable Loss (including the cable(s) customer supplied) + Atten. Loss + Duty Factor + RBW Correction Factor

PSD Result (e.i.r.p.) = Conducted PSD Result + Antenna Gain

The conducted PSD limit was reduced by the amount in dB that the directional gain of the antenna exceeds 6 dBi. (All frequencies for FCC, 5725 MHz-5850 MHz for IC)

Maximum Power Spectral Density

Test place : Ise EMC Lab. No.7 Shielded Room
 Report No. : 11220705H
 Date : November 24, 2015
 Temperature / Humidity : 23deg. C / 45 % RH
 Engineer : Tsubasa Takayama
 Mode : Tx 11ac-40

Applied limit: 15.407, mobile and portable client device

Tested Frequency [MHz]	PSD (Conducted)						PSD (e.i.r.p.)					
	Antenna			Result [dBm/MHz]	Limit [dBm/MHz]	Margin [dB]	Antenna			Result [dBm/MHz]	Limit [dBm/MHz]	Margin [dB]
	1 [mW/MHz]	2 [mW/MHz]	Sum [mW/MHz]				1 [mW/MHz]	2 [mW/MHz]	Sum [mW/MHz]			
5755	0.62	0.64	1.26	1.01	30.00	28.99	0.58	0.59	1.16	0.66	36.00	35.34
5795	0.52	0.54	1.05	0.23	30.00	29.77	0.48	0.50	0.97	-0.12	36.00	36.12

Tested Frequency [MHz]	Duty Factor [dB]	RBW Correction Factor [dB]	Antenna A					Antenna B						
			PSD Reading [dBm/MHz]	Cable Loss [dB]	Atten. Loss [dB]	Antenna Gain [dBi]	PSD Result Cond. [dBm/MHz]	PSD Result e.i.r.p. [dBm/MHz]	PSD Reading [dBm/MHz]	Cable Loss [dB]	Atten. Loss [dB]	Antenna Gain [dBi]	PSD Result Cond. [dBm/MHz]	PSD Result e.i.r.p. [dBm/MHz]
5755	0.20	0.27	-15.81	3.24	10.04	-0.35	-2.05	-2.40	-15.71	3.24	10.04	-0.35	-1.96	-2.31
5795	0.20	0.27	-16.64	3.26	10.04	-0.35	-2.87	-3.22	-16.46	3.25	10.04	-0.35	-2.70	-3.05

Sample Calculation:

PSD: Power Spectral Density

The PSD within 5725 MHz to 5825 MHz are based on any 500 kHz band.

RBW Correction Factor = $10 * \log(\text{Specified bandwidth} / \text{Measured bandwidth})$

PSD Result (Conducted) = Reading + Cable Loss (including the cable(s) customer supplied) + Atten. Loss + Duty Factor + RBW Correction Factor

PSD Result (e.i.r.p.) = Conducted PSD Result + Antenna Gain

The conducted PSD limit was reduced by the amount in dB that the directional gain of the antenna exceeds 6 dBi. (All frequencies for FCC, 5725 MHz-5850 MHz for IC)

Maximum Power Spectral Density

Test place : Ise EMC Lab. No.7 Shielded Room
 Report No. : 11220705H
 Date : November 24, 2015
 Temperature / Humidity : 23deg. C / 45 % RH
 Engineer : Tsubasa Takayama
 Mode : Tx 11ac-80

Applied limit: 15.407, mobile and portable client device

Tested Frequency [MHz]	PSD (Conducted)						PSD (e.i.r.p.)					
	Antenna			Result	Limit	Margin	Antenna			Result	Limit	Margin
	1	2	Sum				1	2	Sum			
5775	0.33	0.30	0.64	-1.97	30.00	31.97	0.31	0.28	0.59	-2.32	36.00	38.32

Tested Frequency [MHz]	Duty Factor [dB]	RBW Correction Factor [dB]	Antenna A					Antenna B						
			PSD Reading	Cable Loss	Atten. Loss	Antenna Gain	PSD Result Cond.	e.i.r.p.	PSD Reading	Cable Loss	Atten. Loss	Antenna Gain	PSD Result Cond.	e.i.r.p.
			[dBm/MHz]	[dB]	[dB]	[dBi]	[dBm/MHz]	[dBm/MHz]	[dBm/MHz]	[dB]	[dB]	[dBi]	[dBm/MHz]	[dBm/MHz]
5775	0.39	0.27	-18.75	3.25	10.04	-0.35	-4.80	-5.15	-19.11	3.25	10.04	-0.35	-5.16	-5.51

Sample Calculation:

PSD: Power Spectral Density

The PSD within 5725 MHz to 5825 MHz are based on any 500 kHz band.

RBW Correction Factor = $10 * \log(\text{Specified bandwidth} / \text{Measured bandwidth})$

PSD Result (Conducted) = Reading + Cable Loss (including the cable(s) customer supplied) + Atten. Loss + Duty Factor + RBW Correction Factor

PSD Result (e.i.r.p.) = Conducted PSD Result + Antenna Gain

The conducted PSD limit was reduced by the amount in dB that the directional gain of the antenna exceeds 6 dBi. (All frequencies for FCC, 5725 MHz-5850 MHz for IC)

Maximum Power Spectral Density

Test place	Ise EMC Lab. No.7 Shielded Room
Report No.	11220705H
Date	November 24, 2015
Temperature / Humidity	23deg. C / 45 % RH
Engineer	Tsubasa Takayama
Mode	Tx 11a

11a, Antenna A

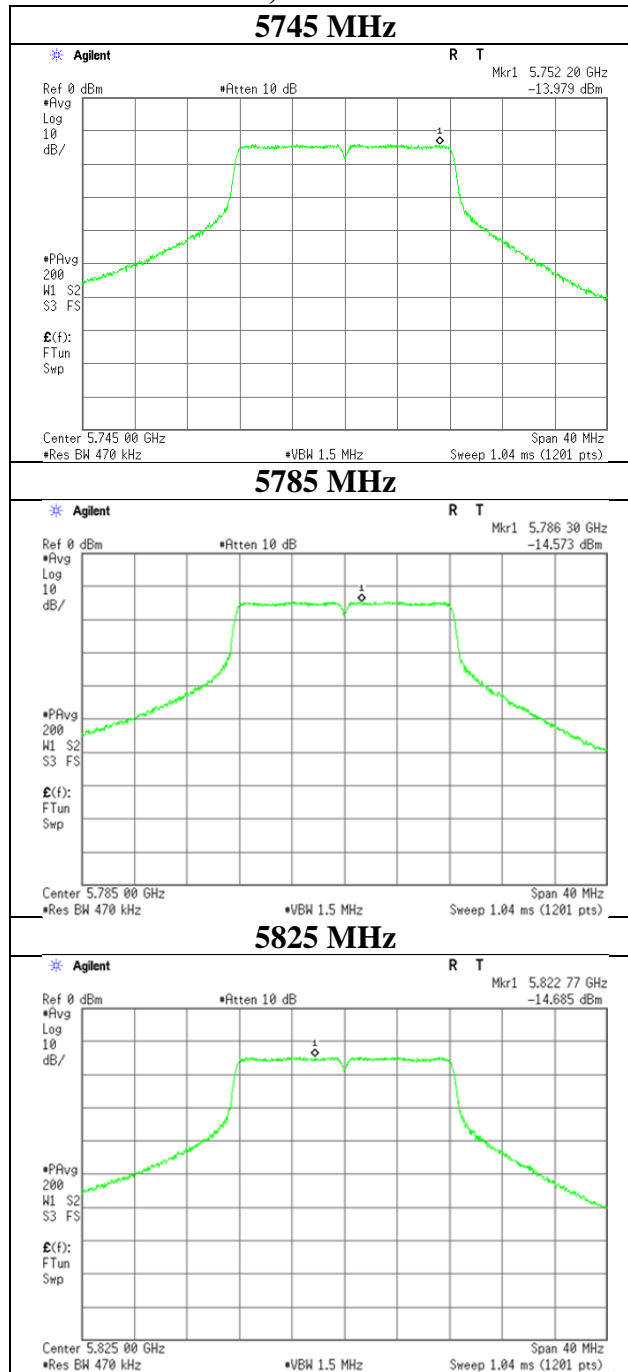

UL Japan, Inc.

Ise EMC Lab.

4383-326 Asama-cho, Ise-shi, Mie-ken 516-0021 JAPAN

Telephone : +81 596 24 8999

Facsimile : +81 596 24 8124

Maximum Power Spectral Density

Test place Ise EMC Lab. No.7 Shielded Room
Report No. 11220705H
Date November 24, 2015
Temperature / Humidity 23deg. C / 45 % RH
Engineer Tsubasa Takayama
Mode Tx 11a

11a, Antenna B

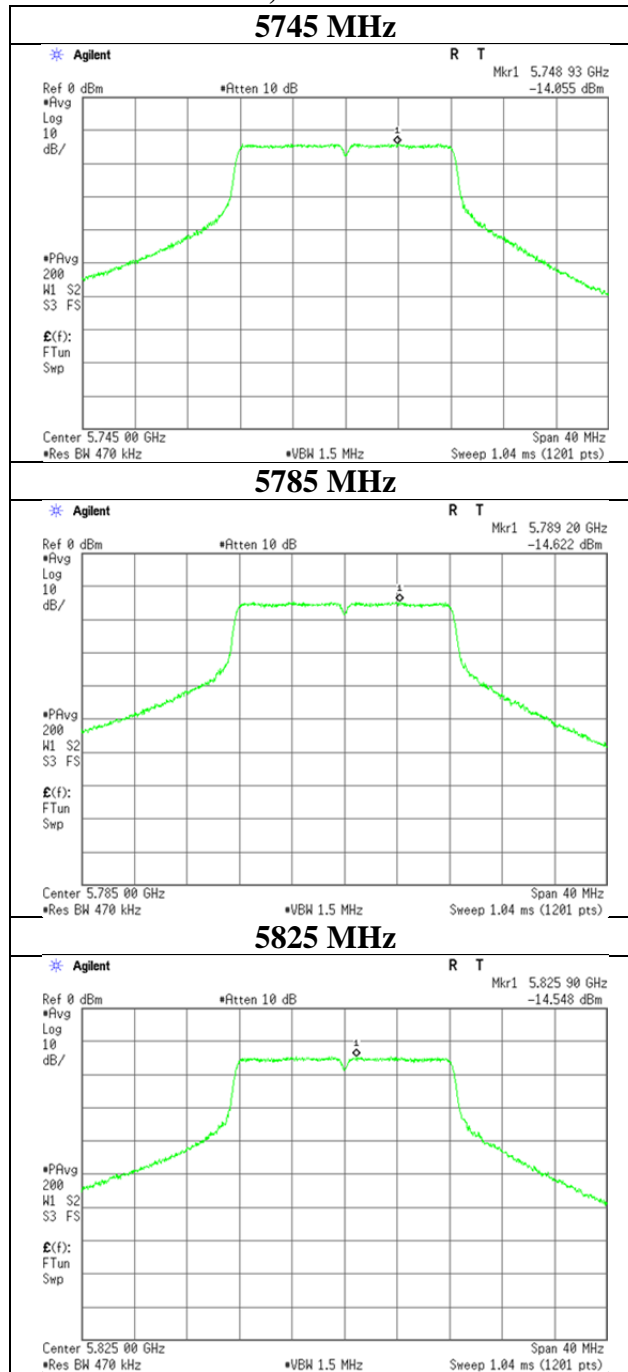

Maximum Power Spectral Density

Test place Ise EMC Lab. No.7 Shielded Room
Report No. 11220705H
Date November 24, 2015
Temperature / Humidity 23deg. C / 45 % RH
Engineer Tsubasa Takayama
Mode Tx 11ac-20

11ac-20, Antenna A

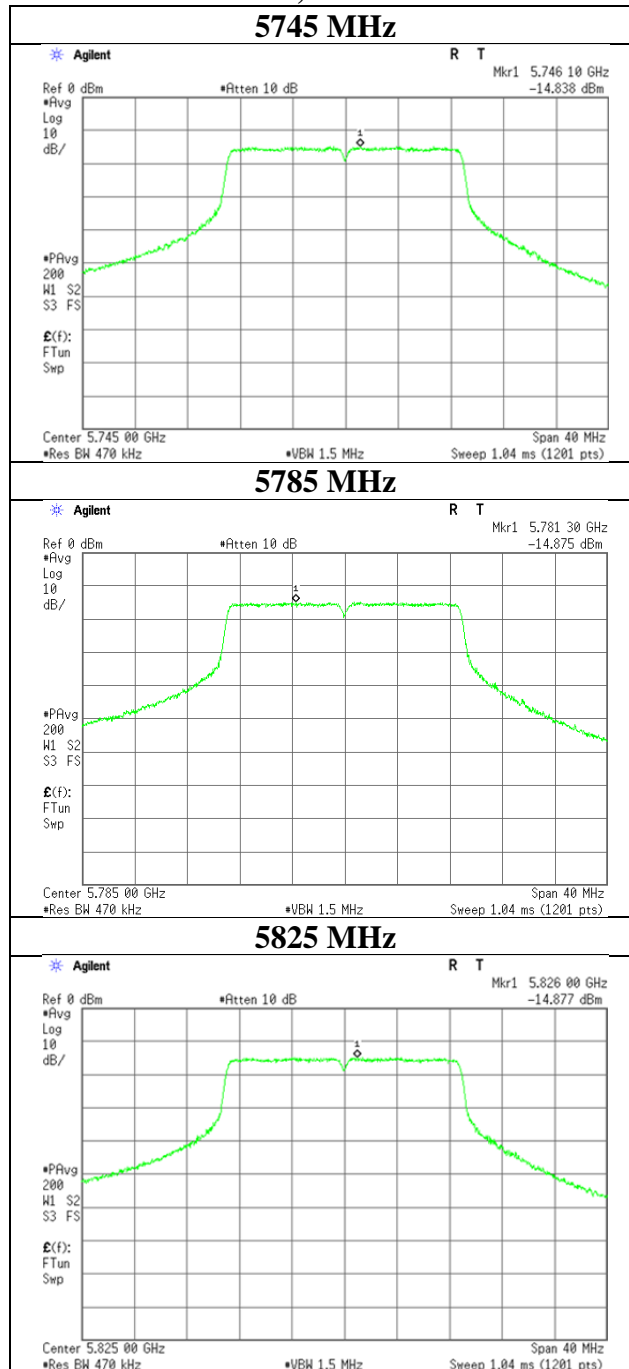

UL Japan, Inc.

Ise EMC Lab.

4383-326 Asama-cho, Ise-shi, Mie-ken 516-0021 JAPAN

Telephone : +81 596 24 8999

Facsimile : +81 596 24 8124

Maximum Power Spectral Density

Test place	Ise EMC Lab. No.7 Shielded Room
Report No.	11220705H
Date	November 24, 2015
Temperature / Humidity	23deg. C / 45 % RH
Engineer	Tsubasa Takayama
Mode	Tx 11ac-20

11ac-20, Antenna B

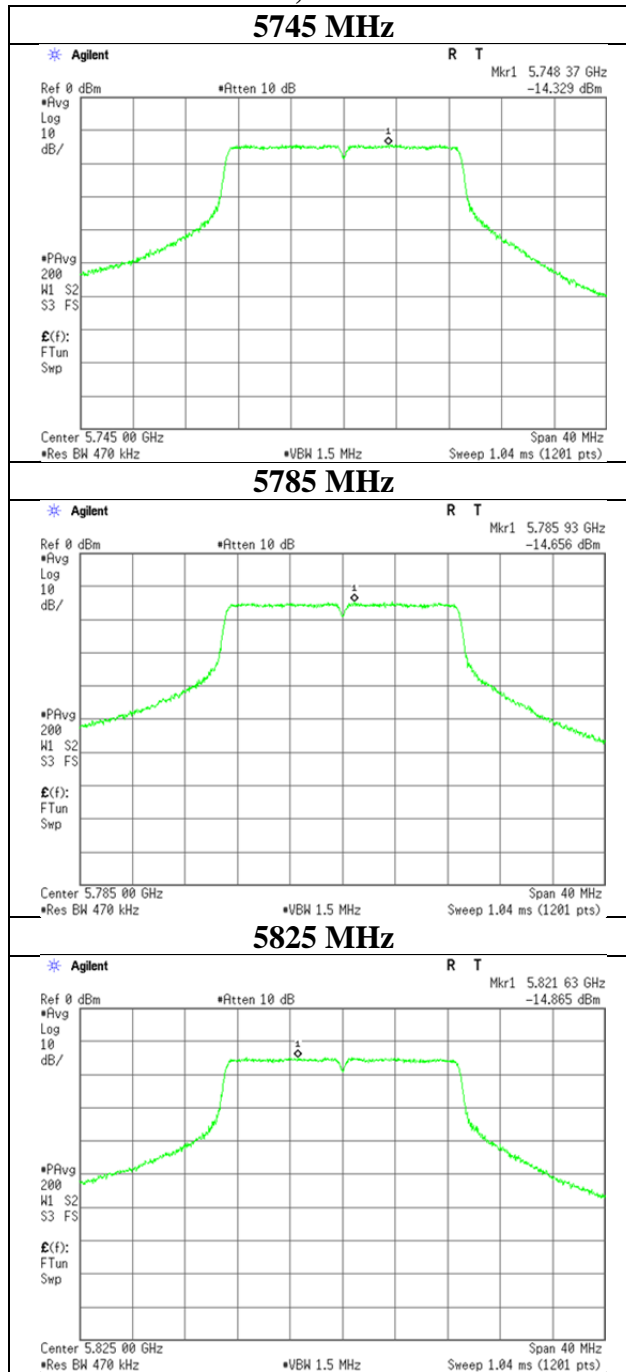

Maximum Power Spectral Density

Test place : Ise EMC Lab. No.7 Shielded Room
Report No. : 11220705H
Date : November 24, 2015
Temperature / Humidity : 23deg. C / 45 % RH
Engineer : Tsubasa Takayama
Mode : Tx 11ac-40

11ac-40, Antenna A

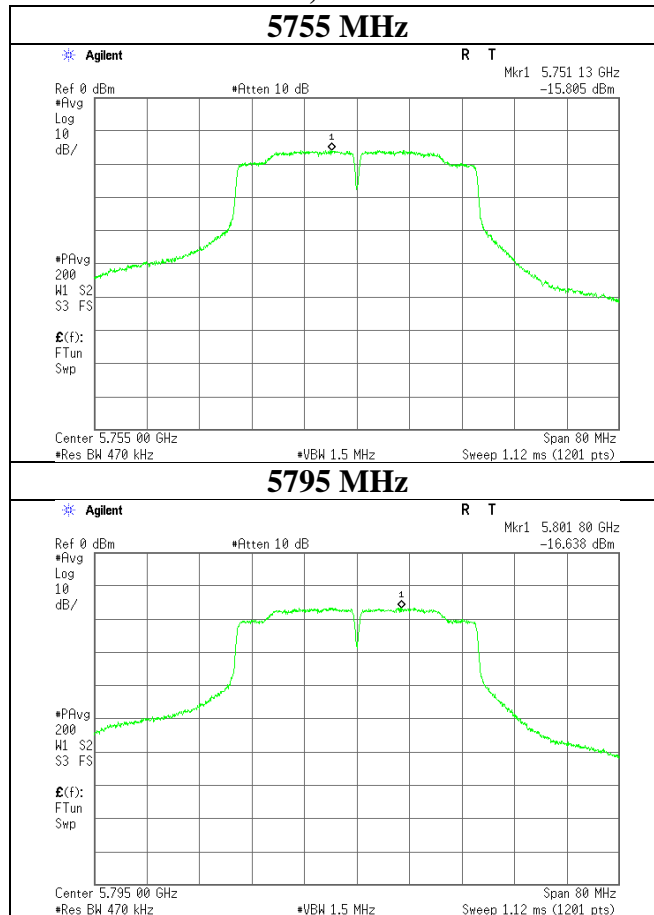

Maximum Power Spectral Density

Test place : Ise EMC Lab. No.7 Shielded Room
Report No. : 11220705H
Date : November 24, 2015
Temperature / Humidity : 23deg. C / 45 % RH
Engineer : Tsubasa Takayama
Mode : Tx 11ac-40

11ac-40, Antenna B

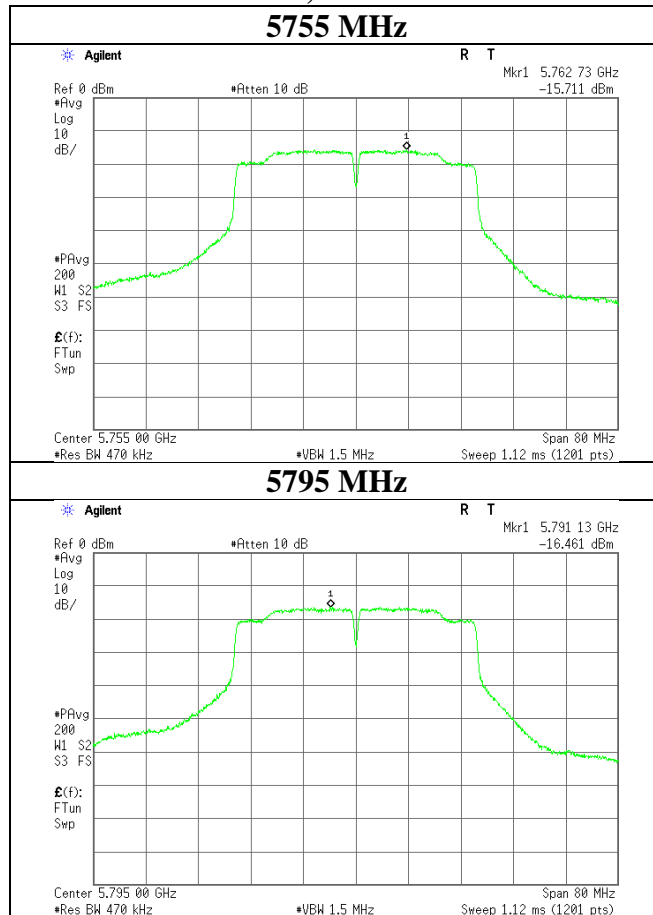

UL Japan, Inc.

Ise EMC Lab.

4383-326 Asama-cho, Ise-shi, Mie-ken 516-0021 JAPAN

Telephone : +81 596 24 8999

Facsimile : +81 596 24 8124

Maximum Power Spectral Density

Test place : Ise EMC Lab. No.7 Shielded Room
Report No. : 11220705H
Date : November 24, 2015
Temperature / Humidity : 23deg. C / 45 % RH
Engineer : Tsubasa Takayama
Mode : Tx 11ac-80

11ac-80, Antenna A

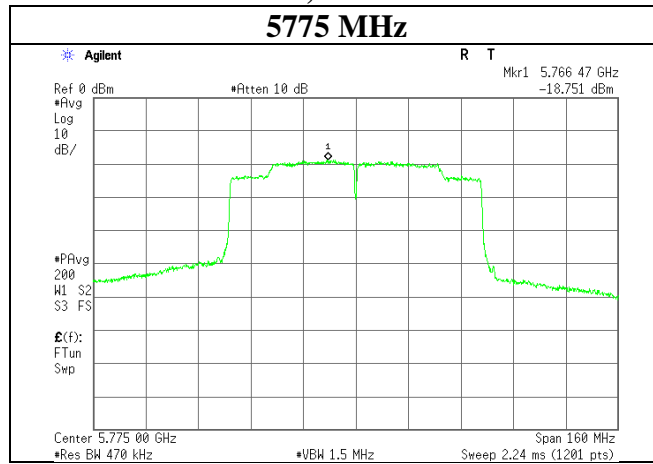

Maximum Power Spectral Density

Test place : Ise EMC Lab. No.7 Shielded Room
Report No. : 11220705H
Date : November 24, 2015
Temperature / Humidity : 23deg. C / 45 % RH
Engineer : Tsubasa Takayama
Mode : Tx 11ac-80

11ac-80, Antenna B

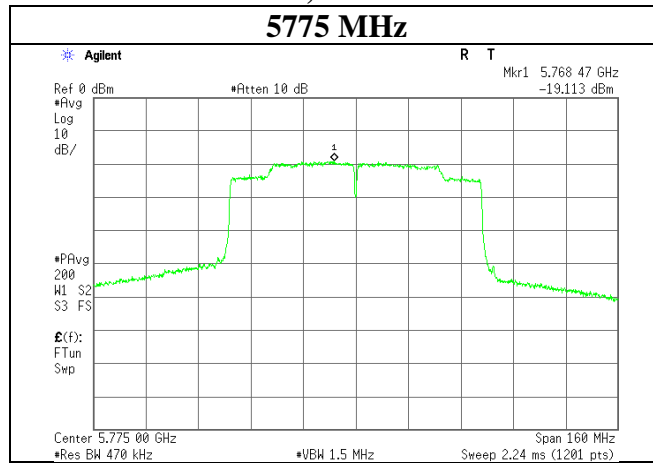

Radiated Spurious Emission

Test place Ise EMC Lab. No.2 and No.4 Semi Anechoic Chamber
Report No. 11220705H
Date November 25, 2015 November 25, 2015 December 17, 2015
Temperature / Humidity 20deg. C / 38 % RH 22deg. C / 45 % RH 25 deg. C / 31 % RH
Engineer Takafumi Noguchi Koji Yamamoto Takafumi Noguchi
(1-10GHz) (10-18GHz) (18-40GHz)
Mode Tx 11ac-20 5745 MHz

Polarity	Frequency [MHz]	Detector	Reading [dBuV]	Ant.Fac. [dB/m]	Loss [dB]	Gain [dB]	Duty Factor [dB]	Result [dBuV/m]	Limit [dBuV/m]	Margin [dB]	Remark
Hori	5715.000	PK	61.3	33.2	4.0	33.9	-	64.6	68.2	3.6	
Hori	5725.000	PK	73.4	33.2	4.0	33.9	-	76.7	78.2	1.5	
Hori	11490.000	PK	43.7	41.1	-1.7	33.7	-	49.4	73.9	24.5	Floor Noise
Hori	17235.000	PK	43.8	42.8	-0.6	32.7	-	53.3	73.9	20.6	Floor Noise
Hori	22980.000	PK	47.0	38.4	-0.6	33.5	-	51.3	73.9	22.6	
Hori	11490.000	AV	34.7	41.1	-1.7	33.7	-	40.4	53.9	13.5	Floor Noise
Hori	17235.000	AV	35.3	42.8	-0.6	32.7	-	44.8	53.9	9.1	Floor Noise
Hori	22980.000	AV	39.3	38.4	-0.6	33.5	0.1	43.7	53.9	10.2	
Vert	5715.000	PK	60.3	33.2	4.0	33.9	-	63.6	68.2	4.6	
Vert	5725.000	PK	72.9	33.2	4.0	33.9	-	76.2	78.2	2.0	
Vert	11490.000	PK	43.3	41.1	-1.7	33.7	-	49.0	73.9	24.9	Floor Noise
Vert	17235.000	PK	44.6	42.8	-0.6	32.7	-	54.1	73.9	19.8	Floor Noise
Vert	22980.000	PK	50.0	38.4	-0.6	33.5	-	54.3	73.9	19.6	
Vert	11490.000	AV	34.3	41.1	-1.7	33.7	-	40.0	53.9	13.9	Floor Noise
Vert	17235.000	AV	35.7	42.8	-0.6	32.7	-	45.2	53.9	8.7	Floor Noise
Vert	22980.000	AV	44.8	38.4	-0.6	33.5	0.1	49.2	53.9	4.7	

Result = Reading + Ant Factor + Loss (Cable+Attenuator+Filter-Distance factor(above 10GHz)) - Gain(Amplifier) + Duty factor

*Other frequency noises omitted in this report were not seen or had enough margin (more than 20dB).

Distance factor: 10GHz-26.5GHz 20log(3.0m/1.0m)= 9.5dB
 26.5GHz-40GHz 20log(3.0m/0.5m)=15.6dB

Radiated Spurious Emission

Test place	Ise EMC Lab. No.2 Semi Anechoic Chamber
Report No.	11220705H
Date	November 25, 2015
Temperature / Humidity	20deg. C / 38 % RH
Engineer	Takafumi Noguchi
Mode	Tx 11ac-20 5745 MHz

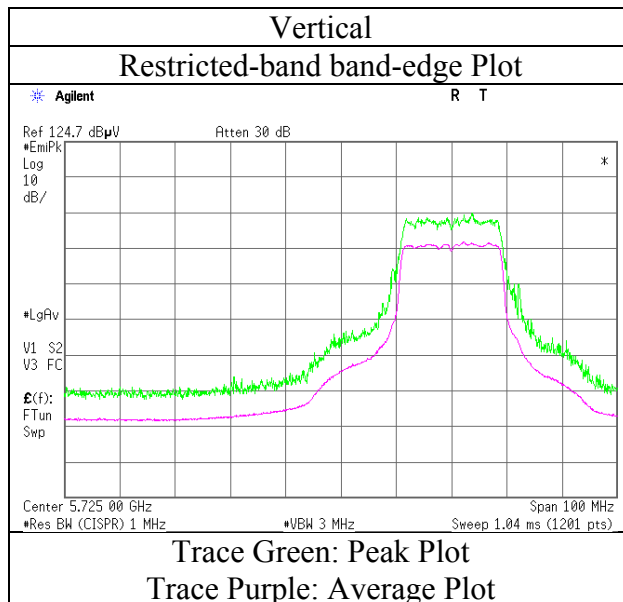
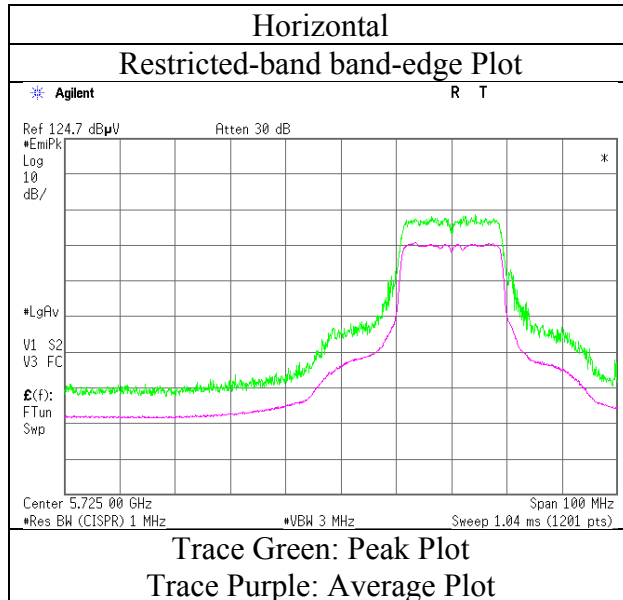

* Final result of restricted band edge was shown in tabular data.

Radiated Spurious Emission

Test place Ise EMC Lab. No.2 and No.4 Semi Anechoic Chamber
 Report No. 11220705H
 Date November 25, 2015 November 25, 2015 December 17, 2015
 Temperature / Humidity 20deg. C / 38 % RH 22deg. C / 45 % RH 25 deg. C / 31 % RH
 Engineer Takafumi Noguchi Koji Yamamoto Takafumi Noguchi
 (1-10GHz) (10-18GHz) (18-40GHz)
 Mode Tx 11ac-20 5785 MHz

Polarity	Frequency [MHz]	Detector	Reading [dBuV]	Ant.Fac. [dB/m]	Loss [dB]	Gain [dB]	Duty Factor [dB]	Result [dBuV/m]	Limit [dBuV/m]	Margin [dB]	Remark
Hori	11570.000	PK	43.9	41.0	-1.7	33.7	-	49.5	73.9	24.4	Floor Noise
Hori	17355.000	PK	44.2	43.4	-0.4	32.7	-	54.5	73.9	19.4	Floor Noise
Hori	23140.000	PK	49.6	38.5	-0.5	33.4	-	54.2	73.9	19.7	
Hori	11570.000	AV	34.5	41.0	-1.7	33.7	-	40.1	53.9	13.8	Floor Noise
Hori	17355.000	AV	35.5	43.4	-0.4	32.7	-	45.8	53.9	8.1	Floor Noise
Hori	23140.000	AV	44.1	38.5	-0.5	33.4	0.1	48.8	53.9	5.1	
Vert	11570.000	PK	43.6	41.0	-1.7	33.7	-	49.2	73.9	24.7	Floor Noise
Vert	17355.000	PK	44.1	43.4	-0.4	32.7	-	54.4	73.9	19.5	Floor Noise
Vert	23140.000	PK	50.3	38.5	-0.5	33.4	-	54.9	73.9	19.0	
Vert	11570.000	AV	34.7	41.0	-1.7	33.7	-	40.3	53.9	13.6	Floor Noise
Vert	17355.000	AV	35.3	43.4	-0.4	32.7	-	45.6	53.9	8.3	Floor Noise
Vert	23140.000	AV	44.5	38.5	-0.5	33.4	0.1	49.2	53.9	4.7	

Result = Reading + Ant Factor + Loss (Cable+Attenuator+Filter-Distance factor(above 10GHz)) - Gain(Amplifier) + Duty factor

*Other frequency noises omitted in this report were not seen or had enough margin (more than 20dB).

Distance factor: 10GHz-26.5GHz 20log(3.0m/1.0m)= 9.5dB
 26.5GHz-40GHz 20log(3.0m/0.5m)=15.6dB

Radiated Spurious Emission

Test place	Ise EMC Lab. No.2 Semi Anechoic Chamber
Report No.	11220705H
Date	November 25, 2015
Temperature / Humidity	20deg. C / 38 % RH
Engineer	Takafumi Noguchi
Mode	Tx 11ac-20 5825 MHz

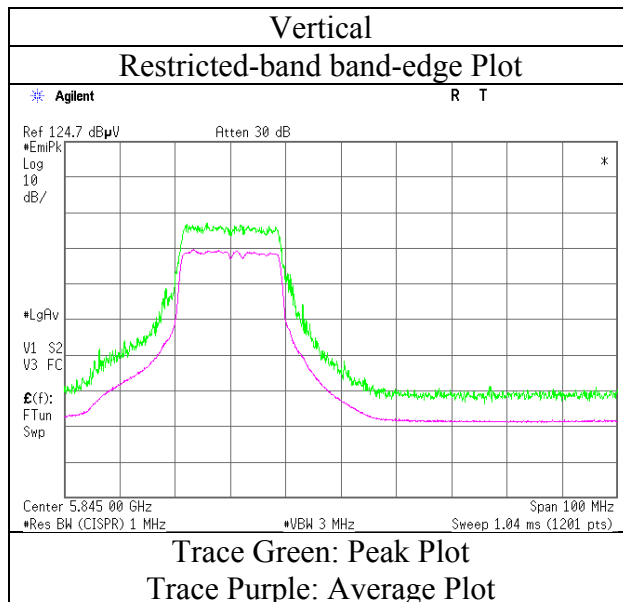
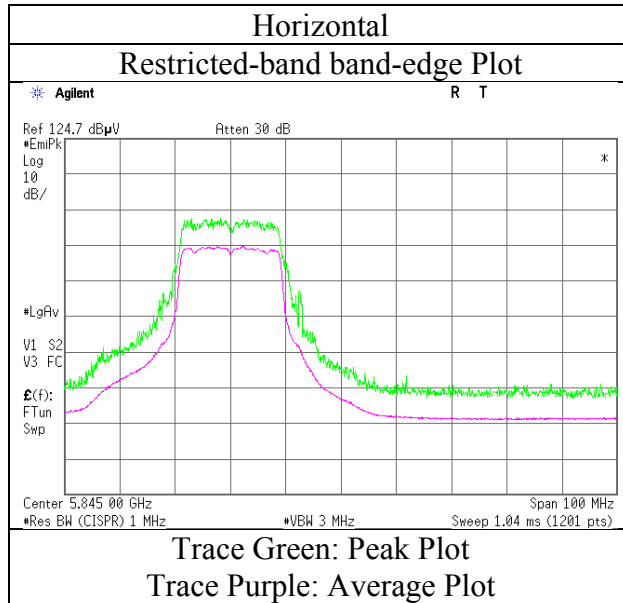

* Final result of restricted band edge was shown in tabular data.

Radiated Spurious Emission

Test place Ise EMC Lab. No.2 and No.4 Semi Anechoic Chamber
Report No. 11220705H
Date November 25, 2015 December 17, 2015
Temperature / Humidity 22deg. C / 45 % RH 25 deg. C / 31 % RH
Engineer Koji Yamamoto Takafumi Noguchi
(1-18GHz) (18-40GHz)
Mode Tx 11ac-40 5755 MHz

Polarity	Frequency [MHz]	Detector	Reading [dBuV]	Ant.Fac. [dB/m]	Loss [dB]	Gain [dB]	Duty Factor [dB]	Result [dBuV/m]	Limit [dBuV/m]	Margin [dB]	Remark
Hori	5715.000	PK	61.1	33.2	4.0	33.9	-	64.4	68.2	3.8	
Hori	5725.000	PK	67.2	33.2	4.0	33.9	-	70.5	78.2	7.7	
Hori	11510.000	PK	44.6	41.1	-1.7	33.7	-	50.3	73.9	23.6	Floor Noise
Hori	17265.000	PK	44.7	43.0	-0.6	32.7	-	54.4	73.9	19.5	Floor Noise
Hori	22840.000	PK	47.6	38.4	-0.6	33.5	-	51.9	73.9	22.0	
Hori	11510.000	AV	34.8	41.1	-1.7	33.7	-	40.5	53.9	13.4	Floor Noise
Hori	17265.000	AV	36.0	43.0	-0.6	32.7	-	45.7	53.9	8.2	Floor Noise
Hori	22840.000	AV	39.5	38.4	-0.6	33.5	0.2	44.0	53.9	9.9	
Vert	5715.000	PK	63.1	33.2	4.0	33.9	-	66.4	68.2	1.8	
Vert	5725.000	PK	70.7	33.2	4.0	33.9	-	74.0	78.2	4.2	
Vert	11510.000	PK	44.5	41.1	-1.7	33.7	-	50.2	73.9	23.7	Floor Noise
Vert	17265.000	PK	44.2	43.0	-0.6	32.7	-	53.9	73.9	20.0	Floor Noise
Vert	22840.000	PK	50.2	38.4	-0.6	33.5	-	54.5	73.9	19.4	
Vert	11510.000	AV	35.1	41.1	-1.7	33.7	-	40.8	53.9	13.1	Floor Noise
Vert	17265.000	AV	35.9	43.0	-0.6	32.7	-	45.6	53.9	8.3	Floor Noise
Vert	22840.000	AV	44.3	38.4	-0.6	33.5	0.2	48.8	53.9	5.1	

Result = Reading + Ant Factor + Loss (Cable+Attenuator+Filter-Distance factor(above 10GHz)) - Gain(Amplifier) + Duty factor

*Other frequency noises omitted in this report were not seen or had enough margin (more than 20dB).

Distance factor: 10GHz-26.5GHz 20log(3.0m/1.0m)= 9.5dB
26.5GHz-40GHz 20log(3.0m/0.5m)=15.6dB

Radiated Spurious Emission

Test place	Ise EMC Lab. No.2 Semi Anechoic Chamber
Report No.	11220705H
Date	November 25, 2015
Temperature / Humidity	22deg. C / 45 % RH
Engineer	Koji Yamamoto
Mode	Tx 11ac-40 5755 MHz

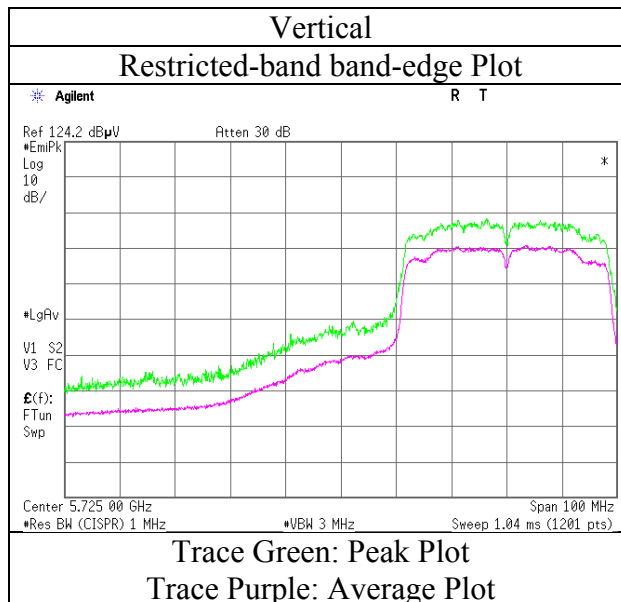
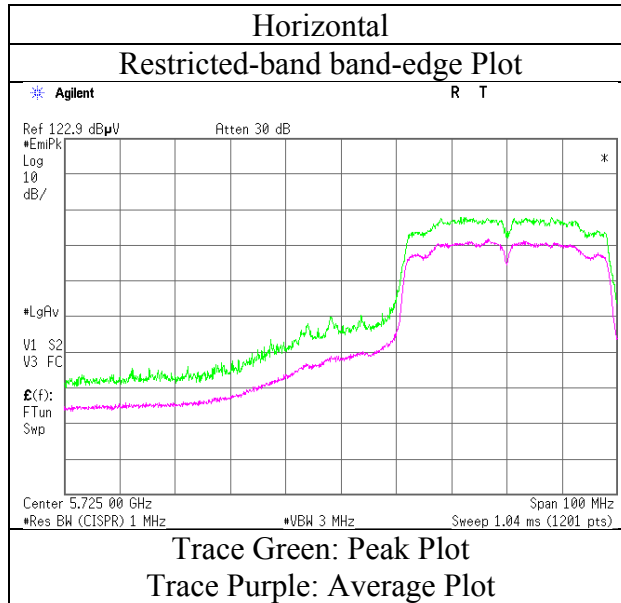

* Final result of restricted band edge was shown in tabular data.

Radiated Spurious Emission

Test place : Ise EMC Lab. No.2 and No.4 Semi Anechoic Chamber
Report No. : 11220705H
Date : November 25, 2015 December 17, 2015
Temperature / Humidity : 22deg. C / 45 % RH 25 deg. C / 31 % RH
Engineer : Koji Yamamoto Takafumi Noguchi
 (1-18GHz) (18-40GHz)
Mode : Tx 11ac-40 5795 MHz

Polarity	Frequency [MHz]	Detector	Reading [dBuV]	Ant.Fac. [dB/m]	Loss [dB]	Gain [dB]	Duty Factor [dB]	Result [dBuV/m]	Limit [dBuV/m]	Margin [dB]	Remark
Hori	5850.000	PK	48.2	33.4	4.0	34.0	-	51.6	78.2	26.6	
Hori	5860.000	PK	48.1	33.4	4.0	34.0	-	51.5	68.2	16.7	
Hori	11590.000	PK	43.9	41.0	-1.6	33.7	-	49.6	73.9	24.3	Floor Noise
Hori	17385.000	PK	44.2	43.5	-0.4	32.7	-	54.6	73.9	19.3	Floor Noise
Hori	23180.000	PK	49.4	38.6	-0.5	33.4	-	54.1	73.9	19.8	
Hori	11590.000	AV	35.1	41.0	-1.6	33.7	-	40.8	53.9	13.1	Floor Noise
Hori	17385.000	AV	35.9	43.5	-0.4	32.7	-	46.3	53.9	7.6	Floor Noise
Hori	23180.000	AV	43.7	38.6	-0.5	33.4	0.2	48.6	53.9	5.3	
Vert	5850.000	PK	49.7	33.4	4.0	34.0	-	53.1	78.2	25.1	
Vert	5860.000	PK	48.7	33.4	4.0	34.0	-	52.1	68.2	16.1	
Vert	11590.000	PK	44.3	41.0	-1.6	33.7	-	50.0	73.9	23.9	Floor Noise
Vert	17385.000	PK	44.6	43.5	-0.4	32.7	-	55.0	73.9	18.9	Floor Noise
Vert	23180.000	PK	50.2	38.6	-0.5	33.4	-	54.9	73.9	19.0	
Vert	11590.000	AV	35.8	41.0	-1.6	33.7	-	41.5	53.9	12.4	Floor Noise
Vert	17385.000	AV	36.3	43.5	-0.4	32.7	-	46.7	53.9	7.2	Floor Noise
Vert	23180.000	AV	44.1	38.6	-0.5	33.4	0.2	49.0	53.9	4.9	

Result = Reading + Ant Factor + Loss (Cable+Attenuator+Filter-Distance factor(above 10GHz)) - Gain(Amplifier) + Duty factor

*Other frequency noises omitted in this report were not seen or had enough margin (more than 20dB).

Distance factor: 10GHz-26.5GHz 20log(3.0m/1.0m)= 9.5dB
 26.5GHz-40GHz 20log(3.0m/0.5m)=15.6dB

Radiated Spurious Emission

Test place	Ise EMC Lab. No.2 Semi Anechoic Chamber
Report No.	11220705H
Date	November 25, 2015
Temperature / Humidity	22deg. C / 45 % RH
Engineer	Koji Yamamoto
Mode	Tx 11ac-40 5795 MHz

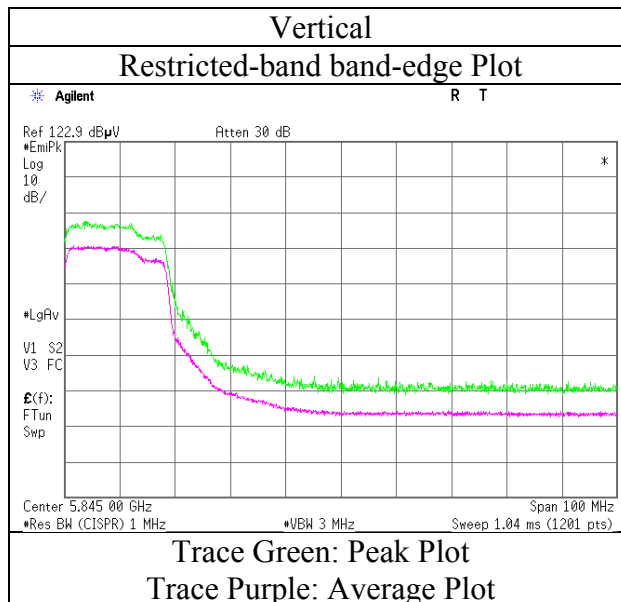
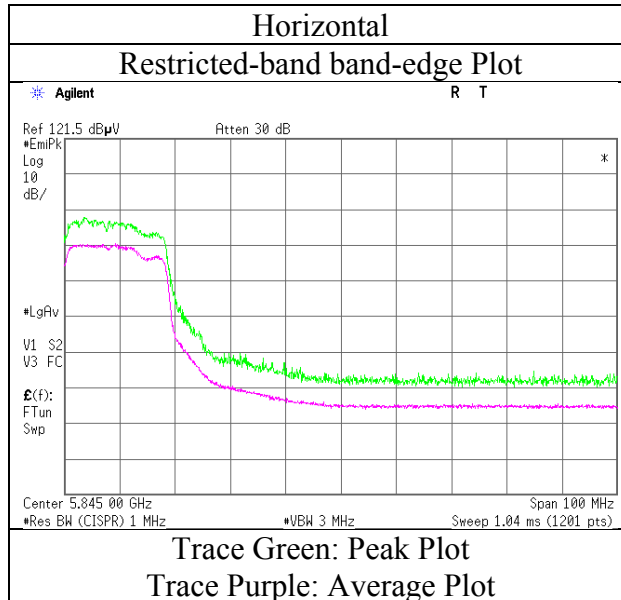

* Final result of restricted band edge was shown in tabular data.

Radiated Spurious Emission

Test place : Ise EMC Lab. No.2 and No.4 Semi Anechoic Chamber
Report No. : 11220705H
Date : November 25, 2015 December 17, 2015 December 18, 2015
Temperature / Humidity : 22deg. C / 45 % RH 25 deg. C / 31 % RH 20 deg. C / 31 % RH
Engineer : Koji Yamamoto Takafumi Noguchi Takafumi Noguchi
(1-18GHz) (18-40GHz) (30M-1GHz)
Mode : Tx 11ac-80 5775 MHz

Polarity	Frequency [MHz]	Detector	Reading [dBuV]	Ant.Fac. [dB/m]	Loss [dB]	Gain [dB]	Duty Factor [dB]	Result [dBuV/m]	Limit [dBuV/m]	Margin [dB]	Remark
Hori	42.208	QP	27.4	13.5	7.3	32.1	-	16.1	40.0	23.9	
Hori	48.235	QP	31.1	11.2	7.4	32.1	-	17.6	40.0	22.4	
Hori	87.439	QP	40.0	7.9	8.0	32.1	-	23.8	40.0	16.2	
Hori	99.488	QP	37.2	9.9	8.1	32.1	-	23.1	43.5	20.4	
Hori	119.696	QP	38.5	12.8	8.3	32.0	-	27.6	43.5	15.9	
Hori	331.530	QP	40.7	17.9	10.1	31.8	-	36.9	46.0	9.1	
Hori	5715.000	PK	63.2	33.2	4.0	33.9	-	66.5	68.2	1.7	
Hori	5725.000	PK	67.5	33.2	4.0	33.9	-	70.8	78.2	7.4	
Hori	5850.000	PK	61.6	33.4	4.0	34.0	-	65.0	78.2	13.2	
Hori	5860.000	PK	58.3	33.4	4.0	34.0	-	61.7	68.2	6.5	
Hori	11550.000	PK	45.2	41.0	-1.7	33.7	-	50.8	73.9	23.1	Floor Noise
Hori	17325.000	PK	44.3	43.2	-0.6	32.7	-	54.2	73.9	19.7	Floor Noise
Hori	23100.000	PK	47.8	38.5	-0.5	33.5	-	52.3	73.9	21.6	
Hori	11550.000	AV	36.1	41.0	-1.7	33.7	-	41.7	53.9	12.2	Floor Noise
Hori	17325.000	AV	36.5	43.2	-0.6	32.7	-	46.4	53.9	7.5	Floor Noise
Hori	23100.000	AV	39.4	38.5	-0.5	33.5	0.4	44.3	53.9	9.6	
Vert	42.208	QP	42.5	13.5	7.3	32.1	-	31.2	40.0	8.8	
Vert	45.224	QP	42.6	12.3	7.4	32.1	-	30.2	40.0	9.8	
Vert	80.360	QP	43.0	6.6	7.9	32.0	-	25.5	40.0	14.5	
Vert	99.488	QP	41.7	9.9	8.1	32.1	-	27.6	43.5	15.9	
Vert	119.696	QP	36.0	12.8	8.3	32.0	-	25.1	43.5	18.4	
Vert	331.530	QP	29.5	17.9	10.1	31.8	-	25.7	46.0	20.3	
Vert	5715.000	PK	62.8	33.2	4.0	33.9	-	66.1	68.2	2.1	
Vert	5725.000	PK	66.8	33.2	4.0	33.9	-	70.1	78.2	8.1	
Vert	5850.000	PK	60.0	33.4	4.0	34.0	-	63.4	78.2	14.8	
Vert	5860.000	PK	57.8	33.4	4.0	34.0	-	61.2	68.2	7.0	
Vert	11550.000	PK	44.5	41.0	-1.7	33.7	-	50.1	73.9	23.8	Floor Noise
Vert	17325.000	PK	44.1	43.2	-0.6	32.7	-	54.0	73.9	19.9	Floor Noise
Vert	23100.000	PK	50.2	38.5	-0.5	33.5	-	54.7	73.9	19.2	
Vert	11550.000	AV	35.1	41.0	-1.7	33.7	-	40.7	53.9	13.2	Floor Noise
Vert	17325.000	AV	36.3	43.2	-0.6	32.7	-	46.2	53.9	7.7	Floor Noise
Vert	23100.000	AV	44.8	38.5	-0.5	33.5	0.4	49.7	53.9	4.2	

Result = Reading + Ant Factor + Loss (Cable+Attenuator+Filter-Distance factor(above 10GHz)) - Gain(Amplifier) + Duty factor

*Other frequency noises omitted in this report were not seen or had enough margin (more than 20dB).

Distance factor: 10GHz-26.5GHz 20log(3.0m/1.0m)= 9.5dB
 26.5GHz-40GHz 20log(3.0m/0.5m)=15.6dB

Radiated Spurious Emission

Test place	Ise EMC Lab. No.2 Semi Anechoic Chamber
Report No.	11220705H
Date	November 25, 2015
Temperature / Humidity	22deg. C / 45 % RH
Engineer	Koji Yamamoto
Mode	Tx 11ac-80 5775 MHz

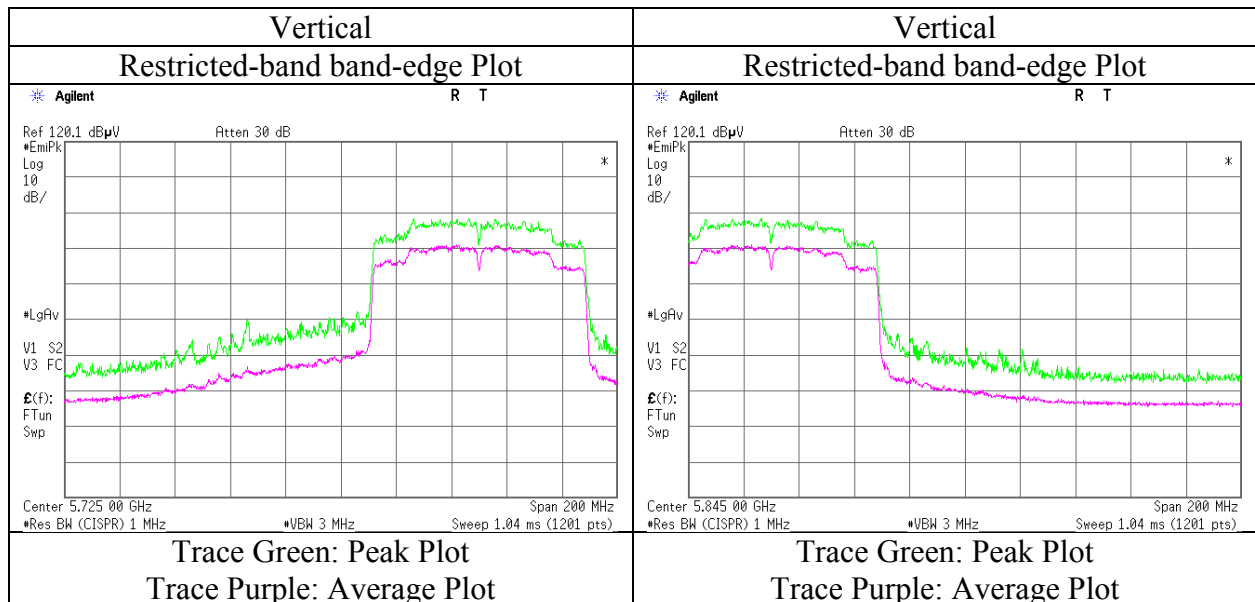
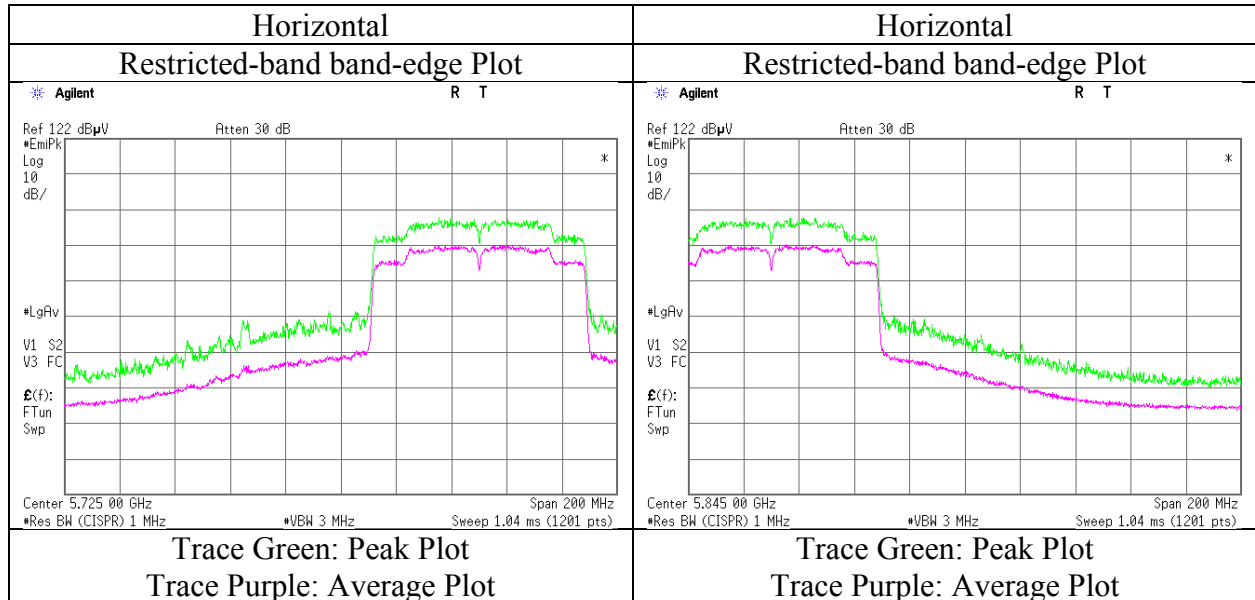

* Final result of restricted band edge was shown in tabular data.

Radiated Spurious Emission (Plot data, Worst case)

Test place	Ise EMC Lab. No.2 and No.4 Semi Anechoic Chamber		
Report No.	11220705H		
Date	November 25, 2015	December 17, 2015	December 18, 2015
Temperature / Humidity	22deg. C / 45 % RH	25 deg. C / 31 % RH	20 deg. C / 31 % RH
Engineer	Koji Yamamoto (1-18GHz)	Takafumi Noguchi (18-40GHz)	Takafumi Noguchi (30M-1GHz)
Mode	Tx 11ac-80 5775 MHz		

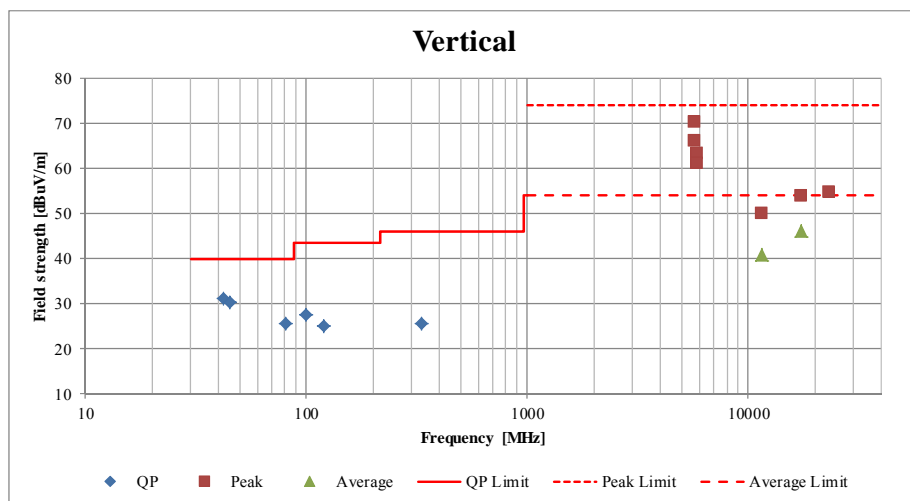
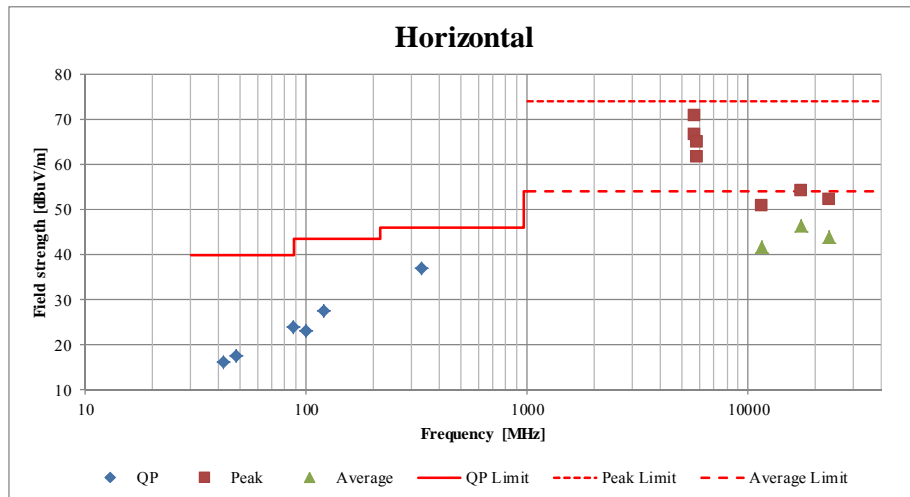

*These plots data contains sufficient number to show the trend of characteristic features for EUT.

Conducted Spurious Emission

Test place	Ise EMC Lab. No.7 Shielded Room
Report No.	11220705H
Date	November 24, 2015
Temperature / Humidity	23deg. C / 45 % RH
Engineer	Tsubasa Takayama
Mode	Tx 11a

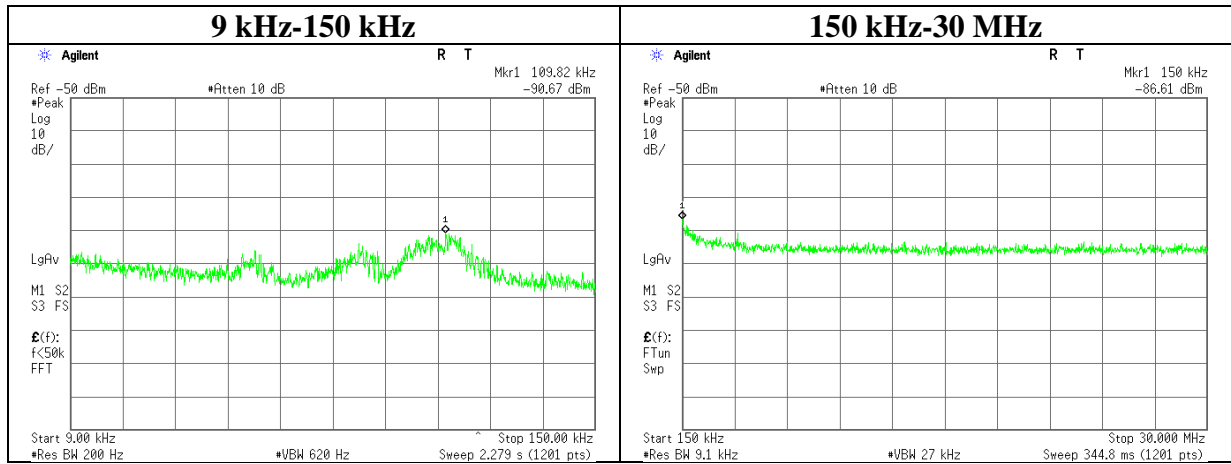

Frequency	Reading	Cable Loss	Attenuator	Antenna Gain	N	EIRP	Distance	Ground bounce	E	Limit	Margin	Remark
[kHz]	[dBm]	[dB]	[dB]	[dBi]	(Number of Output)	[dBm]	[m]	[dB]	(field strength) [dBuV/m]	[dBuV/m]	[dB]	
109.82	-90.7	0.00	9.8	6.0	2	-71.8	300	6.0	-10.6	26.7	37.3	
150.00	-86.6	0.00	9.8	6.0	2	-67.8	300	6.0	-6.5	24.0	30.5	

$E = \text{EIRP} - 20 \cdot \log(D) + \text{Ground bounce} + 104.8 \text{ [dBuV/m]}$

$\text{EIRP} = \text{Reading} + \text{Cable Loss} + \text{Attenuator} + \text{Antenna Gain} + 10 \cdot \log(N)$

UL Japan, Inc.

Ise EMC Lab.

4383-326 Asama-cho, Ise-shi, Mie-ken 516-0021 JAPAN

Telephone : +81 596 24 8999

Facsimile : +81 596 24 8124

Conducted Spurious Emission

Test place	Ise EMC Lab. No.7 Shielded Room
Report No.	11220705H
Date	November 24, 2015
Temperature / Humidity	23deg. C / 45 % RH
Engineer	Tsubasa Takayama
Mode	Tx 11ac-20

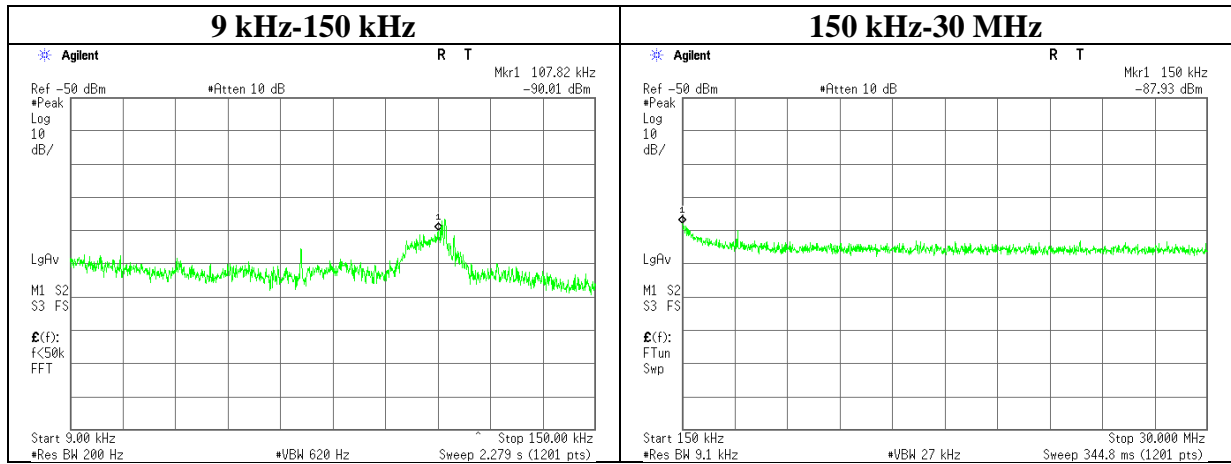

Frequency	Reading	Cable Loss	Attenuator	Antenna Gain	N	EIRP	Distance	Ground bounce	E	Limit	Margin	Remark
[kHz]	[dBm]	[dB]	[dB]	[dBi]	(Number of Output)	[dBm]	[m]	[dB]	(field strength) [dBuV/m]	[dBuV/m]	[dB]	
107.82	-90.0	0.00	9.8	6.0	2	-71.2	300	6.0	-9.9	26.9	36.8	
150.00	-87.9	0.00	9.8	6.0	2	-69.1	300	6.0	-7.8	24.0	31.8	

$E = \text{EIRP} - 20 \cdot \log(D) + \text{Ground bounce} + 104.8 \text{ [dBuV/m]}$

$\text{EIRP} = \text{Reading} + \text{Cable Loss} + \text{Attenuator} + \text{Antenna Gain} + 10 \cdot \log(N)$

Conducted Spurious Emission

Test place	Ise EMC Lab. No.7 Shielded Room
Report No.	11220705H
Date	November 24, 2015
Temperature / Humidity	23deg. C / 45 % RH
Engineer	Tsubasa Takayama
Mode	Tx 11ac-40

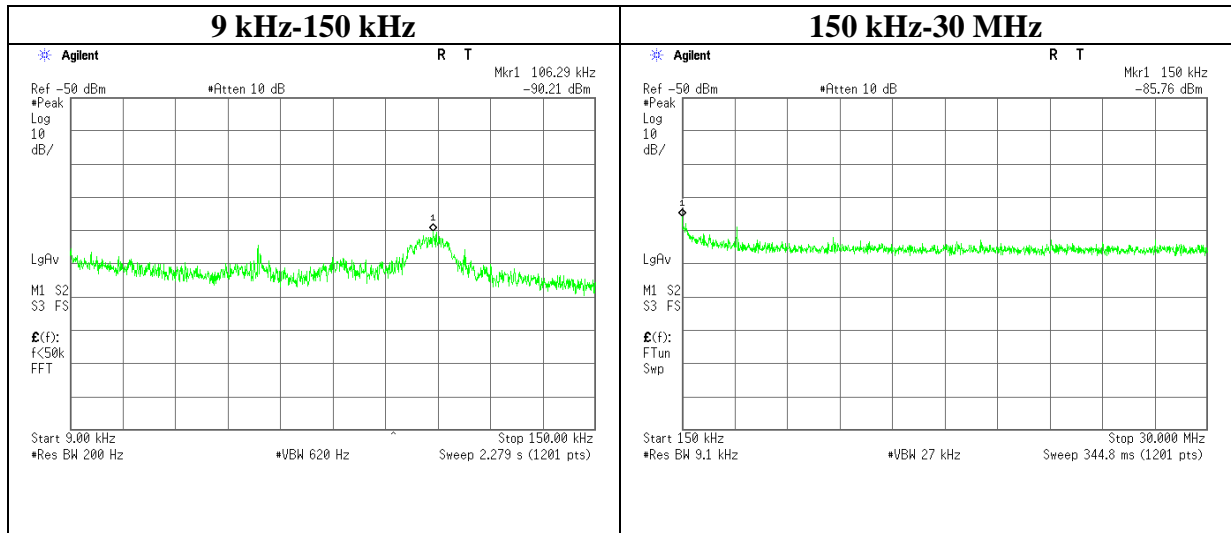

Frequency [kHz]	Reading [dBm]	Cable Loss [dB]	Attenuator [dB]	Antenna Gain [dBi]	N (Number of Output)	EIRP [dBm]	Distance [m]	Ground bounce [dB]	E (field strength) [dBuV/m]	Limit [dBuV/m]	Margin [dB]	Remark
106.29	-90.2	0.00	9.8	6.0	2	-71.4	300	6.0	-10.1	27.0	37.1	
150.00	-85.8	0.00	9.8	6.0	2	-66.9	300	6.0	-5.7	24.0	29.7	

$$E = \text{EIRP} - 20 \cdot \log(D) + \text{Ground bounce} + 104.8 \text{ [dBuV/m]}$$

$$\text{EIRP} = \text{Reading} + \text{Cable Loss} + \text{Attenuator} + \text{Antenna Gain} + 10 \cdot \log(N)$$

Conducted Spurious Emission

Test place	Ise EMC Lab. No.7 Shielded Room
Report No.	11220705H
Date	November 24, 2015
Temperature / Humidity	23deg. C / 45 % RH
Engineer	Tsubasa Takayama
Mode	Tx 11ac-80

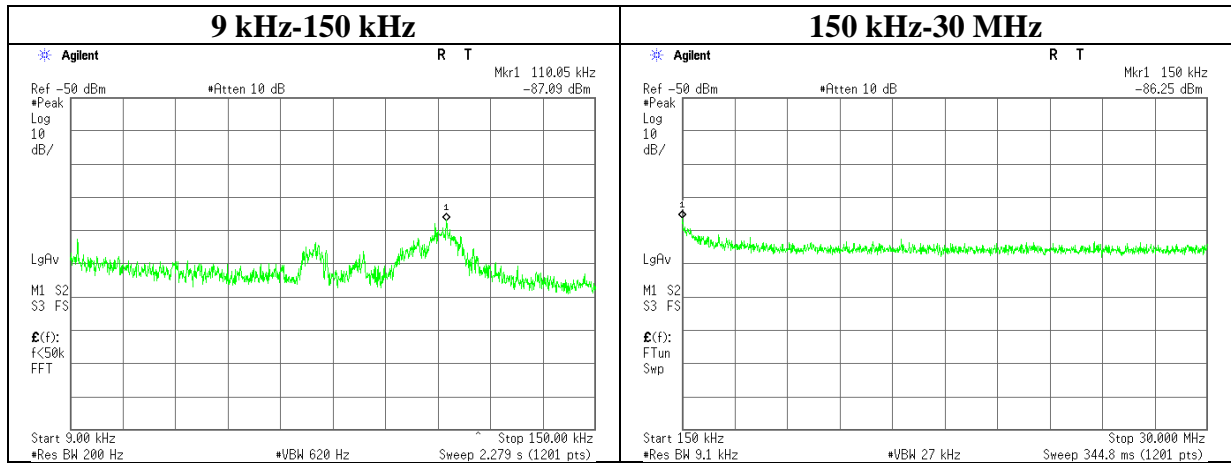

Frequency [kHz]	Reading [dBm]	Cable Loss [dB]	Attenuator [dB]	Antenna Gain [dBi]	N (Number of Output)	EIRP [dBm]	Distance [m]	Ground bounce [dB]	E (field strength) [dBuV/m]	Limit [dBuV/m]	Margin [dB]	Remark
110.05	-87.1	0.00	9.8	6.0	2	-68.3	300	6.0	-7.0	26.7	33.7	
150.00	-86.2	0.00	9.8	6.0	2	-67.4	300	6.0	-6.1	24.0	30.1	

$E = \text{EIRP} - 20 \cdot \log(D) + \text{Ground bounce} + 104.8 \text{ [dBuV/m]}$

$\text{EIRP} = \text{Reading} + \text{Cable Loss} + \text{Attenuator} + \text{Antenna Gain} + 10 \cdot \log(N)$

APPENDIX 2: Test instruments

Test equipment (1/2)

Control No.	Instrument	Manufacturer	Model No	Serial No	Test Item	Calibration Date * Interval(month)
MTR-01	Test Receiver	Rohde & Schwarz	ESI40	100084	RE	2015/11/28 * 12
MBA-05	Biconical Antenna	Schwarzbeck	BBA9106	1302	RE	2015/11/02 * 12
MLA-08	Logperiodic Antenna	Schwarzbeck	UKLP9140-A	N/A	RE	2015/11/03 * 12
MCC-50	Coaxial Cable	UL Japan	-	-	RE	2015/06/19 * 12
MAT-68	Attenuator	Anritsu	MP721B	6200961025	RE	2015/11/12 * 12
MPA-14	Pre Amplifier	SONOMA INSTRUMENT	310	260833	RE	2015/03/09 * 12
MPM-08	Power Meter	Anritsu	ML2495A	6K00003338	AT	2015/10/08 * 12
MPSE-11	Power sensor	Anritsu	MA2411B	011737	AT	2015/10/08 * 12
MAT-20	Attenuator(10dB)(above1 GHz)	HIROSE ELECTRIC CO.,LTD.	AT-110	-	AT	2015/01/08 * 12
MOS-14	Thermo-Hygrometer	Custom	CTH-201	1401	AT	2015/01/13 * 12
MSA-15	Spectrum Analyzer	Agilent	E4440A	MY46187105	AT	2015/11/11 * 12
MCC-138	Microwave cable	HUBER+SUHNER	SUCOFLEX 102	37953/2	AT	2015/10/08 * 12
MOS-19	Thermo-Hygrometer	Custom	CTH-201	0001	AT	2015/12/08 * 12
MPM-16	Power Meter	Agilent	8990B	MY51000271	AT	2015/04/01 * 12
MPSE-23	Power sensor	Agilent	N1923A	MY54070004	AT	2015/04/01 * 12
MPSE-22	Power sensor	Agilent	N1923A	MY54070003	AT	2015/04/01 * 12
MAT-22	Attenuator(10dB) 1-18GHz	Orient Microwave	BX10-0476-00	-	AT	2015/03/18 * 12
MAT-23	Attenuator(10dB) 1-18GHz	Orient Microwave	BX10-0476-00	-	AT	2015/03/13 * 12
MCC-109	Microwave Cable	Hirose Electric	W.FL-2LP-04N1 -A-(200)	-	AT	2015/08/05 * 12
MCC-111	Microwave Cable	Hirose Electric	W.FL-2LP-04N1 -A-(200)	-	AT	2015/08/05 * 12
MCC-171	Microwave Cable	Junkosha	MWX221	1409S494	AT	2015/03/04 * 12
MCC-144	Microwave Cable	Junkosha	MWX221	1207S407	AT	2015/08/06 * 12
MAEC-02	Semi Anechoic Chamber(NSA)	TDK	Semi Anechoic Chamber 3m	DA-06902	RE/CE	2015/07/01 * 12
MOS-22	Thermo-Hygrometer	Custom	CTH-201	0003	RE/CE	2015/01/13 * 12
MJM-14	Measure	KOMELON	KMC-36	-	RE/CE	-
COTS-MEMI	EMI measurement program	TSJ	TEPTO-DV	-	RE/CE	-
MSA-04	Spectrum Analyzer	Agilent	E4448A	US44300523	RE/CE	2015/11/06 * 12
MHA-06	Horn Antenna 1-18GHz	Schwarzbeck	BBHA9120D	254	RE	2015/02/05 * 12
MCC-168	Microwave Cable	Junkosha	MWX221	1408S016(1m) / 1409S492(5m)	RE	2015/09/24 * 12
MPA-10	Pre Amplifier	Agilent	8449B	3008A02142	RE	2015/01/28 * 12
MMM-01	Digital Tester	Fluke	FLUKE 26-3	78030611	RE	2015/08/19 * 12
MHF-16	High Pass Filter 7-20GHz	TOKIMEC	TF37NCCA	7001	RE	2015/09/15 * 12
MCC-176	Microwave Cable	Junkosha	MMX221-00500 DMSDMS	1502S303	RE	2015/03/27 * 12
MCC-172	Microwave Cable	Junkosha	MWX221	1409S495	AT	2015/03/04 * 12
MCC-38	Coaxial Cable	UL Japan	-	-	AT	2015/12/07 * 12
MAT-10	Attenuator(10dB)	Weinschel Corp	2	BL1173	AT	2015/11/10 * 12
MSA-10	Spectrum Analyzer	Agilent	E4448A	MY46180655	RE/AT	2015/02/26 * 12
MTR-08	Test Receiver	Rohde & Schwarz	ESCI	100767	CE	2015/09/02 * 12
MLS-23	LISN(AMN)	Schwarzbeck	NSLK8127	8127-729	CE(EUT)	2015/07/10 * 12
MCC-13	Coaxial Cable	Fujikura	3D-2W(12m)/5D -2W(5m)/5D-2 W(0.8m)/5D-2W (1m)	-	CE	2015/02/06 * 12
MAT-65	Attenuator(13dB)	JFW Industries, Inc.	50FP-013H2 N	-	CE	2015/01/29 * 12

UL Japan, Inc.

Ise EMC Lab.

4383-326 Asama-cho, Ise-shi, Mie-ken 516-0021 JAPAN

Telephone : +81 596 24 8999

Facsimile : +81 596 24 8124

Test equipment (2/2)

Control No.	Instrument	Manufacturer	Model No	Serial No	Test Item	Calibration Date * Interval(month)
MAEC-04	Semi Anechoic Chamber(NSA)	TDK	Semi Anechoic Chamber 3m	DA-10005	RE	2015/10/02 * 12
MOS-15	Thermo-Hygrometer	Custom	CTH-180	1501	RE	2015/01/13 * 12
MJM-26	Measure	KOMELON	KMC-36	-	RE	-
MHA-21	Horn Antenna 1-18GHz	Schwarzbeck	BBHA9120D	9120D-557	RE	2015/08/10 * 12
MCC-141	Microwave Cable	Junkosha	MWX221	1305S002R(1m) / 1405S146(5m)	RE	2015/06/22 * 12
MPA-12	MicroWave System Amplifier	Agilent	83017A	00650	RE	2015/10/01 * 12
MHA-17	Horn Antenna 15-40GHz	Schwarzbeck	BBHA9170	BBHA9170307	RE	2015/06/06 * 12
MMM-10	DIGITAL HiTESTER	Hioki	3805	051201148	RE	2015/01/16 * 12
MCC-54	Microwave Cable	Suhner	SUCOFLEX101	2873(1m) / 2876(5m)	RE	2015/03/09 * 12
MPA-22	Pre Amplifier	MITEQ, Inc	AMF-6F-260040 0-33-8P / AMF-4F-260040 0-33-8P	1871355 /1871328	RE	2015/09/03 * 12
MHA-29	Horn Antenna 26.5-40GHz	ETS LINDGREN	3160-10	00152399	RE	2015/09/04 * 12

The expiration date of the calibration is the end of the expired month.

All equipment is calibrated with valid calibrations. Each measurement data is traceable to the national or international standards.

As for some calibrations performed after the tested dates, those test equipment have been controlled by means of an unbroken chains of calibrations.

Test Item: **CE: Conducted emission**
 RE: Radiated Emission
 AT: Antenna Terminal Conducted test