



RADIO TEST REPORT

Test Report No. : 11232804H-R1

Applicant : PANASONIC CORPORATION OF NORTH AMERICA
Type of Equipment : Wireless Module
Model No. : WL12A
FCC ID : ACJ9TGWL12A
Test regulation : FCC Part 15 Subpart E: 2015
Test Result : Complied

1. This test report shall not be reproduced in full or partial, without the written approval of UL Japan, Inc.
2. The results in this report apply only to the sample tested.
3. This sample tested is in compliance with the above regulation.
4. The test results in this report are traceable to the national or international standards.
5. This test report must not be used by the customer to claim product certification, approval, or endorsement by NVLAP, NIST, or any agency of the Federal Government.
6. This test report covers Radio technical requirements. It does not cover administrative issues such as Manual or non-Radio test related Requirements. (if applicable)
7. This report is a revised version of 11232804H. 11232804H is replaced with this report.

Date of test: April 21 to 25, 2016

Representative test engineer:

T. Matsui

Tomoki Matsui
Engineer
Consumer Technology Division

Approved by:

T. Hatakeda

Takahiro Hatakeda
Engineer
Consumer Technology Division



NVLAP LAB CODE: 200572-0

This laboratory is accredited by the NVLAP LAB CODE 200572-0, U.S.A. The tests reported herein have been performed in accordance with its terms of accreditation.
*As for the range of Accreditation in NVLAP, you may refer to the WEB address,
http://japan.ul.com/resources/emc_accredited/

UL Japan, Inc.

Ise EMC Lab.

4383-326 Asama-cho, Ise-shi, Mie-ken 516-0021 JAPAN

Telephone : +81 596 24 8999

Facsimile : +81 596 24 8124

13-EM-F0429

CONTENTS	PAGE
SECTION 1: Customer information.....	4
SECTION 2: Equipment under test (E.U.T.).....	4
SECTION 3: Test specification, procedures & results.....	5
SECTION 4: Operation of E.U.T. during testing.....	8
SECTION 5: Conducted Emission.....	11
SECTION 6: Antenna Terminal Conducted Tests.....	12
APPENDIX 1: Test data	13
Conducted Emission	13
99 % Occupied Bandwidth.....	14
6 dB Bandwidth	17
Maximum Conducted Output Power	20
Average Output Power.....	28
Burst rate confirmation	33
Maximum Power Spectral Density	34
APPENDIX 2: Test instruments	40
APPENDIX 3: Photographs of test setup	41
Conducted Emission	41

SECTION 1: Customer information

Company Name : PANASONIC CORPORATION OF NORTH AMERICA
Address : Two Riverfront Plaza, 9th Floor, Newark, NJ 07102-5490

SECTION 2: Equipment under test (E.U.T.)

2.1 Identification of E.U.T.

Type of Equipment : Wireless Module
Model No. : WL12A
Serial No. : Refer to Section 4, Clause 4.2
Receipt Date of Sample : April 16, 2016
Modification of EUT : No Modification by the test lab

2.2 Product Description

Model: WL12A (referred to as the EUT in this report) is a Wireless Module.

Radio Specification

Tx Frequency Bands	802.11a/b/g/n: 2412 - 2462 MHz, b / g / HT20 / HT40 5180 - 5240 MHz, a / HT20 / HT40 5260 - 5320 MHz, a / HT20 / HT40 5500 - 5720 MHz, a / HT20 / HT40 5745 - 5825 MHz, a / HT20 / HT40 Bluetooth: 2402 - 2480 MHz
Modulation	802.11a/b/g/n : BPSK, QPSK, CCK, 16-QAM and 64-QAM Bluetooth 4.0+LE: GFSK, DQPSK, 8-DPSK

Antenna Specification

Part. No	Function	Type	Gain [dBi] <5700-5825MHz>	Remarks
DEUP2355(1)	Main	PIFA	2.47	
DEUP2355(2)	Aux	PIFA	2.07	
DEUP2067	Main	PIFA	-0.25	Installed in Host : CF-19
DEUP1851	Aux	PIFA	1.97	Installed in Host : CF-19

*As stated above, the gain of the antenna that is used with ACJ9TGWL12A is all under the 10 dBi, furthermore it is lower than the antenna gain 5.0 dBi of the Intel original.

The calculation in this report is used with Main : 2.47 dBi, Aux : 2.07 dBi.

UL Japan, Inc.

Ise EMC Lab.

4383-326 Asama-cho, Ise-shi, Mie-ken 516-0021 JAPAN

Telephone : +81 596 24 8999

Facsimile : +81 596 24 8124

SECTION 3: Test specification, procedures & results

3.1 Test Specification

Test Specification : FCC Part 15 Subpart E: 2015, final revised on November 23, 2015
*Some parts are effective on and after December 17, 2015 or December 23, 2015. The revision does not affect the test specification applied to the EUT.

Title : FCC 47CFR Part15 Radio Frequency Device Subpart E
Unlicensed National Information Infrastructure Devices
Section 15.407 General technical requirements

3.2 Procedures and results

Item	Test Procedure	Specification	Worst margin	Results	Remarks	
Conducted Emission	FCC: ANSI C63.10-2013	FCC: 15.407 (b) (6) / 15.207	QP 17.0 dB, 0.51680 MHz, L AV 17.5 dB, 1.22480 MHz, L	Complied	-	
	IC: RSS-Gen 8.8	IC: RSS-Gen 8.8				
26 dB Emission Bandwidth	FCC: KDB Publication Number 789033 D02 v01r02 662911 D01 v02r01 662911 D02 v01	FCC: 15.407 (a) (1) (2) (3)	See data	N/A	Conducted	
	IC: -	IC: -				
Maximum Conducted Output Power	FCC: KDB Publication Number 789033 D02 v01r02 662911 D01 v02r01 662911 D02 v01	FCC: 15.407 (a) (1) (2) (3)		6.2.1 (1) 6.2.2 (1) 6.2.3 (1) 6.2.4 (1)	Complied	Conducted
	IC: -	IC: RSS-247				
Maximum Power Spectral Density	FCC: KDB Publication Number 789033 D02 v01r02 662911 D01 v02r01 662911 D02 v01	FCC : 15.407 (a) (1) (2) (3)	6.2.1 (1) 6.2.2 (1) 6.2.3 (1) 6.2.4 (1)	Complied	Conducted	
	IC: -	IC: RSS-247				
Spurious Emission Restricted Band Edge	FCC: KDB Publication Number 926956 D01 U-NII Transition Plan v01r06 Questions 15 and 16 (c)(4)	FCC : 15.407 (b) (4) (ii) : 15.247 (d)	N/A	Complied *1)	-	
6 dB Emission Bandwidth	FCC: ANSI C63.10-2013	FCC: 15.407 (e)	See data	Complied	Conducted	
	IC: -	IC: RSS-247 6.2.4 (1)				

Note: UL Japan, Inc.'s EMI Work Procedures No. 13-EM-W0420 and 13-EM-W0422.

* In case any questions arise about test procedure, ANSI C63.10: 2013 is also referred.

*1) The Intel original data in Report file No.R84671 issued by Elliott Laboratories shows the compliance to 15.247 (d), so it also shows the compliance to 5GHz new rules including 15.407(b) (4) (ii).

The gain of the antenna used during RF testing is lower than one of the antenna Intel used during the original RF tests.

It is the same type antenna as the original one, and the antenna that is used with ACJ9TGWL12A also meets 15.407 (b) (4) (ii).

3.3 Addition to standard

Item	Test Procedure	Specification	Worst margin	Results	Remarks
99 % Occupied Band Width	RSS-Gen 6.6	IC: -	N/A	N/A	Conducted

Other than above, no addition, exclusion nor deviation has been made from the standard.

UL Japan, Inc.

Ise EMC Lab.

4383-326 Asama-cho, Ise-shi, Mie-ken 516-0021 JAPAN

Telephone : +81 596 24 8999

Facsimile : +81 596 24 8124

3.4 Uncertainty

EMI

The following uncertainties have been calculated to provide a confidence level of 95 % using a coverage factor $k=2$.
 Ise EMC Lab.

Antenna terminal test Uncertainty (+/-)							
Power meter		Conducted emission and Power density			Conducted emission		Channel power
Below 1 GHz	Above 1 GHz	Below 1 GHz	1 GHz -3 GHz	3 GHz -18 GHz	18 GHz -26.5 GHz	26.5 GHz -40 GHz	
0.9 dB	1.0 dB	1.4 dB	1.7 dB	2.8 dB	2.8 dB	2.9 dB	2.6 dB

Frequency range	Conducted emission using AMN(LISN) (+dB)
0.009 – 0.15MHz	3.5 dB
0.15 – 30MHz	2.9 dB

Conducted Emission test

The data listed in this test report has enough margin, more than the site margin.

3.5 Test Location

UL Japan, Inc. Ise EMC Lab. *NVLAP Lab. code: 200572-0
 4383-326 Asama-cho, Ise-shi, Mie-ken 516-0021 JAPAN
 Telephone: +81 596 24 8999, Facsimile: +81 596 24 8124

Test site	IC Registration Number	Width x Depth x Height (m)	Size of reference ground plane (m) / horizontal conducting plane	Other rooms	Maximum measurement distance
No.1 semi-anechoic chamber	2973C-1	19.2 x 11.2 x 7.7	7.0 x 6.0	No.1 Power source room	10 m
No.2 semi-anechoic chamber	2973C-2	7.5 x 5.8 x 5.2	4.0 x 4.0	-	3 m
No.3 semi-anechoic chamber	2973C-3	12.0 x 8.5 x 5.9	6.8 x 5.75	No.3 Preparation room	3 m
No.3 shielded room	-	4.0 x 6.0 x 2.7	N/A	-	-
No.4 semi-anechoic chamber	2973C-4	12.0 x 8.5 x 5.9	6.8 x 5.75	No.4 Preparation room	3 m
No.4 shielded room	-	4.0 x 6.0 x 2.7	N/A	-	-
No.5 semi-anechoic chamber	-	6.0 x 6.0 x 3.9	6.0 x 6.0	-	-
No.6 shielded room	-	4.0 x 4.5 x 2.7	4.0 x 4.5	-	-
No.6 measurement room	-	4.75 x 5.4 x 3.0	4.75 x 4.15	-	-
No.7 shielded room	-	4.7 x 7.5 x 2.7	4.7 x 7.5	-	-
No.8 measurement room	-	3.1 x 5.0 x 2.7	N/A	-	-
No.9 measurement room	-	8.8 x 4.6 x 2.8	2.4 x 2.4	-	-
No.11 measurement room	-	6.2 x 4.7 x 3.0	4.8 x 4.6	-	-

* Size of vertical conducting plane (for Conducted Emission test) : 2.0 x 2.0 m for No.1, No.2, No.3, and No.4 semi-anechoic chambers and No.3 and No.4 shielded rooms.

3.6 Test data, Test instruments, and Test set up

Refer to APPENDIX.

SECTION 4: Operation of E.U.T. during testing

4.1 Operating Mode(s)

Test operating mode was determined as follows according to “Section 1 of 6 802.11 a/b/g/n testing - Managing Complex Regulatory Approvals -” of TCB Council Workshop October 2009

Mode	Remarks*
IEEE 802.11a (11a)	6 Mbps, PN9
IEEE 802.11n SISO 20 MHz BW (11n-20)	MCS 7 (Long GI), PN9
IEEE 802.11n MIMO 20 MHz BW (11n-20)	MCS 15 (Long GI), PN9
IEEE 802.11n SISO 40 MHz BW (11n-40)	MCS 7 (Long GI), PN9
IEEE 802.11n MIMO 40 MHz BW (11n-40)	MCS 15 (Long GI), PN9

*Above worst rate was decided based on a maximum conducted output power rate check (reference data) result.

*Power of the EUT was set by the software as follows;

Power settings:

Mode	Frequency	Target Power[dBm]			
		SISO		MIMO	
		Antenna A	Antenna B	Antenna A	Antenna B
11 a	5745MHz	15.0	15.0	-	-
	5785MHz	15.0	15.0	-	-
	5825MHz	15.0	14.5	-	-
11 n-20	5745MHz	15.0	15.0	12.0	12.0
	5785MHz	15.0	15.0	12.0	12.0
	5825MHz	15.0	15.0	12.0	12.0
11 n-40	5755MHz	15.0	15.0	12.0	12.0
	5795MHz	15.0	15.0	12.0	12.0

Software: DRTU, Version 1.5.3-0335

*This setting of software is the worst case.

Any conditions under the normal use do not exceed the condition of setting.

In addition, end users cannot change the settings of the output power of the product.

*The details of Operation mode(s)

Test Item	Operating Mode	Tested Antenna	Tested Frequency
			Upper Band
Conducted Emission *1)	11n-40 Tx *2)	A+B	5755 MHz
99 % Occupied Bandwidth, 6 dB Bandwidth *1)	11a Tx	B	5745 MHz
	11n-20 Tx		5785 MHz
			5825 MHz
	11n-40 Tx	B	5755 MHz
			5795 MHz
Maximum Power Spectral Density *1)	11a Tx	A, B	5745 MHz
			5785 MHz
			5825 MHz
	11n-20 Tx	A+B	5745 MHz
			5785 MHz
			5825 MHz
	11n-40 Tx	A+B	5755 MHz
			5795 MHz
Maximum Conducted Output Power *1)	11a Tx	A, B	5745 MHz
			5785 MHz
			5825 MHz
	11n-20 Tx	A, B, A+B	5745 MHz
			5785 MHz
			5825 MHz
	11n-40 Tx	A, B, A+B	5755 MHz
			5795 MHz

*1) The test was only performed with UNII-3 band.

*2) The test was performed with the worst case.

The highest mode in Maximum conducted output power result was selected as the worst case.

The highest rate in Maximum conducted output power rate check (reference data) result was selected as the worst case.

UL Japan, Inc.

Ise EMC Lab.

4383-326 Asama-cho, Ise-shi, Mie-ken 516-0021 JAPAN

Telephone : +81 596 24 8999

Facsimile : +81 596 24 8124

4.2 Configuration and peripherals

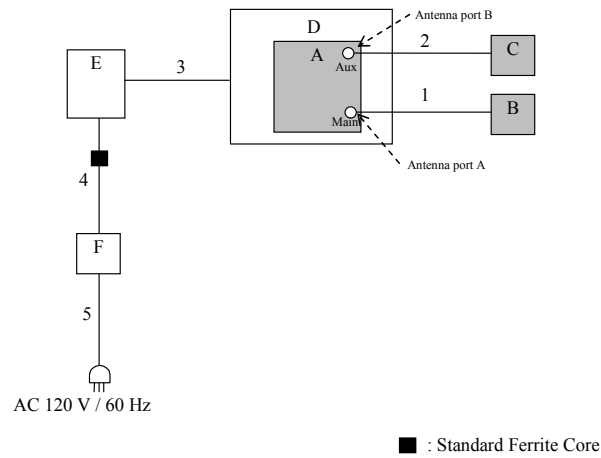

* Cabling and setup(s) were taken into consideration and test data was taken under worse case conditions.

Description of EUT and Support equipment

No.	Item	Model number	Serial number	Manufacturer	Remarks
A	Wireless Module	WL12A	R0359Z	Panasonic	EUT
B	Main antenna	DFUP2355(1)	-	Panasonic	EUT
C	Aux antenna	DFUP2355(2)	-	Panasonic	EUT
D	Jig board	-	-	-	-
E	Jig	-	-	-	-
F	AC Adapter	CF-AA5713A	5713AM113400405B	Panasonic	-

List of cables used

No.	Name	Length (m)	Shield		Remarks
			Cable	Connector	
1	Antenna Cable	0.25	Unshielded	Unshielded	-
2	Antenna Cable	0.18	Unshielded	Unshielded	-
3	Signal Cable	0.18	Unshielded	Unshielded	-
4	DC Cable	1.80	Unshielded	Unshielded	-
5	AC Cable	1.80	Unshielded	Unshielded	-

SECTION 5: Conducted Emission

Test Procedure and conditions

EUT was placed on a urethane platform of nominal size, 1.0 m by 1.5 m, raised 0.8 m above the conducting ground plane.

The rear of tabletop was located 40cm to the vertical conducting plane. The rear of EUT, including peripherals aligned and flushed with rear of tabletop. All other surfaces of tabletop were at least 80cm from any other grounded conducting surface. EUT was located 80cm from a Line Impedance Stabilization Network (LISN) / Artificial mains Network (AMN) and excess AC cable was bundled in center.

For the tests on EUT with other peripherals (as a whole system)

I/O cables that were connected to the peripherals were bundled in center. They were folded back and forth forming a bundle 30 cm to 40 cm long and were hanged at a 40 cm height to the ground plane. All unused 50 ohm connectors of the LISN (AMN) were resistivity terminated in 50 ohm when not connected to the measuring equipment.

The AC Mains Terminal Continuous disturbance Voltage has been measured with the EUT in a Semi Anechoic Chamber.

The EUT was connected to a LISN (AMN).

An overview sweep with peak detection has been performed.

The test results and limit are rounded off to one decimal place, so some differences might be observed.

Detector : QP and CISPR Average
Measurement range : 0.15 MHz-30 MHz
Test data : APPENDIX
Test result : Pass

SECTION 6: Antenna Terminal Conducted Tests

Test Procedure

The tests were made with below setting connected to the antenna port.

Test	Span	RBW	VBW	Sweep time	Detector	Trace	Instrument used and Test method
99 % Occupied Bandwidth *1)	Enough width to display emission skirts	1 % to 5 % of OBW	≥ 3 RBW	Auto	Peak	Max Hold	Spectrum Analyzer
6 dB Bandwidth	Enough to capture the emission	100 kHz	300 kHz	Auto	Peak	Max Hold	Spectrum Analyzer
Maximum Conducted Output Power	-	-	-	Auto	Average	-	Power Meter (Sensor: 80 MHz BW) (Method PM-G)
Maximum Power Spectral Density	Encompass the entire EBW	470 kHz *2)	≥ 3 RBW	Auto	RMS or Sample Power Averaging (200 times)	Clear Write	Spectrum Analyzer

* The test method was also referred to KDB 789033 D02 General UNII Test Procedures New Rules v01r02 "Guidelines for Compliance Testing of Unlicensed National Information Infrastructure (U-NII) Devices Part 15, Subpart E (Issued on April 8, 2016)".

*1) Peak hold was applied as Worst-case measurement.

*2) FCC standard says that RBW is set to be 500 kHz for 5.725 GHz-5.850 GHz, but it is not possible with spectrum analyzer, so $10\log(500\text{ kHz}/470\text{ kHz})$ was added to the test result.

The test results and limit are rounded off to two decimals place, so some differences might be observed.

Test data : **APPENDIX**
Test result : **Pass**

APPENDIX 1: Test data

Conducted Emission

DATA OF CONDUCTED EMISSION TEST

UL Japan, Inc. Ise EMC Lab. No.3 Semi Anechoic Chamber
 Date : 2016/04/25

Report No. : 11232804H

Temp./Humi. : 21deg. C / 55% RH
 Engineer : Tomoki Matsui

Mode / Remarks : Tx 11n-40 5755MHz

LIMIT : FCC15.207 QP
 FCC15.207 AV

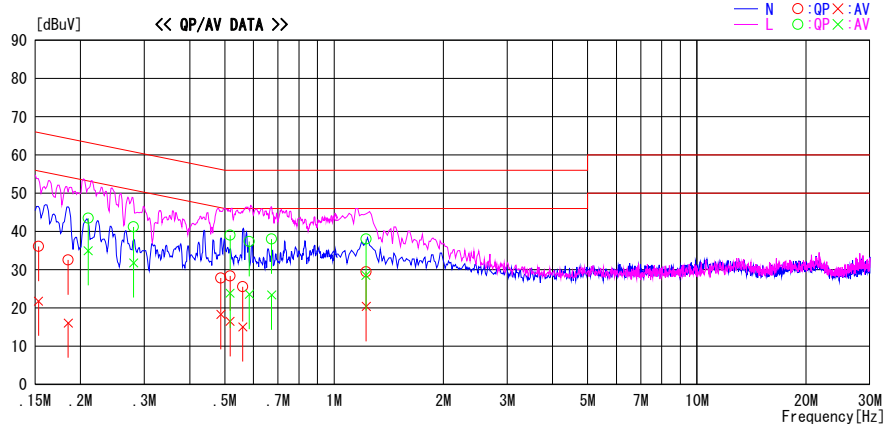

Frequency [MHz]	Reading Level		Corr. Factor	Results		Limit		Margin		Phase	Comment
	QP [dBuV]	AV [dBuV]		QP [dBuV]	AV [dBuV]	QP [dBuV]	AV [dBuV]	QP [dB]	AV [dB]		
0.15320	22.9	8.6	13.2	36.1	21.8	65.8	55.8	29.7	34.0	N	
0.18500	19.4	2.9	13.2	32.6	16.1	64.3	54.3	31.7	38.2	N	
0.48760	14.5	5.0	13.3	27.8	18.3	56.2	46.2	28.4	27.9	N	
0.51660	15.1	3.2	13.3	28.4	16.5	56.0	46.0	27.6	29.5	N	
0.56000	12.3	1.8	13.3	25.6	15.1	56.0	46.0	30.4	30.9	N	
1.22560	16.1	7.0	13.4	29.5	20.4	56.0	46.0	26.5	25.6	N	
0.21000	30.3	21.8	13.2	43.5	35.0	63.2	53.2	19.7	18.2	L	
0.28016	28.0	18.6	13.2	41.2	31.8	60.8	50.8	19.6	19.0	L	
0.51680	25.7	10.6	13.3	39.0	23.9	56.0	46.0	17.0	22.1	L	
0.58400	24.1	10.3	13.3	37.4	23.6	56.0	46.0	18.6	22.4	L	
0.67260	24.7	10.1	13.3	38.0	23.4	56.0	46.0	18.0	22.6	L	
1.22480	24.6	15.1	13.4	38.0	28.5	56.0	46.0	18.0	17.5	L	

CHART : WITH FACTOR. Peak hold data. CALCULATION : RESULT = READING + C.F (LISN + ATTN + CABLE)
 Except for the above table : adequate margin data below the limits.

99 % Occupied Bandwidth

Test place Ise EMC Lab. No.7 Shielded Room
Report No. 11232804H
Date April 22, 2016
Temperature / Humidity 22deg. C / 61 % RH
Engineer Yutaka Yoshida
Mode Tx

Mode	Antenna	Tested Frequency [MHz]	99 % Occupied Bandwidth [MHz]	Limit [MHz]
11a 6Mbps	Antenna B	5745	16.948	-
		5785	16.983	-
		5825	17.017	-
11n-20 MCS15(Long)	Antenna B	5745	17.781	-
		5785	17.786	-
		5825	17.766	-
11n-40 MCS15(Long)	Antenna B	5775	36.160	-
		5795	36.175	-

99 % Occupied Bandwidth

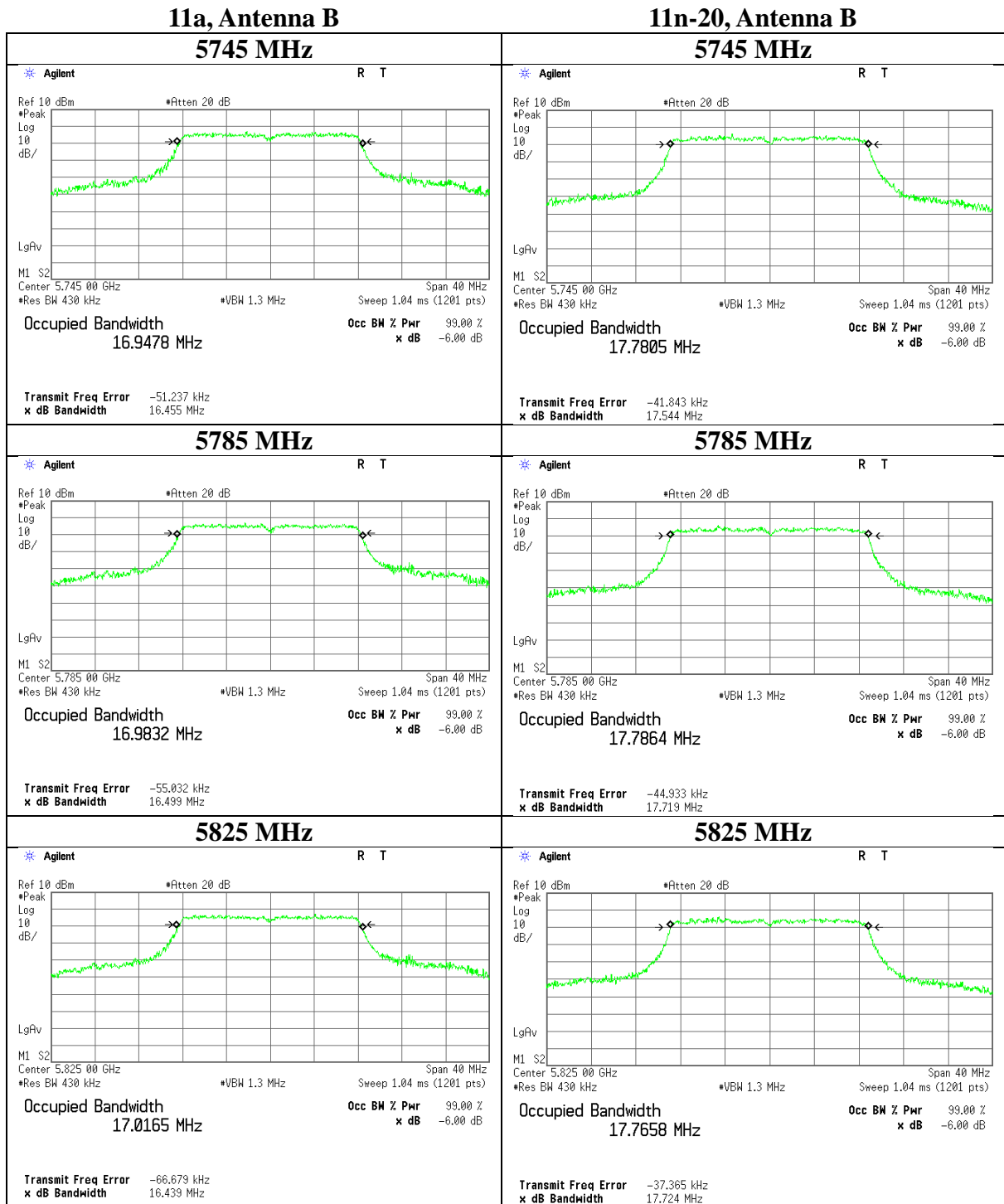

UL Japan, Inc.

Ise EMC Lab.

4383-326 Asama-cho, Ise-shi, Mie-ken 516-0021 JAPAN

Telephone : +81 596 24 8999

Facsimile : +81 596 24 8124

99 % Occupied Bandwidth

11n-40, Antenna B

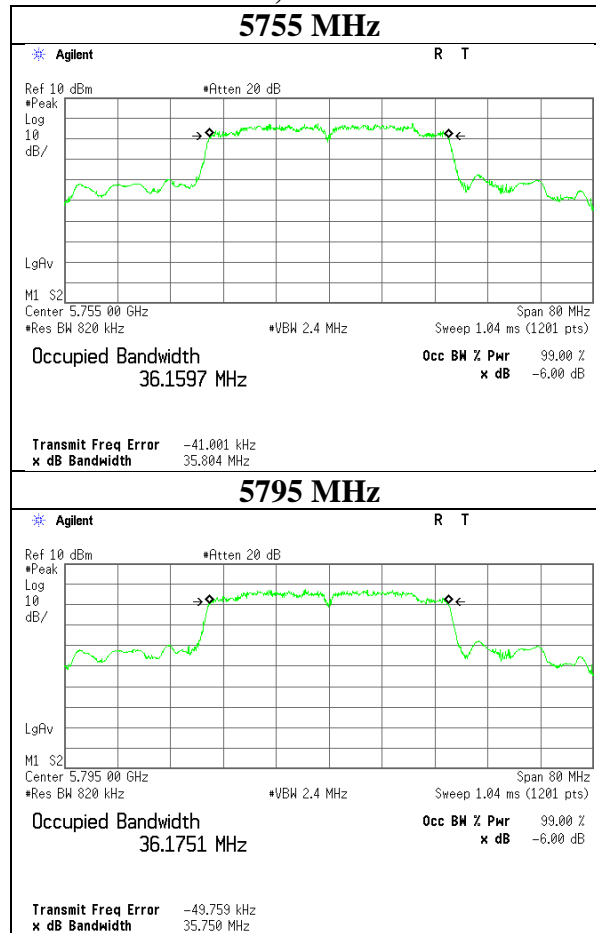

6 dB Bandwidth

Test place Ise EMC Lab. No.7 Shielded Room
Report No. 11232804H
Date April 22, 2016
Temperature / Humidity 22deg. C / 61 % RH
Engineer Yutaka Yoshida
Mode Tx

Mode	Antenna	Tested Frequency [MHz]	6 dB Bandwidth [MHz]	Limit [kHz]
11a 6Mbps	Antenna B	5745	16.335	> 500
		5785	16.349	> 500
		5825	16.351	> 500
11n-20 MCS15(Long)	Antenna B	5745	17.604	> 500
		5785	17.647	> 500
		5825	17.644	> 500
11n-40 MCS15(Long)	Antenna B	5775	35.187	> 500
		5795	35.176	> 500

6 dB Bandwidth

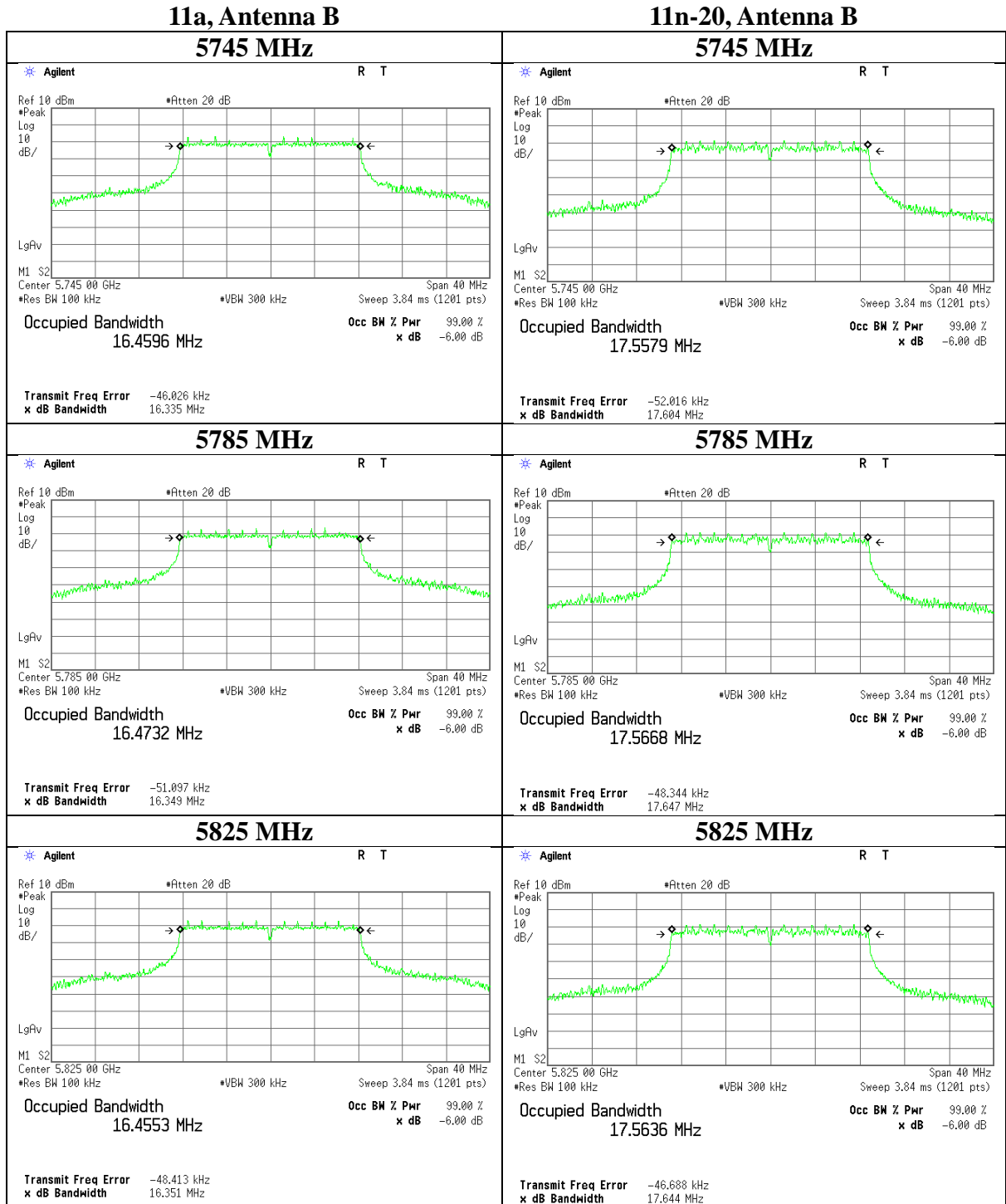

6 dB Bandwidth

11n-40, Antenna B

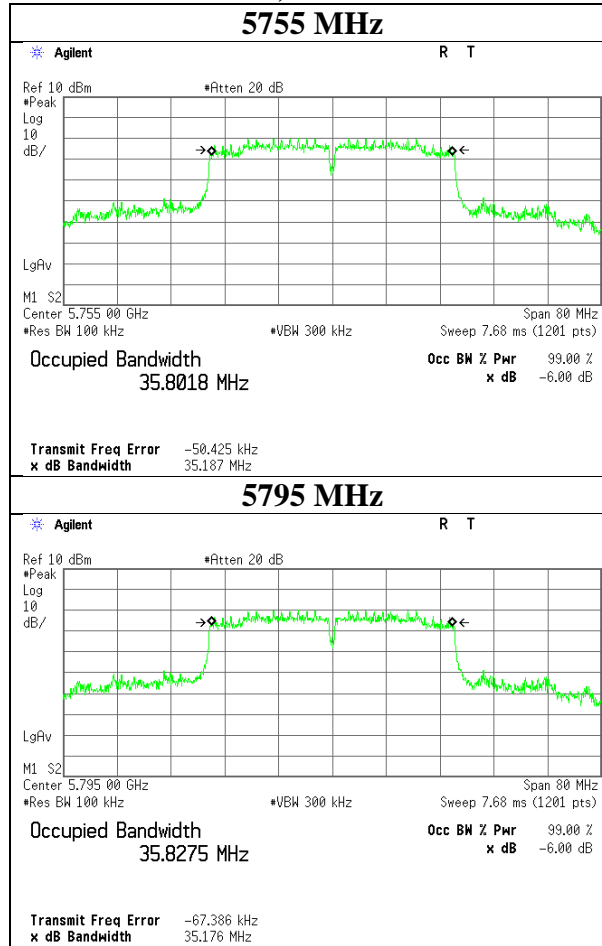

UL Japan, Inc.

Ise EMC Lab.

4383-326 Asama-cho, Ise-shi, Mie-ken 516-0021 JAPAN

Telephone : +81 596 24 8999

Facsimile : +81 596 24 8124

Maximum Conducted Output Power

Test place : Ise EMC Lab. No.7 Shielded Room
 Report No. : 11232804H
 Date : April 22, 2016
 Temperature / Humidity : 22deg. C / 61 % RH
 Engineer : Yutaka Yoshida
 Mode : Tx 11a 6Mbps

Antenna A Method PM-G is used. Applied limit: 15.407, mobile and portable client device

Tested Frequency [MHz]	Power Meter Reading [dBm]	Cable Loss [dB]	Atten. Loss [dB]	Duty Factor [dB]	Antenna Gain [dBi]	26 dB EBW (B for FCC) [MHz]	99% OBW (B for IC) [MHz]	Conducted Power				e.i.r.p.			
								Result [dBm]	[mW]	Limit [dBm]	Margin [dB]	Result [dBm]	[mW]	Limit [dBm]	Margin [dB]
5745	14.83	0.00	0.00	0.00	2.47	-	-	14.83	30.41	30.00	15.17	17.30	53.70	36.00	18.70
5785	14.87	0.00	0.00	0.00	2.47	-	-	14.87	30.69	30.00	15.13	17.34	54.20	36.00	18.66
5825	14.82	0.00	0.00	0.00	2.47	-	-	14.82	30.34	30.00	15.18	17.29	53.58	36.00	18.71

Sample Calculation:

Conducted Power Result = Reading + Cable Loss + Atten. Loss + Duty Factor

Cable Loss and Atten. Loss are included in Power Meter Reading value.

e.i.r.p. Result = Conducted Power Result + Antenna Gain

Antenna B Method PM-G is used. Applied limit: 15.407, mobile and portable client device

Tested Frequency [MHz]	Power Meter Reading [dBm]	Cable Loss [dB]	Atten. Loss [dB]	Duty Factor [dB]	Antenna Gain [dBi]	26 dB EBW (B for FCC) [MHz]	99% OBW (B for IC) [MHz]	Conducted Power				e.i.r.p.			
								Result [dBm]	[mW]	Limit [dBm]	Margin [dB]	Result [dBm]	[mW]	Limit [dBm]	Margin [dB]
5745	14.69	0.00	0.00	0.00	2.07	-	-	14.69	29.44	30.00	15.31	16.76	47.42	36.00	19.24
5785	14.74	0.00	0.00	0.00	2.07	-	-	14.74	29.79	30.00	15.26	16.81	47.97	36.00	19.19
5825	14.72	0.00	0.00	0.00	2.07	-	-	14.72	29.65	30.00	15.28	16.79	47.75	36.00	19.21

Sample Calculation:

Conducted Power Result = Reading + Cable Loss + Atten. Loss + Duty Factor

Cable Loss and Atten. Loss are included in Power Meter Reading value.

e.i.r.p. Result = Conducted Power Result + Antenna Gain

Maximum Conducted Output Power

Test place : Ise EMC Lab. No.7 Shielded Room
 Report No. : 11232804H
 Date : April 22, 2016
 Temperature / Humidity : 22deg. C / 61 % RH
 Engineer : Yutaka Yoshida
 Mode : Tx 11n-20 MCS7(Long)

Antenna A Method PM-G is used. Applied limit: 15.407, mobile and portable client device

Tested Frequency [MHz]	Power Meter Reading [dBm]	Cable Loss [dB]	Atten. Loss [dB]	Duty Factor [dB]	Antenna Gain [dBi]	26 dB EBW (B for FCC) [MHz]	99% OBW (B for IC) [MHz]	Conducted Power				e.i.r.p.			
								Result [dBm]	[mW]	Limit [dBm]	Margin [dB]	Result [dBm]	[mW]	Limit [dBm]	Margin [dB]
5745	14.98	0.00	0.00	0.00	2.47	-	-	14.98	31.48	30.00	15.02	17.45	55.59	36.00	18.55
5785	15.03	0.00	0.00	0.00	2.47	-	-	15.03	31.84	30.00	14.97	17.50	56.23	36.00	18.50
5825	15.03	0.00	0.00	0.00	2.47	-	-	15.03	31.84	30.00	14.97	17.50	56.23	36.00	18.50

Sample Calculation:

Conducted Power Result = Reading + Cable Loss + Atten. Loss + Duty Factor

Cable Loss and Atten. Loss are included in Power Meter Reading value.

e.i.r.p. Result = Conducted Power Result + Antenna Gain

Antenna B Method PM-G is used. Applied limit: 15.407, mobile and portable client device

Tested Frequency [MHz]	Power Meter Reading [dBm]	Cable Loss [dB]	Atten. Loss [dB]	Duty Factor [dB]	Antenna Gain [dBi]	26 dB EBW (B for FCC) [MHz]	99% OBW (B for IC) [MHz]	Conducted Power				e.i.r.p.			
								Result [dBm]	[mW]	Limit [dBm]	Margin [dB]	Result [dBm]	[mW]	Limit [dBm]	Margin [dB]
5745	14.93	0.00	0.00	0.00	2.07	-	-	14.93	31.12	30.00	15.07	17.00	50.12	36.00	19.00
5785	15.01	0.00	0.00	0.00	2.07	-	-	15.01	31.70	30.00	14.99	17.08	51.05	36.00	18.92
5825	14.94	0.00	0.00	0.00	2.07	-	-	14.94	31.19	30.00	15.06	17.01	50.23	36.00	18.99

Sample Calculation:

Conducted Power Result = Reading + Cable Loss + Atten. Loss + Duty Factor

Cable Loss and Atten. Loss are included in Power Meter Reading value.

e.i.r.p. Result = Conducted Power Result + Antenna Gain

Maximum Conducted Output Power

Test place : Ise EMC Lab. No.7 Shielded Room
 Report No. : 11232804H
 Date : April 22, 2016
 Temperature / Humidity : 22deg. C / 61 % RH
 Engineer : Yutaka Yoshida
 Mode : Tx 11n-20 MCS15(Long)

Tested Frequency [MHz]	26 dB EBW (B for FCC) [MHz]	99% OBW (B for 1C) [MHz]	Conducted power						e.i.r.p.					
			Antenna			Result [dBm]	Limit [dBm]	Margin [dB]	Antenna			Result [dBm]	Limit [dBm]	Margin [dB]
A [mW]	B [mW]	Sum [mW]	A [mW]	B [mW]	Sum [mW]									
5745	-	-	15.92	16.33	32.25	15.09	30.00	14.91	28.12	28.84	56.96	17.56	36.00	18.44
5785	-	-	15.89	16.07	31.95	15.05	30.00	14.95	28.05	28.38	56.43	17.52	36.00	18.48
5825	-	-	15.63	15.70	31.34	14.96	30.00	15.04	27.61	27.73	55.34	17.43	36.00	18.57

Antenna A							Antenna B						
Tested Frequency [MHz]	Duty Factor [dB]	Power Meter Reading [dBm]	Cable Loss [dB]	Atten. Loss [dB]	Antenna Gain [dBi]	Result		Power Meter Reading [dBm]	Cable Loss [dB]	Atten. Loss [dB]	Antenna Gain [dBi]	Result	
						Cond. Power [dBm]	e.i.r.p. [dBm]					Cond. Power [dBm]	e.i.r.p. [dBm]
5745	0.00	12.02	0.00	0.00	2.47	12.02	14.49	12.13	0.00	0.00	2.47	12.13	14.60
5785	0.00	12.01	0.00	0.00	2.47	12.01	14.48	12.06	0.00	0.00	2.47	12.06	14.53
5825	0.00	11.94	0.00	0.00	2.47	11.94	14.41	11.96	0.00	0.00	2.47	11.96	14.43

Sample Calculation:

Conducted Power Result = Reading + Cable Loss + Atten. Loss + Duty Factor

Cable Loss and Atten. Loss are included in Power Meter Reading value.

e.i.r.p. Result = Conducted Power Result + Antenna Gain

Antenna directional Gain = $G_{ANT\ MAX} + 10 \log(N_{ANT} / N_{SS})$

Maximum Conducted Output Power

Test place : Ise EMC Lab. No.7 Shielded Room
 Report No. : 11232804H
 Date : April 22, 2016
 Temperature / Humidity : 22deg. C / 61 % RH
 Engineer : Yutaka Yoshida
 Mode : Tx 11n-40 MCS7(Long)

Antenna A Method PM-G is used. Applied limit: 15.407, mobile and portable client device

Tested Frequency [MHz]	Power Meter Reading [dBm]	Cable Loss [dB]	Atten. Loss [dB]	Duty Factor [dB]	Antenna Gain [dBi]	26 dB EBW (B for FCC) [MHz]	99% OBW (B for 1C) [MHz]	Conducted Power			e.i.r.p.				
								Result [dBm]	Limit [dBm]	Margin [dB]	Result [dBm]	Limit [dBm]	Margin [dB]	Result [mW]	Limit [dBm]
5755	15.21	0.00	0.00	0.00	2.47	-	-	15.21	33.19	30.00	14.79	17.68	58.61	36.00	18.32
5795	15.27	0.00	0.00	0.00	2.47	-	-	15.27	33.65	30.00	14.73	17.74	59.43	36.00	18.26

Sample Calculation:

Conducted Power Result = Reading + Cable Loss + Atten. Loss + Duty Factor

Cable Loss and Atten. Loss are included in Power Meter Reading value.

e.i.r.p. Result = Conducted Power Result + Antenna Gain

Antenna B Method PM-G is used. Applied limit: 15.407, mobile and portable client device

Tested Frequency [MHz]	Power Meter Reading [dBm]	Cable Loss [dB]	Atten. Loss [dB]	Duty Factor [dB]	Antenna Gain [dBi]	26 dB EBW (B for FCC) [MHz]	99% OBW (B for 1C) [MHz]	Conducted Power			e.i.r.p.				
								Result [dBm]	Limit [dBm]	Margin [dB]	Result [dBm]	Limit [dBm]	Margin [dB]	Result [mW]	Limit [dBm]
5755	15.27	0.00	0.00	0.00	2.07	-	-	15.27	33.65	30.00	14.73	17.34	54.20	36.00	18.66
5795	15.05	0.00	0.00	0.00	2.07	-	-	15.05	31.99	30.00	14.95	17.12	51.52	36.00	18.88

Sample Calculation:

Conducted Power Result = Reading + Cable Loss + Atten. Loss + Duty Factor

Cable Loss and Atten. Loss are included in Power Meter Reading value.

e.i.r.p. Result = Conducted Power Result + Antenna Gain

Maximum Conducted Output Power

Test place : Ise EMC Lab. No.7 Shielded Room
 Report No. : 11232804H
 Date : April 22, 2016
 Temperature / Humidity : 22deg. C / 61 % RH
 Engineer : Yutaka Yoshida
 Mode : Tx 11n-40 MCS15(Long)

Antenna A+B Method PM-G is used. Applied limit: 15.407, mobile and portable client device

Tested Frequency [MHz]	26 dB EBW (B for FCC) [MHz]	99% OBW (B for IC) [MHz]	Conducted power						e.i.r.p.					
			Antenna			Result [dBm]	Limit [dBm]	Margin [dB]	Antenna			Result [dBm]	Limit [dBm]	Margin [dB]
A [mW]	B [mW]	Sum [mW]	A [mW]	B [mW]	Sum [mW]									
5755	-	-	17.62	17.82	35.44	15.50	30.00	14.50	31.12	31.48	62.59	17.97	36.00	18.03
5795	-	-	17.78	15.96	33.74	15.28	30.00	14.72	31.41	28.18	59.59	17.75	36.00	18.25

Antenna A							Antenna B						
Tested Frequency [MHz]	Duty Factor [dB]	Power Meter Reading [dBm]	Cable Loss [dB]	Atten. Loss [dB]	Antenna Gain [dBi]	Result		Power Meter Reading [dBm]	Cable Loss [dB]	Atten. Loss [dB]	Antenna Gain [dBi]	Result	
						Cond. Power [dBm]	e.i.r.p. [dBm]					Cond. Power [dBm]	e.i.r.p. [dBm]
5755	0.00	12.46	0.00	0.00	2.47	12.46	14.93	12.51	0.00	0.00	2.47	12.51	14.98
5795	0.00	12.50	0.00	0.00	2.47	12.50	14.97	12.03	0.00	0.00	2.47	12.03	14.50

Sample Calculation:

Conducted Power Result = Reading + Cable Loss + Atten. Loss + Duty Factor

Cable Loss and Atten. Loss are included in Power Meter Reading value.

e.i.r.p. Result = Conducted Power Result + Antenna Gain

Antenna directional Gain = $G_{ANT\ MAX} + 10 \log(N_{ANT} / N_{SS})$

Maximum Conducted Output Power
(Reference data)

Test place : Ise EMC Lab. No.3 Measurement Room
 Report No. : 11232804H
 Date : April 21, 2016
 Temperature / Humidity : 22deg. C / 52 % RH
 Engineer : Yutaka Yoshida
 Mode : Tx 11a

5745 MHz Antenna A Method PM-G is used

Mode	Rate Mbps	Reading(AV) : On time only Antenna A		Remarks
		[dBm]	[mW]	
11a	6	14.83	30.41	*
	9	14.75	29.85	
	12	14.74	29.79	
	18	14.80	30.20	
	24	14.66	29.24	
	36	14.72	29.65	
	48	14.81	30.27	
	54	14.79	30.13	

* Worst rate

Sample Calculation:

All comparison were carried out on same frequency and measurement factors.

5745 MHz Antenna B Method PM-G is used

Mode	Rate Mbps	Reading(AV) : On time only Antenna B		Remarks
		[dBm]	[mW]	
11a	6	14.69	29.44	*
	9	14.59	28.77	
	12	14.62	28.97	
	18	14.65	29.17	
	24	14.55	28.51	
	36	14.60	28.84	
	48	14.67	29.31	
	54	14.67	29.31	

* Worst rate

Sample Calculation:

All comparison were carried out on same frequency and measurement factors.

Maximum Conducted Output Power
(Reference data)

Test place : Ise EMC Lab. No.3 Measurement Room
Report No. : 11232804H
Date : April 21, 2016
Temperature / Humidity : 22deg. C / 52 % RH
Engineer : Yutaka Yoshida
Mode : Tx 11n-20

5745 MHz Method PM-G is used

Mode	MCS Index Number	Reading(AV) : On time only Antenna A		Reading(AV) : On time only Antenna B		Result(AV) : On time only Antenna A + B		Remarks
		[dBm]	[mW]	[dBm]	[mW]	[dBm]	[mW]	
11n-20 (SISO)	0	14.92	31.05	14.76	29.92	-	-	
	1	14.75	29.85	14.67	29.31	-	-	
	2	14.90	30.90	14.82	30.34	-	-	
	3	14.91	30.97	14.83	30.41	-	-	
	4	14.95	31.26	14.86	30.62	-	-	
	5	14.97	31.41	14.90	30.90	-	-	
	6	14.96	31.33	14.92	31.05	-	-	
	7	14.98	31.48	14.93	31.12	-	-	*
11n-20 (MIMO)	8	11.73	14.89	11.76	15.00	14.76	29.89	
	9	11.75	14.96	11.80	15.14	14.79	30.10	
	10	11.77	15.03	11.82	15.21	14.81	30.24	
	11	11.94	15.63	11.75	14.96	14.86	30.59	
	12	11.83	15.24	11.90	15.49	14.88	30.73	
	13	11.95	15.67	12.03	15.96	15.00	31.63	
	14	11.96	15.70	12.05	16.03	15.02	31.74	
		15	12.02	15.92	12.13	16.33	15.09	32.25

* Worst rate

Sample Calculation:

All comparison were carried out on same frequency and measurement factors.

5745MHz Method PM-G is used

MCS Index Number	GI	Reading(AV) : On time only Antenna A		Reading(AV) : On time only Antenna B		Result(AV) : On time only Antenna A + B		Remarks
		[dBm]	[mW]	[dBm]	[mW]	[dBm]	[mW]	
7	Long	14.98	31.48	14.93	31.12	-	-	*
7	Short	14.96	31.33	14.92	31.05	-	-	
15	Long	12.02	15.92	12.13	16.33	15.09	32.25	*
15	Short	12.00	15.85	12.10	16.22	15.06	32.07	

* Worst GI

All comparison were carried out on same frequency and measurement factors.

Maximum Conducted Output Power (Reference data)

Test place : Ise EMC Lab. No.3 Measurement Room
 Report No. : 11232804H
 Date : April 21, 2016
 Temperature / Humidity : 22deg. C / 52 % RH
 Engineer : Yutaka Yoshida
 Mode : Tx 11n-40

5755 MHz Method PM-G is used

Mode	MCS Index Number	Reading(AV) : On time only Antenna A		Reading(AV) : On time only Antenna B		Result(AV) : On time only Antenna A + B		Remarks
		[dBm]	[mW]	[dBm]	[mW]	[dBm]	[mW]	
11n-40 (SISO)	0	14.98	31.48	15.00	31.62	-	-	
	1	15.12	32.51	15.11	32.43	-	-	
	2	15.08	32.21	15.13	32.58	-	-	
	3	15.03	31.84	15.04	31.92	-	-	
	4	15.07	32.14	15.16	32.81	-	-	
	5	15.11	32.43	15.20	33.11	-	-	
	6	15.18	32.96	15.26	33.57	-	-	
	7	15.21	33.19	15.30	33.88	-	-	*
11n-40 (MIMO)	8	12.02	15.92	12.02	15.92	15.03	31.84	
	9	12.15	16.41	12.13	16.33	15.15	32.74	
	10	12.21	16.63	12.21	16.63	15.22	33.27	
	11	12.20	16.60	12.24	16.75	15.23	33.35	
	12	12.33	17.10	12.28	16.90	15.32	34.00	
	13	12.42	17.46	12.46	17.62	15.45	35.08	
	14	12.41	17.42	12.45	17.58	15.44	35.00	
	15	12.46	17.62	12.51	17.82	15.50	35.44	*

* Worst rate

Sample Calculation:

All comparison were carried out on same frequency and measurement factors.

5745MHz Method PM-G is used

MCS Index Number	GI	Reading(AV) : On time only Antenna A		Reading(AV) : On time only Antenna B		Result(AV) : On time only Antenna A + B		Remarks
		[dBm]	[mW]	[dBm]	[mW]	[dBm]	[mW]	
7	Long	15.21	33.19	15.30	33.88	-	-	*
7	Short	15.20	33.11	15.28	33.73	-	-	
15	Long	12.46	17.62	12.51	17.82	15.50	35.44	*
15	Short	12.46	17.62	12.50	17.78	15.49	35.40	

* Worst GI

All comparison were carried out on same frequency and measurement factors.

Average Output Power
(Reference data for RF Exposure)

Test place : Ise EMC Lab. No.7 Shielded Room
 Report No. : 11232804H
 Date : April 22, 2016
 Temperature / Humidity : 22deg. C / 61 % RH
 Engineer : Yutaka Yoshida
 Mode : Tx 11a 6Mbps

Antenna A Timed Average

Tested Frequency [MHz]	Power Meter Reading [dBm]	Cable Loss [dB]	Atten. Loss [dB]	Timed Average Power			
				Result		Limit	Margin
				[dBm]	[mW]	[dBm]	[dB]
5745	14.76	0.00	0.00	14.76	29.92	30.00	15.24
5785	14.80	0.00	0.00	14.80	30.20	30.00	15.20
5825	14.78	0.00	0.00	14.78	30.06	30.00	15.22

Sample Calculation:
 Timed Average Power Result = Reading + Cable Loss + Atten. Loss
 Cable Loss and Atten. Loss. are included in Power Meter Reading value.

Antenna B Timed Average

Tested Frequency [MHz]	Power Meter Reading [dBm]	Cable Loss [dB]	Atten. Loss [dB]	Timed Average Power			
				Result		Limit	Margin
				[dBm]	[mW]	[dBm]	[dB]
5745	14.62	0.00	0.00	14.62	28.97	30.00	15.38
5785	14.67	0.00	0.00	14.67	29.31	30.00	15.33
5825	14.49	0.00	0.00	14.49	28.12	30.00	15.51

Sample Calculation:
 Timed Average Power Result = Reading + Cable Loss + Atten. Loss
 Cable Loss and Atten. Loss. are included in Power Meter Reading value.

The test was performed with condition that obtained the maximum timed-average power for comparing power of Tune-up upper limit.

Average Output Power
(Reference data for RF Exposure)

Test place : Ise EMC Lab. No.7 Shielded Room
 Report No. : 11232804H
 Date : April 22, 2016
 Temperature / Humidity : 22deg. C / 61 % RH
 Engineer : Yutaka Yoshida
 Mode : Tx 11n-20 MCS0(Long)

Antenna A Timed Average

Tested Frequency [MHz]	Power Meter Reading [dBm]	Cable Loss [dB]	Atten. Loss [dB]	Timed Average Power			
				Result		Limit	Margin
				[dBm]	[mW]	[dBm]	[dB]
5745	14.85	0.00	0.00	14.85	30.55	30.00	15.15
5785	14.87	0.00	0.00	14.87	30.69	30.00	15.13
5825	14.78	0.00	0.00	14.78	30.06	30.00	15.22

Sample Calculation:
 Timed Average Power Result = Reading + Cable Loss + Atten. Loss
 Cable Loss and Atten. Loss. are included in Power Meter Reading value.

Antenna B Timed Average

Tested Frequency [MHz]	Power Meter Reading [dBm]	Cable Loss [dB]	Atten. Loss [dB]	Timed Average Power			
				Result		Limit	Margin
				[dBm]	[mW]	[dBm]	[dB]
5745	14.69	0.00	0.00	14.69	29.44	30.00	15.31
5785	14.72	0.00	0.00	14.72	29.65	30.00	15.28
5825	14.65	0.00	0.00	14.65	29.17	30.00	15.35

Sample Calculation:
 Timed Average Power Result = Reading + Cable Loss + Atten. Loss
 Cable Loss and Atten. Loss. are included in Power Meter Reading value.

The test was performed with condition that obtained the maximum timed-average power for comparing power of Tune-up upper limit.

Average Output Power
(Reference data for RF Exposure)

Test place : Ise EMC Lab. No.7 Shielded Room
Report No. : 11232804H
Date : April 22, 2016
Temperature / Humidity : 22deg. C / 61 % RH
Engineer : Yutaka Yoshida
Mode : Tx 11n-20 MCS8(Long)

Antenna A+B Timed Average Applied limit: 15.407, mobile and portable client device

Tested Frequency [MHz]	26 dB EBW (B for FCC) [MHz]	99% OBW (B for IC) [MHz]	Timed Average Power						e.i.r.p.					
			Antenna			Result	Limit	Margin	Antenna			Result	Limit	Margin
			A [mW]	B [mW]	Sum [mW]	[dBm]	[dBm]	[dB]	A [mW]	B [mW]	Sum [mW]	[dBm]	[dBm]	[dB]
5745	-	-	14.62	14.72	29.34	14.68	30.00	15.32	25.82	26.00	51.82	17.15	36.00	18.85
5785	-	-	14.39	14.19	28.58	14.56	30.00	15.44	25.41	25.06	50.47	17.03	36.00	18.97
5825	-	-	14.32	14.26	28.58	14.56	30.00	15.44	25.29	25.18	50.47	17.03	36.00	18.97

Antenna A							Antenna B						
Tested Frequency [MHz]	Duty Factor [dB]	Power Meter Reading [dBm]	Cable Loss [dB]	Atten. Loss [dB]	Antenna Gain [dBi]	Result		Power Meter Reading [dBm]	Cable Loss [dB]	Atten. Loss [dB]	Antenna Gain [dBi]	Result	
						Cond. Power [dBm]	e.i.r.p. [dBm]					Cond. Power [dBm]	e.i.r.p. [dBm]
5745	0.00	11.65	0.00	0.00	2.47	11.65	14.12	11.68	0.00	0.00	2.47	11.68	14.15
5785	0.00	11.58	0.00	0.00	2.47	11.58	14.05	11.52	0.00	0.00	2.47	11.52	13.99
5825	0.00	11.56	0.00	0.00	2.47	11.56	14.03	11.54	0.00	0.00	2.47	11.54	14.01

Sample Calculation:

Cable Loss and Atten. Loss are included in Power Meter Reading value.

e.i.r.p. Result = Conducted Power Result + Antenna Gain

Antenna directional Gain = $G_{ANT\ MAX} + 10 \log(N_{ANT} / N_{SS})$

The test was performed with condition that obtained the maximum timed-average power for comparing power of Tune-up upper limit.

Average Output Power
(Reference data for RF Exposure)

Test place : Ise EMC Lab. No.7 Shielded Room
 Report No. : 11232804H
 Date : April 22, 2016
 Temperature / Humidity : 22deg. C / 61 % RH
 Engineer : Yutaka Yoshida
 Mode : Tx 11n-40 MCS0(Long)

Antenna A Timed Average

Tested Frequency [MHz]	Power Meter Reading [dBm]	Cable Loss [dB]	Atten. Loss [dB]	Timed Average Power			
				Result		Limit	Margin
				[dBm]	[mW]	[dBm]	[dB]
5755	14.81	0.00	0.00	14.81	30.27	30.00	15.19
5795	14.99	0.00	0.00	14.99	31.55	30.00	15.01

Sample Calculation:
 Timed Average Power Result = Reading + Cable Loss + Atten. Loss
 Cable Loss and Atten. Loss. are included in Power Meter Reading value.

Antenna B Timed Average

Tested Frequency [MHz]	Power Meter Reading [dBm]	Cable Loss [dB]	Atten. Loss [dB]	Timed Average Power			
				Result		Limit	Margin
				[dBm]	[mW]	[dBm]	[dB]
5755	14.93	0.00	0.00	14.93	31.12	30.00	15.07
5795	14.51	0.00	0.00	14.51	28.25	30.00	15.49

Sample Calculation:
 Timed Average Power Result = Reading + Cable Loss + Atten. Loss
 Cable Loss and Atten. Loss. are included in Power Meter Reading value.

The test was performed with condition that obtained the maximum timed-average power for comparing power of Tune-up upper limit.

Average Output Power
(Reference data for RF Exposure)

Test place : Ise EMC Lab. No.7 Shielded Room
Report No. : 11232804H
Date : April 22, 2016
Temperature / Humidity : 22deg. C / 61 % RH
Engineer : Yutaka Yoshida
Mode : Tx 11n-40 MCS8(Long)

Antenna A+B Timed Average Applied limit: 15.407, mobile and portable client device

Tested Frequency [MHz]	26 dB EBW (B for FCC) [MHz]	99% OBW (B for IC) [MHz]	Timed Average Power						e.i.r.p.					
			A [mW]	B [mW]	Sum [mW]	Result [dBm]	Limit [dBm]	Margin [dB]	A [mW]	B [mW]	Sum [mW]	Result [dBm]	Limit [dBm]	Margin [dB]
5755	-	-	15.45	15.42	30.87	14.90	30.00	15.10	27.29	27.23	54.52	17.37	36.00	18.63
5795	-	-	15.07	14.76	29.82	14.75	30.00	15.25	26.61	26.06	52.67	17.22	36.00	18.78

Antenna A							Antenna B						
Tested Frequency [MHz]	Duty Factor [dB]	Power Meter Reading [dBm]	Cable Loss [dB]	Atten. Loss [dB]	Antenna Gain [dBi]	Result		Power Meter Reading [dBm]	Cable Loss [dB]	Atten. Loss [dB]	Antenna Gain [dBi]	Result	
						Cond. Power [dBm]	e.i.r.p. [dBm]					Cond. Power [dBm]	e.i.r.p. [dBm]
5755	0.00	11.89	0.00	0.00	2.47	11.89	14.36	11.88	0.00	0.00	2.47	11.88	14.35
5795	0.00	11.78	0.00	0.00	2.47	11.78	14.25	11.69	0.00	0.00	2.47	11.69	14.16

Sample Calculation:

Cable Loss and Atten. Loss are included in Power Meter Reading value.

e.i.r.p. Result = Conducted Power Result + Antenna Gain

Antenna directional Gain = $G_{ANT\ MAX} + 10 \log(N_{ANT} / N_{SS})$

The test was performed with condition that obtained the maximum timed-average power for comparing power of Tune-up upper limit.

Burst rate confirmation

Test place	Ise EMC Lab. No.7 Shielded Room
Report No.	11232804H
Date	April 22, 2016
Temperature / Humidity	22deg. C / 61 % RH
Engineer	Yutaka Yoshida
Mode	Tx

11a 6Mbps

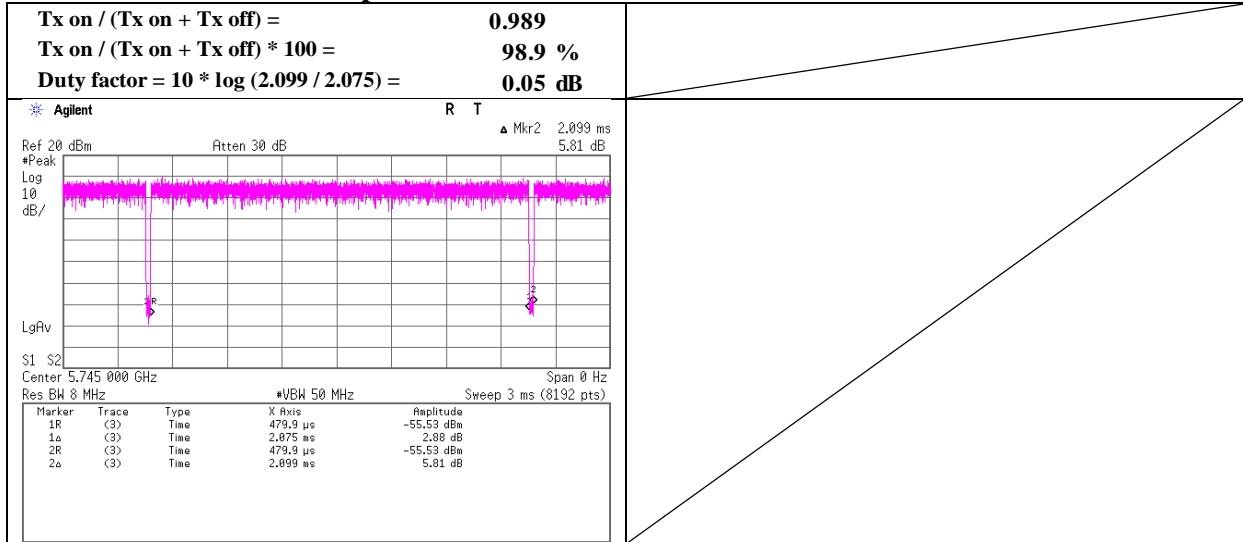

11n-20 MCS15(Long)

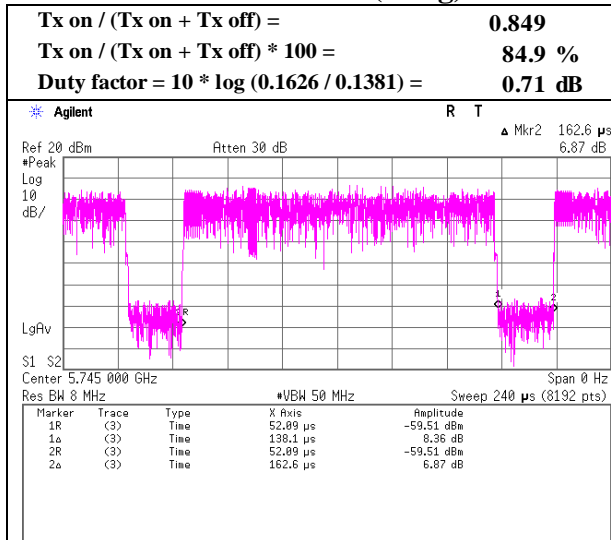

11n-40 MCS15(Long)

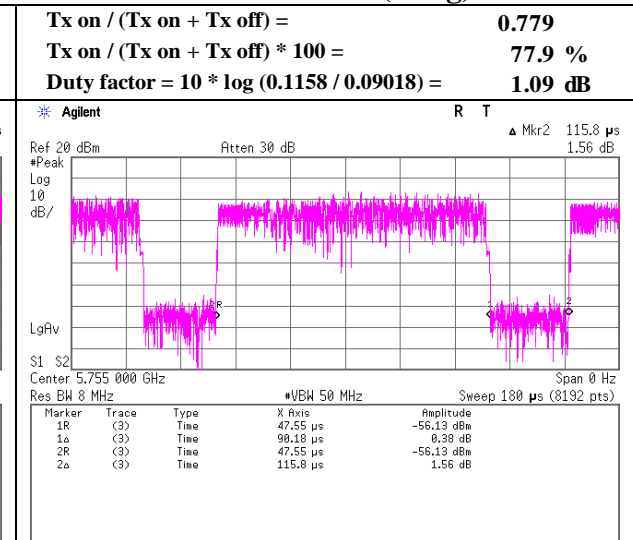

Maximum Power Spectral Density

Test place : Ise EMC Lab. No.7 Shielded Room
 Report No. : 11232804H
 Date : April 22, 2016
 Temperature / Humidity : 22deg. C / 61 % RH
 Engineer : Yutaka Yoshida
 Mode : Tx 11a 6Mbps

Antenna A

Applied limit: 15.407, mobile and portable client device

Tested Frequency [MHz]	PSD Reading [dBm /MHz]	Cable Loss [dB]	Atten. Loss [dB]	Duty Factor [dB]	Antenna Gain [dBi]	RBW Correction Factor [dB]	PSD (Conducted)			PSD (e.i.r.p.)		
							Result [dBm /MHz]	Limit [dBm /MHz]	Margin [dB]	Result [dBm /MHz]	Limit [dBm /MHz]	Margin [dB]
5745	-10.12	0.89	9.85	0.05	2.47	0.27	0.94	30.00	29.06	3.41	36.00	32.59
5785	-10.21	0.90	9.85	0.05	2.47	0.27	0.86	30.00	29.14	3.33	36.00	32.67
5825	-10.20	0.90	9.85	0.05	2.47	0.27	0.87	30.00	29.13	3.34	36.00	32.66

Sample Calculation:

PSD: Power Spectral Density

The PSD within 5725 MHz to 5825 MHz are based on any 500 kHz band.

RBW Correction Factor = $10 * \log(\text{Specified bandwidth} / \text{Measured bandwidth})$

PSD Result (Conducted) = Reading + Cable Loss + Atten. Loss + Duty Factor + RBW Correction Factor

PSD Result (e.i.r.p.) = Conducted PSD Result + Antenna Gain

Antenna B

Applied limit: 15.407, mobile and portable client device

Tested Frequency [MHz]	PSD Reading [dBm /MHz]	Cable Loss [dB]	Atten. Loss [dB]	Duty Factor [dB]	Antenna Gain [dBi]	RBW Correction Factor [dB]	PSD (Conducted)			PSD (e.i.r.p.)		
							Result [dBm /MHz]	Limit [dBm /MHz]	Margin [dB]	Result [dBm /MHz]	Limit [dBm /MHz]	Margin [dB]
5745	-10.03	0.89	9.85	0.05	2.07	0.27	1.03	30.00	28.97	3.10	36.00	32.90
5785	-10.00	0.90	9.85	0.05	2.07	0.27	1.07	30.00	28.93	3.14	36.00	32.86
5825	-10.00	0.90	9.85	0.05	2.07	0.27	1.07	30.00	28.93	3.14	36.00	32.86

Sample Calculation:

PSD: Power Spectral Density

The PSD within 5725 MHz to 5825 MHz are based on any 500 kHz band.

RBW Correction Factor = $10 * \log(\text{Specified bandwidth} / \text{Measured bandwidth})$

PSD Result (Conducted) = Reading + Cable Loss + Atten. Loss + Duty Factor + RBW Correction Factor

PSD Result (e.i.r.p.) = Conducted PSD Result + Antenna Gain

Maximum Power Spectral Density

Test place : Ise EMC Lab. No.7 Shielded Room
 Report No. : 11232804H
 Date : April 22, 2016
 Temperature / Humidity : 22deg. C / 61 % RH
 Engineer : Yutaka Yoshida
 Mode : Tx 11n-20 MCS15(Long)

Applied limit: 15.407, mobile and portable client device

Tested Frequency [MHz]	PSD (Conducted)						PSD (e.i.r.p.)					
	Antenna			Result	Limit	Margin	Antenna			Result	Limit	Margin
	A	B	Sum				A	B	Sum			
5745	0.90	0.86	1.76	2.46	30.00	27.54	1.59	1.52	3.11	4.93	36.00	31.07
5785	0.92	0.93	1.85	2.67	30.00	27.33	1.63	1.63	3.27	5.14	36.00	30.86
5825	0.94	0.91	1.84	2.65	30.00	27.35	1.65	1.60	3.25	5.12	36.00	30.88

Tested Frequency [MHz]	Duty Factor [dB]	RBW Correction Factor [dB]	Antenna A				Antenna B				PSD Result			
			PSD Reading	Cable Loss	Atten. Loss	Antenna Gain	PSD Reading	Cable Loss	Atten. Loss	Antenna Gain	Cond.	e.i.r.p.	Cond.	e.i.r.p.
5745	0.71	0.27	-12.17	0.89	9.85	2.47	-0.45	2.02	-12.25	0.92	9.70	2.47	-0.65	1.82
5785	0.71	0.27	-12.07	0.90	9.85	2.47	-0.34	2.13	-11.95	0.93	9.70	2.47	-0.34	2.13
5825	0.71	0.27	-12.02	0.90	9.85	2.47	-0.29	2.18	-12.03	0.93	9.70	2.47	-0.43	2.04

Sample Calculation:

PSD: Power Spectral Density

The PSD within 5725 MHz to 5825 MHz are based on any 500 kHz band.

RBW Correction Factor = $10 * \log(\text{Specified bandwidth} / \text{Measured bandwidth})$

PSD Result (Conducted) = Reading + Cable Loss + Atten. Loss + Duty Factor + RBW Correction Factor

PSD Result (e.i.r.p.) = Conducted PSD Result + Antenna Gain

Antenna directional Gain = $G_{ANT\ MAX} + 10 \log(N_{ANT} / N_{SS})$

Maximum Power Spectral Density

Test place : Ise EMC Lab. No.7 Shielded Room
 Report No. : 11232804H
 Date : April 22, 2016
 Temperature / Humidity : 22deg. C / 61 % RH
 Engineer : Yutaka Yoshida
 Mode : Tx 11n-40 MCS15(Long)

Applied limit: 15.407, mobile and portable client device

Tested Frequency [MHz]	PSD (Conducted)						PSD (e.i.r.p.)					
	Antenna			Result [dBm/MHz]	Limit [dBm/MHz]	Margin [dB]	Antenna			Result [dBm/MHz]	Limit [dBm/MHz]	Margin [dB]
	A [mW/MHz]	B [mW/MHz]	Sum [mW/MHz]				A [mW/MHz]	B [mW/MHz]	Sum [mW/MHz]			
5755	0.66	0.68	1.33	1.25	30.00	28.75	1.16	1.20	2.36	3.72	36.00	32.28
5795	0.63	0.62	1.25	0.97	30.00	29.03	1.12	1.09	2.21	3.44	36.00	32.56

Tested Frequency [MHz]	Duty Factor [dB]	RBW Correction Factor [dB]	Antenna A					Antenna B						
			PSD Reading [dBm/MHz]	Cable Loss [dB]	Atten. Loss [dB]	Antenna Gain [dBi]	PSD Result Cond. [dBm/MHz]	e.i.r.p. [dBm/MHz]	PSD Reading [dBm/MHz]	Cable Loss [dB]	Atten. Loss [dB]	Antenna Gain [dBi]	PSD Result Cond. [dBm/MHz]	e.i.r.p. [dBm/MHz]
			5755	1.09	0.27	-13.93	0.89	9.85	2.47	-1.83	0.64	-13.67	0.92	9.70
5795	1.09	0.27	-14.10	0.90	9.85	2.47	-1.99	0.48	-14.08	0.93	9.70	2.47	-2.09	0.38

Sample Calculation:

PSD: Power Spectral Density

The PSD within 5725 MHz to 5825 MHz are based on any 500 kHz band.

RBW Correction Factor = $10 * \log(\text{Specified bandwidth} / \text{Measured bandwidth})$

PSD Result (Conducted) = Reading + Cable Loss + Atten. Loss + Duty Factor + RBW Correction Factor

PSD Result (e.i.r.p.) = Conducted PSD Result + Antenna Gain

Antenna directional Gain = $G_{\text{ANT MAX}} + 10 \log(N_{\text{ANT}} / N_{\text{SS}})$

Maximum Power Spectral Density

Test place	Ise EMC Lab. No.7 Shielded Room
Report No.	11232804H
Date	April 22, 2016
Temperature / Humidity	22deg. C / 61 % RH
Engineer	Yutaka Yoshida
Mode	Tx 11a 6Mbps

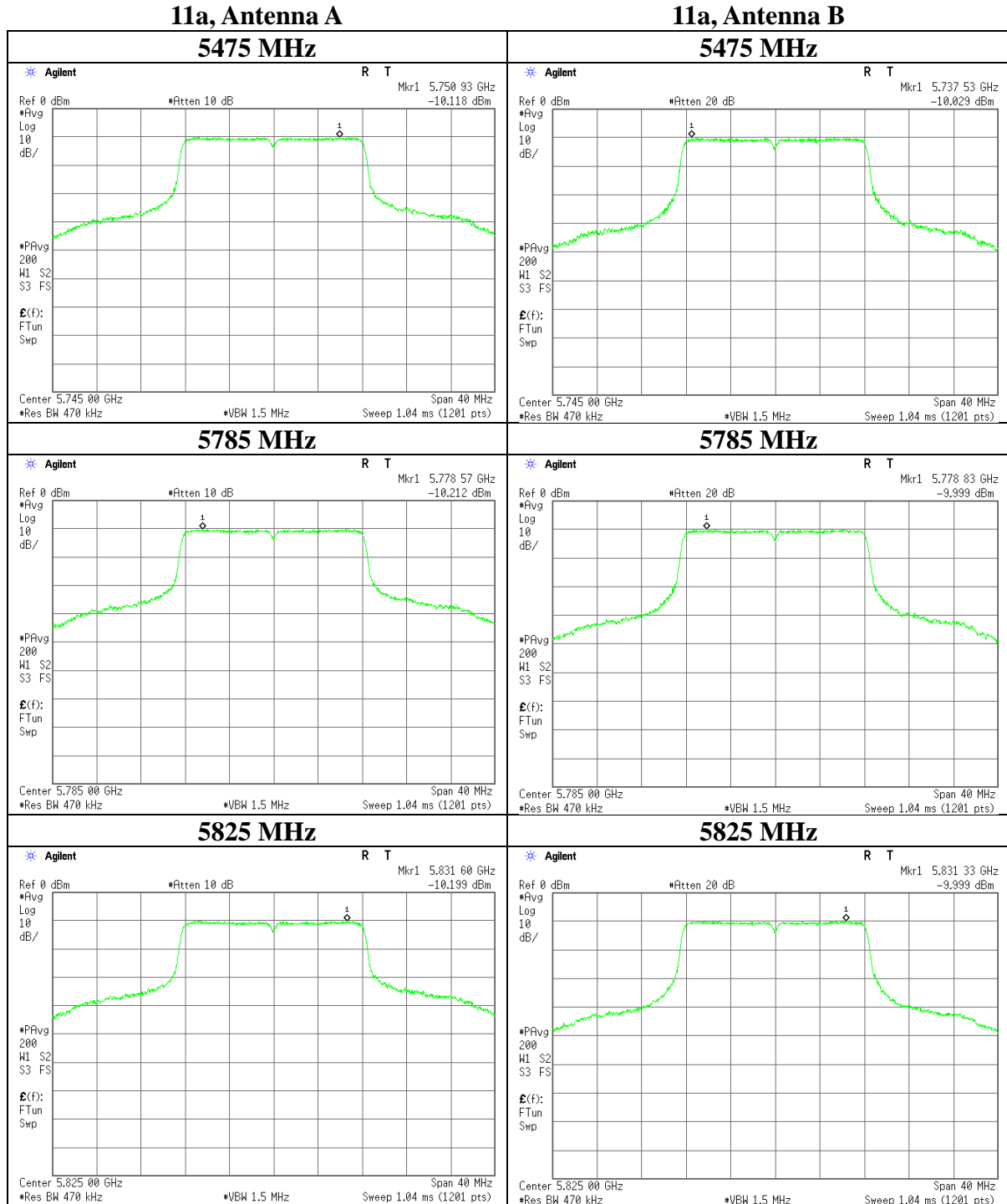

UL Japan, Inc.

Ise EMC Lab.

4383-326 Asama-cho, Ise-shi, Mie-ken 516-0021 JAPAN

Telephone : +81 596 24 8999

Facsimile : +81 596 24 8124

Maximum Power Spectral Density

Test place	Ise EMC Lab. No.7 Shielded Room
Report No.	11232804H
Date	April 22, 2016
Temperature / Humidity	22deg. C / 61 % RH
Engineer	Yutaka Yoshida
Mode	Tx 11n-20 MCS15(Long)

11n-20, Antenna A

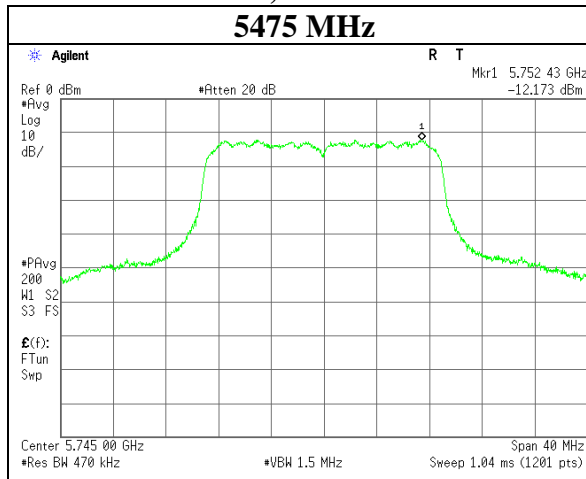

11n-20, Antenna B

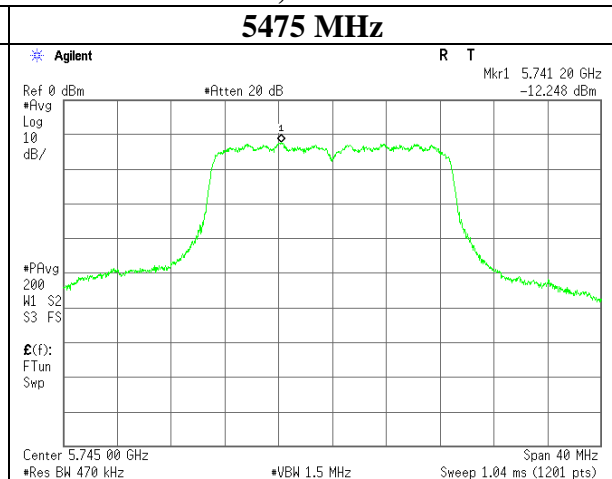

5785 MHz

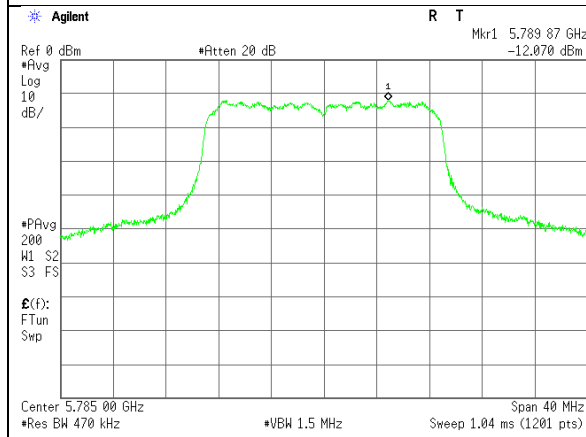

5785 MHz

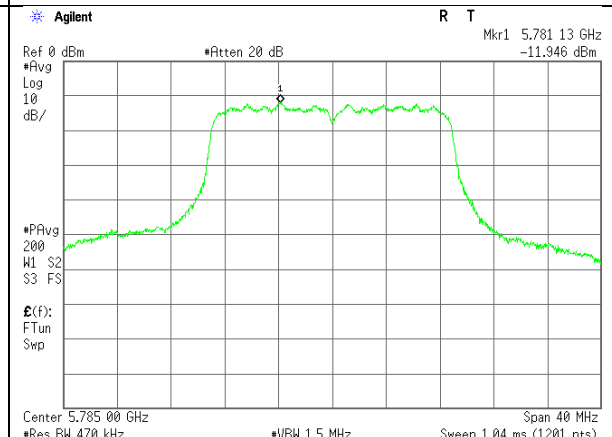

5825 MHz

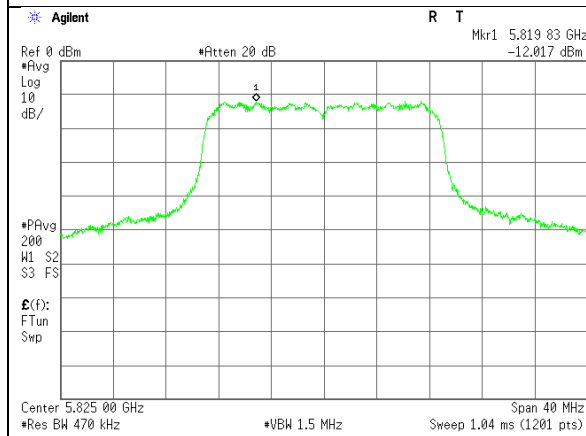

5825 MHz

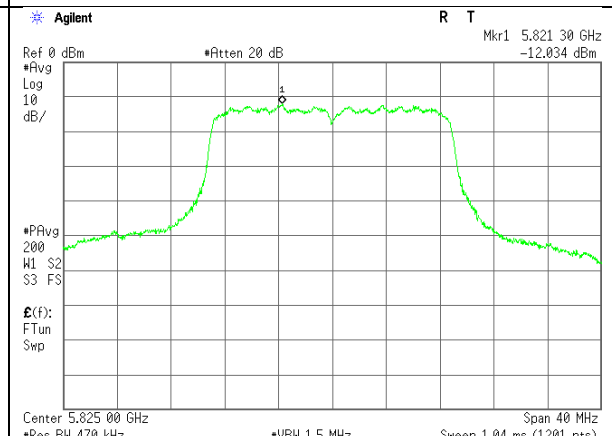

UL Japan, Inc.

Ise EMC Lab.

4383-326 Asama-cho, Ise-shi, Mie-ken 516-0021 JAPAN

Telephone : +81 596 24 8999

Facsimile : +81 596 24 8124

Maximum Power Spectral Density

Test place	Ise EMC Lab. No.7 Shielded Room
Report No.	11232804H
Date	April 22, 2016
Temperature / Humidity	22deg. C / 61 % RH
Engineer	Yutaka Yoshida
Mode	Tx 11n-40 MCS15(Long)

11n-40, Antenna A

11n-40, Antenna B

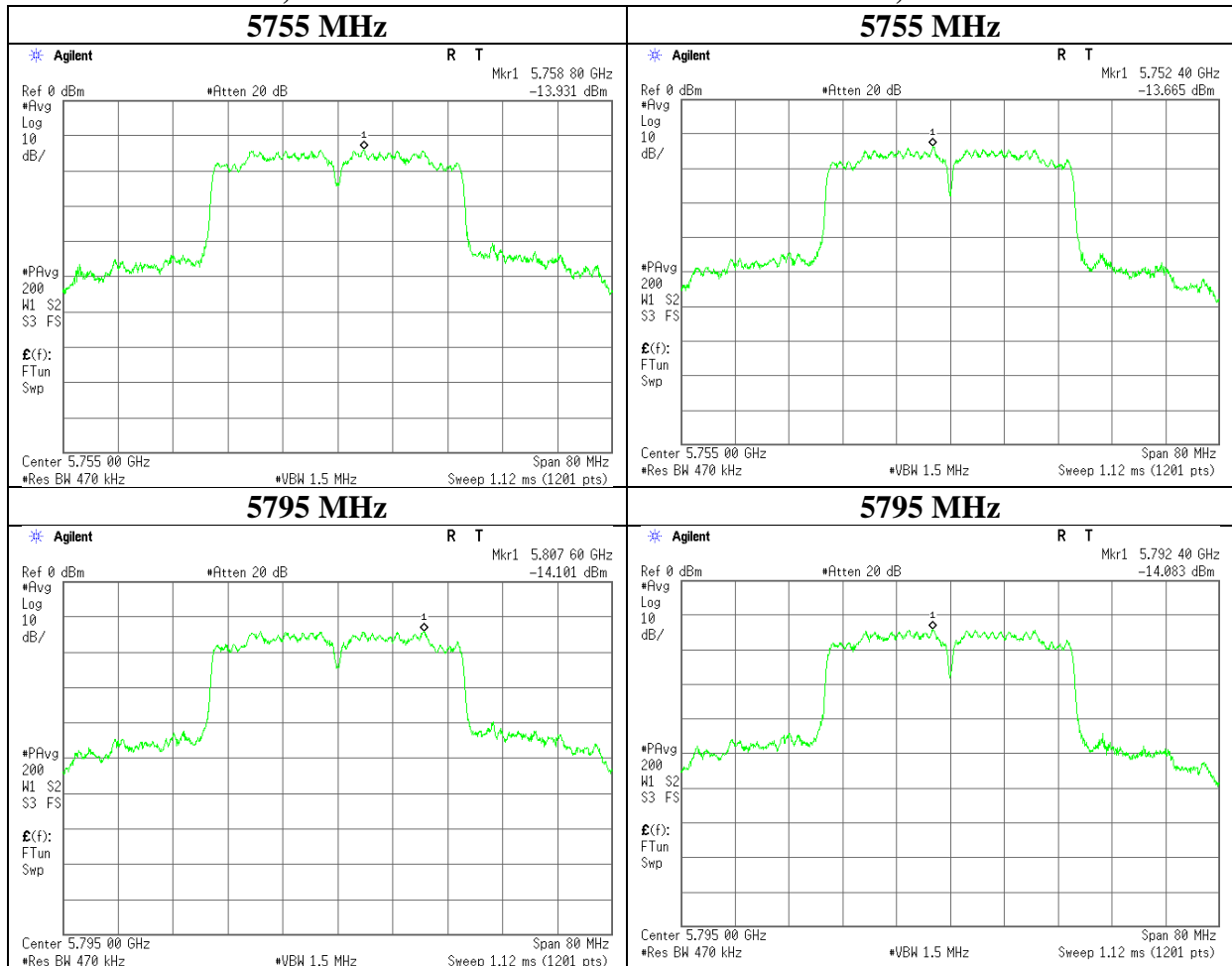

UL Japan, Inc.

Ise EMC Lab.

4383-326 Asama-cho, Ise-shi, Mie-ken 516-0021 JAPAN

Telephone : +81 596 24 8999

Facsimile : +81 596 24 8124

APPENDIX 2: Test instruments

Test equipment

Control No.	Instrument	Manufacturer	Model No	Serial No	Test Item	Calibration Date * Interval(month)
MPM-16	Power Meter	Agilent	8990B	MY51000271	AT	2016/04/07 * 12
MPSE-22	Power sensor	Agilent	N1923A	MY54070003	AT	2016/04/07 * 12
MAT-89	Attenuator	Weinschel Associates	WA56-10	56100305	AT	2015/06/01 * 12
MCC-207	Microwave Cable	RS Components	R-132G7210200 CD	-	AT	2016/02/08 * 12
MPSE-23	Power sensor	Agilent	N1923A	MY54070004	AT	2016/04/07 * 12
MAT-90	Attenuator	Weinschel Associates	WA56-10	56100306	AT	2015/06/01 * 12
MCC-208	Microwave Cable	RS Components	R-132G7210200 CD	-	AT	2016/02/08 * 12
MRENT-126	Spectrum Analyzer	KEYSIGHT	E4440A	MY46185516	AT	2015/07/31 * 12
MOS-29	Thermo-Hygrometer	Custom	CTH-201	2901	AT	2016/01/21 * 12
MOS-34	Thermo-Hygrometer	Custom	CTH-201	3401	AT	2016/01/21 * 12
MAEC-03	Semi Anechoic Chamber(NSA)	TDK	Semi Anechoic Chamber 3m	DA-10005	CE	2015/10/01 * 12
MOS-13	Thermo-Hygrometer	Custom	CTH-180	1301	CE	2016/01/21 * 12
MJM-16	Measure	KOMELON	KMC-36	-	CE	-
MSA-10	Spectrum Analyzer	Agilent	E4448A	MY46180655	CE	2016/02/24 * 12
MMM-08	DIGITAL HiTESTER	Hioki	3805	051201197	CE	2016/01/13 * 12
MTR-08	Test Receiver	Rohde & Schwarz	ESCI	100767	CE	2015/09/02 * 12
MLS-23	LISN(AMN)	Schwarzbeck	NSLK8127	8127-729	CE(EUT)	2015/07/10 * 12
MCC-112	Coaxial cable	Fujikura/Suhner/TSJ	5D-2W(10m)/SF M141(3m)/sucof orm141-PE(1m)/ 421-010(1.5m)/ RFM-E321(Swit cher)	-/00640	CE	2015/07/02 * 12
MAT-66	Attenuator(13dB)	JFW Industries, Inc.	50FP-013H2 N	-	CE	2016/01/14 * 12
MTA-28	Terminator	TME	CT-01	-	CE	2015/11/12 * 12

The expiration date of the calibration is the end of the expired month.

All equipment is calibrated with valid calibrations. Each measurement data is traceable to the national or international standards.

As for some calibrations performed after the tested dates, those test equipment have been controlled by means of an unbroken chains of calibrations.

Test Item: **CE: Conducted Emission**
 AT: Antenna Terminal Conducted test