

## 20130103 SystemPerformanceCheck-D5GHzV2 SN 1138

Frequency: 5200 MHz; Duty Cycle: 1:1; Room Ambient Temperature: 25.0°C; Liquid Temperature: 24.0°C

Medium parameters used:  $f = 5200$  MHz;  $\sigma = 5.364$  mho/m;  $\epsilon_r = 47.126$ ;  $\rho = 1000$  kg/m<sup>3</sup>

DASY5 Configuration:

- Area Scan Setting: Find Secondary Maximum Within: 2.0 dB and with a peak SAR value greater than 0.0012W/kg
- Electronics: DAE4 Sn1259; Calibrated: 2/13/2012
- Probe: EX3DV4 - SN3686; ConvF(4.04, 4.04, 4.04); Calibrated: 2/16/2012;
- Sensor-Surface: 1.4mm (Mechanical Surface Detection)
- Phantom: SAM; Type: QD000P40CD; Serial: 1629

**Body/5.2 GHz, Pin=100mW/Area Scan (61x61x1):** Interpolated grid: dx=1.000 mm, dy=1.000 mm

Reference Value = 49.583 V/m; Power Drift = 0.15 dB

**Fast SAR: SAR(1 g) = 7.02 W/kg; SAR(10 g) = 2.01 W/kg**

Maximum value of SAR (interpolated) = 17.8 W/kg

**Body/5.2 GHz, Pin=100mW/Zoom Scan (8x8x7)/Cube 0:** Measurement grid: dx=4mm, dy=4mm, dz=1.4mm

Reference Value = 49.583 V/m; Power Drift = 0.15 dB

Peak SAR (extrapolated) = 30.6 W/kg

**SAR(1 g) = 7.78 W/kg; SAR(10 g) = 2.18 W/kg**

Maximum value of SAR (measured) = 18.7 W/kg

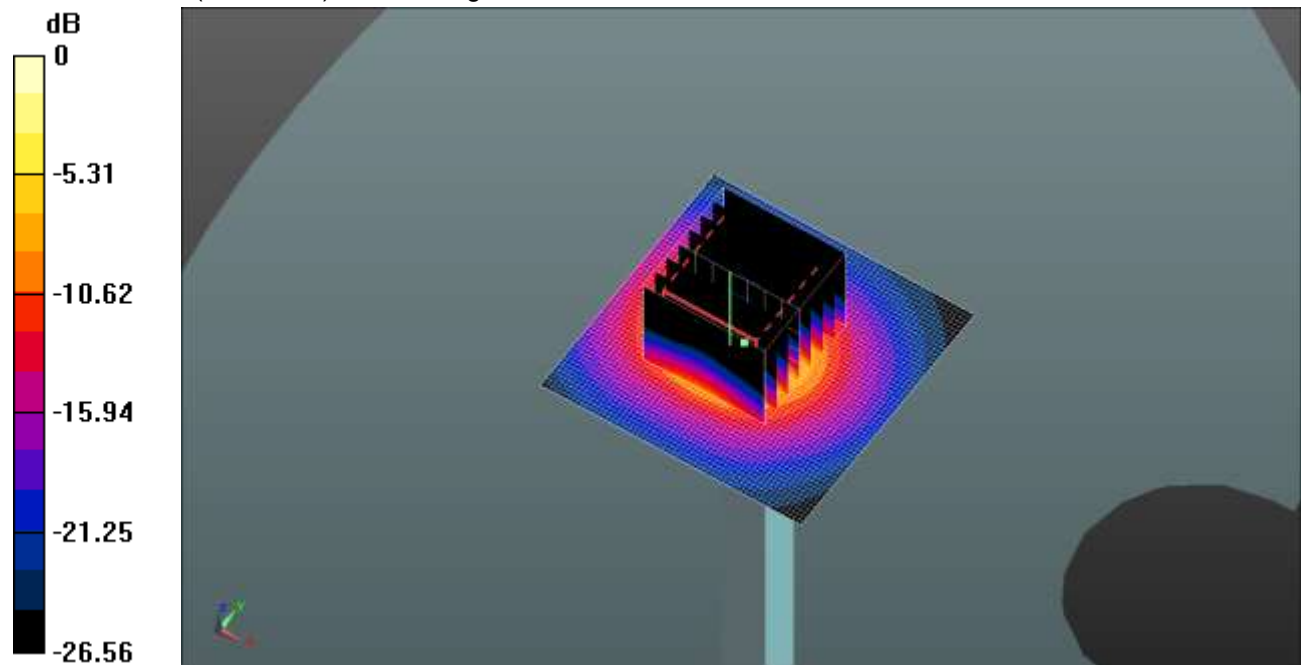

0 dB = 18.7 W/kg = 12.72 dBW/kg

## 20130103 SystemPerformanceCheck-D5GHzV2 SN 1138

Frequency: 5200 MHz; Duty Cycle: 1:1

**Body/5.2 GHz, Pin=100mW/Z Scan (1x1x21):** Measurement grid: dx=20mm, dy=20mm, dz=5mm  
Maximum value of SAR (measured) = 11.5 W/kg

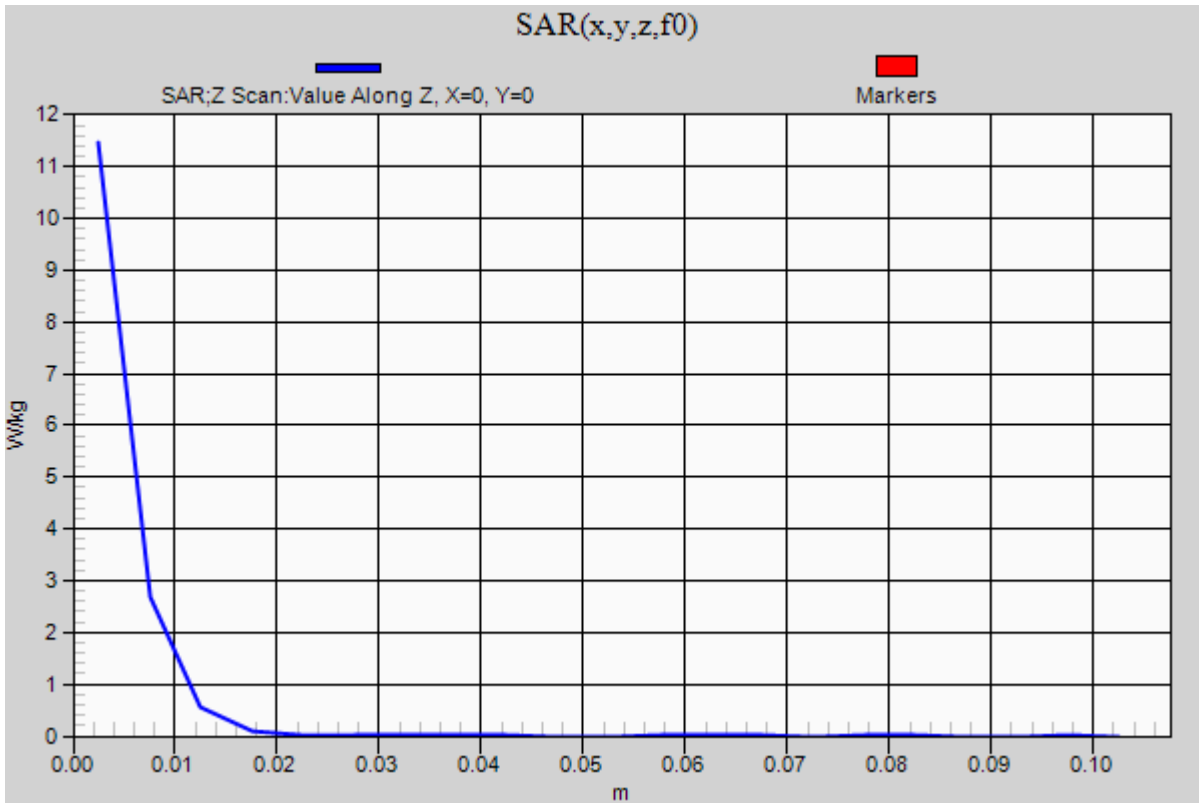

## 20130103 SystemPerformanceCheck-D5GHzV2 SN 1138

Frequency: 5600 MHz; Duty Cycle: 1:1; Room Ambient Temperature: 25.0°C; Liquid Temperature: 24.0°C  
Medium parameters used:  $f = 5600$  MHz;  $\sigma = 5.869$  mho/m;  $\epsilon_r = 46.496$ ;  $\rho = 1000$  kg/m<sup>3</sup>

DASY5 Configuration:

- Area Scan Setting: Find Secondary Maximum Within: 2.0 dB and with a peak SAR value greater than 0.0012W/kg
- Electronics: DAE4 Sn1259; Calibrated: 2/13/2012
- Probe: EX3DV4 - SN3686; ConvF(3.44, 3.44, 3.44); Calibrated: 2/16/2012;
- Sensor-Surface: 1.4mm (Mechanical Surface Detection)
- Phantom: SAM; Type: QD000P40CD; Serial: 1629

**Body/5.6 GHz, Pin=100mW 2/Area Scan (61x61x1):** Interpolated grid: dx=1.000 mm, dy=1.000 mm

Reference Value = 52.609 V/m; Power Drift = 0.05 dB

**Fast SAR: SAR(1 g) = 7.73 W/kg; SAR(10 g) = 2.1 W/kg**

Maximum value of SAR (interpolated) = 21.0 W/kg

**Body/5.6 GHz, Pin=100mW 2/Zoom Scan (8x8x7)/Cube 0:** Measurement grid: dx=4mm, dy=4mm, dz=1.4mm

Reference Value = 52.609 V/m; Power Drift = 0.05 dB

Peak SAR (extrapolated) = 35.4 W/kg

**SAR(1 g) = 8.34 W/kg; SAR(10 g) = 2.31 W/kg**

Maximum value of SAR (measured) = 20.5 W/kg

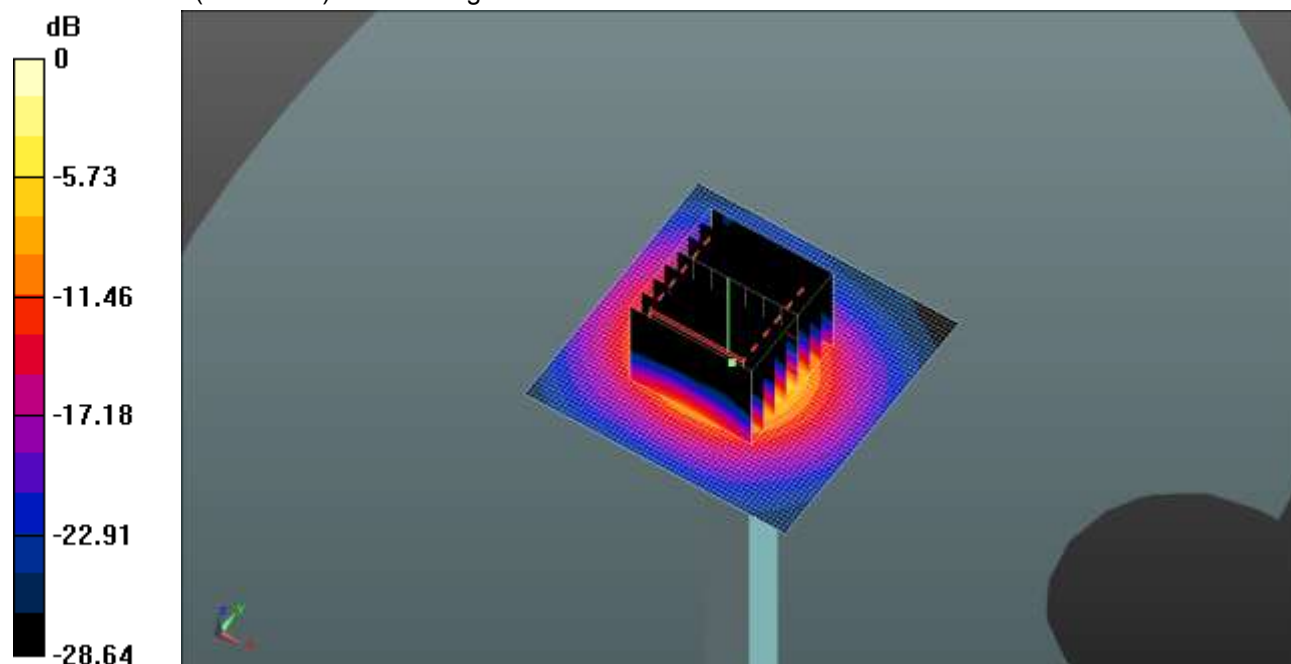

0 dB = 20.5 W/kg = 13.12 dBW/kg

## 20130103 SystemPerformanceCheck-D5GHzV2 SN 1138

Frequency: 5600 MHz; Duty Cycle: 1:1

**Body/5.6 GHz, Pin=100mW 2/Z Scan (1x1x21):** Measurement grid: dx=20mm, dy=20mm, dz=5mm  
Maximum value of SAR (measured) = 13.9 W/kg

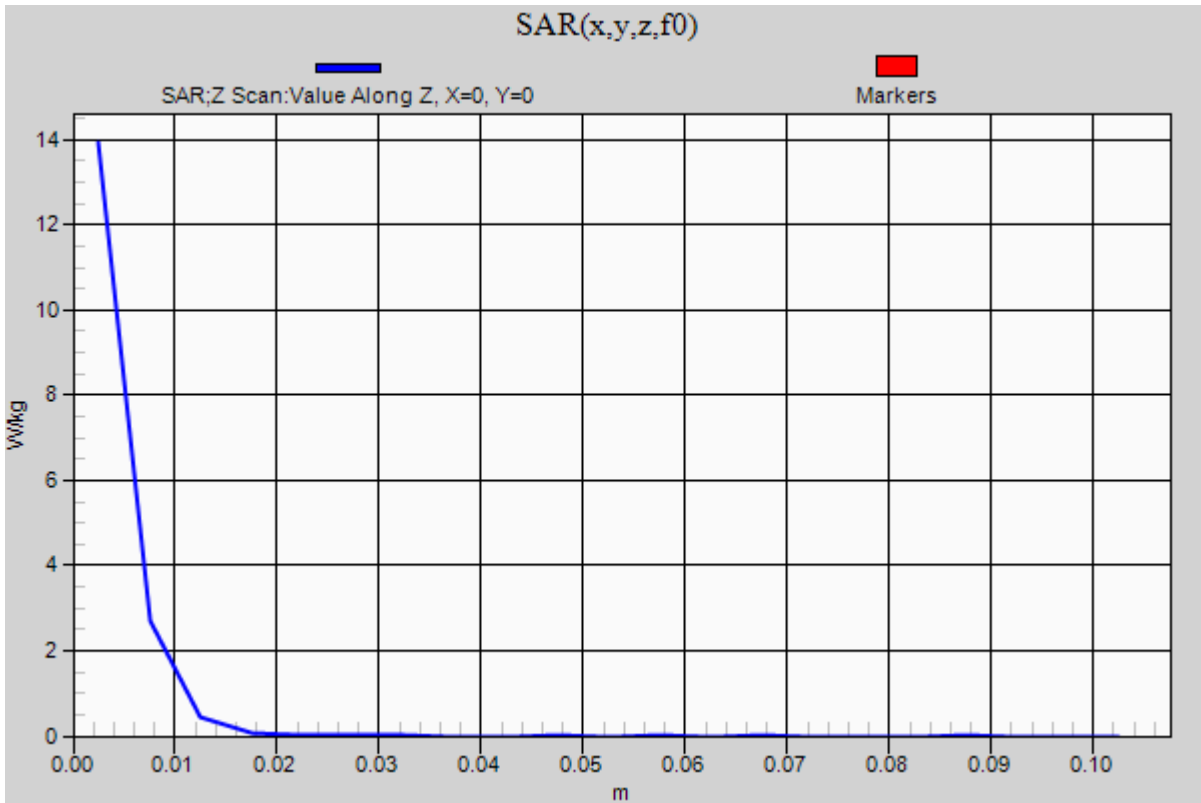

## 20130103 SystemPerformanceCheck-D5GHzV2 SN 1138

Frequency: 5800 MHz; Duty Cycle: 1:1; Room Ambient Temperature: 25.0°C; Liquid Temperature: 24.0°C  
Medium parameters used:  $f = 5800$  MHz;  $\sigma = 6.166$  mho/m;  $\epsilon_r = 46.353$ ;  $\rho = 1000$  kg/m<sup>3</sup>

DASY5 Configuration:

- Area Scan Setting: Find Secondary Maximum Within: 2.0 dB and with a peak SAR value greater than 0.0012W/kg
- Electronics: DAE4 Sn1259; Calibrated: 2/13/2012
- Probe: EX3DV4 - SN3686; ConvF(3.57, 3.57, 3.57); Calibrated: 2/16/2012;
- Sensor-Surface: 1.4mm (Mechanical Surface Detection)
- Phantom: SAM; Type: QD000P40CD; Serial: 1629

**Body/5.8 GHz, Pin=100mW/Area Scan (61x61x1):** Interpolated grid: dx=1.000 mm, dy=1.000 mm

Reference Value = 47.905 V/m; Power Drift = 0.12 dB

**Fast SAR: SAR(1 g) = 7.07 W/kg; SAR(10 g) = 1.97 W/kg**

Maximum value of SAR (interpolated) = 19.3 W/kg

**Body/5.8 GHz, Pin=100mW/Zoom Scan (8x8x7)/Cube 0:** Measurement grid: dx=4mm, dy=4mm, dz=1.4mm

Reference Value = 47.905 V/m; Power Drift = 0.12 dB

Peak SAR (extrapolated) = 33.8 W/kg

**SAR(1 g) = 7.89 W/kg; SAR(10 g) = 2.2 W/kg**

Maximum value of SAR (measured) = 19.2 W/kg

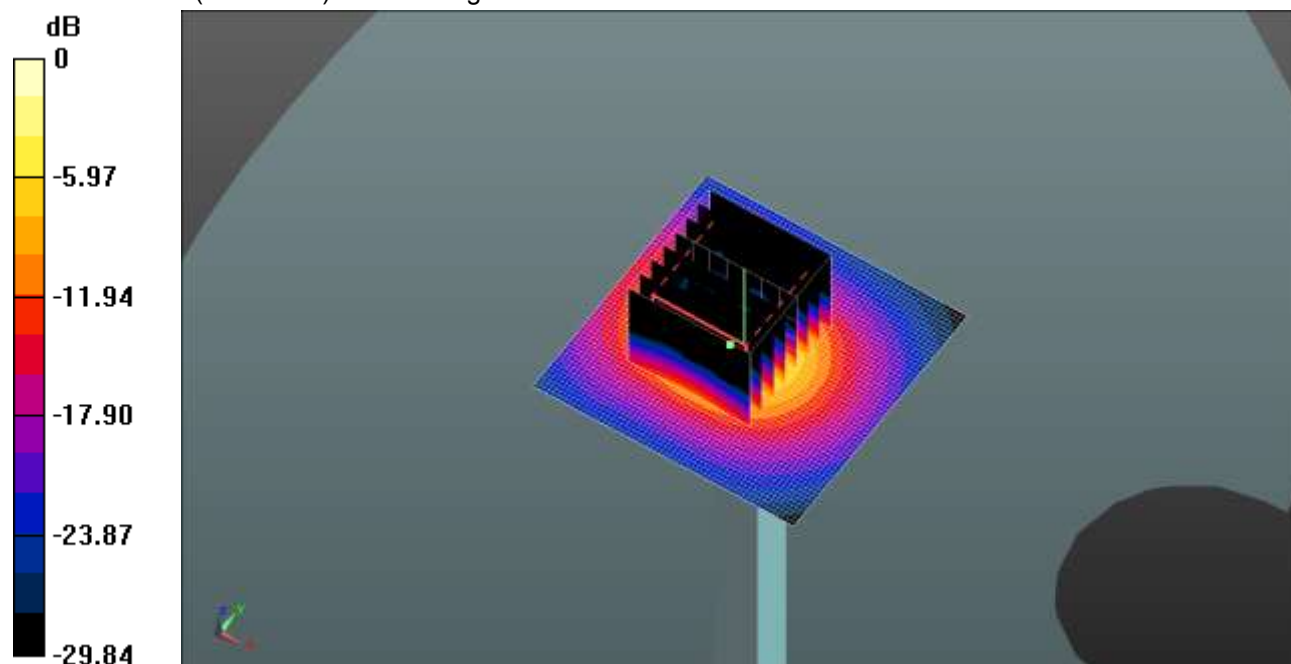

0 dB = 19.2 W/kg = 12.83 dBW/kg

## 20130103 SystemPerformanceCheck-D5GHzV2 SN 1138

Frequency: 5800 MHz; Duty Cycle: 1:1

**Body/5.8 GHz, Pin=100mW/Z Scan (1x1x21):** Measurement grid: dx=20mm, dy=20mm, dz=5mm  
Maximum value of SAR (measured) = 11.9 W/kg

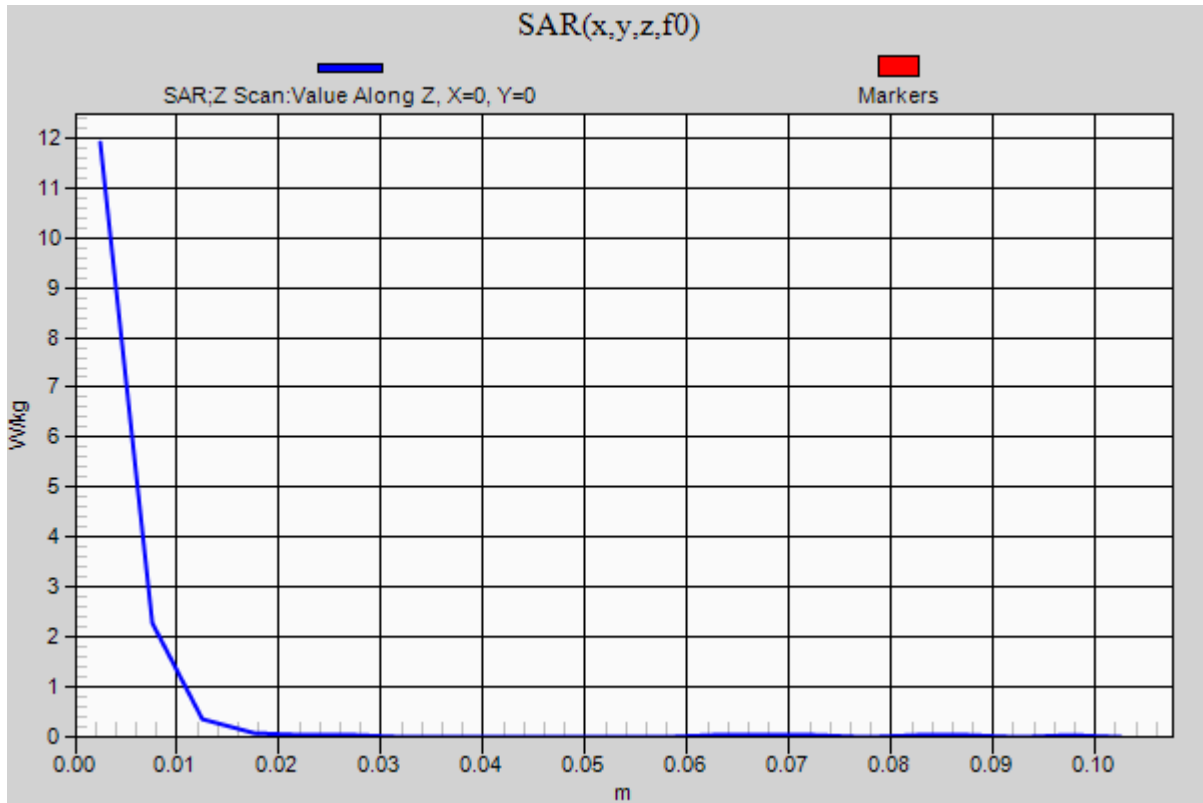

## 20130107 SystemPerformanceCheck-D5GHzV2 SN 1138

Frequency: 5200 MHz; Duty Cycle: 1:1; Room Ambient Temperature: 25.0°C; Liquid Temperature: 24.0°C  
Medium parameters used:  $f = 5200$  MHz;  $\sigma = 5.491$  mho/m;  $\epsilon_r = 48.12$ ;  $\rho = 1000$  kg/m<sup>3</sup>

DASY5 Configuration:

- Area Scan Setting: Find Secondary Maximum Within: 2.0 dB and with a peak SAR value greater than 0.0012W/kg
- Electronics: DAE4 Sn1259; Calibrated: 2/13/2012
- Probe: EX3DV4 - SN3686; ConvF(4.04, 4.04, 4.04); Calibrated: 2/16/2012;
- Sensor-Surface: 1.4mm (Mechanical Surface Detection)
- Phantom: SAM; Type: QD000P40CD; Serial: 1629

**Body/5.2 GHz, Pin=100mW 2/Area Scan (61x61x1):** Interpolated grid: dx=1.000 mm, dy=1.000 mm

Reference Value = 50.815 V/m; Power Drift = 0.06 dB

**Fast SAR: SAR(1 g) = 6.87 W/kg; SAR(10 g) = 1.93 W/kg**

Maximum value of SAR (interpolated) = 17.9 W/kg

**Body/5.2 GHz, Pin=100mW 2/Zoom Scan (8x8x7)/Cube 0:** Measurement grid: dx=4mm, dy=4mm, dz=1.4mm

Reference Value = 50.815 V/m; Power Drift = 0.06 dB

Peak SAR (extrapolated) = 28.7 W/kg

**SAR(1 g) = 7.44 W/kg; SAR(10 g) = 2.11 W/kg**

Maximum value of SAR (measured) = 17.7 W/kg

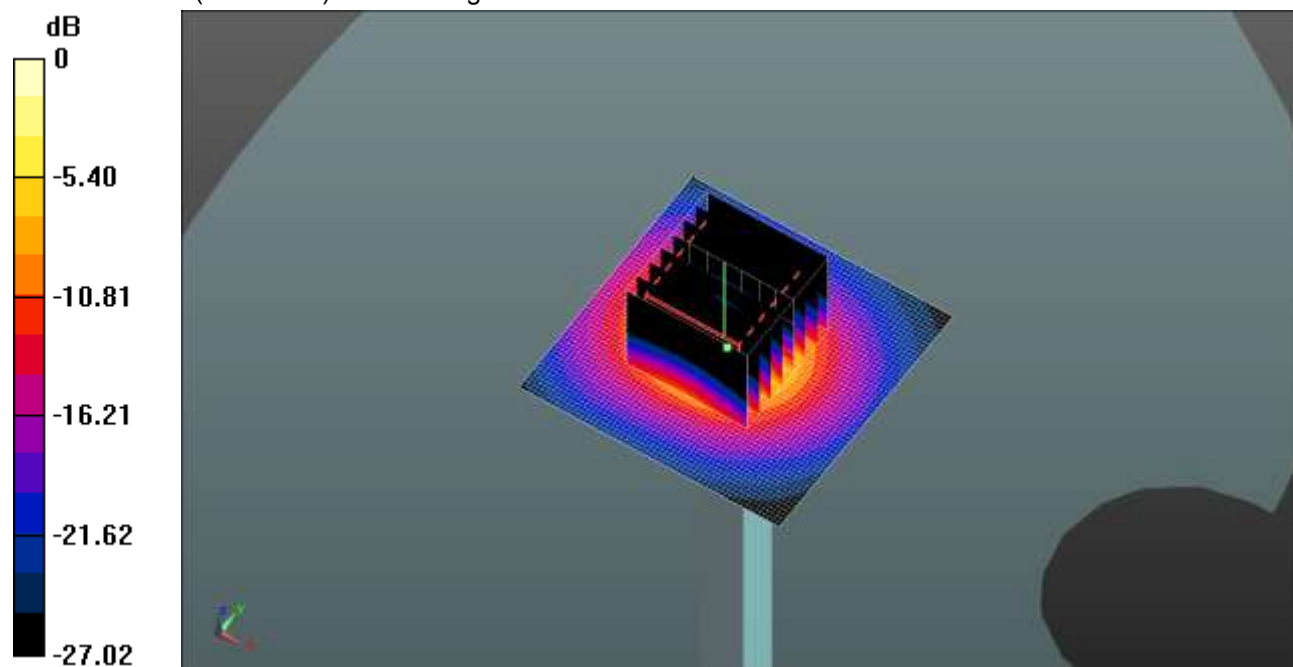

0 dB = 17.7 W/kg = 12.48 dBW/kg

## 20130107 SystemPerformanceCheck-D5GHzV2 SN 1138

Frequency: 5200 MHz; Duty Cycle: 1:1

**Body/5.2 GHz, Pin=100mW 2/Z Scan (1x1x21):** Measurement grid: dx=20mm, dy=20mm, dz=5mm  
Maximum value of SAR (measured) = 12.3 W/kg

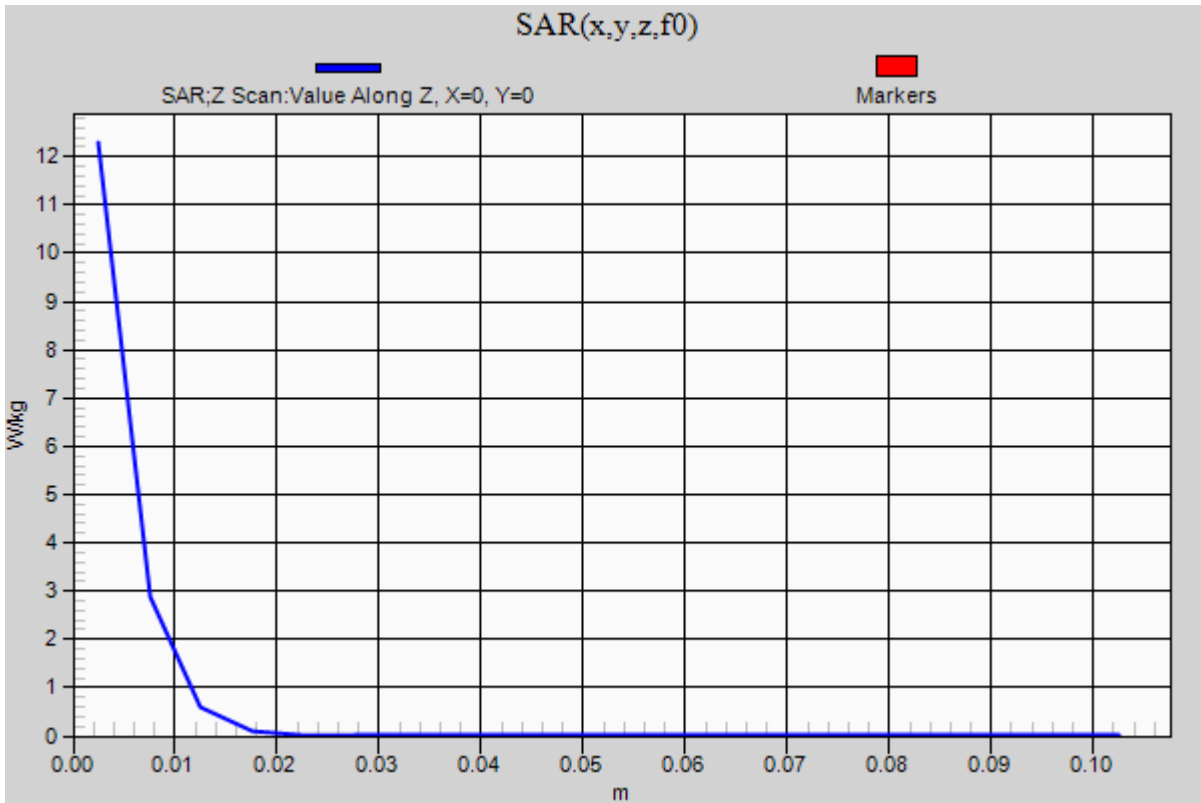

## 20130107 SystemPerformanceCheck-D5GHzV2 SN 1138

Frequency: 5600 MHz; Duty Cycle: 1:1; Room Ambient Temperature: 25.0°C; Liquid Temperature: 24.0°C  
Medium parameters used:  $f = 5600$  MHz;  $\sigma = 5.97$  mho/m;  $\epsilon_r = 47.501$ ;  $\rho = 1000$  kg/m<sup>3</sup>

DASY5 Configuration:

- Area Scan Setting: Find Secondary Maximum Within: 2.0 dB and with a peak SAR value greater than 0.0012W/kg
- Electronics: DAE4 Sn1259; Calibrated: 2/13/2012
- Probe: EX3DV4 - SN3686; ConvF(3.44, 3.44, 3.44); Calibrated: 2/16/2012;
- Sensor-Surface: 1.4mm (Mechanical Surface Detection)
- Phantom: SAM; Type: QD000P40CD; Serial: 1629

**Body/5.6 GHz, Pin=100mW 2/Area Scan (61x61x1):** Interpolated grid: dx=1.000 mm, dy=1.000 mm

Reference Value = 49.227 V/m; Power Drift = 0.11 dB

**Fast SAR: SAR(1 g) = 7.19 W/kg; SAR(10 g) = 2 W/kg**

Maximum value of SAR (interpolated) = 19.4 W/kg

**Body/5.6 GHz, Pin=100mW 2/Zoom Scan (8x8x7)/Cube 0:** Measurement grid: dx=4mm, dy=4mm, dz=1.4mm

Reference Value = 49.227 V/m; Power Drift = 0.11 dB

Peak SAR (extrapolated) = 33.1 W/kg

**SAR(1 g) = 7.87 W/kg; SAR(10 g) = 2.18 W/kg**

Maximum value of SAR (measured) = 19.0 W/kg

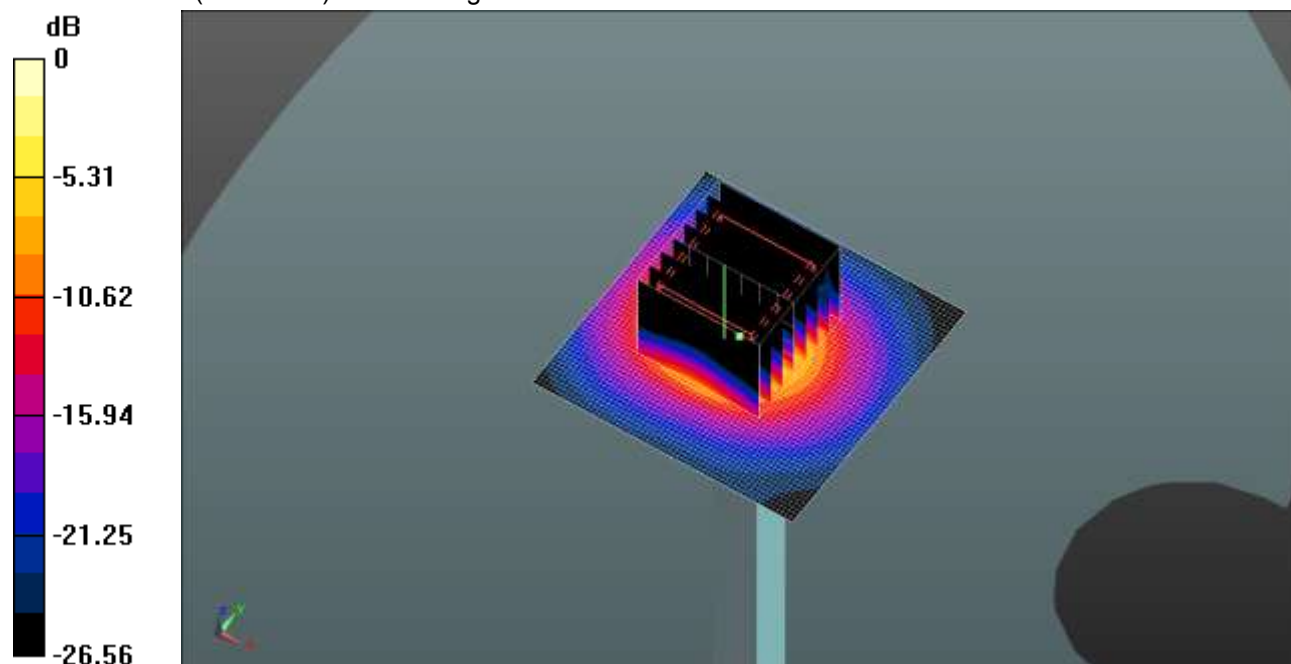

0 dB = 19.0 W/kg = 12.79 dBW/kg

## 20130107 SystemPerformanceCheck-D5GHzV2 SN 1138

Frequency: 5600 MHz; Duty Cycle: 1:1

**Body/5.6 GHz, Pin=100mW 2/Z Scan (1x1x21):** Measurement grid: dx=20mm, dy=20mm, dz=5mm  
Maximum value of SAR (measured) = 12.4 W/kg

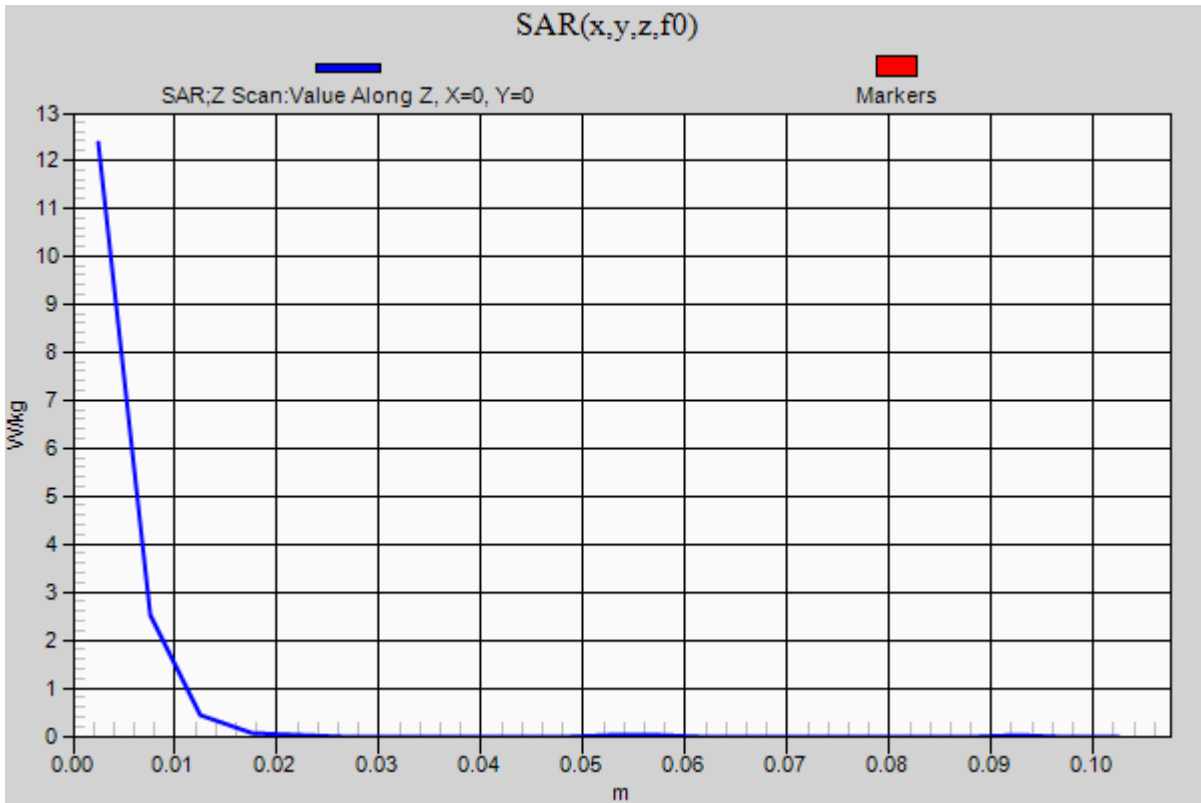

## 20130107 SystemPerformanceCheck-D5GHzV2 SN 1138

Frequency: 5800 MHz; Duty Cycle: 1:1; Room Ambient Temperature: 25.0°C; Liquid Temperature: 24.0°C  
Medium parameters used:  $f = 5800$  MHz;  $\sigma = 6.258$  mho/m;  $\epsilon_r = 47.293$ ;  $\rho = 1000$  kg/m<sup>3</sup>

DASY5 Configuration:

- Area Scan Setting: Find Secondary Maximum Within: 2.0 dB and with a peak SAR value greater than 0.0012W/kg
- Electronics: DAE4 Sn1259; Calibrated: 2/13/2012
- Probe: EX3DV4 - SN3686; ConvF(3.57, 3.57, 3.57); Calibrated: 2/16/2012;
- Sensor-Surface: 1.4mm (Mechanical Surface Detection)
- Phantom: SAM; Type: QD000P40CD; Serial: 1629

**Body/5.8 GHz, Pin=100mW/Area Scan (61x61x1):** Interpolated grid: dx=1.000 mm, dy=1.000 mm

Reference Value = 46.330 V/m; Power Drift = 0.10 dB

**Fast SAR: SAR(1 g) = 6.31 W/kg; SAR(10 g) = 1.76 W/kg**

Maximum value of SAR (interpolated) = 17.2 W/kg

**Body/5.8 GHz, Pin=100mW/Zoom Scan (8x8x7)/Cube 0:** Measurement grid: dx=4mm, dy=4mm, dz=1.4mm

Reference Value = 46.330 V/m; Power Drift = 0.10 dB

Peak SAR (extrapolated) = 30.0 W/kg

**SAR(1 g) = 7.09 W/kg; SAR(10 g) = 1.96 W/kg**

Maximum value of SAR (measured) = 17.9 W/kg

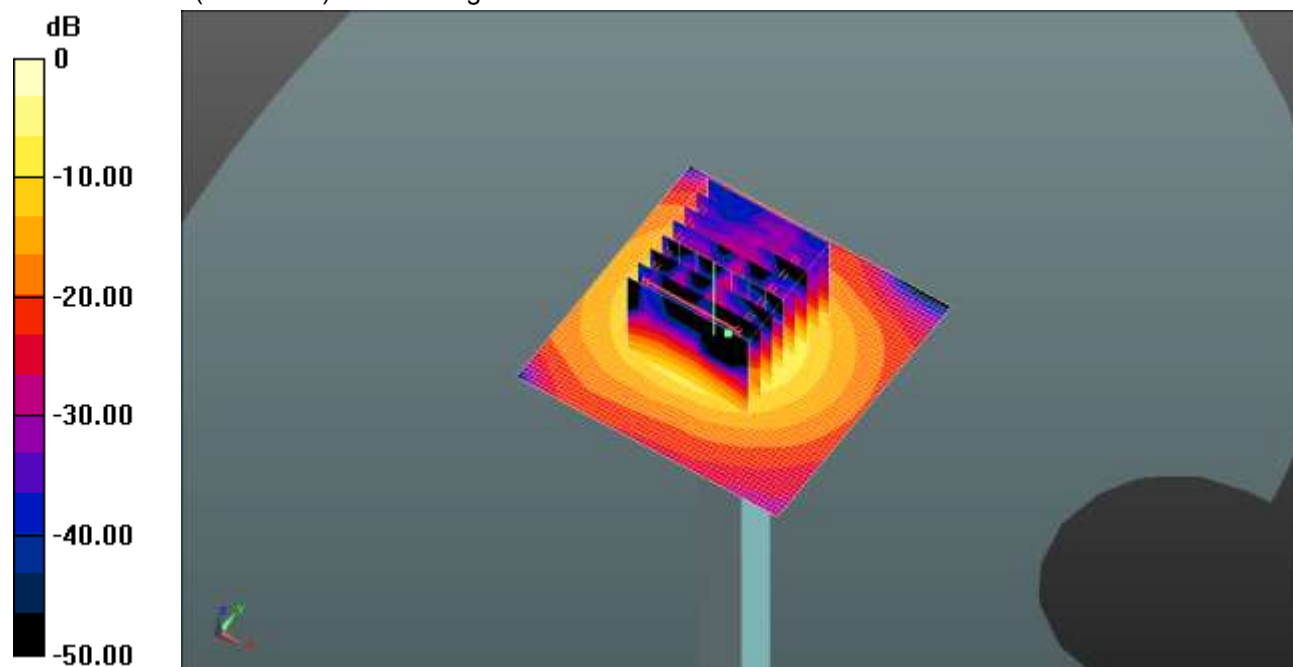

0 dB = 17.9 W/kg = 12.53 dBW/kg

## 20130107 SystemPerformanceCheck-D5GHzV2 SN 1138

Frequency: 5800 MHz; Duty Cycle: 1:1

**Body/5.8 GHz, Pin=100mW/Z Scan (1x1x21):** Measurement grid: dx=20mm, dy=20mm, dz=5mm  
Maximum value of SAR (measured) = 11.3 W/kg

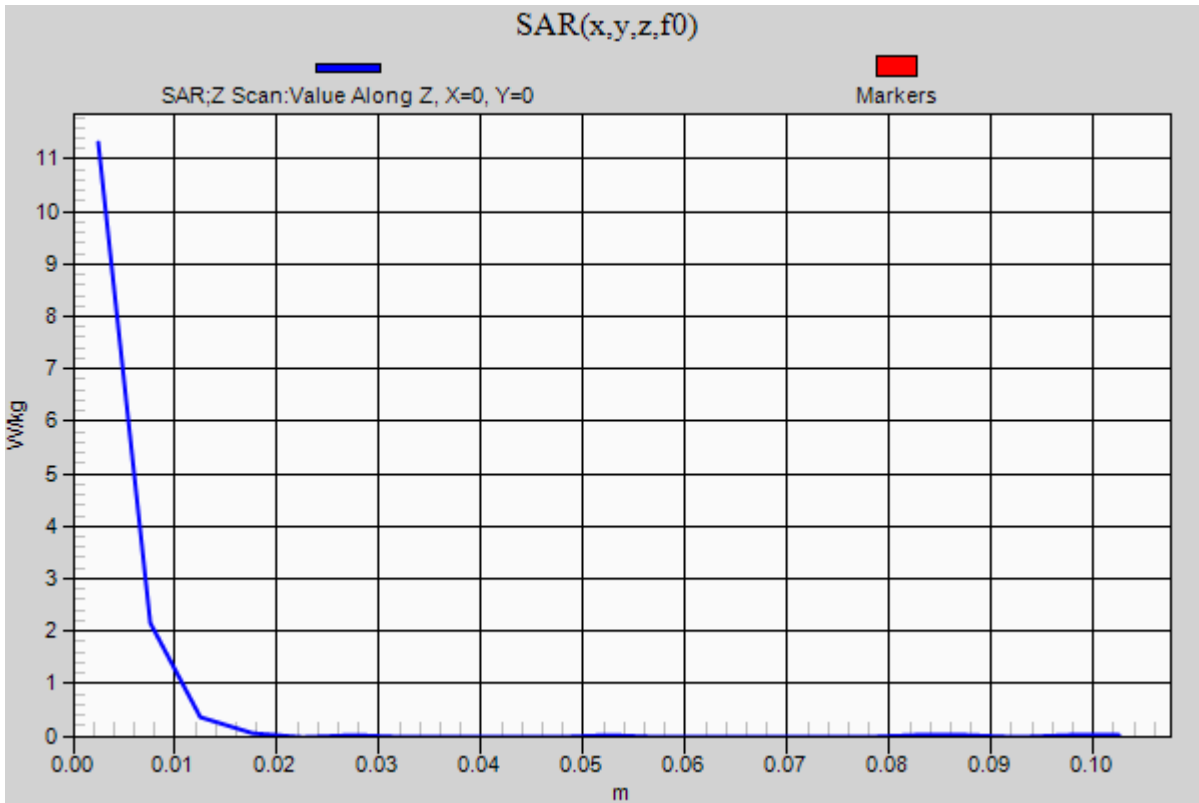

## 20130111 SystemPerformanceCheck-D2450V2 SN 706

Frequency: 2450 MHz; Duty Cycle: 1:1; Room Ambient Temperature: 24.0°C; Liquid Temperature: 23.0°C  
Medium parameters used:  $f = 2450$  MHz;  $\sigma = 1.923$  mho/m;  $\epsilon_r = 51.418$ ;  $\rho = 1000$  kg/m<sup>3</sup>

DASY5 Configuration:

- Area Scan Setting: Find Secondary Maximum Within: 2.0 dB and with a peak SAR value greater than 0.0012W/kg
- Electronics: DAE4 Sn1259; Calibrated: 2/13/2012
- Probe: EX3DV4 - SN3686; ConvF(6.7, 6.7, 6.7); Calibrated: 2/16/2012;
- Sensor-Surface: 2.5mm (Mechanical Surface Detection)
- Phantom: SAM; Type: QD000P40CD; Serial: 1629

**Body/Pin=100 mW/Area Scan (71x71x1):** Interpolated grid: dx=1.200 mm, dy=1.200 mm

Reference Value = 57.990 V/m; Power Drift = 0.06 dB

**Fast SAR: SAR(1 g) = 5.11 W/kg; SAR(10 g) = 2.21 W/kg**

Maximum value of SAR (interpolated) = 7.48 W/kg

**Body/Pin=100 mW/Zoom Scan (7x7x7)/Cube 0:** Measurement grid: dx=5mm, dy=5mm, dz=5mm

Reference Value = 57.990 V/m; Power Drift = 0.06 dB

Peak SAR (extrapolated) = 11.0 W/kg

**SAR(1 g) = 5.05 W/kg; SAR(10 g) = 2.28 W/kg**

Maximum value of SAR (measured) = 7.31 W/kg

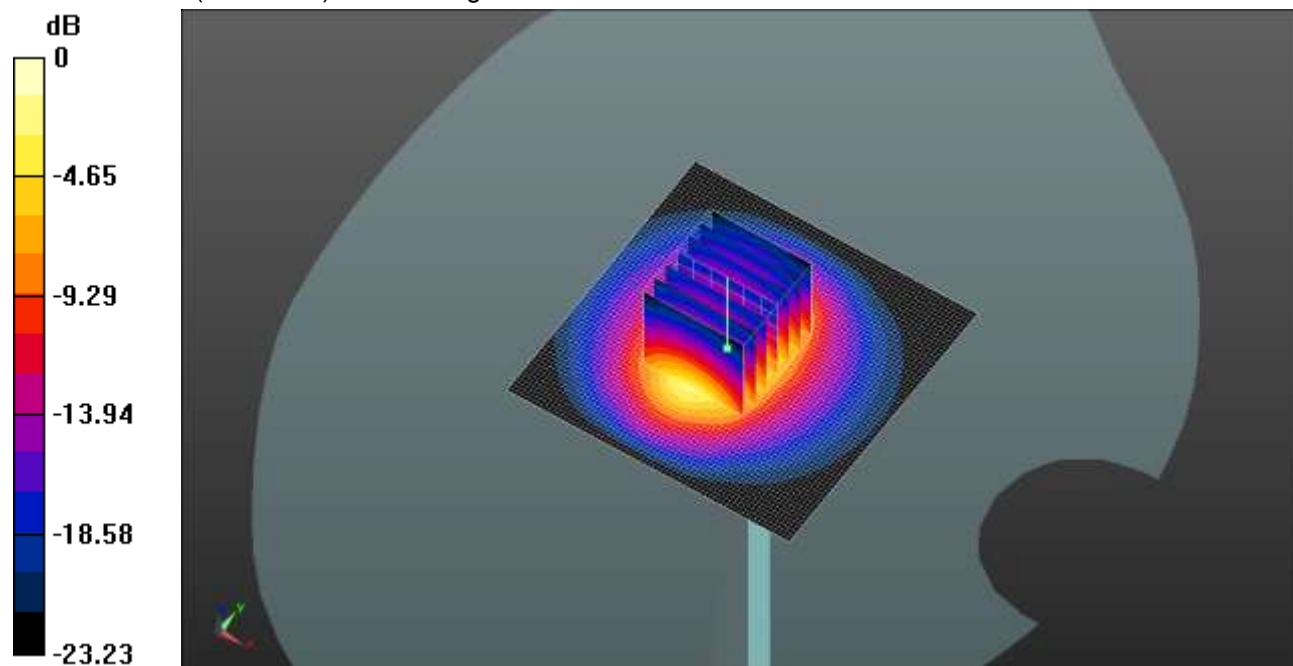

0 dB = 7.31 W/kg = 8.64 dBW/kg

## 20130111 SystemPerformanceCheck-D2450V2 SN 706

Frequency: 2450 MHz; Duty Cycle: 1:1

**Body/Pin=100 mW/Z Scan (1x1x21):** Measurement grid: dx=20mm, dy=20mm, dz=5mm  
Maximum value of SAR (measured) = 6.37 W/kg

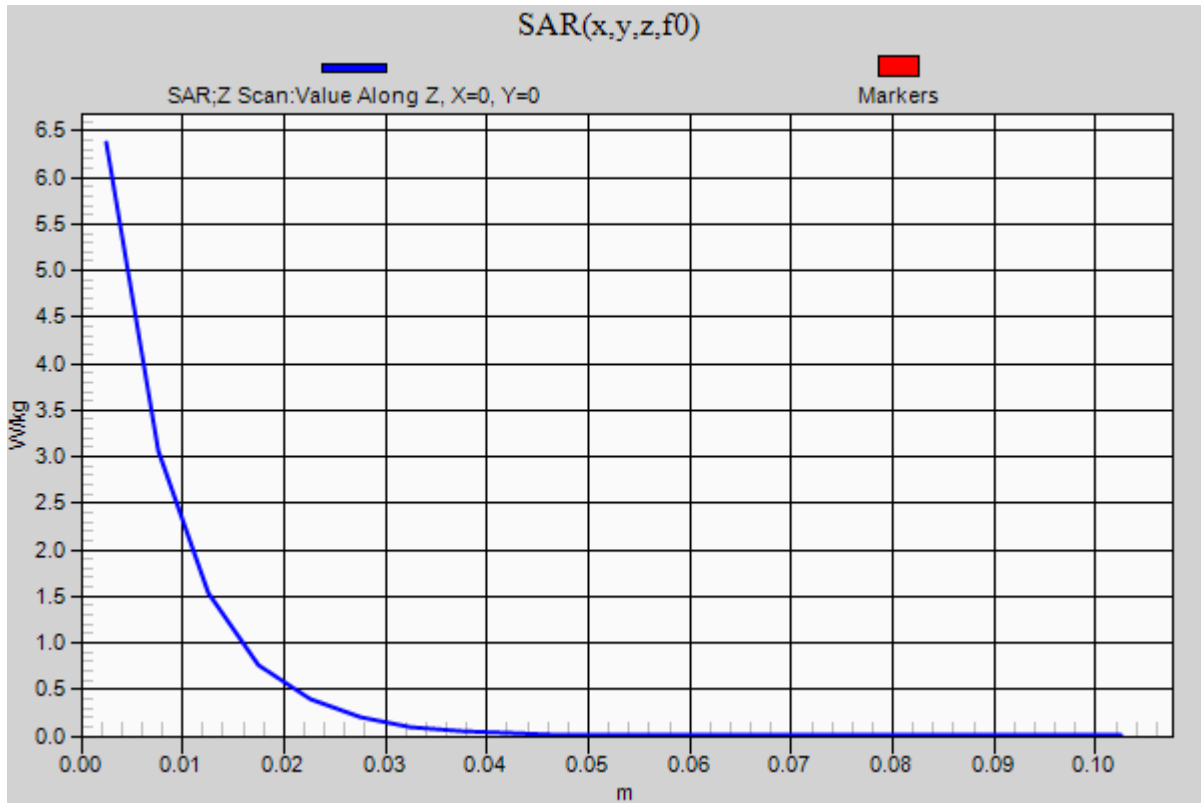

## 20130114SystemPerformanceCheck-D2450V2 SN 706

Frequency: 2450 MHz; Duty Cycle: 1:1; Room Ambient Temperature: 24.0°C; Liquid Temperature: 23.0°C  
Medium parameters used:  $f = 2450$  MHz;  $\sigma = 1.983$  mho/m;  $\epsilon_r = 52.226$ ;  $\rho = 1000$  kg/m<sup>3</sup>

DASY5 Configuration:

- Area Scan Setting: Find Secondary Maximum Within: 2.0 dB and with a peak SAR value greater than 0.0012W/kg
- Electronics: DAE4 Sn1259; Calibrated: 2/13/2012
- Probe: EX3DV4 - SN3686; ConvF(6.7, 6.7, 6.7); Calibrated: 2/16/2012;
- Sensor-Surface: 2.5mm (Mechanical Surface Detection)
- Phantom: ELI v5.0 (A); Type: QDOVA001BB; Serial: 1120

**Body/Pin=100 mW/Area Scan (71x71x1):** Interpolated grid: dx=1.200 mm, dy=1.200 mm

Reference Value = 58.696 V/m; Power Drift = -0.19 dB

**Fast SAR: SAR(1 g) = 5.17 W/kg; SAR(10 g) = 2.22 W/kg**

Maximum value of SAR (interpolated) = 7.57 W/kg

**Body/Pin=100 mW/Zoom Scan (7x7x7)/Cube 0:** Measurement grid: dx=5mm, dy=5mm, dz=5mm

Reference Value = 58.696 V/m; Power Drift = -0.19 dB

Peak SAR (extrapolated) = 10.7 W/kg

**SAR(1 g) = 5.18 W/kg; SAR(10 g) = 2.39 W/kg**

Maximum value of SAR (measured) = 7.37 W/kg

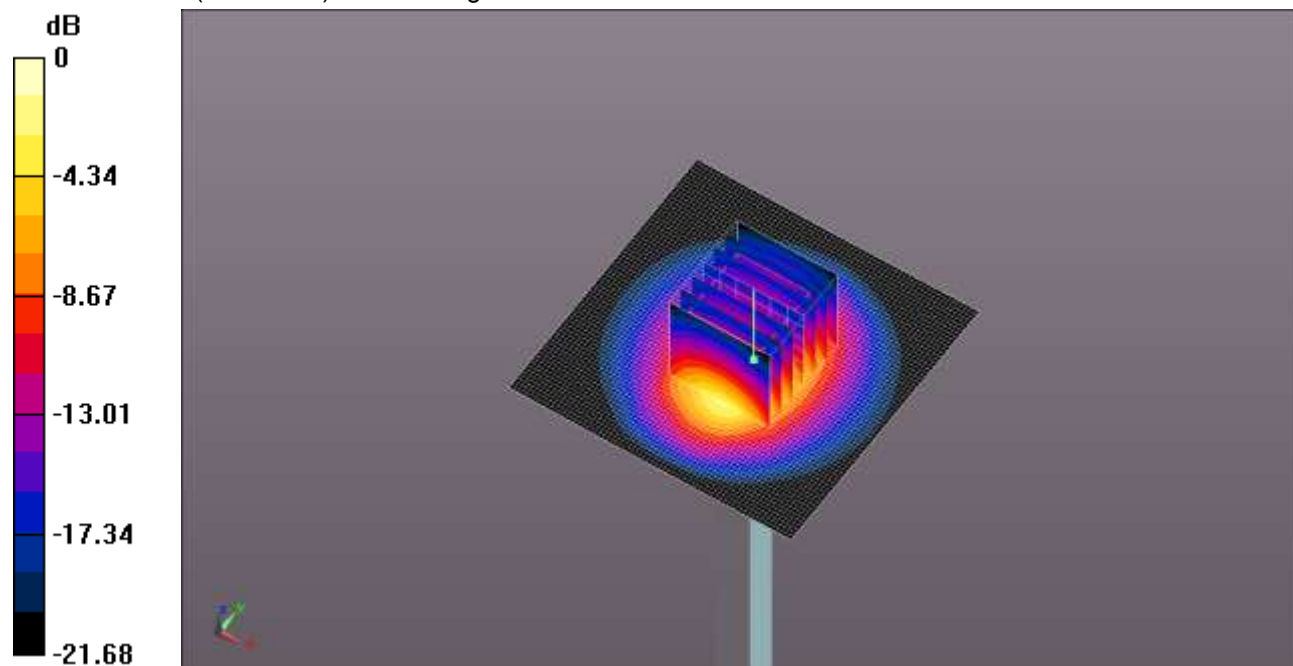

0 dB = 7.37 W/kg = 8.67 dBW/kg

## 20130114 SystemPerformanceCheck-D2450V2 SN 706

Frequency: 2450 MHz; Duty Cycle: 1:1

**Body/Pin=100 mW/Z Scan (1x1x21):** Measurement grid: dx=20mm, dy=20mm, dz=5mm  
Maximum value of SAR (measured) = 6.75 W/kg

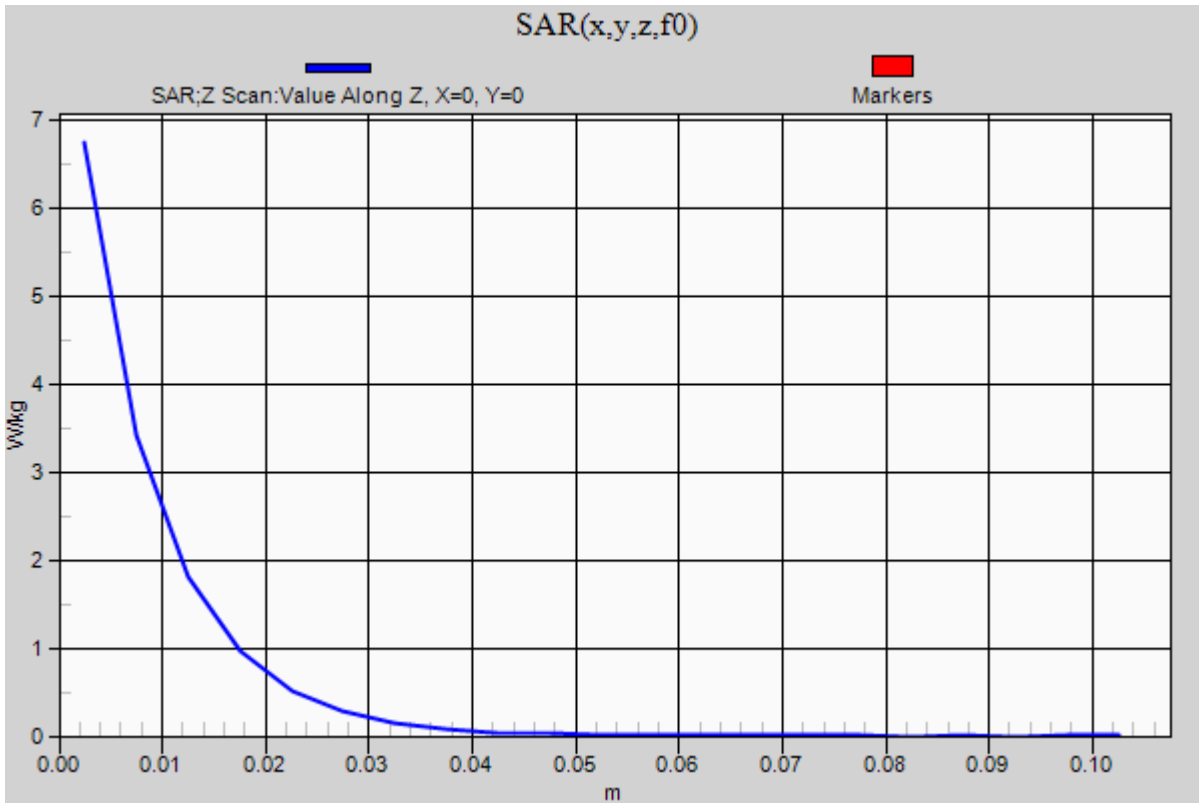

## 20130115 SystemPerformanceCheck-D5GHzV2 SN 1003

Frequency: 5200 MHz; Duty Cycle: 1:1; Room Ambient Temperature: 25.0°C; Liquid Temperature: 24.0°C  
Medium parameters used:  $f = 5200$  MHz;  $\sigma = 5.248$  mho/m;  $\epsilon_r = 47.694$ ;  $\rho = 1000$  kg/m<sup>3</sup>

DASY5 Configuration:

- Area Scan Setting: Find Secondary Maximum Within: 2.0 dB and with a peak SAR value greater than 0.0012W/kg
- Electronics: DAE4 Sn1259; Calibrated: 2/13/2012
- Probe: EX3DV4 - SN3686; ConvF(4.04, 4.04, 4.04); Calibrated: 2/16/2012;
- Sensor-Surface: 1.4mm (Mechanical Surface Detection)
- Phantom: ELI v5.0 (B); Type: QDOVA001BB; Serial: 1118

**Body/5.2 GHz, Pin=100mW/Area Scan (61x61x1):** Interpolated grid: dx=1.000 mm, dy=1.000 mm

Reference Value = 54.783 V/m; Power Drift = 0.00 dB

**Fast SAR: SAR(1 g) = 7.3 W/kg; SAR(10 g) = 1.99 W/kg**

Maximum value of SAR (interpolated) = 19.3 W/kg

**Body/5.2 GHz, Pin=100mW/Zoom Scan (8x8x7)/Cube 0:** Measurement grid: dx=4mm, dy=4mm, dz=1.4mm

Reference Value = 54.783 V/m; Power Drift = 0.00 dB

Peak SAR (extrapolated) = 30.5 W/kg

**SAR(1 g) = 7.81 W/kg; SAR(10 g) = 2.19 W/kg**

Maximum value of SAR (measured) = 18.1 W/kg

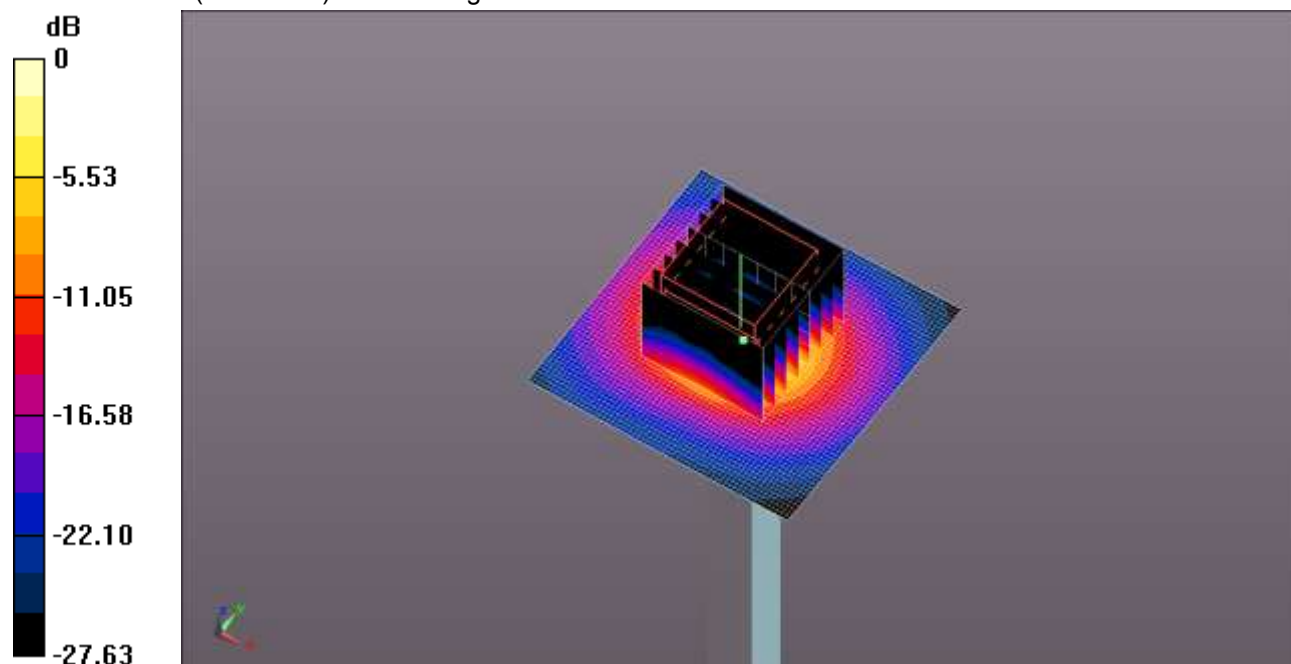

0 dB = 18.1 W/kg = 12.58 dBW/kg

## 20130115 SystemPerformanceCheck-D5GHzV2 SN 1003

Frequency: 5200 MHz; Duty Cycle: 1:1

**Body/5.2 GHz, Pin=100mW/Z Scan (1x1x21):** Measurement grid: dx=20mm, dy=20mm, dz=5mm  
Maximum value of SAR (measured) = 13.4 W/kg

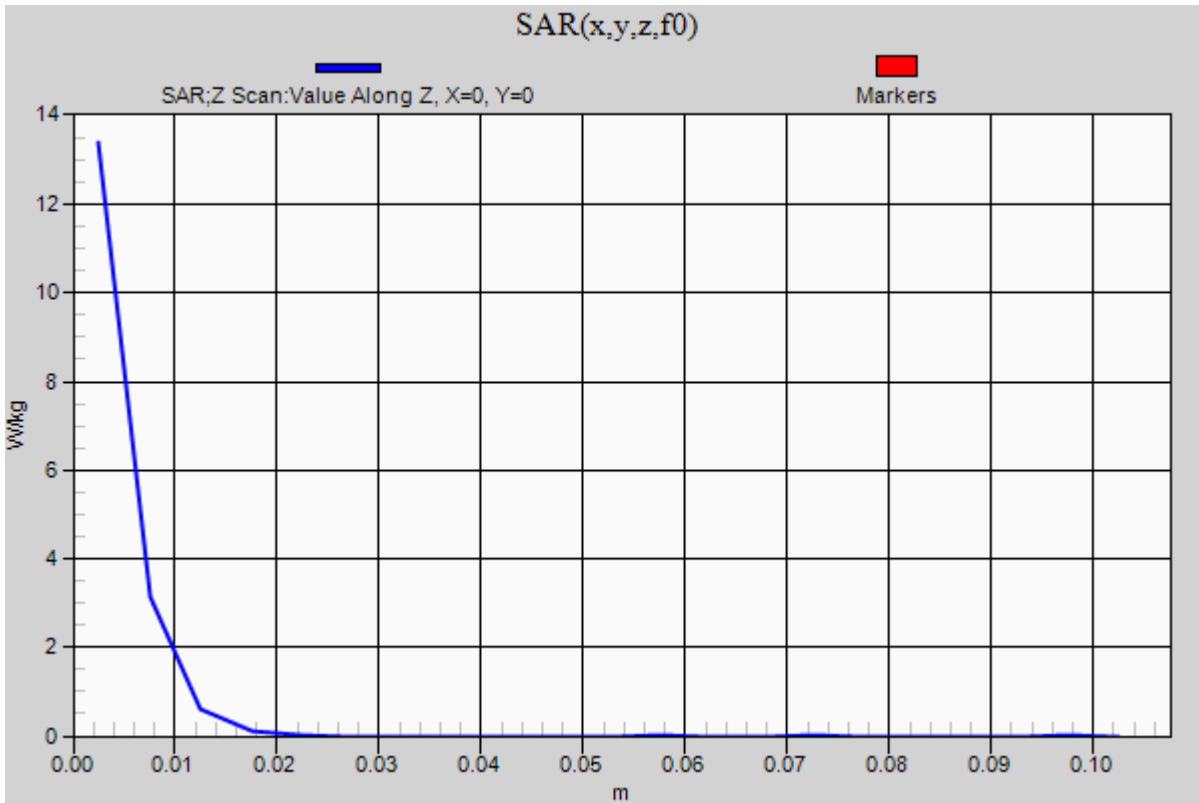

## 20130115 SystemPerformanceCheck-D5GHzV2 SN 1003

Frequency: 5600 MHz; Duty Cycle: 1:1; Room Ambient Temperature: 25.0°C; Liquid Temperature: 24.0°C  
Medium parameters used:  $f = 5600$  MHz;  $\sigma = 5.777$  mho/m;  $\epsilon_r = 47.055$ ;  $\rho = 1000$  kg/m<sup>3</sup>

DASY5 Configuration:

- Area Scan Setting: Find Secondary Maximum Within: 2.0 dB and with a peak SAR value greater than 0.0012W/kg
- Electronics: DAE4 Sn1259; Calibrated: 2/13/2012
- Probe: EX3DV4 - SN3686; ConvF(3.44, 3.44, 3.44); Calibrated: 2/16/2012;
- Sensor-Surface: 1.4mm (Mechanical Surface Detection (Locations From Previous Scan Used)), Sensor-Surface: 1.4mm (Mechanical Surface Detection)
- Phantom: ELI v5.0 (B); Type: QDOVA001BB; Serial: 1118

**Body/5.6 GHz, Pin=100mW/Area Scan (61x61x1):** Interpolated grid: dx=1.000 mm, dy=1.000 mm

Reference Value = 40.437 V/m; Power Drift = 0.18 dB

**Fast SAR: SAR(1 g) = 6.54 W/kg; SAR(10 g) = 1.8 W/kg**

Maximum value of SAR (interpolated) = 17.9 W/kg

**Body/5.6 GHz, Pin=100mW/Zoom Scan (8x8x7)/Cube 0:** Measurement grid: dx=4mm, dy=4mm, dz=1.4mm

Reference Value = 40.437 V/m; Power Drift = 0.18 dB

Peak SAR (extrapolated) = 31.4 W/kg

**SAR(1 g) = 7.54 W/kg; SAR(10 g) = 2.07 W/kg**

Maximum value of SAR (measured) = 18.7 W/kg

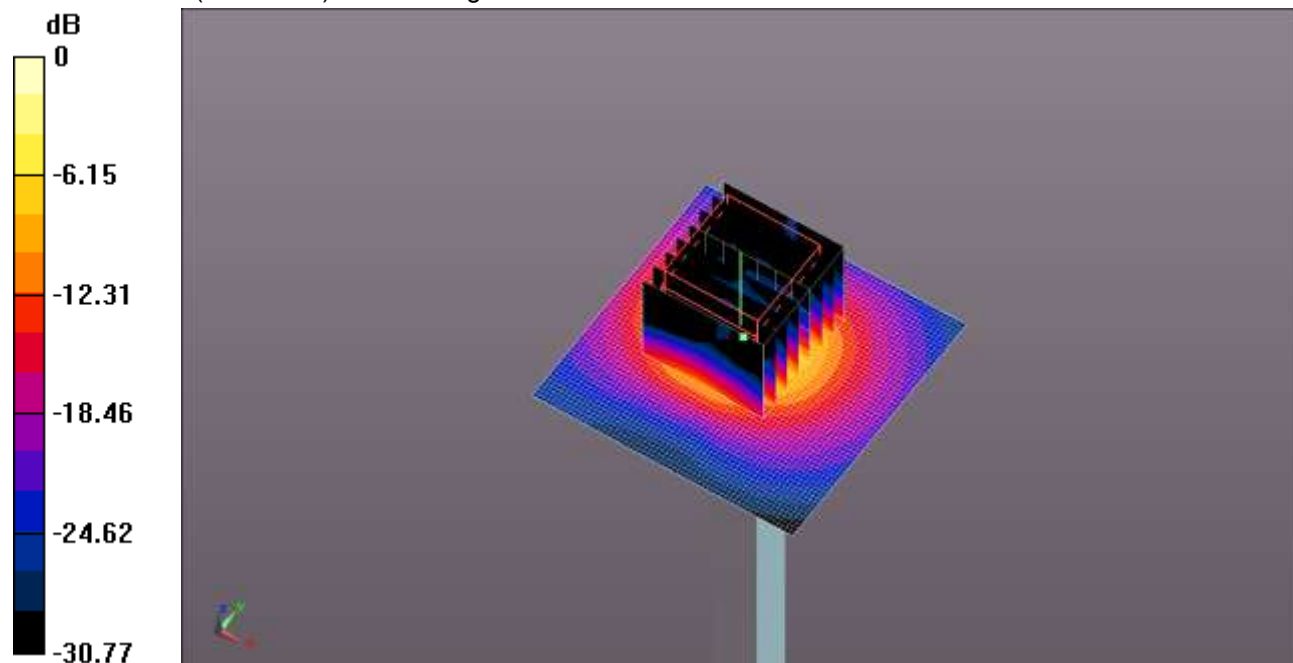

0 dB = 18.7 W/kg = 12.72 dBW/kg

## 20130115 SystemPerformanceCheck-D5GHzV2 SN 1003

Frequency: 5600 MHz; Duty Cycle: 1:1

**Body/5.6 GHz, Pin=100mW/Z Scan (1x1x21):** Measurement grid: dx=20mm, dy=20mm, dz=5mm  
Maximum value of SAR (measured) = 7.96 W/kg

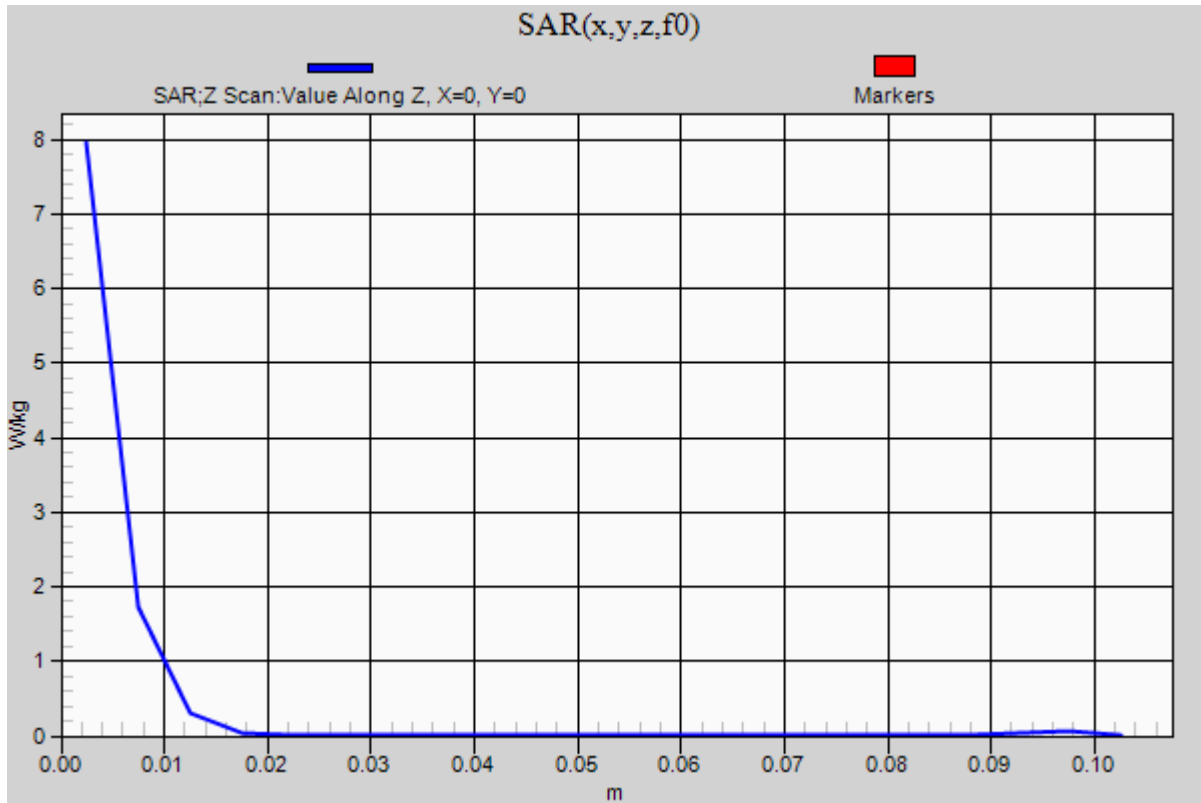

## 20130115 SystemPerformanceCheck-D5GHzV2 SN 1003

Frequency: 5800 MHz; Duty Cycle: 1:1; Room Ambient Temperature: 25.0°C; Liquid Temperature: 24.0°C  
Medium parameters used:  $f = 5800$  MHz;  $\sigma = 6.06$  mho/m;  $\epsilon_r = 46.743$ ;  $\rho = 1000$  kg/m<sup>3</sup>

DASY5 Configuration:

- Area Scan Setting: Find Secondary Maximum Within: 2.0 dB and with a peak SAR value greater than 0.0012W/kg
- Electronics: DAE4 Sn1259; Calibrated: 2/13/2012
- Probe: EX3DV4 - SN3686; ConvF(3.57, 3.57, 3.57); Calibrated: 2/16/2012;
- Sensor-Surface: 1.4mm (Mechanical Surface Detection (Locations From Previous Scan Used)), Sensor-Surface: 1.4mm (Mechanical Surface Detection)
- Phantom: ELI v5.0 (B); Type: QDOVA001BB; Serial: 1118

**Body/5.8 GHz, Pin=100mW/Area Scan (61x61x1):** Interpolated grid: dx=1.000 mm, dy=1.000 mm

Reference Value = 46.305 V/m; Power Drift = 0.13 dB

**Fast SAR: SAR(1 g) = 6.04 W/kg; SAR(10 g) = 1.66 W/kg**

Maximum value of SAR (interpolated) = 16.6 W/kg

**Body/5.8 GHz, Pin=100mW/Zoom Scan (8x8x7)/Cube 0:** Measurement grid: dx=4mm, dy=4mm, dz=1.4mm

Reference Value = 46.305 V/m; Power Drift = 0.13 dB

Peak SAR (extrapolated) = 30.0 W/kg

**SAR(1 g) = 7.04 W/kg; SAR(10 g) = 1.98 W/kg**

Maximum value of SAR (measured) = 17.1 W/kg

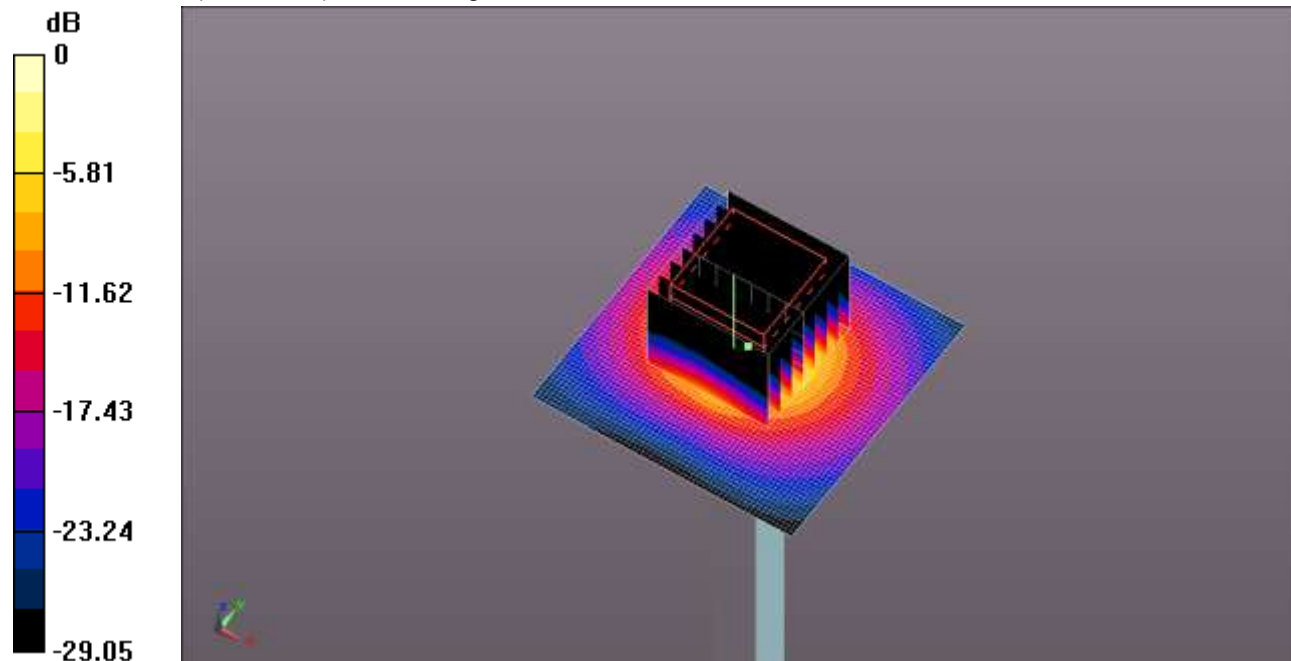

0 dB = 17.1 W/kg = 12.33 dBW/kg

## 20130115 SystemPerformanceCheck-D5GHzV2 SN 1003

Frequency: 5800 MHz; Duty Cycle: 1:1

**Body/5.8 GHz, Pin=100mW/Z Scan (1x1x21):** Measurement grid: dx=20mm, dy=20mm, dz=5mm  
Maximum value of SAR (measured) = 11.1 W/kg

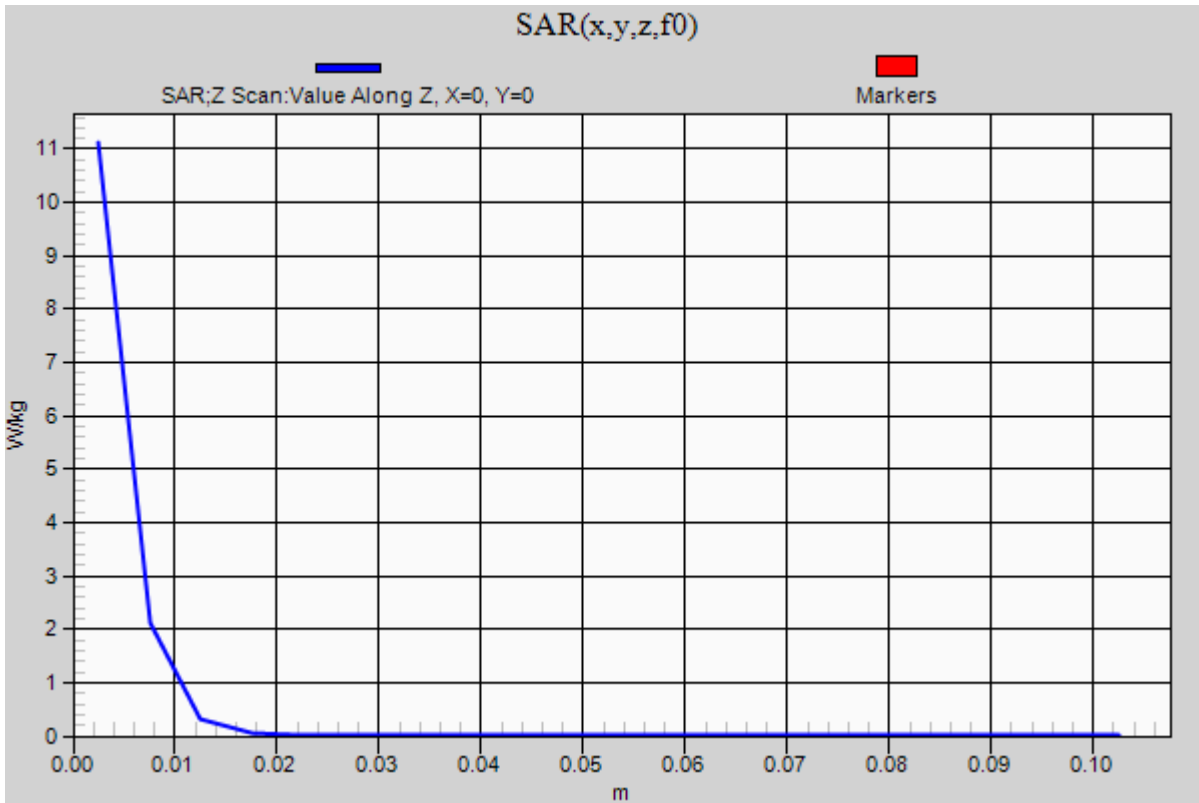

## 20130116 SystemPerformanceCheck-D5GHzV2 SN 1003

Frequency: 5200 MHz; Duty Cycle: 1:1; Room Ambient Temperature: 25.0°C; Liquid Temperature: 24.0°C  
Medium parameters used:  $f = 5200$  MHz;  $\sigma = 5.412$  mho/m;  $\epsilon_r = 47.368$ ;  $\rho = 1000$  kg/m<sup>3</sup>

DASY5 Configuration:

- Area Scan Setting: Find Secondary Maximum Within: 2.0 dB and with a peak SAR value greater than 0.0012W/kg
- Electronics: DAE4 Sn1259; Calibrated: 2/13/2012
- Probe: EX3DV4 - SN3686; ConvF(4.04, 4.04, 4.04); Calibrated: 2/16/2012;
- Sensor-Surface: 1.4mm (Mechanical Surface Detection)
- Phantom: SAM; Type: QD000P40CD; Serial: 1629

**Body/5.2 GHz, Pin=100mW/Area Scan (61x61x1):** Interpolated grid: dx=1.000 mm, dy=1.000 mm

Reference Value = 51.989 V/m; Power Drift = -0.04 dB

**Fast SAR: SAR(1 g) = 7.22 W/kg; SAR(10 g) = 1.98 W/kg**

Maximum value of SAR (interpolated) = 18.7 W/kg

**Body/5.2 GHz, Pin=100mW/Zoom Scan (8x8x7)/Cube 0:** Measurement grid: dx=4mm, dy=4mm, dz=1.4mm

Reference Value = 51.989 V/m; Power Drift = -0.04 dB

Peak SAR (extrapolated) = 30.0 W/kg

**SAR(1 g) = 7.56 W/kg; SAR(10 g) = 2.14 W/kg**

Maximum value of SAR (measured) = 18.1 W/kg

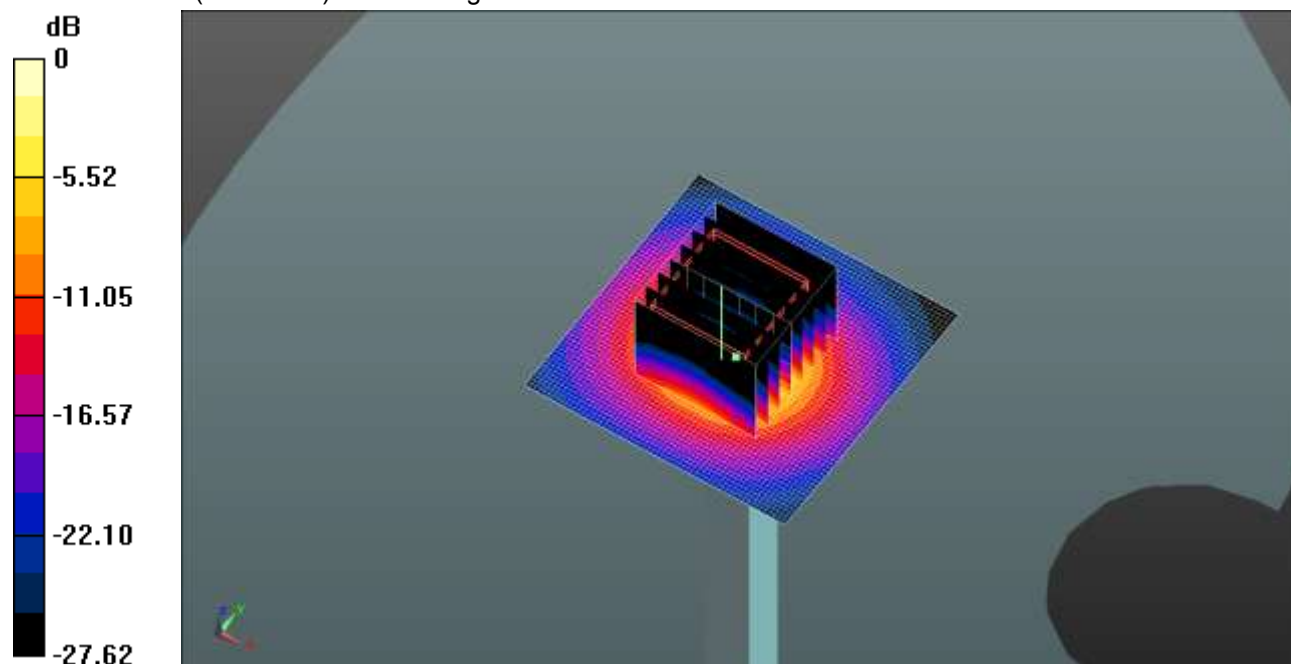

0 dB = 18.1 W/kg = 12.58 dBW/kg

## 20130116 SystemPerformanceCheck-D5GHzV2 SN 1003

Frequency: 5200 MHz; Duty Cycle: 1:1

**Body/5.2 GHz, Pin=100mW/Z Scan (1x1x21):** Measurement grid: dx=20mm, dy=20mm, dz=5mm  
Maximum value of SAR (measured) = 12.6 W/kg

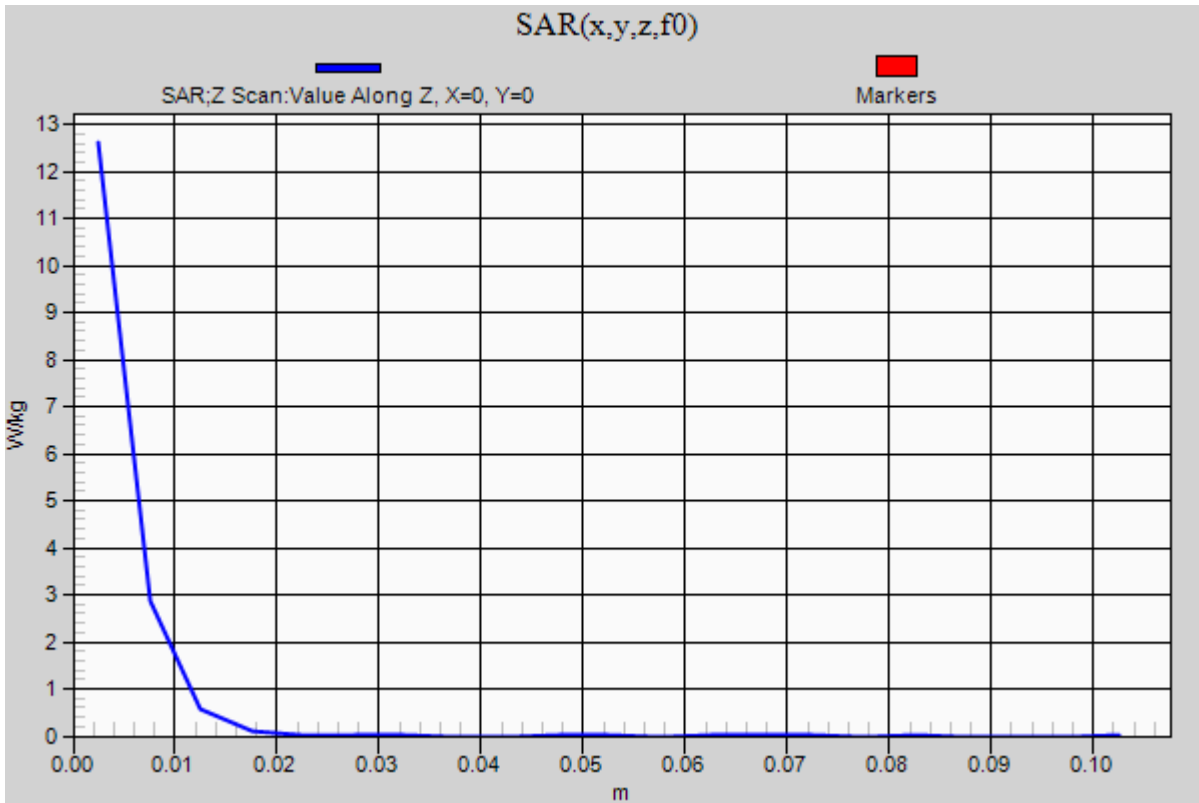

## 20130116 SystemPerformanceCheck-D5GHzV2 SN 1003

Frequency: 5600 MHz; Duty Cycle: 1:1; Room Ambient Temperature: 25.0°C; Liquid Temperature: 24.0°C  
Medium parameters used:  $f = 5600$  MHz;  $\sigma = 5.9$  mho/m;  $\epsilon_r = 46.728$ ;  $\rho = 1000$  kg/m<sup>3</sup>

DASY5 Configuration:

- Area Scan Setting: Find Secondary Maximum Within: 2.0 dB and with a peak SAR value greater than 0.0012W/kg
- Electronics: DAE4 Sn1259; Calibrated: 2/13/2012
- Probe: EX3DV4 - SN3686; ConvF(3.44, 3.44, 3.44); Calibrated: 2/16/2012;
- Sensor-Surface: 1.4mm (Mechanical Surface Detection (Locations From Previous Scan Used)), Sensor-Surface: 1.4mm (Mechanical Surface Detection)
- Phantom: SAM; Type: QD000P40CD; Serial: 1629

**Body/5.6 GHz, Pin=100mW/Area Scan (61x61x1):** Interpolated grid: dx=1.000 mm, dy=1.000 mm

Reference Value = 52.750 V/m; Power Drift = -0.03 dB

**Fast SAR: SAR(1 g) = 8.58 W/kg; SAR(10 g) = 2.3 W/kg**

Maximum value of SAR (interpolated) = 23.4 W/kg

**Body/5.6 GHz, Pin=100mW/Zoom Scan (8x8x7)/Cube 0:** Measurement grid: dx=4mm, dy=4mm, dz=1.4mm

Reference Value = 52.750 V/m; Power Drift = -0.03 dB

Peak SAR (extrapolated) = 34.0 W/kg

**SAR(1 g) = 8.06 W/kg; SAR(10 g) = 2.24 W/kg**

Maximum value of SAR (measured) = 19.4 W/kg

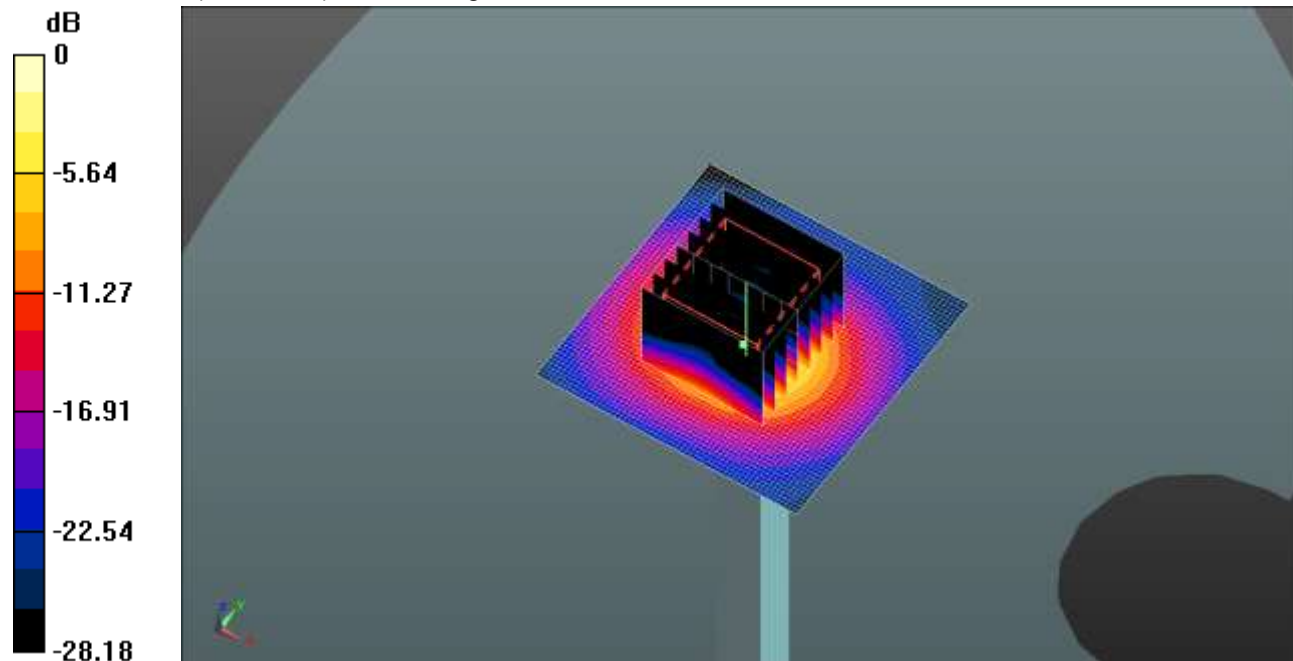

0 dB = 19.4 W/kg = 12.88 dBW/kg

### 20130116 SystemPerformanceCheck-D5GHzV2 SN 1003

Frequency: 5600 MHz; Duty Cycle: 1:1

**Body/5.6 GHz, Pin=100mW/Z Scan (1x1x21):** Measurement grid: dx=20mm, dy=20mm, dz=5mm  
Maximum value of SAR (measured) = 13.9 W/kg

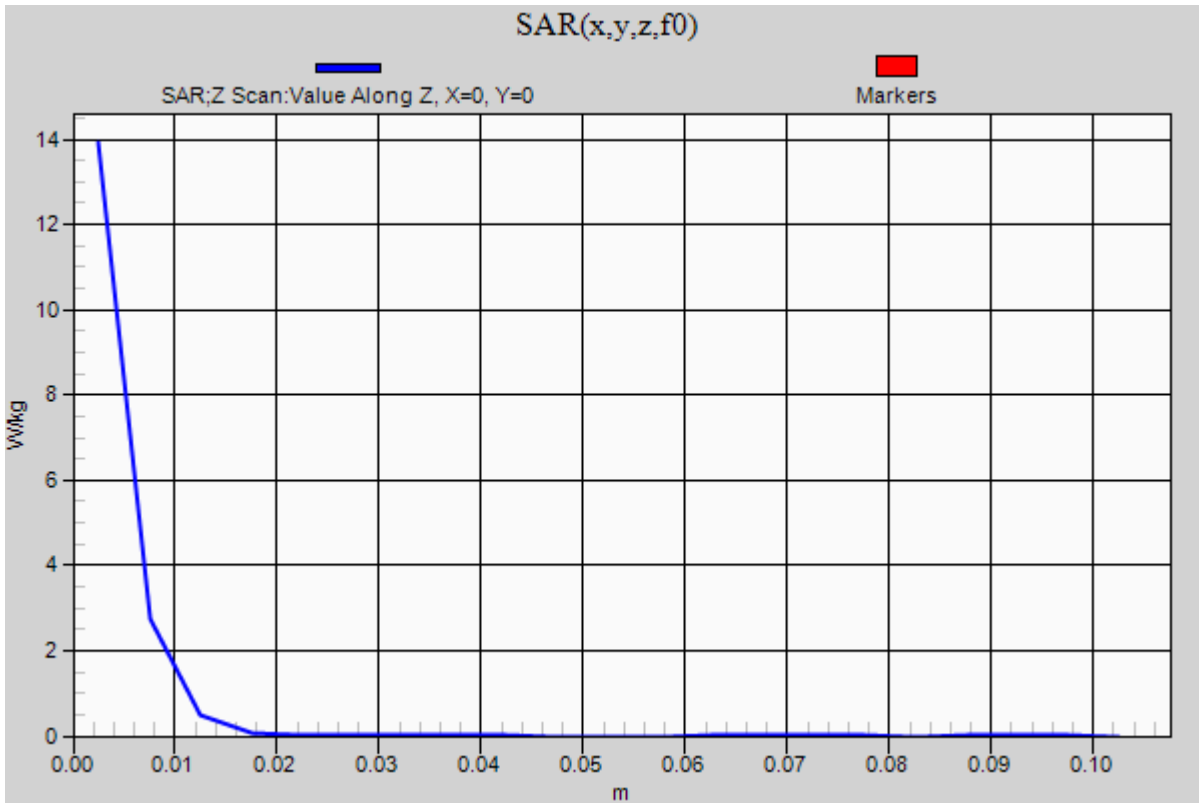

## 20130116 SystemPerformanceCheck-D5GHzV2 SN 1003

Frequency: 5800 MHz; Duty Cycle: 1:1; Room Ambient Temperature: 25.0°C; Liquid Temperature: 24.0°C  
Medium parameters used:  $f = 5800$  MHz;  $\sigma = 6.153$  mho/m;  $\epsilon_r = 46.455$ ;  $\rho = 1000$  kg/m<sup>3</sup>

DASY5 Configuration:

- Area Scan Setting: Find Secondary Maximum Within: 2.0 dB and with a peak SAR value greater than 0.0012W/kg
- Electronics: DAE4 Sn1259; Calibrated: 2/13/2012
- Probe: EX3DV4 - SN3686; ConvF(3.57, 3.57, 3.57); Calibrated: 2/16/2012;
- Sensor-Surface: 1.4mm (Mechanical Surface Detection (Locations From Previous Scan Used)), Sensor-Surface: 1.4mm (Mechanical Surface Detection)
- Phantom: SAM; Type: QD000P40CD; Serial: 1629

**Body/5.8 GHz, Pin=100mW/Area Scan (61x61x1):** Interpolated grid: dx=1.000 mm, dy=1.000 mm

Reference Value = 49.933 V/m; Power Drift = 0.02 dB

**Fast SAR: SAR(1 g) = 8.44 W/kg; SAR(10 g) = 2.27 W/kg**

Maximum value of SAR (interpolated) = 23.5 W/kg

**Body/5.8 GHz, Pin=100mW/Zoom Scan (8x8x7)/Cube 0:** Measurement grid: dx=4mm, dy=4mm, dz=1.4mm

Reference Value = 49.933 V/m; Power Drift = 0.02 dB

Peak SAR (extrapolated) = 31.9 W/kg

**SAR(1 g) = 7.52 W/kg; SAR(10 g) = 2.09 W/kg**

Maximum value of SAR (measured) = 18.1 W/kg

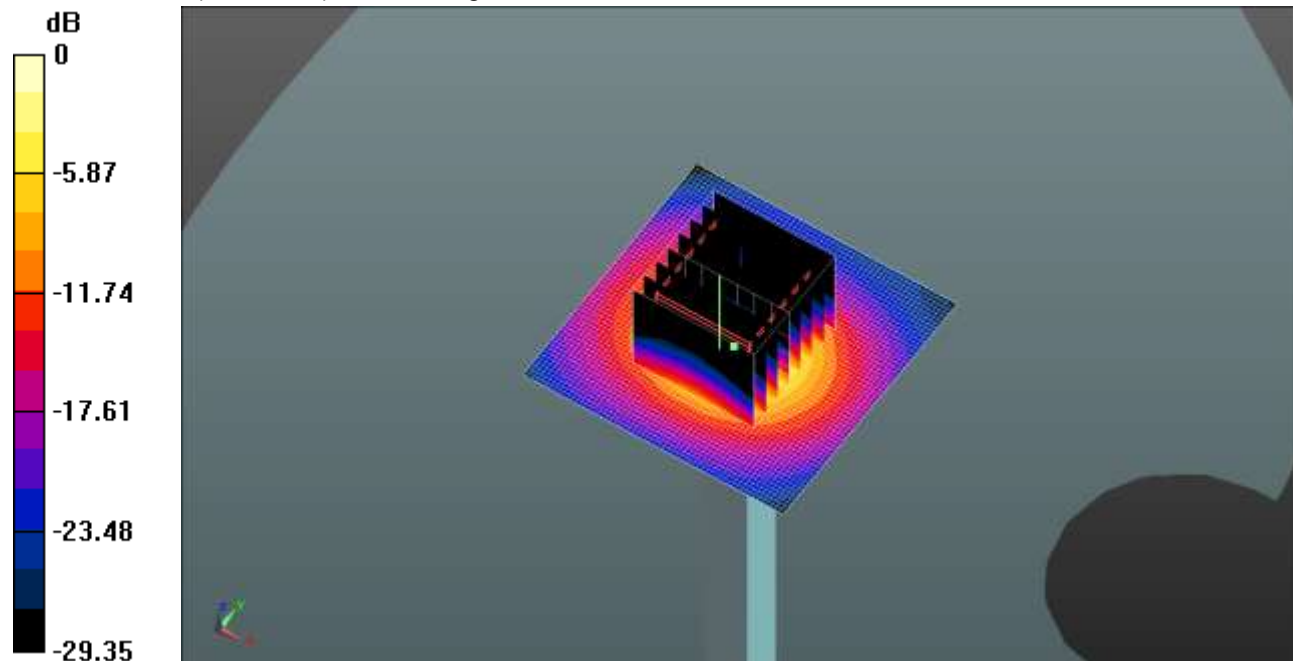

0 dB = 18.1 W/kg = 12.58 dBW/kg

## 20130116 SystemPerformanceCheck-D5GHzV2 SN 1003

Frequency: 5800 MHz; Duty Cycle: 1:1

**Body/5.8 GHz, Pin=100mW/Z Scan (1x1x21):** Measurement grid: dx=20mm, dy=20mm, dz=5mm  
Maximum value of SAR (measured) = 13.0 W/kg

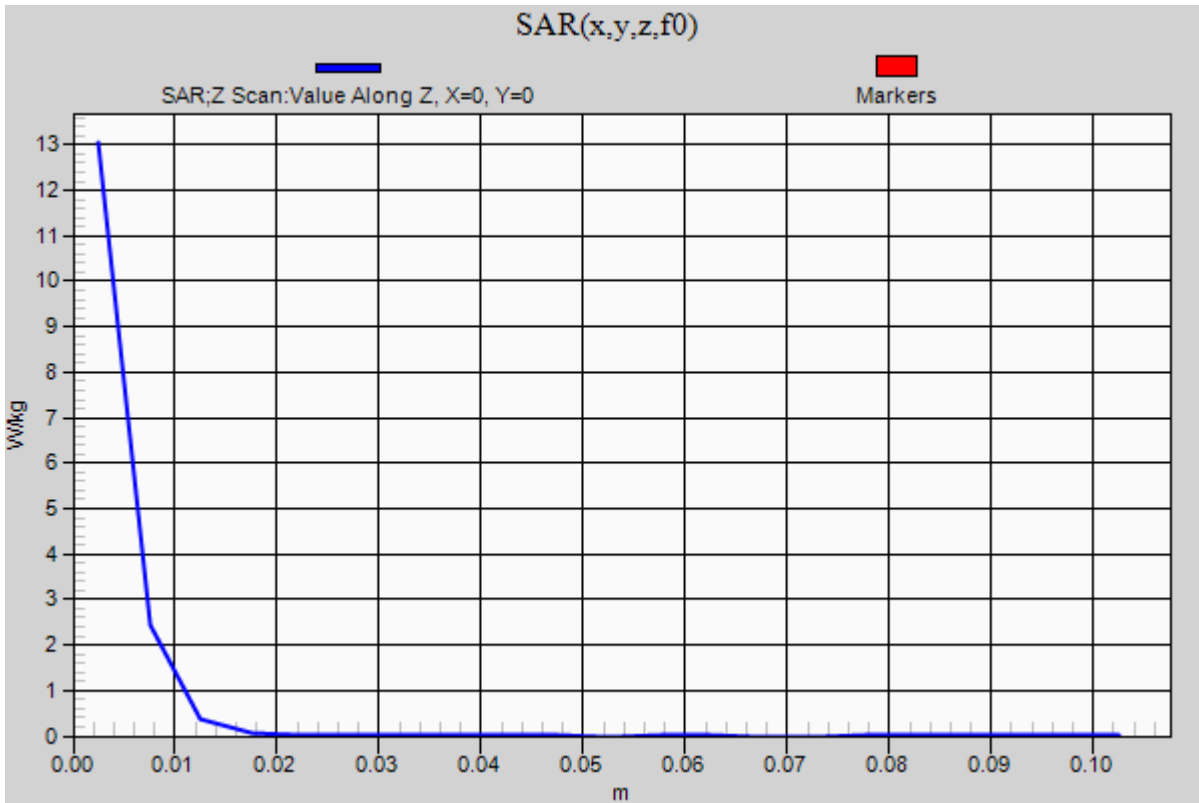

## 20130116 SystemPerformanceCheck-D2450V2 SN 706

Frequency: 2450 MHz; Duty Cycle: 1:1; Room Ambient Temperature: 24.0°C; Liquid Temperature: 23.0°C  
Medium parameters used:  $f = 2450$  MHz;  $\sigma = 1.972$  mho/m;  $\epsilon_r = 50.697$ ;  $\rho = 1000$  kg/m<sup>3</sup>

DASY5 Configuration:

- Area Scan Setting: Find Secondary Maximum Within: 2.0 dB and with a peak SAR value greater than 0.0012W/kg
- Electronics: DAE4 Sn1259; Calibrated: 2/13/2012
- Probe: EX3DV4 - SN3686; ConvF(6.7, 6.7, 6.7); Calibrated: 2/16/2012;
- Sensor-Surface: 2.5mm (Mechanical Surface Detection)
- Phantom: SAM; Type: QD000P40CD; Serial: 1629

**Body/Pin=100 mW/Area Scan (71x71x1):** Interpolated grid: dx=1.200 mm, dy=1.200 mm

Reference Value = 59.646 V/m; Power Drift = 0.06 dB

**Fast SAR: SAR(1 g) = 5.09 W/kg; SAR(10 g) = 2.2 W/kg**

Maximum value of SAR (interpolated) = 7.47 W/kg

**Body/Pin=100 mW/Zoom Scan (7x7x7)/Cube 0:** Measurement grid: dx=5mm, dy=5mm, dz=5mm

Reference Value = 59.646 V/m; Power Drift = 0.06 dB

Peak SAR (extrapolated) = 10.6 W/kg

**SAR(1 g) = 5.08 W/kg; SAR(10 g) = 2.36 W/kg**

Maximum value of SAR (measured) = 7.26 W/kg

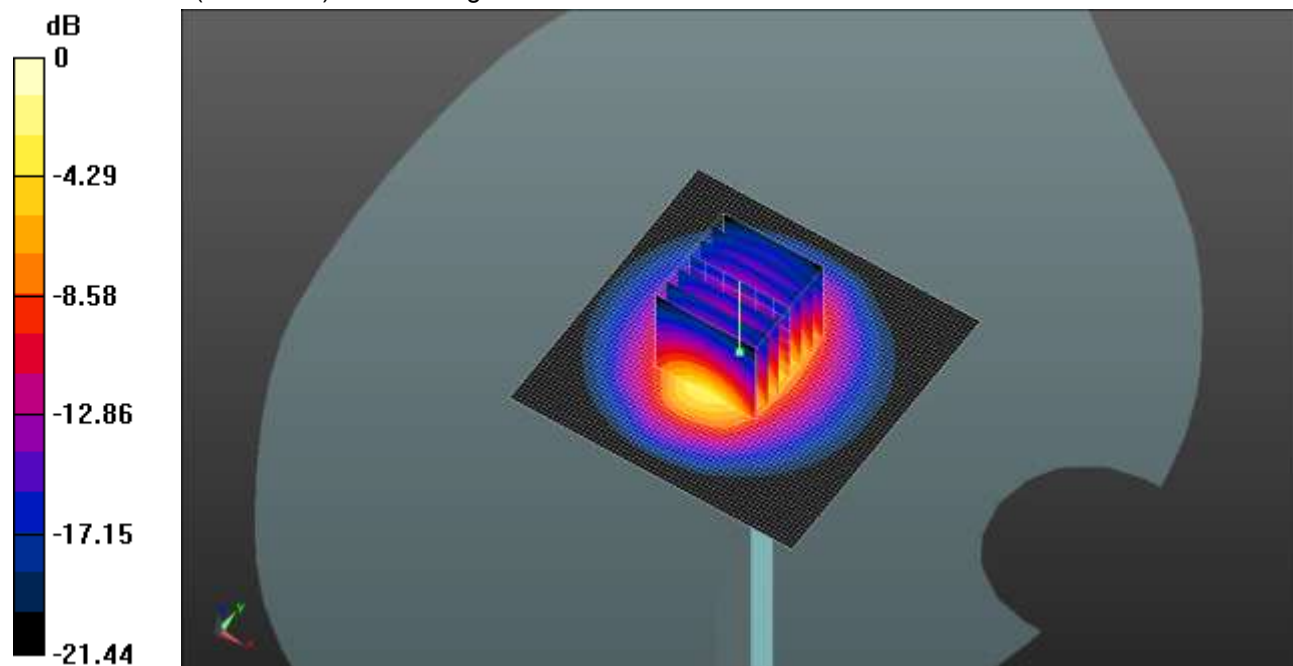

0 dB = 7.26 W/kg = 8.61 dBW/kg

## 20130116 SystemPerformanceCheck-D2450V2 SN 706

Frequency: 2450 MHz; Duty Cycle: 1:1

**Body/Pin=100 mW/Z Scan (1x1x21):** Measurement grid: dx=20mm, dy=20mm, dz=5mm  
Maximum value of SAR (measured) = 6.95 W/kg

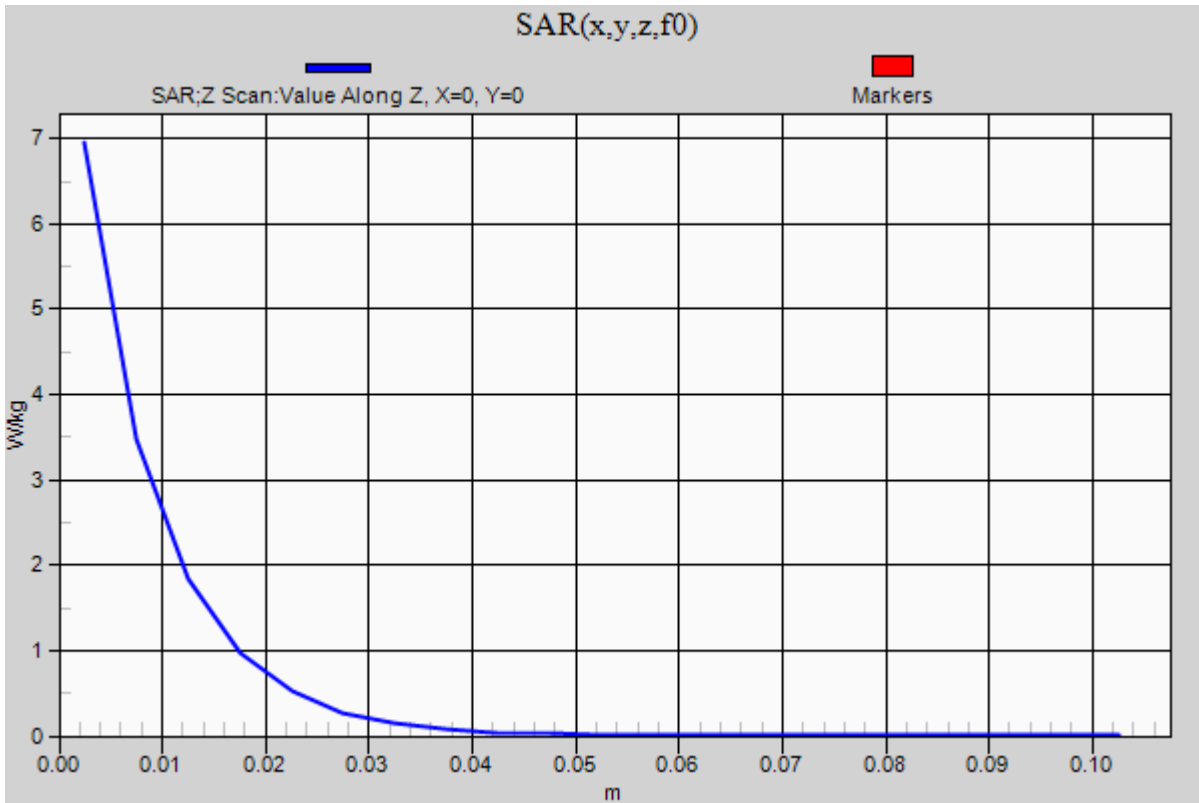

## 20130124 SystemPerformanceCheck-D2450V2 SN 706

Frequency: 2450 MHz; Duty Cycle: 1:1; Room Ambient Temperature: 24.0°C; Liquid Temperature: 23.0°C  
Medium parameters used:  $f = 2450$  MHz;  $\sigma = 1.96$  mho/m;  $\epsilon_r = 53.085$ ;  $\rho = 1000$  kg/m<sup>3</sup>

DASY5 Configuration:

- Area Scan Setting: Find Secondary Maximum Within: 2.0 dB and with a peak SAR value greater than 0.0012W/kg
- Electronics: DAE4 Sn1259; Calibrated: 2/13/2012
- Probe: EX3DV4 - SN3686; ConvF(6.7, 6.7, 6.7); Calibrated: 2/16/2012;
- Sensor-Surface: 2.5mm (Mechanical Surface Detection)
- Phantom: SAM; Type: QD000P40CD; Serial: 1629

**Body/Pin=100 mW/Area Scan (71x71x1):** Interpolated grid: dx=1.200 mm, dy=1.200 mm

Reference Value = 55.002 V/m; Power Drift = 0.16 dB

**Fast SAR: SAR(1 g) = 4.99 W/kg; SAR(10 g) = 2.13 W/kg**

Maximum value of SAR (interpolated) = 7.26 W/kg

**Body/Pin=100 mW/Zoom Scan (7x7x7)/Cube 0:** Measurement grid: dx=5mm, dy=5mm, dz=5mm

Reference Value = 55.002 V/m; Power Drift = 0.16 dB

Peak SAR (extrapolated) = 10.6 W/kg

**SAR(1 g) = 5.07 W/kg; SAR(10 g) = 2.34 W/kg**

Maximum value of SAR (measured) = 7.27 W/kg

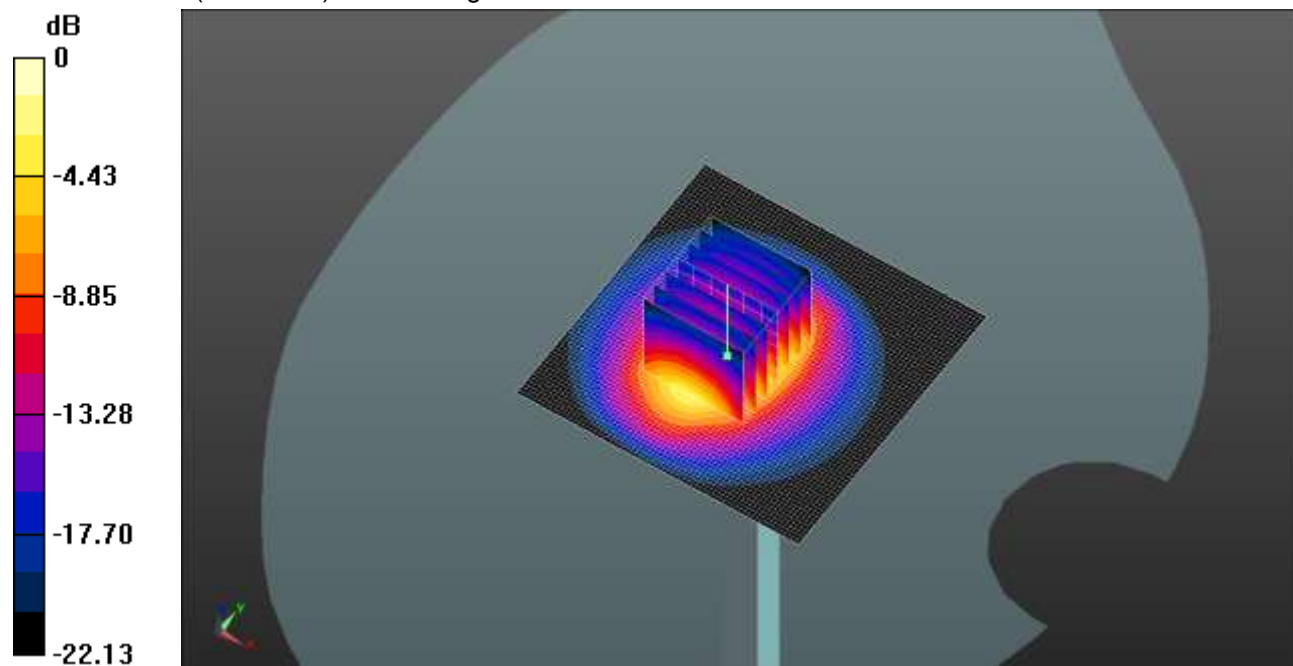

0 dB = 7.27 W/kg = 8.62 dBW/kg

## 20130124 SystemPerformanceCheck-D2450V2 SN 706

Frequency: 2450 MHz; Duty Cycle: 1:1

**Body/Pin=100 mW/Z Scan (1x1x21):** Measurement grid: dx=20mm, dy=20mm, dz=5mm  
Maximum value of SAR (measured) = 5.98 W/kg

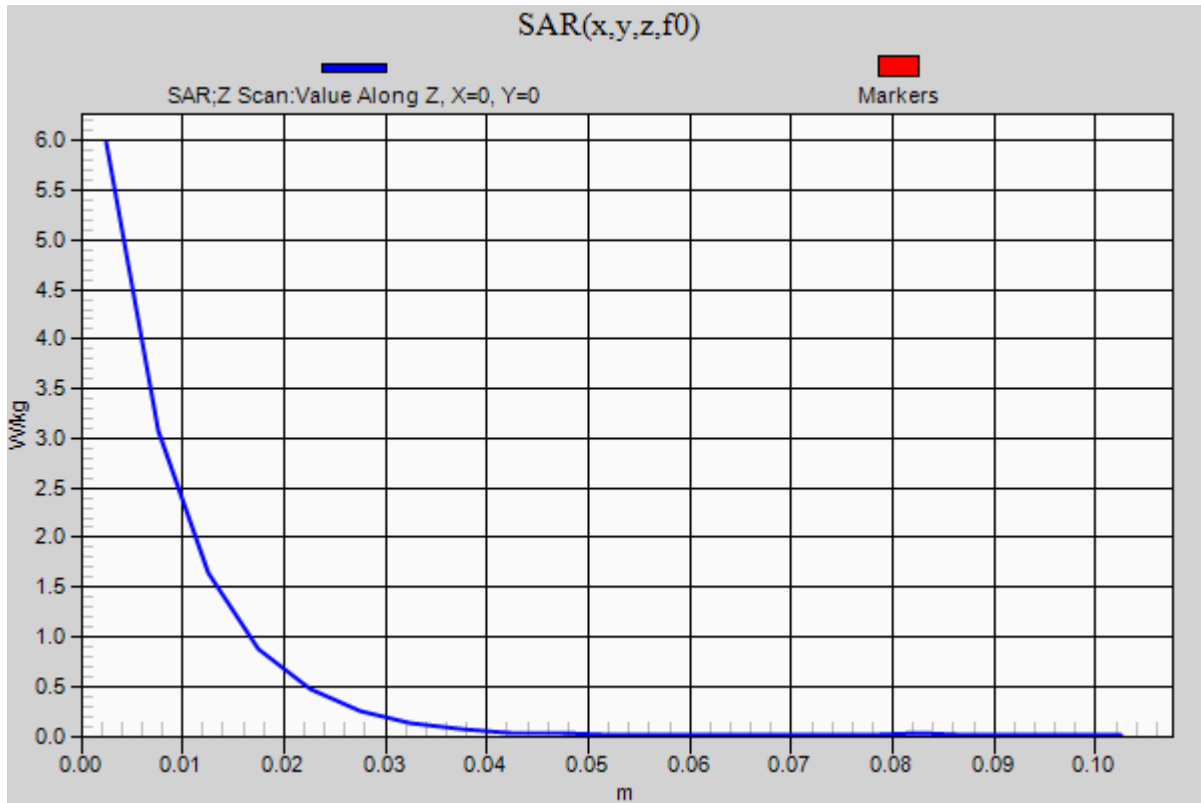

### 20130213 SystemPerformanceCheck-D5GHzV2 SN 1138

Frequency: 5200 MHz; Duty Cycle: 1:1; Room Ambient Temperature: 24.0°C; Liquid Temperature: 23.0°C  
 Medium parameters used:  $f = 5200 \text{ MHz}$ ;  $\sigma = 5.423 \text{ S/m}$ ;  $\epsilon_r = 47.069$ ;  $\rho = 1000 \text{ kg/m}^3$

DASY5 Configuration:

- Area Scan Setting: Find Secondary Maximum Within: 2.0 dB and with a peak SAR value greater than 0.0012W/kg
- Electronics: DAE4 Sn1239; Calibrated: 6/6/2012
- Probe: EX3DV4 - SN3773; ConvF(4.15, 4.15, 4.15); Calibrated: 3/14/2012;
- Sensor-Surface: 1.4mm (Mechanical Surface Detection)
- Phantom: ELI v5.0 (A); Type: QDOVA001BB; Serial: 1117

**Body/5.2 GHz, Pin=100mW/Area Scan (7x7x1):** Measurement grid: dx=10mm, dy=10mm  
 Maximum value of SAR (measured) = 19.9 W/kg

**Body/5.2 GHz, Pin=100mW/Zoom Scan (8x8x7)/Cube 0:** Measurement grid: dx=4mm, dy=4mm, dz=1.4mm

Reference Value = 53.911 V/m; Power Drift = 0.07 dB

Peak SAR (extrapolated) = 33.2 W/kg

**SAR(1 g) = 8.15 W/kg; SAR(10 g) = 2.3 W/kg**

Maximum value of SAR (measured) = 18.8 W/kg

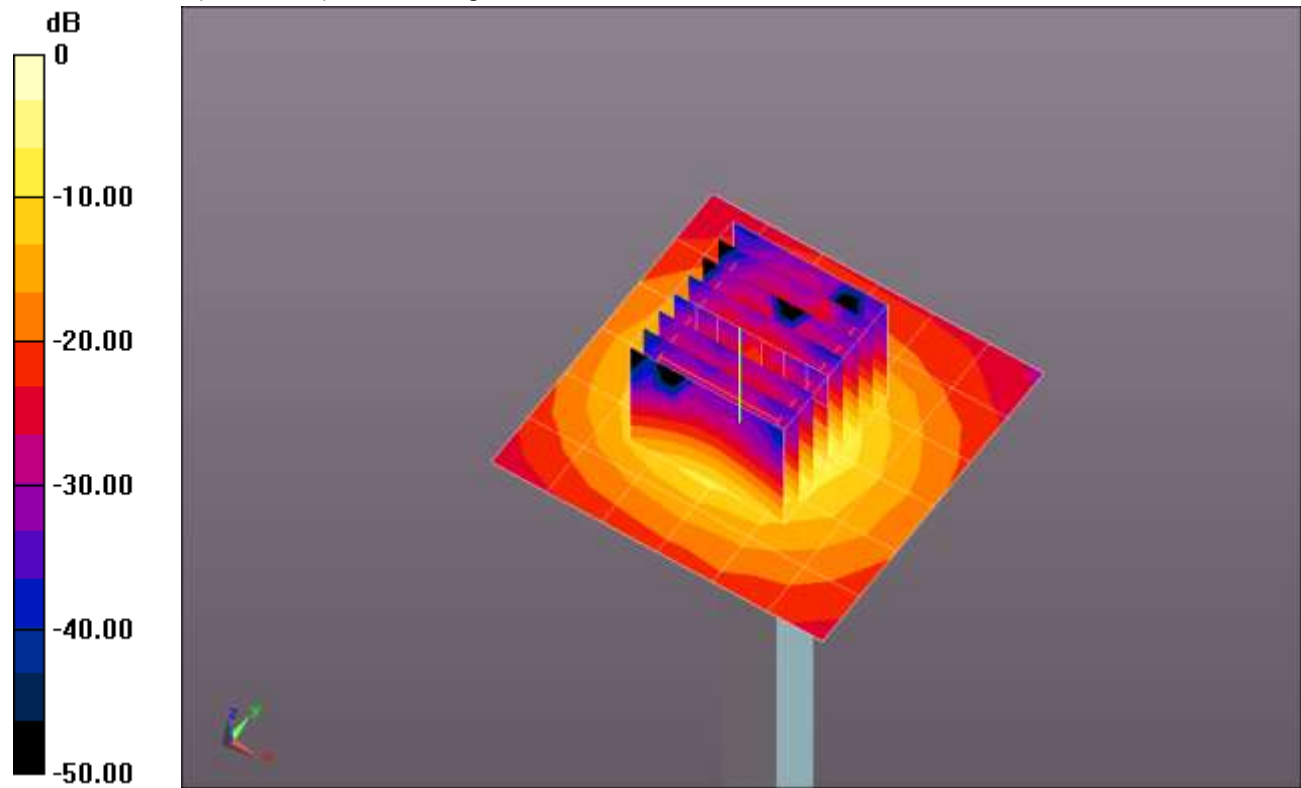

0 dB = 18.8 W/kg = 12.74 dBW/kg

### 20130213 SystemPerformanceCheck-D5GHzV2 SN 1138

Frequency: 5200 MHz; Duty Cycle: 1:1

**Body/5.2 GHz, Pin=100mW/Z Scan (1x1x21):** Measurement grid: dx=20mm, dy=20mm, dz=5mm  
Maximum value of SAR (measured) = 14.3 W/kg

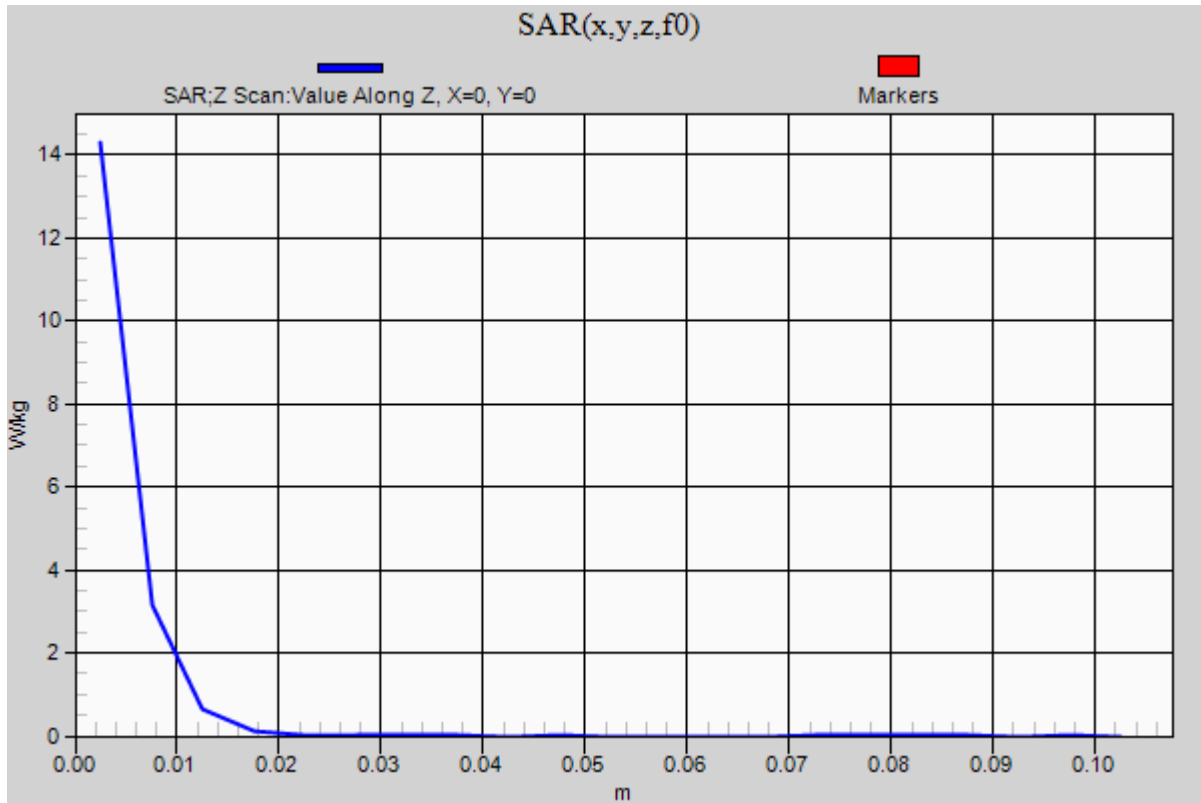

### 20130213 SystemPerformanceCheck-D5GHzV2 SN 1138

Frequency: 5600 MHz; Duty Cycle: 1:1; Room Ambient Temperature: 24.0°C; Liquid Temperature: 23.0°C

Medium parameters used:  $f = 5600 \text{ MHz}$ ;  $\sigma = 5.935 \text{ S/m}$ ;  $\epsilon_r = 46.416$ ;  $\rho = 1000 \text{ kg/m}^3$

DASY5 Configuration:

- Area Scan Setting: Find Secondary Maximum Within: 2.0 dB and with a peak SAR value greater than 0.0012W/kg
- Electronics: DAE4 Sn1239; Calibrated: 6/6/2012
- Probe: EX3DV4 - SN3773; ConvF(3.46, 3.46); Calibrated: 3/14/2012;
- Sensor-Surface: 1.4mm (Mechanical Surface Detection (Locations From Previous Scan Used)), Sensor-Surface: 1.4mm (Mechanical Surface Detection)
- Phantom: ELI v5.0 (A); Type: QDOVA001BB; Serial: 1117

**Body/5.6 GHz, Pin=100mW/Area Scan (7x7x1):** Measurement grid: dx=10mm, dy=10mm

Maximum value of SAR (measured) = 22.4 W/kg

**Body/5.6 GHz, Pin=100mW/Zoom Scan (8x8x7)/Cube 0:** Measurement grid: dx=4mm, dy=4mm,

dz=1.4mm

Reference Value = 54.484 V/m; Power Drift = -0.05 dB

Peak SAR (extrapolated) = 38.0 W/kg

**SAR(1 g) = 8.51 W/kg; SAR(10 g) = 2.36 W/kg**

Maximum value of SAR (measured) = 20.5 W/kg

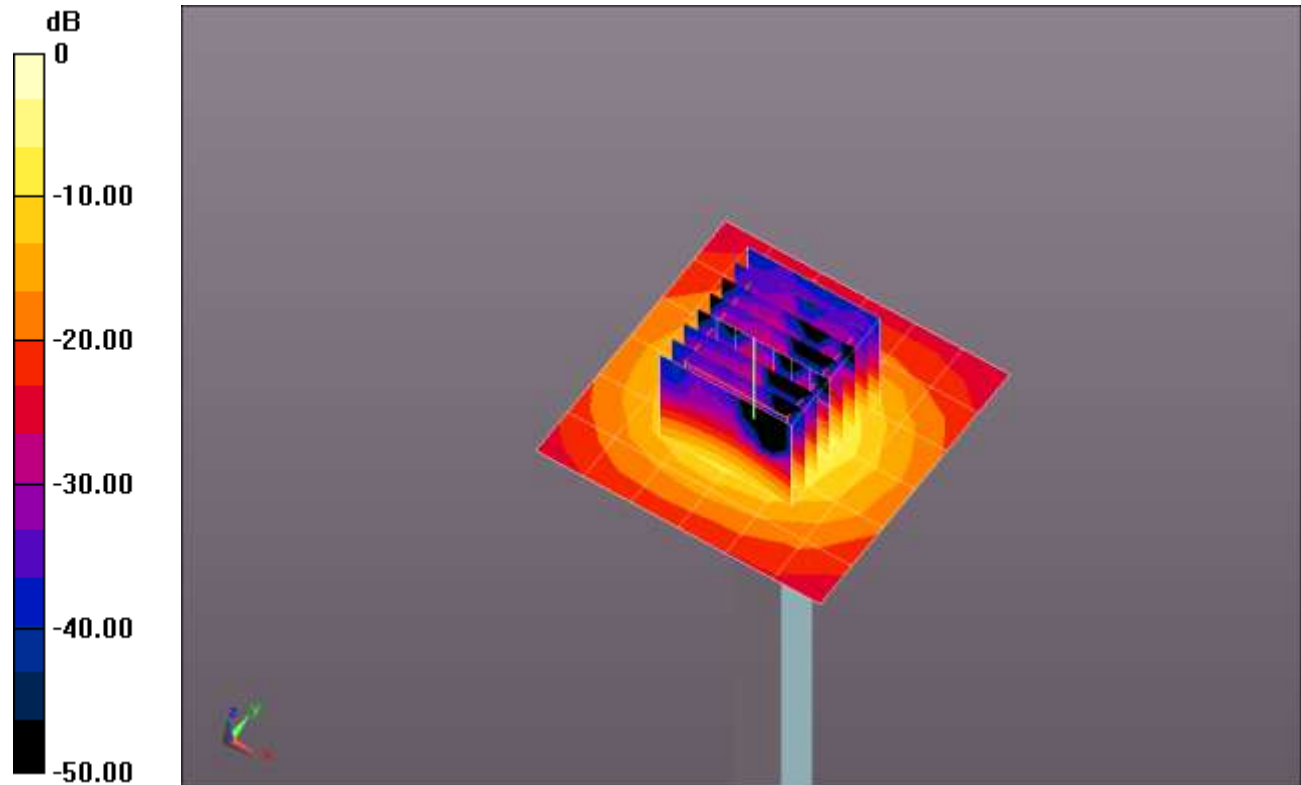

0 dB = 20.5 W/kg = 13.12 dBW/kg

### 20130213 SystemPerformanceCheck-D5GHzV2 SN 1138

Frequency: 5600 MHz; Duty Cycle: 1:1

**Body/5.6 GHz, Pin=100mW/Z Scan (1x1x21):** Measurement grid: dx=20mm, dy=20mm, dz=5mm  
Maximum value of SAR (measured) = 15.2 W/kg

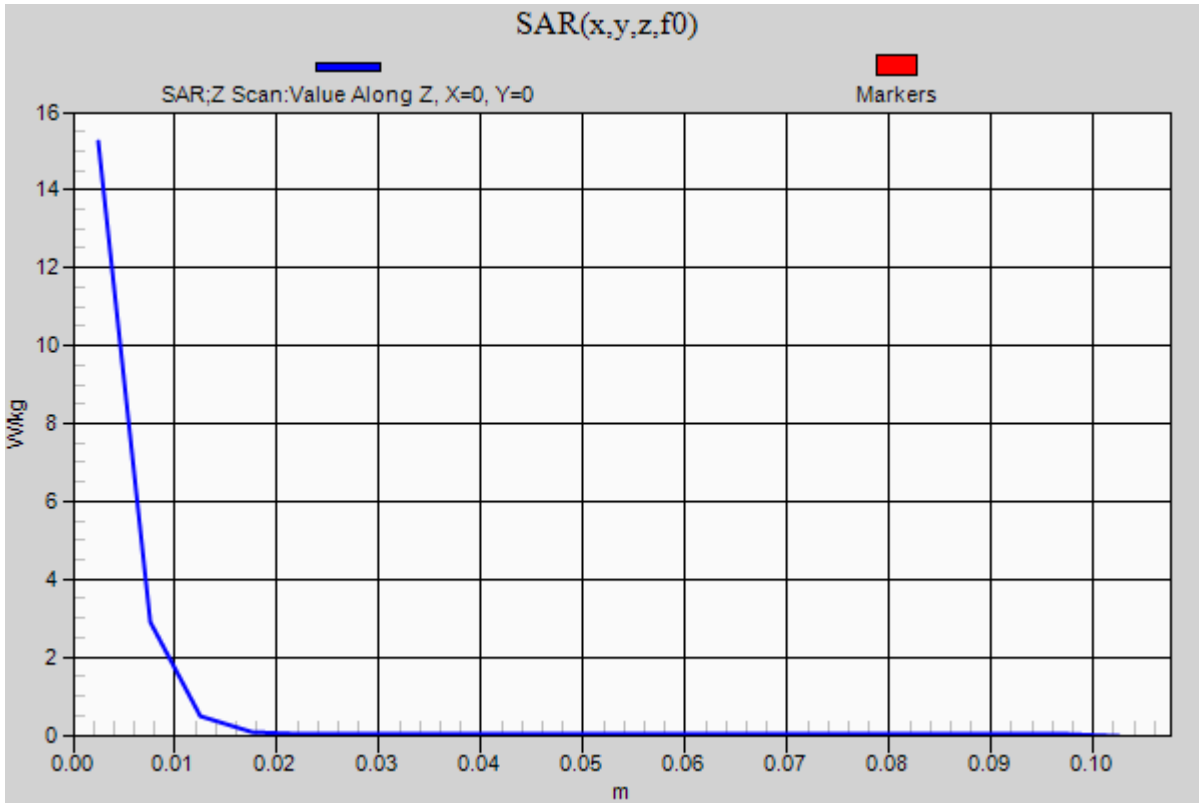

## 20130213 SystemPerformanceCheck-D5GHzV2 SN 1138

Frequency: 5800 MHz; Duty Cycle: 1:1; Room Ambient Temperature: 24.0°C; Liquid Temperature: 23.0°C

Medium parameters used:  $f = 5800 \text{ MHz}$ ;  $\sigma = 6.212 \text{ S/m}$ ;  $\epsilon_r = 46.088$ ;  $\rho = 1000 \text{ kg/m}^3$

DASY5 Configuration:

- Area Scan Setting: Find Secondary Maximum Within: 2.0 dB and with a peak SAR value greater than 0.0012W/kg
- Electronics: DAE4 Sn1239; Calibrated: 6/6/2012
- Probe: EX3DV4 - SN3773; ConvF(3.57, 3.57, 3.57); Calibrated: 3/14/2012;
- Sensor-Surface: 1.4mm (Mechanical Surface Detection (Locations From Previous Scan Used)), Sensor-Surface: 1.4mm (Mechanical Surface Detection)
- Phantom: ELI v5.0 (A); Type: QDOVA001BB; Serial: 1117

**Body/5.8 GHz, Pin=100mW/Area Scan (7x7x1):** Measurement grid: dx=10mm, dy=10mm

Maximum value of SAR (measured) = 20.0 W/kg

**Body/5.8 GHz, Pin=100mW/Zoom Scan (8x8x7)/Cube 0:** Measurement grid: dx=4mm, dy=4mm, dz=1.4mm

Reference Value = 51.188 V/m; Power Drift = -0.07 dB

Peak SAR (extrapolated) = 33.0 W/kg

**SAR(1 g) = 7.56 W/kg; SAR(10 g) = 2.11 W/kg**

Maximum value of SAR (measured) = 18.2 W/kg

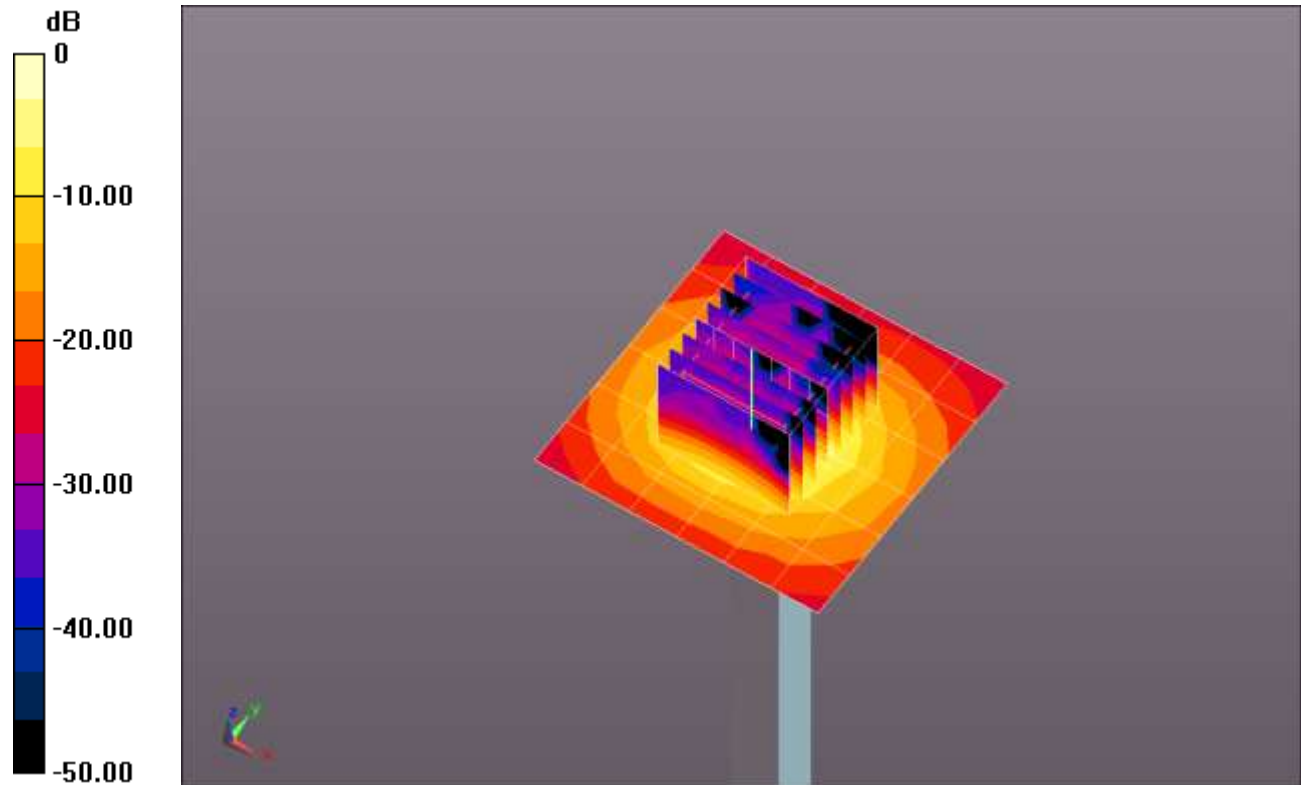

0 dB = 18.2 W/kg = 12.60 dBW/kg

### 20130213 SystemPerformanceCheck-D5GHzV2 SN 1138

Frequency: 5800 MHz; Duty Cycle: 1:1

**Body/5.8 GHz, Pin=100mW/Z Scan (1x1x21):** Measurement grid: dx=20mm, dy=20mm, dz=5mm  
Maximum value of SAR (measured) = 13.7 W/kg

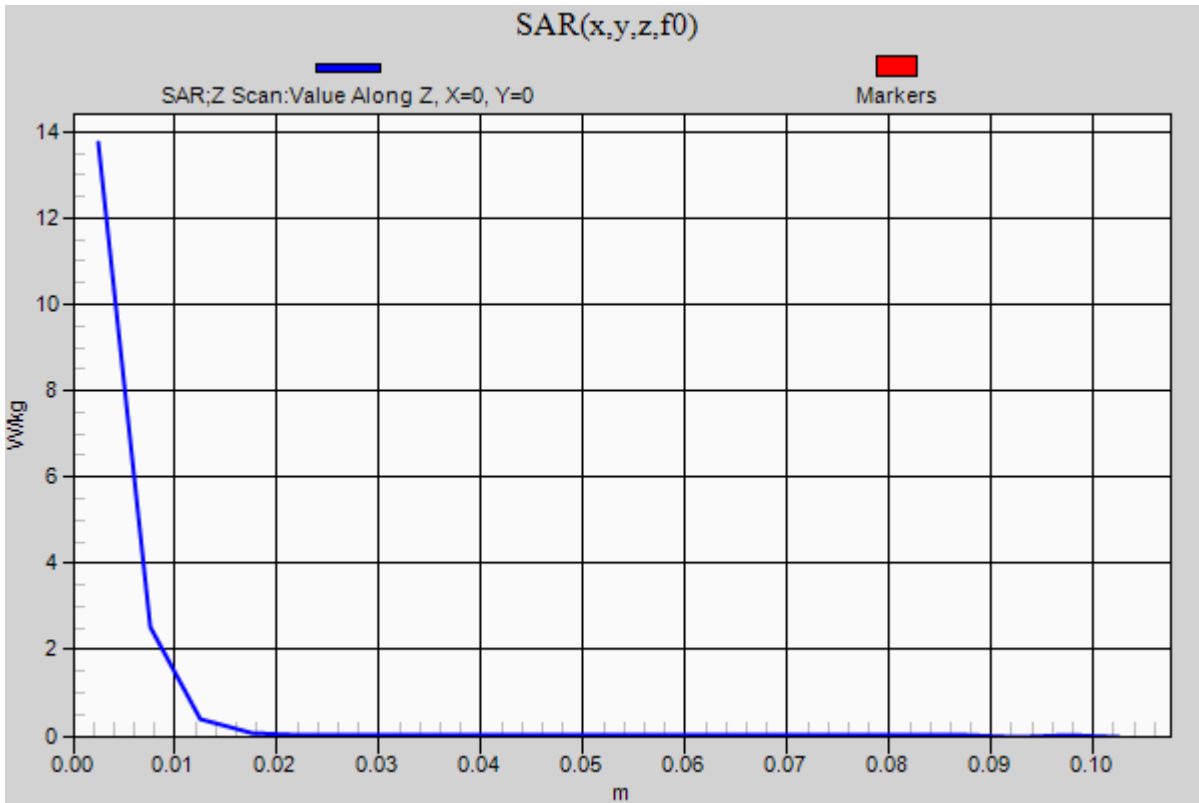

## 20130214 SystemPerformanceCheck-D2450V2 SN 899

Frequency: 2450 MHz; Duty Cycle: 1:1; Room Ambient Temperature: 24.0°C; Liquid Temperature: 23.0°C  
Medium parameters used:  $f = 2450$  MHz;  $\sigma = 1.971$  mho/m;  $\epsilon_r = 50.502$ ;  $\rho = 1000$  kg/m<sup>3</sup>

DASY5 Configuration:

- Area Scan Setting: Find Secondary Maximum Within: 2.0 dB and with a peak SAR value greater than 0.0012W/kg
- Averaged Fast SAR: Polynomial fit
- Electronics: DAE4 Sn1352; Calibrated: 10/8/2012
- Probe: EX3DV4 - SN3885; ConvF(6.8, 6.8, 6.8); Calibrated: 10/9/2012;
- Sensor-Surface: 2.5mm (Mechanical Surface Detection)
- Phantom: ELI v5.0 (B); Type: QDOVA001BB; Serial: 1185

**Body/Pin=100 mW/Area Scan (71x71x1):** Interpolated grid: dx=1.200 mm, dy=1.200 mm

Reference Value = 59.894 V/m; Power Drift = -0.04 dB

**Fast SAR: SAR(1 g) = 5.35 W/kg; SAR(10 g) = 2.31 W/kg**

Maximum value of SAR (interpolated) = 7.81 W/kg

**Body/Pin=100 mW/Zoom Scan (7x7x7)/Cube 0:** Measurement grid: dx=5mm, dy=5mm, dz=5mm

Reference Value = 59.894 V/m; Power Drift = -0.04 dB

Peak SAR (extrapolated) = 11.4 W/kg

**SAR(1 g) = 5.38 W/kg; SAR(10 g) = 2.48 W/kg**

Maximum value of SAR (measured) = 7.68 W/kg

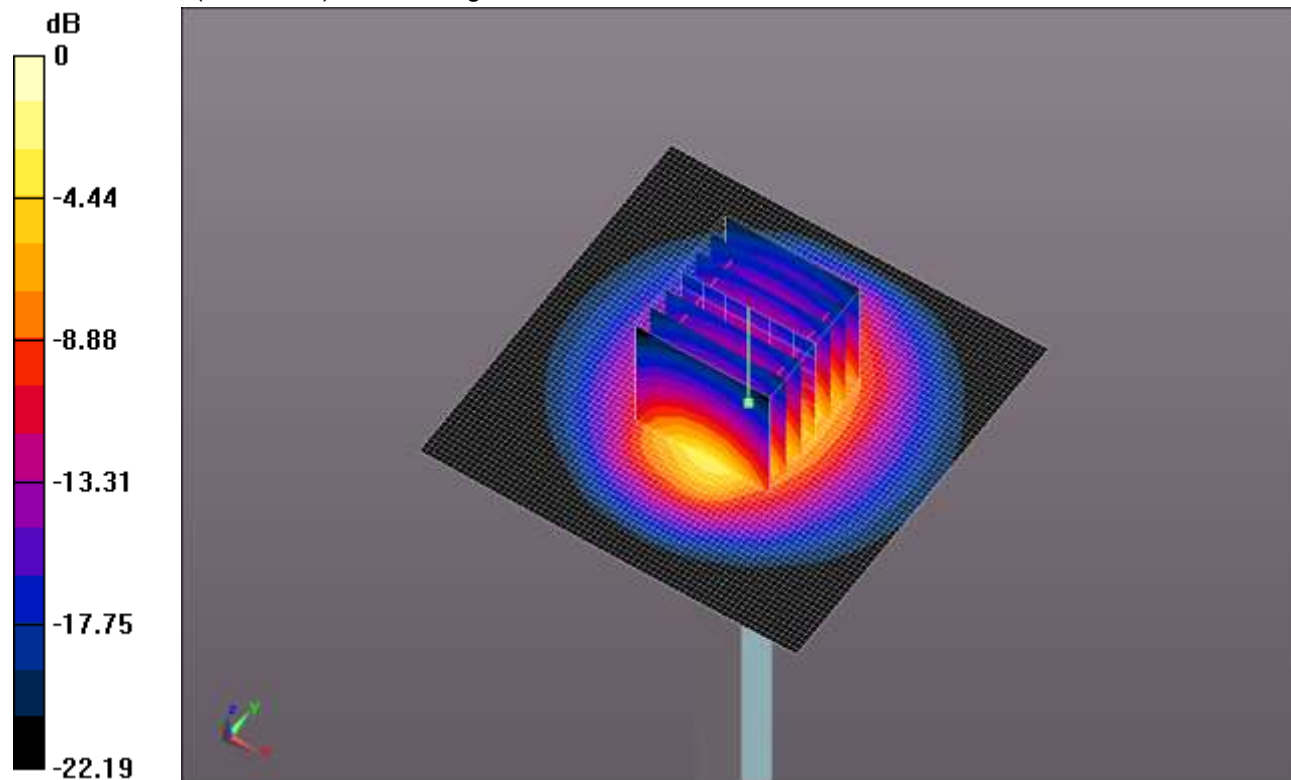

0 dB = 7.68 W/kg = 8.85 dBW/kg

## 20130214 SystemPerformanceCheck-D2450V2 SN 899

Frequency: 2450 MHz; Duty Cycle: 1:1

**Body/Pin=100 mW/Z Scan (1x1x21):** Measurement grid: dx=20mm, dy=20mm, dz=5mm  
Maximum value of SAR (measured) = 7.03 W/kg

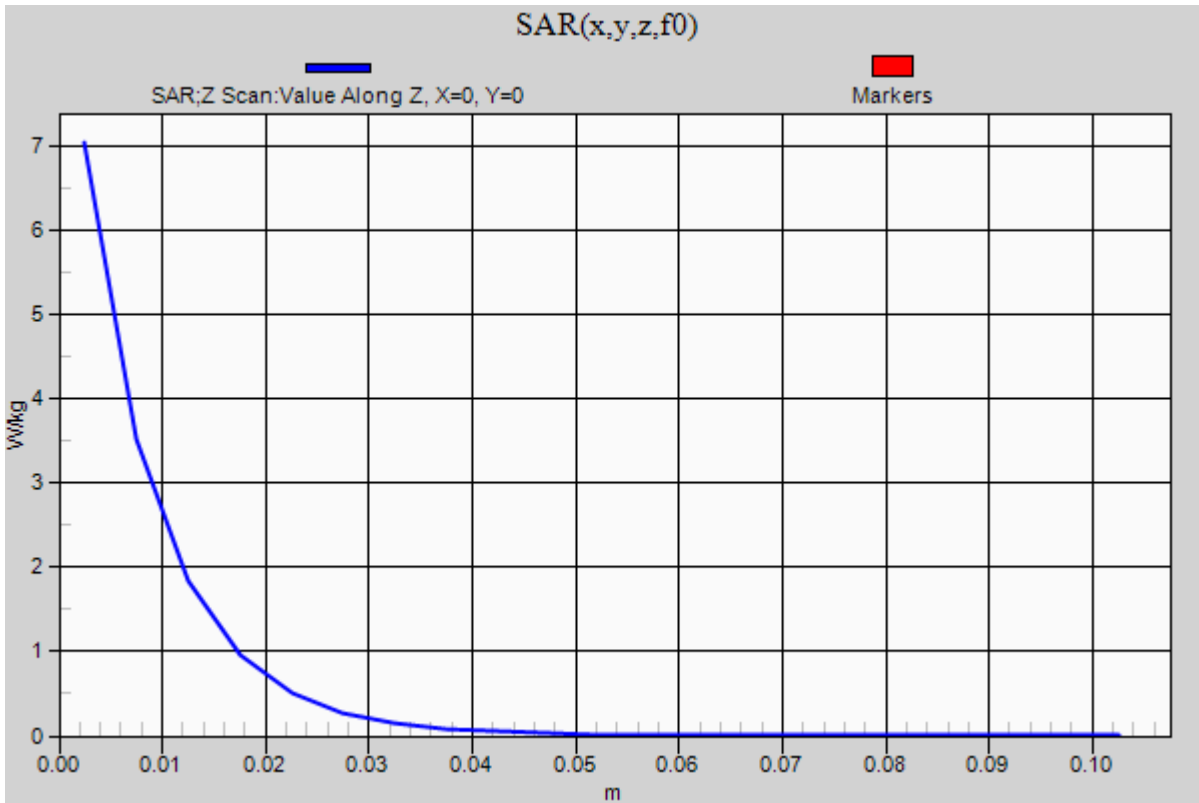

## 20130219 SystemPerformanceCheck-D5GHzV2 SN 1003

Frequency: 5200 MHz; Duty Cycle: 1:1; Room Ambient Temperature: 25.0°C; Liquid Temperature: 24.0°C  
Medium parameters used:  $f = 5200$  MHz;  $\sigma = 5.366$  mho/m;  $\epsilon_r = 48.225$ ;  $\rho = 1000$  kg/m<sup>3</sup>

DASY5 Configuration:

- Area Scan Setting: Find Secondary Maximum Within: 2.0 dB and with a peak SAR value greater than 0.0012W/kg
- Averaged Fast SAR: Polynomial fit
- Electronics: DAE4 Sn1239; Calibrated: 6/6/2012
- Probe: EX3DV4 - SN3773; ConvF(4.15, 4.15, 4.15); Calibrated: 3/14/2012;
- Sensor-Surface: 1.4mm (Mechanical Surface Detection)
- Phantom: ELI v5.0 (A); Type: QDOVA001BB; Serial: 1117

**Body/5.2 GHz, Pin=100mW/Area Scan (61x61x1):** Interpolated grid: dx=1.000 mm, dy=1.000 mm

Reference Value = 51.640 V/m; Power Drift = 0.01 dB

**Fast SAR: SAR(1 g) = 6.69 W/kg; SAR(10 g) = 1.82 W/kg**

Maximum value of SAR (interpolated) = 17.7 W/kg

**Body/5.2 GHz, Pin=100mW/Zoom Scan (8x8x7)/Cube 0:** Measurement grid: dx=4mm, dy=4mm, dz=1.4mm

Reference Value = 51.640 V/m; Power Drift = 0.01 dB

Peak SAR (extrapolated) = 28.9 W/kg

**SAR(1 g) = 7.02 W/kg; SAR(10 g) = 1.98 W/kg**

Maximum value of SAR (measured) = 16.7 W/kg

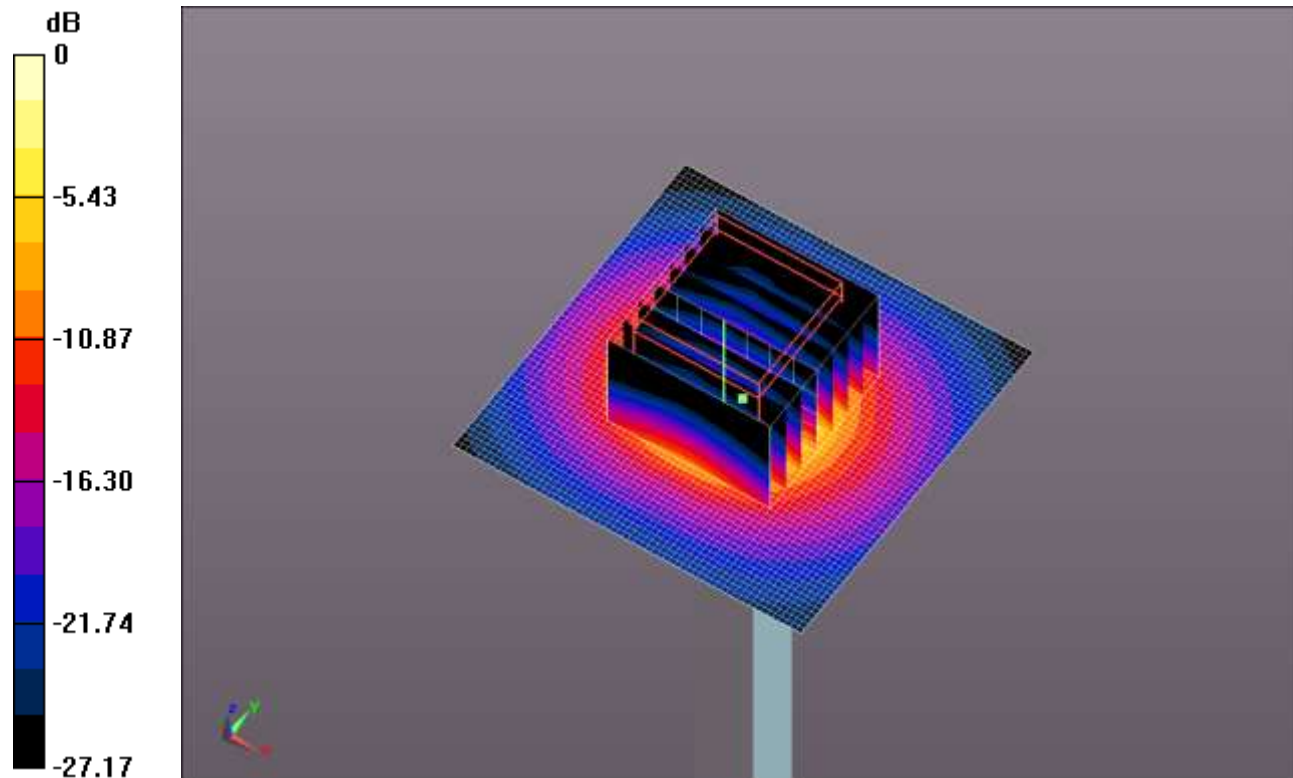

0 dB = 16.7 W/kg = 12.23 dBW/kg

## 20130219 SystemPerformanceCheck-D5GHzV2 SN 1003

Frequency: 5200 MHz; Duty Cycle: 1:1

**Body/5.2 GHz, Pin=100mW/Z Scan (1x1x21):** Measurement grid: dx=20mm, dy=20mm, dz=5mm  
Maximum value of SAR (measured) = 12.6 W/kg

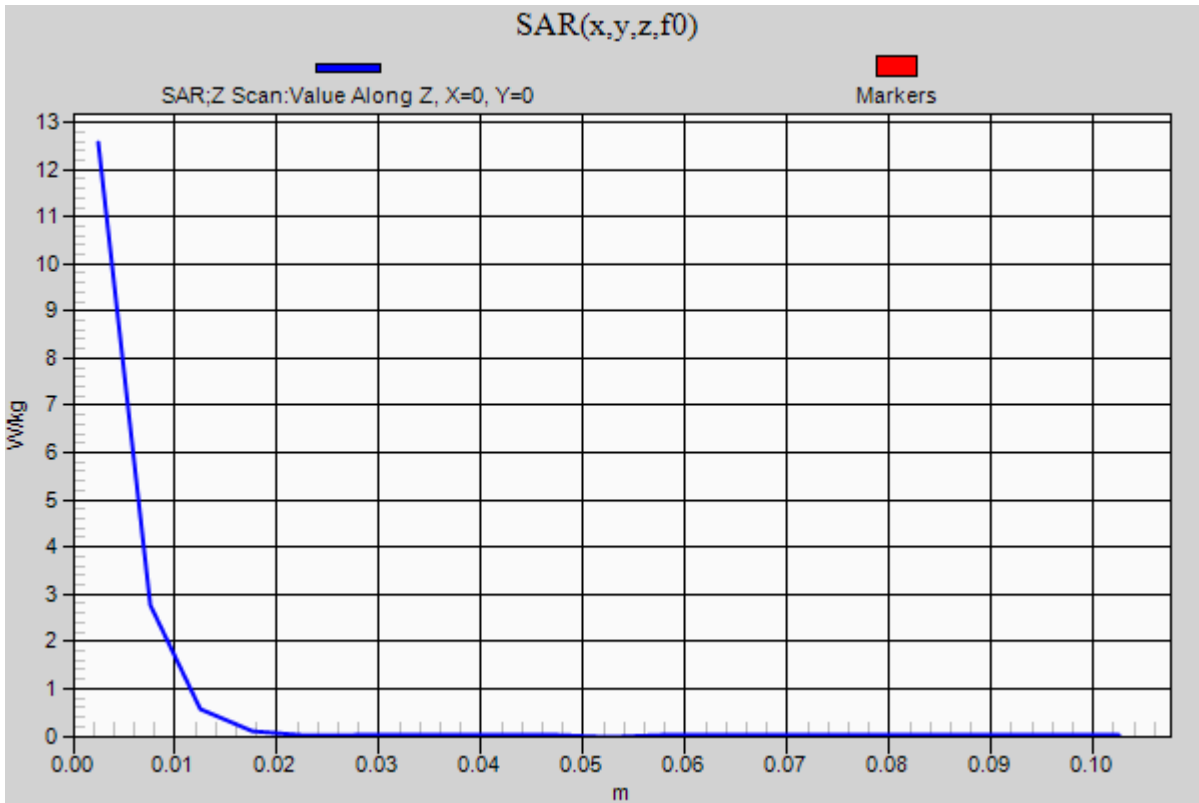

## 20130219 SystemPerformanceCheck-D5GHzV2 SN 1003

Frequency: 5600 MHz; Duty Cycle: 1:1; Room Ambient Temperature: 25.0°C; Liquid Temperature: 24.0°C  
Medium parameters used:  $f = 5600$  MHz;  $\sigma = 5.92$  mho/m;  $\epsilon_r = 47.595$ ;  $\rho = 1000$  kg/m<sup>3</sup>

DASY5 Configuration:

- Area Scan Setting: Find Secondary Maximum Within: 2.0 dB and with a peak SAR value greater than 0.0012W/kg
- Averaged Fast SAR: Polynomial fit
- Electronics: DAE4 Sn1239; Calibrated: 6/6/2012
- Probe: EX3DV4 - SN3773; ConvF(3.46, 3.46, 3.46); Calibrated: 3/14/2012;
- Sensor-Surface: 1.4mm (Mechanical Surface Detection (Locations From Previous Scan Used)), Sensor-Surface: 1.4mm (Mechanical Surface Detection)
- Phantom: ELI v5.0 (A); Type: QDOVA001BB; Serial: 1117

**Body/5.6 GHz, Pin=100mW/Area Scan (61x61x1):** Interpolated grid: dx=1.000 mm, dy=1.000 mm

Reference Value = 52.497 V/m; Power Drift = -0.03 dB

**Fast SAR: SAR(1 g) = 7.33 W/kg; SAR(10 g) = 1.95 W/kg**

Maximum value of SAR (interpolated) = 20.3 W/kg

**Body/5.6 GHz, Pin=100mW/Zoom Scan (8x8x7)/Cube 0:** Measurement grid: dx=4mm, dy=4mm, dz=1.4mm

Reference Value = 52.497 V/m; Power Drift = -0.03 dB

Peak SAR (extrapolated) = 34.7 W/kg

**SAR(1 g) = 7.8 W/kg; SAR(10 g) = 2.15 W/kg**

Maximum value of SAR (measured) = 19.1 W/kg

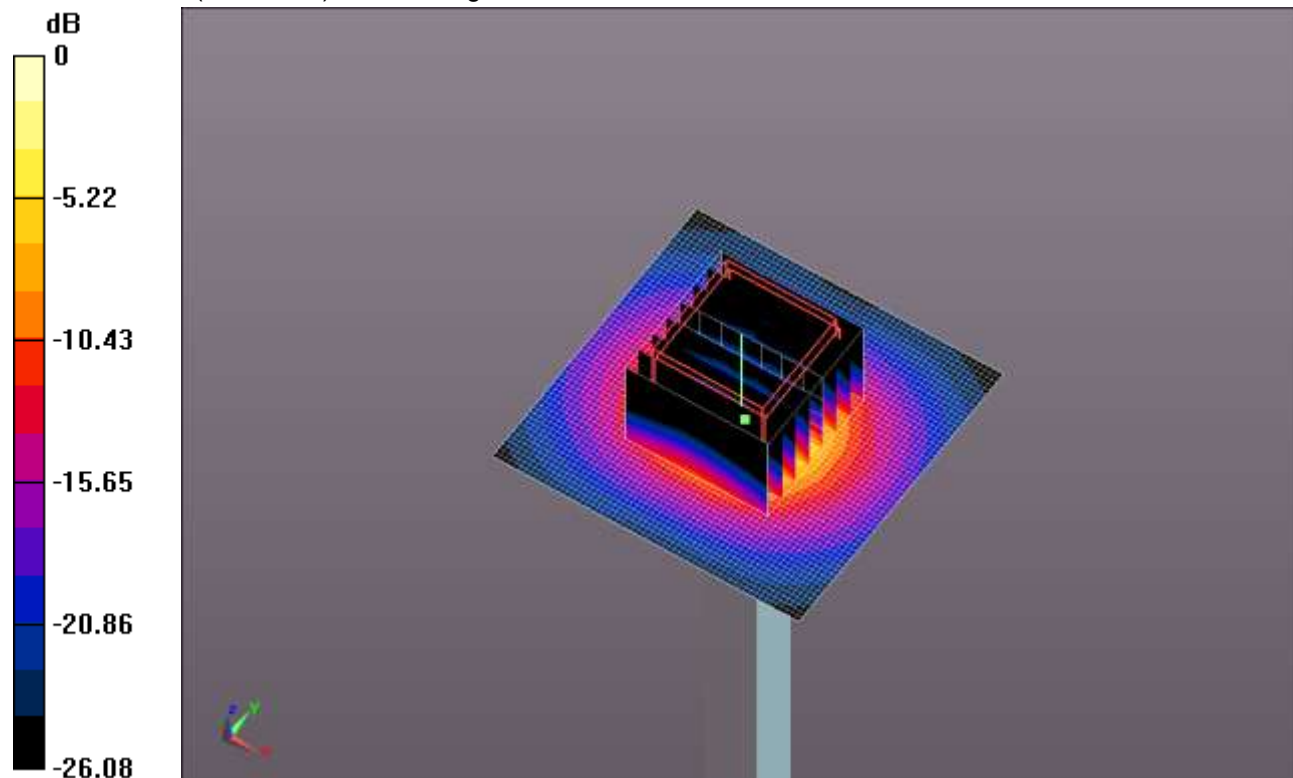

0 dB = 19.1 W/kg = 12.81 dBW/kg

## 20130219 SystemPerformanceCheck-D5GHzV2 SN 1003

Frequency: 5600 MHz; Duty Cycle: 1:1

**Body/5.6 GHz, Pin=100mW/Z Scan (1x1x21):** Measurement grid: dx=20mm, dy=20mm, dz=5mm  
Maximum value of SAR (measured) = 14.1 W/kg

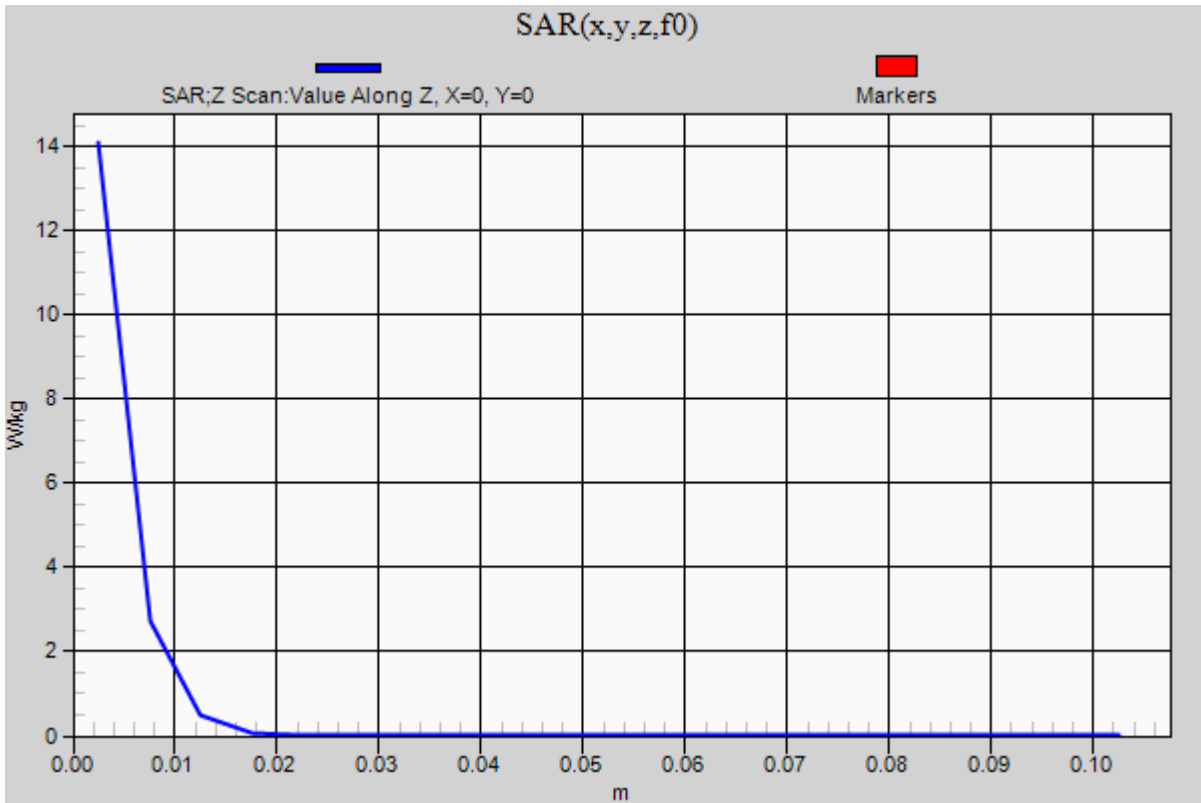

## 20130219 SystemPerformanceCheck-D5GHzV2 SN 1003

Frequency: 5800 MHz; Duty Cycle: 1:1; Room Ambient Temperature: 25.0°C; Liquid Temperature: 24.0°C  
Medium parameters used:  $f = 5800$  MHz;  $\sigma = 6.195$  mho/m;  $\epsilon_r = 47.197$ ;  $\rho = 1000$  kg/m<sup>3</sup>

DASY5 Configuration:

- Area Scan Setting: Find Secondary Maximum Within: 2.0 dB and with a peak SAR value greater than 0.0012W/kg
- Averaged Fast SAR: Polynomial fit
- Electronics: DAE4 Sn1239; Calibrated: 6/6/2012
- Probe: EX3DV4 - SN3773; ConvF(3.57, 3.57, 3.57); Calibrated: 3/14/2012;
- Sensor-Surface: 1.4mm (Mechanical Surface Detection (Locations From Previous Scan Used)), Sensor-Surface: 1.4mm (Mechanical Surface Detection)
- Phantom: ELI v5.0 (A); Type: QDOVA001BB; Serial: 1117

**Body/5.8 GHz, Pin=100mW/Area Scan (61x61x1):** Interpolated grid: dx=1.000 mm, dy=1.000 mm

Reference Value = 50.511 V/m; Power Drift = -0.01 dB

**Fast SAR: SAR(1 g) = 6.72 W/kg; SAR(10 g) = 1.81 W/kg**

Maximum value of SAR (interpolated) = 19.0 W/kg

**Body/5.8 GHz, Pin=100mW/Zoom Scan (8x8x7)/Cube 0:** Measurement grid: dx=4mm, dy=4mm, dz=1.4mm

Reference Value = 50.511 V/m; Power Drift = -0.01 dB

Peak SAR (extrapolated) = 32.4 W/kg

**SAR(1 g) = 7.31 W/kg; SAR(10 g) = 2.03 W/kg**

Maximum value of SAR (measured) = 18.3 W/kg

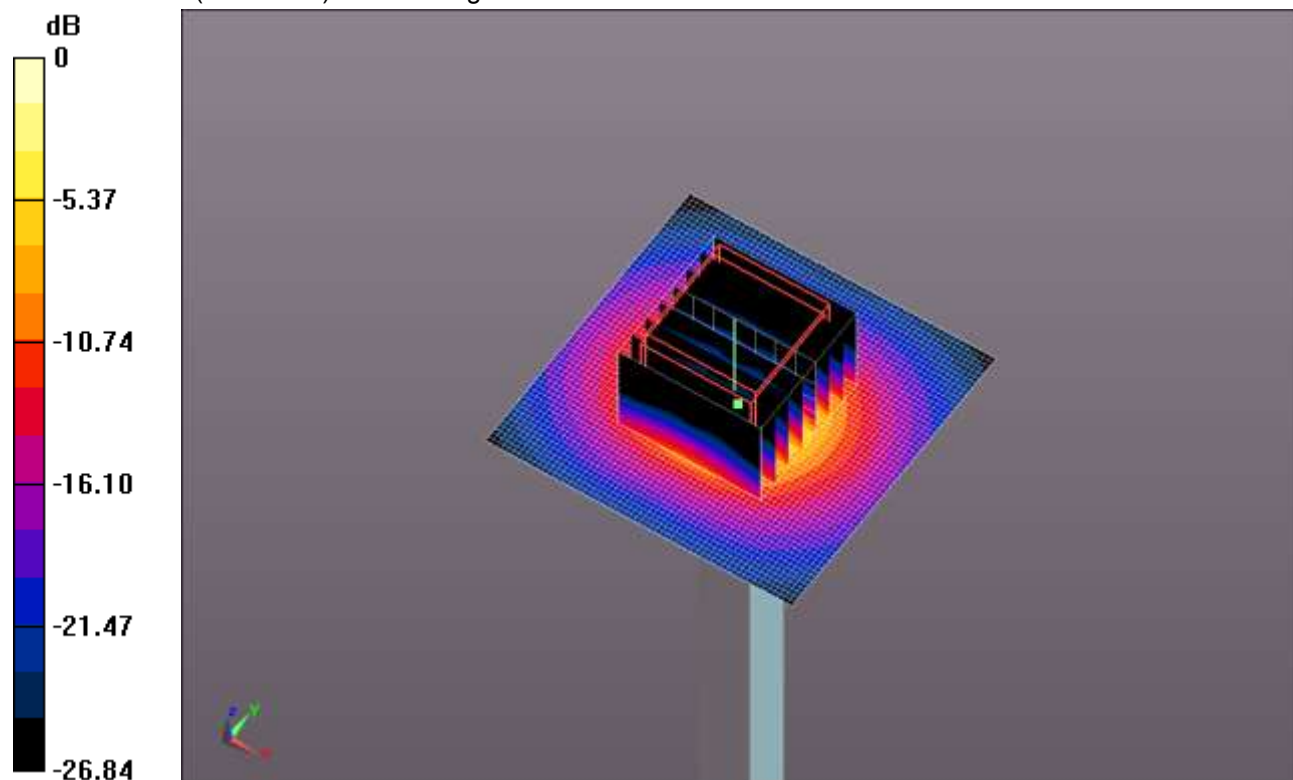

## 20130219 SystemPerformanceCheck-D5GHzV2 SN 1003

Frequency: 5800 MHz; Duty Cycle: 1:1

**Body/5.8 GHz, Pin=100mW/Z Scan (1x1x21):** Measurement grid: dx=20mm, dy=20mm, dz=5mm  
Maximum value of SAR (measured) = 13.3 W/kg

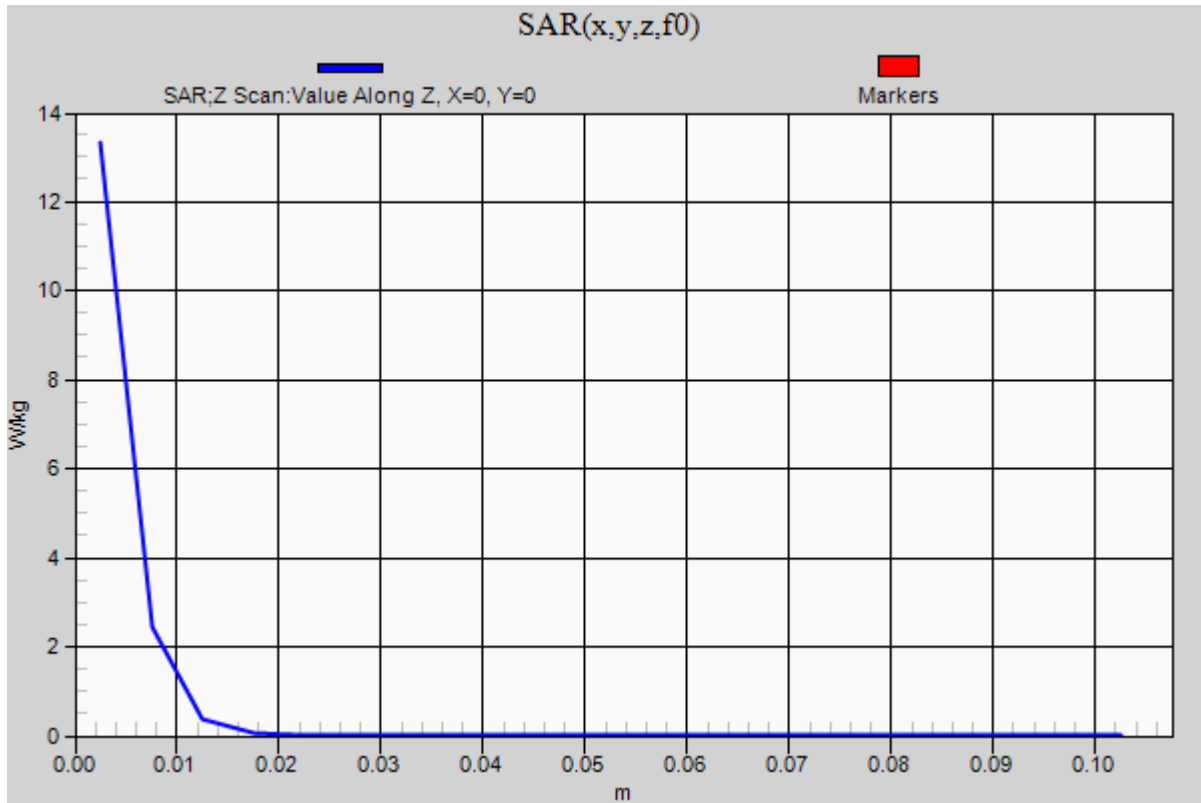

## 20130228 SystemPerformanceCheck-D2450V2 SN 706

Frequency: 2450 MHz; Duty Cycle: 1:1; Room Ambient Temperature: 24.0°C; Liquid Temperature: 23.0°C  
Medium parameters used:  $f = 2450$  MHz;  $\sigma = 1.911$  S/m;  $\epsilon_r = 51.133$ ;  $\rho = 1000$  kg/m<sup>3</sup>

DASY5 Configuration:

- Area Scan Setting: Find Secondary Maximum Within: 2.0 dB and with a peak SAR value greater than 0.0012W/kg
- Electronics: DAE3 Sn427; Calibrated: 1/9/2013
- Probe: EX3DV4 - SN3751; ConvF(6.61, 6.61, 6.61); Calibrated: 11/15/2012;
- Sensor-Surface: 2.5mm (Mechanical Surface Detection)
- Phantom: ELI v5.0 (A); Type: QDOVA001BB; Serial: 1120

**Body/Pin=100 mW/Area Scan (71x71x1):** Interpolated grid: dx=1.200 mm, dy=1.200 mm

Reference Value = 62.787 V/m; Power Drift = 0.06 dB

**Fast SAR: SAR(1 g) = 5.27 W/kg; SAR(10 g) = 2.29 W/kg**

Maximum value of SAR (interpolated) = 7.73 W/kg

**Body/Pin=100 mW/Zoom Scan (7x7x7)/Cube 0:** Measurement grid: dx=5mm, dy=5mm, dz=5mm

Reference Value = 62.787 V/m; Power Drift = 0.06 dB

Peak SAR (extrapolated) = 11.2 W/kg

**SAR(1 g) = 5.33 W/kg; SAR(10 g) = 2.46 W/kg**

Maximum value of SAR (measured) = 7.63 W/kg

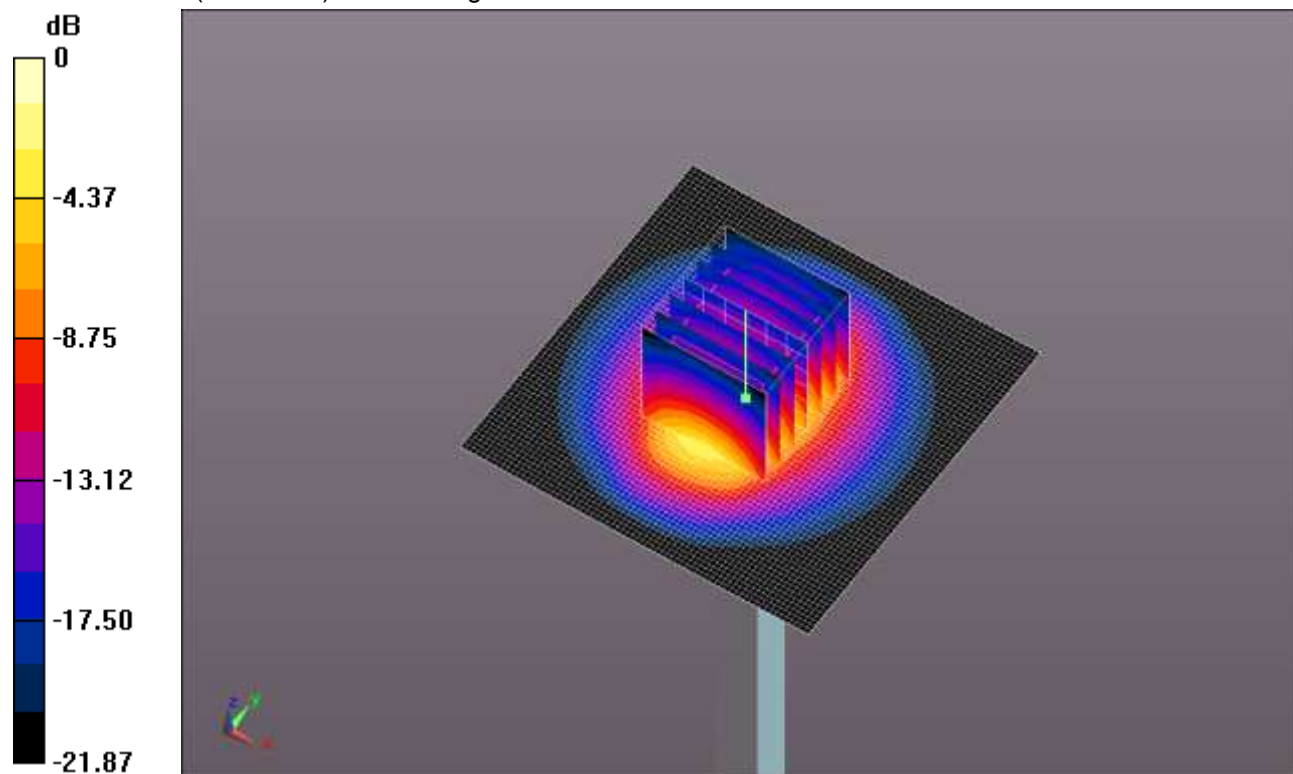

0 dB = 7.63 W/kg = 8.83 dBW/kg

## 20130228 SystemPerformanceCheck-D2450V2 SN 706

Frequency: 2450 MHz; Duty Cycle: 1:1

**Body/Pin=100 mW/Z Scan (1x1x21):** Measurement grid: dx=20mm, dy=20mm, dz=5mm  
Maximum value of SAR (measured) = 7.50 W/kg

