



FCC TEST REPORT (PART 27)

REPORT NO.: RF120309C18-2 R2
MODEL NO.: FZ-A1BDAAVAM
FCC ID: ACJ9TGFZ-A12
RECEIVED: Mar. 09, 2012
TESTED: Apr. 15 ~ Apr. 18, 2012
ISSUED: Jun. 13, 2012

APPLICANT: Panasonic Corporation of North America

ADDRESS: One Panasonic Way, 4B-8 Secaucus, NJ 07094

ISSUED BY: Bureau Veritas Consumer Products Services
(H.K.) Ltd., Taoyuan Branch

LAB ADDRESS: No. 47, 14th Ling, Chia Pau Vil., Lin Kou Dist.,
New Taipei City, Taiwan, R.O.C.

TEST LOCATION: No. 19, Hwa Ya 2nd Rd, Wen Hwa Tsuen, Kwei
Shan Hsiang, Taoyuan Hsien 333, Taiwan, R.O.C.

This report should not be used by the client to claim product certification, approval, or endorsement by TAF or any government agencies.



This report is for your exclusive use. Any copying or replication of this report to or for any other person or entity, or use of our name or trademark, is permitted only with our prior written permission. This report sets forth our findings solely with respect to the test samples identified herein. The results set forth in this report are not indicative or representative of the quality or characteristics of the lot from which a test sample was taken or any similar or identical product unless specifically and expressly noted. Our report includes all of the tests requested by you and the results thereof based upon the information that you provided to us. You have 60 days from date of issuance of this report to notify us of any material error or omission caused by our negligence, provided, however, that such notice shall be in writing and shall specifically address the issue you wish to raise. A failure to raise such issue within the prescribed time shall constitute your unqualified acceptance of the completeness of this report, the tests conducted and the correctness of the report contents. Unless specific mention, the uncertainty of measurement has been explicitly taken into account to declare the compliance or non-compliance to the specification.

TABLE OF CONTENTS

RELEASE CONTROL RECORD	4
1 CERTIFICATION.....	5
2 SUMMARY OF TEST RESULTS.....	6
2.1 MEASUREMENT UNCERTAINTY	6
2.2 TEST SITE AND INSTRUMENTS.....	7
3 GENERAL INFORMATION	8
3.1 GENERAL DESCRIPTION OF EUT.....	8
3.2 CONFIGURATION OF SYSTEM UNDER TEST.....	9
3.3 DESCRIPTION OF SUPPORT UNITS.....	10
3.4 DESCRIPTION OF TEST MODES.....	11
3.5 GENERAL DESCRIPTION OF APPLIED STANDARDS	12
4 TEST TYPES AND RESULTS.....	13
4.1 OUTPUT POWER MEASUREMENT	13
4.1.1 LIMITS OF OUTPUT POWER MEASUREMENT.....	13
4.1.2 TEST PROCEDURES.....	13
4.1.3 TEST SETUP	14
4.1.4 EUT OPERATING CONDITIONS.....	14
4.1.5 TEST RESULTS.....	15
4.2 FREQUENCY STABILITY MEASUREMENT	17
4.2.1 LIMITS OF FREQUENCY STABILITY MEASUREMENT	17
4.2.2 TEST PROCEDURE	17
4.2.3 TEST SETUP	17
4.2.4 TEST RESULTS.....	18
4.3 OCCUPIED BANDWIDTH MEASUREMENT.....	20
4.3.1 LIMITS OF OCCUPIED BANDWIDTH MEASUREMENT	20
4.3.2 TEST SETUP	20
4.3.3 TEST PROCEDURES.....	20
4.3.4 TEST RESULTS.....	21
4.4 PEAK TO AVERAGE RATIO	23
4.4.1 LIMITS OF PEAK TO AVERAGE RATIO MEASUREMENT	23
4.4.2 TEST SETUP	23
4.4.3 TEST PROCEDURES.....	23
4.4.4 TEST RESULTS.....	24
4.5 BAND EDGE MEASUREMENT	25
4.5.1 LIMITS OF BAND EDGE MEASUREMENT.....	25
4.5.2 TEST SETUP	25
4.5.3 TEST PROCEDURES.....	25
4.5.4 TEST RESULTS.....	26
4.6 CONDUCTED SPURIOUS EMISSIONS.....	27
4.6.1 LIMITS OF CONDUCTED SPURIOUS EMISSIONS MEASUREMENT	27



A D T

4.6.2	TEST PROCEDURE	27
4.6.3	TEST SETUP	27
4.6.4	TEST RESULTS.....	28
4.7	RADIATED EMISSION MEASUREMENT	38
4.7.1	LIMITS OF RADIATED EMISSION MEASUREMENT.....	38
4.7.2	TEST PROCEDURES.....	38
4.7.3	DEVIATION FROM TEST STANDARD	38
4.7.4	TEST SETUP	39
4.7.5	TEST RESULTS.....	40
5	INFORMATION ON THE TESTING LABORATORIES.....	56
6	APPENDIX A – MODIFICATIONS RECORDERS FOR ENGINEERING CHANGES TO THE EUT BY THE LAB	57



A D T

RELEASE CONTROL RECORD

ISSUE NO.	REASON FOR CHANGE	DATE ISSUED
RF120309C18-2	Original release	May 25, 2012
RF120309C18-2 R1	Revised the test instrument information, emission designator, identify test configuration, output power table, 26dBc bandwidth and typing error.	Jun. 06, 2012
RF120309C18-2 R2	Added ERP power for modulation 16QAM.	Jun. 13, 2012



1 CERTIFICATION

PRODUCT: Tablet PC
MODEL NO.: FZ-A1BDAAVAM
BRAND: Panasonic
APPLICANT: Panasonic Corporation of North America
TESTED: Apr. 15 ~ Apr. 18, 2012
TEST SAMPLE: Production Unit
TEST STANDARDS: **FCC Part 27, Subpart C, L**
FCC Part 2
ANSI C63.4-2003

The above equipment (model: FZ-A1BDAAVAM) has been tested by **Bureau Veritas Consumer Products Services (H.K.) Ltd., Taoyuan Branch**, and found compliance with the requirement of the above standards. The test record, data evaluation & Equipment Under Test (EUT) configurations represented herein are true and accurate accounts of the measurements of the sample's EMC characteristics under the conditions specified in this report.

PREPARED BY : Ivonne Wu , **DATE:** Jun. 13, 2012
Ivonne Wu / Senior Specialist

APPROVED BY : Gary Chang , **DATE:** Jun. 13, 2012
Gary Chang / Technical Manager

2 SUMMARY OF TEST RESULTS

The EUT has been tested according to the following specifications:

OPERATING BAND: 776-788 MHz			
STANDARD SECTION	TEST TYPE AND LIMIT	RESULT	REMARK
2.1046 27.50(C)(10)	Maximum Peak Output Power Limit: max. 3 watts e.r.p peak power	PASS	Meet the requirement of limit.
2.1055 27.54	Frequency Stability	PASS	Meet the requirement of limit.
2.1049 27.53(g)	Occupied Bandwidth	PASS	Meet the requirement of limit.
27.50(d)(5)	Peak to average ratio	PASS	Meet the requirement of limit.
27.53(g)	Band Edge Measurements	PASS	Meet the requirement of limit.
2.1051 27.53(g)	Conducted Spurious Emissions	PASS	Meet the requirement of limit.
2.1053 27.53(g)	Radiated Spurious Emissions	PASS	Meet the requirement of limit. Minimum passing margin is -17.38dB at 1564.00MHz.

2.1 MEASUREMENT UNCERTAINTY

Where relevant, the following measurement uncertainty levels have been estimated for tests performed on the EUT as specified in CISPR 16-4-2:

MEASUREMENT	FREQUENCY	UNCERTAINTY
Conducted emissions	9kHz~30MHz	2.44 dB
Radiated emissions	30MHz ~ 200MHz	2.93 dB
	200MHz ~1000MHz	2.95 dB
	1GHz ~ 18GHz	2.26 dB
	18GHz ~ 40GHz	1.94 dB

This uncertainty represents an expanded uncertainty expressed at approximately the 95% confidence level using a coverage factor of k=2.

2.2 TEST SITE AND INSTRUMENTS

DESCRIPTION & MANUFACTURER	MODEL NO.	SERIAL NO.	DATE OF CALIBRATION	DUE DATE OF CALIBRATION
Test Receiver Agilent	N9038A	MY51210203	Dec. 22, 2011	Dec. 21, 2012
Spectrum Analyzer ROHDE & SCHWARZ	FSU43	101261	Dec. 21, 2011	Dec. 20, 2012
BILOG Antenna SCHWARZBECK	VULB9168	9168-472	Dec. 20, 2011	Dec. 19, 2012
HORN Antenna SCHWARZBECK	BBHA 9120 D	9120D-969	Dec. 20, 2011	Dec. 19, 2012
HORN Antenna SCHWARZBECK	BBHA 9170	9170-480	Dec. 20, 2011	Dec. 19, 2012
Preamplifier EMCI	EMC 012645	980115	Dec. 30, 2011	Dec. 29, 2012
Preamplifier EMCI	EMC 330H	980112	Dec. 30, 2011	Dec. 29, 2012
RF signal cable HUBER+SUHNNER	SUCOFLEX 104	309219/4	Oct. 21, 2011	Oct. 20, 2012
RF signal cable HUBER+SUHNNER	SUCOFLEX 104	250130/4	Jan. 02, 2012	Jan. 01, 2013
RF signal cable Worken	RG-213	NA	Jan. 02, 2012	Jan. 01, 2013
Software	E3 6.120103	NA	NA	NA
Antenna Tower MF	MFA-440H	NA	NA	NA
Turn Table MF	MFT-201SS	NA	NA	NA
Antenna Tower & Turn Table Controller MF	MF-7802	NA	NA	NA
Mini-Circuits Power Splitter	ZN2PD-9G	NA	May 25, 2011	May 24, 2012
JFW 20dB attenuation	50HF-020-SMA	NA	NA	NA
Radio Communication Analyzer	MT8820C	6201010284	Aug. 01, 2011	Jul. 31, 2012

- NOTE:**
1. The calibration interval of the above test instruments is 12 months and the calibrations are traceable to NML/ROC and NIST/USA.
 2. The test was performed in HwaYa Chamber 9.
 3. The horn antenna and HP preamplifier (model: 8449B) are used only for the measurement of emission frequency above 1GHz if tested.
 4. The FCC Site Registration No. is 460141.
 5. The IC Site Registration No. is IC 7450F-4.

3 GENERAL INFORMATION

3.1 GENERAL DESCRIPTION OF EUT

PRODUCT	Tablet PC	
MODEL NO.	FZ-A1BDAAVAM	
POWER SUPPLY	12Vdc (adapter) 7.4Vdc (battery)	
MODULATION TECHNOLOGY	LTE Band 13	QPSK, 16QAM
FREQUENCY RANGE	LTE Band 13 Channel Bandwidth: 5MHz	779.5 ~784.5MHz
	LTE Band 13 Channel Bandwidth: 10MHz	782MHz
MAX. ERP POWER (W)	LTE Band 13 Channel Bandwidth: 5MHz	QPSK: 0.18W 16QAM: 0.17W
	LTE Band 13 Channel Bandwidth: 10MHz	QPSK: 0.18W 16QAM: 0.14W
EMISSION DESIGNATOR	Channel Bandwidth: 5MHz	QPSK: 4M51G7D 16QAM: 4M50W7D
	Channel Bandwidth: 10MHz	QPSK: 9M00G7D 16QAM: 8M91W7D
CATEGORY	LTE: 3	
ANTENNA TYPE	Fixed Internal antenna with 0.57 dBi gain	
DATA CABLE	NA	
I/O PORTS	Refer to Note as below	
ACCESSORY DEVICES	Refer to Note as below	

NOTE:

1. The EUT contains the following accessories.

AC Adapter	Brand Name	JRC
	Model Name	NJD-9370
	Power Rating	I/P:100-240Vac, 0.5A ~ 0.3A, 50/60Hz; O/P: 12Vdc, 2.0A
	DC Power Cord Type	0.7 meter non-shielded cable without ferrite core
Battery	Brand Name	SANYO
	Model Name	2UF484462-3-T0775
	Power Rating	7.4Vdc
	Type	Li-ion
LCD Panel	Brand Name	Hannstar
	Model Name	HSD100PXN1
Main Camera	Brand Name	D-Max Technology
	Model Name	HAC-001502-W1A
2nd Camera	Brand Name	D-Max Technology
	Model Name	HAC-002103-W1A

2. The above EUT information is declared by manufacturer and for more detailed features description, please refer to the manufacturer's specifications or User's Manual.

3.2 CONFIGURATION OF SYSTEM UNDER TEST

<For Radiated Emission Test>

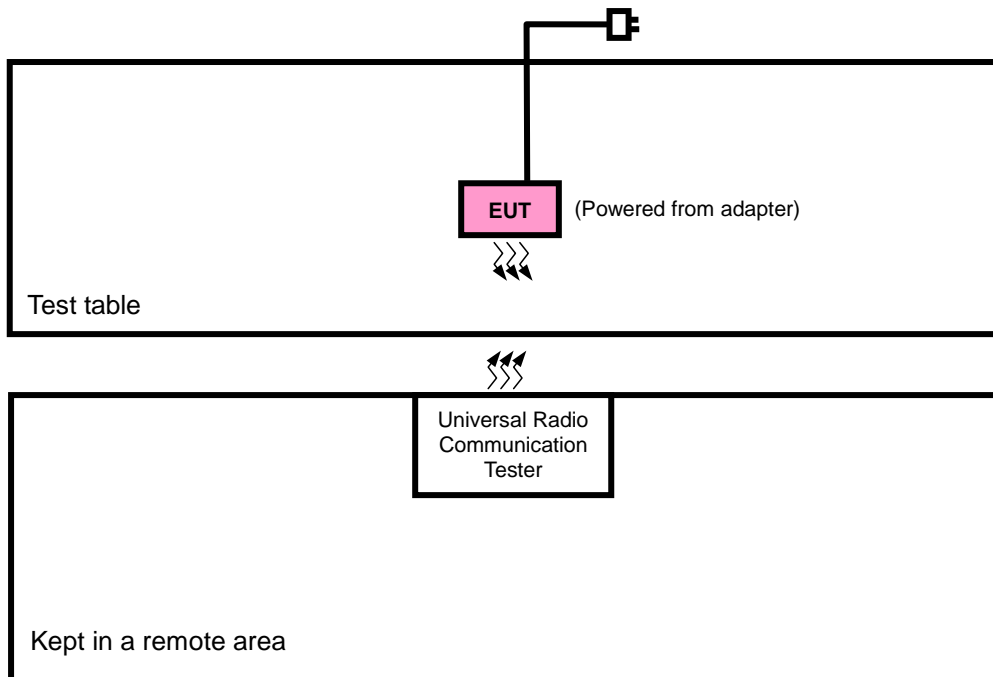

<For Output Power Test>

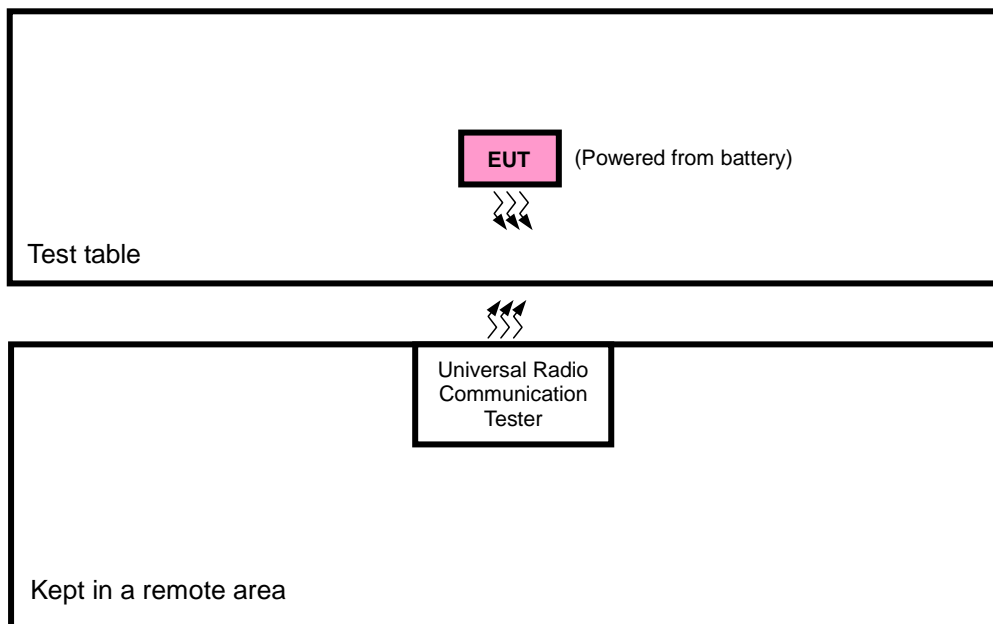

3.3 DESCRIPTION OF SUPPORT UNITS

The EUT has been tested as an independent unit together with other necessary accessories or support units.

3.4 DESCRIPTION OF TEST MODES

Pre-Scan has been conducted to determine the worst-case mode from all possible combinations between available modulations, data rates, XYZ axis and antenna ports. The worst case was found when positioned on X-plane for ERP and Z-axis for radiated emission. Following channel(s) was (were) selected for the final test as listed below:

EUT CONFIGURE MODE	TEST ITEM	AVAILABLE CHANNEL	TESTED CHANNEL	CHANNEL BANDWIDTH
-	ERP	23205 to 23255	23205, 23230, 23255	5MHz
		23230	23230	10MHz
-	FREQUENCY STABILITY	23230	23230	5MHz / 10MHz
-	OCCUPIED BANDWIDTH	23230	23230	5MHz / 10MHz
-	PEAK TO AVERAGE RATIO	23230	23230	5MHz / 10MHz
-	BAND EDGE	23205 to 23255	23205, 23255	5MHz
		23230	23230	10MHz
-	CONDCUDED EMISSION	23230	23230	5MHz / 10MHz
-	RADIATED EMISSION	23230	23230	5MHz / 10MHz

TEST CONDITION:

TEST ITEM	ENVIRONMENTAL CONDITIONS	INPUT POWER	TESTED BY
ERP	25deg. C, 65%RH	7.4Vdc	Phoenix Chen
FREQUENCY STABILITY	25deg. C, 65%RH	7.4Vdc	Phoenix Chen
OCCUPIED BANDWIDTH	25deg. C, 65%RH	7.4Vdc	Phoenix Chen
BAND EDGE	25deg. C, 65%RH	7.4Vdc	Phoenix Chen
CONDCUDED EMISSION	25deg. C, 65%RH	7.4Vdc	Phoenix Chen
RADIATED EMISSION	25deg. C, 65%RH	120Vac, 60Hz	Kay Wu

3.5 GENERAL DESCRIPTION OF APPLIED STANDARDS

The EUT is a RF product. According to the specifications of the manufacturer, it must comply with the requirements of the following standards:

FCC 47 CFR Part 2

FCC 47 CFR Part 27

ANSI C63.4-2003

ANSI/TIA/EIA-603-C 2004

NOTE: All test items have been performed and recorded as per the above standards.

4 TEST TYPES AND RESULTS

4.1 OUTPUT POWER MEASUREMENT

4.1.1 LIMITS OF OUTPUT POWER MEASUREMENT

Portable stations (hand-held devices) operating in the 779-793 MHz band are limited to 3 watts ERP

4.1.2 TEST PROCEDURES

EIRP / ERP MEASUREMENT:

- a. The EUT was set up for the maximum power with LTE link data modulation. The power was measured with R&S Spectrum Analyzer. All measurements were done at 3 channels (low, middle and high operational frequency range). RBW and VBW is 10MHz for LTE.
- b. E.I.R.P power measurement. In the semi-anechoic chamber, EUT placed on the 0.8m height of Turn Table, rotated the table around 360 degrees to search the maximum radiation power and receiver antenna shall be rotated vertical and horizontal polarization and moved height from 1m to 4m to find the maximum polar radiated power. The "Read Value" is the spectrum reading the maximum power value.
- c. The substitution horn antenna is substituted for EUT at the same position and signals generator export the CW signal to the substitution antenna via a TX cable. Rotated the Turn Table and moved receiving antenna to find the maximum radiation power. Adjust output power level of S.G to get a Value of spectrum reading equal to "Read Value" of step a. Record the power level of S.G
- d. $EIRP = \text{Output power level of S.G} - \text{TX cable loss} + \text{Antenna gain of substitution horn}$
- e. $E.R.P = E.I.R.P - 2.15 \text{ dB}$

CONDUCTED POWER MEASUREMENT:

- a. The EUT was set up for the maximum power with LTE link data modulation and link up with simulator.
- b. Set the EUT to transmit under low, middle and high channel and record the power level shown on simulator.

4.1.3 TEST SETUP

EIRP / ERP MEASUREMENT:

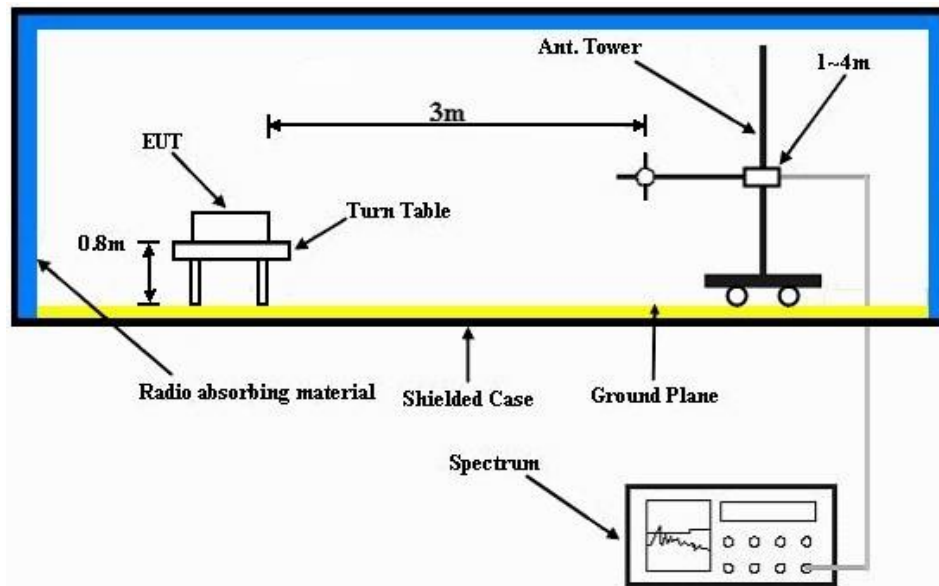

For the actual test configuration, please refer to the attached file (Test Setup Photo).

CONDUCTED POWER MEASUREMENT:

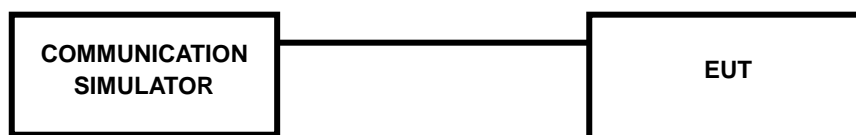

For the actual test configuration, please refer to the attached file (Test Setup Photo).

4.1.4 EUT OPERATING CONDITIONS

- a. The EUT makes a call to the communication simulator.
- b. The communication simulator station system controlled an EUT to export maximum output power under transmission mode and specific channel frequency.

4.1.5 TEST RESULTS

CONDUCTED OUTPUT POWER (dBm)

LTE Band 13								
BW	Modulation	CH	Frequency	RB	RB Offset	MPR	Target	Measured
			(MHz)				Power	Power
5 MHz	QPSK	23205	779.5	1	0	0	23	22.31
		23230	782.0	1	0	0	23	22.42
		23255	784.5	1	0	0	23	22.37
		23205	779.5	1	24	0	23	22.42
		23230	782	1	24	0	23	22.45
		23255	784.5	1	24	0	23	22.39
		23205	779.5	12	6	1	23	21.22
		23230	782	12	6	1	23	21.46
		23255	784.5	12	6	1	23	21.37
		23205	779.5	25	0	1	23	21.26
		23230	782	25	0	1	23	21.33
		23255	784.5	25	0	1	23	21.29
	16QAM	23205	779.5	1	0	1	23	21.6
		23230	782.0	1	0	1	23	21.63
		23255	784.5	1	0	1	23	21.64
		23205	779.5	1	24	1	23	21.62
		23230	782	1	24	1	23	21.77
		23255	784.5	1	24	1	23	21.74
		23205	779.5	12	6	2	23	20.2
		23230	782	12	6	2	23	20.41
23255		784.5	12	6	2	23	20.39	
23205		779.5	25	0	2	23	20.73	
10MHz	QPSK	23230	782	1	0	0	23	22.51
		23230	782	1	49	0	23	22.55
		23230	782	25	12	1	23	21.72
		23230	782	50	0	1	23	21.66
	16QAM	23230	782	1	0	1	23	22.03
		23230	782	1	49	1	23	22.03
		23230	782	25	12	2	23	21.09
		23230	782	50	0	2	23	20.78



A D T

ERP (dBm)

CHANNEL BANDWIDTH: 5MHz QPSK

Plane	Channel	Frequency (MHz)	LVL (dBm)	Correction Factor(dB)	ERP(dBm)	ERP(W)	Polarization (H/V)
X	23205	779.5	-7.72	32.24	22.37	0.17	H
	23230	782.0	-7.53	32.17	22.49	0.18	
	23255	784.5	-7.61	32.11	22.35	0.17	
	23205	779.5	-12.60	32.43	17.68	0.06	V
	23230	782.0	-12.43	32.42	17.84	0.06	
	23255	784.5	-12.40	32.46	17.91	0.06	

CHANNEL BANDWIDTH: 10MHz QPSK

Plane	Channel	Frequency (MHz)	LVL (dBm)	Correction Factor(dB)	ERP(dBm)	ERP(W)	Polarization (H/V)
X	23230	782	-7.58	32.17	22.44	0.18	H
	23230	782	-12.32	32.42	17.95	0.06	V

CHANNEL BANDWIDTH: 5MHz 16QAM

Plane	Channel	Frequency (MHz)	LVL (dBm)	Correction Factor(dB)	ERP(dBm)	ERP(W)	Polarization (H/V)
X	23205	779.5	-7.82	32.24	22.27	0.17	H
	23230	782.0	-8.48	32.17	21.54	0.14	
	23255	784.5	-8.11	32.11	21.85	0.15	
	23205	779.5	-13.29	32.43	16.99	0.05	V
	23230	782.0	-13.52	32.42	16.75	0.05	
	23255	784.5	-13.82	32.46	16.49	0.04	

CHANNEL BANDWIDTH: 10MHz 16QAM

Plane	Channel	Frequency (MHz)	LVL (dBm)	Correction Factor(dB)	ERP(dBm)	ERP(W)	Polarization (H/V)
X	23230	782	-8.66	32.17	21.36	0.14	H
	23230	782	-13.33	32.42	16.94	0.05	V

4.2 FREQUENCY STABILITY MEASUREMENT

4.2.1 LIMITS OF FREQUENCY STABILITY MEASUREMENT

The frequency stability shall be sufficient to ensure that the fundamental emissions stay within the authorized bands of operation.

4.2.2 TEST PROCEDURE

- a. Device is placed at the oven room. The oven room could control the temperatures and humidity. Power warm up is at least 15 min and power applied should perform before recording frequency error.
- b. EUT is connected the external power supply to control the DC input power. The test voltage range is from minimum to maximum working voltage. Each step shall be record the frequency error rate.
- c. The temperature range step is 10 degrees in this test items. All temperature levels shall be hold the $\pm 0.5^{\circ}\text{C}$ during the measurement testing. The each temperature step shall be at least 0.5 hours, consider the EUT could be test under the stability condition.

NOTE: The frequency error was recorded frequency error from the communication simulator.

4.2.3 TEST SETUP

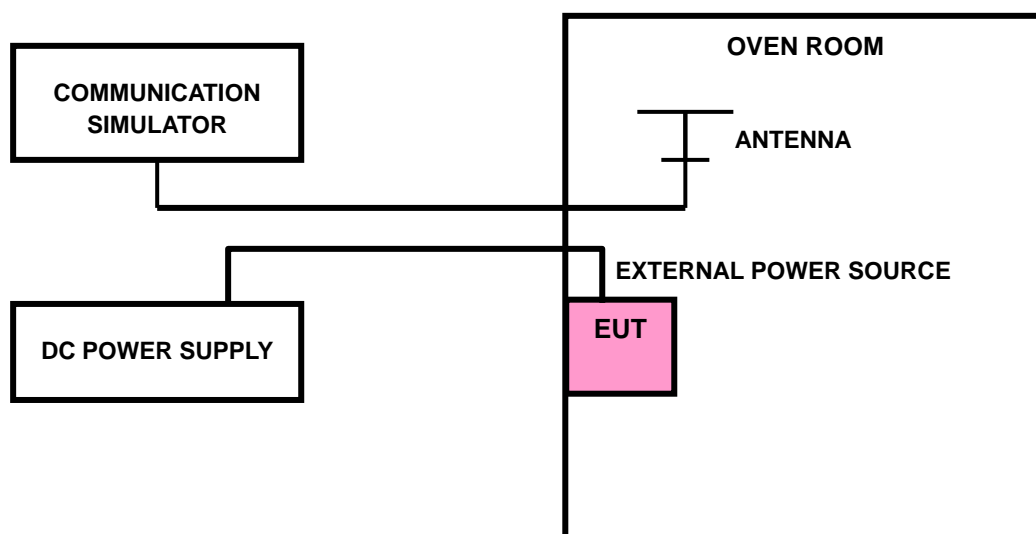

4.2.4 TEST RESULTS

CHANNEL BANDWIDTH: 5MHz

AFC FREQUENCY ERROR vs. VOLTAGE		
VOLTAGE (Volts)	MEASURED ERROR (ppm)	LIMIT (ppm)
7.7	0.05	2.5
7.0	0.04	2.5
8.7	0.04	2.5

NOTE: The applicant defined the normal working voltage of the host equipment is from 7.0Vdc to 8.7Vdc.

AFC FREQUENCY ERROR vs. TEMP.		
TEMP. (°C)	MEASURED ERROR (ppm)	LIMIT (ppm)
-10	-0.06	2.5
0	0.07	2.5
10	0.05	2.5
20	0.04	2.5
30	0.06	2.5
40	0.07	2.5
50	0.07	2.5

CHANNEL BANDWIDTH: 10MHz

AFC FREQUENCY ERROR vs. VOLTAGE		
VOLTAGE (Volts)	MEASURED ERROR (ppm)	LIMIT (ppm)
7.7	0.04	2.5
7.0	0.03	2.5
8.7	-0.04	2.5

NOTE: The applicant defined the normal working voltage of the host equipment is from 7.0Vdc to 8.7Vdc.

AFC FREQUENCY ERROR vs. TEMP.		
TEMP. (°C)	MEASURED ERROR (ppm)	LIMIT (ppm)
-10	0.04	2.5
0	0.03	2.5
10	0.03	2.5
20	0.03	2.5
30	0.03	2.5
40	0.06	2.5
50	0.03	2.5

4.3 OCCUPIED BANDWIDTH MEASUREMENT

4.3.1 LIMITS OF OCCUPIED BANDWIDTH MEASUREMENT

The width of a frequency band such that, below the lower and above the upper frequency limits, the mean powers emitted are each equal to a specified percentage 0.5 %of the total mean power of a given emission.

4.3.2 TEST SETUP

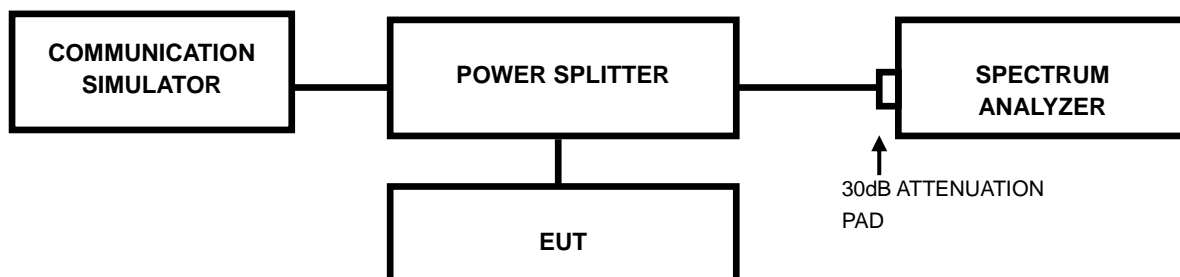

4.3.3 TEST PROCEDURES

- a. The conducted occupied bandwidth used the power splitter via EUT RF power connector between simulation base station and spectrum analyzer.
- b. Use OBW measurement function of Spectrum analyzer to measure 99 % occupied bandwidth.

4.3.4 TEST RESULTS

CHANNEL BANDWIDTH: 5MHz				CHANNEL BANDWIDTH: 10MHz			
CHANNEL	FREQUENCY (MHz)	99% OCCUPIED BANDWIDTH (MHz)		CHANNEL	FREQUENCY (MHz)	99% OCCUPIED BANDWIDTH (MHz)	
		QPSK	16QAM			QPSK	16QAM
23205	779.5	4.490	4.495	23230	782.0	8.998	8.913
23230	782.0	4.493	4.493				
23255	784.5	4.512	4.501				

CHANNEL BANDWIDTH: 5MHz				CHANNEL BANDWIDTH: 10MHz			
CHANNEL	FREQUENCY (MHz)	26dB BANDWIDTH (MHz)		CHANNEL	FREQUENCY (MHz)	26dB BANDWIDTH (MHz)	
		QPSK	16QAM			QPSK	16QAM
23205	779.5	5.117	5.068	23230	782.0	9.946	9.913
23230	782.0	5.091	5.096				
23255	784.5	5.144	5.075				



A D T

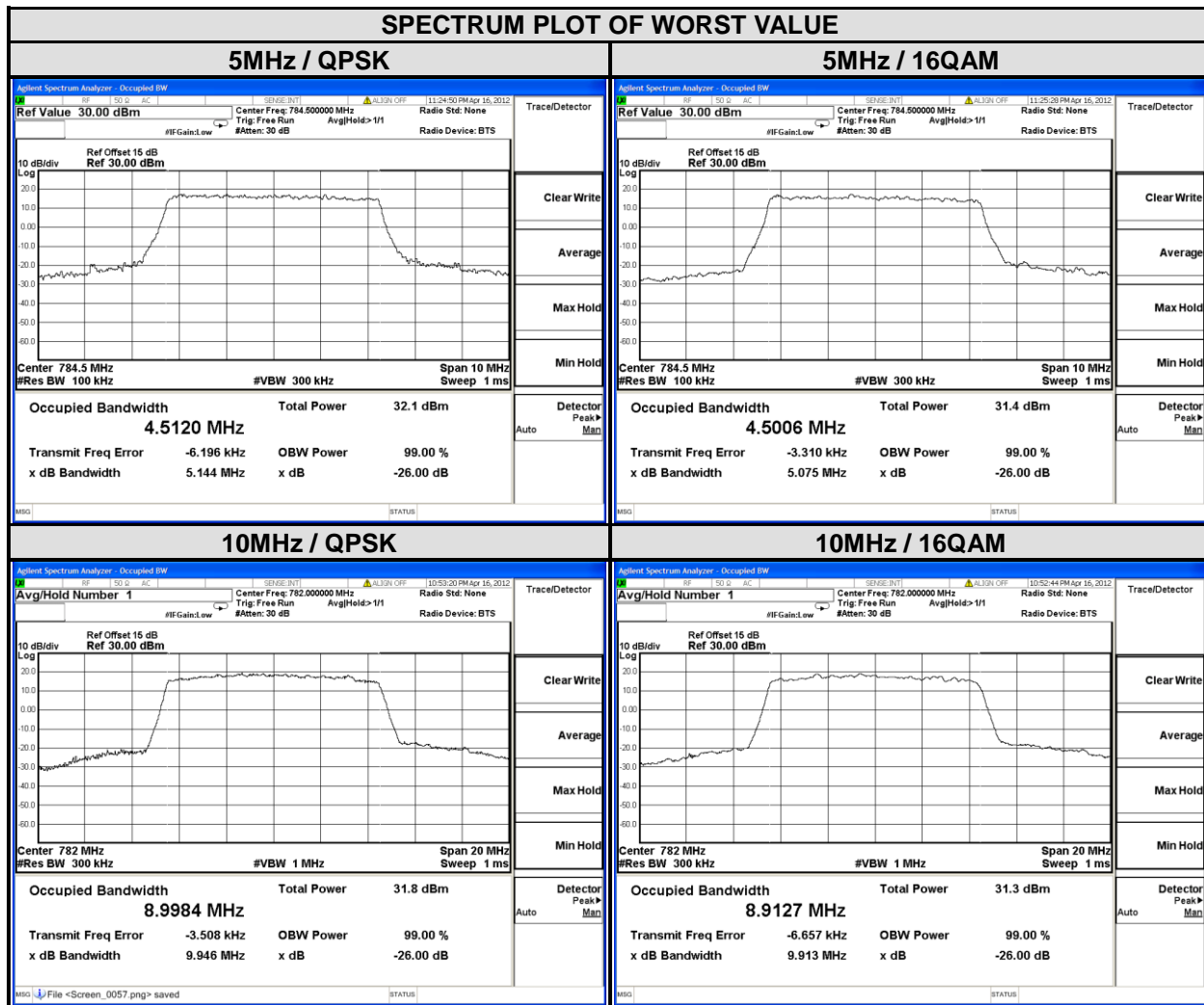

4.4 PEAK TO AVERAGE RATIO

4.4.1 LIMITS OF PEAK TO AVERAGE RATIO MEASUREMENT

In measuring transmissions in this band using an average power technique, the peak to-average ratio (PAR) of the transmission may not exceed 13 dB

4.4.2 TEST SETUP

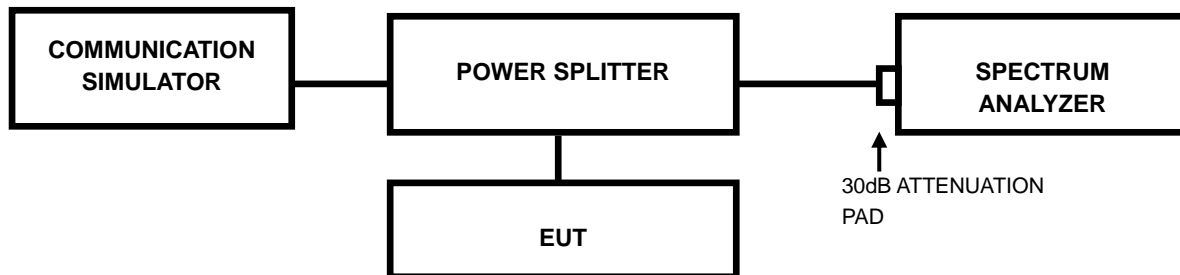

4.4.3 TEST PROCEDURES

1. Set resolution/measurement bandwidth \geq signal's occupied bandwidth;
2. Set the number of counts to a value that stabilizes the measured CCDF curve;
3. Record the maximum PAPR level associated with a probability of 0.1%.

4.4.4 TEST RESULTS

CHANNEL BANDWIDTH: 5MHz			CHANNEL BANDWIDTH: 10MHz		
CHANNEL	FREQUENCY (MHz)	PEAK TO AVERAGE RATIO (dB)	CHANNEL	FREQUENCY (MHz)	PEAK TO AVERAGE RATIO (dB)
		QPSK			QPSK
23205	779.5	4.86	23230	782.0	5.17
23230	782.0	4.83			
23255	784.5	4.61			

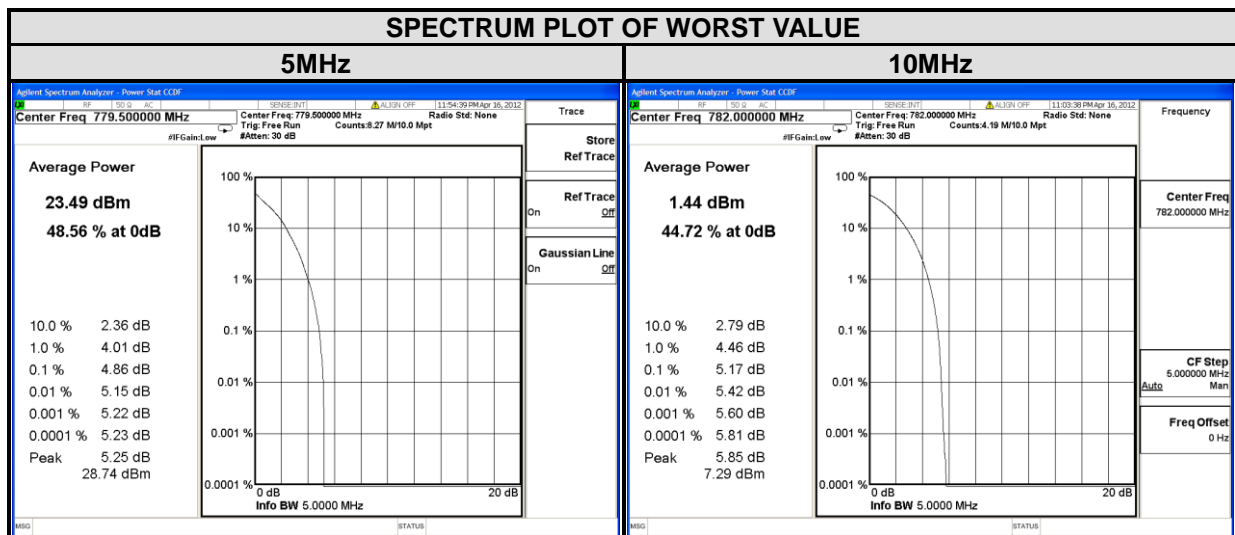

4.5 BAND EDGE MEASUREMENT

4.5.1 LIMITS OF BAND EDGE MEASUREMENT

On any frequency outside the 776–788 MHz band, the power of any emission shall be attenuated outside the band below the transmitter power (P) by at least $43 + 10 \log (P)$ dB.

4.5.2 TEST SETUP

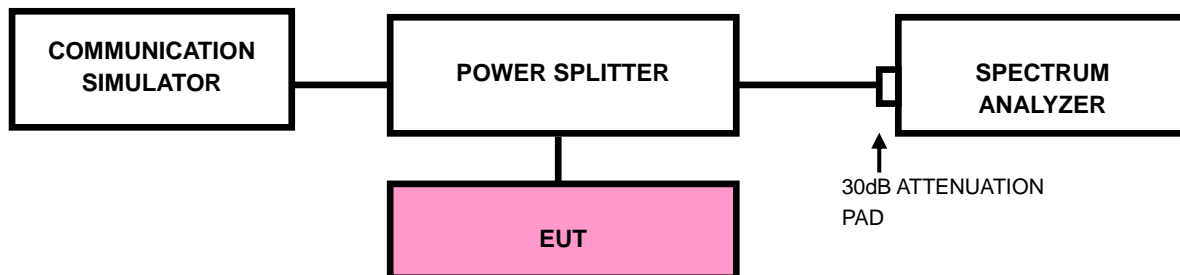

4.5.3 TEST PROCEDURES

- a. The EUT was set up for the maximum peak power with LTE link data modulation. The power was measured with R&S Spectrum Analyzer. All measurements were done at 2 channels (low and high operational frequency range.).
- b. The band edge measurement used the power splitter via EUT RF power connector between simulation base station and spectrum analyzer.
- c. The center frequency of spectrum is the band edge frequency and span is 1 MHz. RB of the spectrum is 100kHz and VB of the spectrum is 300kHz.
- d. Record the max trace plot into the test report.

4.5.4 TEST RESULTS



4.6 CONDUCTED SPURIOUS EMISSIONS

4.6.1 LIMITS OF CONDUCTED SPURIOUS EMISSIONS MEASUREMENT

The power of any emission outside a licensee's frequency block shall be attenuated below the transmitter power (P) by at least $43 + 10 \log_{10}(P)$ dB. The limit of emission equal to -13dBm

On all frequencies between 763–775 MHz and 793–805 MHz, by a factor not less than $65 + 10 \log (P)$ dB in a 6.25 kHz band segment, for mobile and portable stations.

4.6.2 TEST PROCEDURE

- a. The EUT makes a phone call to the communication simulator. All measurements were done at low, middle and high operational frequency range.
- b. Measuring frequency range is from 9 kHz to 9GHz. 20dB attenuation pad is connected with spectrum. RBW=1MHz and VBW=3MHz is used for conducted emission measurement.
- c.

4.6.3 TEST SETUP

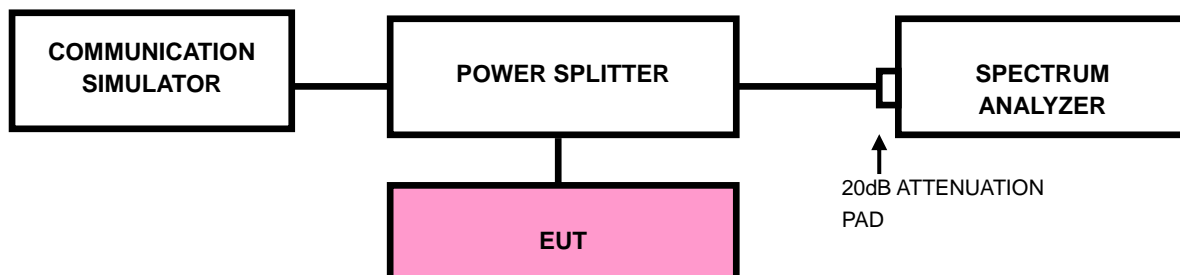



A D T

4.6.4 TEST RESULTS

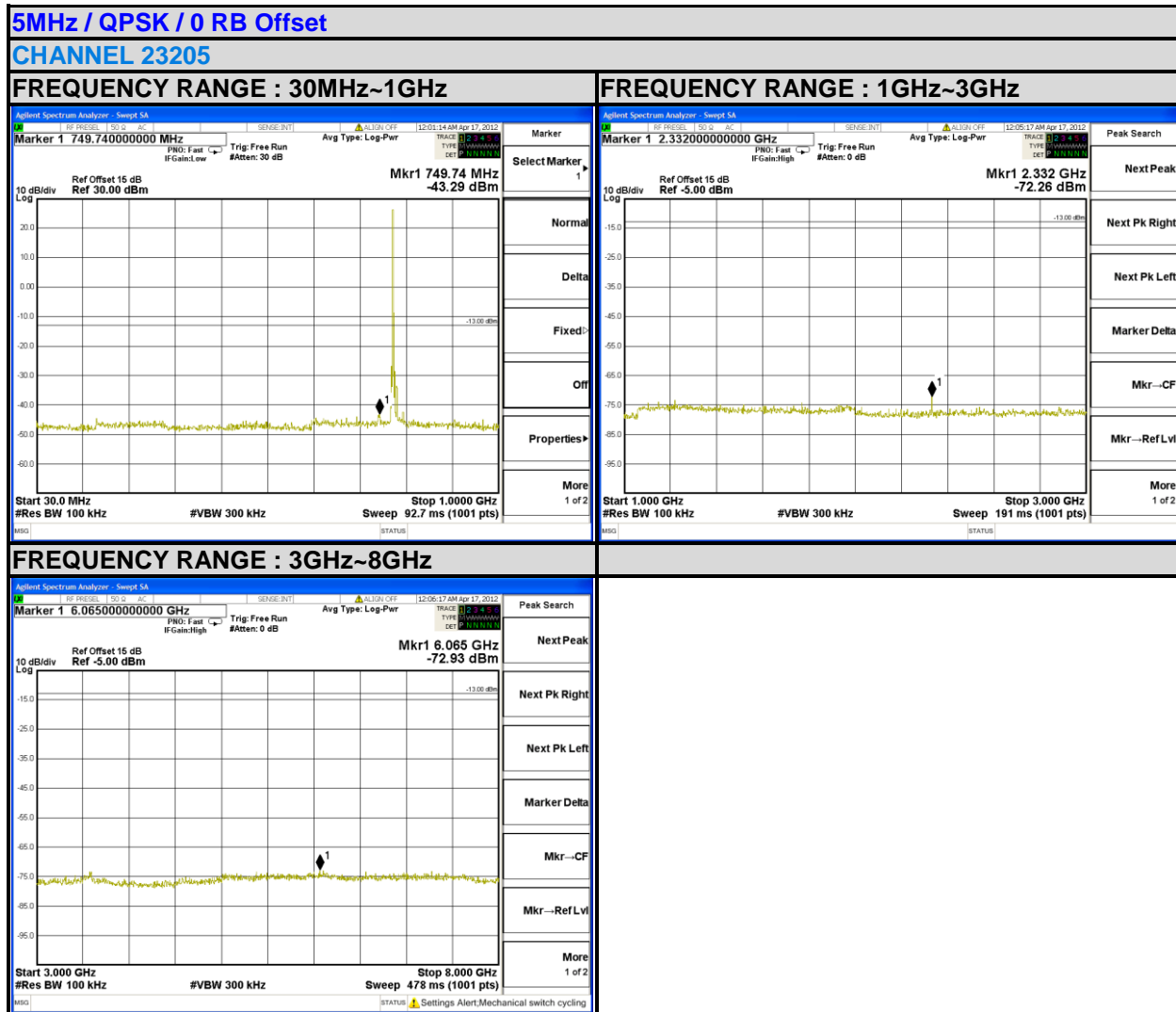



A D T

CHANNEL 23230

FREQUENCY RANGE : 30MHz~1GHz

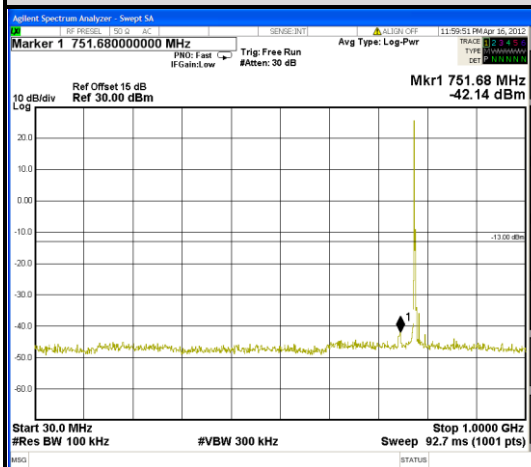

FREQUENCY RANGE : 1GHz~3GHz

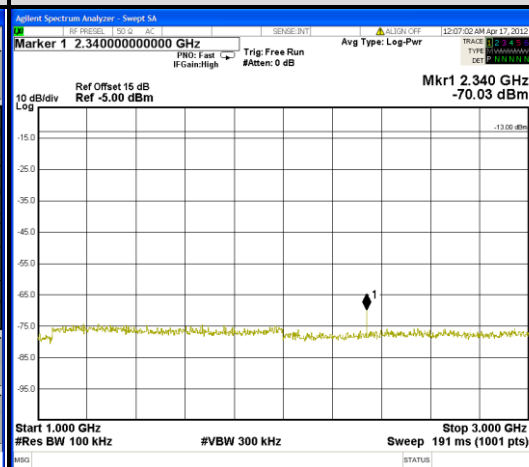

FREQUENCY RANGE : 3GHz~8GHz

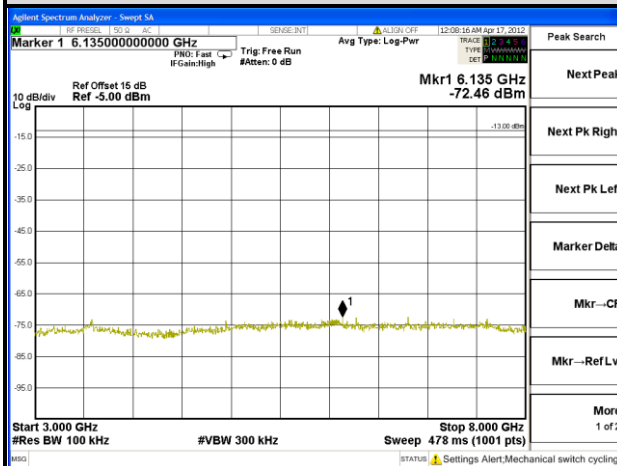



A D T

CHANNEL 23255

FREQUENCY RANGE : 30MHz~1GHz

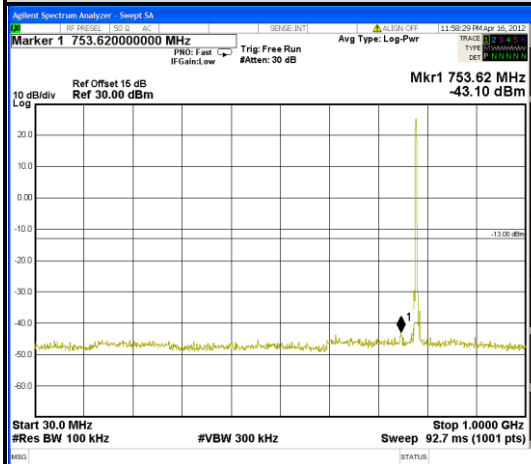

FREQUENCY RANGE : 1GHz~3GHz

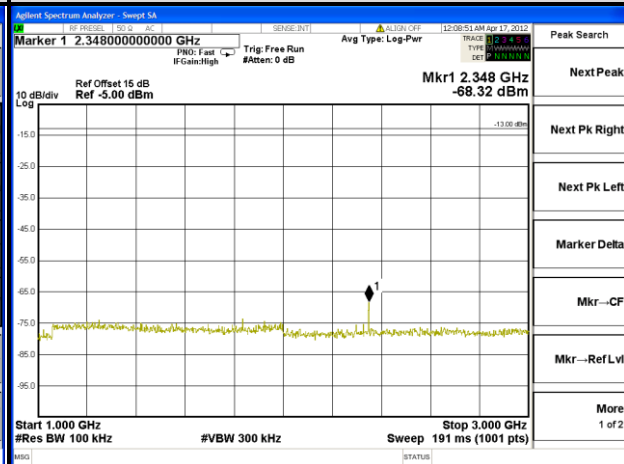

FREQUENCY RANGE : 3GHz~8GHz

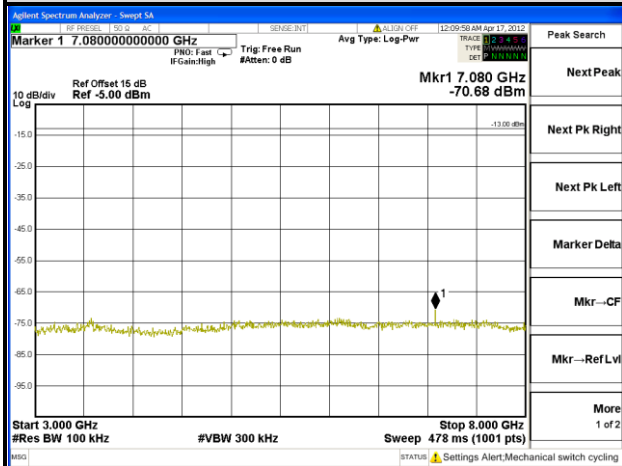



A D T

5MHz / QPSK / 24 RB Offset

CHANNEL 23205

FREQUENCY RANGE : 30MHz~1GHz

FREQUENCY RANGE : 1GHz~3GHz

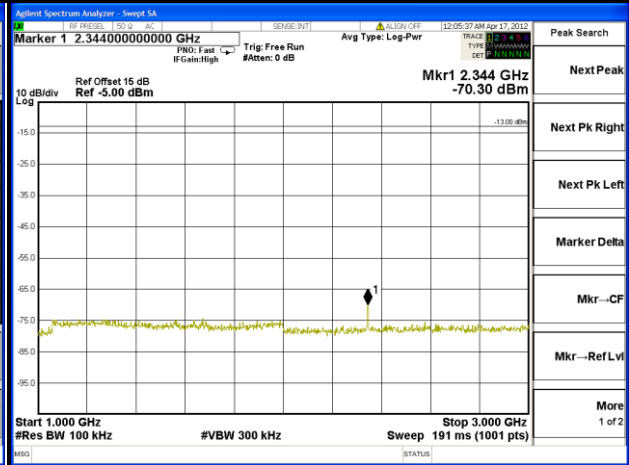
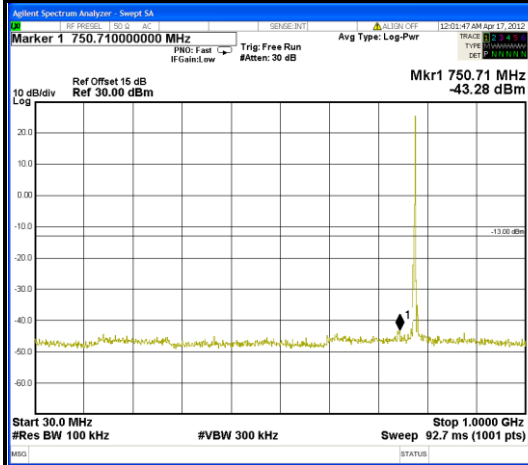

FREQUENCY RANGE : 3GHz~8GHz

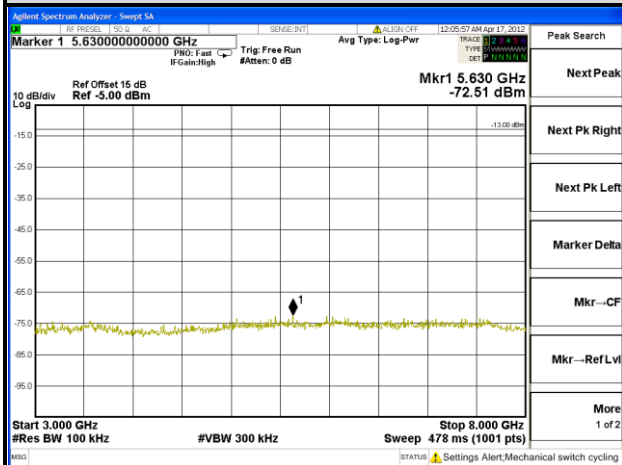



A D T

CHANNEL 23230

FREQUENCY RANGE : 30MHz~1GHz

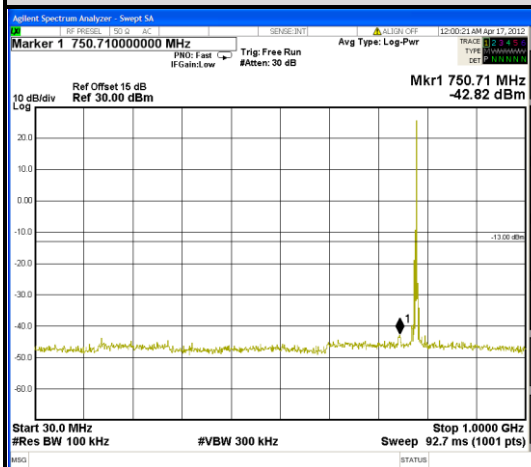

FREQUENCY RANGE : 1GHz~3GHz

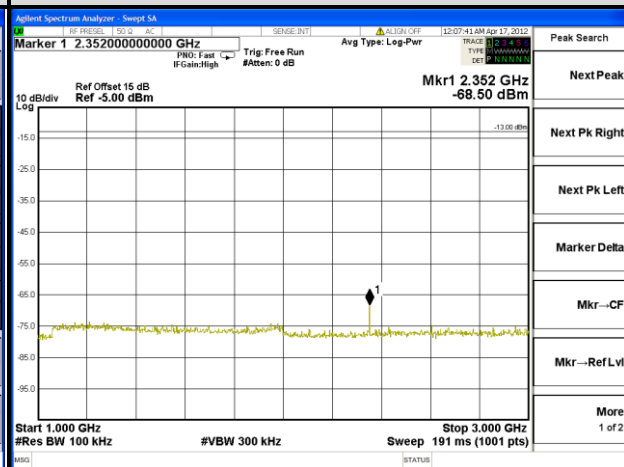

FREQUENCY RANGE : 3GHz~8GHz

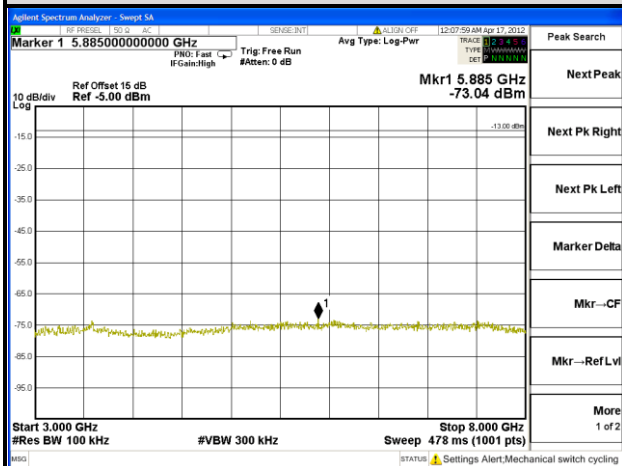



A D T

CHANNEL 23255

FREQUENCY RANGE : 30MHz~1GHz

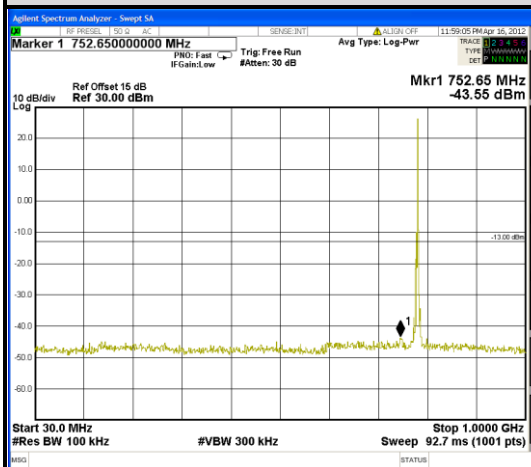

FREQUENCY RANGE : 1GHz~3GHz

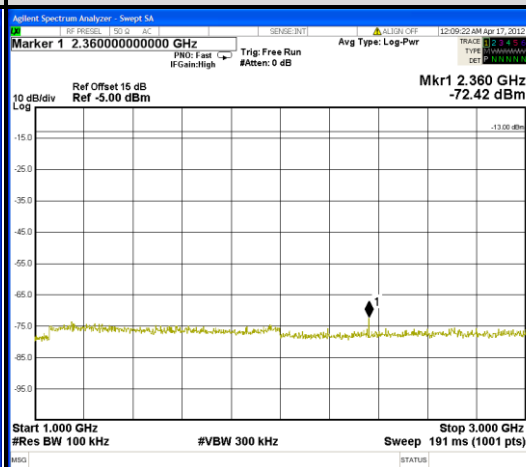

FREQUENCY RANGE : 3GHz~8GHz

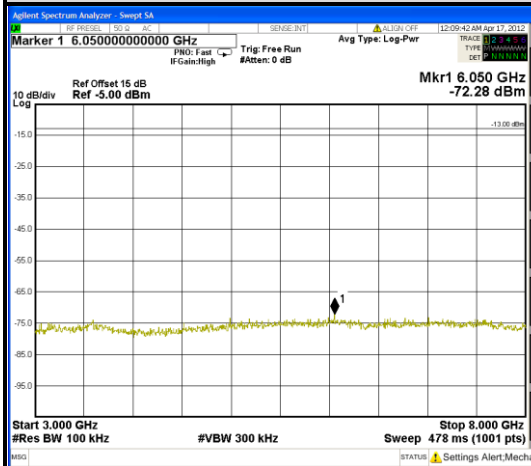



A D T

10MHz / QPSK / 0 RB Offset

CHANNEL 23230

FREQUENCY RANGE : 30MHz~1GHz

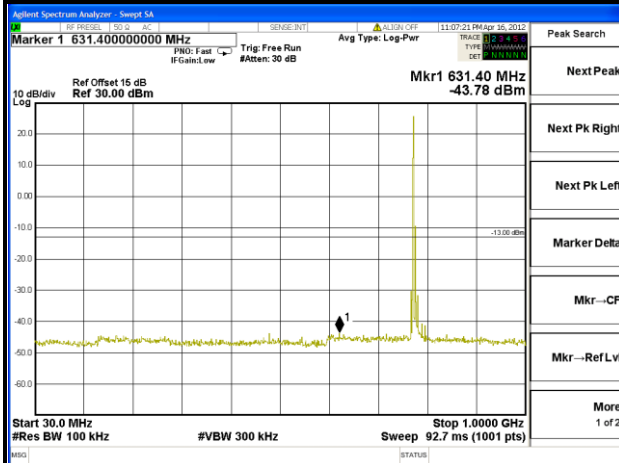

FREQUENCY RANGE : 1GHz~3GHz

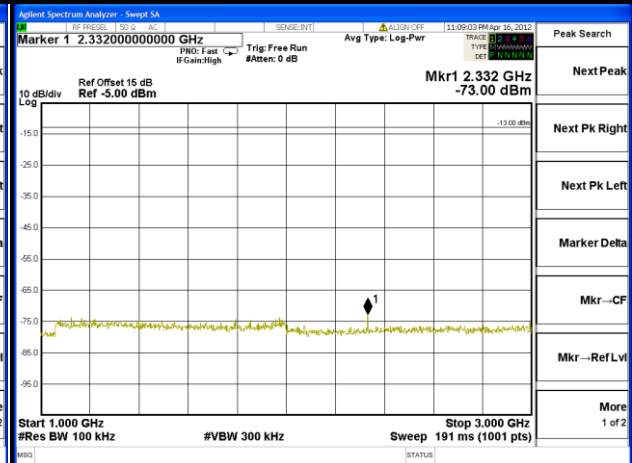

FREQUENCY RANGE : 3GHz~8GHz

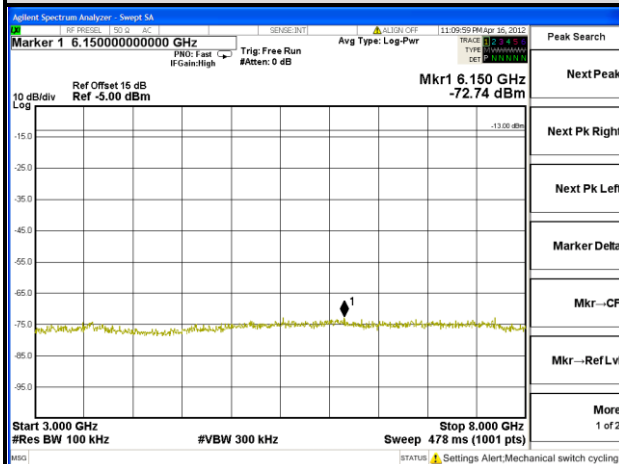



A D T

10MHz / QPSK / 24 RB Offset

CHANNEL 23230

FREQUENCY RANGE : 30MHz~1GHz

FREQUENCY RANGE : 1GHz~3GHz

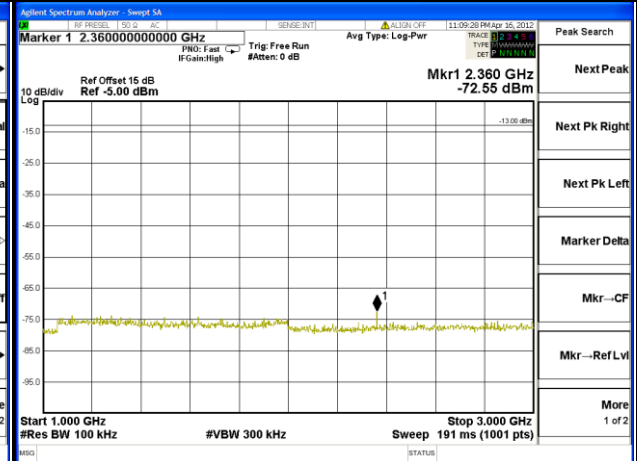

FREQUENCY RANGE : 3GHz~8GHz

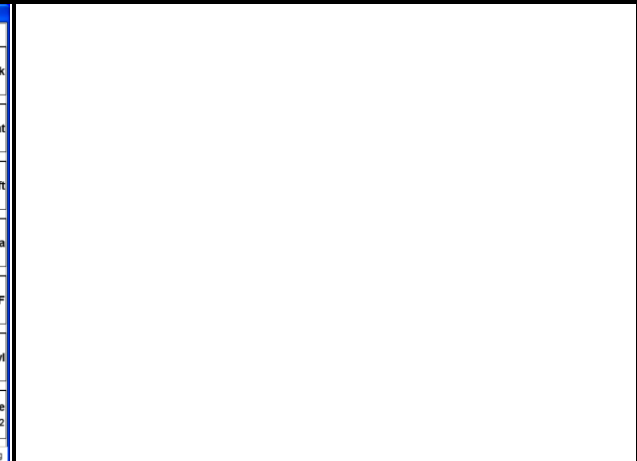
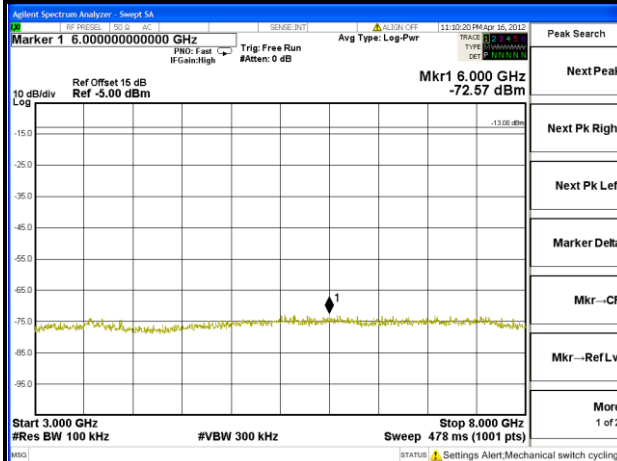



A D T

Channel Bandwidth: 5MHz

CHANNEL	23205	1 RB	CHANNEL	23255	1 RB
----------------	--------------	-------------	----------------	--------------	-------------

Emission at 763~775MHz	Emission at 793~805MHz
-------------------------------	-------------------------------

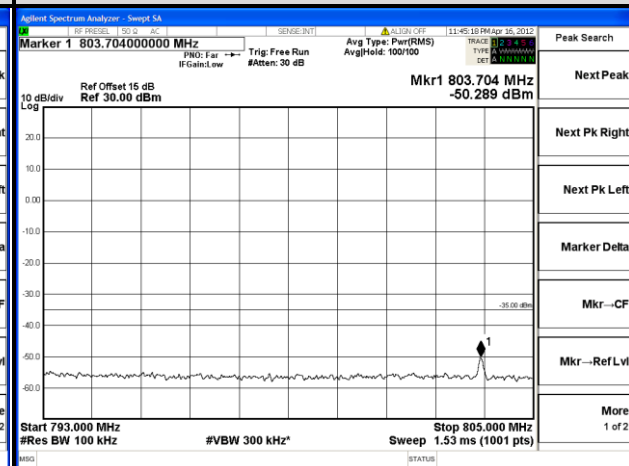
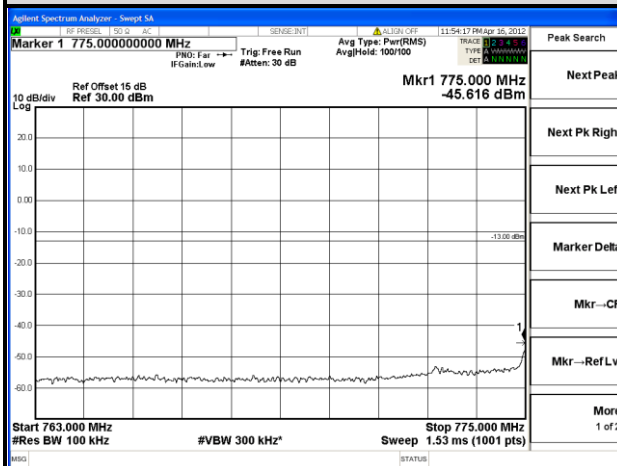

CHANNEL	23205	25 RB	CHANNEL	23255	25 RB
----------------	--------------	--------------	----------------	--------------	--------------

Emission at 763~775MHz	Emission at 793~805MHz
-------------------------------	-------------------------------

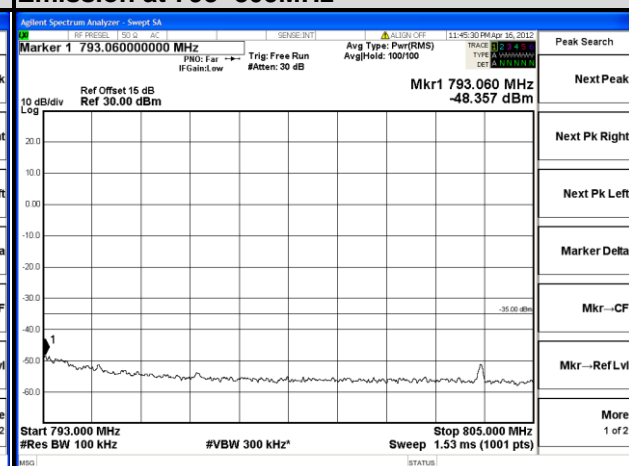



A D T

Channel Bandwidth: 10MHz

CHANNEL	23230	1 RB	CHANNEL	23230	1 RB
----------------	--------------	-------------	----------------	--------------	-------------

Emission at 763~775MHz	Emission at 793~805MHz
-------------------------------	-------------------------------

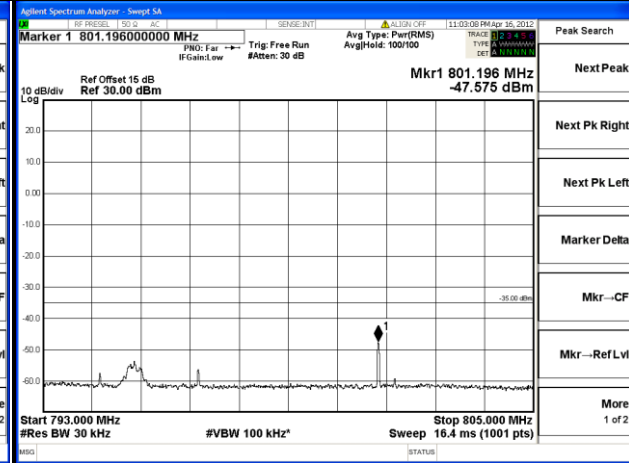

CHANNEL	23230	50 RB	CHANNEL	23230	50 RB
----------------	--------------	--------------	----------------	--------------	--------------

Emission at 763~775MHz	Emission at 793~805MHz
-------------------------------	-------------------------------

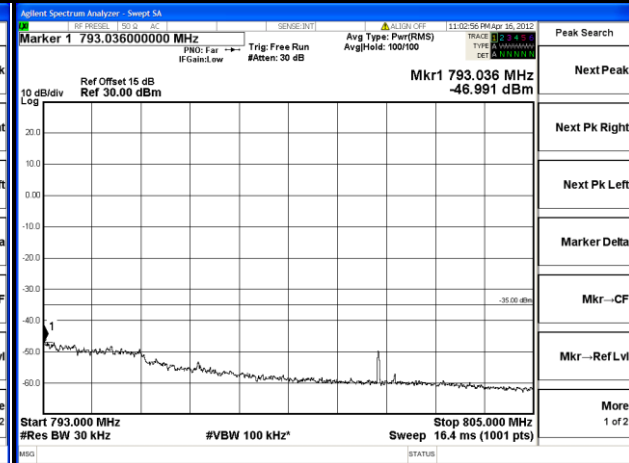
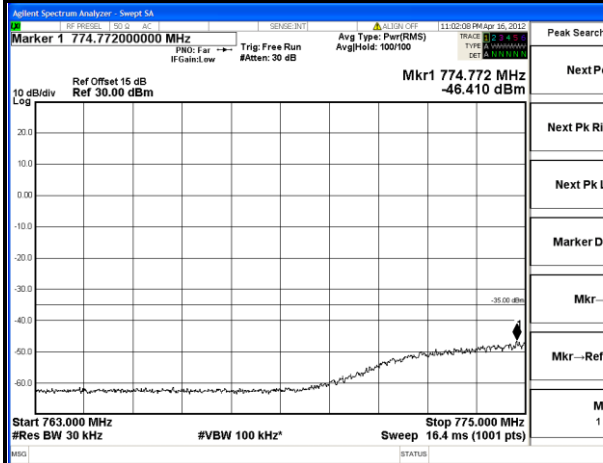

4.7 RADIATED EMISSION MEASUREMENT

4.7.1 LIMITS OF RADIATED EMISSION MEASUREMENT

The power of any emission outside a licensee's frequency block shall be attenuated below the transmitter power (P) by at least $43 + 10 \log_{10}(P)$ dB. The limit of emission equal to -13dBm

4.7.2 TEST PROCEDURES

- a. Substitution method is used for E.I.R.P measurement. In the semi-anechoic chamber, EUT placed on the 0.8m height of Turn Table, rotated the table around 360 degrees to search the maximum radiation power and receiver antenna shall be rotated vertical and horizontal polarization and moved height from 1m to 4m to find the maximum polar radiated power. The "Read Value" is the spectrum reading the maximum power value.
- b. The substitution horn antenna is substituted for EUT at the same position and signals generator export the CW signal to the substitution antenna via a TX cable. Rotated the Turn Table and moved receiving antenna to find the maximum radiation power. Adjust output power level of S.G to get a Value of spectrum reading equal to "Read Value " of step a. Record the power level of S.G
- c. $\text{EIRP} = \text{Output power level of S.G} - \text{TX cable loss} + \text{Antenna gain of substitution horn.}$
- d. E.R.P power can be calculated form E.I.R.P power by subtracting the gain of dipole, $\text{E.R.P power} = \text{E.I.P.R power} - 2.15\text{dBi.}$

NOTE: The resolution bandwidth of spectrum analyzer is 1 MHz and the video bandwidth is 3 MHz.

4.7.3 DEVIATION FROM TEST STANDARD

No deviation

4.7.4 TEST SETUP

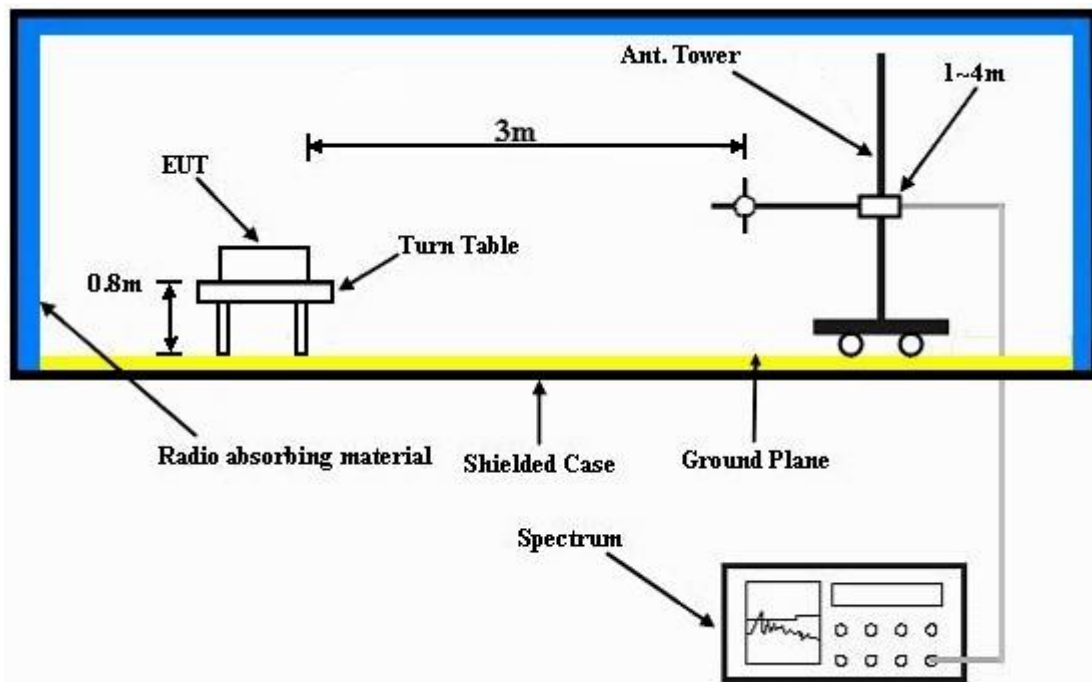

For the actual test configuration, please refer to the attached file (Test Setup Photo).

4.7.5 TEST RESULTS

CHANNEL BANDWIDTH: 5MHz / QPSK



Bureau Veritas Consumer Products Services Ltd., Taoyuan Branch

A D T

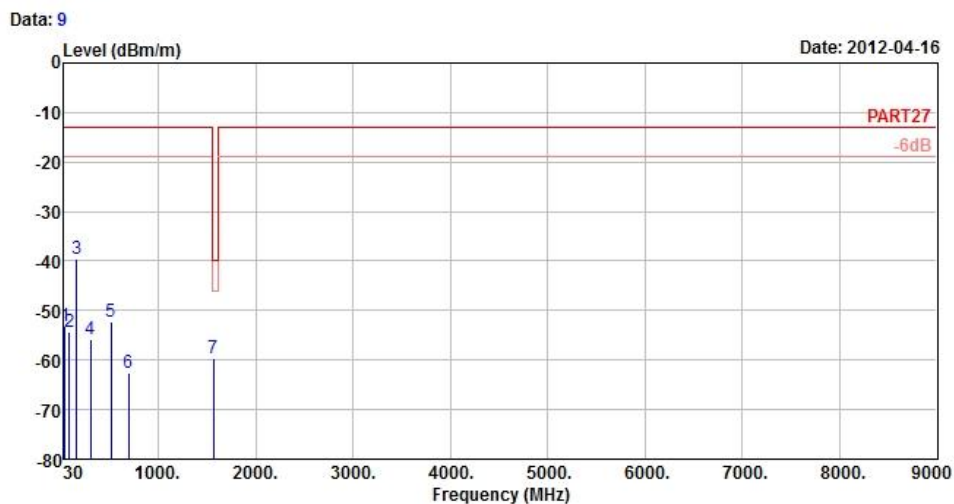

Site : 966 Chamber 5
 Condition : PART27 3m EIRP_RSE_1G~19G_3 HORIZONTAL
 Brand/Model: SKU1
 Remark : LTE Band 13 QPSK(1,24) CH23230_5M
 Tested by : Kay Wu
 Temperature : 25°C
 Humidity : 65%
 Plane : Z

	Freq	Level	Read Level	Limit	Over		
	MHz	dBm/m	dBm	dBm/m	dB	dB/m	Remark
1	38.91	-53.05	-51.31	-13.00	-40.05	-1.74	Peak
2	82.11	-54.27	-43.94	-13.00	-41.27	-10.33	Peak
3	162.30	-39.57	-33.02	-13.00	-26.57	-6.55	Peak
4	300.70	-55.74	-49.37	-13.00	-42.74	-6.37	Peak
5	513.50	-52.17	-49.43	-13.00	-39.17	-2.74	Peak
6	692.70	-62.58	-63.89	-13.00	-49.58	1.31	Peak
7 pp	1564.00	-59.64	-46.37	-40.00	-19.64	-13.27	Peak



A D T



Bureau Veritas Consumer Products Services Ltd., Taoyuan Branch

A D T

Data: 10

Date: 2012-04-16

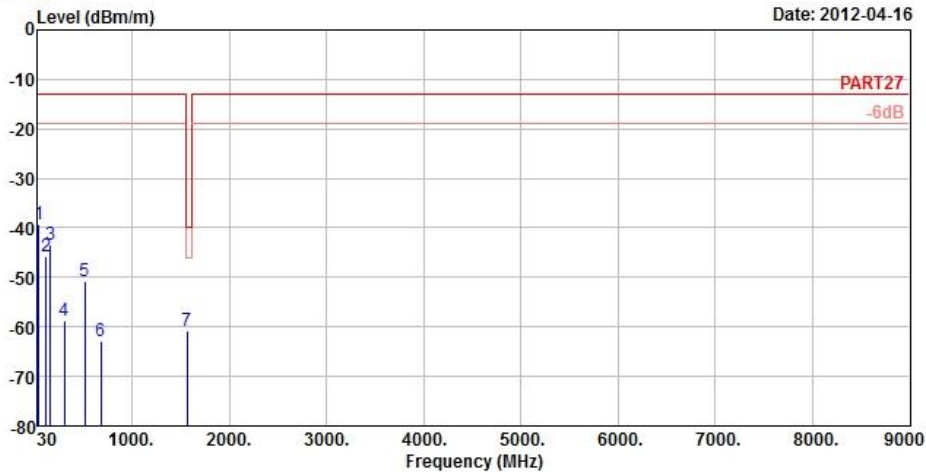

Site : 966 Chamber 5
 Condition : PART27 3m EIRP_RSE_1G~19G_3 VERTICAL
 Brand/Model: SKU1
 Remark : LTE Band 13 QPSK(1,24) CH23230_5M
 Tested by : Kay Wu
 Temperature : 25°C
 Humidity : 65%
 Plane : Z

	Freq	Level	Read	Limit	Over		
	MHz	dBm/m	Level	Line	Limit	Factor	Remark
			dBm	dBm/m	dB	dB/m	
1	41.88	-39.31	-37.92	-13.00	-26.31	-1.39	Peak
2	112.35	-45.83	-35.16	-13.00	-32.83	-10.67	Peak
3	162.84	-43.53	-36.96	-13.00	-30.53	-6.57	Peak
4	304.90	-58.89	-52.55	-13.00	-45.89	-6.34	Peak
5	512.80	-50.78	-48.04	-13.00	-37.78	-2.74	Peak
6	680.10	-62.88	-63.96	-13.00	-49.88	1.08	Peak
7 pp	1564.00	-60.70	-47.43	-40.00	-20.70	-13.27	Peak



A D T



Bureau Veritas Consumer Products Services Ltd., Taoyuan Branch

A D T

Data: 9

Date: 2012-04-16

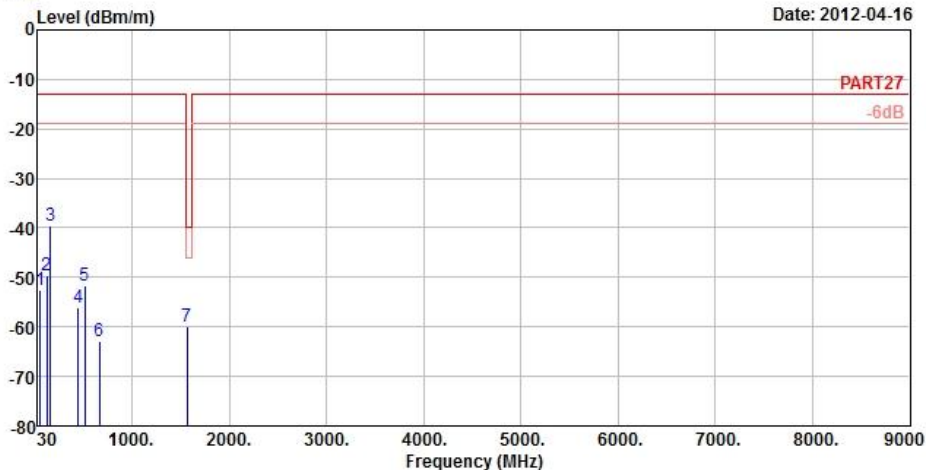

Site : 966 Chamber 5
 Condition : PART27 3m EIRP_RSE_1G~19G_3 HORIZONTAL
 Brand/Model: SKU1
 Remark : LTE Band 13 QPSK(25,0) CH23230_5M
 Tested by : Kay Wu
 Temperature : 25°C
 Humidity : 65%
 Plane : Z

	Freq	Level	Read	Limit	Over		
	MHz	dBm/m	Level	Line	Limit	Factor	Remark
			dBm	dBm/m	dB	dB/m	
1	57.54	-52.61	-46.96	-13.00	-39.61	-5.65	Peak
2	124.23	-49.66	-39.85	-13.00	-36.66	-9.81	Peak
3	162.84	-39.69	-33.12	-13.00	-26.69	-6.57	Peak
4	447.70	-55.97	-51.56	-13.00	-42.97	-4.41	Peak
5	515.60	-51.78	-49.12	-13.00	-38.78	-2.66	Peak
6	664.70	-62.84	-63.64	-13.00	-49.84	0.80	Peak
7 pp	1564.00	-59.99	-46.72	-40.00	-19.99	-13.27	Peak



A D T



Bureau Veritas Consumer Products Services Ltd., Taoyuan Branch

A D T

Data: 10

Date: 2012-04-16

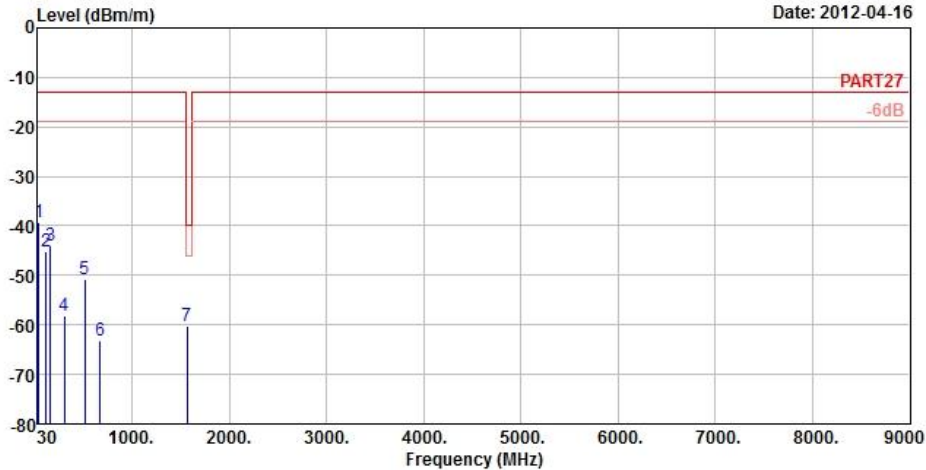

Site : 966 Chamber 5
 Condition : PART27 3m EIRP_RSE_1G~19G_3 VERTICAL
 Brand/Model: SKU1
 Remark : LTE Band 13 QPSK(25,0) CH23230_5M
 Tested by : Kay Wu
 Temperature : 25°C
 Humidity : 65%
 Plane : Z

	Freq	Level	Read	Limit	Over		
	MHz	dBm/m	Level	Line	Limit	Factor	Remark
			dBm	dBm/m	dB	dB/m	
1	41.88	-39.12	-37.73	-13.00	-26.12	-1.39	Peak
2	112.08	-45.18	-34.51	-13.00	-32.18	-10.67	Peak
3	162.57	-43.97	-37.40	-13.00	-30.97	-6.57	Peak
4	302.10	-58.15	-51.79	-13.00	-45.15	-6.36	Peak
5	514.90	-50.90	-48.21	-13.00	-37.90	-2.69	Peak
6	672.40	-63.09	-64.03	-13.00	-50.09	0.94	Peak
7 pp	1564.00	-60.29	-47.02	-40.00	-20.29	-13.27	Peak

CHANNEL BANDWIDTH: 5MHz / 16QAM



Bureau Veritas Consumer Products Services Ltd., Taoyuan Branch

A D T

Data: 9

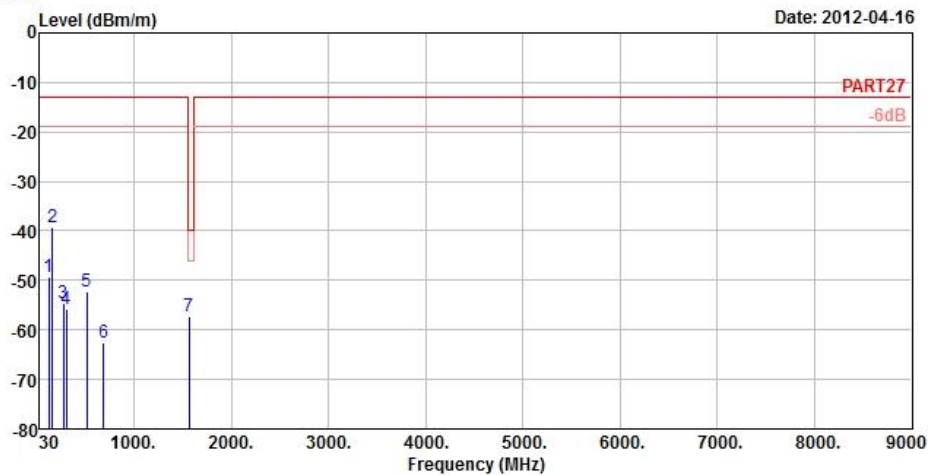

Site : 966 Chamber 5
 Condition : PART27 3m EIRP_RSE_1G~19G_3 HORIZONTAL
 Brand/Model : SKU1
 Remark : LTE Band 13 16QAM(1,24) CH23230_5M
 Tested by : Kay Wu
 Temperature : 25°C
 Humidity : 65%
 Plane : Z

	Freq	Level	Read	Limit	Over		
	MHz	dBm/m	Level	Line	Limit	Factor	Remark
			dBm	dBm/m	dB	dB/m	
1	124.50	-49.29	-39.48	-13.00	-36.29	-9.81	Peak
2	162.84	-39.31	-32.74	-13.00	-26.31	-6.57	Peak
3	273.27	-54.60	-48.59	-13.00	-41.60	-6.01	Peak
4	300.00	-55.85	-49.47	-13.00	-42.85	-6.38	Peak
5	516.30	-52.26	-49.60	-13.00	-39.26	-2.66	Peak
6	682.90	-62.68	-63.82	-13.00	-49.68	1.14	Peak
7 pp	1564.00	-57.38	-44.11	-40.00	-17.38	-13.27	Peak



A D T



Bureau Veritas Consumer Products Services Ltd., Taoyuan Branch

A D T

Data: 10

Date: 2012-04-16

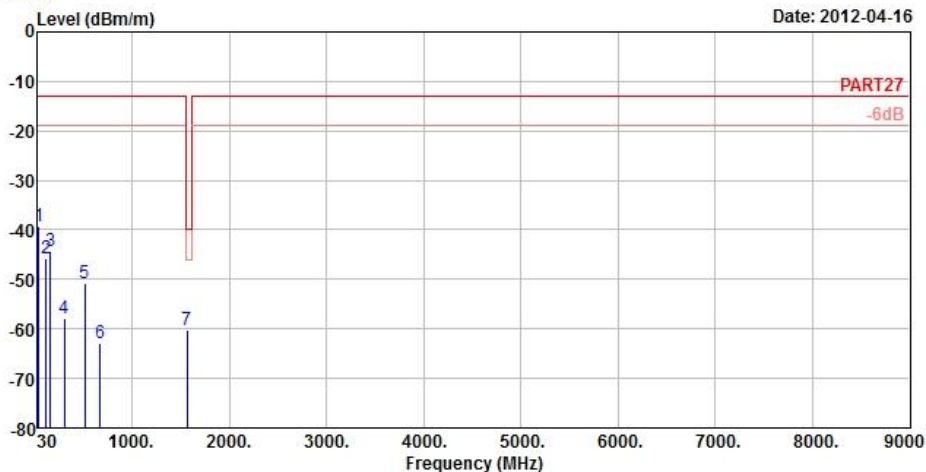

Site : 966 Chamber 5
 Condition : PART27 3m EIRP_RSE_1G~19G_3 VERTICAL
 Brand/Model: SKU1
 Remark : LTE Band 13 16QAM(1,24) CH23230_5M
 Tested by : Kay Wu
 Temperature : 25°C
 Humidity : 65%
 Plane : Z

	Freq	Level	Read	Limit	Over		
	MHz	dBm/m	Level	Line	Limit	Factor	Remark
			dBm	dBm/m	dB	dB/m	
1	41.61	-39.23	-37.84	-13.00	-26.23	-1.39	Peak
2	112.35	-45.84	-35.17	-13.00	-32.84	-10.67	Peak
3	162.57	-44.21	-37.64	-13.00	-31.21	-6.57	Peak
4	302.80	-57.90	-51.54	-13.00	-44.90	-6.36	Peak
5	514.90	-50.81	-48.12	-13.00	-37.81	-2.69	Peak
6	671.00	-63.02	-63.95	-13.00	-50.02	0.93	Peak
7 pp	1564.00	-60.27	-47.00	-40.00	-20.27	-13.27	Peak



A D T



Bureau Veritas Consumer Products Services Ltd., Taoyuan Branch

A D T

Data: 9

Date: 2012-04-16

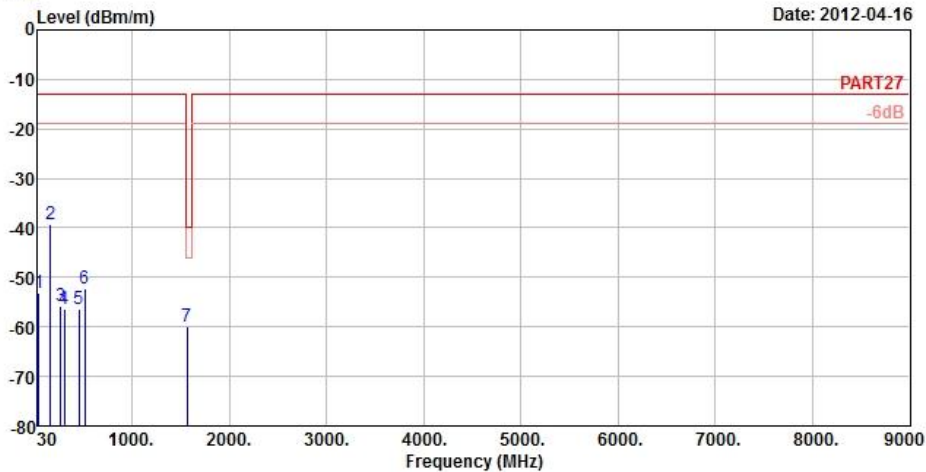

Site : 966 Chamber 5
 Condition : PART27 3m EIRP_RSE_1G~19G_3 HORIZONTAL
 Brand/Model: SKU1
 Remark : LTE Band 13 16QAM(25,0) CH23230_5M
 Tested by : Kay Wu
 Temperature : 25°C
 Humidity : 65%
 Plane : Z

	Freq	Level	Read	Limit	Over		
	MHz	dBm/m	Level	Line	Limit	Factor	Remark
			dBm	dBm/m	dB	dB/m	
1	38.37	-53.17	-51.43	-13.00	-40.17	-1.74	Peak
2	162.30	-39.37	-32.82	-13.00	-26.37	-6.55	Peak
3	268.41	-55.78	-49.84	-13.00	-42.78	-5.94	Peak
4	300.70	-56.36	-49.99	-13.00	-43.36	-6.37	Peak
5	456.10	-56.39	-52.17	-13.00	-43.39	-4.22	Peak
6	514.90	-52.20	-49.51	-13.00	-39.20	-2.69	Peak
7 pp	1564.00	-60.01	-46.74	-40.00	-20.01	-13.27	Peak



A D T



Bureau Veritas Consumer Products Services Ltd., Taoyuan Branch

A D T

Data: 10

Date: 2012-04-16

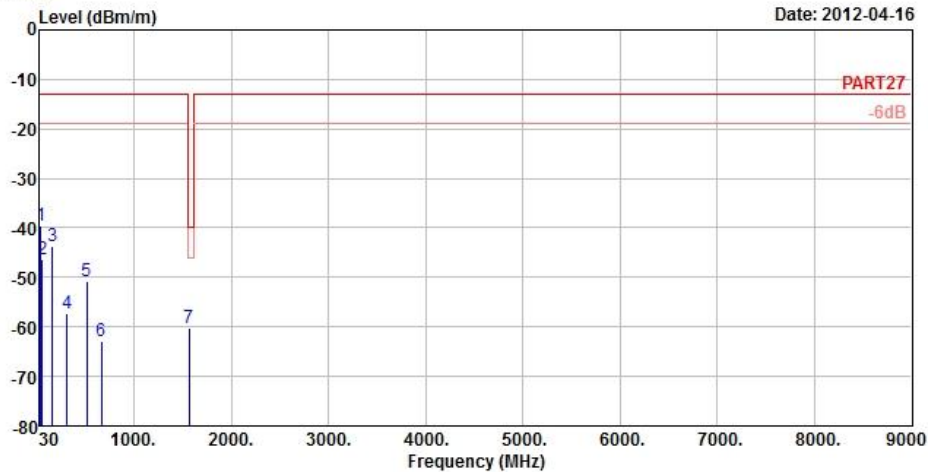

Site : 966 Chamber 5
 Condition : PART27 3m EIRP_RSE_1G~19G_3 VERTICAL
 Brand/Model: SKU1
 Remark : LTE Band 13 16QAM(25,0) CH23230_5M
 Tested by : Kay Wu
 Temperature : 25°C
 Humidity : 65%
 Plane : Z

	Freq	Level	Read	Limit	Over		
	MHz	dBm/m	Level	Line	Limit	Factor	Remark
			dBm	dBm/m	dB	dB/m	
1	41.34	-39.43	-38.04	-13.00	-26.43	-1.39	Peak
2	56.19	-46.42	-40.92	-13.00	-33.42	-5.50	Peak
3	162.84	-43.83	-37.26	-13.00	-30.83	-6.57	Peak
4	309.10	-57.27	-50.96	-13.00	-44.27	-6.31	Peak
5	514.90	-50.65	-47.96	-13.00	-37.65	-2.69	Peak
6	662.60	-62.85	-63.62	-13.00	-49.85	0.77	Peak
7 pp	1564.00	-60.20	-46.93	-40.00	-20.20	-13.27	Peak

CHANNEL BANDWIDTH: 10MHz / QPSK



Bureau Veritas Consumer Products Services Ltd., Taoyuan Branch

A D T

Data: 9

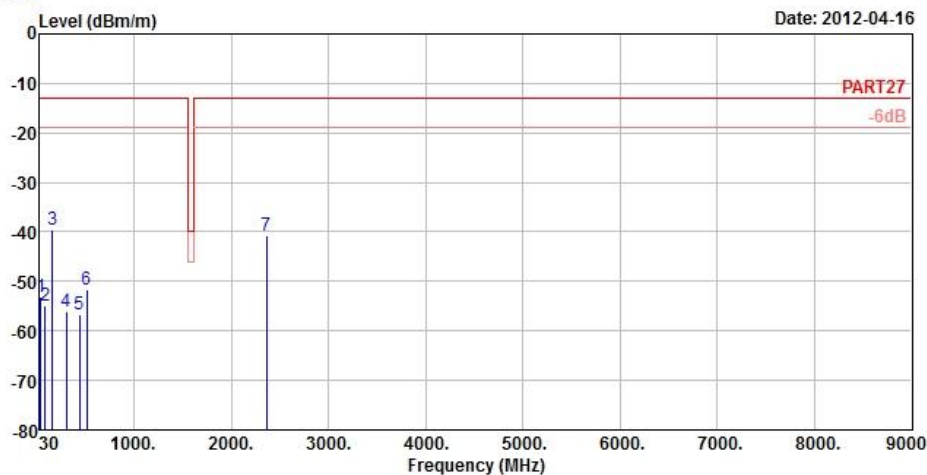

Site : 966 Chamber 5
 Condition : PART27 3m EIRP_RSE_1G~19G_3 HORIZONTAL
 Brand/Model: SKU1
 Remark : LTE Band 13 QPSK(1,49) CH23230_10M
 Tested by : Kay Wu
 Temperature : 25°C
 Humidity : 65%
 Plane : Z

	Freq	Level	Read Level	Limit Line	Over Limit	Factor	Remark
	MHz	dBm/m	dBm	dBm/m	dB	dB/m	
1	38.10	-53.15	-51.20	-13.00	-40.15	-1.95	Peak
2	82.65	-54.86	-44.53	-13.00	-41.86	-10.33	Peak
3 pp	162.57	-39.48	-32.91	-13.00	-26.48	-6.57	Peak
4	301.40	-56.06	-49.69	-13.00	-43.06	-6.37	Peak
5	440.00	-56.63	-52.02	-13.00	-43.63	-4.61	Peak
6	512.80	-51.74	-49.00	-13.00	-38.74	-2.74	Peak
7	2359.00	-40.65	-31.51	-13.00	-27.65	-9.14	Peak



A D T



Bureau Veritas Consumer Products Services Ltd., Taoyuan Branch

A D T

Data: 10

Date: 2012-04-16

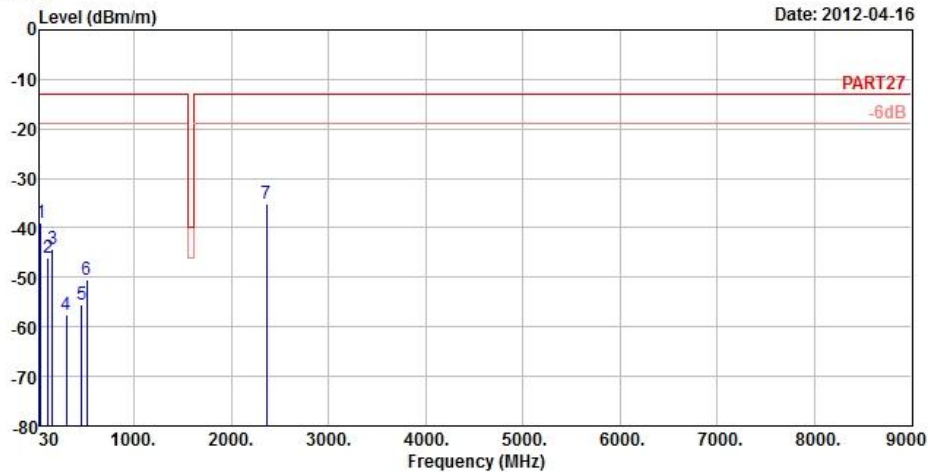

Site : 966 Chamber 5
 Condition : PART27 3m EIRP_RSE_1G~19G_3 VERTICAL
 Brand/Model: SKU1
 Remark : LTE Band 13 QPSK(1,49) CH23230_10M
 Tested by : Kay Wu
 Temperature : 25°C
 Humidity : 65%
 Plane : Z

	Freq	Level	Read	Limit	Over		
	MHz	dBm/m	Level	Line	Limit	Factor	Remark
			dBm	dBm/m	dB	dB/m	
1	41.07	-38.94	-37.48	-13.00	-25.94	-1.46	Peak
2	113.43	-46.18	-35.49	-13.00	-33.18	-10.69	Peak
3	162.57	-44.23	-37.66	-13.00	-31.23	-6.57	Peak
4	300.00	-57.68	-51.30	-13.00	-44.68	-6.38	Peak
5	461.00	-55.56	-51.46	-13.00	-42.56	-4.10	Peak
6	514.20	-50.53	-47.81	-13.00	-37.53	-2.72	Peak
7 pp	2359.00	-35.04	-25.90	-13.00	-22.04	-9.14	Peak



A D T



Bureau Veritas Consumer Products Services Ltd., Taoyuan Branch

A D T

Data: 9

Date: 2012-04-16

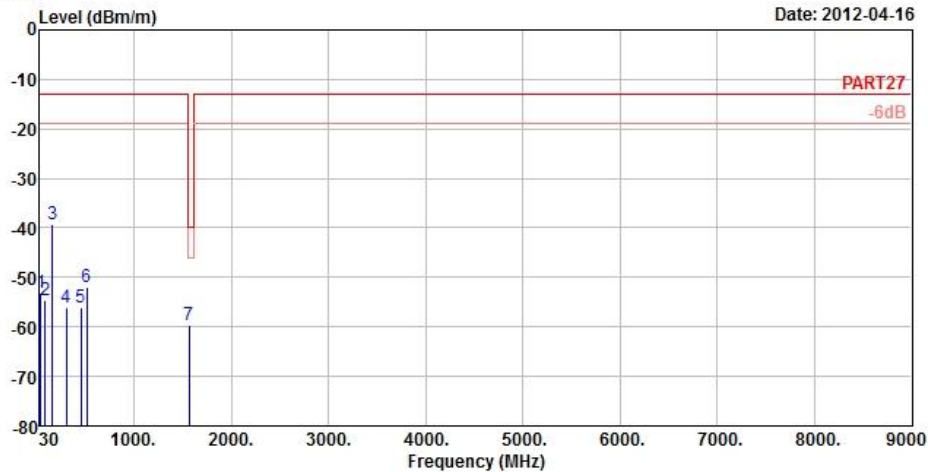

Site : 966 Chamber 5
 Condition : PART27 3m EIRP_RSE_1G~19G_3 HORIZONTAL
 Brand/Model: SKU1
 Remark : LTE Band 13 QPSK(50,0) CH23230_10M
 Tested by : Kay Wu
 Temperature : 25°C
 Humidity : 65%
 Plane : Z

	Freq	Level	Read Level	Limit Line	Over Limit	Factor	Remark
	MHz	dBm/m	dBm	dBm/m	dB	dB/m	
1	38.64	-53.18	-51.44	-13.00	-40.18	-1.74	Peak
2	81.57	-54.72	-44.42	-13.00	-41.72	-10.30	Peak
3	162.30	-39.27	-32.72	-13.00	-26.27	-6.55	Peak
4	300.00	-55.99	-49.61	-13.00	-42.99	-6.38	Peak
5	456.10	-56.20	-51.98	-13.00	-43.20	-4.22	Peak
6	513.50	-51.98	-49.24	-13.00	-38.98	-2.74	Peak
7 pp	1564.00	-59.59	-46.32	-40.00	-19.59	-13.27	Peak



A D T



Bureau Veritas Consumer Products Services Ltd., Taoyuan Branch

A D T

Data: 10

Date: 2012-04-16

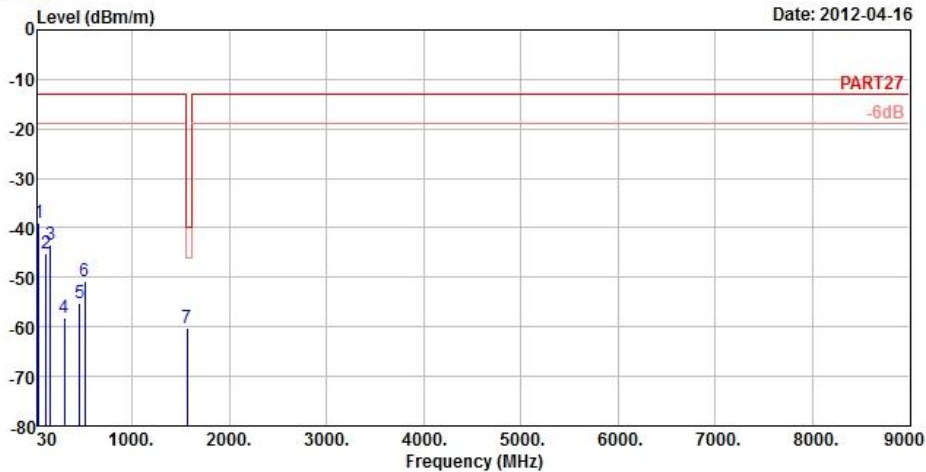

Site : 966 Chamber 5
 Condition : PART27 3m EIRP_RSE_1G~19G_3 VERTICAL
 Brand/Model: SKU1
 Remark : LTE Band 13 QPSK(50,0) CH23230_10M
 Tested by : Kay Wu
 Temperature : 25°C
 Humidity : 65%
 Plane : Z

	Freq	Level	Read	Limit	Over		
	MHz	dBm/m	Level	Line	Limit	Factor	Remark
			dBm	dBm/m	dB	dB/m	
1	41.34	-39.10	-37.71	-13.00	-26.10	-1.39	Peak
2	113.16	-45.25	-34.56	-13.00	-32.25	-10.69	Peak
3	163.11	-43.40	-36.83	-13.00	-30.40	-6.57	Peak
4	305.60	-58.15	-51.81	-13.00	-45.15	-6.34	Peak
5	460.30	-55.34	-51.24	-13.00	-42.34	-4.10	Peak
6	514.90	-50.64	-47.95	-13.00	-37.64	-2.69	Peak
7 pp	1564.00	-60.20	-46.93	-40.00	-20.20	-13.27	Peak

CHANNEL BANDWIDTH: 10MHz / 16QAM



Bureau Veritas Consumer Products Services Ltd., Taoyuan Branch

A D T

Data: 9

Date: 2012-04-16

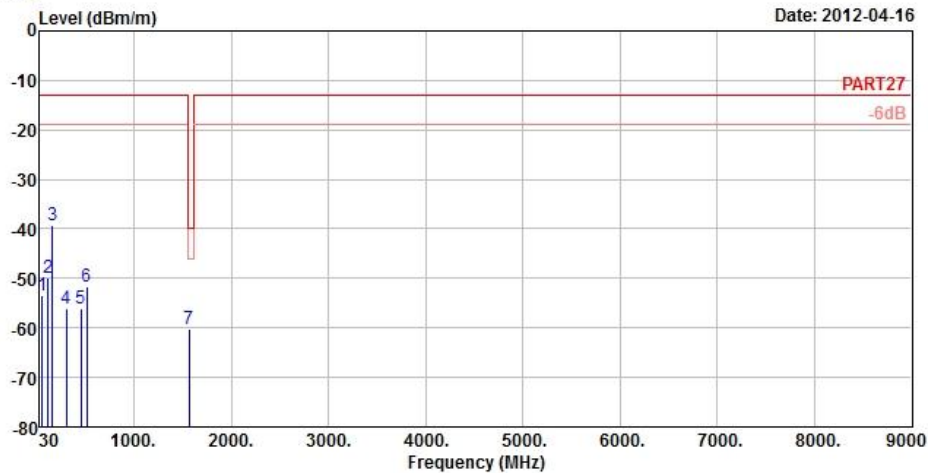

Site : 966 Chamber 5
 Condition : PART27 3m EIRP_RSE_1G~19G_3 HORIZONTAL
 Brand/Model : SKU1
 Remark : LTE Band 13 16QAM(1,0) CH23230_10M
 Tested by : Kay Wu
 Temperature : 25°C
 Humidity : 65%
 Plane : Z

	Freq	Level	Read	Limit	Over		
	MHz	dBm/m	Level	Line	Limit	Factor	Remark
			dBm	dBm/m	dB	dB/m	
1	55.92	-53.37	-47.87	-13.00	-40.37	-5.50	Peak
2	113.43	-49.96	-39.27	-13.00	-36.96	-10.69	Peak
3	162.57	-39.25	-32.68	-13.00	-26.25	-6.57	Peak
4	300.00	-56.06	-49.68	-13.00	-43.06	-6.38	Peak
5	456.10	-56.12	-51.90	-13.00	-43.12	-4.22	Peak
6	512.10	-51.61	-48.84	-13.00	-38.61	-2.77	Peak
7 pp	1564.00	-60.29	-47.02	-40.00	-20.29	-13.27	Peak



A D T



Bureau Veritas Consumer Products Services Ltd., Taoyuan Branch

A D T

Data: 10

Date: 2012-04-16

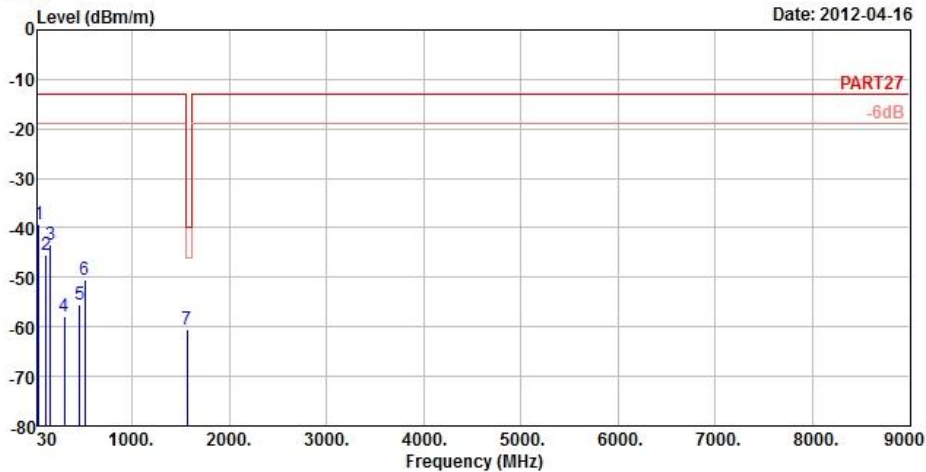

Site : 966 Chamber 5
 Condition : PART27 3m EIRP_RSE_1G~19G_3 VERTICAL
 Brand/Model: SKU1
 Remark : LTE Band 13 16QAM(1,0) CH23230_10M
 Tested by : Kay Wu
 Temperature : 25°C
 Humidity : 65%
 Plane : Z

	Freq	Level	Read	Limit	Over		
	MHz	dBm/m	Level	Line	Limit	Factor	Remark
			dBm	dBm/m	dB	dB/m	
1	41.07	-39.15	-37.69	-13.00	-26.15	-1.46	Peak
2	112.35	-45.50	-34.83	-13.00	-32.50	-10.67	Peak
3	163.11	-43.53	-36.96	-13.00	-30.53	-6.57	Peak
4	302.80	-57.77	-51.41	-13.00	-44.77	-6.36	Peak
5	462.40	-55.52	-51.47	-13.00	-42.52	-4.05	Peak
6	514.20	-50.44	-47.72	-13.00	-37.44	-2.72	Peak
7 pp	1564.00	-60.50	-47.23	-40.00	-20.50	-13.27	Peak



A D T



Bureau Veritas Consumer Products Services Ltd., Taoyuan Branch

A D T

Data: 9

Date: 2012-04-16

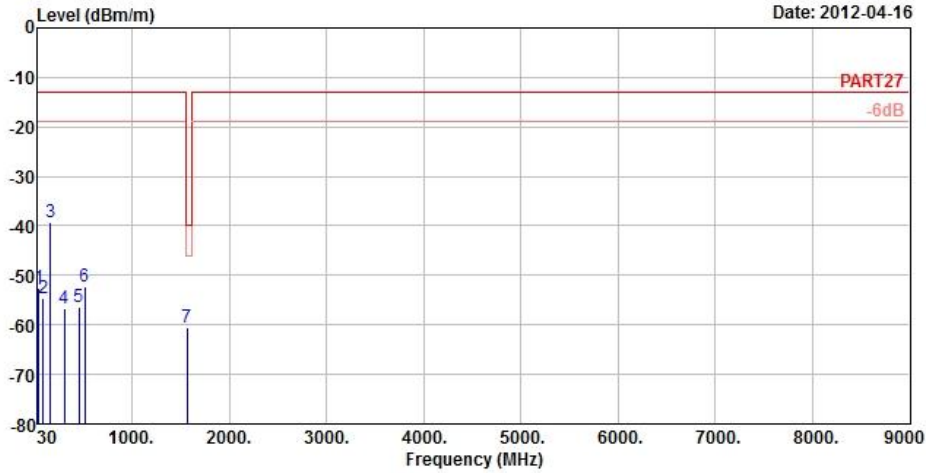

Site : 966 Chamber 5
 Condition : PART27 3m EIRP_RSE_1G~19G_3 HORIZONTAL
 Brand/Model: SKU1
 Remark : LTE Band 13 16QAM(50,0) CH23230_10M
 Tested by : Kay Wu
 Temperature : 25°C
 Humidity : 65%
 Plane : Z

	Freq	Level	Read	Limit	Over		
	MHz	dBm/m	Level	Line	Limit	Factor	Remark
			dBm	dBm/m	dB	dB/m	
1	38.10	-52.44	-50.49	-13.00	-39.44	-1.95	Peak
2	82.11	-54.75	-44.42	-13.00	-41.75	-10.33	Peak
3	162.57	-39.27	-32.70	-13.00	-26.27	-6.57	Peak
4	300.00	-56.71	-50.33	-13.00	-43.71	-6.38	Peak
5	456.10	-56.27	-52.05	-13.00	-43.27	-4.22	Peak
6	514.90	-52.11	-49.42	-13.00	-39.11	-2.69	Peak
7 pp	1564.00	-60.50	-47.23	-40.00	-20.50	-13.27	Peak



A D T



Bureau Veritas Consumer Products Services Ltd., Taoyuan Branch

A D T

Data: 10

Date: 2012-04-16

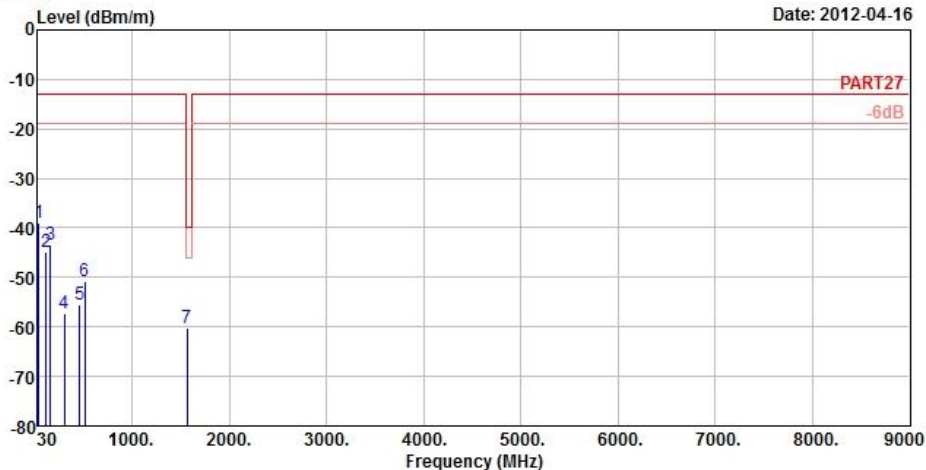

Site : 966 Chamber 5
 Condition : PART27 3m EIRP_RSE_1G~19G_3 VERTICAL
 Brand/Model: SKU1
 Remark : LTE Band 13 16QAM(50,0) CH23230_10M
 Tested by : Kay Wu
 Temperature : 25°C
 Humidity : 65%
 Plane : Z

	Freq	Level	Read	Limit	Over		
	MHz	dBm/m	Level	Line	Limit	Factor	Remark
			dBm	dBm/m	dB	dB/m	
1	41.61	-39.03	-37.64	-13.00	-26.03	-1.39	Peak
2	112.35	-44.79	-34.12	-13.00	-31.79	-10.67	Peak
3	162.84	-43.28	-36.71	-13.00	-30.28	-6.57	Peak
4	301.40	-57.38	-51.01	-13.00	-44.38	-6.37	Peak
5	460.30	-55.50	-51.40	-13.00	-42.50	-4.10	Peak
6	514.20	-50.63	-47.91	-13.00	-37.63	-2.72	Peak
7 pp	1564.00	-60.27	-47.00	-40.00	-20.27	-13.27	Peak



5 INFORMATION ON THE TESTING LABORATORIES

We, Bureau Veritas Consumer Products Services (H.K.) Ltd., Taoyuan Branch, were founded in 1988 to provide our best service in EMC, Radio, Telecom and Safety consultation. Our laboratories are accredited and approved according to ISO/IEC 17025.

If you have any comments, please feel free to contact us at the following:

Linko EMC/RF Lab:

Tel: 886-2-26052180

Fax: 886-2-26051924

Hsin Chu EMC/RF Lab:

Tel: 886-3-5935343

Fax: 886-3-5935342

Hwa Ya EMC/RF/Safety/Telecom Lab:

Tel: 886-3-3183232

Fax: 886-3-3270892

Email: service.adt@tw.bureauveritas.com

Web Site: www.adt.com.tw

The address and road map of all our labs can be found in our web site also.

6 APPENDIX A – MODIFICATIONS RECORDERS FOR ENGINEERING CHANGES TO THE EUT BY THE LAB

No modifications were made to the EUT by the lab during the test.

---END---