

APPENDIX A: SAR TEST DATA

PCTEST ENGINEERING LABORATORY, INC.

DUT: CF -18; Type: Notebook PC with WLANa+b+g & Bluetooth & HSDPA; SN: 5KKS50328

Communication System: GSM 850 GPRS; 2 Tx slots; Frequency: 836.6 MHz; Duty Cycle: 1:4.15

Medium: 835 Muscle ($\sigma = 0.99$ mho/m, $\epsilon_r = 54.73$, $\rho = 1000$ kg/m³)

Phantom section: Flat Section; Space: 0.0cm from DUT to Flat Phantom

Test Date: 01-09-2006; Ambient Temp: 23.5°C; Tissue Temp: 21.6°C

Probe: EX3DV4 - SN3561; ConvF(7.9, 7.9, 7.9); Calibrated: 8/24/2005

Sensor-Surface: 3mm (Mechanical Surface Detection)

Electronics: DAE4 Sn649; Calibrated: 9/13/2005

Phantom: SAM Main; Type: SAM 4.0; Serial: TP:1197

Measurement SW: DASY4, V4.6 Build 19; Postprocessing SW: SEMCAD, V1.8 Build 159

Bystander position, LCD Open, Ch.190

Area Scan (5x17x1): Measurement grid: dx=15mm, dy=15mm

Zoom Scan (5x5x7)/Cube 0: Measurement grid: dx=8mm, dy=8mm, dz=5mm

Reference Value = 10.2 V/m

Peak SAR (extrapolated) = 0.791 W/kg

SAR(1 g) = 0.515 mW/g; SAR(10 g) = 0.322 mW/g

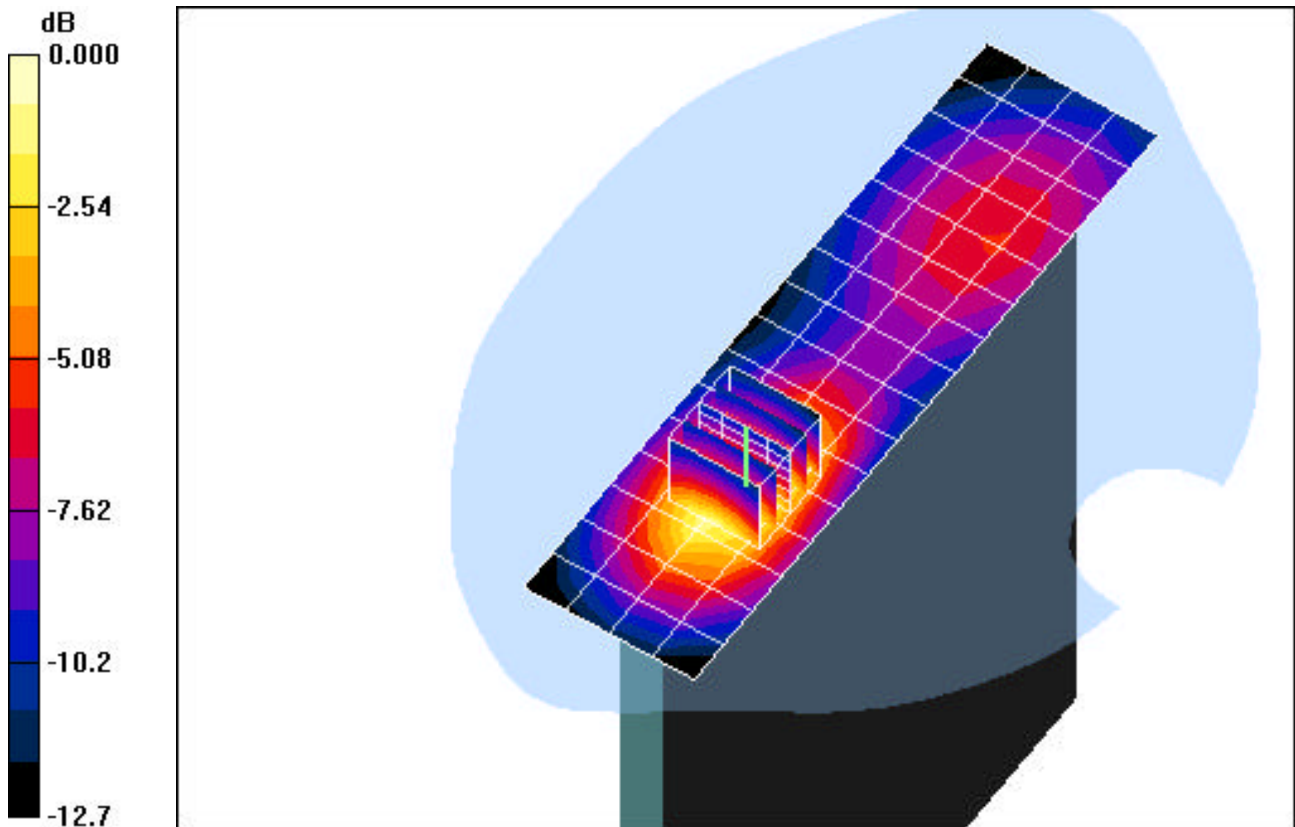

0 dB = 0.612mW/g

PCTEST ENGINEERING LABORATORY, INC.

DUT: CF-18; Type: Notebook PC with WLANa+b+g & Bluetooth & HSDPA; SN: 5KKS50328

Communication System: GSM 850 GPRS; 2 Tx slots; Frequency: 836.6 MHz; Duty Cycle: 1:4.15

Medium: 835 Muscle ($\sigma = 0.99$ mho/m, $\epsilon_r = 54.73$, $\rho = 1000$ kg/m³)

Phantom section: Flat Section; Space: 0.0cm from DUT to Flat Phantom

Test Date: 01-09-2006; Ambient Temp: 23.5°C; Tissue Temp: 21.6°C

Probe: EX3DV4 - SN3561; ConvF(7.9, 7.9, 7.9); Calibrated: 8/24/2005

Sensor-Surface: 3mm (Mechanical Surface Detection)

Electronics: DAE4 Sn649; Calibrated: 9/13/2005

Phantom: SAM Main; Type: SAM 4.0; Serial: TP:1197

Measurement SW: DASY4, V4.6 Build 19; Postprocessing SW: SEMCAD, V1.8 Build 159

Tablet Position, LCD Flip, Ch.190, w/ WLAN 802.11b, Ch.06, 5.5mbps

Area Scan (7x17x1): Measurement grid: dx=15mm, dy=15mm

Zoom Scan (5x5x7)/Cube 0: Measurement grid: dx=8mm, dy=8mm, dz=5mm

Reference Value = 10.3 V/m

Peak SAR (extrapolated) = 0.952 W/kg

SAR(1 g) = 0.611 mW/g; SAR(10 g) = 0.385 mW/g

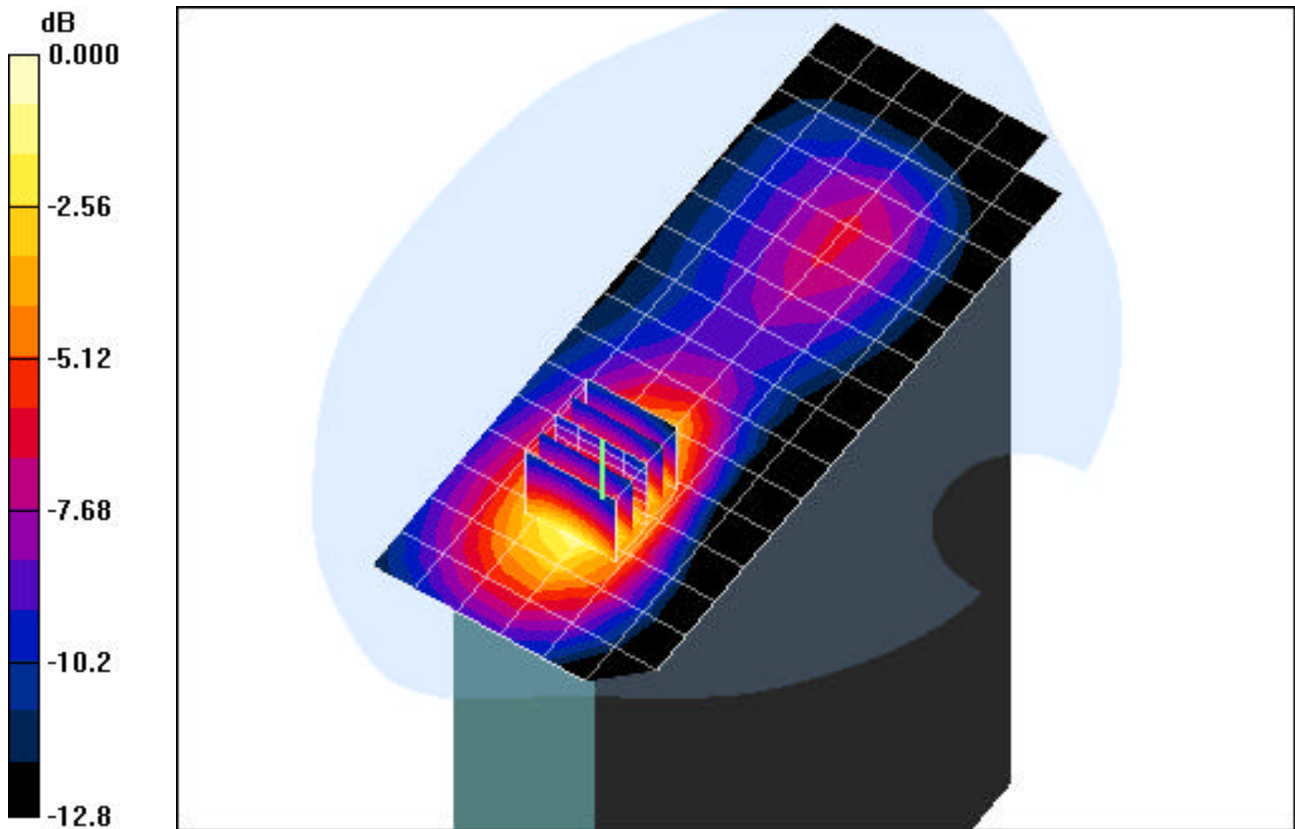

0 dB = 0.730mW/g

PCTEST ENGINEERING LABORATORY, INC.

DUT: CF -18; Type: Notebook PC with WLANa+b+g & Bluetooth & HSDPA; SN: 5KKS50328

Communication System: GSM 850 GPRS; 2 Tx slots; Frequency: 836.6 MHz; Duty Cycle: 1:4.15

Medium: 835 Muscle ($\sigma = 0.99$ mho/m, $\epsilon_r = 54.73$, $\rho = 1000$ kg/m³)

Phantom section: Flat Section; Space: 0.0cm from DUT to Flat Phantom

Test Date: 01-09-2006; Ambient Temp: 23.5°C; Tissue Temp: 21.6°C

Probe: EX3DV4 - SN3561; ConvF(7.9, 7.9, 7.9); Calibrated: 8/24/2005

Sensor-Surface: 3mm (Mechanical Surface Detection)

Electronics: DAE4 Sn649; Calibrated: 9/13/2005

Phantom: SAM Main; Type: SAM 4.0; Serial: TP:1197

Measurement SW: DASY4, V4.6 Build 19; Postprocessing SW: SEMCAD, V1.8 Build 159

Laptop Position, LCD Flip, Ch.190

Area Scan (7x17x1): Measurement grid: dx=15mm, dy=15mm

Zoom Scan (5x5x7)/Cube 0: Measurement grid: dx=8mm, dy=8mm, dz=5mm

Reference Value = 5.01 V/m

Peak SAR (extrapolated) = 0.224 W/kg

SAR(1 g) = 0.146 mW/g; SAR(10 g) = 0.096 mW/g

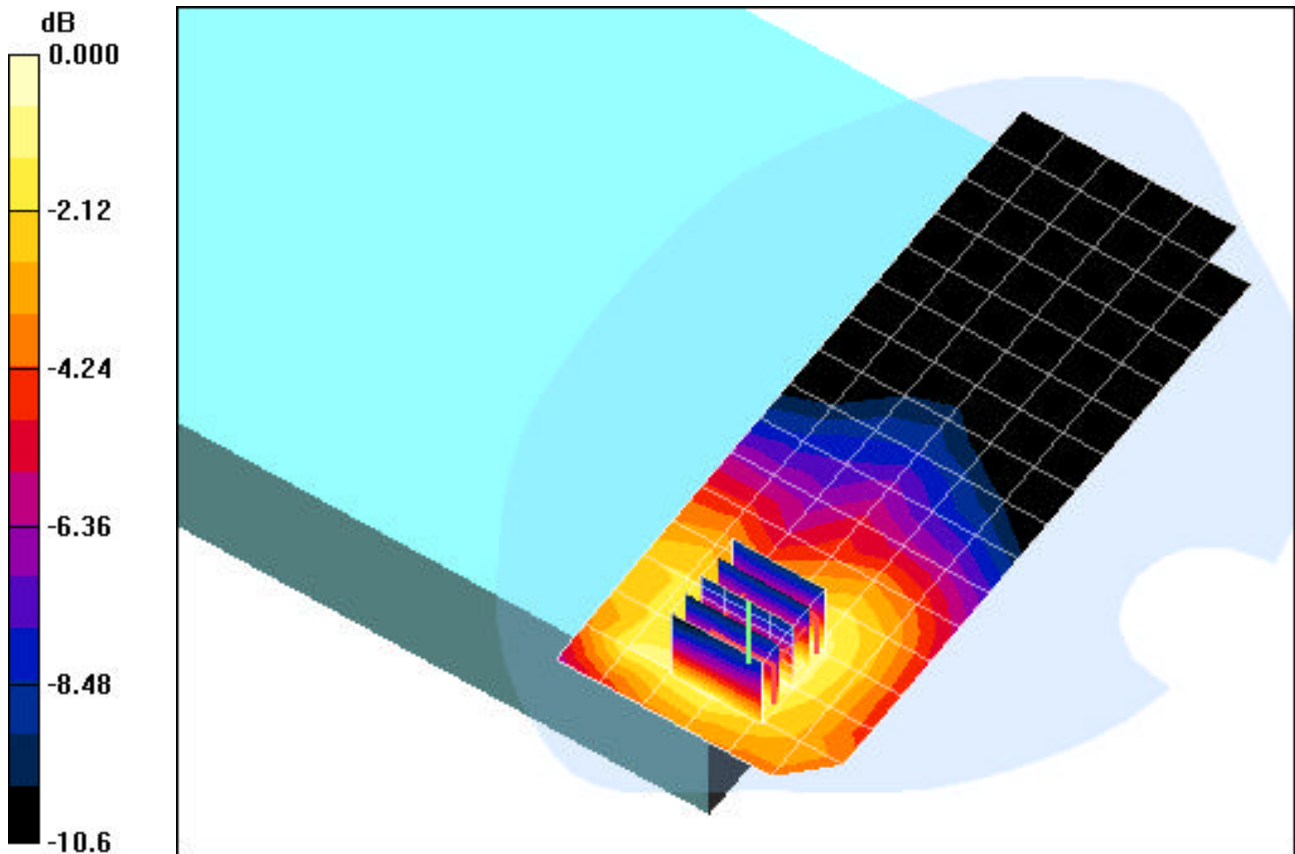

0 dB = 0.173mW/g

PCTEST ENGINEERING LABORATORY, INC.

DUT: CF-18; Type: Notebook PC with WLANa+b+g & Bluetooth 7 HSDPA; SN: 5KKS50328

Communication System: GSM1900 GPRS; Frequency: 1880 MHz; Duty Cycle: 1:4.15

Medium: 1900 Muscle ($\sigma = 1.57$ mho/m, $\epsilon_r = 52.8$, $\rho = 1000$ kg/m³)

Phantom section: Flat Section; Space: 0.0cm from DUT to Flat Phantom

Test Date: 01-09-2006; Ambient Temp: 23.5°C; Tissue Temp: 21.6°C

Probe: EX3DV4 - SN3561; ConvF(6.48, 6.48, 6.48); Calibrated: 8/24/2005

Sensor-Surface: 3mm (Mechanical Surface Detection)

Electronics: DAE4 Sn649; Calibrated: 9/13/2005

Phantom: SAM Sub; Type: SAM 4.0; Serial: TP:1357

Measurement SW: DASY4, V4.6 Build 19; Postprocessing SW: SEMCAD, V1.8 Build 159

Bystander position, LCD Open, Ch.661, w/ WLAN 802.11b, Ch.06, 5.5mbps

Area Scan (5x17x1): Measurement grid: dx=15mm, dy=15mm

Zoom Scan (5x5x7)/Cube 0: Measurement grid: dx=8mm, dy=8mm, dz=5mm

Reference Value = 9.20 V/m

Peak SAR (extrapolated) = 0.596 W/kg

SAR(1 g) = 0.350 mW/g; SAR(10 g) = 0.194 mW/g

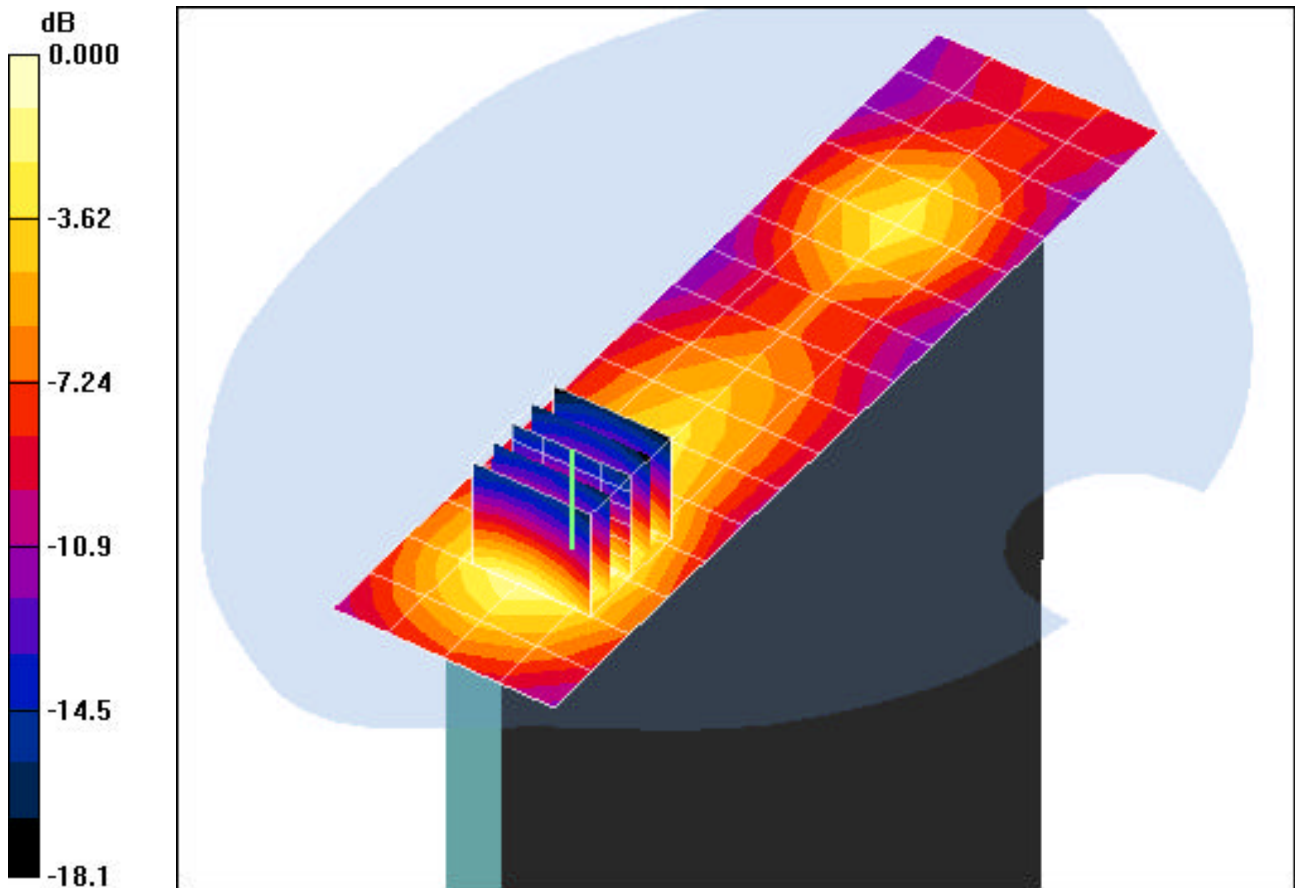

0 dB = 0.429mW/g

PCTEST ENGINEERING LABORATORY, INC.

DUT: CF-18; Type: Notebook PC with WLANa+b+g & Bluetooth & HSDPA; SN: 5KKS50328

Communication System: GSM1900 GPRS; Frequency: 1880 MHz; Duty Cycle: 1:4.15

Medium: 1900 Muscle ($\sigma = 1.57$ mho/m, $\epsilon_r = 52.8$, $\rho = 1000$ kg/m³)

Phantom section: Flat Section; Space: 0.0cm from DUT to Flat Phantom

Test Date: 01-09-2006; Ambient Temp: 23.5°C; Tissue Temp: 21.6°C

Probe: EX3DV4 - SN3561; ConvF(6.48, 6.48, 6.48); Calibrated: 8/24/2005

Sensor-Surface: 3mm (Mechanical Surface Detection)

Electronics: DAE4 Sn649; Calibrated: 9/13/2005

Phantom: SAM Sub; Type: SAM 4.0; Serial: TP:1357

Measurement SW: DASY4, V4.6 Build 19; Postprocessing SW: SEMCAD, V1.8 Build 159

Tablet Position, LCD Flip, Ch.661, w/ WLAN 802.11b, Ch.06, 5.5mbps

Area Scan (7x17x1): Measurement grid: dx=15mm, dy=15mm

Zoom Scan (5x5x7)/Cube 0: Measurement grid: dx=8mm, dy=8mm, dz=5mm

Reference Value = 6.28 V/m

Peak SAR (extrapolated) = 0.590 W/kg

SAR(1 g) = 0.343 mW/g; SAR(10 g) = 0.192 mW/g

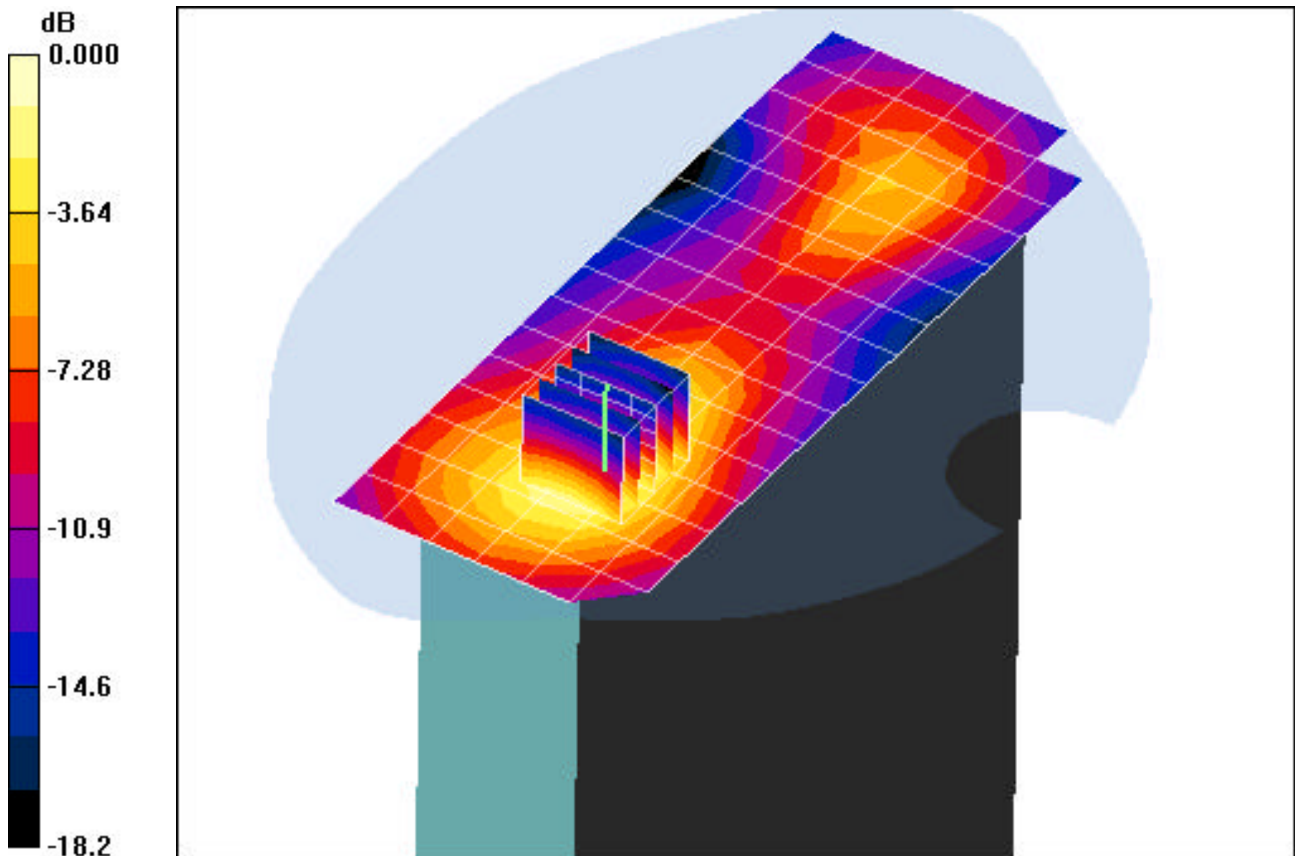

0 dB = 0.420mW/g

PCTEST ENGINEERING LABORATORY, INC.

DUT: CF-18; Type: Notebook PC with WLANa+b+g & Bluetooth & HSDPA; SN: 5KKS50328

Communication System: GSM1900 GPRS; Frequency: 1880 MHz; Duty Cycle: 1:4.15

Medium: 1900 Muscle ($\sigma = 1.57$ mho/m, $\epsilon_r = 52.8$, $\rho = 1000$ kg/m³)

Phantom section: Flat Section; Space: 0.0cm from DUT to Flat Phantom

Test Date: 01-09-2006; Ambient Temp: 23.5°C; Tissue Temp: 21.6°C

Probe: EX3DV4 - SN3561; ConvF(6.48, 6.48, 6.48); Calibrated: 8/24/2005

Sensor-Surface: 3mm (Mechanical Surface Detection)

Electronics: DAE4 Sn649; Calibrated: 9/13/2005

Phantom: SAM Sub; Type: SAM 4.0; Serial: TP:1357

Measurement SW: DASY4, V4.6 Build 19; Postprocessing SW: SEMCAD, V1.8 Build 159

Laptop Position, LCD Flip, Ch.661

Area Scan (7x17x1): Measurement grid: dx=15mm, dy=15mm

Zoom Scan (5x5x7)/Cube 0: Measurement grid: dx=8mm, dy=8mm, dz=5mm

Reference Value = 1.94 V/m

Peak SAR (extrapolated) = 0.089 W/kg

SAR(1 g) = 0.051 mW/g; SAR(10 g) = 0.029 mW/g

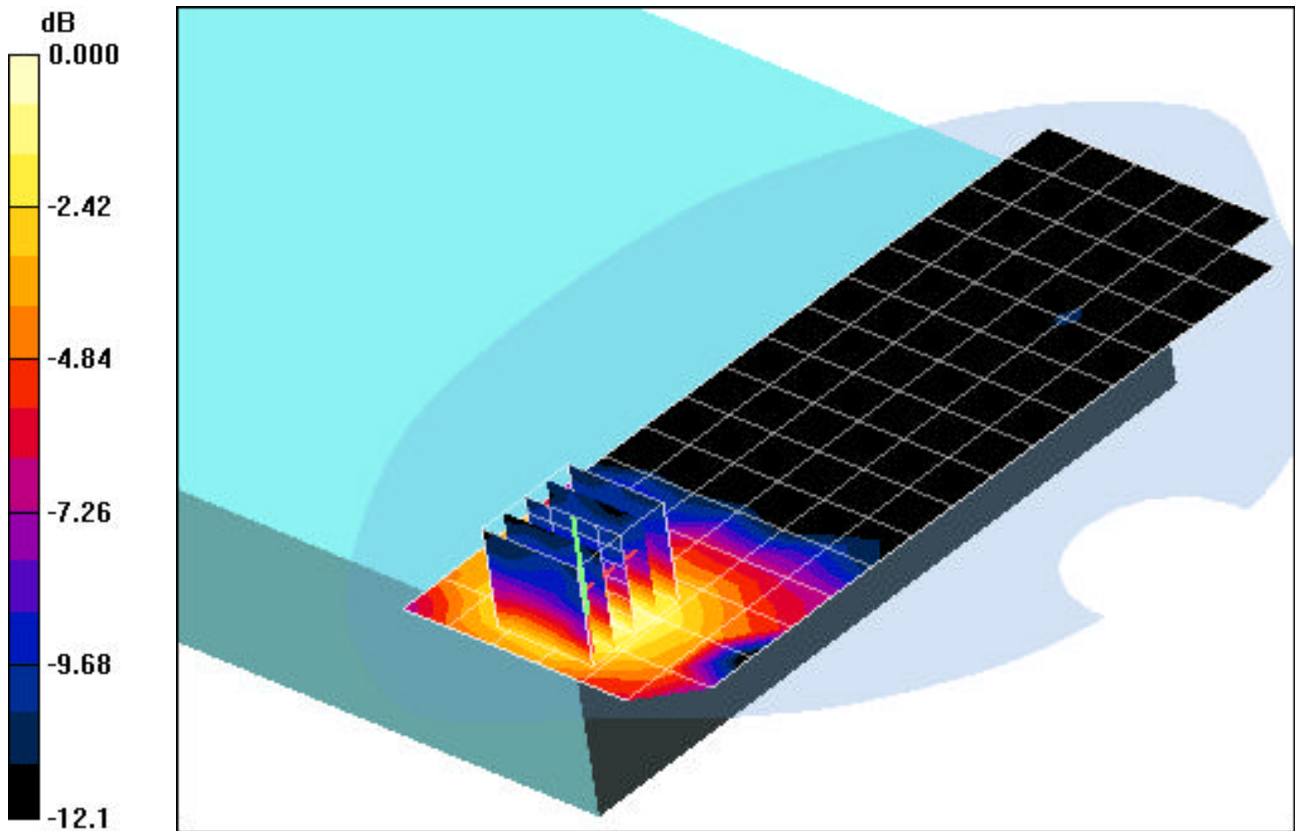

0 dB = 0.062mW/g

PCTEST ENGINEERING LABORATORY, INC.

DUT: CF -18; Type: Notebook PC with WLANa+b+g & Bluetooth & HSDPA; SN: 5KKS50328

Communication System: WCDMA850; Frequency: 836.4 MHz; Duty Cycle: 1:1

Medium: 835 Muscle ($\sigma = 0.99$ mho/m, $\epsilon_r = 54.73$, $\rho = 1000$ kg/m³)

Phantom section: Flat Section; Space: 0.0cm from DUT to Flat Phantom

Test Date: 01-10-2006; Ambient Temp: 23.6°C; Tissue Temp: 21.7°C

Probe: EX3DV4 - SN3561; ConvF(7.9, 7.9, 7.9); Calibrated: 8/24/2005

Sensor-Surface: 3mm (Mechanical Surface Detection)

Electronics: DAE4 Sn649; Calibrated: 9/13/2005

Phantom: SAM Main; Type: SAM 4.0; Serial: TP:1197

Measurement SW: DASY4, V4.6 Build 19; Postprocessing SW: SEMCAD, V1.8 Build 159

Bystander position, LCD Open, Ch.4182, w/ WLAN 802.11b, Ch.06, 5.5mbps

Area Scan (5x17x1): Measurement grid: dx=15mm, dy=15mm

Zoom Scan (5x5x7)/Cube 0: Measurement grid: dx=8mm, dy=8mm, dz=5mm

Reference Value = 6.54 V/m

Peak SAR (extrapolated) = 0.311 W/kg

SAR(1 g) = 0.201 mW/g; SAR(10 g) = 0.126 mW/g

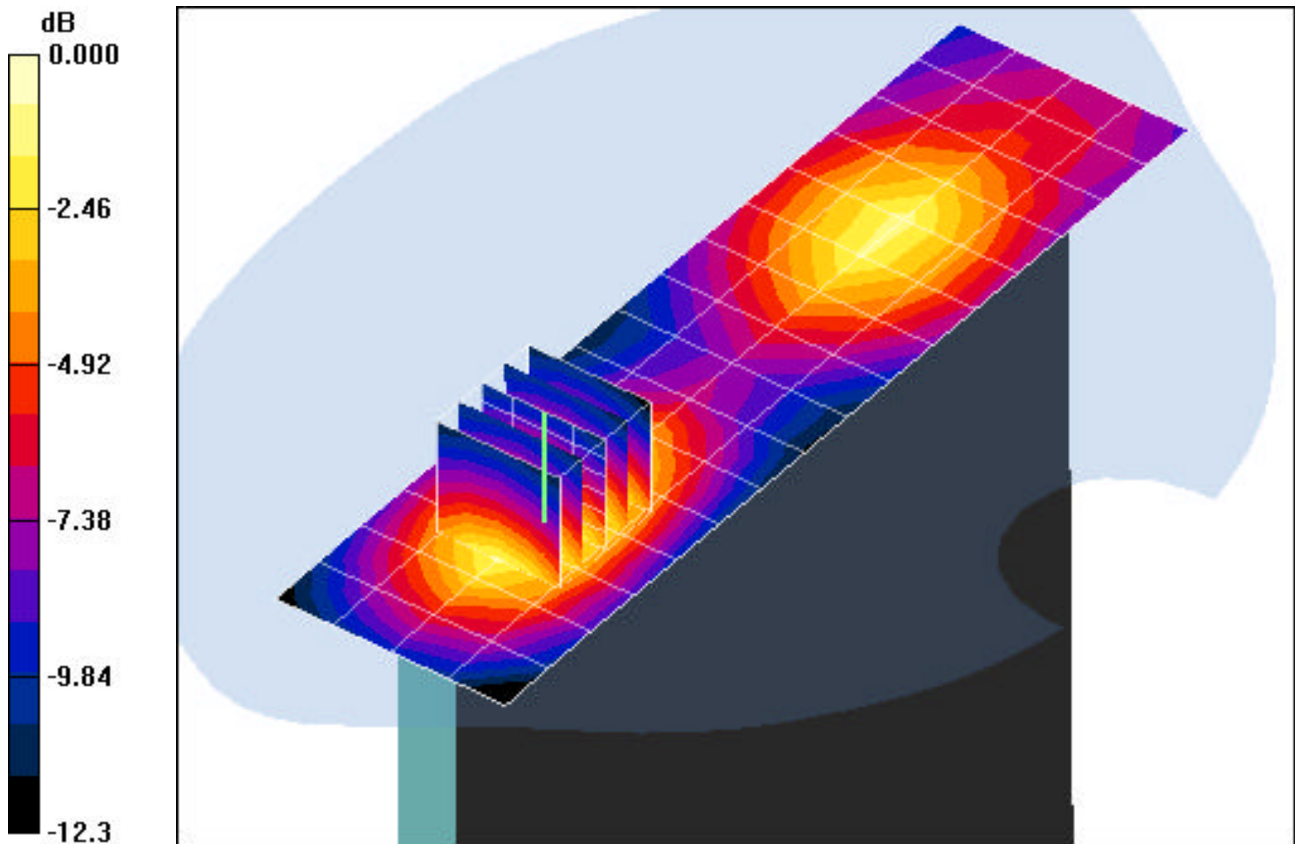

0 dB = 0.239mW/g

PCTEST ENGINEERING LABORATORY, INC.

DUT: CF-18; Type: Notebook PC with WLANa+b+g & Bluetooth & HSDPA; SN: 5KKS50328

Communication System: WCDMA850; Frequency: 836.4 MHz; Duty Cycle: 1:1

Medium: 835 Muscle ($\sigma = 0.99$ mho/m, $\epsilon_r = 54.73$, $\rho = 1000$ kg/m³)

Phantom section: Flat Section; Space: 0.0cm from DUT to Flat Phantom

Test Date: 01-10-2006; Ambient Temp: 23.6°C; Tissue Temp: 21.7°C

Probe: EX3DV4 - SN3561; ConvF(7.9, 7.9, 7.9); Calibrated: 8/24/2005

Sensor-Surface: 3mm (Mechanical Surface Detection)

Electronics: DAE4 Sn649; Calibrated: 9/13/2005

Phantom: SAM Main; Type: SAM 4.0; Serial: TP:1197

Measurement SW: DASY4, V4.6 Build 19; Postprocessing SW: SEMCAD, V1.8 Build 159

Tablet position, LCD Open, Ch.4182, w/ WLAN 802.11b, Ch.06, 5.5mbps

Area Scan (7x17x1): Measurement grid: dx=15mm, dy=15mm

Zoom Scan (5x5x7)/Cube 0: Measurement grid: dx=8mm, dy=8mm, dz=5mm

Reference Value = 6.85 V/m

Peak SAR (extrapolated) = 0.353 W/kg

SAR(1 g) = 0.230 mW/g; SAR(10 g) = 0.144 mW/g

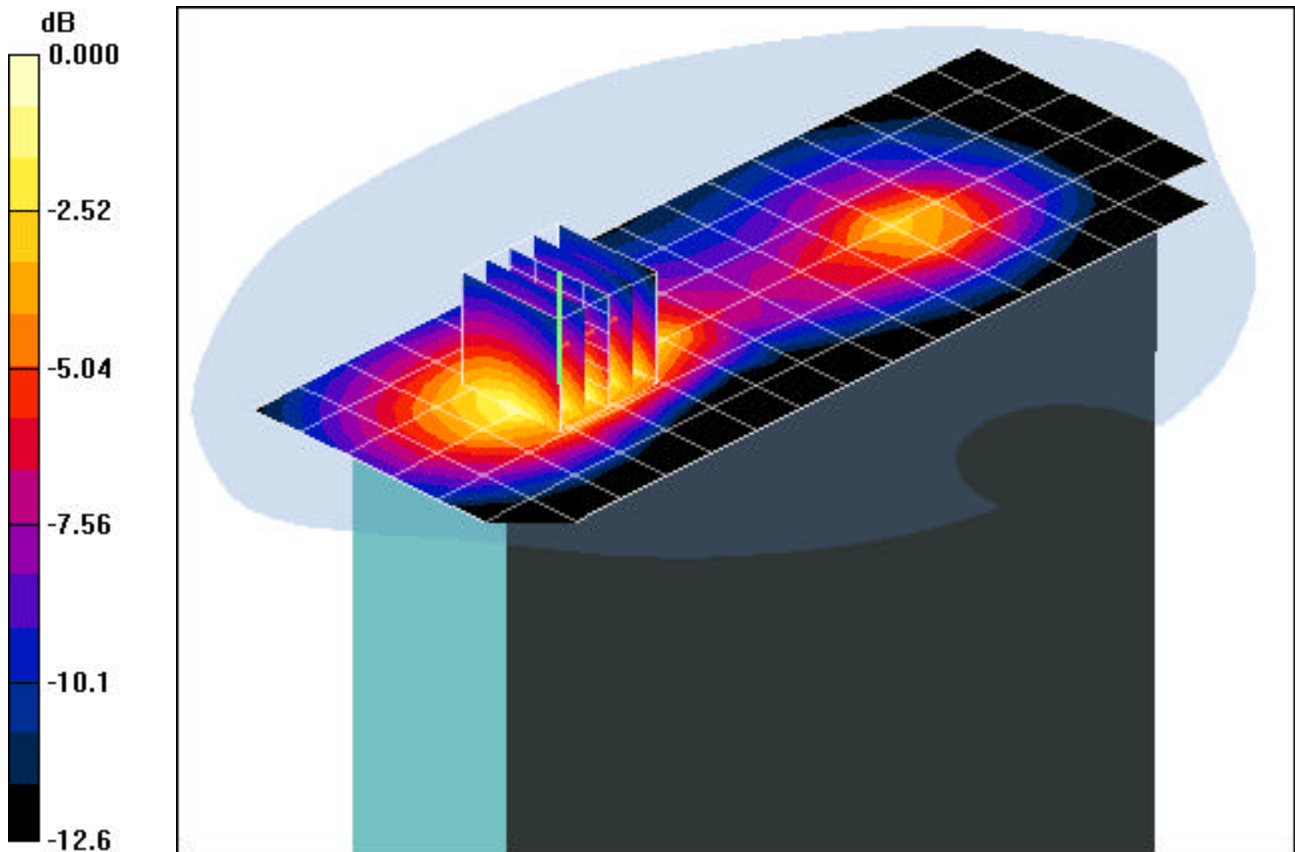

0 dB = 0.271mW/g

PCTEST ENGINEERING LABORATORY, INC.

DUT: CF -18; Type: Notebook PC with WLANa+b+g & Bluetooth & HSDPA; SN: 5KKS50328

Communication System: WCDMA850; Frequency: 836.4 MHz; Duty Cycle: 1:1

Medium: 835 Muscle ($\sigma = 0.99$ mho/m, $\epsilon_r = 54.73$, $\rho = 1000$ kg/m³)

Phantom section: Flat Section; Space: 0.0cm from DUT to Flat Phantom

Test Date: 01-10-2006; Ambient Temp: 23.6°C; Tissue Temp: 21.7°C

Probe: EX3DV4 - SN3561; ConvF(7.9, 7.9, 7.9); Calibrated: 8/24/2005

Sensor-Surface: 3mm (Mechanical Surface Detection)

Electronics: DAE4 Sn649; Calibrated: 9/13/2005

Phantom: SAM Main; Type: SAM 4.0; Serial: TP:1197

Measurement SW: DASY4, V4.6 Build 19; Postprocessing SW: SEMCAD, V1.8 Build 159

Laptop Position, LCD Flip, Ch.4182, w/ WLAN 802.11b, Ch.06, 5.5mbps

Area Scan (7x17x1): Measurement grid: dx=15mm, dy=15mm

Zoom Scan (5x5x7)/Cube 0: Measurement grid: dx=8mm, dy=8mm, dz=5mm

Reference Value = 2.74 V/m

Peak SAR (extrapolated) = 0.040 W/kg

SAR(1 g) = 0.026 mW/g; SAR(10 g) = 0.018 mW/g

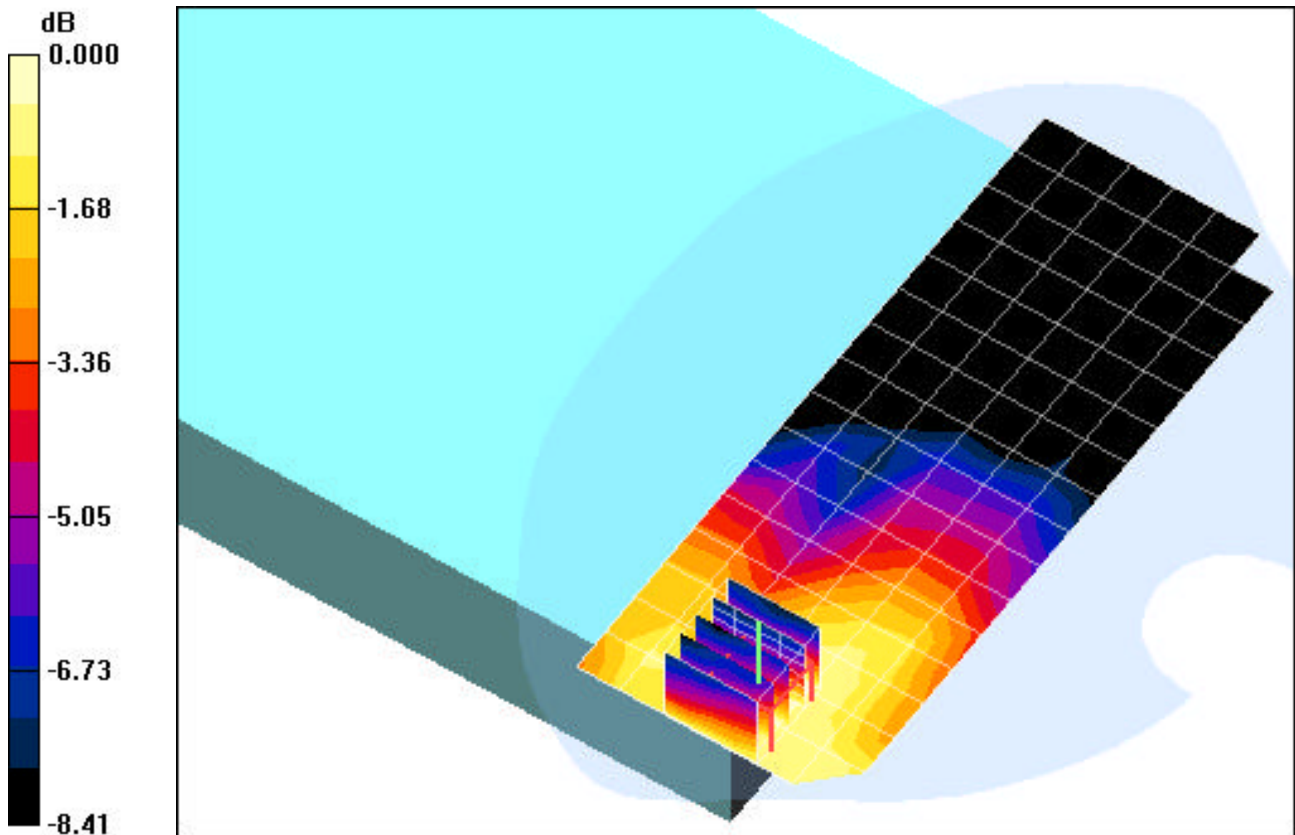

0 dB = 0.030mW/g

PCTEST ENGINEERING LABORATORY, INC.

DUT: CF-18; Type: Notebook PC with WLANa+b+g & Bluetooth & HSDPA; SN: 5KKS50328

Communication System: WCDMA1900; Frequency: 1880 MHz; Duty Cycle: 1:1

Medium: 1900 Muscle ($\sigma = 1.57$ mho/m, $\epsilon_r = 52.8$, $\rho = 1000$ kg/m³)

Phantom section: Flat Section; Space: 0.0cm from DUT to Flat Phantom

Test Date: 01-10-2006; Ambient Temp: 23.6°C; Tissue Temp: 21.7°C

Probe: EX3DV4 - SN3561; ConvF(6.48, 6.48, 6.48); Calibrated: 8/24/2005

Sensor-Surface: 3mm (Mechanical Surface Detection)

Electronics: DAE4 Sn649; Calibrated: 9/13/2005

Phantom: SAM Sub; Type: SAM 4.0; Serial: TP:1357

Measurement SW: DASY4, V4.6 Build 19; Postprocessing SW: SEMCAD, V1.8 Build 159

Bystander position, LCD Open, Ch.9400, w/ WLAN 802.11b, Ch.06, 5.5mbps

Area Scan (5x17x1): Measurement grid: dx=15mm, dy=15mm

Zoom Scan (5x5x7)/Cube 0: Measurement grid: dx=8mm, dy=8mm, dz=5mm

Reference Value = 8.24 V/m

Peak SAR (extrapolated) = 0.405 W/kg

SAR(1 g) = 0.236 mW/g; SAR(10 g) = 0.132 mW/g

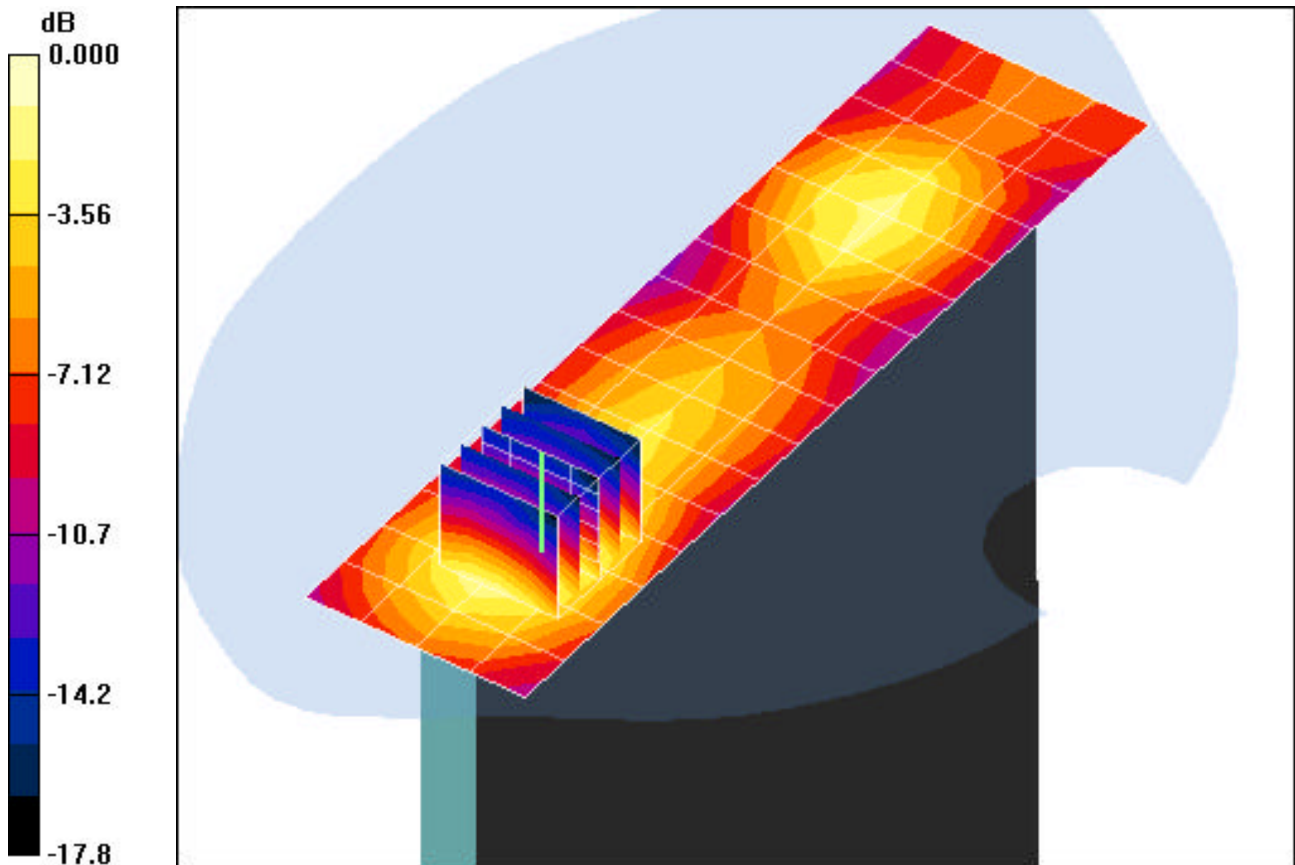

0 dB = 0.291mW/g

PCTEST ENGINEERING LABORATORY, INC.

DUT: CF-18; Type: Notebook PC with WLANa+b+g & Bluetooth & HSDPA; SN: 5KKS50328

Communication System: WCDMA1900; Frequency: 1880 MHz; Duty Cycle: 1:4.15

Medium: 1900 Muscle ($\sigma = 1.57$ mho/m, $\epsilon_r = 52.8$, $\rho = 1000$ kg/m³)

Phantom section: Flat Section; Space: 0.0cm from DUT to Flat Phantom

Test Date: 01-10-2006; Ambient Temp: 23.6°C; Tissue Temp: 21.7°C

Probe: EX3DV4 - SN3561; ConvF(6.48, 6.48, 6.48); Calibrated: 8/24/2005

Sensor-Surface: 3mm (Mechanical Surface Detection)

Electronics: DAE4 Sn649; Calibrated: 9/13/2005

Phantom: SAM Sub; Type: SAM 4.0; Serial: TP:1357

Measurement SW: DASY4, V4.6 Build 19; Postprocessing SW: SEMCAD, V1.8 Build 159

Tablet position, LCD Open, Ch.9400, w/ WLAN 802.11a, Ch.52, 18mbps

Area Scan (7x17x1): Measurement grid: dx=15mm, dy=15mm

Zoom Scan (5x5x7)/Cube 0: Measurement grid: dx=8mm, dy=8mm, dz=5mm

Reference Value = 4.72 V/m

Peak SAR (extrapolated) = 0.389 W/kg

SAR(1 g) = 0.227 mW/g; SAR(10 g) = 0.128 mW/g

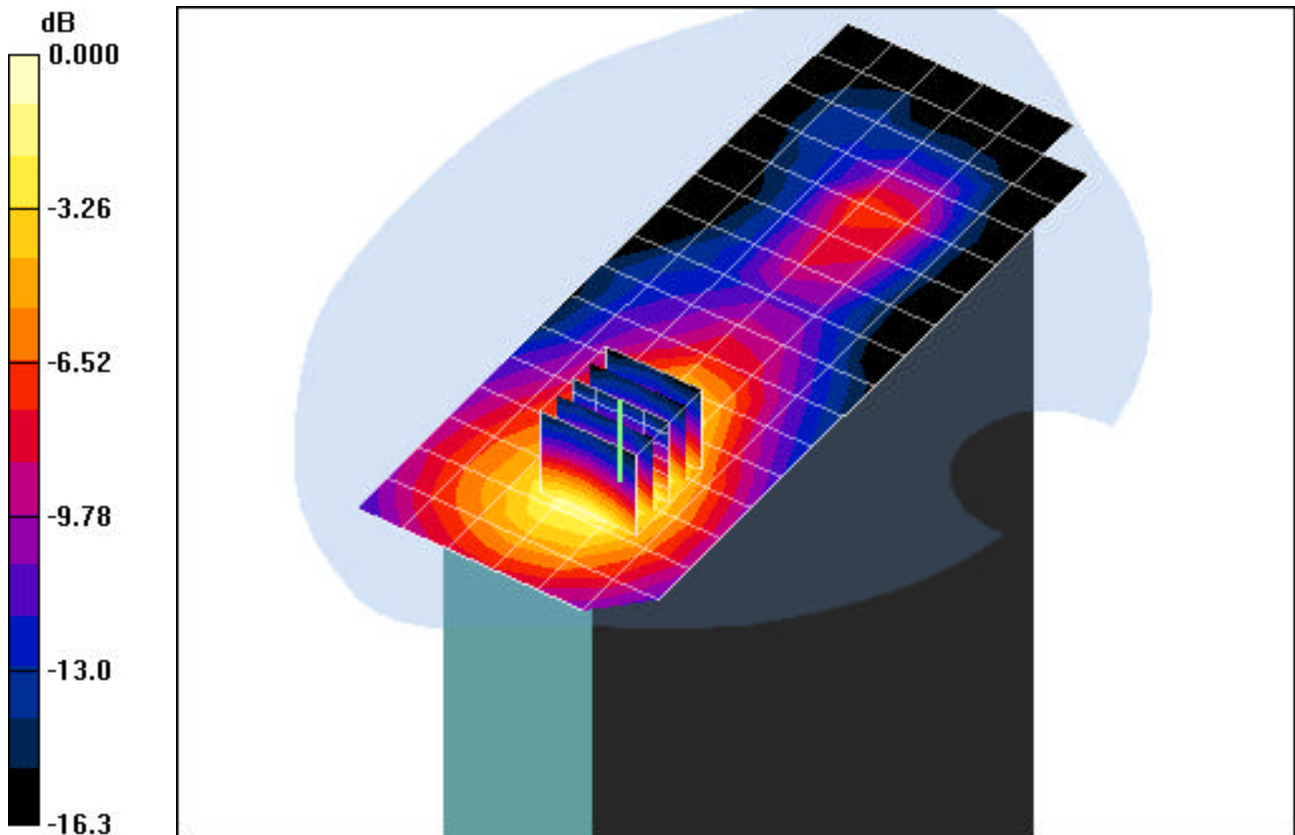

0 dB = 0.279mW/g

PCTEST ENGINEERING LABORATORY, INC.

DUT: CF -18; Type: Notebook PC with WLANa+b+g & Bluetooth & HSDPA; SN: 5KKS50328

Communication System: WCDMA1900; Frequency: 1880 MHz; Duty Cycle: 1:1

Medium: 1900 Muscle ($\sigma = 1.57$ mho/m, $\epsilon_r = 52.8$, $\rho = 1000$ kg/m³)

Phantom section: Flat Section; Space: 0.0cm from DUT to Flat Phantom

Test Date: 01-10-2006; Ambient Temp: 23.6°C; Tissue Temp: 21.7°C

Probe: EX3DV4 - SN3561; ConvF(6.48, 6.48, 6.48); Calibrated: 8/24/2005

Sensor-Surface: 3mm (Mechanical Surface Detection)

Electronics: DAE4 Sn649; Calibrated: 9/13/2005

Phantom: SAM Sub; Type: SAM 4.0; Serial: TP:1357

Measurement SW: DASY4, V4.6 Build 19; Postprocessing SW: SEMCAD, V1.8 Build 159

Laptop Position, LCD Flip, Ch.9400

Area Scan (7x17x1): Measurement grid: dx=15mm, dy=15mm

Zoom Scan (5x5x7)/Cube 0: Measurement grid: dx=8mm, dy=8mm, dz=5mm

Reference Value = 1.33 V/m

Peak SAR (extrapolated) = 0.065 W/kg

SAR(1 g) = 0.037 mW/g; SAR(10 g) = 0.022 mW/g

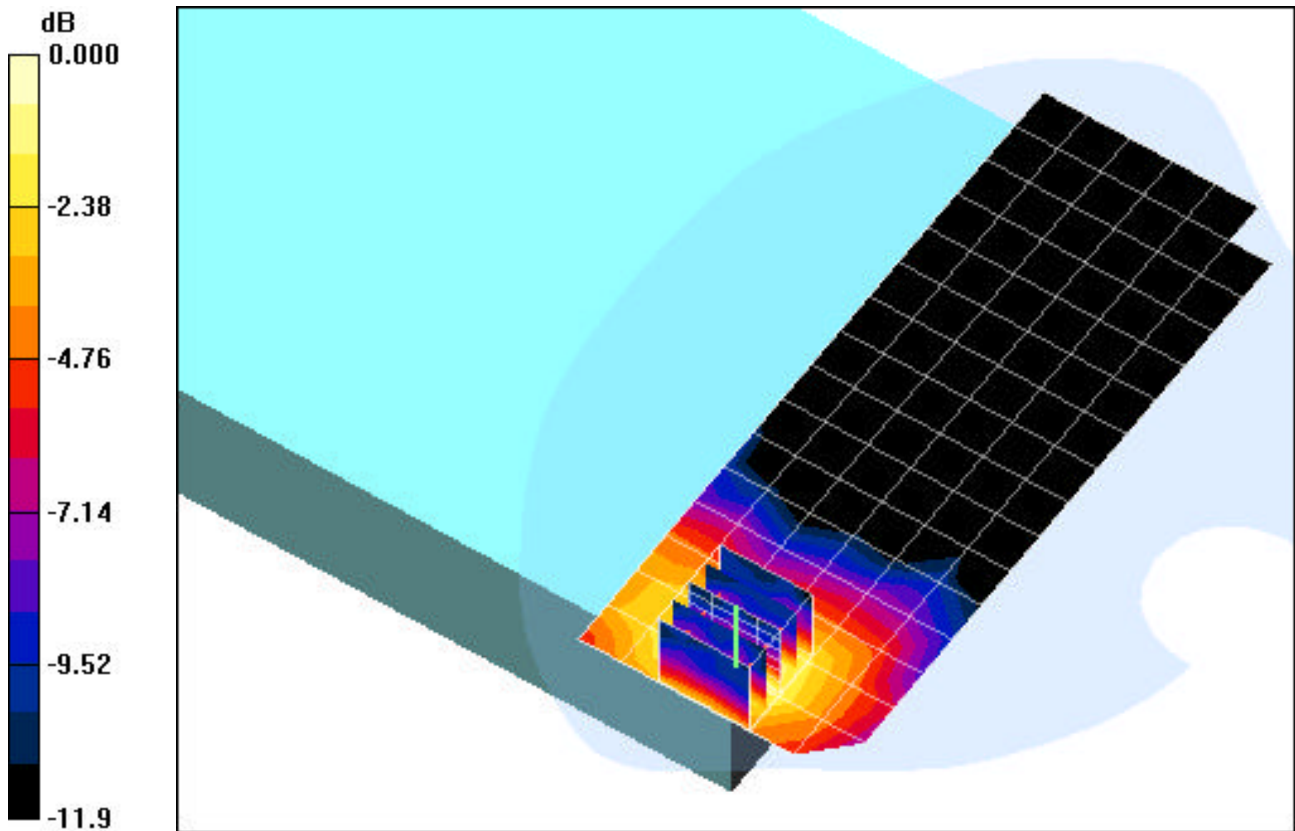

0 dB = 0.046mW/g

PCTEST ENGINEERING LABORATORY, INC.

DUT: CF-18; Type: Notebook PC with WLAN+a+b+g & Bluetooth & HSDPA; SN: 5KKS50328

Communication System: IEEE 802.11b; Frequency: 2437 MHz; Duty Cycle: 1:1

Medium: 2450 Muscle ($\sigma = 1.93 \text{ mho/m}$, $\epsilon_r = 54.0$, $\rho = 1000 \text{ kg/m}^3$)

Phantom section: Flat Section; Space: 0.0cm from DUT to Flat Phantom

Test Date: 01-04-2006; Ambient Temp: 23.4°C; Tissue Temp: 21.5°C

Probe: EX3DV4 - SN3561; ConvF(6.3, 6.3, 6.3); Calibrated: 8/24/2005

Sensor-Surface: 3mm (Mechanical Surface Detection)

Electronics: DAE4 Sn649; Calibrated: 9/13/2005

Phantom: SAM Main; Type: SAM 4.0; Serial: TP:1197

Measurement SW: DASY4, V4.6 Build 19; Postprocessing SW: SEMCAD, V1.8 Build 159

Bystander position, LCD Open, Ch.06, 5.5Mbps, Main Antenna, Bluetooth Off

Area Scan (5x17x1): Measurement grid: dx=15mm, dy=15mm

Zoom Scan (5x5x7)/Cube 0: Measurement grid: dx=8mm, dy=8mm, dz=5mm

Reference Value = 2.35 V/m

Peak SAR (extrapolated) = 0.317 W/kg

SAR(1 g) = 0.168 mW/g; SAR(10 g) = 0.090 mW/g

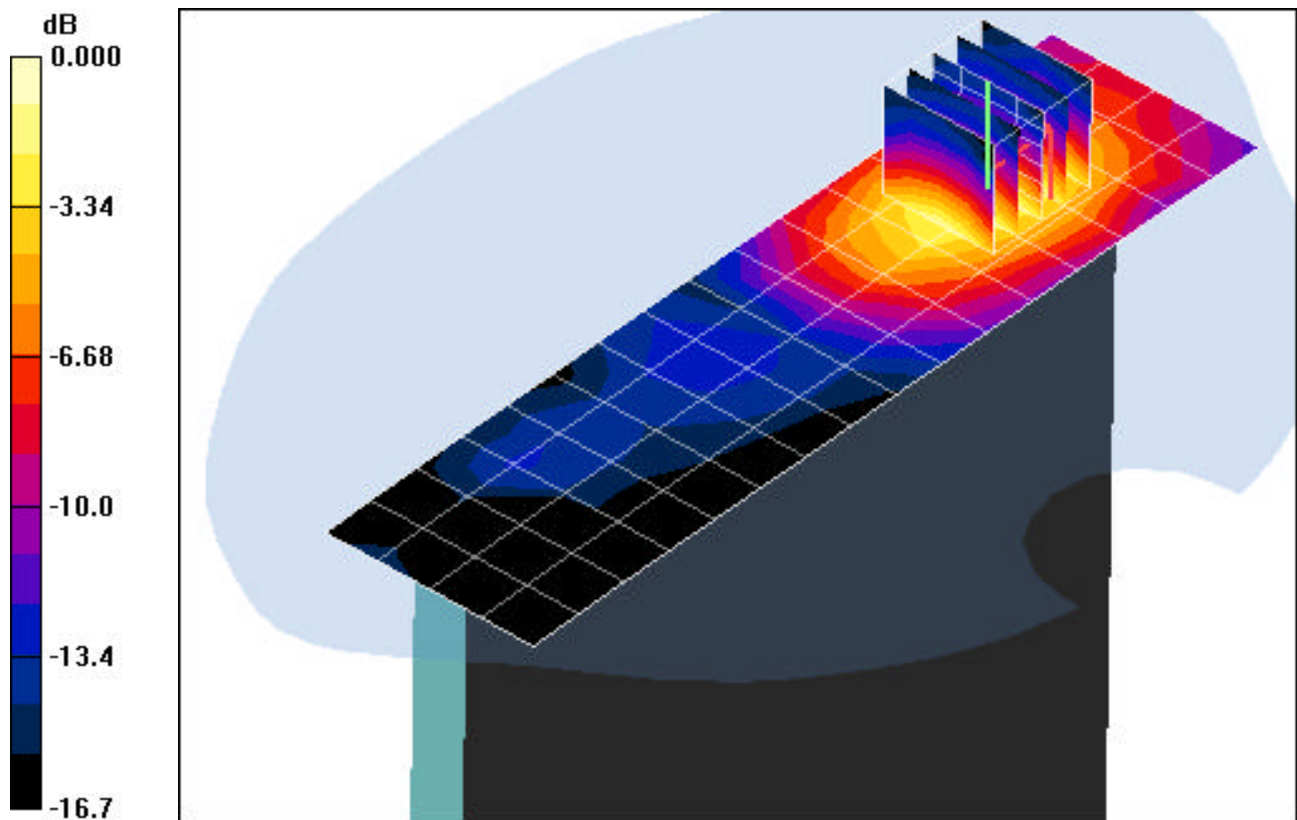

0 dB = 0.213mW/g

PCTEST ENGINEERING LABORATORY, INC.

DUT: CF-18; Type: Notebook PC with WLANa+b+g & Bluetooth & HSDPA; SN: 5KKS50328

Communication System: IEEE 802.11b; Frequency: 2437 MHz; Duty Cycle: 1:1

Medium: 2450 Muscle ($\sigma = 1.93$ mho/m, $\epsilon_r = 54.0$, $\rho = 1000$ kg/m³)

Phantom section: Flat Section; Space: 0.0cm from DUT to Flat Phantom

Test Date: 01-04-2006; Ambient Temp: 23.4°C; Tissue Temp: 21.5°C

Probe: EX3DV4 - SN3561; ConvF(6.3, 6.3, 6.3); Calibrated: 8/24/2005

Sensor-Surface: 3mm (Mechanical Surface Detection)

Electronics: DAE4 Sn649; Calibrated: 9/13/2005

Phantom: SAM Main; Type: SAM 4.0; Serial: TP:1197

Measurement SW: DASY4, V4.6 Build 19; Postprocessing SW: SEMCAD, V1.8 Build 159

Bystander position, LCD Open, Ch.06, 5.5Mbps, Aux Antenna

Area Scan (5x17x1): Measurement grid: dx=15mm, dy=15mm

Zoom Scan (5x5x7)/Cube 0: Measurement grid: dx=8mm, dy=8mm, dz=5mm

Reference Value = 2.12 V/m

Peak SAR (extrapolated) = 0.403 W/kg

SAR(1 g) = 0.217 mW/g; SAR(10 g) = 0.117 mW/g

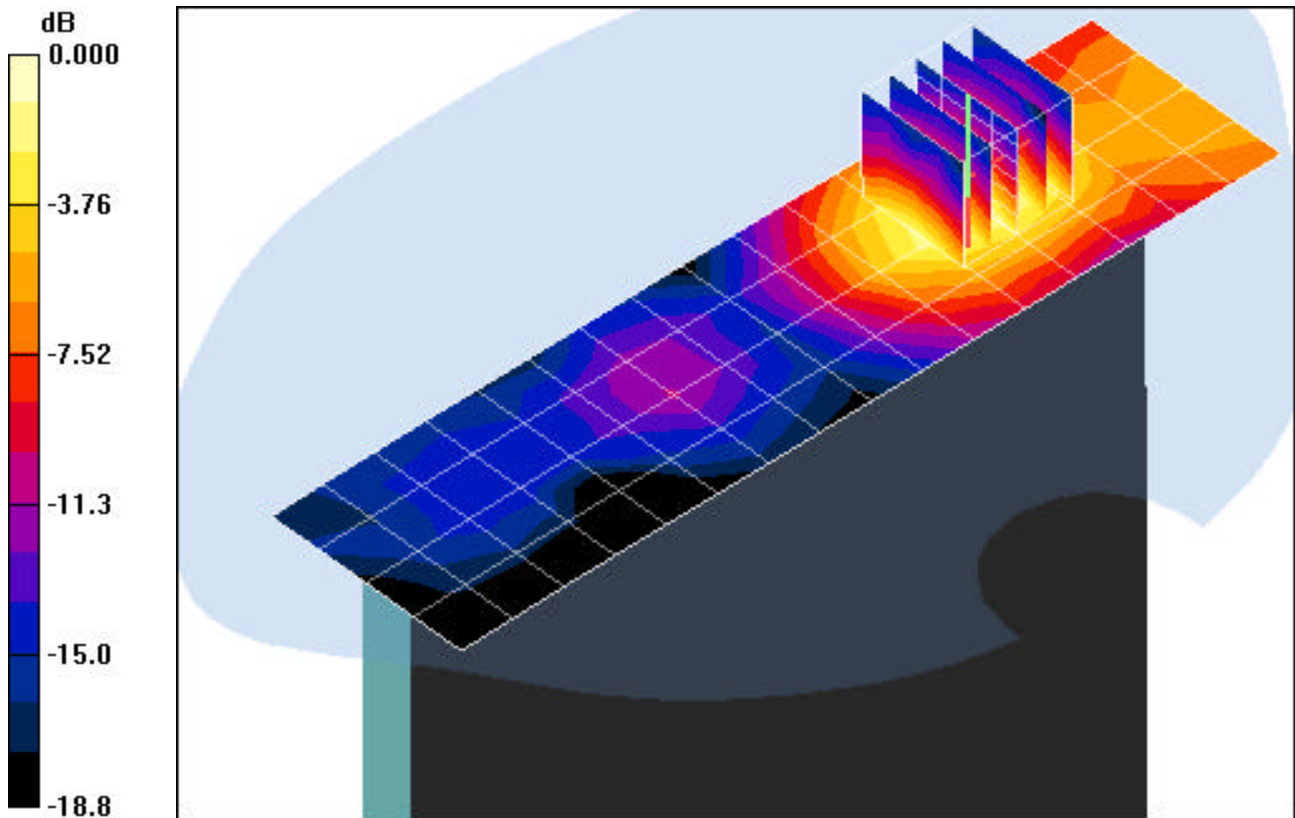

0 dB = 0.272mW/g

PCTEST ENGINEERING LABORATORY, INC.

DUT: CF-18; Type: Notebook PC with WLANa+b+g & Bluetooth & HSDPA; SN: 5KKS50328

Communication System: IEEE 802.11b; Frequency: 2437 MHz; Duty Cycle: 1:1

Medium: 2450 Muscle ($\sigma = 1.93$ mho/m, $\epsilon_r = 54.0$, $\rho = 1000$ kg/m³)

Phantom section: Flat Section; Space: 0.0cm from DUT to Flat Phantom

Test Date: 01-04-2006; Ambient Temp: 23.4°C; Tissue Temp: 21.5°C

Probe: EX3DV4 - SN3561; ConvF(6.3, 6.3, 6.3); Calibrated: 8/24/2005

Sensor-Surface: 3mm (Mechanical Surface Detection)

Electronics: DAE4 Sn649; Calibrated: DAE not calibrated

Phantom: SAM Main; Type: SAM 4.0; Serial: TP:1197

Measurement SW: DASY4, V4.6 Build 19; Postprocessing SW: SEMCAD, V1.8 Build 159

Tablet position, LCD Flip, Ch.06, 5.5Mbps, Main antenna, Bluetooth Off

Area Scan (7x17x1): Measurement grid: dx=15mm, dy=15mm

Zoom Scan (5x5x7)/Cube 0: Measurement grid: dx=8mm, dy=8mm, dz=5mm

Reference Value = 4.53 V/m

Peak SAR (extrapolated) = 0.280 W/kg

SAR(1 g) = 0.147 mW/g; SAR(10 g) = 0.079 mW/g

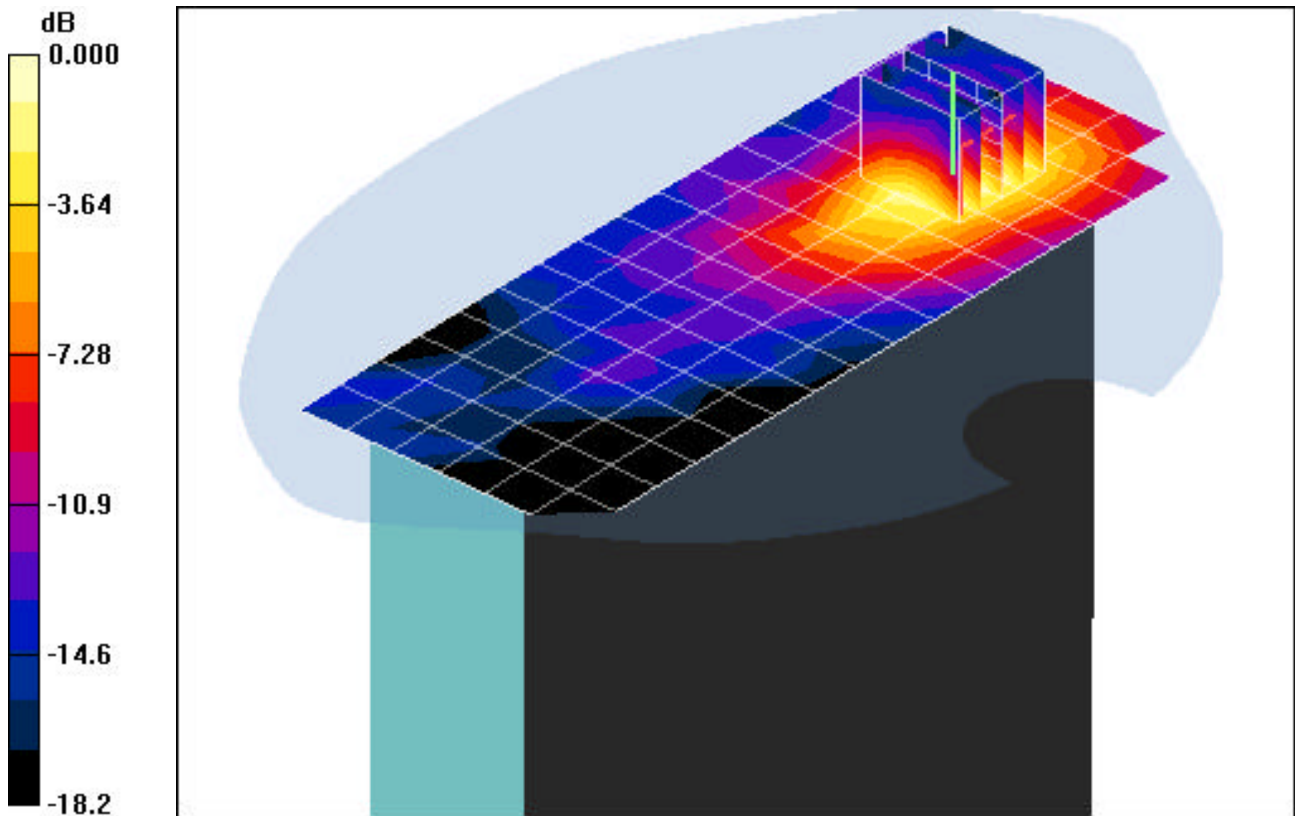

0 dB = 0.185mW/g

PCTEST ENGINEERING LABORATORY, INC.

DUT: CF -18; Type: Notebook PC with WLANa+b+g & Bluetooth & HSDPA; SN: 5KKS50328

Communication System: IEEE 802.11b; Frequency: 2437 MHz; Duty Cycle: 1:1

Medium: 2450 Muscle ($\sigma = 1.93$ mho/m, $\epsilon_r = 54.0$, $\rho = 1000$ kg/m³)

Phantom section: Flat Section; Space: 0.0cm from DUT to Flat Phantom

Test Date: 01-04-2006; Ambient Temp: 23.4°C; Tissue Temp: 21.5°C

Probe: EX3DV4 - SN3561; ConvF(6.3, 6.3, 6.3); Calibrated: 8/24/2005

Sensor-Surface: 3mm (Mechanical Surface Detection)

Electronics: DAE4 Sn649; Calibrated: DAE not calibrated

Phantom: SAM Main; Type: SAM 4.0; Serial: TP:1197

Measurement SW: DASY4, V4.6 Build 19; Postprocessing SW: SEMCAD, V1.8 Build 159

Tablet position, LCD Flip, Left side, Ch.06, 5.5Mbps, Aux Antenna

Area Scan (7x17x1): Measurement grid: dx=15mm, dy=15mm

Zoom Scan (5x5x7)/Cube 0: Measurement grid: dx=8mm, dy=8mm, dz=5mm

Reference Value = 2.49 V/m

Peak SAR (extrapolated) = 0.314 W/kg

SAR(1 g) = 0.168 mW/g; SAR(10 g) = 0.091 mW/g

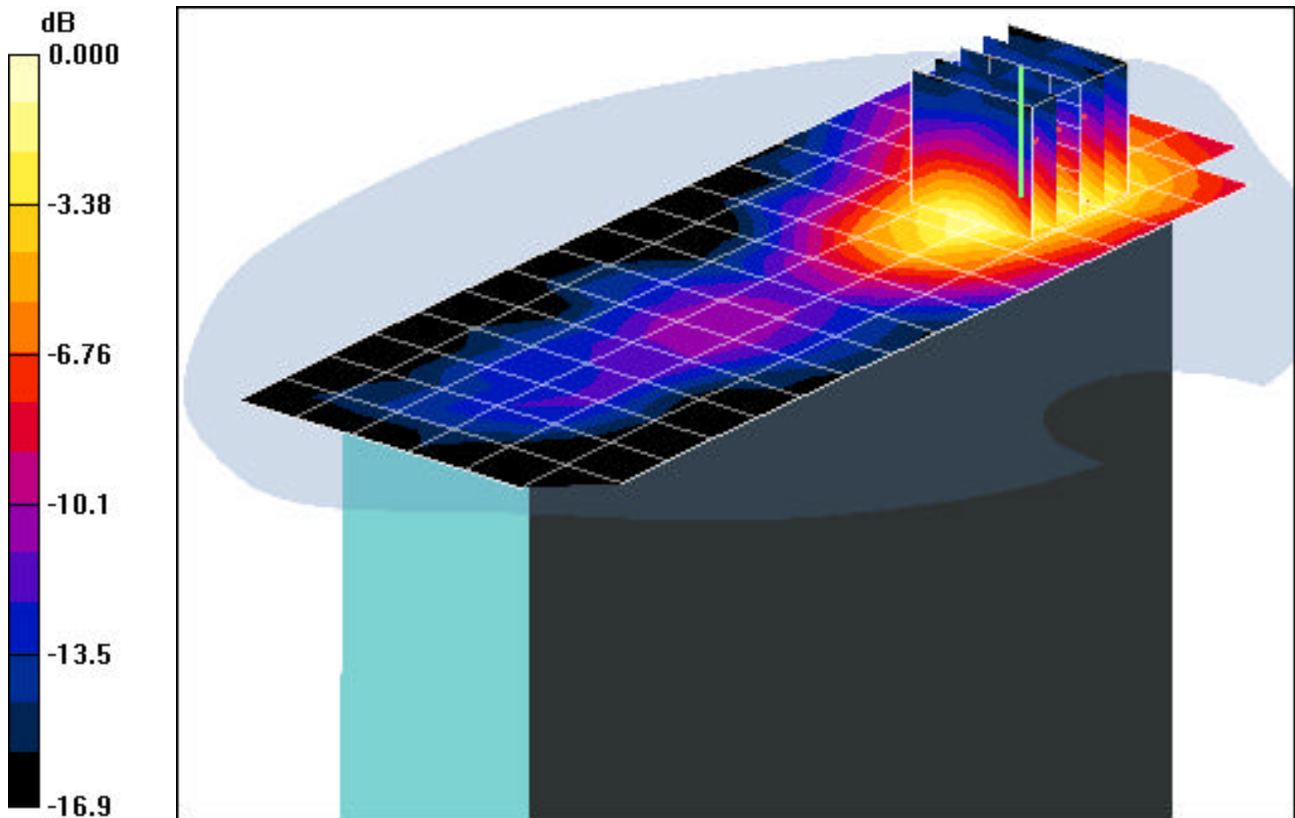

0 dB = 0.214mW/g

PCTEST ENGINEERING LABORATORY, INC.

DUT: CF-18; Type: Notebook PC with WLANa+b+g & Bluetooth & HSDPA; SN: 5KKS50328

Communication System: IEEE 802.11b; Frequency: 2437 MHz; Duty Cycle: 1:1

Medium: 2450 Muscle ($\sigma = 1.93$ mho/m, $\epsilon_r = 54.0$, $\rho = 1000$ kg/m³)

Phantom section: Flat Section; Space: 0.0cm from DUT to Flat Phantom

Test Date: 01-04-2006; Ambient Temp: 23.4°C; Tissue Temp: 21.5°C

Probe: EX3DV4 - SN3561; ConvF(6.3, 6.3, 6.3); Calibrated: 8/24/2005

Sensor-Surface: 3mm (Mechanical Surface Detection)

Electronics: DAE4 Sn649; Calibrated: DAE not calibrated

Phantom: SAM Main; Type: SAM 4.0; Serial: TP:1197

Measurement SW: DASY4, V4.6 Build 19; Postprocessing SW: SEMCAD, V1.8 Build 159

Laptop Position, LCD Flip, Ch.06, 5.5Mbps, Main antenna, Bluetooth Off

Area Scan (7x17x1): Measurement grid: dx=15mm, dy=15mm

Zoom Scan (5x5x7)/Cube 0: Measurement grid: dx=8mm, dy=8mm, dz=5mm

Reference Value = 0.952 V/m

Peak SAR (extrapolated) = 0.038 W/kg

SAR(1 g) = 0.019 mW/g; SAR(10 g) = 0.011 mW/g

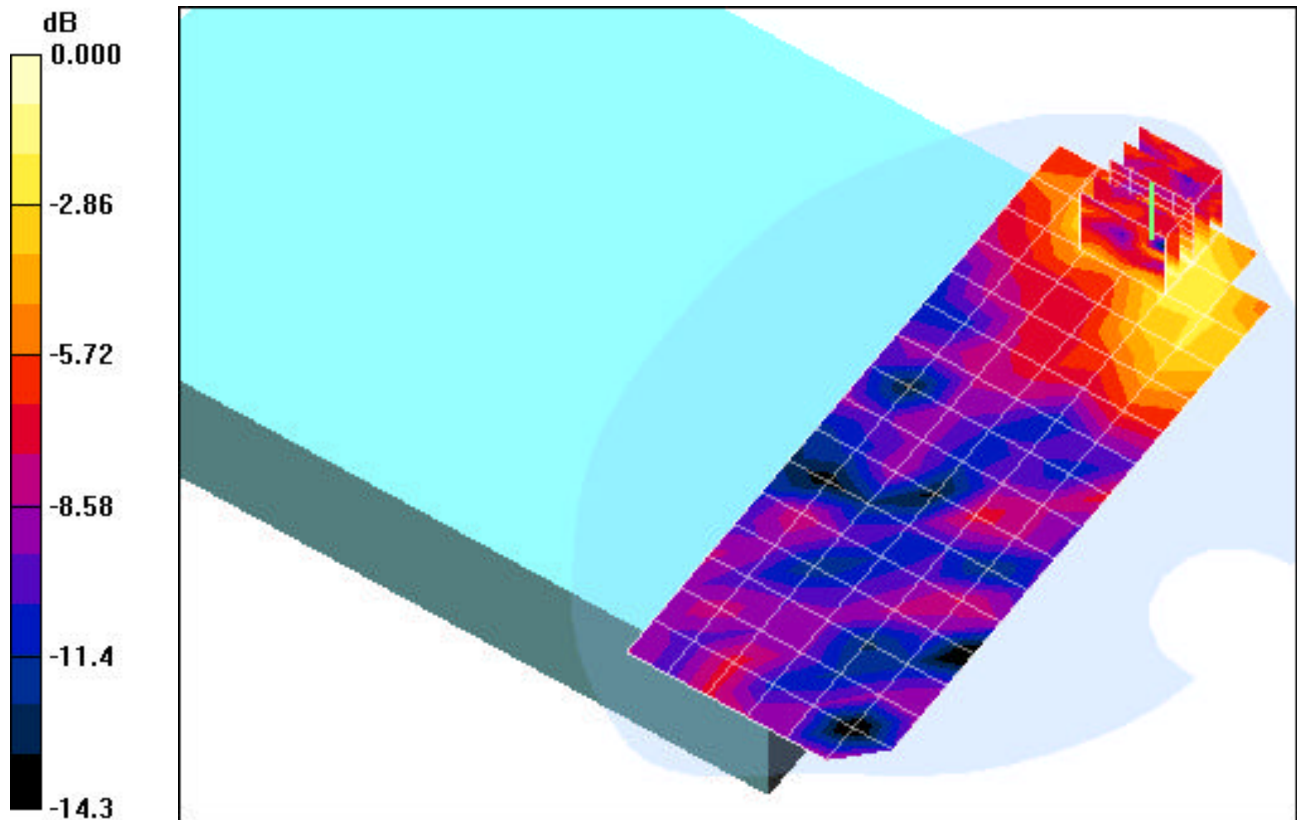

0 dB = 0.023mW/g

PCTEST ENGINEERING LABORATORY, INC.

DUT: CF -18; Type: Notebook PC with WLANa+b+g & Bluetooth & HSDPA; SN: 5KKS50328

Communication System: IEEE 802.11b; Frequency: 2437 MHz; Duty Cycle: 1:1

Medium: 2450 Muscle ($\sigma = 1.93$ mho/m, $\epsilon_r = 54.0$, $\rho = 1000$ kg/m³)

Phantom section: Flat Section; Space: 0.0cm from DUT to Flat Phantom

Test Date: 01-04-2006; Ambient Temp: 23.4°C; Tissue Temp: 21.5°C

Probe: EX3DV4 - SN3561; ConvF(6.3, 6.3, 6.3); Calibrated: 8/24/2005

Sensor-Surface: 3mm (Mechanical Surface Detection)

Electronics: DAE4 Sn649; Calibrated: 9/13/2005

Phantom: SAM Main; Type: SAM 4.0; Serial: TP:1197

Measurement SW: DASY4, V4.6 Build 19; Postprocessing SW: SEMCAD, V1.8 Build 159

Laptop Position, LCD Flip, Ch.06, 5.5Mbps, Aux Antenna

Area Scan (7x17x1): Measurement grid: dx=15mm, dy=15mm

Zoom Scan (5x5x7)/Cube 0: Measurement grid: dx=8mm, dy=8mm, dz=5mm

Reference Value = 1.33 V/m

Peak SAR (extrapolated) = 0.032 W/kg

SAR(1 g) = 0.016 mW/g; SAR(10 g) = 0.010 mW/g

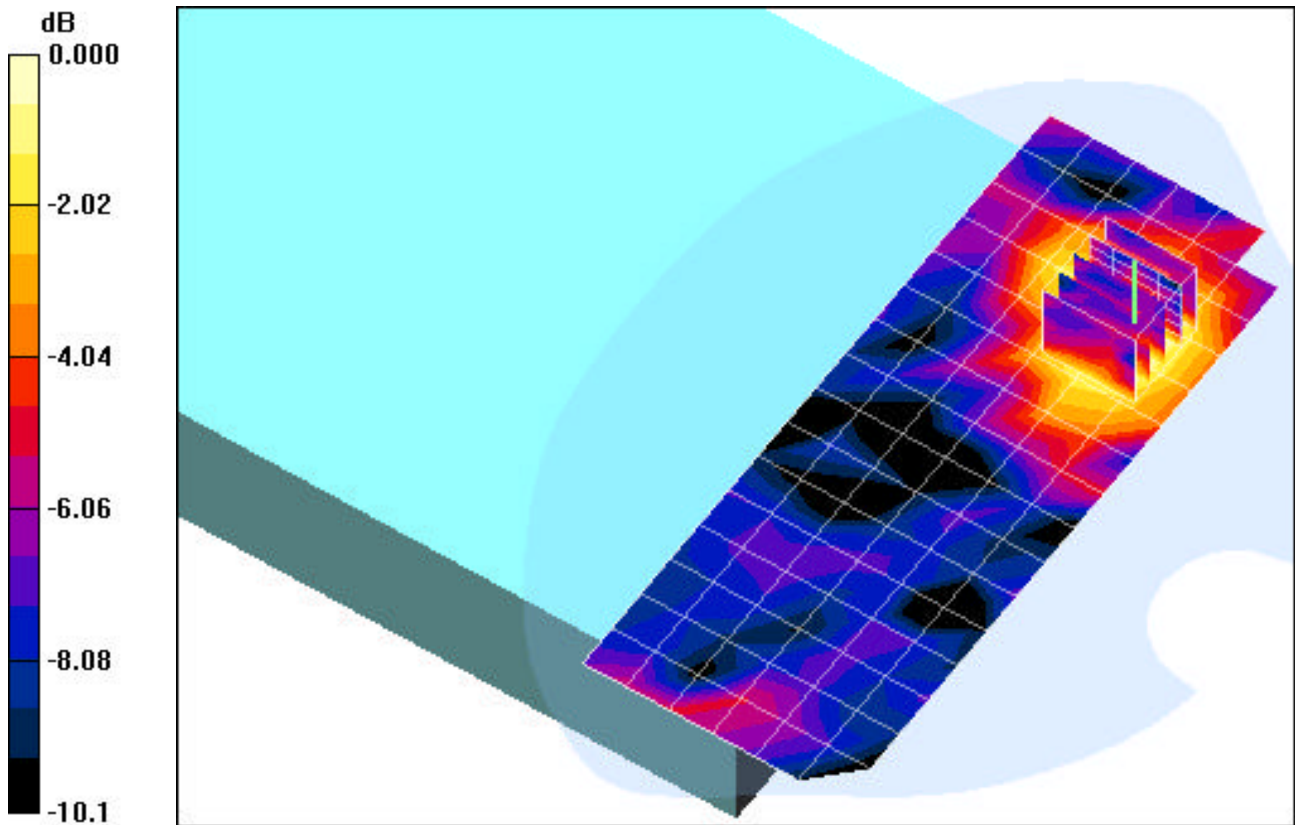

0 dB = 0.019mW/g

PCTEST ENGINEERING LABORATORY, INC.

DUT: CF-18; Type: Notebook PC with WLANa+b+g & Bluetooth & HSDPA; SN: 5KKS50328

Communication System: IEEE 802.11g; Frequency: 2437 MHz; Duty Cycle: 1:1

Medium: 2450 Muscle ($\sigma = 1.93$ mho/m, $\epsilon_r = 54.0$, $\rho = 1000$ kg/m³)

Phantom section: Flat Section; Space: 0.0cm from DUT to Flat Phantom

Test Date: 01-04-2006; Ambient Temp: 23.4°C; Tissue Temp: 21.5°C

Probe: EX3DV4 - SN3561; ConvF(6.3, 6.3, 6.3); Calibrated: 8/24/2005

Sensor-Surface: 3mm (Mechanical Surface Detection)

Electronics: DAE4 Sn649; Calibrated: 9/13/2005

Phantom: SAM Main; Type: SAM 4.0; Serial: TP:1197

Measurement SW: DASY4, V4.6 Build 19; Postprocessing SW: SEMCAD, V1.8 Build 159

Bystander position, LCD Open, Ch.06, 12Mbps, Main Antenna, Bluetooth Off

Area Scan (5x17x1): Measurement grid: dx=15mm, dy=15mm

Zoom Scan (5x5x7)/Cube 0: Measurement grid: dx=8mm, dy=8mm, dz=5mm

Reference Value = 2.05 V/m

Peak SAR (extrapolated) = 0.177 W/kg

SAR(1 g) = 0.089 mW/g; SAR(10 g) = 0.048 mW/g

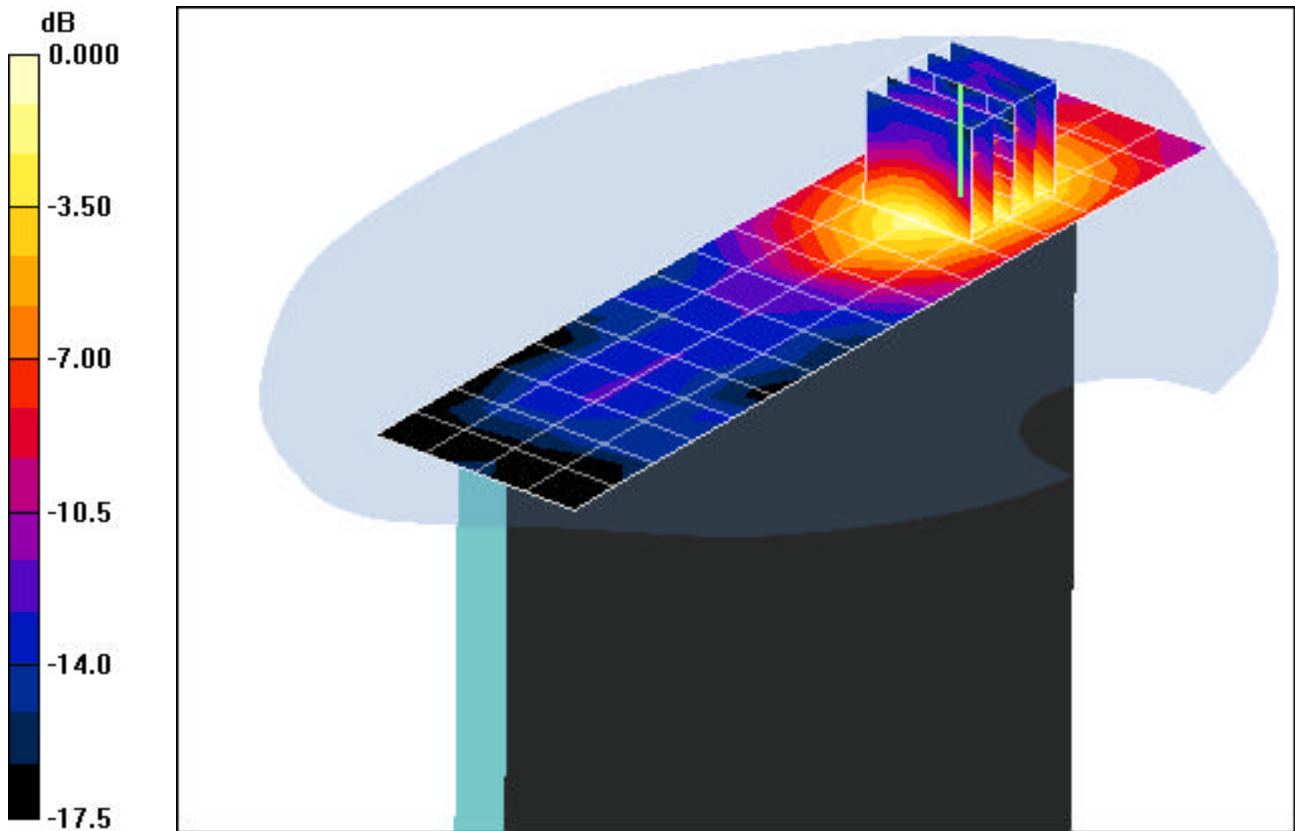

0 dB = 0.112mW/g

PCTEST ENGINEERING LABORATORY, INC.

DUT: CF-18; Type: Notebook PC with WLANa+b+g & Bluetooth & HSDPA; SN: 5KKS50328

Communication System: IEEE 802.11g; Frequency: 2437 MHz; Duty Cycle: 1:1

Medium: 2450 Muscle ($\sigma = 1.93$ mho/m, $\epsilon_r = 54.0$, $\rho = 1000$ kg/m³)

Phantom section: Flat Section; Space: 0.0cm from DUT to Flat Phantom

Test Date: 01-05-2006; Ambient Temp: 23.2°C; Tissue Temp: 21.4°C

Probe: EX3DV4 - SN3561; ConvF(6.3, 6.3, 6.3); Calibrated: 8/24/2005

Sensor-Surface: 3mm (Mechanical Surface Detection)

Electronics: DAE4 Sn649; Calibrated: 9/13/2005

Phantom: SAM Main; Type: SAM 4.0; Serial: TP:1197

Measurement SW: DASY4, V4.6 Build 19; Postprocessing SW: SEMCAD, V1.8 Build 159

Bystander position, LCD Open, Ch.06, 18Mbps, Aux Antenna

Area Scan (5x17x1): Measurement grid: dx=15mm, dy=15mm

Zoom Scan (5x5x7)/Cube 0: Measurement grid: dx=8mm, dy=8mm, dz=5mm

Reference Value = 1.46 V/m

Peak SAR (extrapolated) = 0.223 W/kg

SAR(1 g) = 0.115 mW/g; SAR(10 g) = 0.062 mW/g

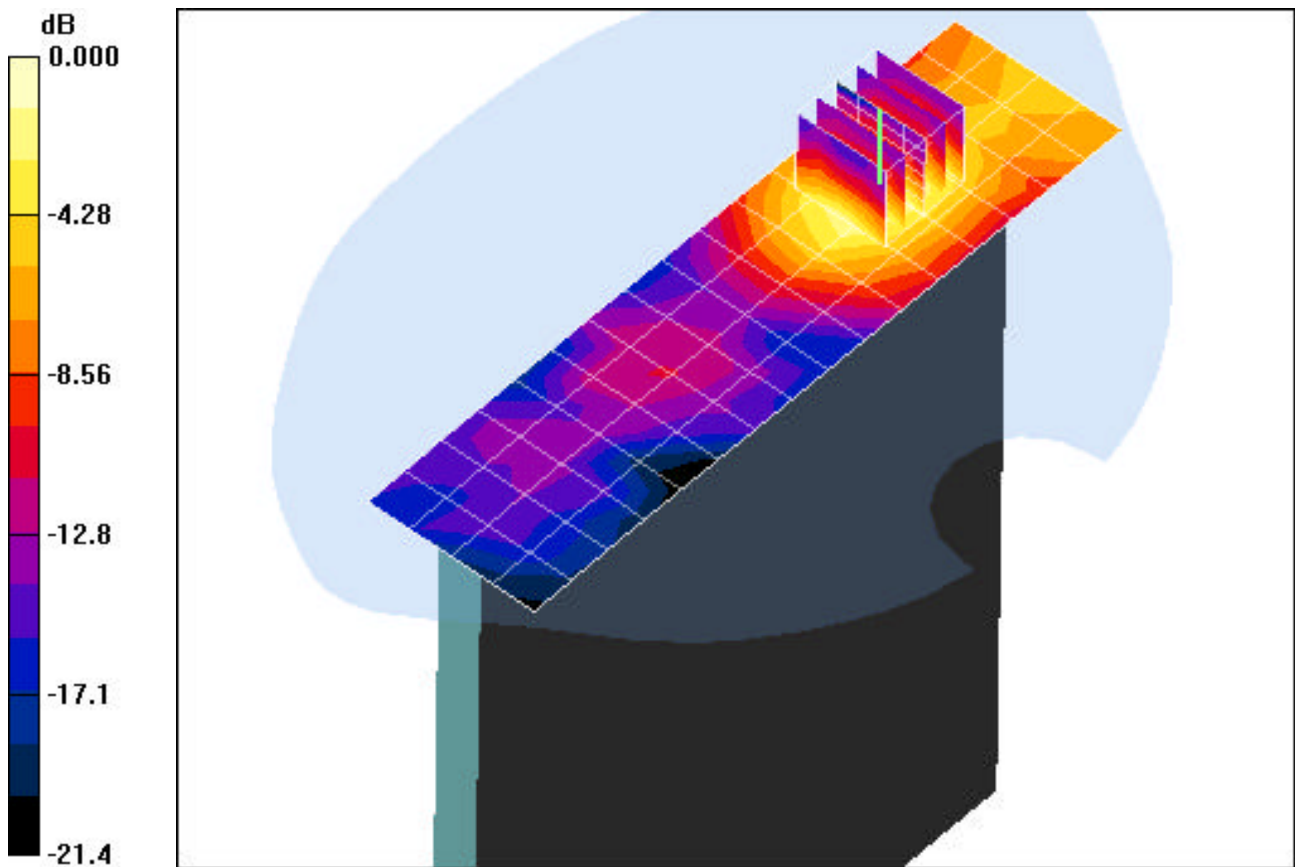

0 dB = 0.144mW/g

PCTEST ENGINEERING LABORATORY, INC.

DUT: CF-18; Type: Notebook PC with WLANa+b+g & Bluetooth & HSDPA; SN: 5KKS50328

Communication System: IEEE 802.11g; Frequency: 2437 MHz; Duty Cycle: 1:1

Medium: 2450 Muscle ($\sigma = 1.93$ mho/m, $\epsilon_r = 54.0$, $\rho = 1000$ kg/m³)

Phantom section: Flat Section; Space: 0.0cm from DUT to Flat Phantom

Test Date: 01-05-2006; Ambient Temp: 23.2°C; Tissue Temp: 21.4°C

Probe: EX3DV4 - SN3561; ConvF(6.3, 6.3, 6.3); Calibrated: 8/24/2005

Sensor-Surface: 3mm (Mechanical Surface Detection)

Electronics: DAE4 Sn649; Calibrated: DAE not calibrated

Phantom: SAM Main; Type: SAM 4.0; Serial: TP:1197

Measurement SW: DASY4, V4.6 Build 19; Postprocessing SW: SEMCAD, V1.8 Build 159

Tablet position, LCD Flip, Ch.06, 12Mbps, Main antenna, Bluetooth Off

Area Scan (7x17x1): Measurement grid: dx=15mm, dy=15mm

Zoom Scan (5x5x7)/Cube 0: Measurement grid: dx=8mm, dy=8mm, dz=5mm

Reference Value = 1.93 V/m

Peak SAR (extrapolated) = 0.140 W/kg

SAR(1 g) = 0.075 mW/g; SAR(10 g) = 0.041 mW/g

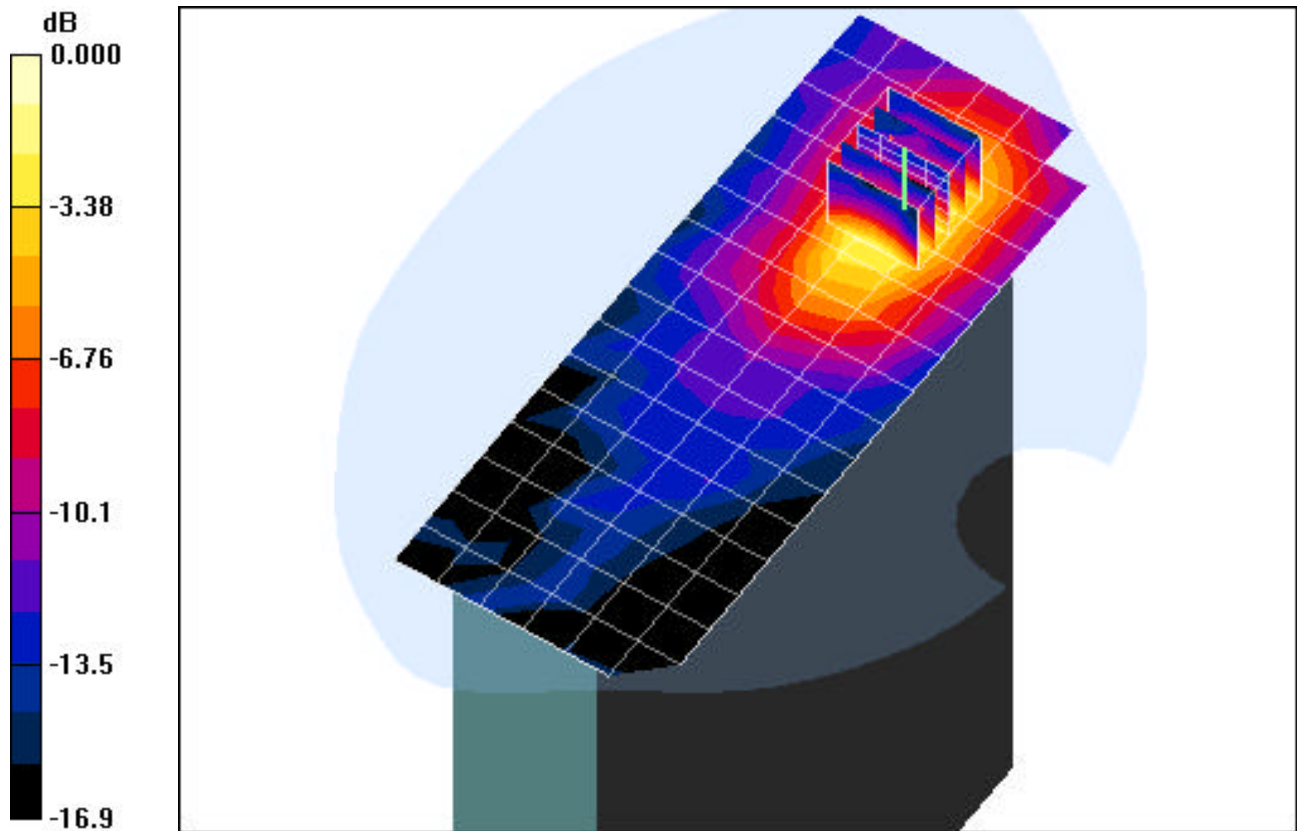

0 dB = 0.095mW/g

PCTEST ENGINEERING LABORATORY, INC.

DUT: CF-18 ; Type: Notebook PC with WLANa+b+g & Bluetooth & HSDPA; SN: 5KKS50328

Communication System: IEEE 802.11g; Frequency: 2437 MHz;Duty Cycle: 1:1

Medium: 2450 Muscle ($\sigma = 1.93$ mho/m, $\epsilon_r = 54.0$, $\rho = 1000$ kg/m³)

Phantom section: Flat Section; Space: 0.0cm from DUT to Flat Phantom

Test Date: 01-05-2006; Ambient Temp: 23.2°C; Tissue Temp: 21.4°C

Probe: EX3DV4 - SN3561; ConvF(6.3, 6.3, 6.3); Calibrated: 8/24/2005

Sensor-Surface: 3mm (Mechanical Surface Detection)

Electronics: DAE4 Sn649; Calibrated: DAE not calibrated

Phantom: SAM Main; Type: SAM 4.0; Serial: TP:1197

Measurement SW: DASY4, V4.6 Build 19; Postprocessing SW: SEMCAD, V1.8 Build 159

Tablet position, LCD Flip, Right side, Ch.06, 18Mbps, Aux Antenna

Area Scan (7x17x1): Measurement grid: dx=15mm, dy=15mm

Zoom Scan (5x5x7)/Cube 0: Measurement grid: dx=8mm, dy=8mm, dz=5mm

Reference Value = 2.23 V/m

Peak SAR (extrapolated) = 0.154 W/kg

SAR(1 g) = 0.083 mW/g; SAR(10 g) = 0.046 mW/g

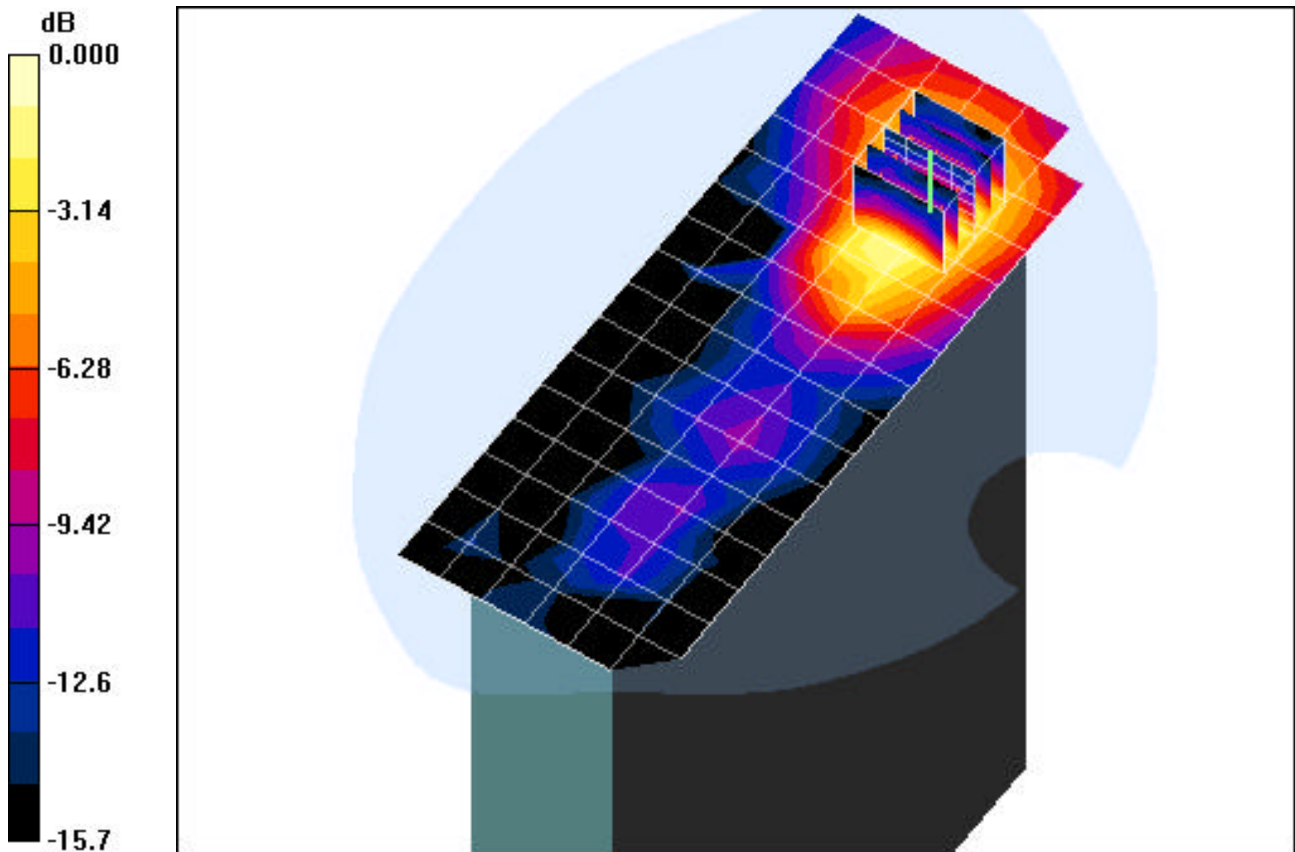

0 dB = 0.104mW/g

PCTEST ENGINEERING LABORATORY, INC.

DUT: CF-18; Type: Notebook PC with WLANa+b+g & Bluetooth & HSDPA; SN: 5KKS50328

Communication System: IEEE 802.11g; Frequency: 2437 MHz; Duty Cycle: 1:1

Medium: 2450 Muscle ($\sigma = 1.93$ mho/m, $\epsilon_r = 54.0$, $\rho = 1000$ kg/m³)

Phantom section: Flat Section; Space: 0.0cm from DUT to Flat Phantom

Test Date: 01-05-2006; Ambient Temp: 23.2°C; Tissue Temp: 21.4°C

Probe: EX3DV4 - SN3561; ConvF(6.3, 6.3, 6.3); Calibrated: 8/24/2005

Sensor-Surface: 3mm (Mechanical Surface Detection)

Electronics: DAE4 Sn649; Calibrated: DAE not calibrated

Phantom: SAM Main; Type: SAM 4.0; Serial: TP:1197

Measurement SW: DASY4, V4.6 Build 19; Postprocessing SW: SEMCAD, V1.8 Build 159

Laptop Position, LCD Flip, Ch.06, 12Mbps, Main antenna, Bluetooth Off

Area Scan (7x17x1): Measurement grid: dx=15mm, dy=15mm

Zoom Scan (5x5x7)/Cube 0: Measurement grid: dx=8mm, dy=8mm, dz=5mm

Reference Value = 1.18 V/m

Peak SAR (extrapolated) = 0.016 W/kg

SAR(1 g) = 0.011 mW/g; SAR(10 g) = 0.00691 mW/g

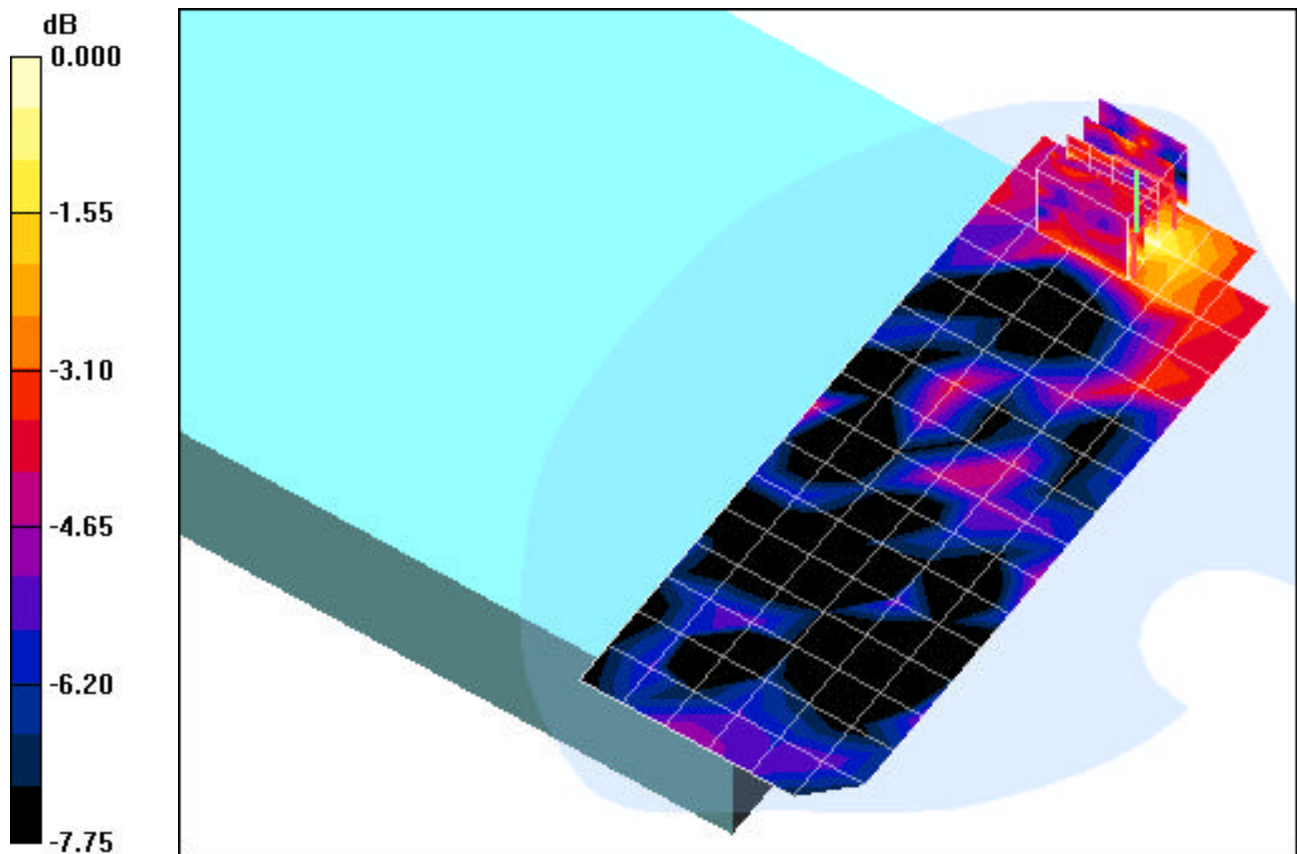

0 dB = 0.012mW/g

PCTEST ENGINEERING LABORATORY, INC.

DUT: CF-18; Type: Notebook PC with WLANa+b+g & Bluetooth & HSDPA; SN: 5KKS50328

Communication System: IEEE 802.11b; Frequency: 2437 MHz; Duty Cycle: 1:1

Medium: 2450 Muscle ($\sigma = 1.93$ mho/m, $\epsilon_r = 54.0$, $\rho = 1000$ kg/m³)

Phantom section: Flat Section; Space: 0.0cm from DUT to Flat Phantom

Test Date: 01-05-2006; Ambient Temp: 23.2°C; Tissue Temp: 21.4°C

Probe: EX3DV4 - SN3561; ConvF(6.3, 6.3, 6.3); Calibrated: 8/24/2005

Sensor-Surface: 3mm (Mechanical Surface Detection)

Electronics: DAE4 Sn649; Calibrated: DAE not calibrated

Phantom: SAM Main; Type: SAM 4.0; Serial: TP:1197

Measurement SW: DASY4, V4.6 Build 19; Postprocessing SW: SEMCAD, V1.8 Build 159

Laptop Position, LCD Flip, Ch.06, 5.5Mbps, Aux antenna

Area Scan (7x17x1): Measurement grid: dx=15mm, dy=15mm

Zoom Scan (5x5x7)/Cube 0: Measurement grid: dx=8mm, dy=8mm, dz=5mm

Reference Value = 0.585 V/m

Peak SAR (extrapolated) = 0.013 W/kg

SAR(1 g) = 0.00443 mW/g; SAR(10 g) = 0.00308 mW/g

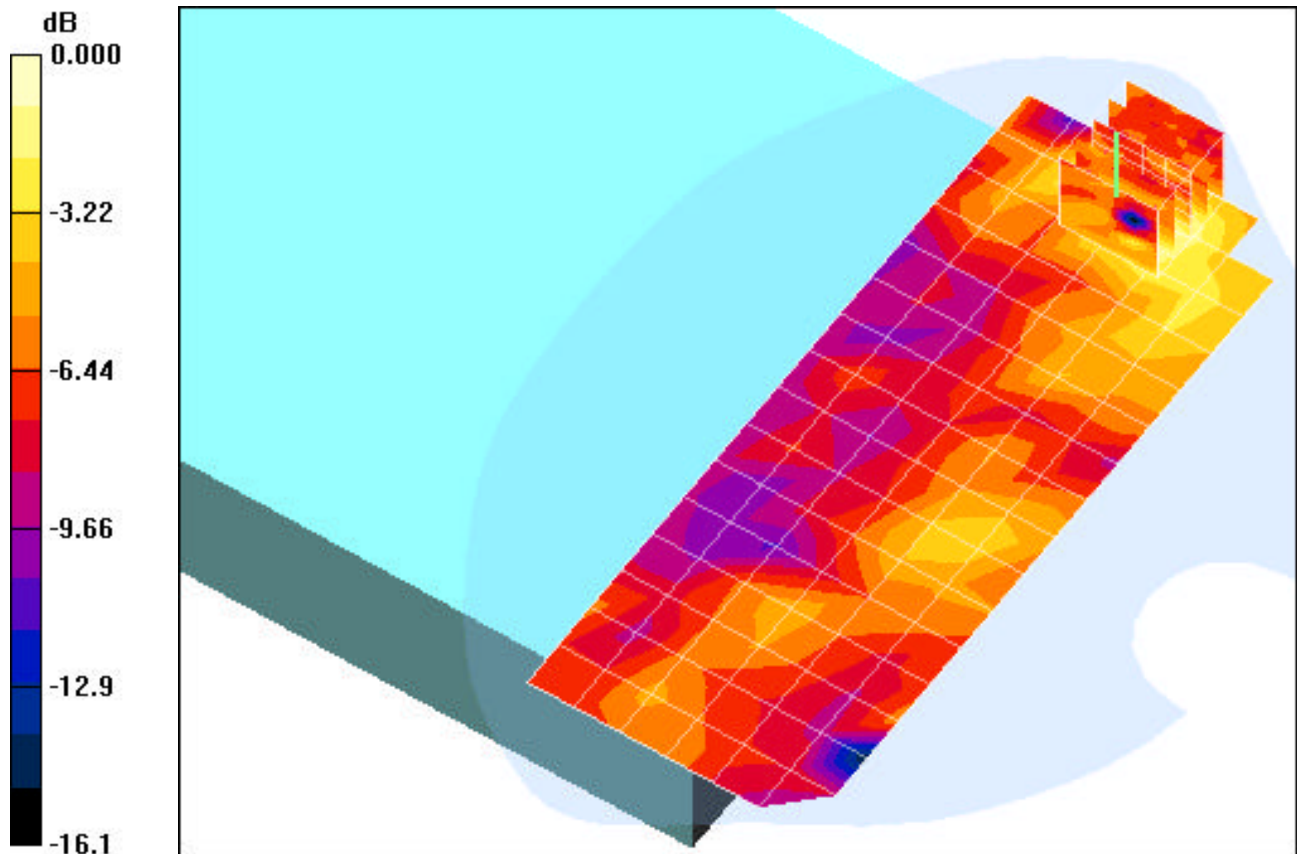

0 dB = 0.021mW/g

PCTEST ENGINEERING LABORATORY, INC.

DUT: CF-18; Type: Notebook PC with WLANa+b+g & Bluetooth & HSDPA; SN: 5KKS50328

Communication System: Bluetooth; Frequency: 2441 MHz; Duty Cycle: 1:1

Medium: 2450 Muscle ($\sigma = 1.93$ mho/m, $\epsilon_r = 54.0$, $\rho = 1000$ kg/m³)

Phantom section: Flat Section

Test Date: 01-05-2006; Ambient Temp: 23.2°C; Tissue Temp: 21.4°C

Probe: EX3DV4 - SN3561; ConvF(6.3, 6.3, 6.3); Calibrated: 8/24/2005

Sensor-Surface: 3mm (Mechanical Surface Detection)

Electronics: DAE4 Sn649; Calibrated: 9/13/2005

Phantom: SAM Main; Type: SAM 4.0; Serial: TP:1197

Measurement SW: DASY4, V4.6 Build 19; Postprocessing SW: SEMCAD, V1.8 Build 159

Bystander position, LCD Open, Ch.39

Area Scan (5x17x1): Measurement grid: dx=15mm, dy=15mm

Zoom Scan (5x5x7)/Cube 0: Measurement grid: dx=8mm, dy=8mm, dz=5mm

Reference Value = 5.18 V/m

Peak SAR (extrapolated) = 0.116 W/kg

SAR(1 g) = 0.061 mW/g; SAR(10 g) = 0.033 mW/g

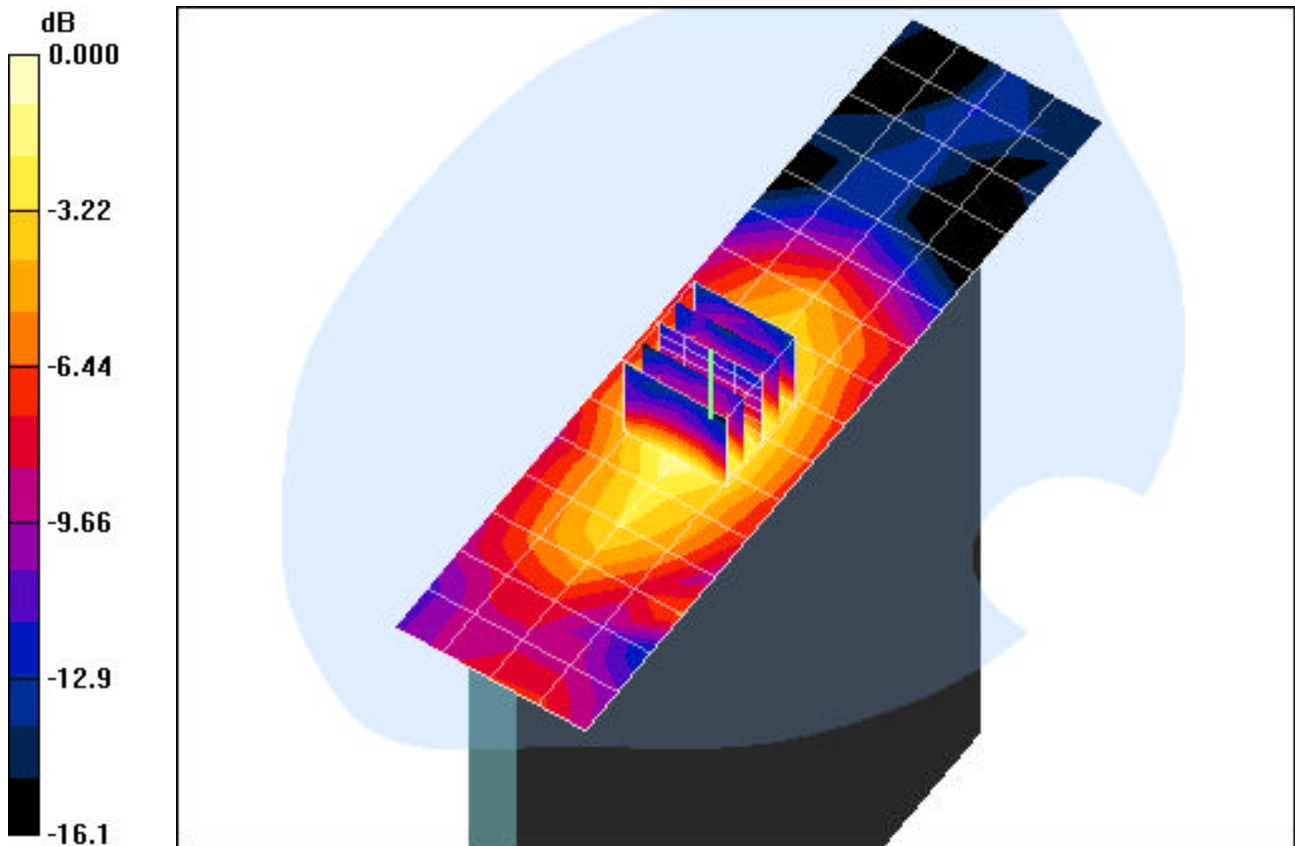

0 dB = 0.076mW/g

PCTEST ENGINEERING LABORATORY, INC.

DUT: CF-18; Type: Notebook PC with WLANa+b+g & Bluetooth & HSDPA; SN: 5KKS50328

Communication System: Bluetooth; Frequency: 2441 MHz; Duty Cycle: 1:1

Medium: 2450 Muscle ($\sigma = 1.93$ mho/m, $\epsilon_r = 54.0$, $\rho = 1000$ kg/m³)

Phantom section: Flat Section; Space: 0.0cm from DUT to Flat Phantom

Test Date: 01-05-2006; Ambient Temp: 23.2°C; Tissue Temp: 21.4°C

Probe: EX3DV4 - SN3561; ConvF(6.3, 6.3, 6.3); Calibrated: 8/24/2005

Sensor-Surface: 3mm (Mechanical Surface Detection)

Electronics: DAE4 Sn649; Calibrated: 9/13/2005

Phantom: SAM Main; Type: SAM 4.0; Serial: TP:1197

Measurement SW: DASY4, V4.6 Build 19; Postprocessing SW: SEMCAD, V1.8 Build 159

Tablet position, LCD Flip, Left side, Ch.39

Area Scan (7x17x1): Measurement grid: dx=15mm, dy=15mm

Zoom Scan (5x5x7)/Cube 0: Measurement grid: dx=8mm, dy=8mm, dz=5mm

Reference Value = 4.52 V/m

Peak SAR (extrapolated) = 0.103 W/kg

SAR(1 g) = 0.055 mW/g; SAR(10 g) = 0.031 mW/g

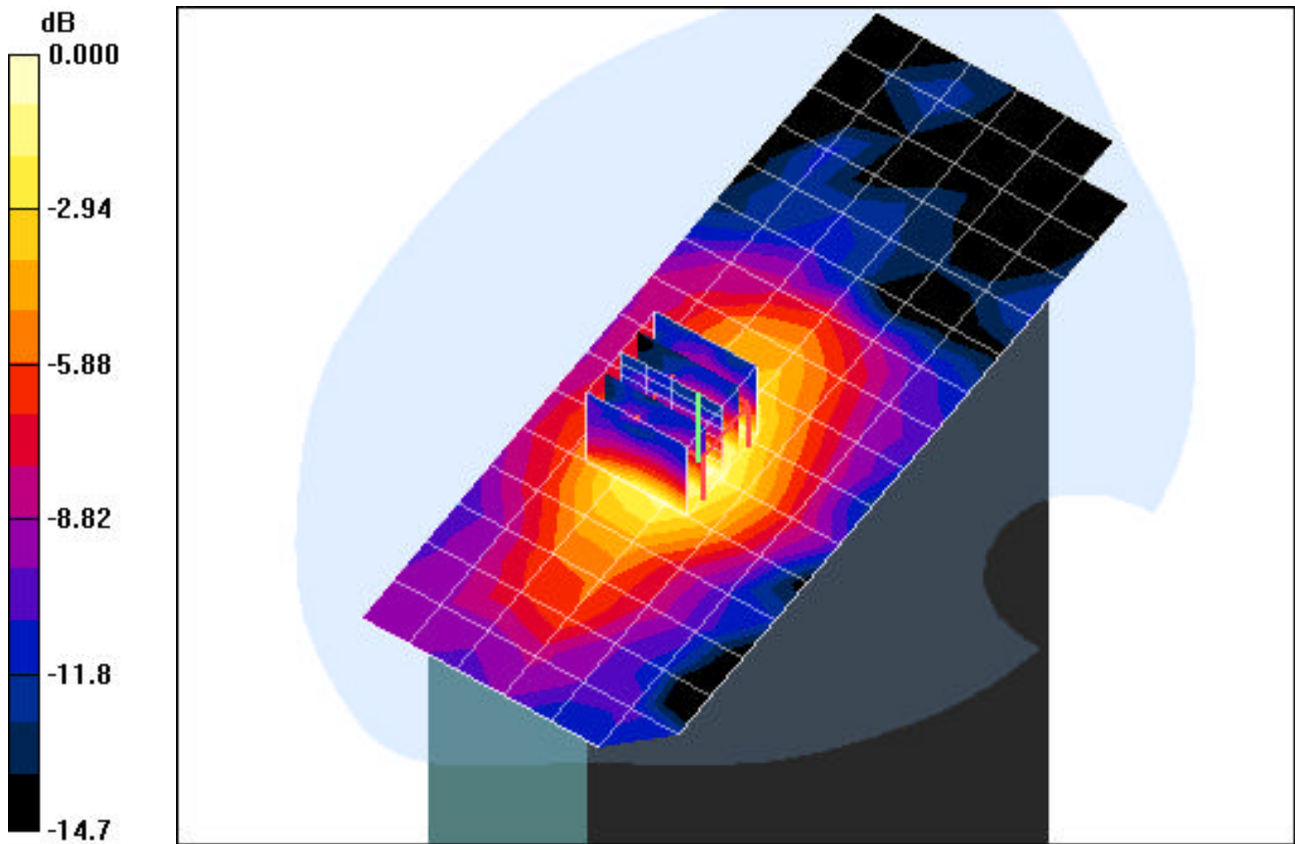

0 dB = 0.065mW/g

PCTEST ENGINEERING LABORATORY, INC.

DUT: CF-18; Type: Notebook PC with WLANa+b+g & Bluetooth & HSDPA; SN: 5KKS50328

Communication System: Bluetooth; Frequency: 2441 MHz; Duty Cycle: 1:1

Medium: 2450 Muscle ($\sigma = 1.93$ mho/m, $\epsilon_r = 54.0$, $\rho = 1000$ kg/m³)

Phantom section: Flat Section; Space: 0.0cm from DUT to Flat Phantom

Test Date: 01-05-2006; Ambient Temp: 23.2°C; Tissue Temp: 21.4°C

Probe: EX3DV4 - SN3561; ConvF(6.3, 6.3, 6.3); Calibrated: 8/24/2005

Sensor-Surface: 3mm (Mechanical Surface Detection)

Electronics: DAE4 Sn649; Calibrated: 9/13/2005

Phantom: SAM Main; Type: SAM 4.0; Serial: TP:1197

Measurement SW: DASY4, V4.6 Build 19; Postprocessing SW: SEMCAD, V1.8 Build 159

Laptop position, LCD Flip, Ch.39

Area Scan (7x17x1): Measurement grid: dx=15mm, dy=15mm

Zoom Scan (5x5x7)/Cube 0: Measurement grid: dx=8mm, dy=8mm, dz=5mm

Reference Value = 1.19 V/m

Peak SAR (extrapolated) = 0.027 W/kg

SAR(1 g) = 0.0051 mW/g; SAR(10 g) = 0.0037 mW/g

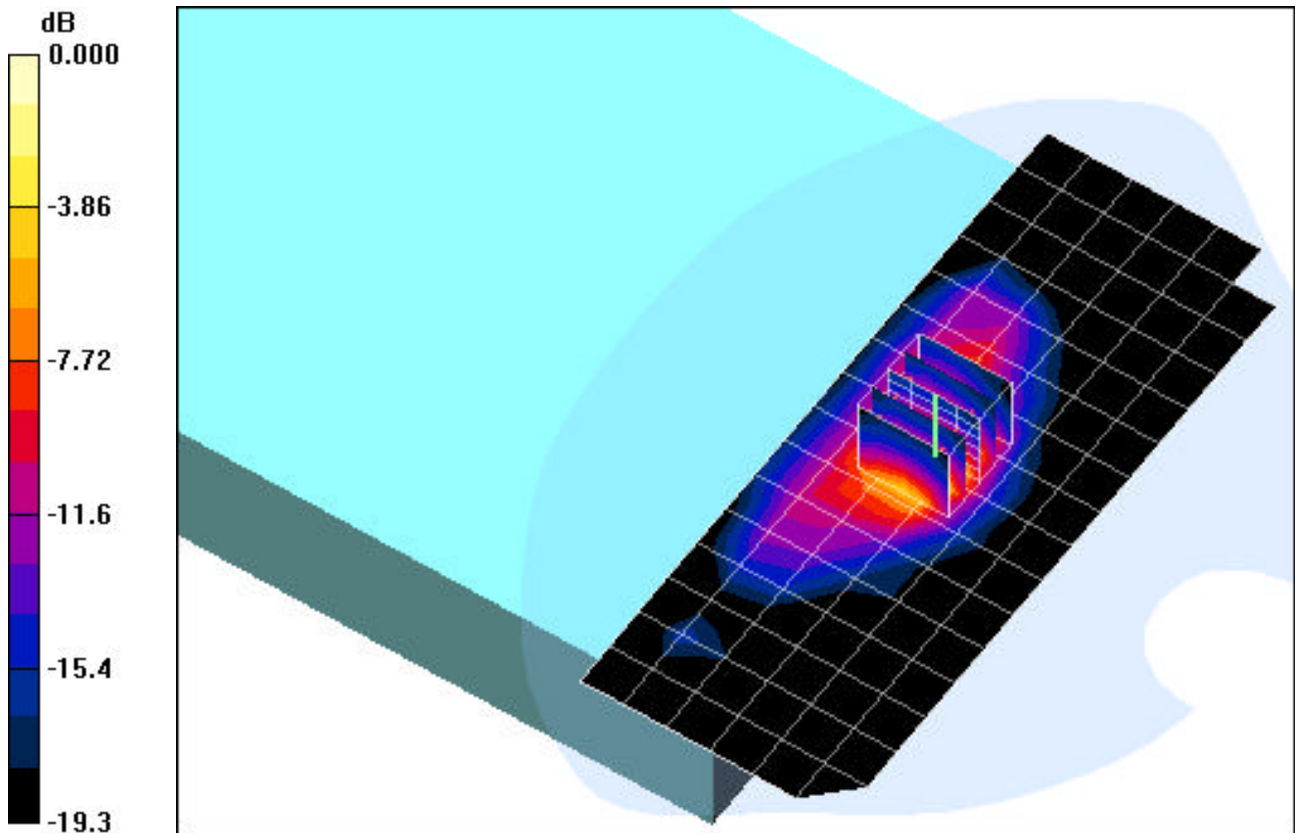

0 dB = 0.024mW/g

PCTEST ENGINEERING LABORATORY, INC.

DUT: CF -18; Type: Notebook PC with WLANa+b+g & Bluetooth & HSDPA; SN: 5KKS50328

Communication System: IEEE 802.11a; Frequency: 5260 MHz; Duty Cycle: 1:1

Medium: 5300 Muscle ($\sigma = 5.48$ mho/m, $\epsilon_r = 48.33$, $\rho = 1000$ kg/m³)

Phantom section: Flat Section; Space: 0.0cm from DUT to Flat Phantom

Test Date: 01-11-2006; Ambient Temp: 23.5°C; Tissue Temp: 21.5°C

Probe: EX3DV4 - SN3561; ConvF(4.1, 4.1, 4.1); Calibrated: 8/24/2005

Sensor-Surface: 3mm (Mechanical Surface Detection)

Electronics: DAE4 Sn649; Calibrated: 9/13/2005

Phantom: SAM Main; Type: SAM 4.0; Serial: TP:1197

Measurement SW: DASY4, V4.6 Build 19; Postprocessing SW: SEMCAD, V1.8 Build 159

Bystander position, LCD Open, Ch.52, 18Mbps, Main Antenna, Bluetooth Off

Area Scan (5x17x1): Measurement grid: dx=15mm, dy=15mm

Zoom Scan (5x5x7)/Cube 0: Measurement grid: dx=8mm, dy=8mm, dz=5mm

Reference Value = 4.85 V/m

Peak SAR (extrapolated) = 1.09 W/kg

SAR(1 g) = 0.334 mW/g; SAR(10 g) = 0.118 mW/g

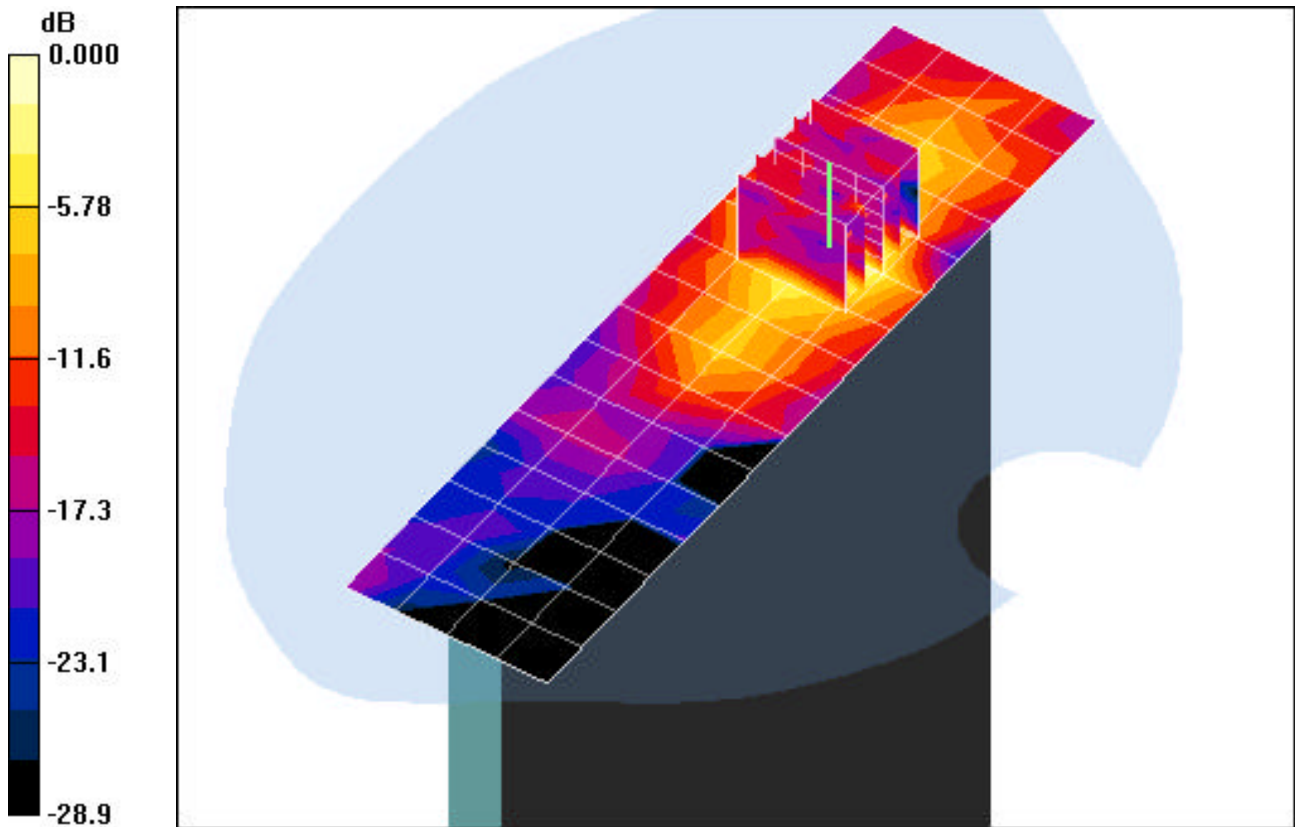

0 dB = 0.469mW/g

PCTEST ENGINEERING LABORATORY, INC.

DUT: CF-18; Type: Notebook PC with WLANa+b+g & Bluetooth & HSDPA; SN: 5KKS50328

Communication System: IEEE 802.11a; Frequency: 5260 MHz; Duty Cycle: 1:1

Medium: 5300 Muscle ($\sigma = 5.48$ mho/m, $\epsilon_r = 48.33$, $\rho = 1000$ kg/m³)

Phantom section: Flat Section; Space: 0.0cm from DUT to Flat Phantom

Test Date: 01-11-2006; Ambient Temp: 23.5°C; Tissue Temp: 21.5°C

Probe: EX3DV4 - SN3561; ConvF(4.1, 4.1, 4.1); Calibrated: 8/24/2005

Sensor-Surface: 3mm (Mechanical Surface Detection)

Electronics: DAE4 Sn649; Calibrated: 9/13/2005

Phantom: SAM Main; Type: SAM 4.0; Serial: TP:1197

Measurement SW: DASY4, V4.6 Build 19; Postprocessing SW: SEMCAD, V1.8 Build 159

Bystander position, LCD Open, Ch.52, 18Mbps, Aux Antenna

Area Scan (5x17x1): Measurement grid: dx=15mm, dy=15mm

Zoom Scan (5x5x7)/Cube 0: Measurement grid: dx=8mm, dy=8mm, dz=5mm

Reference Value = 3.70 V/m

Peak SAR (extrapolated) = 3.92 W/kg

SAR(1 g) = 0.841 mW/g; SAR(10 g) = 0.306 mW/g

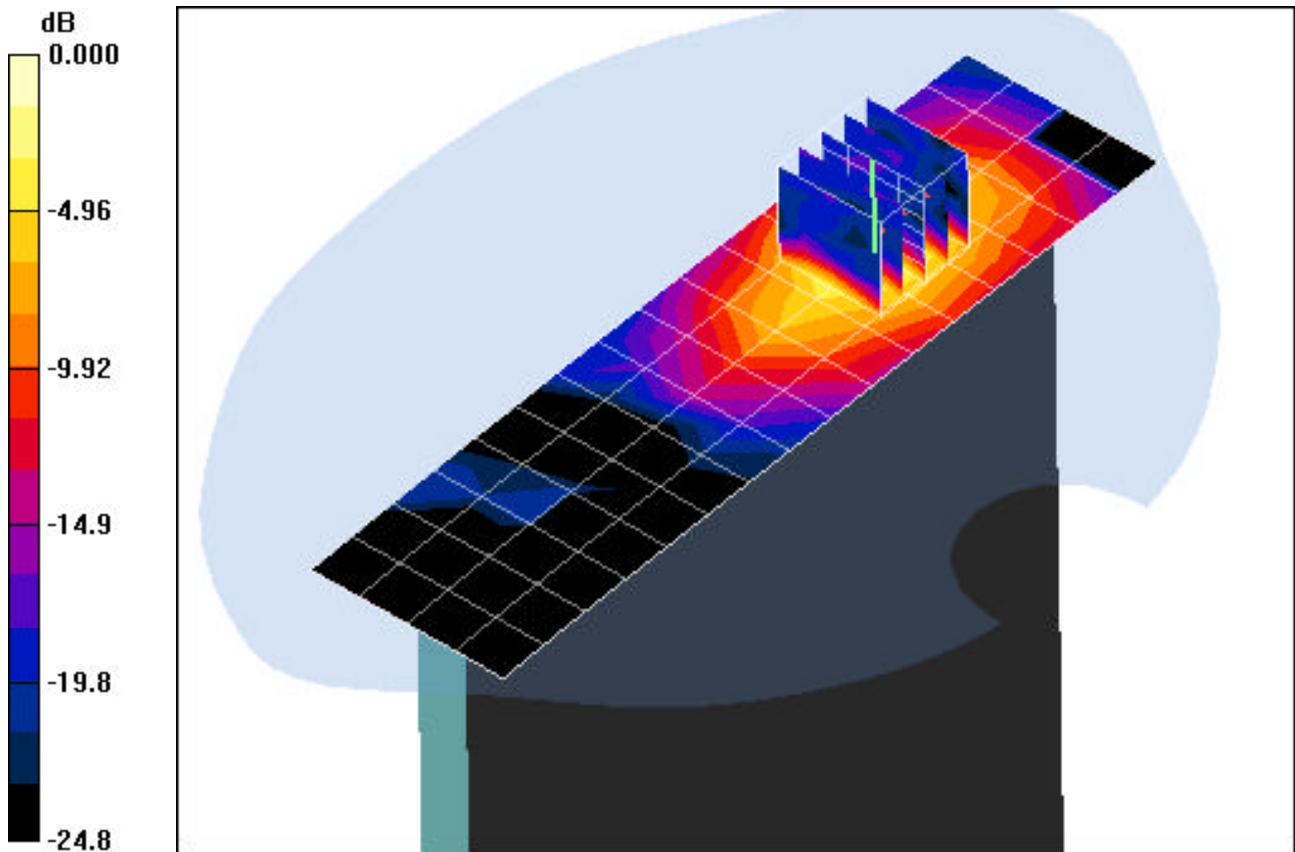

0 dB = 1.07mW/g

PCTEST ENGINEERING LABORATORY, INC.

DUT: CF -18; Type: Notebook PC with WLANa+b+g & Bluetooth & HSDPA; SN: 5KKS50328

Communication System: IEEE 802.11a; Frequency: 5260 MHz; Duty Cycle: 1:1

Medium: 5300 Muscle ($\sigma = 5.48 \text{ mho/m}$, $\epsilon_r = 48.33$, $\rho = 1000 \text{ kg/m}^3$)

Phantom section: Flat Section; Space: 0.0cm from DUT to Flat Phantom

Test Date: 01-11-2006; Ambient Temp: 23.5°C; Tissue Temp: 21.5°C

Probe: EX3DV4 - SN3561; ConvF(4.1, 4.1, 4.1); Calibrated: 8/24/2005

Sensor-Surface: 3mm (Mechanical Surface Detection)

Electronics: DAE4 Sn649; Calibrated: 9/13/2005

Phantom: SAM Main; Type: SAM 4.0; Serial: TP:1197

Measurement SW: DASY4, V4.6 Build 19; Postprocessing SW: SEMCAD, V1.8 Build 159

Tablet position, LCD Open, Ch.52, 18Mbps, Main Antenna, Bluetooth Off

Area Scan (7x17x1): Measurement grid: dx=15mm, dy=15mm

Zoom Scan (5x5x7)/Cube 0: Measurement grid: dx=8mm, dy=8mm, dz=5mm

Reference Value = 4.31 V/m

Peak SAR (extrapolated) = 1.72 W/kg

SAR(1 g) = 0.359 mW/g; SAR(10 g) = 0.133 mW/g

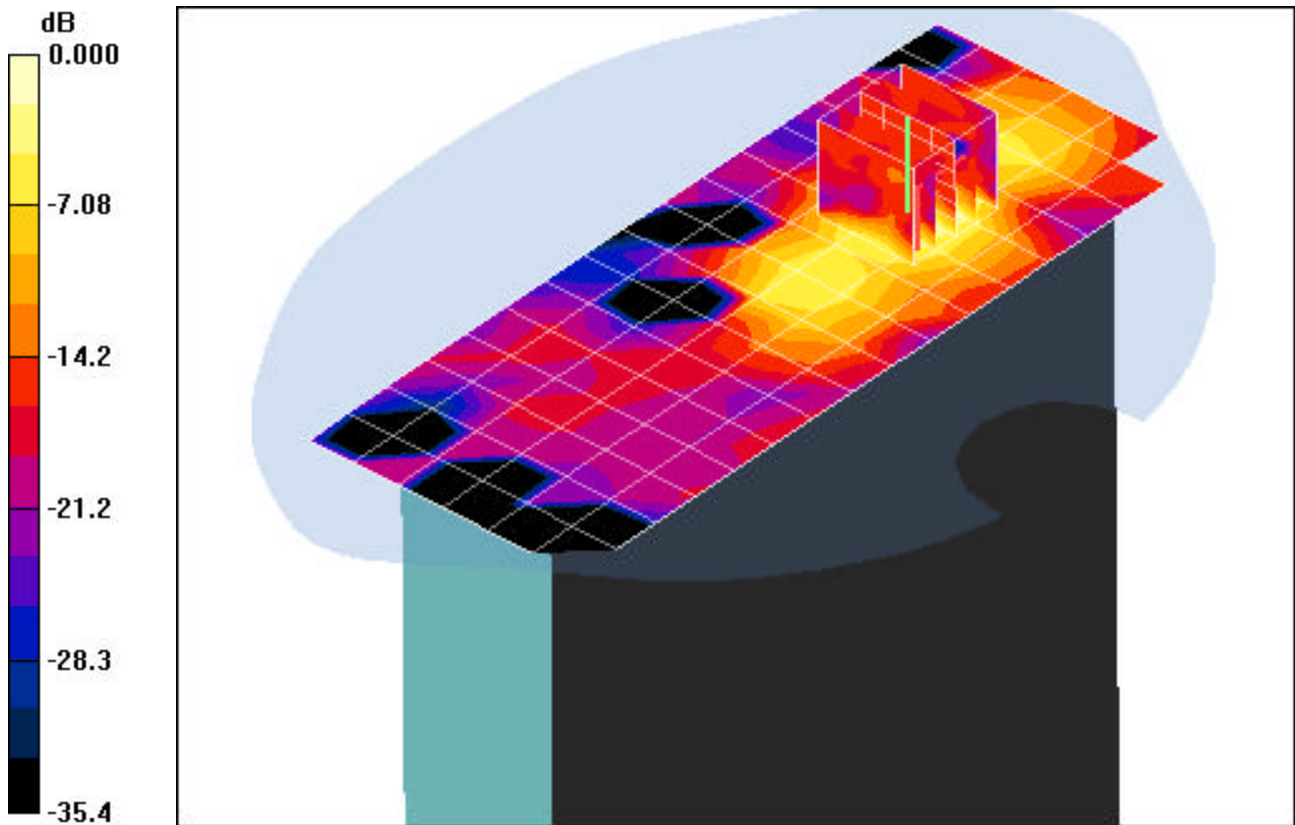

0 dB = 0.502mW/g

PCTEST ENGINEERING LABORATORY, INC.

DUT: CF -18; Type: Notebook PC with WLANa+b+g & Bluetooth & HSDPA; SN: 5KKS50328

Communication System: IEEE 802.11a; Frequency: 5260 MHz; Duty Cycle: 1:1

Medium: 5300 Muscle ($\sigma = 5.48$ mho/m, $\epsilon_r = 48.33$, $\rho = 1000$ kg/m³)

Phantom section: Flat Section; Space: 0.0cm from DUT to Flat Phantom

Test Date: 01-11-2006; Ambient Temp: 23.5°C; Tissue Temp: 21.5°C

Probe: EX3DV4 - SN3561; ConvF(4.1, 4.1, 4.1); Calibrated: 8/24/2005

Sensor-Surface: 3mm (Mechanical Surface Detection)

Electronics: DAE4 Sn649; Calibrated: 9/13/2005

Phantom: SAM Main; Type: SAM 4.0; Serial: TP:1197

Measurement SW: DASY4, V4.6 Build 19; Postprocessing SW: SEMCAD, V1.8 Build 159

Tablet position, LCD Flip, Ch.52, 18Mbps, Aux Antenna

Area Scan (7x17x1): Measurement grid: dx=15mm, dy=15mm

Zoom Scan (5x5x7)/Cube 0: Measurement grid: dx=8mm, dy=8mm, dz=5mm

Reference Value = 2.80 V/m

Peak SAR (extrapolated) = 2.21 W/kg

SAR(1 g) = 0.674 mW/g; SAR(10 g) = 0.249 mW/g

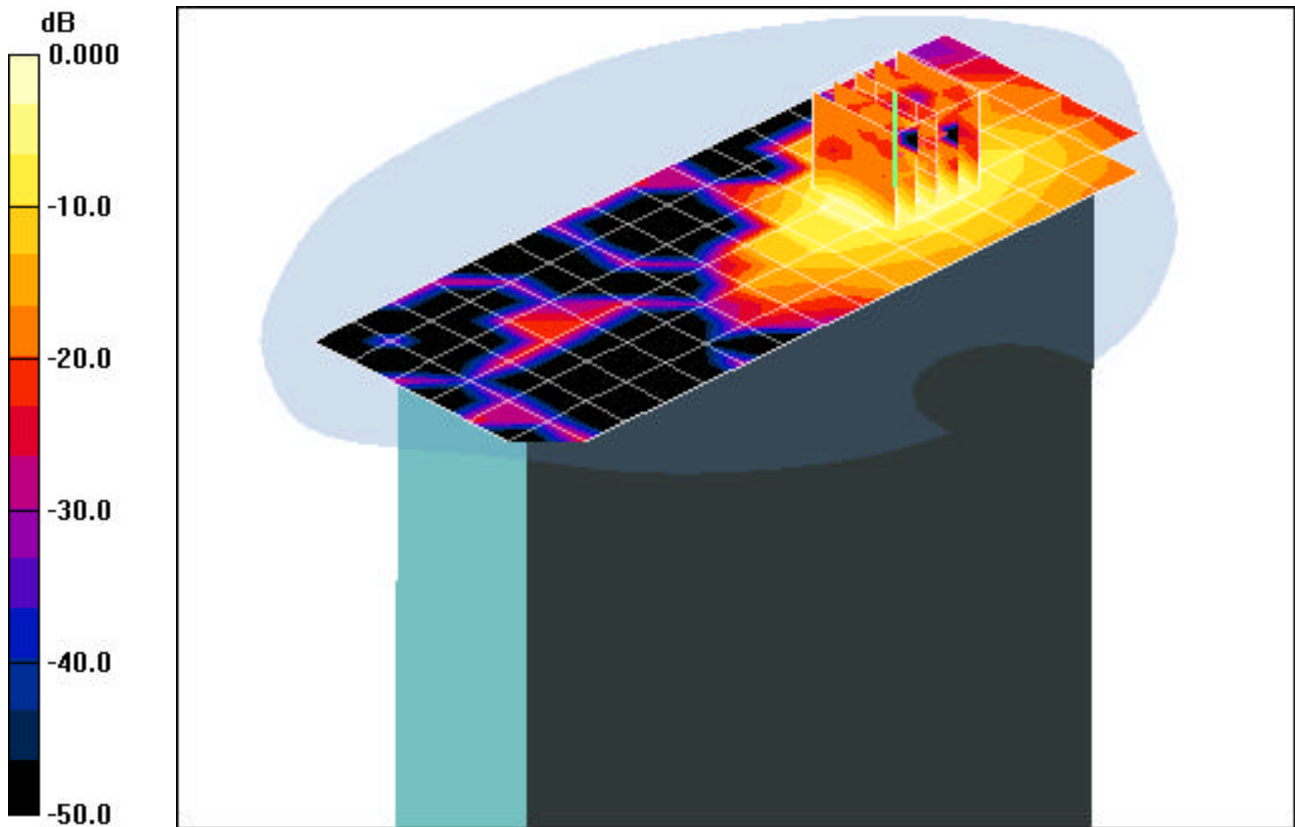

0 dB = 1.07mW/g

PCTEST ENGINEERING LABORATORY, INC.

DUT: CF -18; Type: Notebook PC with WLANa+b+g & Bluetooth & HSDPA; SN: 5KKS50328

Communication System: IEEE 802.11a; Frequency: 5260 MHz; Duty Cycle: 1:1

Medium: 5300 Muscle ($\sigma = 5.48$ mho/m, $\epsilon_r = 48.33$, $\rho = 1000$ kg/m³)

Phantom section: Flat Section; Space: 0.0cm from DUT to Flat Phantom

Test Date: 01-11-2006; Ambient Temp: 23.5°C; Tissue Temp: 21.5°C

Probe: EX3DV4 - SN3561; ConvF(4.1, 4.1, 4.1); Calibrated: 8/24/2005

Sensor-Surface: 3mm (Mechanical Surface Detection)

Electronics: DAE4 Sn649; Calibrated: 9/13/2005

Phantom: SAM Main; Type: SAM 4.0; Serial: TP:1197

Measurement SW: DASY4, V4.6 Build 19; Postprocessing SW: SEMCAD, V1.8 Build 159

Laptop position, LCD Open, Ch.52, 18Mbps, Main Antenna, Bluetooth Off

Area Scan (7x18x1): Measurement grid: dx=15mm, dy=15mm

Zoom Scan (5x5x7)/Cube 0: Measurement grid: dx=8mm, dy=8mm, dz=5mm

Reference Value = 2.18 V/m

Peak SAR (extrapolated) = 0.132 W/kg

SAR(1 g) = 0.027 mW/g; SAR(10 g) = 0.019 mW/g

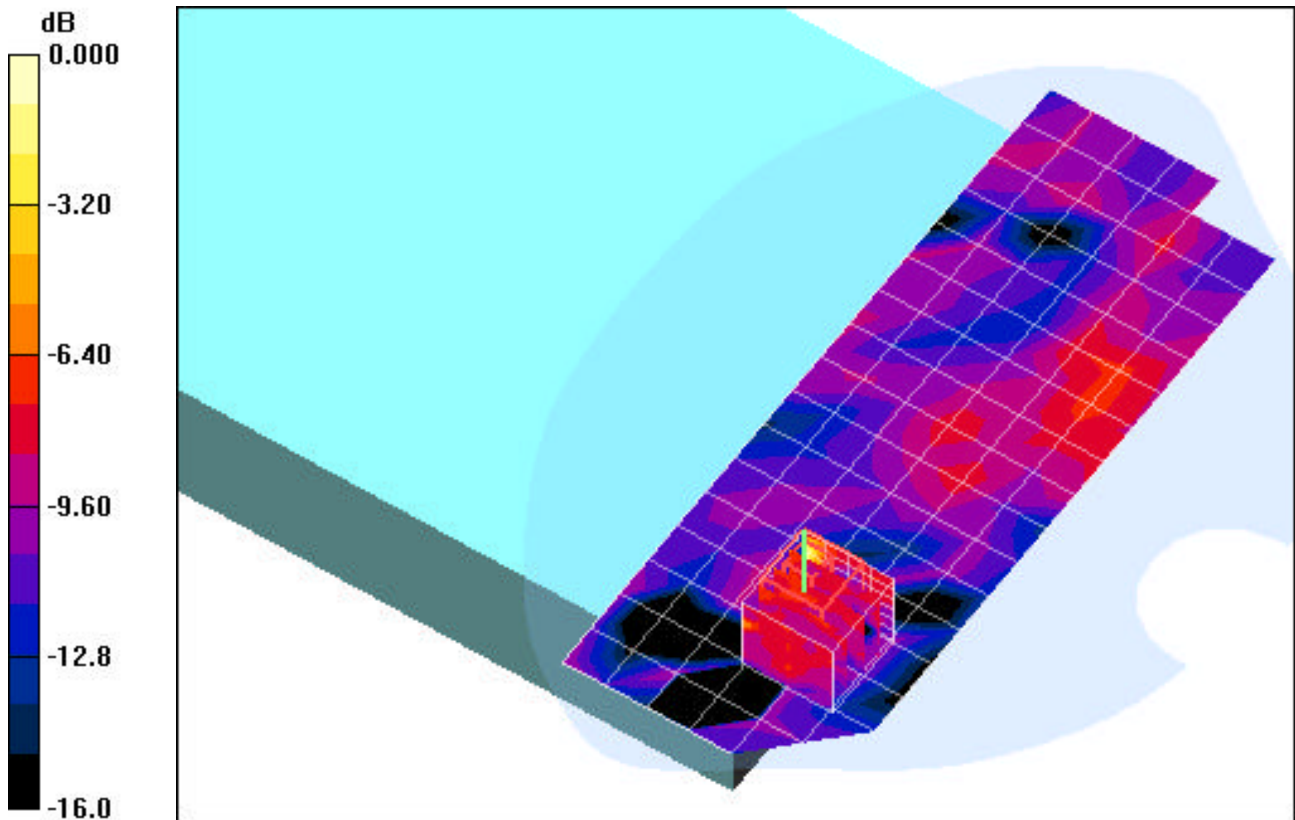

0 dB = 0.126mW/g

PCTEST ENGINEERING LABORATORY, INC.

DUT: CF-18; Type: Notebook PC with WLANa+b+g & Bluetooth & HSDPA; SN: 5KKS50328

Communication System: IEEE 802.11a; Frequency: 5260 MHz; Duty Cycle: 1:1

Medium: 5300 Muscle ($\sigma = 5.48$ mho/m, $\epsilon_r = 48.33$, $\rho = 1000$ kg/m³)

Phantom section: Flat Section; Space: 0.0cm from DUT to Flat Phantom

Test Date: 01-11-2006; Ambient Temp: 23.5°C; Tissue Temp: 21.5°C

Probe: EX3DV4 - SN3561; ConvF(4.1, 4.1, 4.1); Calibrated: 8/24/2005

Sensor-Surface: 3mm (Mechanical Surface Detection)

Electronics: DAE4 Sn649; Calibrated: 9/13/2005

Phantom: SAM Main; Type: SAM 4.0; Serial: TP:1197

Measurement SW: DASY4, V4.6 Build 19; Postprocessing SW: SEMCAD, V1.8 Build 159

Laptop position, LCD Open, Ch.52, 18Mbps, Aux Antenna

Area Scan (7x18x1): Measurement grid: dx=15mm, dy=15mm

Zoom Scan (5x5x7)/Cube 0: Measurement grid: dx=8mm, dy=8mm, dz=5mm

Reference Value = 3.27 V/m

Peak SAR (extrapolated) = 0.132 W/kg

SAR(1 g) = 0.064 mW/g; SAR(10 g) = 0.049 mW/g

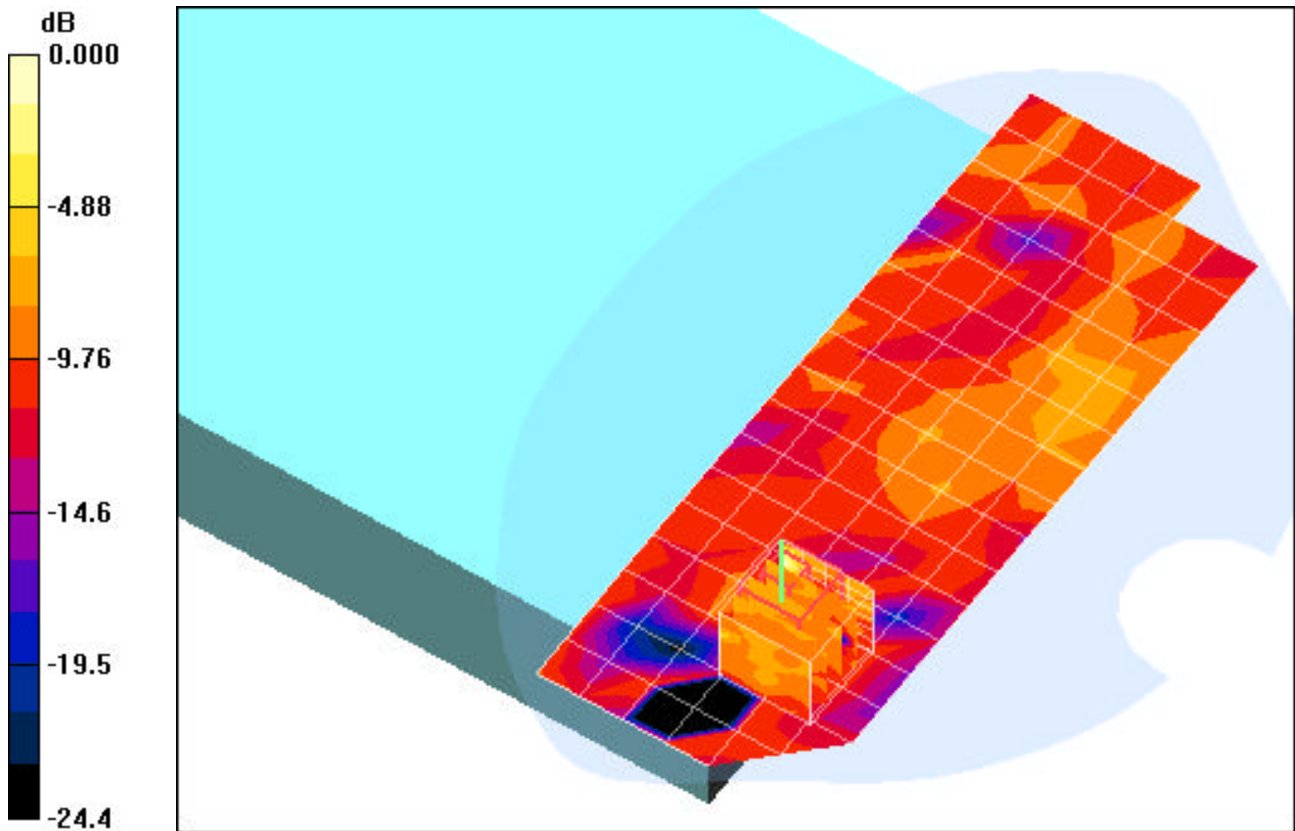

0 dB = 0.156mW/g

PCTEST ENGINEERING LABORATORY, INC.

DUT: CF-18; Type: Notebook PC with WLANa+b+g & Bluetooth & HSDPA; SN: 5KKS50328

Communication System: IEEE 802.11a; Frequency: 5785 MHz; Duty Cycle: 1:1

Medium: 5800 Muscle ($\sigma = 5.97$ mho/m, $\epsilon_r = 47.1$, $\rho = 1000$ kg/m³)

Phantom section: Flat Section; Space: 0.0cm from DUT to Flat Phantom

Test Date: 01-12-2005; Ambient Temp: 23.4°C; Tissue Temp: 21.5°C

Probe: EX3DV4 - SN3561; ConvF(3.63, 3.63, 3.63); Calibrated: 8/24/2005

Sensor-Surface: 3mm (Mechanical Surface Detection)

Electronics: DAE4 Sn649; Calibrated: 9/13/2005

Phantom: SAM Main; Type: SAM 4.0; Serial: TP:1197

Measurement SW: DASY4, V4.6 Build 19; Postprocessing SW: SEMCAD, V1.8 Build 159

Bystander position, LCD Open, Ch.157, 18Mbps, Main Antenna, Bluetooth Off

Area Scan (5x17x1): Measurement grid: dx=15mm, dy=15mm

Zoom Scan (5x5x7)/Cube 0: Measurement grid: dx=8mm, dy=8mm, dz=5mm

Reference Value = 2.53 V/m

Peak SAR (extrapolated) = 0.679 W/kg

SAR(1 g) = 0.396 mW/g; SAR(10 g) = 0.486 mW/g

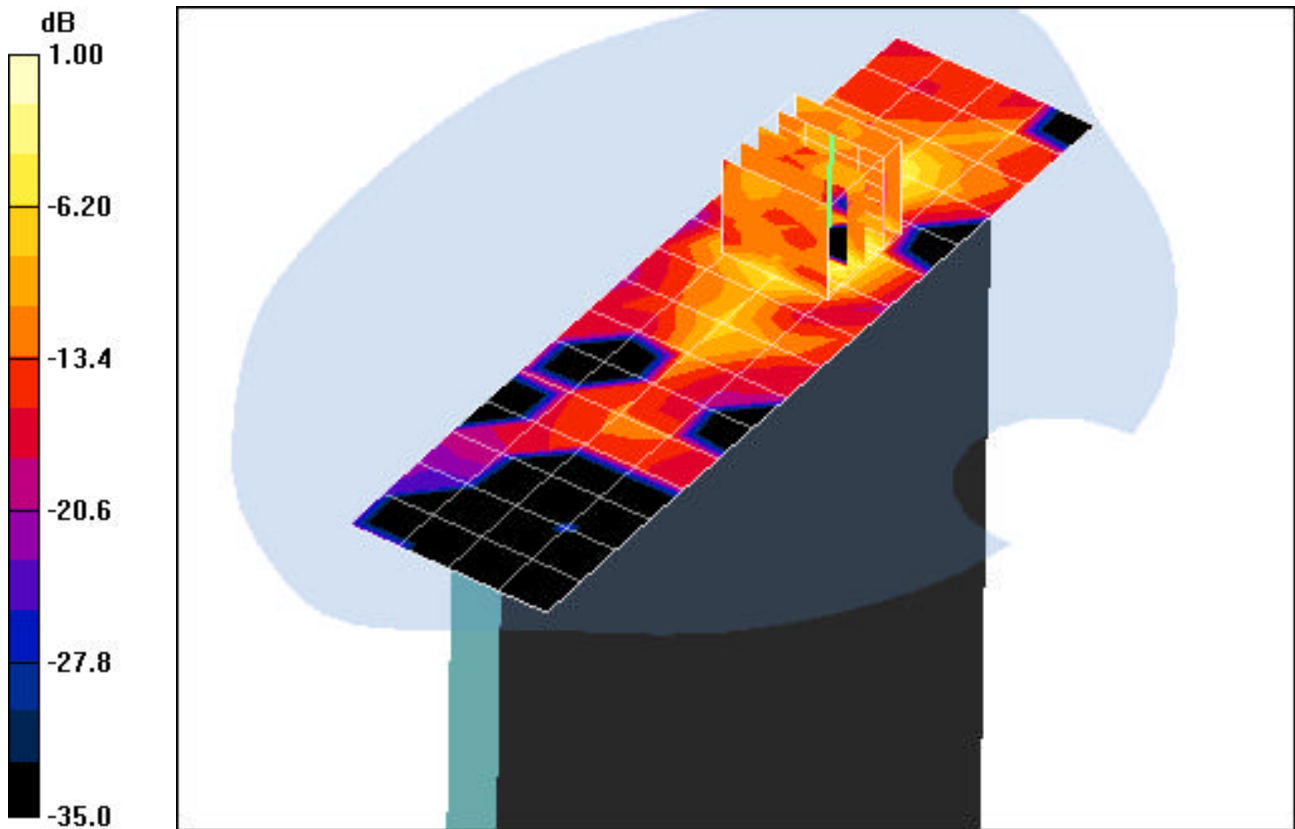

0 dB = 0.486mW/g

PCTEST ENGINEERING LABORATORY, INC.

DUT: CF-18; Type: Notebook PC with WLANa+b+g & Bluetooth & HSDPA; SN: 5KKS50328

Communication System: IEEE 802.11a; Frequency: 5785 MHz; Duty Cycle: 1:1

Medium: 5800 Muscle ($\sigma = 5.97$ mho/m, $\epsilon_r = 47.1$, $\rho = 1000$ kg/m³)

Phantom section: Flat Section; Space: 0.0cm from DUT to Flat Phantom

Test Date: 01-12-2006; Ambient Temp: 23.4°C; Tissue Temp: 21.5°C

Probe: EX3DV4 - SN3561; ConvF(3.63, 3.63, 3.63); Calibrated: 8/24/2005

Sensor-Surface: 3mm (Mechanical Surface Detection)

Electronics: DAE4 Sn649; Calibrated: 9/13/2005

Phantom: SAM Main; Type: SAM 4.0; Serial: TP:1197

Measurement SW: DASY4, V4.6 Build 19; Postprocessing SW: SEMCAD, V1.8 Build 159

Bystander position, LCD Open, Ch.157, 18Mbps, Aux Antenna

Area Scan (5x17x1): Measurement grid: dx=15mm, dy=15mm

Zoom Scan (5x5x7)/Cube 0: Measurement grid: dx=8mm, dy=8mm, dz=5mm

Reference Value = 2.49 V/m

Peak SAR (extrapolated) = 1.32 W/kg

SAR(1 g) = 0.401 mW/g; SAR(10 g) = 0.144 mW/g

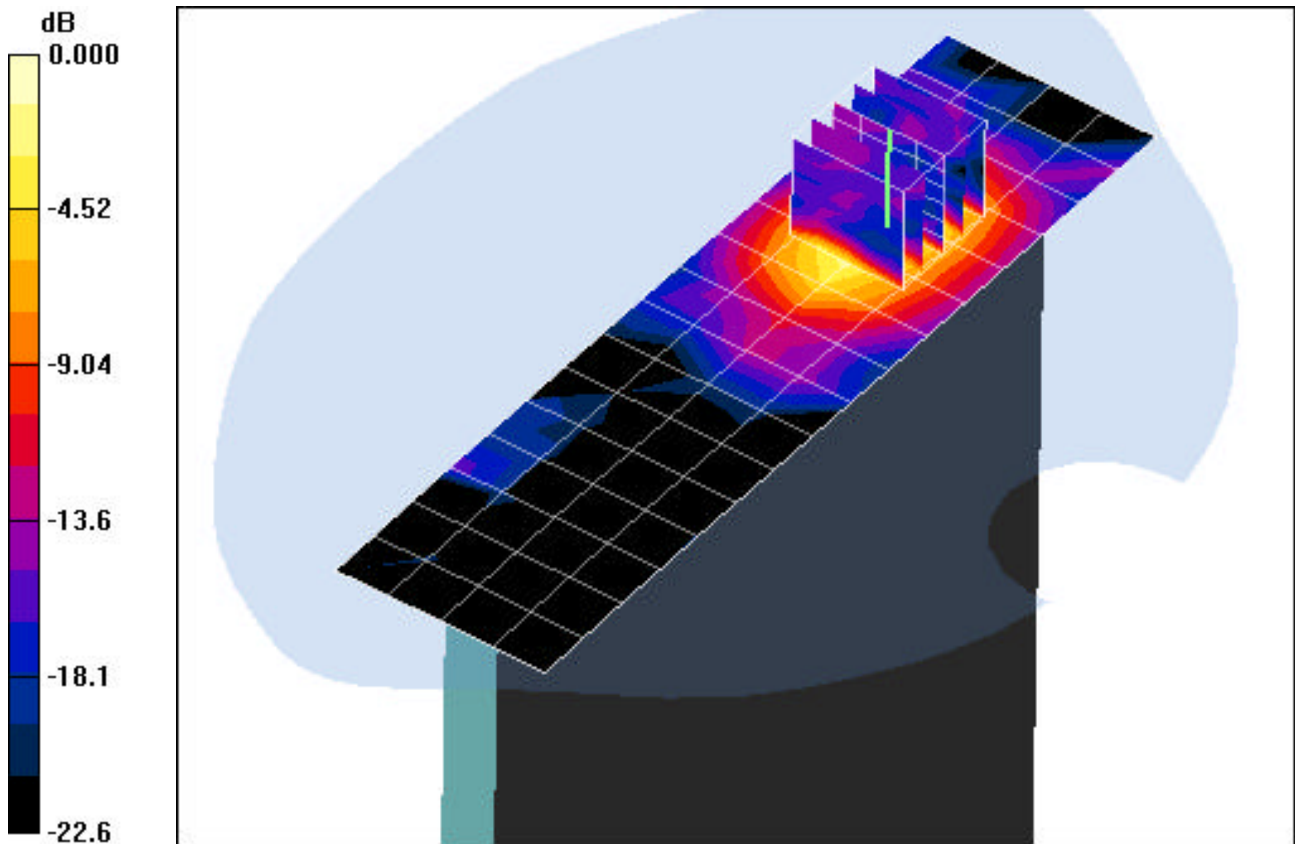

0 dB = 0.644mW/g

PCTEST ENGINEERING LABORATORY, INC.

DUT: CF -18; Type: Notebook PC with WLANa+b+g & Bluetooth & HSDPA; SN: 5KKS50328

Communication System: IEEE 802.11a; Frequency: 5785 MHz; Duty Cycle: 1:1

Medium: 5800 Muscle ($\sigma = 5.97$ mho/m, $\epsilon_r = 47.1$, $\rho = 1000$ kg/m³)

Phantom section: Flat Section; Space: 0.0cm from DUT to Flat Phantom

Test Date: 01-12-2006; Ambient Temp: 23.4°C; Tissue Temp: 21.5°C

Probe: EX3DV4 - SN3561; ConvF(3.63, 3.63, 3.63); Calibrated: 8/24/2005

Sensor-Surface: 3mm (Mechanical Surface Detection)

Electronics: DAE4 Sn649; Calibrated: 9/13/2005

Phantom: SAM Main; Type: SAM 4.0; Serial: TP:1197

Measurement SW: DASY4, V4.6 Build 19; Postprocessing SW: SEMCAD, V1.8 Build 159

Tablet position, LCD Flip, Ch.157, 18Mbps, Main Antenna, Bluetooth Off

Area Scan (7x17x1): Measurement grid: dx=15mm, dy=15mm

Zoom Scan (5x5x7)/Cube 0: Measurement grid: dx=8mm, dy=8mm, dz=5mm

Reference Value = 3.49 V/m

Peak SAR (extrapolated) = 1.21 W/kg

SAR(1 g) = 0.312 mW/g; SAR(10 g) = 0.093 mW/g

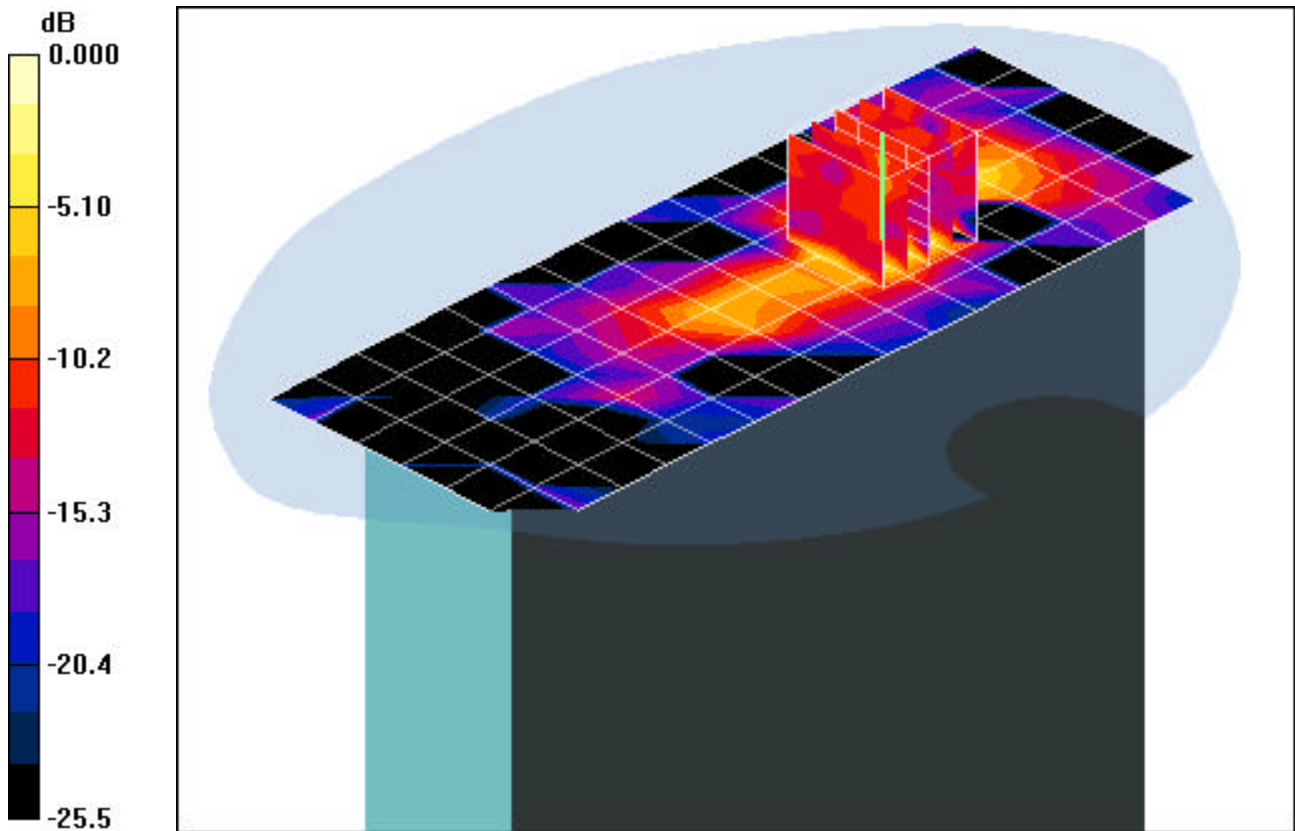

0 dB = 0.793mW/g

PCTEST ENGINEERING LABORATORY, INC.

DUT: CF-18; Type: Notebook PC with WLANa+b+g & Bluetooth 7HSDPA; SN: 5KKS50328

Communication System: IEEE 802.11a; Frequency: 5785 MHz; Duty Cycle: 1:1

Medium: 5800 Muscle ($\sigma = 5.97$ mho/m, $\epsilon_r = 47.1$, $\rho = 1000$ kg/m³)

Phantom section: Flat Section; Space: 0.0cm from DUT to Flat Phantom

Test Date: 01-12-2006; Ambient Temp: 23.4°C; Tissue Temp: 21.5°C

Probe: EX3DV4 - SN3561; ConvF(3.63, 3.63, 3.63); Calibrated: 8/24/2005

Sensor-Surface: 3mm (Mechanical Surface Detection)

Electronics: DAE4 Sn649; Calibrated: 9/13/2005

Phantom: SAM Main; Type: SAM 4.0; Serial: TP:1197

Measurement SW: DASY4, V4.6 Build 19; Postprocessing SW: SEMCAD, V1.8 Build 159

Tablet position, LCD Flip, Touch, Ch.157, 18Mbps, Aux Antenna

Area Scan (7x17x1): Measurement grid: dx=15mm, dy=15mm

Zoom Scan (5x5x7)/Cube 0: Measurement grid: dx=8mm, dy=8mm, dz=5mm

Reference Value = 3.83 V/m

Peak SAR (extrapolated) = 1.17 W/kg

SAR(1 g) = 0.373 mW/g; SAR(10 g) = 0.135 mW/g

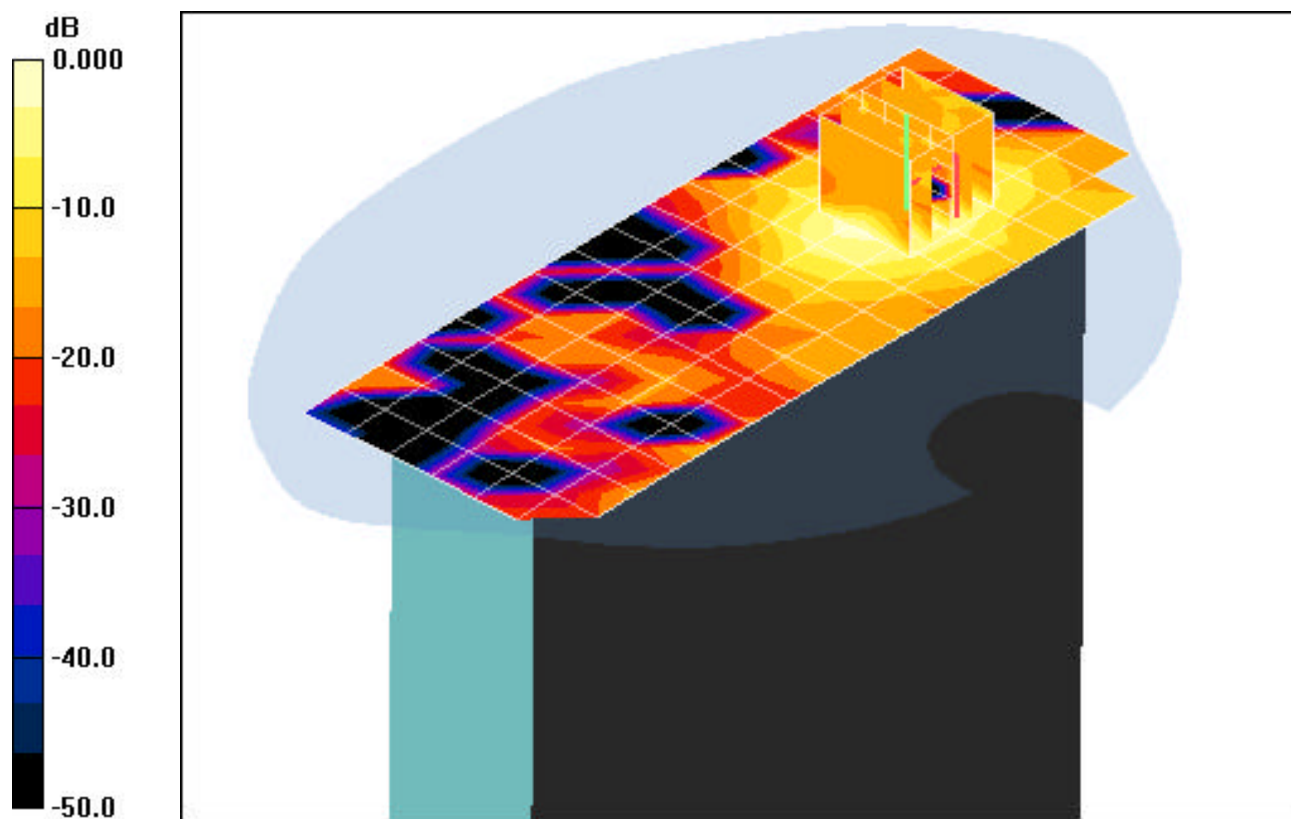

0 dB = 0.601mW/g

PCTEST ENGINEERING LABORATORY, INC.

DUT: CF-18; Type: Notebook PC with WLANa+b+g & Bluetooth & HSDPA; SN: 5KKS50328

Communication System: IEEE 802.11a; Frequency: 5785 MHz; Duty Cycle: 1:1

Medium: 5800 Muscle ($\sigma = 5.97$ mho/m, $\epsilon_r = 47.1$, $\rho = 1000$ kg/m³)

Phantom section: Flat Section; Space: 0.0cm from DUT to Flat Phantom

Test Date: 01-12-2006; Ambient Temp: 23.4°C; Tissue Temp: 21.5°C

Probe: EX3DV4 - SN3561; ConvF(3.63, 3.63, 3.63); Calibrated: 8/24/2005

Sensor-Surface: 3mm (Mechanical Surface Detection)

Electronics: DAE4 Sn649; Calibrated: 9/13/2005

Phantom: SAM Main; Type: SAM 4.0; Serial: TP:1197

Measurement SW: DASY4, V4.6 Build 19; Postprocessing SW: SEMCAD, V1.8 Build 159

Laptop position, LCD Flip, Ch.157, 18Mbps, Main Antenna, Bluetooth Off

Area Scan (7x18x1): Measurement grid: dx=15mm, dy=15mm

Zoom Scan (5x5x7)/Cube 0: Measurement grid: dx=8mm, dy=8mm, dz=5mm

Reference Value = 1.19V/m

Peak SAR (extrapolated) = 0.130 W/kg

SAR(1 g) = 0.038 mW/g; SAR(10 g) = 0.00645 mW/g

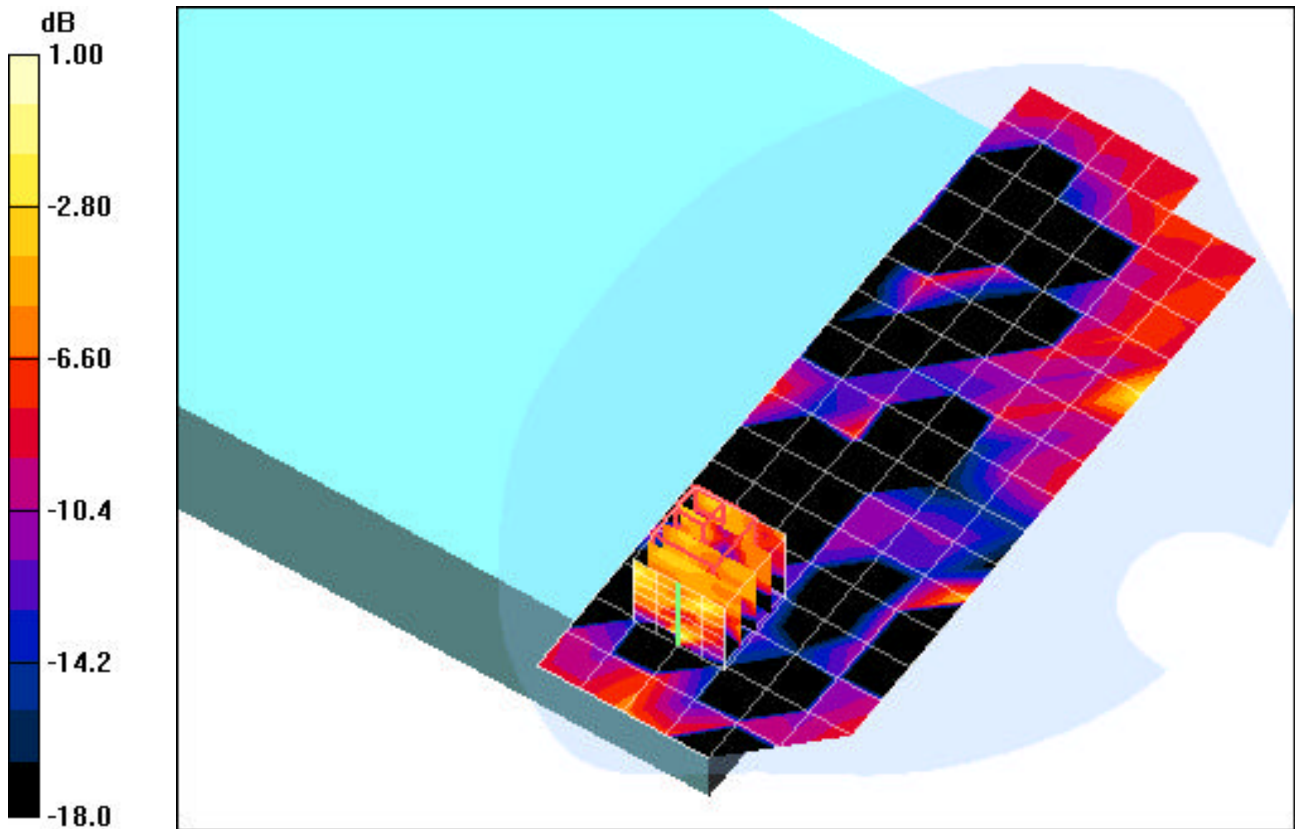

0 dB = 0.080mW/g

PCTEST ENGINEERING LABORATORY, INC.

DUT: CF-18; Type: Notebook PC with WLANa+b+g & Bluetooth & HSDPA; SN: 5KKS50328

Communication System: IEEE 802.11a; Frequency: 5785 MHz; Duty Cycle: 1:1

Medium: 5800 Muscle ($\sigma = 5.97$ mho/m, $\epsilon_r = 47.1$, $\rho = 1000$ kg/m³)

Phantom section: Flat Section; Space: 0.0cm from DUT to Flat Phantom

Test Date: 01-12-2006; Ambient Temp: 23.4°C; Tissue Temp: 21.5°C

Probe: EX3DV4 - SN3561; ConvF(3.63, 3.63, 3.63); Calibrated: 8/24/2005

Sensor-Surface: 3mm (Mechanical Surface Detection)

Electronics: DAE4 Sn649; Calibrated: 9/13/2005

Phantom: SAM Main; Type: SAM 4.0; Serial: TP:1197

Measurement SW: DASY4, V4.6 Build 19; Postprocessing SW: SEMCAD, V1.8 Build 159

Laptop position, LCD Flip, Ch.157, 18Mbps, Aux Antenna

Area Scan (7x18x1): Measurement grid: dx=15mm, dy=15mm

Zoom Scan (5x5x7)/Cube 0: Measurement grid: dx=8mm, dy=8mm, dz=5mm

Reference Value = 1.64 V/m

Peak SAR (extrapolated) = 0.092 W/kg

SAR(1 g) = 0.054 mW/g; SAR(10 g) = 0.034 mW/g

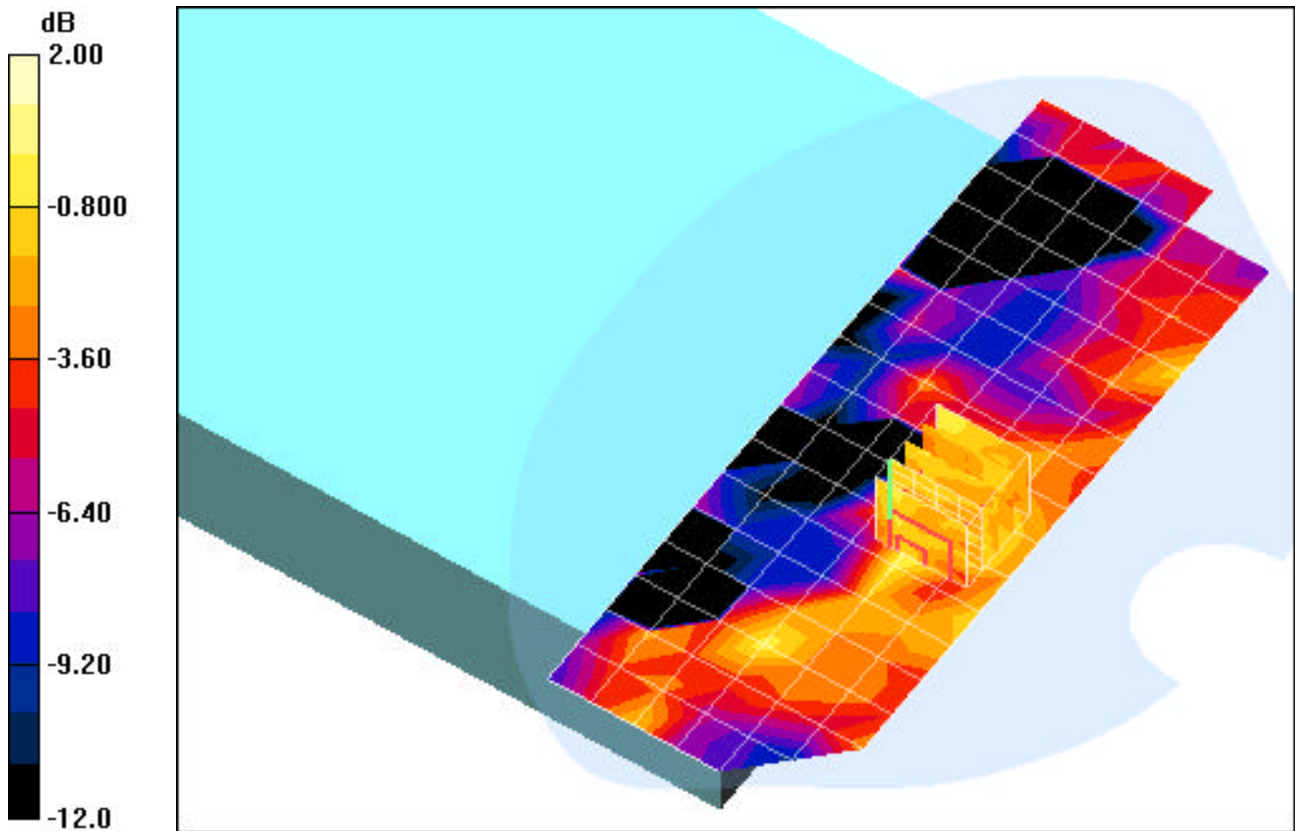

0 dB = 0.086mW/g

PCTEST ENGINEERING LABORATORY, INC.

DUT: CF-18; Type: Notebook PC with WLANa+b+g & Bluetooth & HSDPA; SN: 5KKS50328

Communication System: GSM 850 GPRS; 2 Tx slots; Frequency: 836.6 MHz; Duty Cycle: 1:4.15

Medium: 835 Muscle ($\sigma = 0.99$ mho/m, $\epsilon_r = 54.73$, $\rho = 1000$ kg/m³)

Phantom section: Flat Section; Space: 0.0cm from DUT to Flat Phantom

Test Date: 01-09-2006; Ambient Temp: 23.5°C; Tissue Temp: 21.6°C

Probe: EX3DV4 - SN3561; ConvF(7.9, 7.9, 7.9); Calibrated: 8/24/2005

Sensor-Surface: 3mm (Mechanical Surface Detection)

Electronics: DAE4 Sn649; Calibrated: 9/13/2005

Phantom: SAM Main; Type: SAM 4.0; Serial: TP:1197

Measurement SW: DASY4, V4.6 Build 19; Postprocessing SW: SEMCAD, V1.8 Build 159

Tablet Position, LCD Flip, Ch.190,+WLAN 802.11b, Ch.06, 5.5mbps

Area Scan (7x17x1): Measurement grid: dx=15mm, dy=15mm

Zoom Scan (5x5x7)/Cube 0: Measurement grid: dx=8mm, dy=8mm, dz=5mm

Reference Value = 10.3 V/m

Peak SAR (extrapolated) = 0.952 W/kg

SAR(1 g) = 0.611 mW/g; SAR(10 g) = 0.385 mW/g

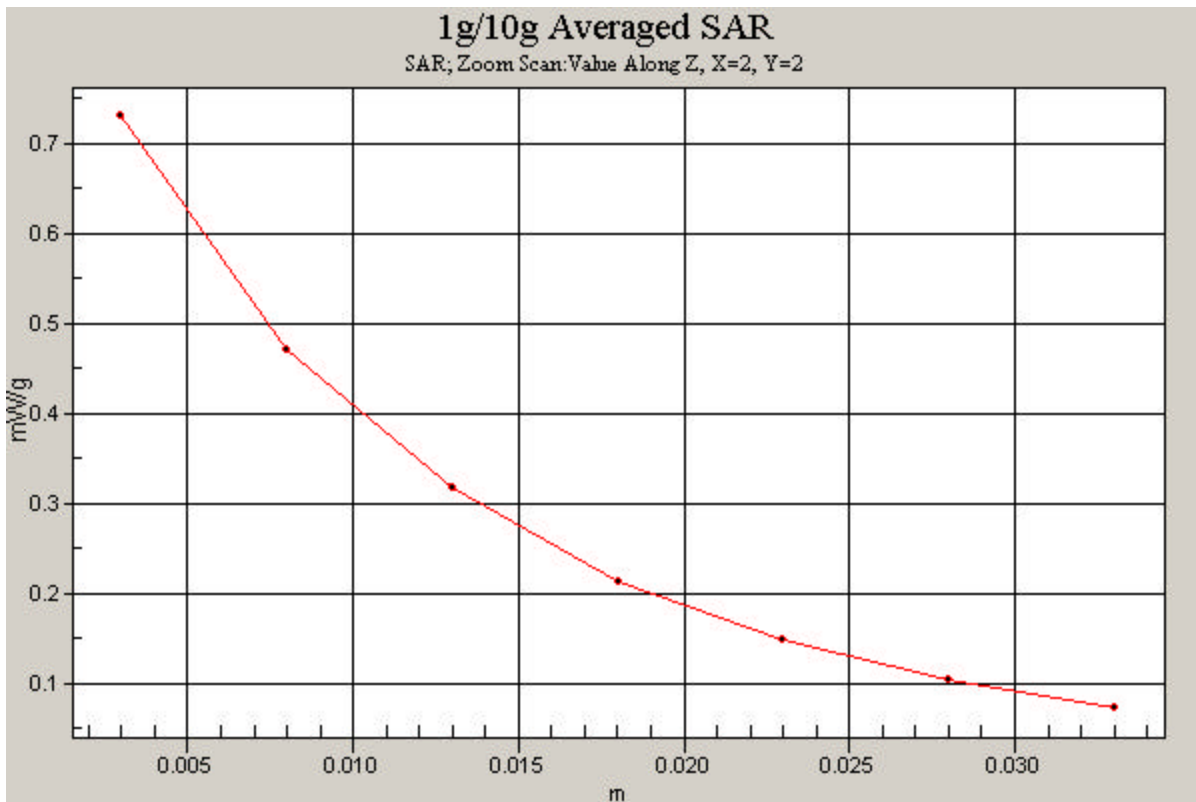

PCTEST ENGINEERING LABORATORY, INC.

DUT: CF-18; Type: Notebook PC with WLANa+b+g & Bluetooth & HSDPA; SN: 5KKS50328

Communication System: GSM1900 GPRS; Frequency: 1880 MHz; Duty Cycle: 1:4.15

Medium: 1900 Muscle ($\sigma = 1.57$ mho/m, $\epsilon_r = 52.8$, $\rho = 1000$ kg/m³)

Phantom section: Flat Section; Space: 0.0cm from DUT to Flat Phantom

Test Date: 01-09-2006; Ambient Temp: 23.5°C; Tissue Temp: 21.6°C

Probe: EX3DV4 - SN3561; ConvF(6.48, 6.48, 6.48); Calibrated: 8/24/2005

Sensor-Surface: 3mm (Mechanical Surface Detection)

Electronics: DAE4 Sn649; Calibrated: 9/13/2005

Phantom: SAM Sub; Type: SAM 4.0; Serial: TP:1357

Measurement SW: DASY4, V4.6 Build 19; Postprocessing SW: SEMCAD, V1.8 Build 159

Bystander position, LCD Open, Ch.661, w/ WLAN 802.11b, Ch.06, 5.5mbps

Area Scan (5x17x1): Measurement grid: dx=15mm, dy=15mm

Zoom Scan (5x5x7)/Cube 0: Measurement grid: dx=8mm, dy=8mm, dz=5mm

Reference Value = 9.20 V/m

Peak SAR (extrapolated) = 0.596 W/kg

SAR(1 g) = 0.350 mW/g; SAR(10 g) = 0.194 mW/g

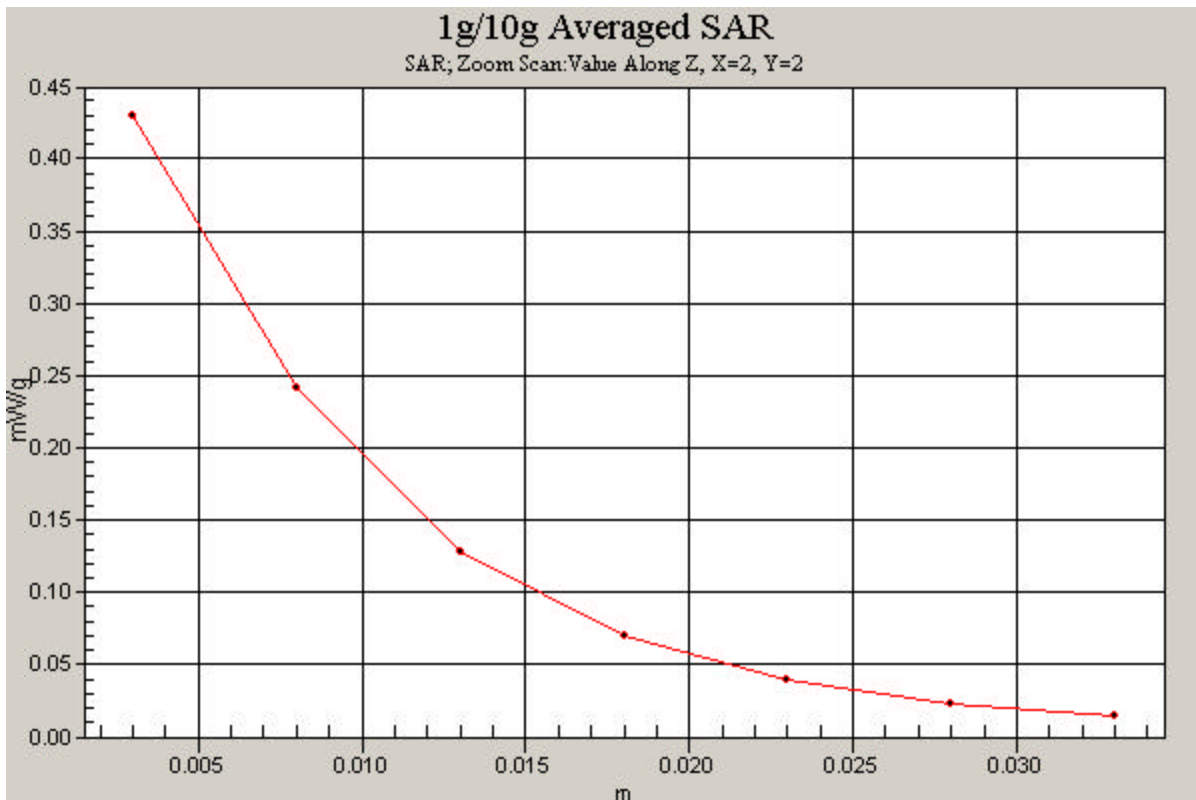

PCTEST ENGINEERING LABORATORY, INC.

DUT: CF-18; Type: Notebook PC with WLANa+b+g & Bluetooth & HSDPA; SN: 5KKS50328

Communication System: IEEE 802.11b; Frequency: 2437 MHz; Duty Cycle: 1:1

Medium: 2450 Muscle ($\sigma = 1.93$ mho/m, $\epsilon_r = 54.0$, $\rho = 1000$ kg/m³)

Phantom section: Flat Section; Space: 0.0cm from DUT to Flat Phantom

Test Date: 01-04-2006; Ambient Temp: 23.4°C; Tissue Temp: 21.5°C

Probe: EX3DV4 - SN3561; ConvF(6.3, 6.3, 6.3); Calibrated: 8/24/2005

Sensor-Surface: 3mm (Mechanical Surface Detection)

Electronics: DAE4 Sn649; Calibrated: 9/13/2005

Phantom: SAM Main; Type: SAM 4.0; Serial: TP:1197

Measurement SW: DASY4, V4.6 Build 19; Postprocessing SW: SEMCAD, V1.8 Build 159

Bystander position, LCD Open, Ch.06, 5.5Mbps, Aux Antenna

Area Scan (5x17x1): Measurement grid: dx=15mm, dy=15mm

Zoom Scan (5x5x7)/Cube 0: Measurement grid: dx=8mm, dy=8mm, dz=5mm

Reference Value = 2.12 V/m

Peak SAR (extrapolated) = 0.403 W/kg

SAR(1 g) = 0.217 mW/g; SAR(10 g) = 0.117 mW/g

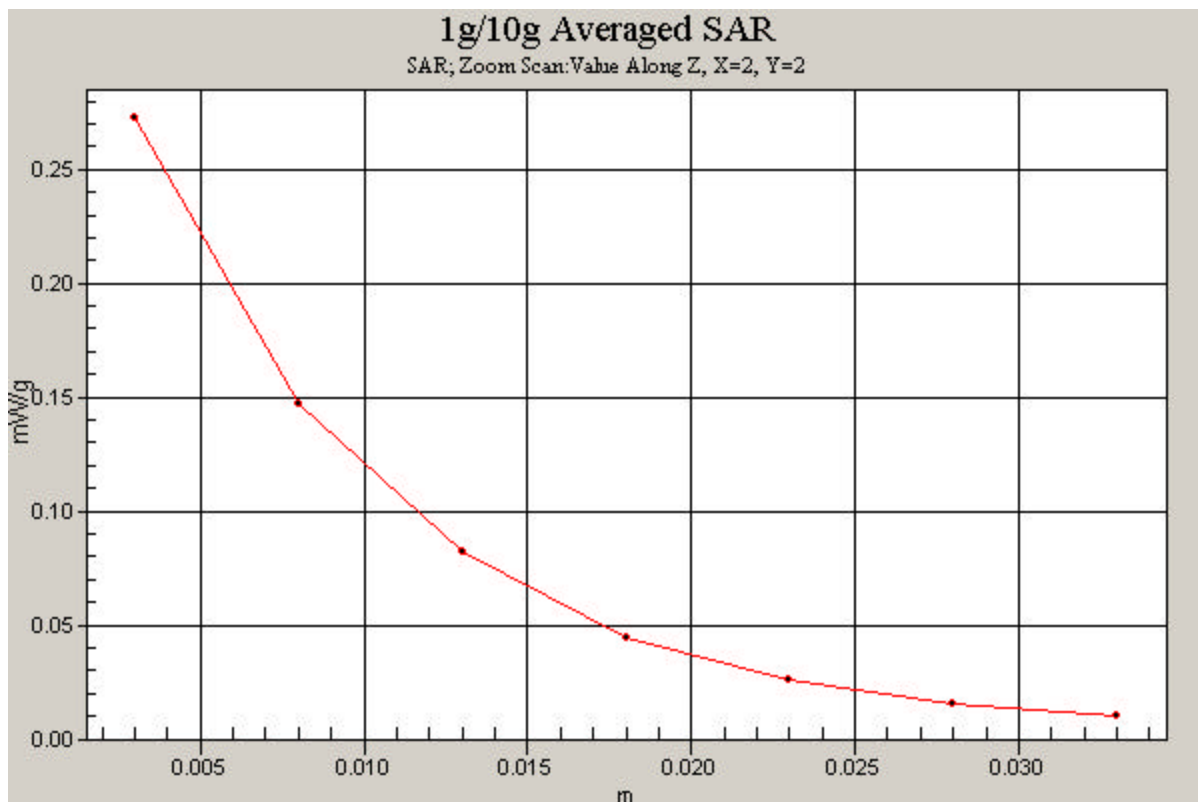

PCTEST ENGINEERING LABORATORY, INC.

DUT: CF-18; Type: Notebook PC with WLANa+b+g & Bluetooth & HSDPA; SN: 5KKS50328

Communication System: IEEE 802.11a; Frequency: 5260 MHz; Duty Cycle: 1:1

Medium: 5300 Muscle ($\sigma = 5.48$ mho/m, $\epsilon_r = 48.33$, $\rho = 1000$ kg/m³)

Phantom section: Flat Section; Space: 0.0cm from DUT to Flat Phantom

Test Date: 01-11-2006; Ambient Temp: 23.5°C; Tissue Temp: 21.5°C

Probe: EX3DV4 - SN3561; ConvF(4.1, 4.1, 4.1); Calibrated: 8/24/2005

Sensor-Surface: 3mm (Mechanical Surface Detection)

Electronics: DAE4 Sn649; Calibrated: 9/13/2005

Phantom: SAM Main; Type: SAM 4.0; Serial: TP:1197

Measurement SW: DASY4, V4.6 Build 19; Postprocessing SW: SEMCAD, V1.8 Build 159

Bystander position, LCD Open, Ch.52, 18Mbps, Aux Antenna

Area Scan (5x17x1): Measurement grid: dx=15mm, dy=15mm

Zoom Scan (5x5x7)/Cube 0: Measurement grid: dx=8mm, dy=8mm, dz=5mm

Reference Value = 3.70 V/m

Peak SAR (extrapolated) = 3.92 W/kg

SAR(1 g) = 0.841 mW/g; SAR(10 g) = 0.306 mW/g

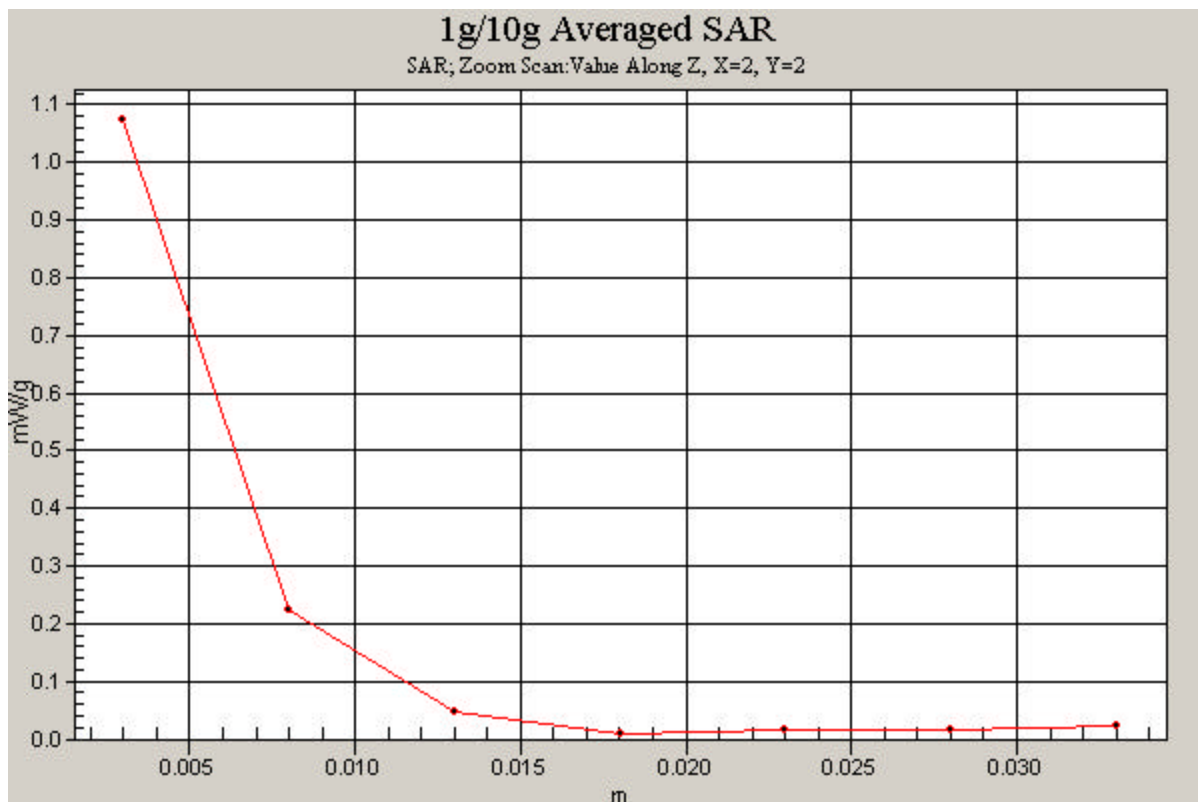

PCTEST ENGINEERING LABORATORY, INC.

DUT: CF-18; Type: Notebook PC with WLANa+b+g & Bluetooth & HSDPA; SN: 5KKS50328

Communication System: IEEE 802.11a; Frequency: 5785 MHz; Duty Cycle: 1:1

Medium: 5800 Muscle ($\sigma = 5.97$ mho/m, $\epsilon_r = 47.1$, $\rho = 1000$ kg/m³)

Phantom section: Flat Section; Space: 0.0cm from DUT to Flat Phantom

Test Date: 01-12-2006; Ambient Temp: 23.4°C; Tissue Temp: 21.5°C

Probe: EX3DV4 - SN3561; ConvF(3.63, 3.63, 3.63); Calibrated: 8/24/2005

Sensor-Surface: 3mm (Mechanical Surface Detection)

Electronics: DAE4 Sn649; Calibrated: 9/13/2005

Phantom: SAM Main; Type: SAM 4.0; Serial: TP:1197

Measurement SW: DASY4, V4.6 Build 19; Postprocessing SW: SEMCAD, V1.8 Build 159

Bystander position, LCD Open, Ch.157, 18Mbps, Main Antenna

Area Scan (5x17x1): Measurement grid: dx=15mm, dy=15mm

Zoom Scan (5x5x7)/Cube 0: Measurement grid: dx=8mm, dy=8mm, dz=5mm

Reference Value = 2.49 V/m

Peak SAR (extrapolated) = 1.32 W/kg

SAR(1 g) = 0.401 mW/g; SAR(10 g) = 0.144 mW/g

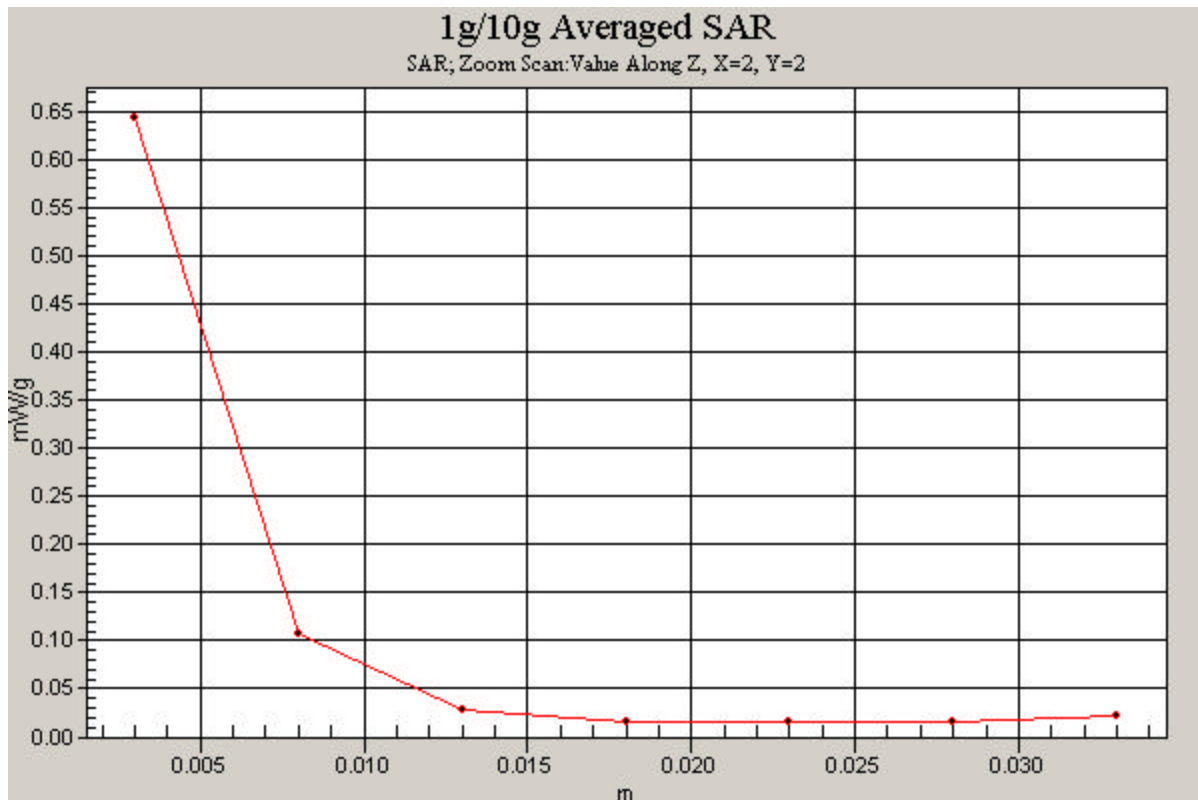

APPENDIX B: DIPOLE VALIDATION

PCTEST ENGINEERING LABORATORY, INC.

DUT: Dipole 2450 MHz; Type: D2450V2; SN: 719

Communication System: CW; Frequency: 2450 MHz; Duty Cycle: 1:1

Medium: 2450 Brain ($\sigma = 1.82$ mho/m, $\epsilon_r = 38.64$, $\rho = 1000$ kg/m³)

Phantom section: Flat Section

Test Date: 01-04-2006; Ambient Temp: 23.4°C; Tissue Temp: 21.5°C

Probe: EX3DV4 - SN3561; ConvF(6.37, 6.37, 6.37); Calibrated: 8/24/2005

Sensor-Surface: 3mm (Mechanical Surface Detection)

Electronics: DAE4 Sn649; Calibrated: 9/13/2005

Phantom: SAM Main; Type: SAM 4.0; Serial: TP:1197

Measurement SW: DASY4, V4.6 Build 19; Postprocessing SW: SEMCAD, V1.8 Build 159

2450MHz Dipole Validation

Area Scan (5x7x1): Measurement grid: dx=15mm, dy=15mm

Zoom Scan (5x5x7)/Cube 0: Measurement grid: dx=8mm, dy=8mm, dz=5mm

Input Power = 20.0 dBm (100mW)

SAR(1 g) = 5.06 mW/g; SAR(10 g) = 2.47 mW/g

Target SAR(1 g) = 5.24 mW/g; Deviation = -3.43%

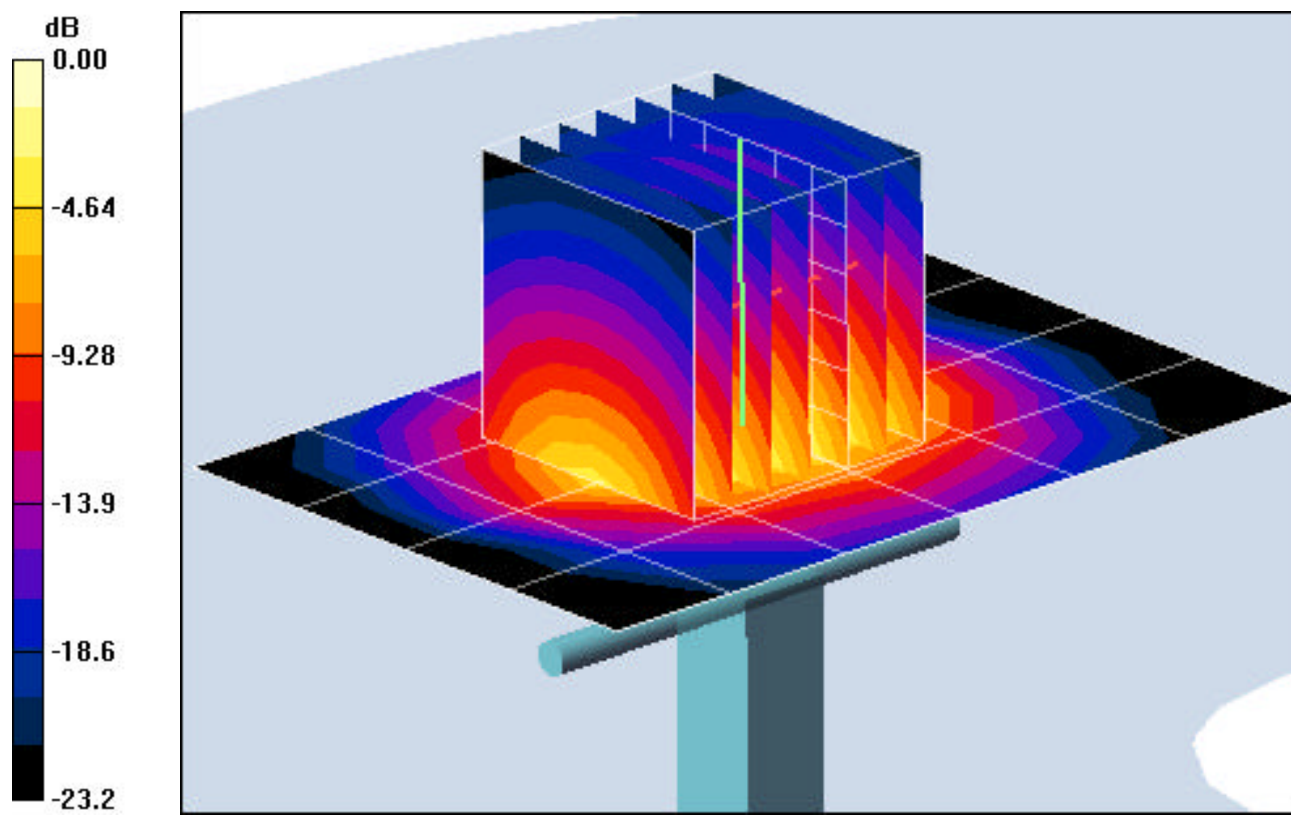

0 dB = 7.53mW/g

PCTEST ENGINEERING LABORATORY, INC.

DUT: Dipole 2450 MHz; Type: D2450V2; SN: 719

Communication System: CW; Frequency: 2450 MHz; Duty Cycle: 1:1

Medium: 2450 Brain ($\sigma = 1.82$ mho/m, $\epsilon_r = 38.64$, $\rho = 1000$ kg/m³)

Phantom section: Flat Section

Test Date: 01-05-2006; Ambient Temp: 23.2°C; Tissue Temp: 21.4°C

Probe: EX3DV4 - SN3561; ConvF(6.37, 6.37, 6.37); Calibrated: 8/24/2005

Sensor-Surface: 3mm (Mechanical Surface Detection)

Electronics: DAE4 Sn649; Calibrated: 9/13/2005

Phantom: SAM Main; Type: SAM 4.0; Serial: TP:1197

Measurement SW: DASY4, V4.6 Build 19; Postprocessing SW: SEMCAD, V1.8 Build 159

2450MHz Dipole Validation

Area Scan (5x7x1): Measurement grid: dx=15mm, dy=15mm

Zoom Scan (5x5x7)/Cube 0: Measurement grid: dx=8mm, dy=8mm, dz=5mm

Input Power = 20.0 dBm (100mW)

SAR(1 g) = 5.1 mW/g; SAR(10 g) = 2.58 mW/g

Target SAR(1 g) = 5.24 mW/g; Deviation = -2.67%

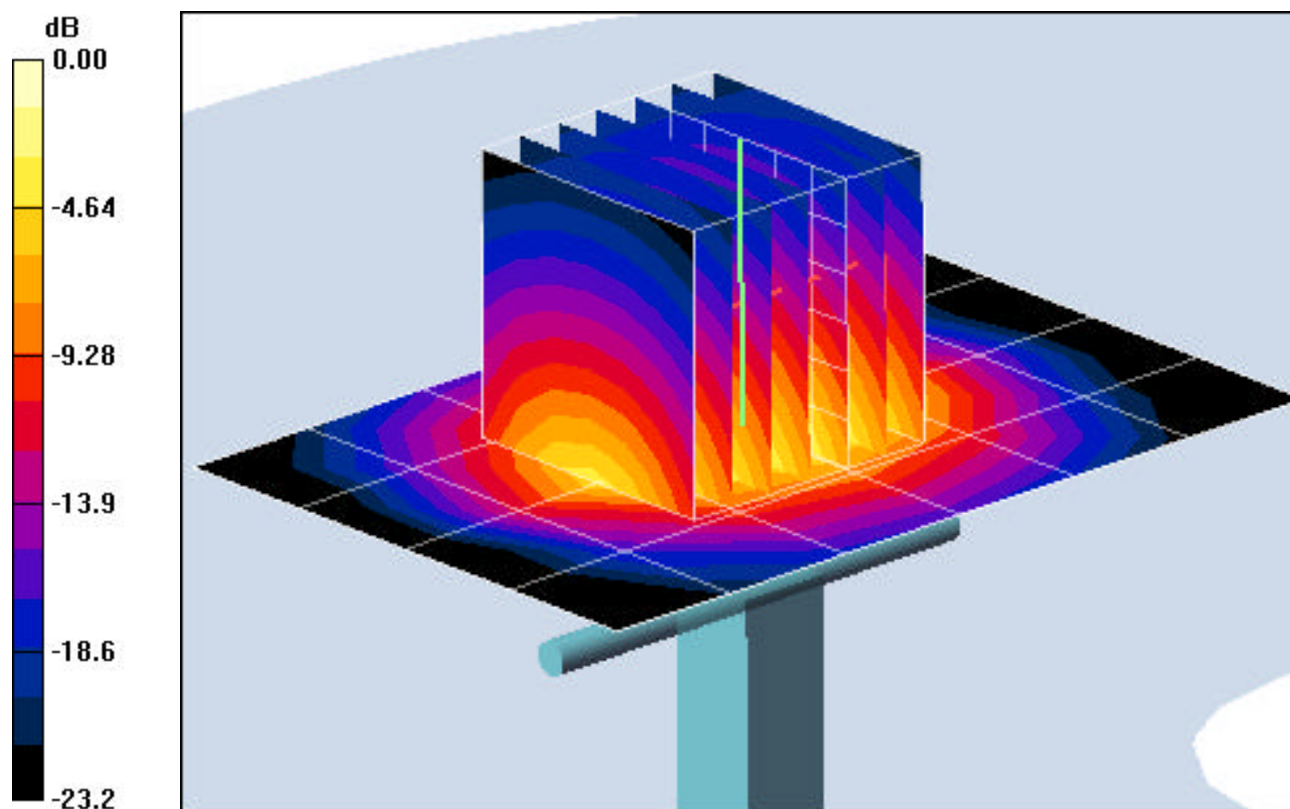

0 dB = 7.62mW/g

PCTEST ENGINEERING LABORATORY, INC.

DUT: Dipole 835 MHz; Type: D835V2; Serial: 4d026

Communication System: CW; Frequency: 835 MHz; Duty Cycle: 1:1

Medium: 835 Brain ($\sigma = 0.92$ mho/m, $\epsilon_r = 42.75$, $\rho = 1000$ kg/m³)

Phantom section: Flat Section; Space: 1.5 cm

Test Date: 01-09-2006; Ambient Temp: 23.5°C; Tissue Temp: 21.6°C

Probe: EX3DV4 - SN3561; ConvF(7.91, 7.91, 7.91); Calibrated: 8/24/2005

Sensor-Surface: 3mm (Mechanical Surface Detection)

Electronics: DAE4 Sn649; Calibrated: 9/13/2005

Phantom: SAM Main; Type: SAM 4.0; Serial: TP:1197

Measurement SW: DASY4, V4.6 Build 19; Postprocessing SW: SEMCAD, V1.8 Build 159

835MHz Dipole Validation

Area Scan (7x13x1): Measurement grid: dx=15mm, dy=15mm

Zoom Scan (5x5x7)/Cube 0: Measurement grid: dx=8mm, dy=8mm, dz=5mm

Input Power = 24.0 dBm (250 mW)

SAR(1 g) = 2.43 mW/g; SAR(10 g) = 1.58 mW/g

Target SAR(1g) = 2.375 mW/g; Deviation = +2.31 %

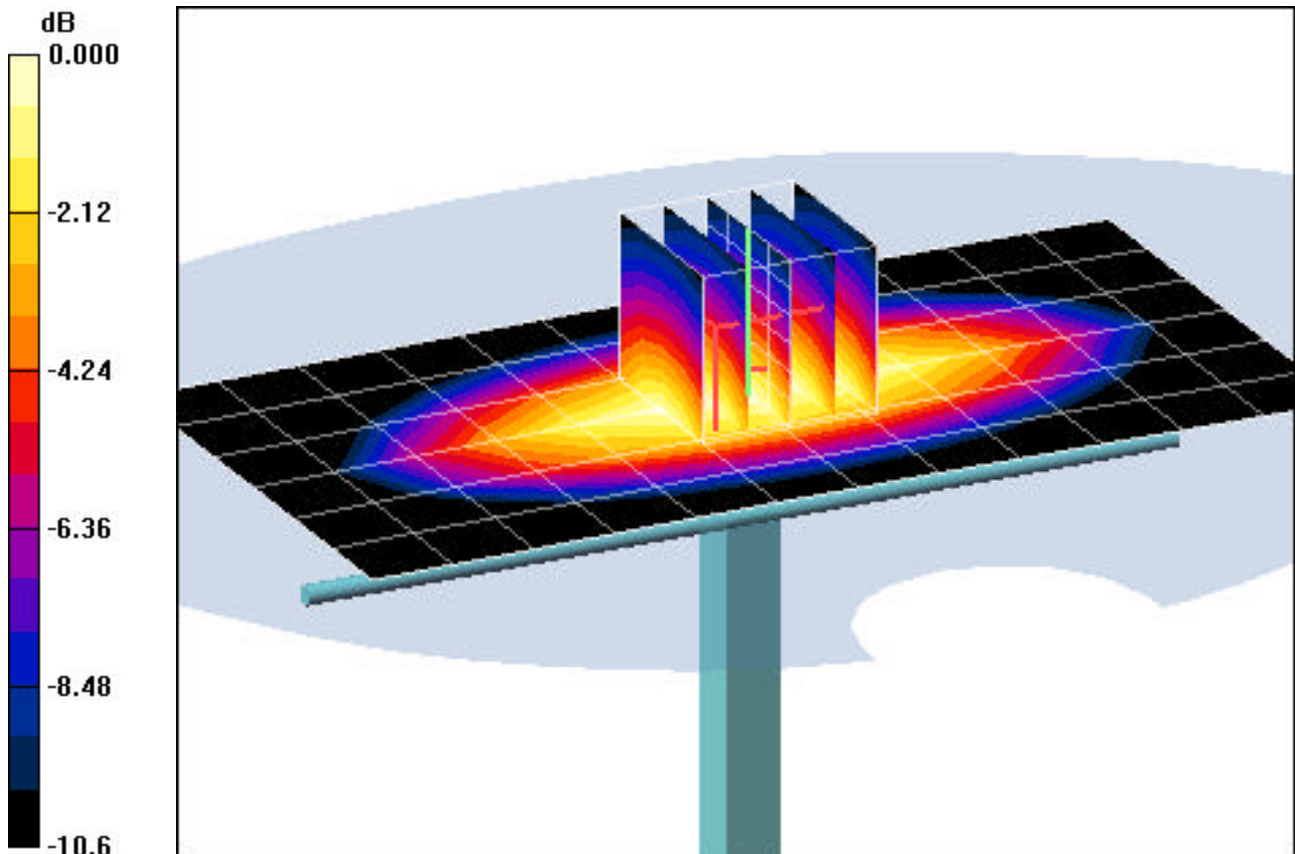

0 dB = 2.82mW/g

PCTEST ENGINEERING LABORATORY, INC.

DUT: Dipole 1900 MHz; Type: D1900V2; Serial: 502

Communication System: CW; Frequency: 1900 MHz; Duty Cycle: 1:1

Medium: 1900 Brain ($\sigma = 1.46$ mho/m, $\epsilon_r = 39.10$, $\rho = 1000$ kg/m³)

Phantom section: Flat Section; Space: 1.0 cm

Test Date: 01-09-2006; Ambient Temp: 23.5°C; Tissue Temp: 21.6°C

Probe: EX3DV4 - SN3561; ConvF(7.04, 7.04, 7.04); Calibrated: 8/24/2005

Sensor-Surface: 3mm (Mechanical Surface Detection)

Electronics: DAE4 Sn649; Calibrated: 9/13/2005

Phantom: SAM Sub; Type: SAM 4.0; Serial: TP:1357

Measurement SW: DASY4, V4.6 Build 19; Postprocessing SW: SEMCAD, V1.8 Build 159

1900MHz Dipole Validation

Area Scan (5x7x1): Measurement grid: dx=15mm, dy=15mm

Zoom Scan (5x5x7)/Cube 0: Measurement grid: dx=8mm, dy=8mm, dz=5mm

Input Power = 20.0 dBm (100 mW)

SAR(1 g) = 4.17 mW/g; SAR(10 g) = 2.31 mW/g

Target SAR(1g) = 3.97 mW/g; Deviation = +5.03 %

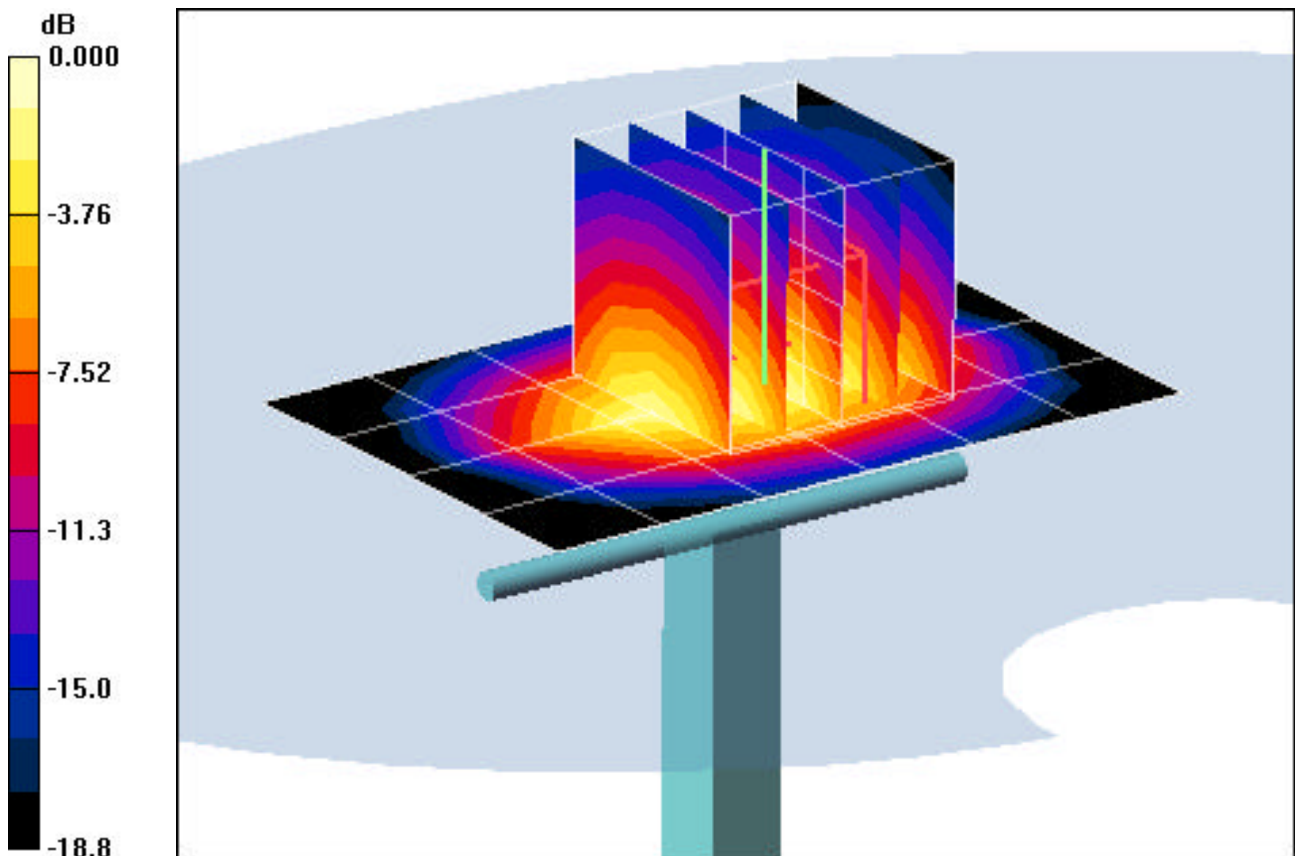

0 dB = 5.24mW/g

PCTEST ENGINEERING LABORATORY, INC.

DUT: Dipole 835 MHz; Type: D835V2; Serial: 4d026

Communication System: CW; Frequency: 835 MHz; Duty Cycle: 1:1

Medium: 835 Brain ($\sigma = 0.92$ mho/m, $\epsilon_r = 42.75$, $\rho = 1000$ kg/m³)

Phantom section: Flat Section; Space: 1.5 cm

Test Date: 01-10-2006; Ambient Temp: 23.6°C; Tissue Temp: 21.7°C

Probe: EX3DV4 - SN3561; ConvF(7.91, 7.91, 7.91); Calibrated: 8/24/2005

Sensor-Surface: 3mm (Mechanical Surface Detection)

Electronics: DAE4 Sn649; Calibrated: 9/13/2005

Phantom: SAM Main; Type: SAM 4.0; Serial: TP:1197

Measurement SW: DASY4, V4.6 Build 19; Postprocessing SW: SEMCAD, V1.8 Build 159

835MHz Dipole Validation

Area Scan (7x13x1): Measurement grid: dx=15mm, dy=15mm

Zoom Scan (5x5x7)/Cube 0: Measurement grid: dx=8mm, dy=8mm, dz=5mm

Input Power = 24.0 dBm (250 mW)

SAR(1 g) = 2.45 mW/g; SAR(10 g) = 1.64 mW/g

Target SAR(1g) = 2.375 mW/g; Deviation = +3.15 %

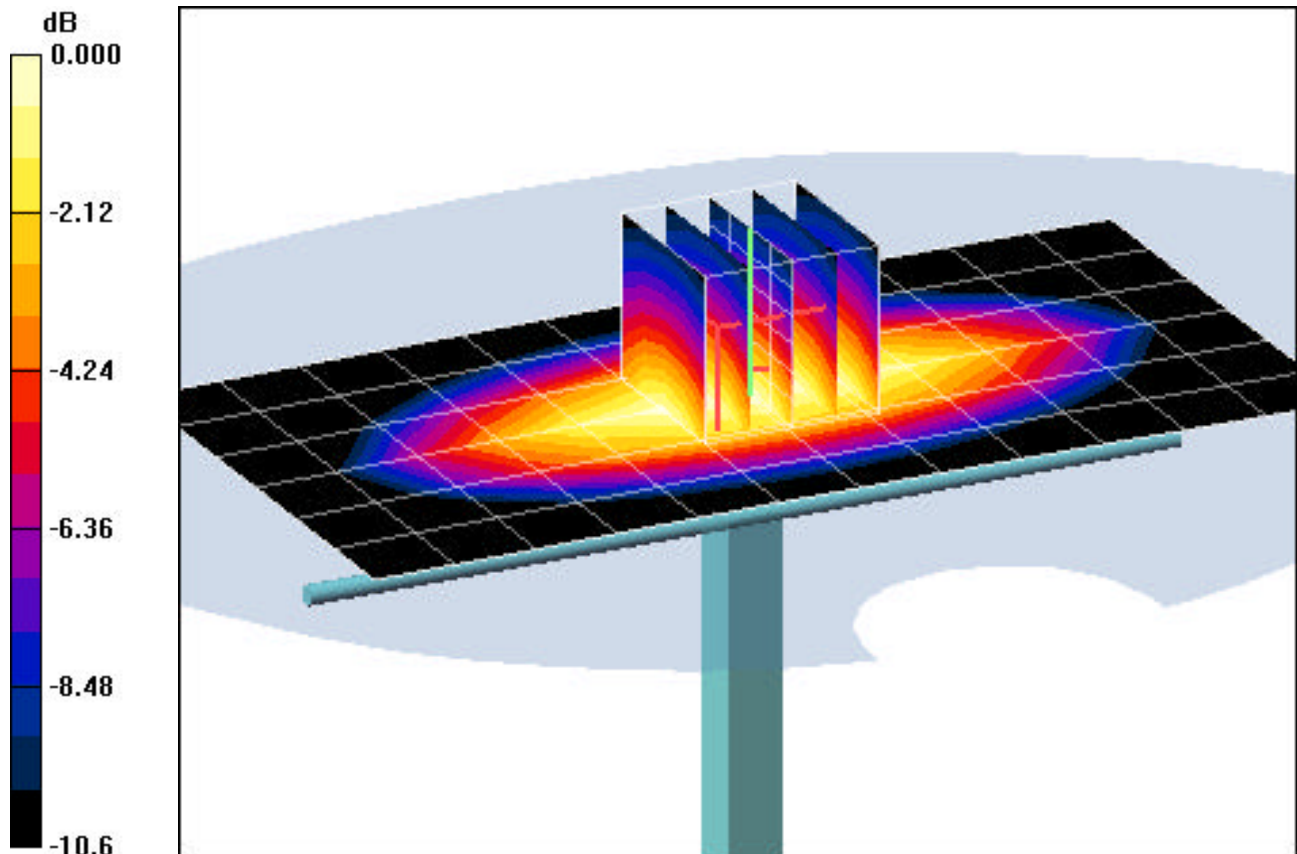

0 dB = 2.91mW/g

PCTEST ENGINEERING LABORATORY, INC.

DUT: Dipole 1900 MHz; Type: D1900V2; Serial: 502

Communication System: CW; Frequency: 1900 MHz; Duty Cycle: 1:1

Medium: 1900 Brain ($\sigma = 1.46$ mho/m, $\epsilon_r = 39.10$, $\rho = 1000$ kg/m³)

Phantom section: Flat Section; Space: 1.0 cm

Test Date: 01-10-2006; Ambient Temp: 23.6°C; Tissue Temp: 21.7°C

Probe: EX3DV4 - SN3561; ConvF(7.04, 7.04, 7.04); Calibrated: 8/24/2005

Sensor-Surface: 3mm (Mechanical Surface Detection)

Electronics: DAE4 Sn649; Calibrated: 9/13/2005

Phantom: SAM Sub; Type: SAM 4.0; Serial: TP:1357

Measurement SW: DASY4, V4.6 Build 19; Postprocessing SW: SEMCAD, V1.8 Build 159

1900MHz Dipole Validation

Area Scan (5x7x1): Measurement grid: dx=15mm, dy=15mm

Zoom Scan (5x5x7)/Cube 0: Measurement grid: dx=8mm, dy=8mm, dz=5mm

Input Power = 20.0 dBm (100 mW)

SAR(1 g) = 4.14 mW/g; SAR(10 g) = 2.28 mW/g

Target SAR(1g) = 3.97 mW/g; Deviation = +4.28 %

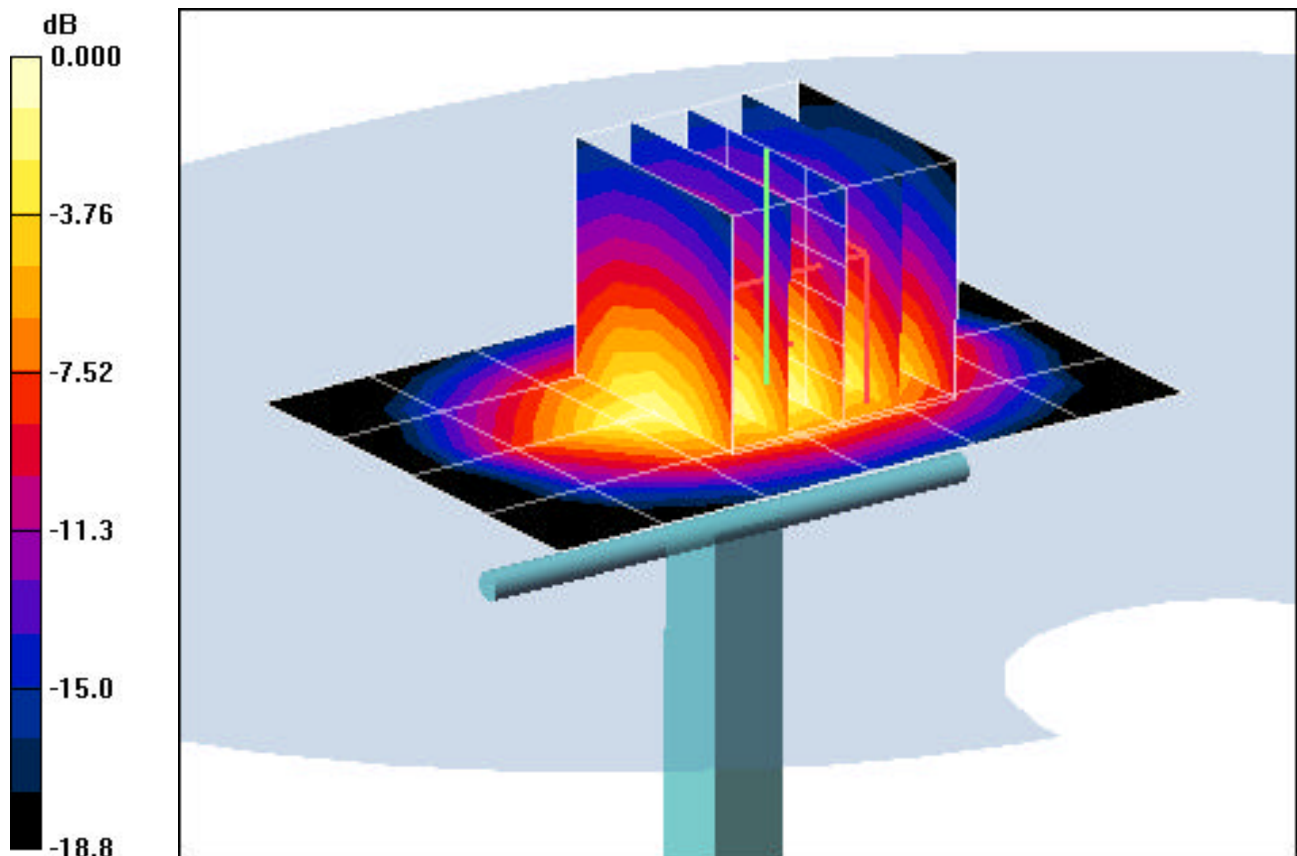

0 dB = 5.19mW/g

PCTEST ENGINEERING LABORATORY, INC.

DUT: Dipole 5200 MHz; Type: D5GHzV2; Serial: 1007

Communication System: CW; Frequency: 5200 MHz; Duty Cycle: 1:1

Medium: 5300 Brain ($\sigma = 4.73$ mho/m, $\epsilon_r = 36.20$, $\rho = 1000$ kg/m³)

Phantom section: Flat Section; Space: 1.0 cm

Test Date: 01-11-2006; Ambient Temp: 23.5°C; Tissue Temp: 21.5°C

Probe: EX3DV4 - SN3561; ConvF(4.26, 4.26, 4.26); Calibrated: 8/24/2005

Sensor-Surface: 3mm (Mechanical Surface Detection)

Electronics: DAE4 Sn649; Calibrated: 9/13/2005

Phantom: SAM Main; Type: SAM 4.0; Serial: TP:1197

Measurement SW: DASY4, V4.6 Build 19; Postprocessing SW: SEMCAD, V1.8 Build 159

5200MHz Dipole Validation

Area Scan (7x9x1): Measurement grid: dx=10mm, dy=10mm

Zoom Scan (8x8x8)/Cube 0: Measurement grid: dx=4.3mm, dy=4.3mm, dz=3mm

Input Power = 14.0 dBm (25 mW)

SAR(1 g) = 2.26 mW/g; SAR(10 g) = 0.642 mW/g

Target SAR(1g) = 2.17 mW/g; Deviation = +4.14%

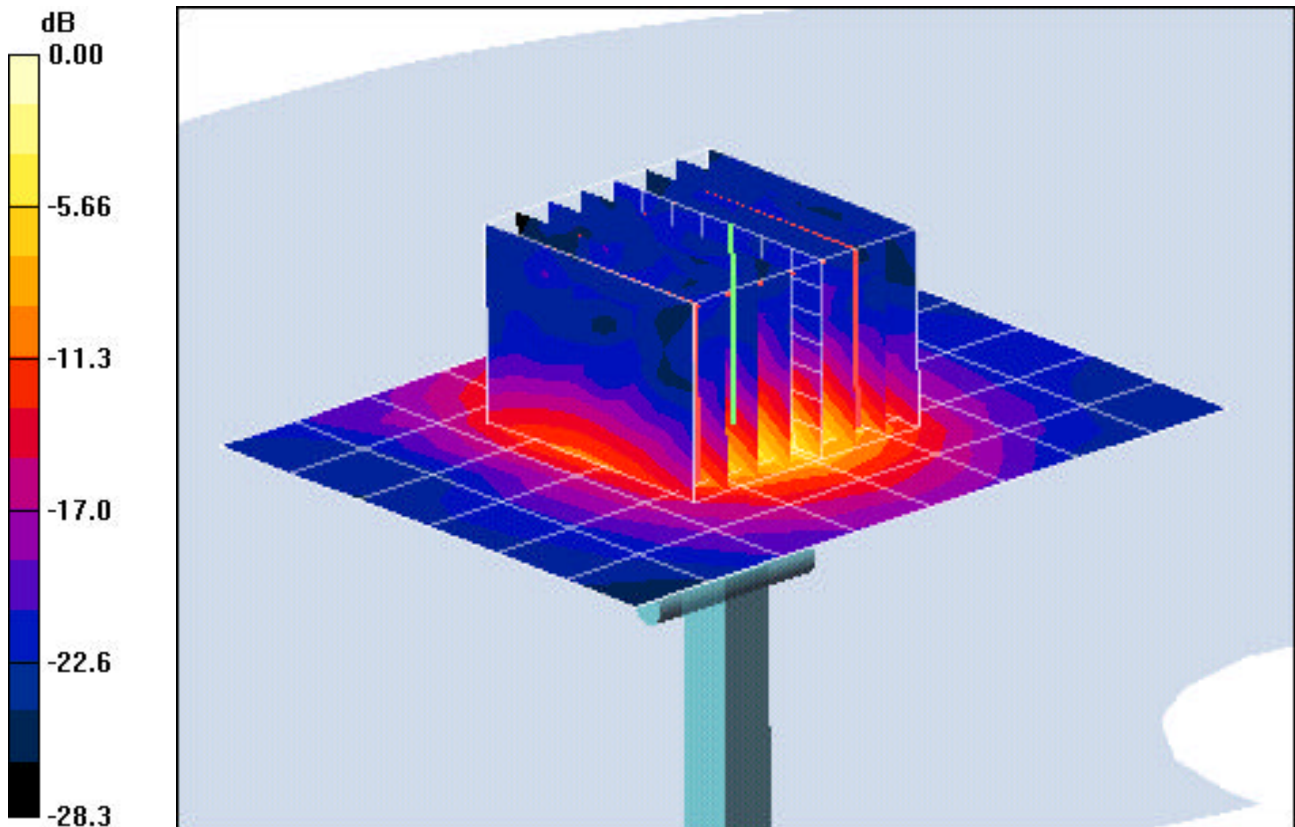

0 dB = 3.39mW/g

PCTEST ENGINEERING LABORATORY, INC.

DUT: Dipole 5800 MHz; Type: D5GHzV2; SN: 1007

Communication System: CW; Frequency: 5800 MHz; Duty Cycle: 1:1

Medium: 5800 Brain ($\sigma = 5.38$ mho/m, $\epsilon_r = 34.81$, $\rho = 1000$ kg/m³)

Phantom section: Flat Section

Test Date: 01-12-2006; Ambient Temp: 23.4°C; Tissue Temp: 21.5°C

Probe: EX3DV4 - SN3561; ConvF(3.75, 3.75, 3.75); Calibrated: 8/24/2005

Sensor-Surface: 3mm (Mechanical Surface Detection)

Electronics: DAE4 Sn649; Calibrated: 9/13/2005

Phantom: SAM Main; Type: SAM 4.0; Serial: TP:1197

Measurement SW: DASY4, V4.6 Build 19; Postprocessing SW: SEMCAD, V1.8 Build 159

5800MHz Dipole Validation

Area Scan (7x9x1): Measurement grid: dx=10mm, dy=10mm

Zoom Scan (8x8x8)/Cube 0: Measurement grid: dx=4.3mm, dy=4.3mm, dz=3mm

Input Power = 14.0 dBm (25mW)

SAR (1g) = 2.36 mW/g; SAR (10g) = 0.653 mW/g

Target SAR(1 g) = 2.25 mW/g; Deviation = +4.88%

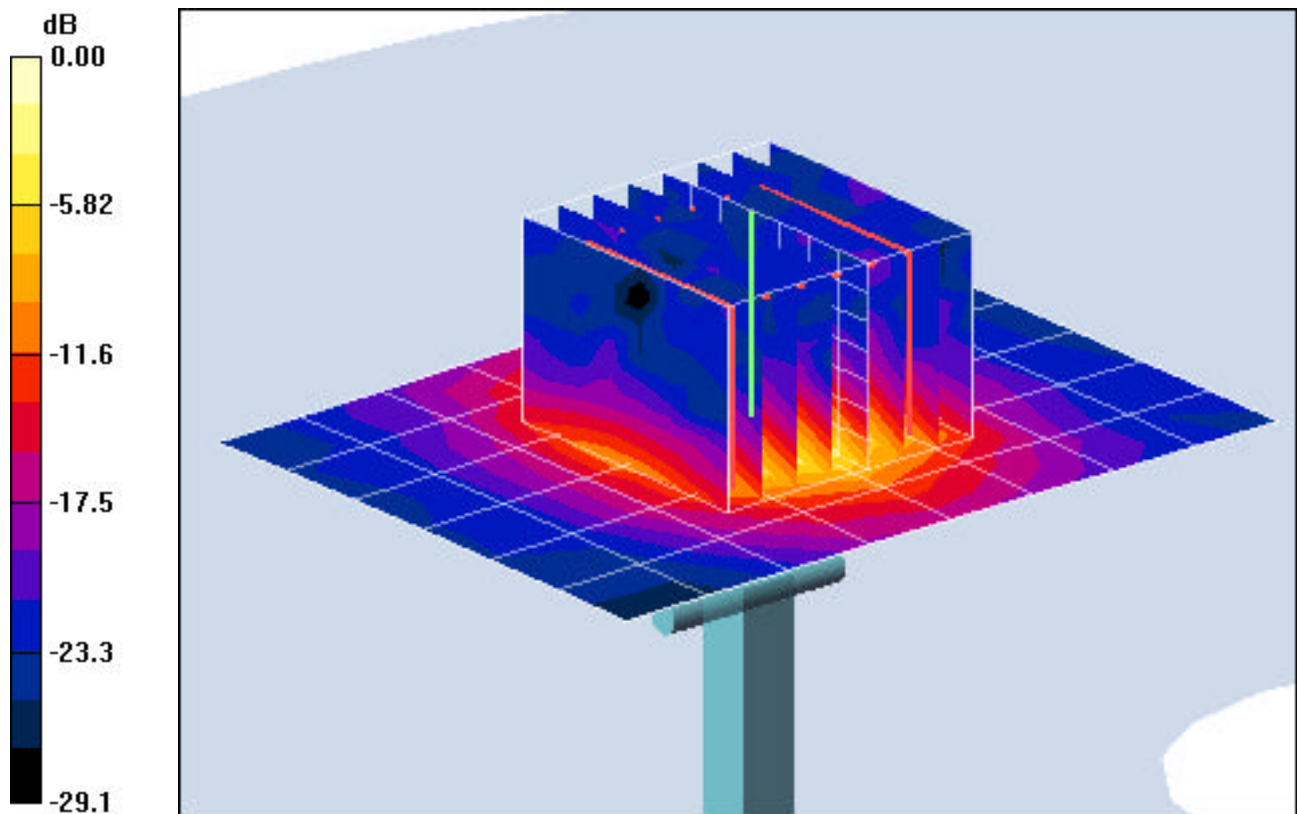

0 dB = 3.48mW/g

APPENDIX C: PROBE CALIBRATION



Accredited by the Swiss Federal Office of Metrology and Accreditation
The Swiss Accreditation Service is one of the signatories to the EA
Multilateral Agreement for the recognition of calibration certificates

Accreditation No.: **SCS 108**

Client **PC Test**

Certificate No: **EX3-3561_Aug05**

CALIBRATION CERTIFICATE

Object **EX3DV4 - SN:3561**

Calibration procedure(s) **QA CAL-01 v5 and QA CAL-14 v2
Calibration procedure for dosimetric E-field probes**

Calibration date: **August 24, 2005**

Condition of the calibrated item **In Tolerance**

This calibration certificate documents the traceability to national standards, which realize the physical units of measurements (SI).
The measurements and the uncertainties with confidence probability are given on the following pages and are part of the certificate.

All calibrations have been conducted in the closed laboratory facility: environment temperature (22 ± 3)°C and humidity < 70%.

Calibration Equipment used (M&TE critical for calibration)

Primary Standards	ID #	Cal Date (Calibrated by, Certificate No.)	Scheduled Calibration
Power meter E4419B	GB41293874	3-May-05 (METAS, No. 251-00466)	May-06
Power sensor E4412A	MY41495277	3-May-05 (METAS, No. 251-00466)	May-06
Power sensor E4412A	MY41498087	3-May-05 (METAS, No. 251-00466)	May-06
Reference 3 dB Attenuator	SN: S5054 (3c)	11-Aug-05 (METAS, No. 251-00499)	Aug-06
Reference 20 dB Attenuator	SN: S5086 (20b)	3-May-05 (METAS, No. 251-00467)	May-06
Reference 30 dB Attenuator	SN: S5129 (30b)	11-Aug-05 (METAS, No. 251-00500)	Aug-06
Reference Probe ES3DV2	SN: 3013	7-Jan-05 (SPEAG, No. ES3-3013_Jan05)	Jan-06
DAE4	SN: 654	29-Nov-04 (SPEAG, No. DAE4-654_Nov04)	Nov-05

Secondary Standards	ID #	Check Date (in house)	Scheduled Check
RF generator HP 8648C	US3642U01700	4-Aug-99 (SPEAG, in house check Dec-03)	In house check: Dec-05
Network Analyzer HP 8753E	US37390585	18-Oct-01 (SPEAG, in house check Nov-04)	In house check: Nov 05

Calibrated by: **Katja Pokovic** (Name) **Technical Manager** (Function)  (Signature)

Approved by: **Niels Kuster** (Name) **Quality Manager** (Function)  (Signature)

Issued: August 24, 2005

This calibration certificate shall not be reproduced except in full without written approval of the laboratory.



Accredited by the Swiss Federal Office of Metrology and Accreditation
The Swiss Accreditation Service is one of the signatories to the EA
Multilateral Agreement for the recognition of calibration certificates

Accreditation No.: **SCS 108**

Glossary:

TSL	tissue simulating liquid
NORM _{x,y,z}	sensitivity in free space
ConF	sensitivity in TSL / NORM _{x,y,z}
DCP	diode compression point
Polarization φ	φ rotation around probe axis
Polarization ϑ	ϑ rotation around an axis that is in the plane normal to probe axis (at measurement center), i.e., $\vartheta = 0$ is normal to probe axis

Calibration is Performed According to the Following Standards:

- IEEE Std 1528-2003, "IEEE Recommended Practice for Determining the Peak Spatial-Averaged Specific Absorption Rate (SAR) in the Human Head from Wireless Communications Devices: Measurement Techniques", December 2003
- CENELEC EN 50361, "Basic standard for the measurement of Specific Absorption Rate related to human exposure to electromagnetic fields from mobile phones (300 MHz - 3 GHz), July 2001

Methods Applied and Interpretation of Parameters:

- NORM_{x,y,z}**: Assessed for E-field polarization $\vartheta = 0$ ($f \leq 900$ MHz in TEM-cell; $f > 1800$ MHz: R22 waveguide). NORM_{x,y,z} are only intermediate values, i.e., the uncertainties of NORM_{x,y,z} does not effect the E²-field uncertainty inside TSL (see below *ConvF*).
- NORM(f)_{x,y,z}** = NORM_{x,y,z} * *frequency_response* (see Frequency Response Chart). This linearization is implemented in DASY4 software versions later than 4.2. The uncertainty of the frequency response is included in the stated uncertainty of *ConvF*.
- DCP_{x,y,z}**: DCP are numerical linearization parameters assessed based on the data of power sweep (no uncertainty required). DCP does not depend on frequency nor media.
- ConvF and Boundary Effect Parameters**: Assessed in flat phantom using E-field (or Temperature Transfer Standard for $f \leq 800$ MHz) and inside waveguide using analytical field distributions based on power measurements for $f > 800$ MHz. The same setups are used for assessment of the parameters applied for boundary compensation (alpha, depth) of which typical uncertainty values are given. These parameters are used in DASY4 software to improve probe accuracy close to the boundary. The sensitivity in TSL corresponds to NORM_{x,y,z} * *ConvF* whereby the uncertainty corresponds to that given for *ConvF*. A frequency dependent *ConvF* is used in DASY version 4.4 and higher which allows extending the validity from ± 50 MHz to ± 100 MHz.
- Spherical isotropy (3D deviation from isotropy)**: in a field of low gradients realized using a flat phantom exposed by a patch antenna.
- Sensor Offset**: The sensor offset corresponds to the offset of virtual measurement center from the probe tip (on probe axis). No tolerance required.

Probe EX3DV4

SN:3561

Manufactured:	February 14, 2005
Calibrated:	August 24, 2005

Calibrated for DASY Systems

(Note: non-compatible with DASY2 system!)

DASY - Parameters of Probe: EX3DV4 SN:3561

Sensitivity in Free Space^A

NormX	0.430 ± 10.1%	$\mu\text{V}/(\text{V}/\text{m})^2$	DCP X	90 mV
NormY	0.470 ± 10.1%	$\mu\text{V}/(\text{V}/\text{m})^2$	DCP Y	90 mV
NormZ	0.430 ± 10.1%	$\mu\text{V}/(\text{V}/\text{m})^2$	DCP Z	90 mV

Diode Compression^B

Sensitivity in Tissue Simulating Liquid (Conversion Factors)

Please see Page 8.

Boundary Effect

TSL **900 MHz** **Typical SAR gradient: 5 % per mm**

Sensor Center to Phantom Surface Distance		2.0 mm	3.0 mm
SAR _{be} [%]	Without Correction Algorithm	3.8	1.5
SAR _{be} [%]	With Correction Algorithm	0.0	0.0

TSL **1810 MHz** **Typical SAR gradient: 10 % per mm**

Sensor Center to Phantom Surface Distance		2.0 mm	3.0 mm
SAR _{be} [%]	Without Correction Algorithm	4.7	2.8
SAR _{be} [%]	With Correction Algorithm	1.1	0.8

Sensor Offset

Probe Tip to Sensor Center **1.0 mm**

The reported uncertainty of measurement is stated as the standard uncertainty of measurement multiplied by the coverage factor k=2, which for a normal distribution corresponds to a coverage probability of approximately 95%.

^A The uncertainties of NormX,Y,Z do not affect the E²-field uncertainty inside TSL (see Page 8).

^B Numerical linearization parameter: uncertainty not required.

Frequency Response of E-Field

(TEM-Cell:ifi110 EXX, Waveguide: R22)

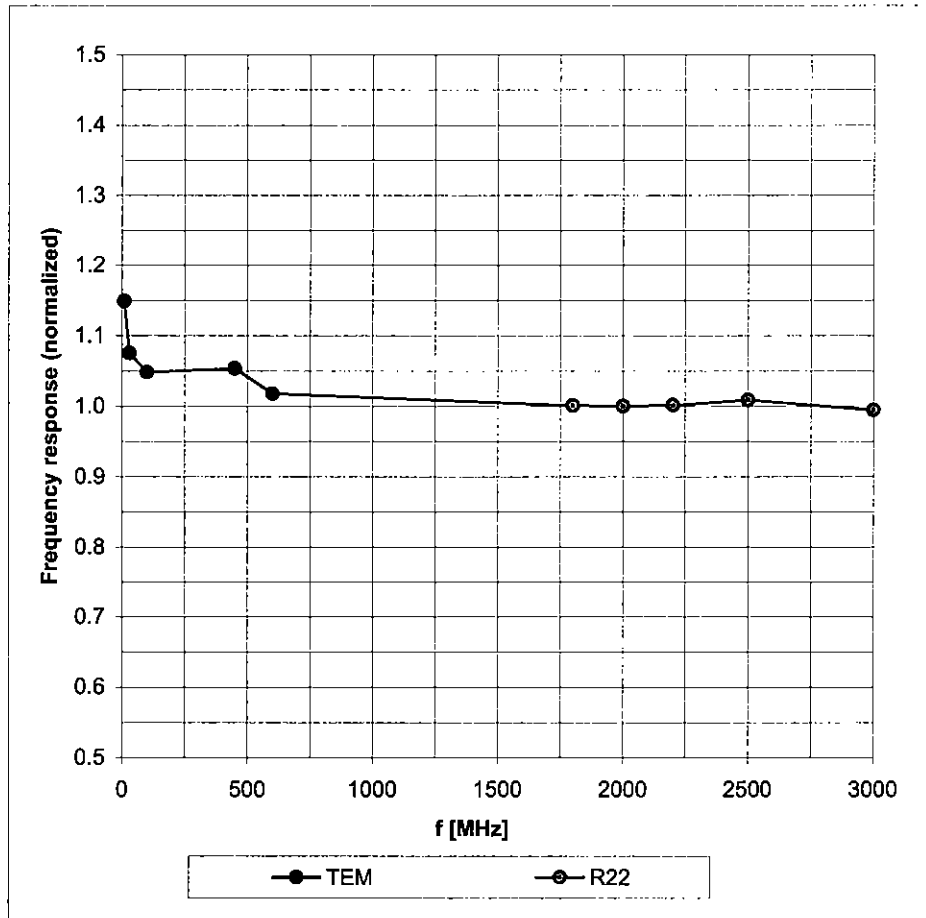

Uncertainty of Frequency Response of E-field: $\pm 6.3\%$ (k=2)

Receiving Pattern (ϕ), $\vartheta = 0^\circ$

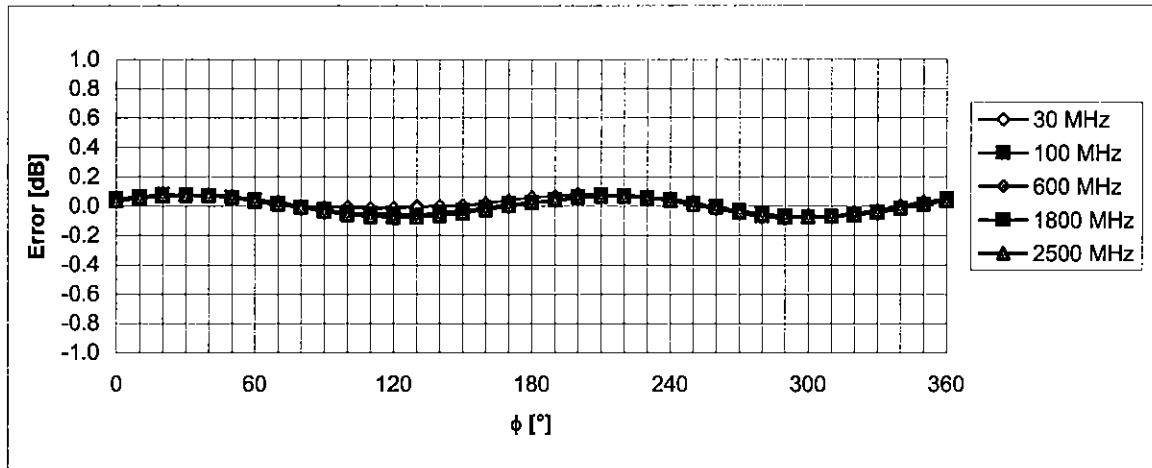
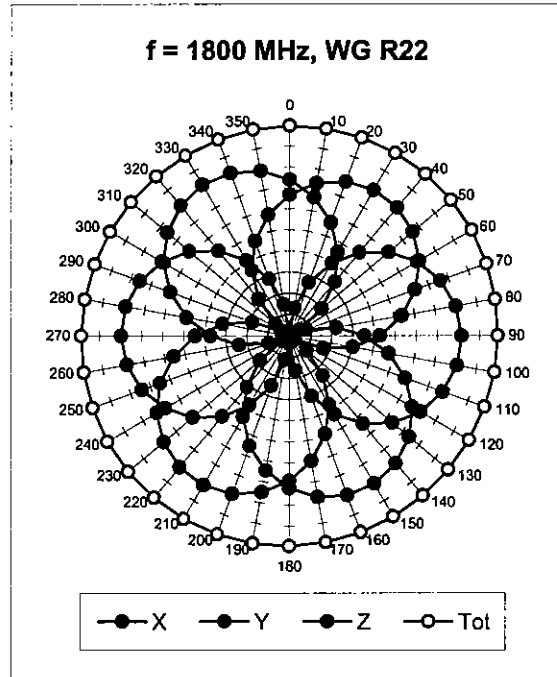
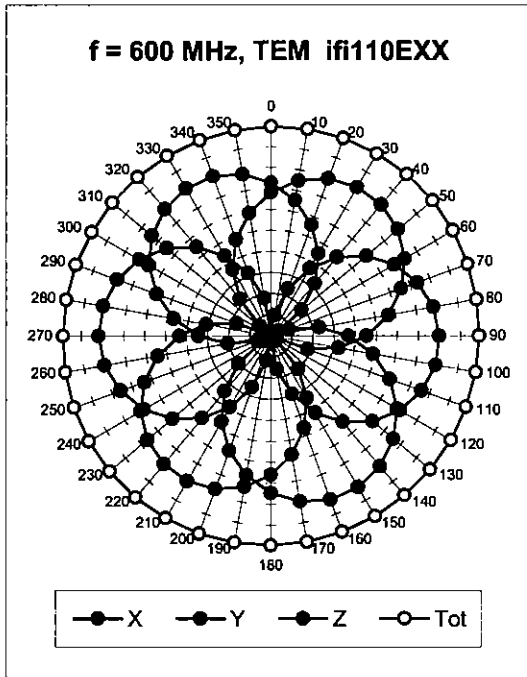

Uncertainty of Axial Isotropy Assessment: $\pm 0.5\%$ ($k=2$)

Dynamic Range $f(\text{SAR}_{\text{head}})$ (Waveguide R22, $f = 1800 \text{ MHz}$)

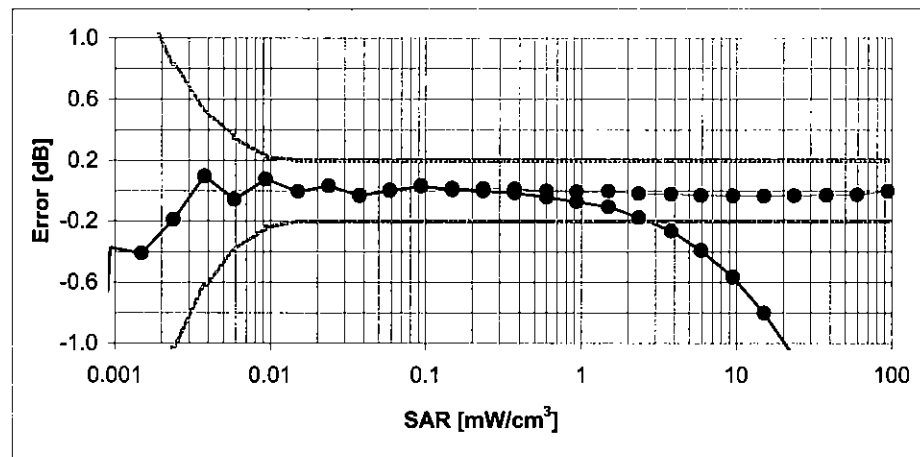
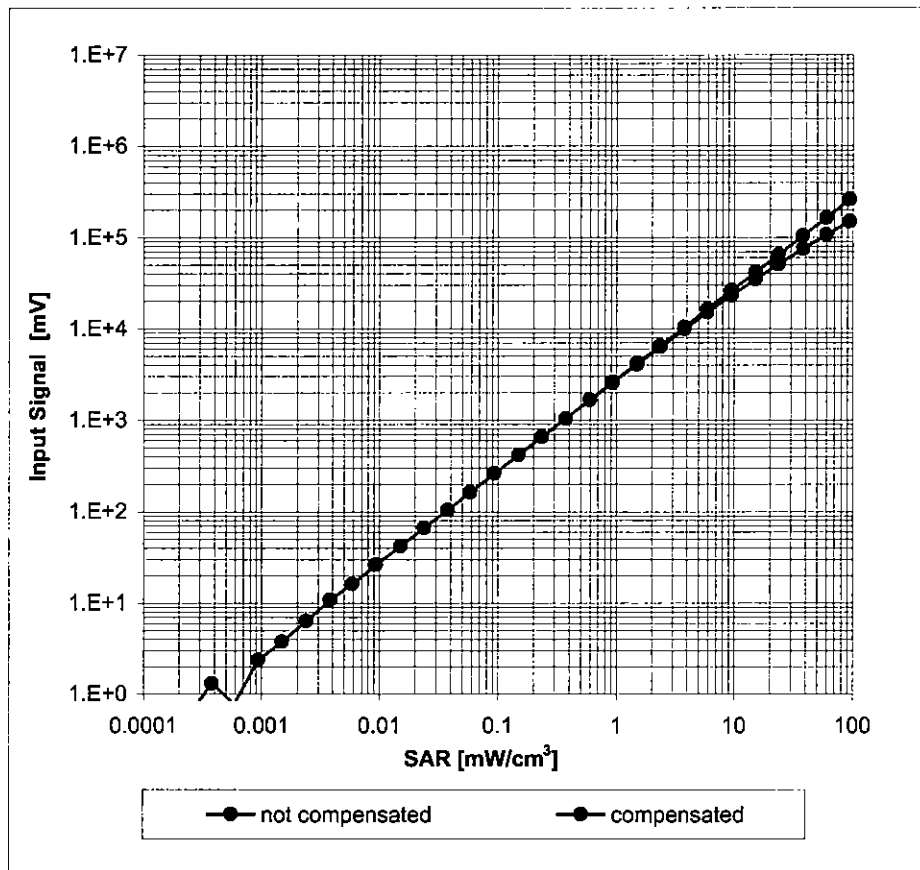

Uncertainty of Linearity Assessment: $\pm 0.6\%$ ($k=2$)

Conversion Factor Assessment

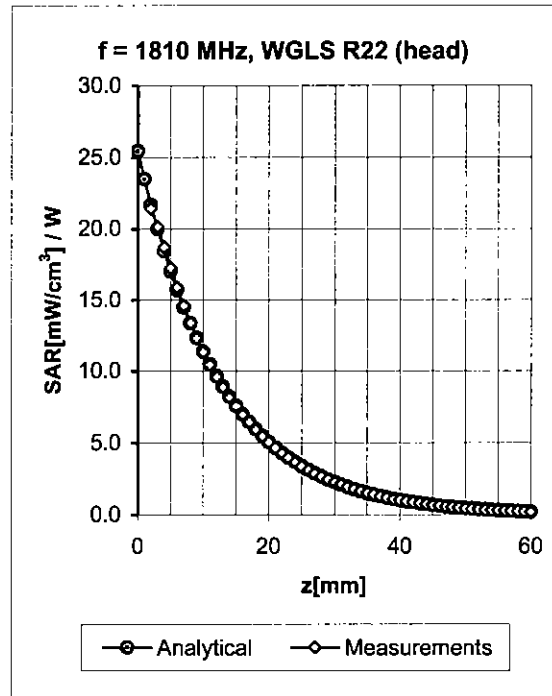
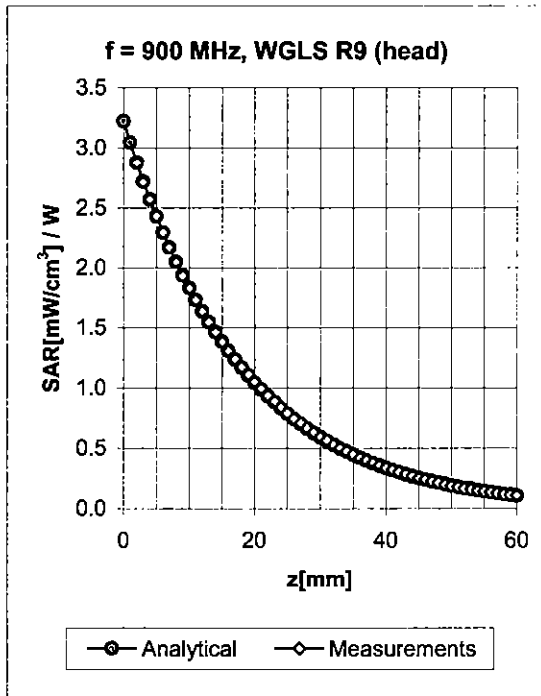

f [MHz]	Validity [MHz] ^c	TSL	Permittivity	Conductivity	Alpha	Depth	ConvF Uncertainty
900	± 50 / ± 100	Head	41.5 ± 5%	0.97 ± 5%	0.21	1.13	7.91 ± 11.0% (k=2)
1810	± 50 / ± 100	Head	40.0 ± 5%	1.40 ± 5%	0.47	0.94	7.04 ± 11.0% (k=2)
2450	± 50 / ± 100	Head	39.2 ± 5%	1.80 ± 5%	0.61	0.71	6.37 ± 11.8% (k=2)
900	± 50 / ± 100	Body	55.0 ± 5%	1.05 ± 5%	0.32	0.93	7.90 ± 11.0% (k=2)
1810	± 50 / ± 100	Body	53.3 ± 5%	1.52 ± 5%	0.34	1.60	6.48 ± 11.0% (k=2)
2450	± 50 / ± 100	Body	52.7 ± 5%	1.95 ± 5%	0.75	0.62	6.30 ± 11.8% (k=2)

^c The validity of ± 100 MHz only applies for DASY v4.4 and higher (see Page 2). The uncertainty is the RSS of the ConvF uncertainty at calibration frequency and the uncertainty for the indicated frequency band.

Deviation from Isotropy in HSL

Error (ϕ , θ), $f = 900$ MHz

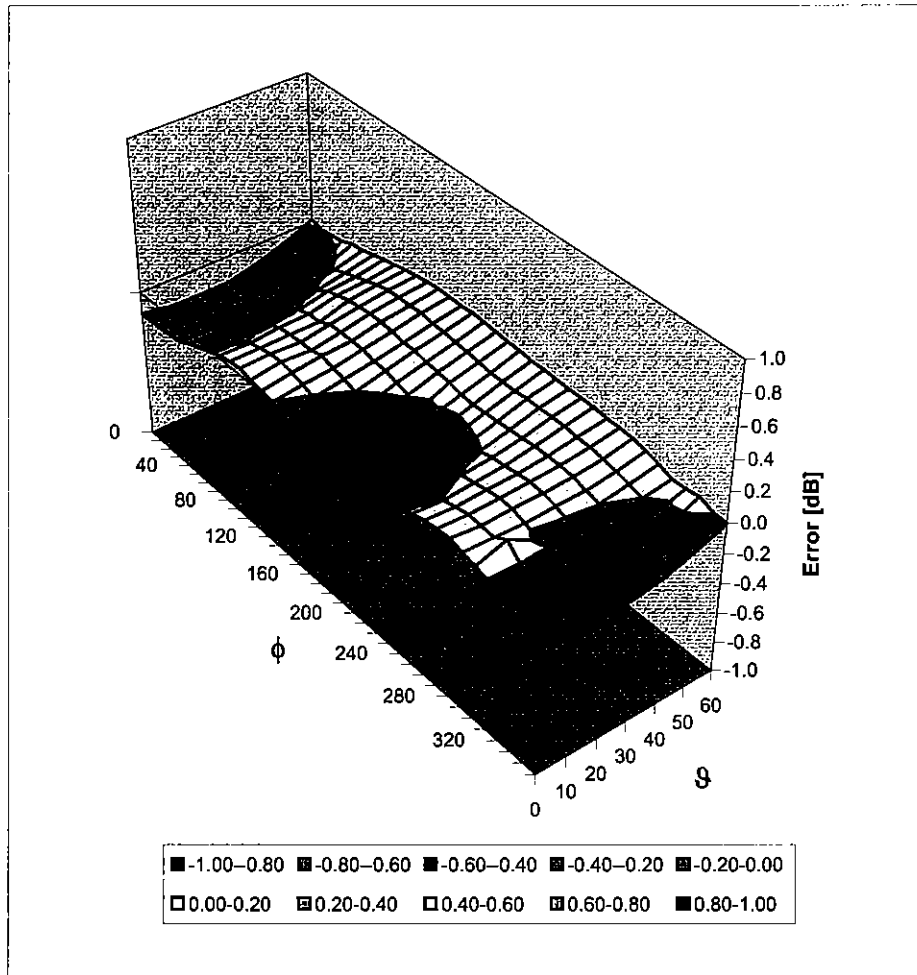

Uncertainty of Spherical Isotropy Assessment: $\pm 2.6\%$ ($k=2$)

Appendix^D

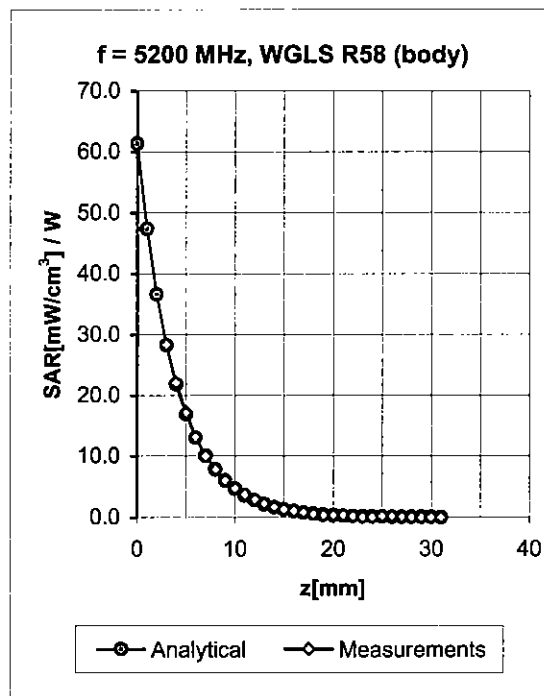
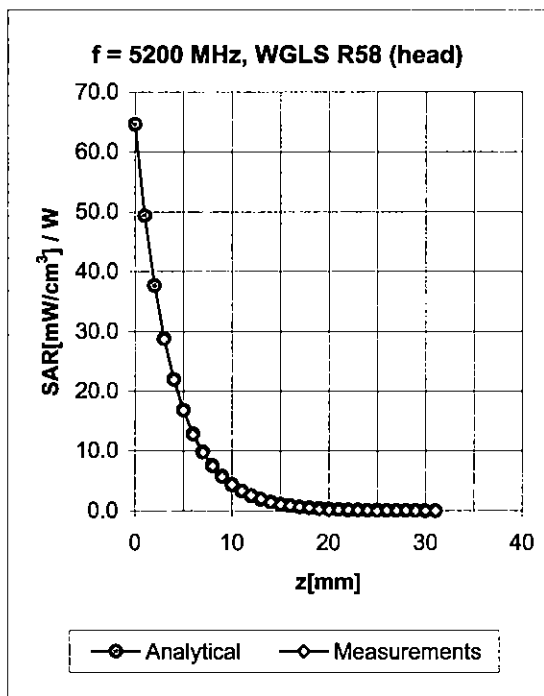

f [MHz] ^D	Validity [MHz]	TSL	Permittivity	Conductivity	Alpha	Depth	ConvF Uncertainty
5200	± 50	Head	36.0 ± 5%	4.76 ± 5%	0.49	1.36	4.26 ± 13.6% (k=2)
5800	± 50	Head	35.3 ± 5%	5.27 ± 5%	0.52	1.42	3.75 ± 13.6% (k=2)
5200	± 50	Body	49.0 ± 5%	5.30 ± 5%	0.50	1.63	4.10 ± 13.6% (k=2)
5800	± 50	Body	48.2 ± 5%	6.00 ± 5%	0.49	1.70	3.63 ± 13.6% (k=2)

^D Accreditation for ConvF assessment above 3000 MHz is currently applied for.