



FCC CFR47 PART 15 SUBPART C

CERTIFICATION TEST REPORT

FOR

Bluetooth Module

MODEL NUMBER: BT12B

FCC ID: ACJ9TGBT12B

REPORT NUMBER: 32KE0147-HO-B-R1

ISSUE DATE: July 23, 2012

Prepared for

**Panasonic Corporation of North America
One Panasonic Way, 4B-8
Secaucus, New Jersey, 07094, USA**

Prepared by

**UL Japan, Inc.
Head Office EMC Lab.
4383-326 Asama-cho, Ise-shi, Mie-ken
516-0021 JAPAN
TEL: +81 596 24 8116
FAX: +81 596 24 8124**



NVLAP LAB CODE: 200572-0

This laboratory is accredited by the NVLAP LAB CODE 200572-0, U.S.A. The tests reported herein have been performed in accordance with its terms of accreditation.

*As for the range of Accreditation in NVLAP, you may refer to the WEB address, <http://www.ul.com/japan/jpn/pages/services/emc/about/mark1/index.jsp#nvlap>

Revision History

Rev.	Issue Date	Revisions	Revised By
--	07/17/12	Initial Issue	-----
1	07/23/12	Addition of Antenna Type (PIFA) in clause 5.3 *This report is a revised version of 32KE0147-HO-B, which is replaced with this report.	T. Hatakeda

TABLE OF CONTENTS

1. ATTESTATION OF TEST RESULTS	4
2. TEST METHODOLOGY	5
3. FACILITIES AND ACCREDITATION	5
4. CALIBRATION AND UNCERTAINTY	5
4.1. <i>MEASURING INSTRUMENT CALIBRATION.....</i>	<i>5</i>
4.2. <i>SAMPLE CALCULATION.....</i>	<i>5</i>
4.3. <i>MEASUREMENT UNCERTAINTY.....</i>	<i>6</i>
5. EQUIPMENT UNDER TEST	7
5.1. <i>DESCRIPTION OF EUT.....</i>	<i>7</i>
5.2. <i>MAXIMUM OUTPUT POWER.....</i>	<i>7</i>
5.3. <i>DESCRIPTION OF AVAILABLE ANTENNAS.....</i>	<i>7</i>
5.4. <i>SOFTWARE AND FIRMWARE</i>	<i>7</i>
5.5. <i>WORST-CASE CONFIGURATIONS AND MODE</i>	<i>7</i>
5.6. <i>DESCRIPTION OF TEST SETUP</i>	<i>8</i>
6. ANTENNA PORT TEST RESULTS.....	11
6.1. <i>Bluetooth Low Energy (LE) MODE</i>	<i>11</i>
6.1.1. <i>6dB BANDWIDTH.....</i>	<i>11</i>
6.1.2. <i>99% BANDWIDTH.....</i>	<i>13</i>
6.1.3. <i>MAXIMUM PEAK OUTPUT POWER</i>	<i>15</i>
6.1.4. <i>AVERAGE POWER.....</i>	<i>16</i>
6.1.5. <i>POWER SPECTRAL DENSITY</i>	<i>17</i>
6.1.6. <i>CONDUCTED SPURIOUS EMISSIONS.....</i>	<i>19</i>
7. RADIATED TEST RESULTS.....	28
7.1. <i>LIMITS AND PROCEDURE.....</i>	<i>28</i>
8. AC POWER LINE CONDUCTED EMISSIONS.....	32
9. MAXIMUM PERMISSIBLE EXPOSURE.....	35
10. SETUP PHOTOS.....	39

1. ATTESTATION OF TEST RESULTS

COMPANY NAME: Panasonic Corporation of North America
One Panasonic Way, 4B-8
Secaucus, New Jersey, 07094, USA

EUT DESCRIPTION: Bluetooth Module

MODEL: BT12B

SERIAL NUMBER: DVT1 (Conducted sample)
DVT2 (Radiated sample)

DATE TESTED: June 20 to 30, 2012

APPLICABLE STANDARDS	
STANDARD	TEST RESULTS
CFR 47 Part 15 Subpart C	Pass

UL Japan, Inc. tested the above equipment in accordance with the requirements set forth in the above standards. All indications of Pass/Fail in this report are opinions expressed by UL Japan, Inc based on interpretations and/or observations of test results. The test results show that the equipment tested is capable of demonstrating compliance with the requirements as documented in this report.

Note: The results documented in this report apply only to the tested sample, under the conditions and modes of operation as described herein. This document may not be altered or revised in any way unless done so by UL Japan, Inc. and all revisions are duly noted in the revisions section. Any alteration of this document not carried out by UL Japan, Inc. will constitute fraud and shall nullify the document. No part of this report may be used to claim product certification, approval, or endorsement by any government agency.

Approved & Released For UL Japan, Inc. By:

Tested By:



Takahiro Hatakeda
Leader of WiSE Japan
UL Verification Services
UL Japan, Inc.

Yutaka Yoshida
Engineer of WiSE Japan
UL Verification Services
UL Japan, Inc.

2. TEST METHODOLOGY

The tests documented in this report were performed in accordance with ANSI C63.10-2009, FCC CFR 47 Part 2, FCC CFR 47 Part 15.

3. FACILITIES AND ACCREDITATION

The test sites and measurement facilities used to collect data are located at 4383-326 Asama-cho, Ise-shi, Mie-ken 516-0021 JAPAN.

UL Japan, Inc. is accredited by NVLAP, Laboratory Code 200572-0
The full scope of accreditation can be viewed at
<http://www.ul.com/japan/jpn/pages/services/emc/about/mark1/index.jsp#nvlap>

4. CALIBRATION AND UNCERTAINTY

4.1. MEASURING INSTRUMENT CALIBRATION

The measuring equipment utilized to perform the tests documented in this report has been calibrated in accordance with the manufacturer's recommendations, and is traceable to recognized national standards.

4.2. SAMPLE CALCULATION

Where relevant, the following sample calculation is provided:

$$\begin{aligned} \text{Field Strength (dBuV/m)} &= \text{Measured Voltage (dBuV)} + \text{Antenna Factor} \\ & \text{(dB/m)} + \text{Cable Loss (dB)} - \text{Preamp Gain (dB)} \\ 36.5 \text{ dBuV} + 18.7 \text{ dB/m} + 0.6 \text{ dB} - 26.9 \text{ dB} &= 28.9 \text{ dBuV/m} \end{aligned}$$

4.3. MEASUREMENT UNCERTAINTY

Where relevant, the following measurement uncertainty levels have been estimated for tests performed on the apparatus:

EMI

The following uncertainties have been calculated to provide a confidence level of 95% using a coverage factor k=2.

Test room (semi-anechoic chamber)	Conducted emission (+dB)
	150kHz-30MHz
No.1	3.1dB
No.2	3.3dB
No.3	3.7dB
No.4	3.2dB

Test room (semi-anechoic chamber)	Radiated emission						
	(3m*)(+dB)			(1m*)(+dB)		(0.5m*)(+dB)	
	9kHz -30MHz	30MHz -300MHz	300MHz -1GHz	1GHz -10GHz	10GHz -18GHz	18GHz -26.5GHz	26.5GHz -40GHz
No.1	4.2dB	5.0dB	5.1dB	4.7dB	5.7dB	4.4dB	4.3dB
No.2	4.1dB	5.2dB	5.1dB	4.8dB	5.6dB	4.3dB	4.2dB
No.3	4.5dB	5.0dB	5.2dB	4.8dB	5.6dB	4.5dB	4.2dB
No.4	4.7dB	5.2dB	5.2dB	4.8dB	5.6dB	5.1dB	4.2dB

*3m/1m/0.5m = Measurement distance

Power meter (+dB)	
Below 1GHz	Above 1GHz
1.0dB	1.0dB

Antenna terminal conducted emission and Power density (+dB)			Antenna terminal conducted emission (+dB)		Channel power (+dB)
Below 1GHz	1GHz-3GHz	3GHz-18GHz	18GHz-26.5GHz	26.5GHz-40GHz	
1.0dB	1.1dB	2.7dB	3.2dB	3.3dB	1.5dB

5. EQUIPMENT UNDER TEST

5.1. DESCRIPTION OF EUT

The EUT is a Bluetooth Module, Model BT12B.

The radio module is manufactured by Panasonic.

5.2. MAXIMUM OUTPUT POWER

The transmitter has a maximum peak conducted output power as follows:

Frequency Range (MHz)	Mode	Output Power (dBm)	Output Power (mW)
2402-2480	Bluetooth Low Energy(LE)	1.55	1.43

5.3. DESCRIPTION OF AVAILABLE ANTENNAS

The radio utilizes a PIFA antenna with a maximum gain of -0.48dBi.

5.4. SOFTWARE AND FIRMWARE

The EUT driver software installed during testing was ALPS module with CSR BlueCore08 Bluetooth, v2.4.0.0.

The test utility software used during testing was CSR BtCLI, v2.4.

5.5. WORST-CASE CONFIGURATIONS AND MODE

The worst-case data rate for each mode is determined to be as follows, based on preliminary tests of the chipset utilized in this radio.

All final tests in the LE mode were made at 1 Mb/s.

The EUT was investigated in three different positions, X, Y, & Z and turned out the X (Horizontal), X (Vertical) were worst-position for Module and the X (Horizontal), Y (Vertical) for Antenna. This worst position will be set for all radiated emissions testing.

5.6. DESCRIPTION OF TEST SETUP

SUPPORT EQUIPMENT

PERIPHERAL SUPPORT EQUIPMENT LIST				
Description	Manufacturer	Model	Serial Number	FCC ID
Laptop PC	Panasonic	CF-SX2J03YS	2SKSA00563	DoC
AC Adaptor	Panasonic	CF-AA6503A M4	6503AM412213669	N/A

I/O CABLES

Cable No.	Port	# of Identical Ports	Connector Type	Cable Type	Cable Length (m)	Remarks
1	I/O	1	I/O	Unshielded	0.1	
2	DC	1	USB	Unshielded	1.3	*1)
3	AC	1	DC	Unshielded	1.8	

*1) It was confirmed that the ferrite core did not affect the emission test result

TEST SETUP

The EUT is configured as shown in the setup diagram.

SETUP DIAGRAM

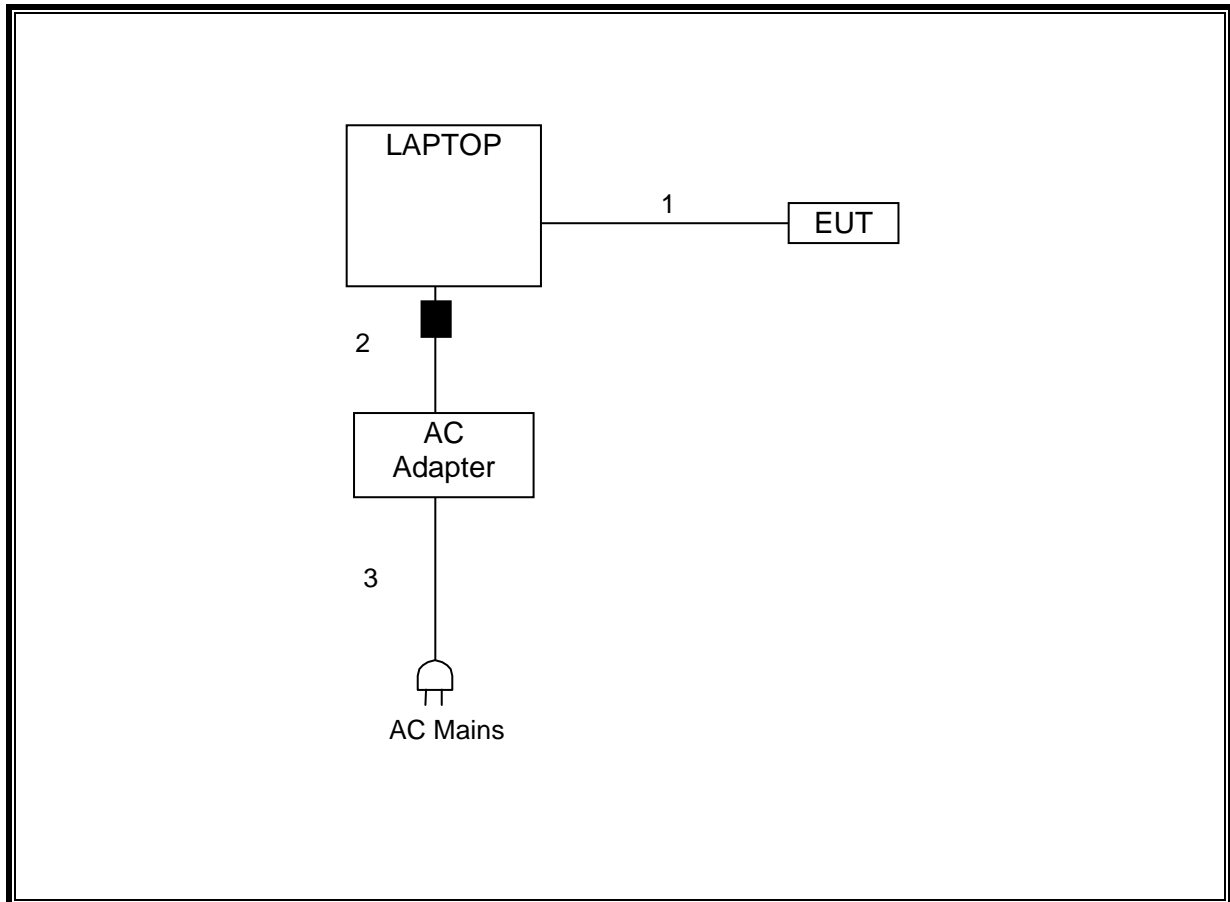

TEST AND MEASUREMENT EQUIPMENT

The following test and measurement equipment was utilized for the tests documented in this report:

Control No.	Instrument	Manufacturer	Model No	Serial No	Test Item	Calibration Date * Interval(month)
MSA-03	Spectrum Analyzer	Agilent	E4448A	MY44020357	AT	2011/11/23 * 12
MPM-08	Power Meter	Anritsu	ML2495A	6K00003338	AT	2011/09/13 * 12
MPSE-11	Power sensor	Anritsu	MA2411B	011737	AT	2011/09/13 * 12
MCC-138	Microwave cable	HUBER+SUHNER	SUCOFLEX 102	37953/2	AT	2011/10/28 * 12
MCC-102	Microwave Cable	Hirose Electric	U.FL-2LP-066J1-A(200)	-	AT	2012/06/27 * 12
MAT-19	Attenuator(6dB)(above 1GHz)	HIROSE ELECTRIC CO.,LTD.	AT-106	-	AT	2012/01/12 * 12
MOS-14	Thermo-Hygrometer	Custom	CTH-201	-	AT	2012/02/06 * 12
MAEC-04	Semi Anechoic Chamber(NSA)	TDK	Semi Anechoic Chamber 3m	DA-10005	RE/CE	2012/02/29 * 12
MOS-15	Thermo-Hygrometer	Custom	CTH-180	-	RE/CE	2012/02/06 * 12
MJM-07	Measure	PROMART	SEN1955	-	RE/CE	-
COTS-MEMI	EMI measurement program	TSJ	TEPTO-DV	-	RE/CE	-
MSA-03	Spectrum Analyzer	Agilent	E4448A	MY44020357	RE	2011/11/23 * 12
MHA-21	Horn Antenna 1-18GHz	Schwarzbeck	BBHA9120D	9120D-557	RE	2011/08/11 * 12
MCC-141	Microwave Cable	Junkosha	MWX221	1203S212(1m) / 1204S062(5m)	RE	2012/04/23 * 12
MPA-12	MicroWave System Amplifier	Agilent	83017A	MY39500780	RE	2012/03/28 * 12
MHA-17	Horn Antenna 15-40GHz	Schwarzbeck	BBHA9170	BBHA9170307	RE	2012/06/27 * 12
MHF-06	High Pass Filter 3.5-24GHz	TOKIMEC	TF323DCA	601	RE	2012/05/30 * 12
MSA-05	Spectrum Analyzer	Advantest	R3273	160400285	RE/CE	2011/11/23 * 12
MTR-07	Test Receiver	Rohde & Schwarz	ESCI	100635	RE/CE	2012/04/05 * 12
MBA-05	Biconical Antenna	Schwarzbeck	BBA9106	1302	RE	2011/11/16 * 12
MLA-08	Logperiodic Antenna	Schwarzbeck	UKLP9140-A	N/A	RE	2011/11/16 * 12
MCC-50	Coaxial Cable	UL Japan	-	-	RE	2012/06/01 * 12
AT-38	Attenuator	Anritsu	MP721B	6200961025	RE	2011/12/08 * 12
MPA-14	Pre Amplifier	SONOMA INSTRUMENT	310	260833	RE	2012/03/05 * 12
MLS-06	LISN(AMN)	Schwarzbeck	NSLK8127	8127363	CE	2012/02/06 * 12
MTA-31	Terminator	TME	CT-01	-	CE	2012/01/11 * 12
MAT-67	Attenuator(13dB)	JFW Industries, Inc.	50FP-013H2 N	-	CE	2012/01/28 * 12
MCC-113	Coaxial cable	Fujikura/Suhner/TSJ	5D-2W(10m)/SFM141(5m)/421-010(1m)/suciform 141-PE(1m)/RFM-E121(Switcher)	-/04178	CE	2011/07/04 * 12

The expiration date of the calibration is the end of the expired month.

As for some calibrations performed after the tested dates, those test equipment have been controlled by means of an unbroken chains of calibrations.

All equipment is calibrated with valid calibrations. Each measurement data is traceable to the national or international standards.

Test Item:

RE: Radiated emission, CE: Conducted emission, AT: Antenna Terminal Conducted test

6. ANTENNA PORT TEST RESULTS

6.1. Bluetooth Low Energy (LE) MODE

6.1.1. 6dB BANDWIDTH

LIMITS

FCC §15.247 (a) (2)

IC RSS-210 A8.2 (a)

The minimum 6 dB bandwidth shall be at least 500 kHz.

TEST PROCEDURE

The transmitter output is connected to a spectrum analyzer. The RBW is set to 100 kHz and the VBW is set to 300 kHz. The sweep time is coupled.

RESULTS

Channel	Frequency (MHz)	6 dB Bandwidth (kHz)	Minimum Limit (kHz)
Low	2402	696.094	500
Middle	2440	694.765	500
High	2480	697.793	500

6dB BANDWIDTH

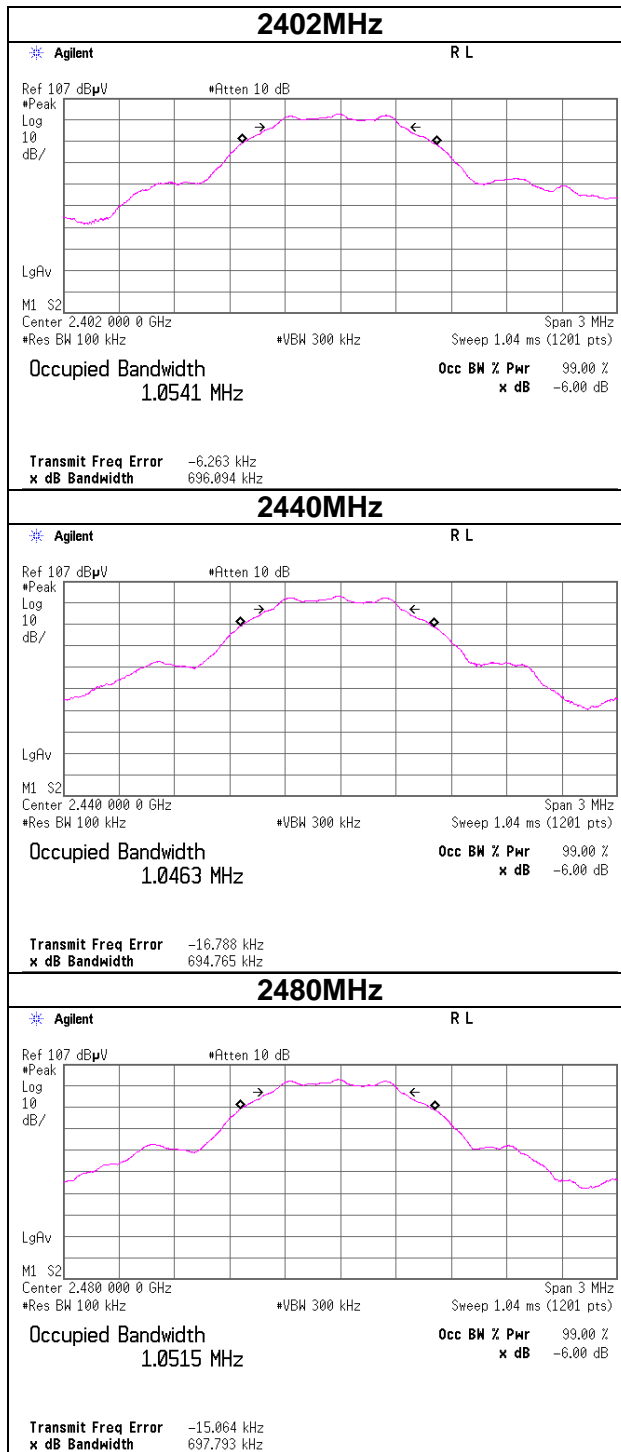

6.1.2. 99% BANDWIDTH

LIMITS

None; for reporting purposes only.

TEST PROCEDURE

The transmitter output is connected to the spectrum analyzer. The RBW is set to 1% to 3% of the 99 % bandwidth. The VBW is set to 3 times the RBW. The sweep time is coupled. The spectrum analyzer internal 99% bandwidth function is utilized.

RESULTS

Channel	Frequency (MHz)	99% Bandwidth (MHz)
Low	2402	1.0315
Middle	2440	1.0278
High	2480	1.0318

99% BANDWIDTH

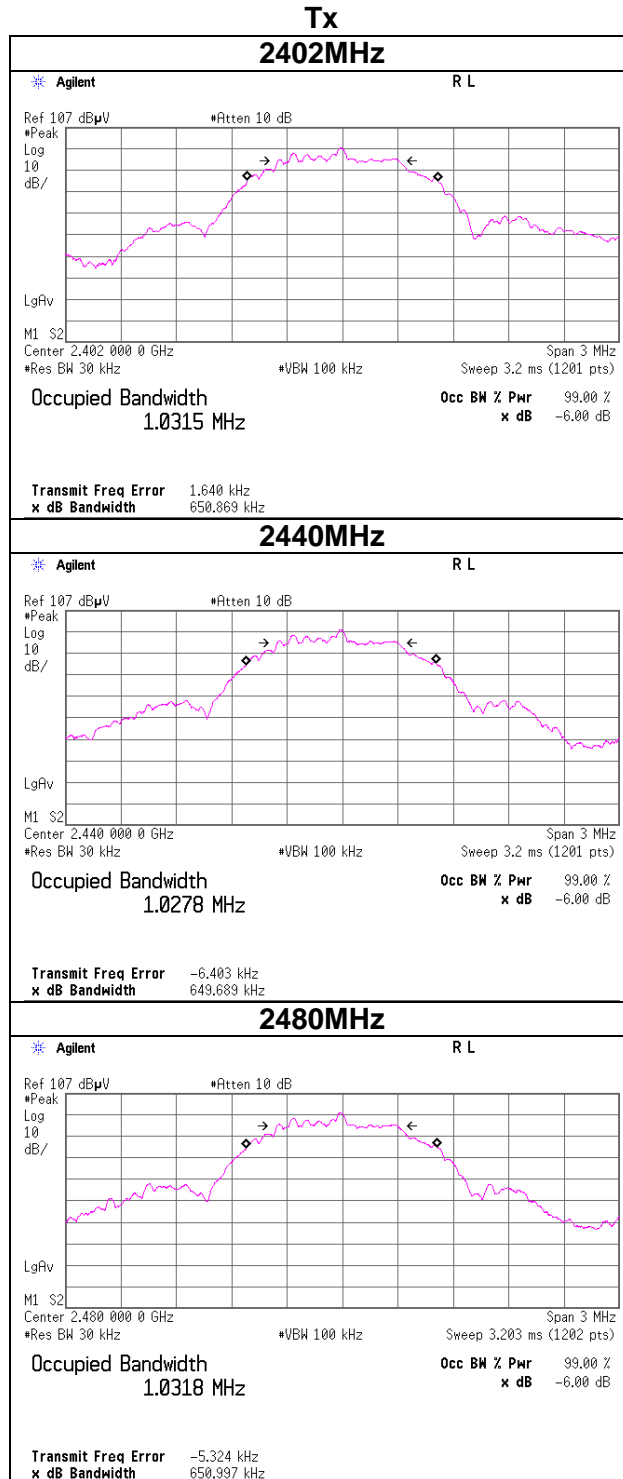

6.1.3. MAXIMUM PEAK OUTPUT POWER

LIMITS

FCC §15.247 (b)

IC RSS-210 A8.4

The maximum antenna gain is less than or equal to 6 dBi, therefore the limit is 30 dBm.

TEST PROCEDURE

Peak power is measured using a wide bandwidth Peak Power Meter.

RESULTS

Freq. [MHz]	Reading Power Meter(PK) [dBm]	Cable Loss [dB]	Atten. [dB]	Result		Limit		Margin [dB]
				[dBm]	[mW]	[dBm]	[mW]	
2402	-7.12	2.13	6.11	1.12	1.29	30.00	1000	28.88
2440	-6.71	2.15	6.11	1.55	1.43	30.00	1000	28.45
2480	-6.92	2.16	6.11	1.35	1.36	30.00	1000	28.65

Sample Calculation:

Result = Reading + Cable Loss + Attenuator

6.1.4. AVERAGE POWER

LIMIT

None; for reporting purposes only.

TEST PROCEDURE

The transmitter output is connected to a power meter.

RESULTS

Freq. [MHz]	Reading Power Meter(AV) [dBm]	Cable Loss [dB]	Atten. [dB]	Result	
				[dBm]	[mW]
2402.0	-9.71	2.13	6.11	-1.47	0.71
2440.0	-9.21	2.15	6.11	-0.95	0.80
2480.0	-9.38	2.16	6.11	-1.11	0.77

Sample Calculation:

Result = Reading + Cable Loss + Attenuator

6.1.5. POWER SPECTRAL DENSITY

LIMITS

FCC §15.247 (e)

IC RSS-210 A8.2 (b)

The power spectral density conducted from the transmitter to the antenna shall not be greater than 8 dBm in any 3 kHz band during any time interval of continuous transmission.

TEST PROCEDURE

Output power was measured based on the use of a peak measurement, therefore the power spectral density was measured using PSD Option 1 in accordance with FCC document "Measurement of Digital Transmission Systems Operating under Section 15.247", March 23, 2005.

RESULTS

Freq. [MHz]	Reading [dBm]	Cable Loss [dB]	Atten. [dB]	Result [dBm]	Limit [dBm]	Margin [dB]
2402.00	-23.02	2.13	6.11	-14.78	8.00	22.78
2440.00	-22.56	2.15	6.11	-14.30	8.00	22.30
2480.00	-22.80	2.16	6.11	-14.53	8.00	22.53

Sample Calculation:

$$\text{Result} = \text{Reading} + \text{Cable Loss} + \text{Attenuator}$$

POWER SPECTRAL DENSITY

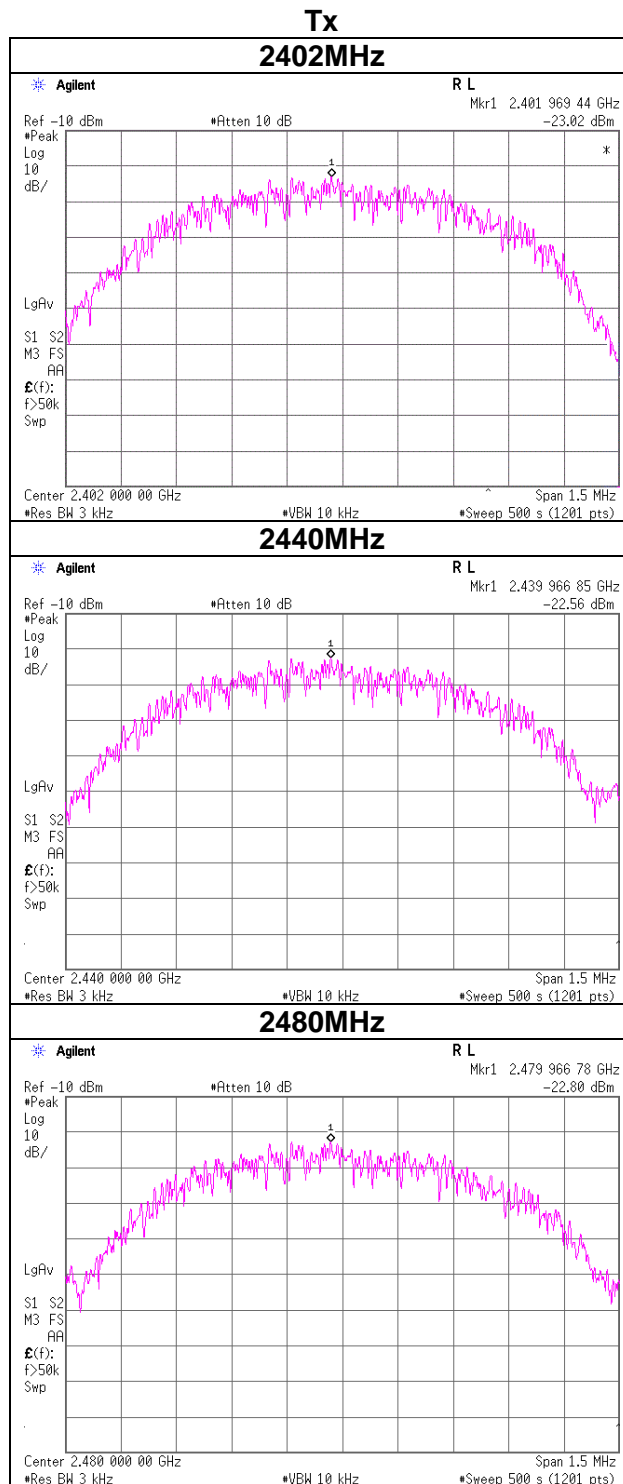

6.1.6. CONDUCTED SPURIOUS EMISSIONS

LIMITS

FCC §15.247 (d)

IC RSS-210 A8.5

Output power was measured based on the use of a peak measurement, therefore the required attenuation is 20 dB.

TEST PROCEDURE

The transmitter output is connected to a spectrum analyzer. The resolution bandwidth is set to 100 kHz. The video bandwidth is set to 300 kHz.

The spectrum from 9 kHz to 25 GHz is investigated with the transmitter set to the lowest, middle, and highest channels.

RESULTS

SPURIOUS EMISSIONS, LOW CHANNEL

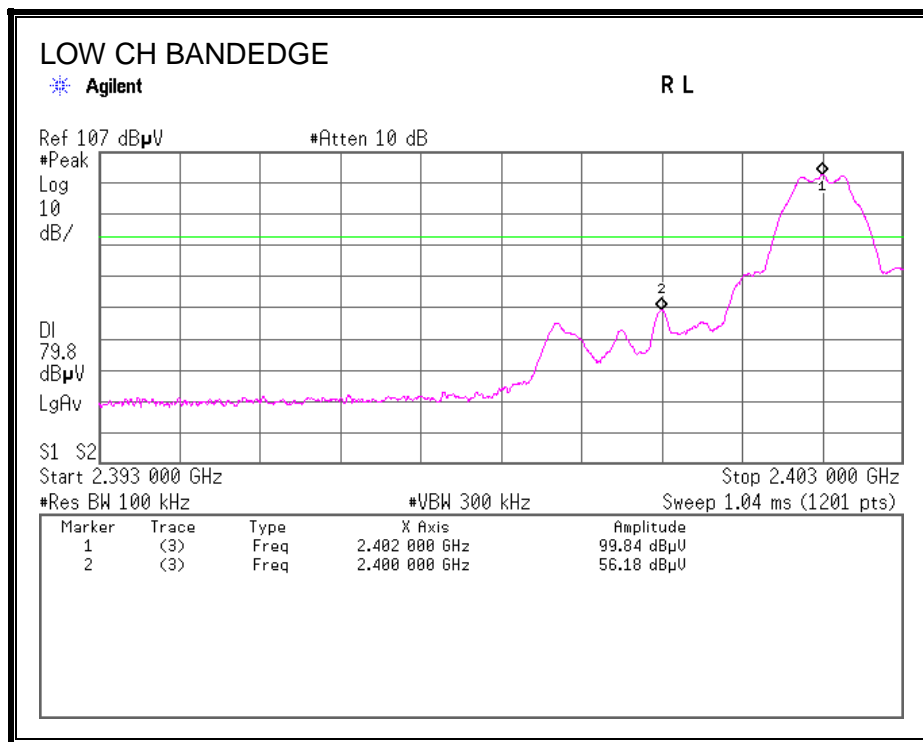

Tx 2402MHz

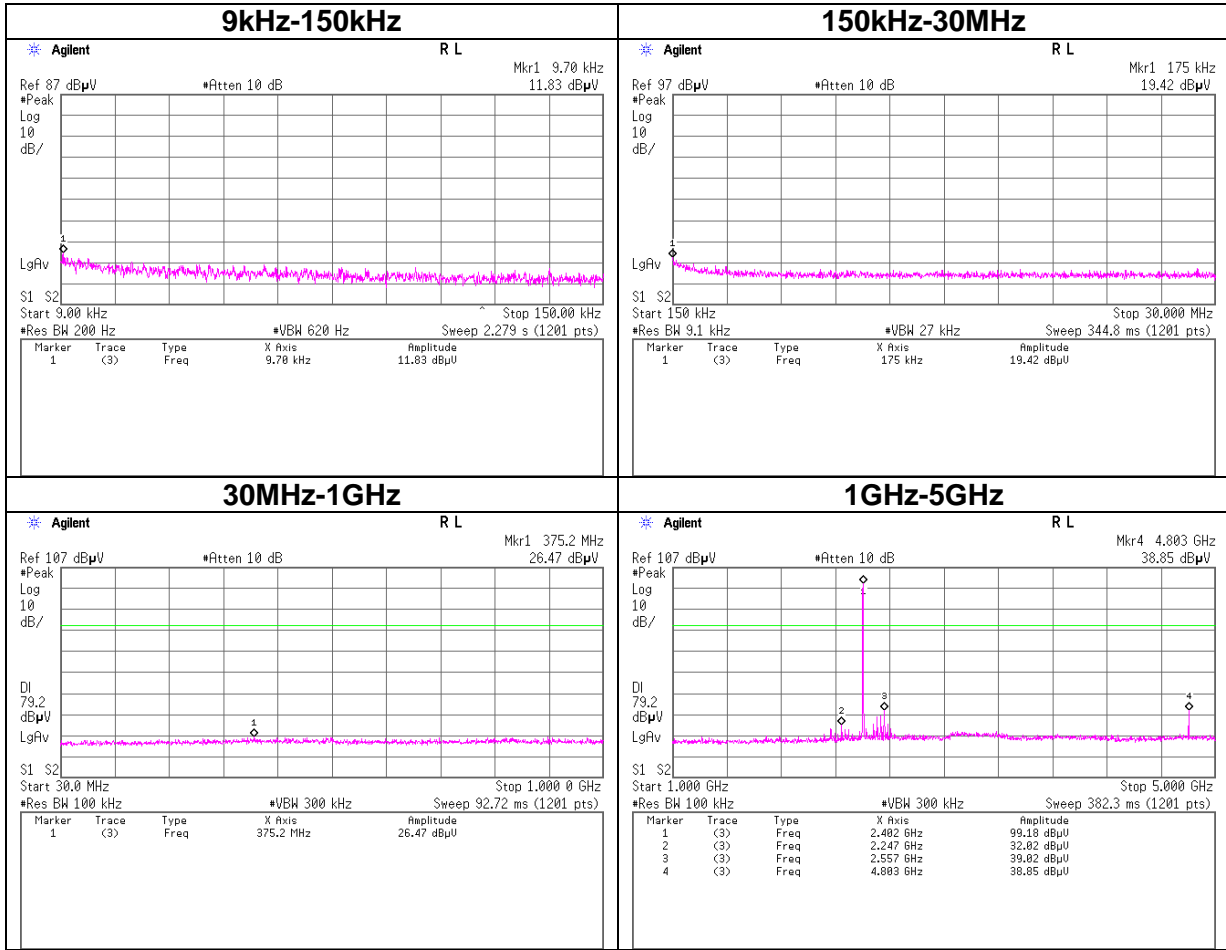

Tx 2402MHz

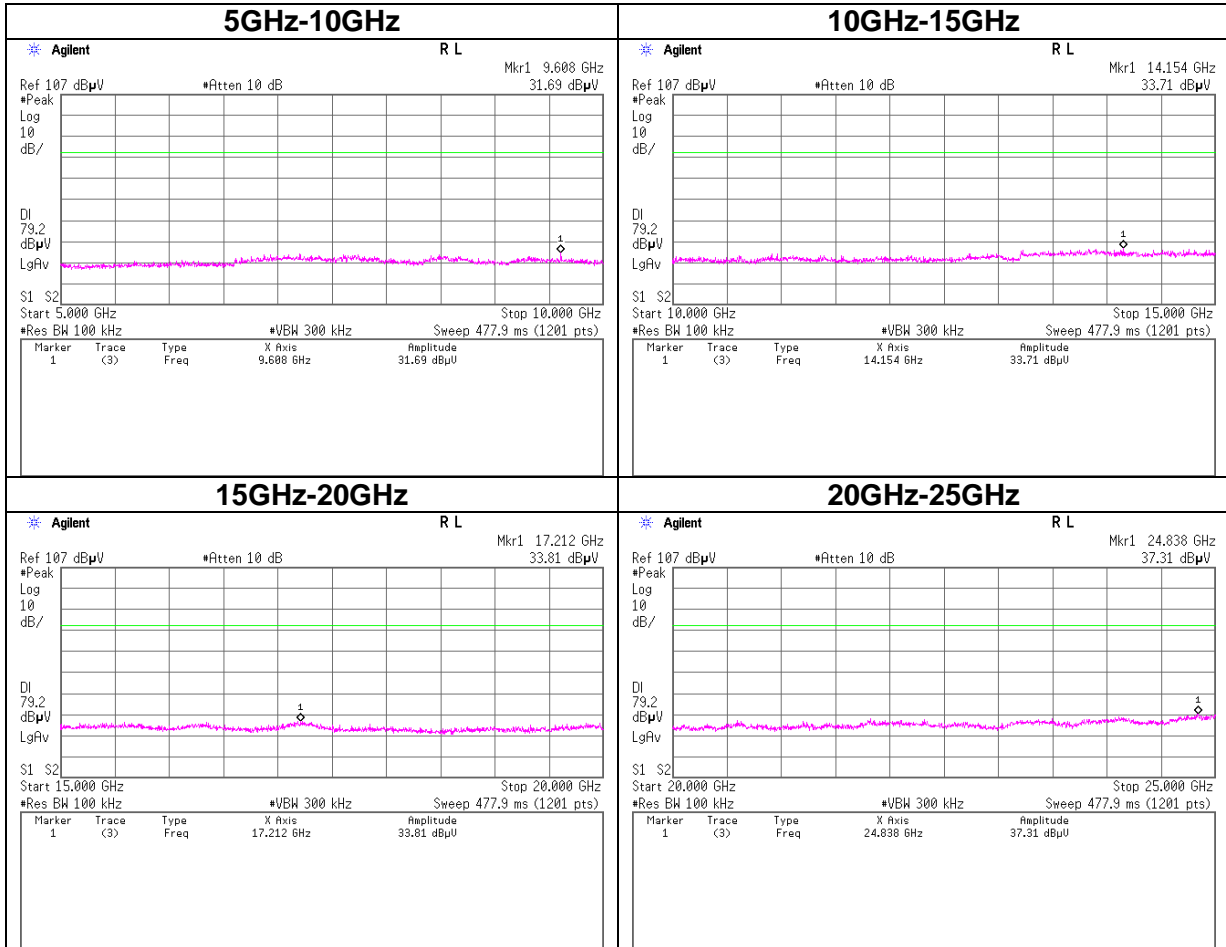

SPURIOUS EMISSIONS, MID CHANNEL

Tx 2440MHz

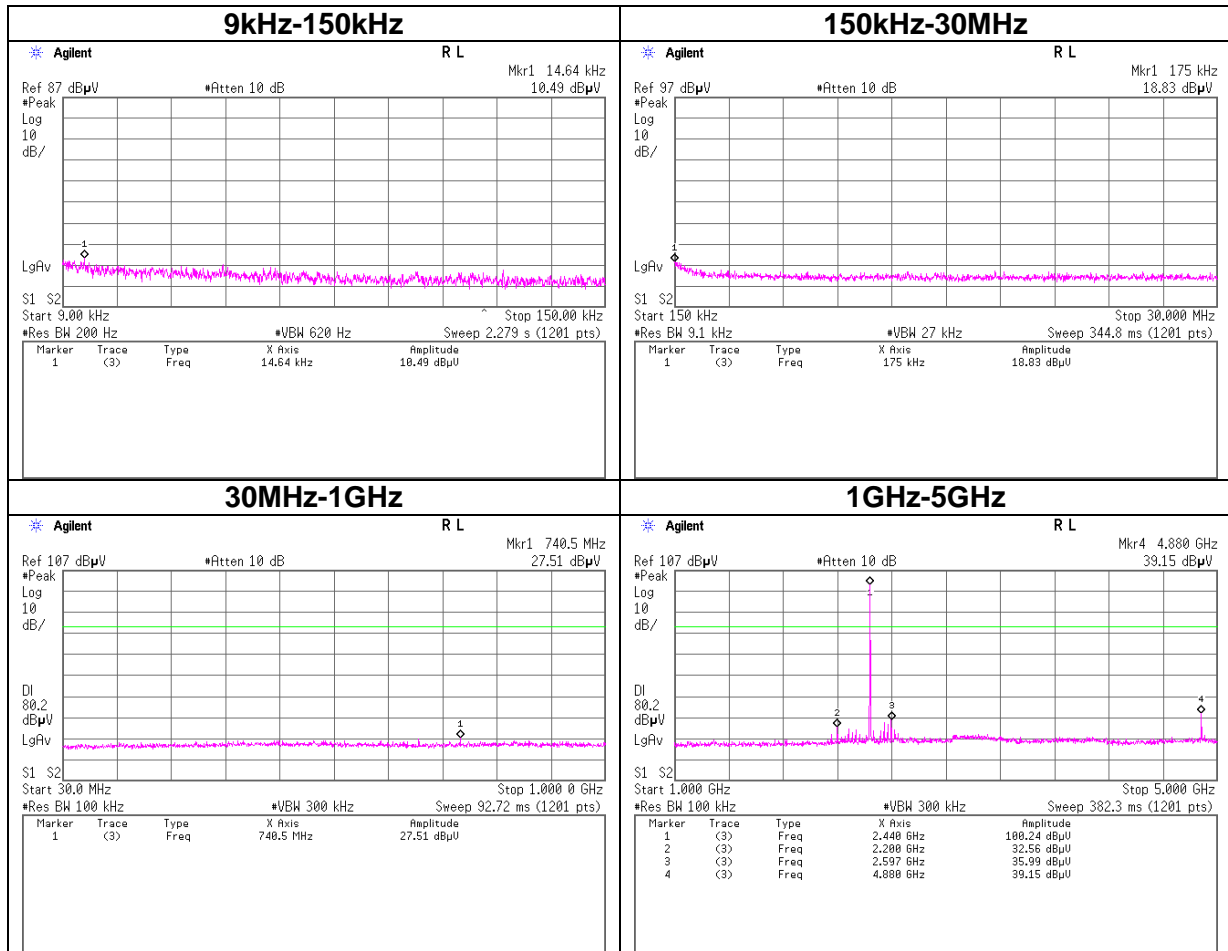

Tx 2440MHz

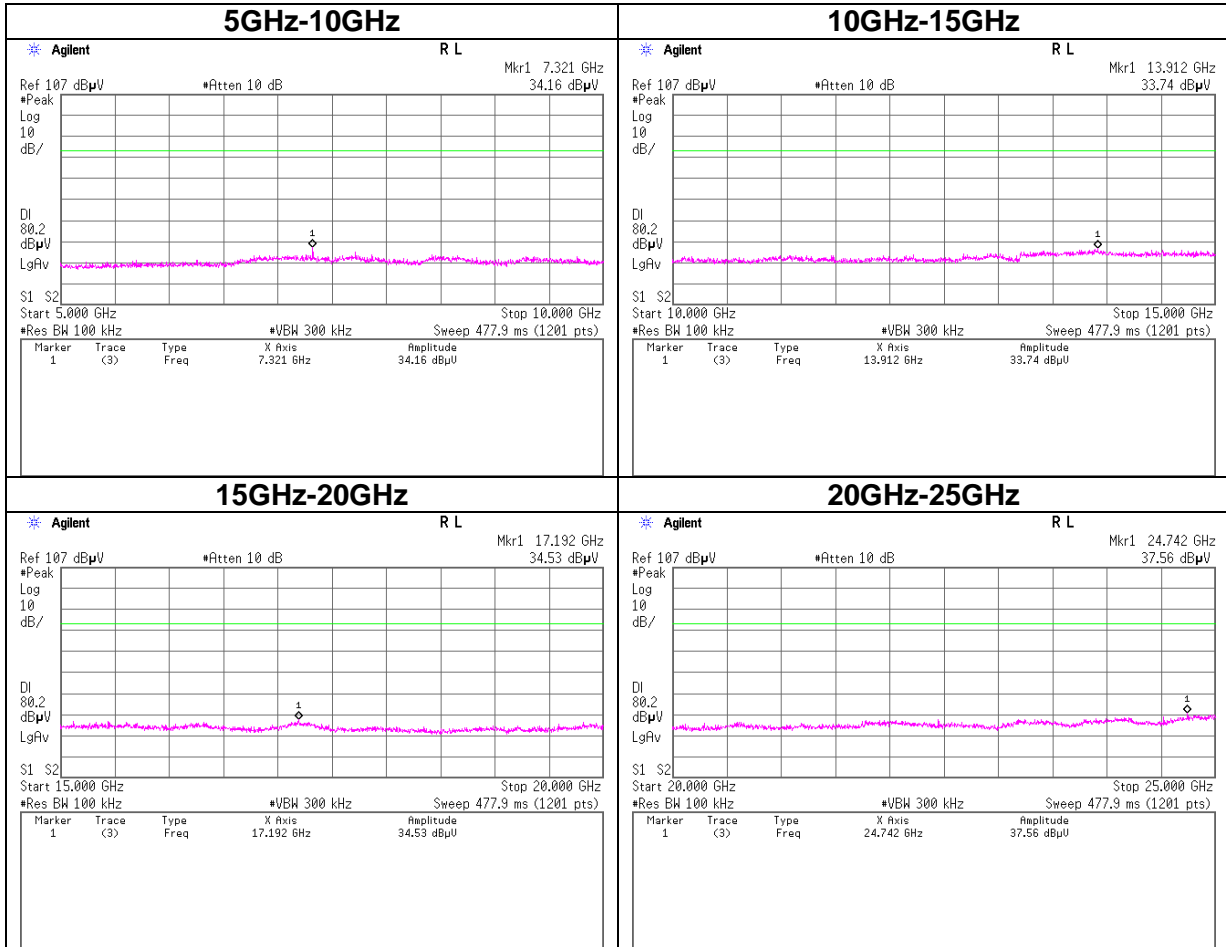

SPURIOUS EMISSIONS, HIGH CHANNEL

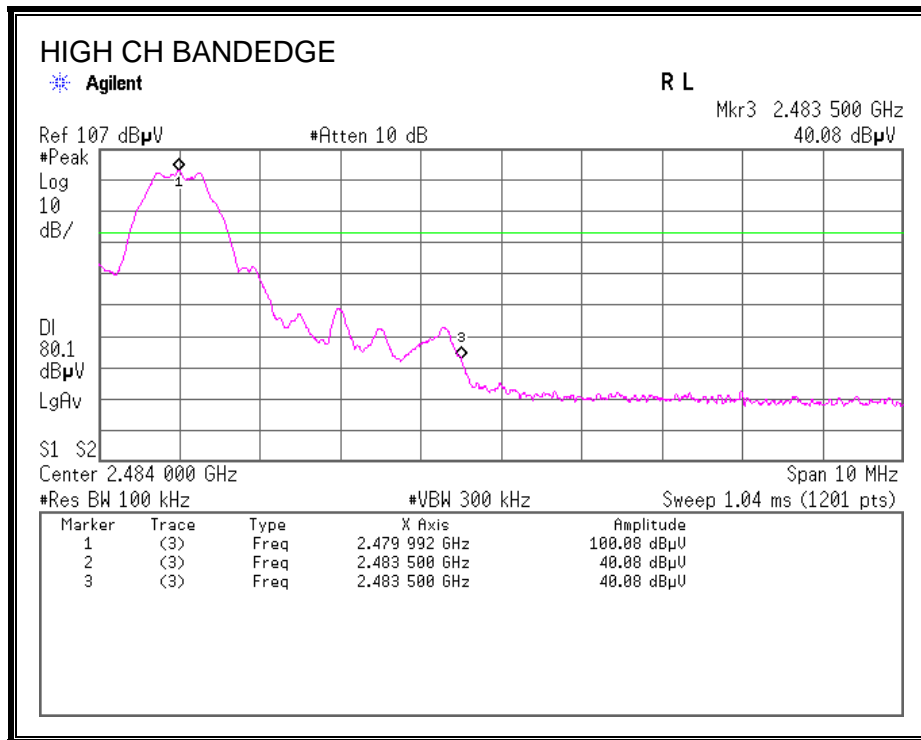

Tx 2480MHz

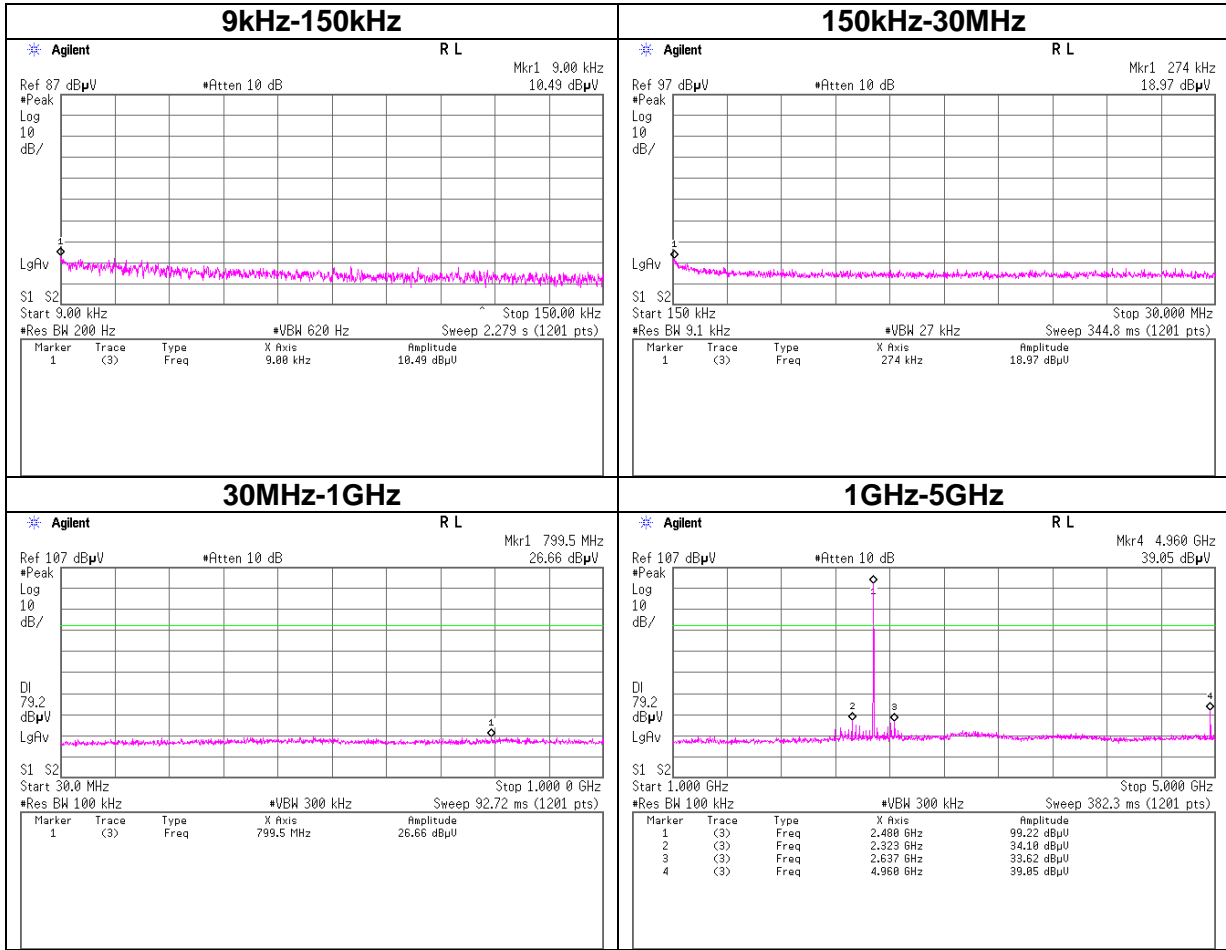

Tx 2480MHz

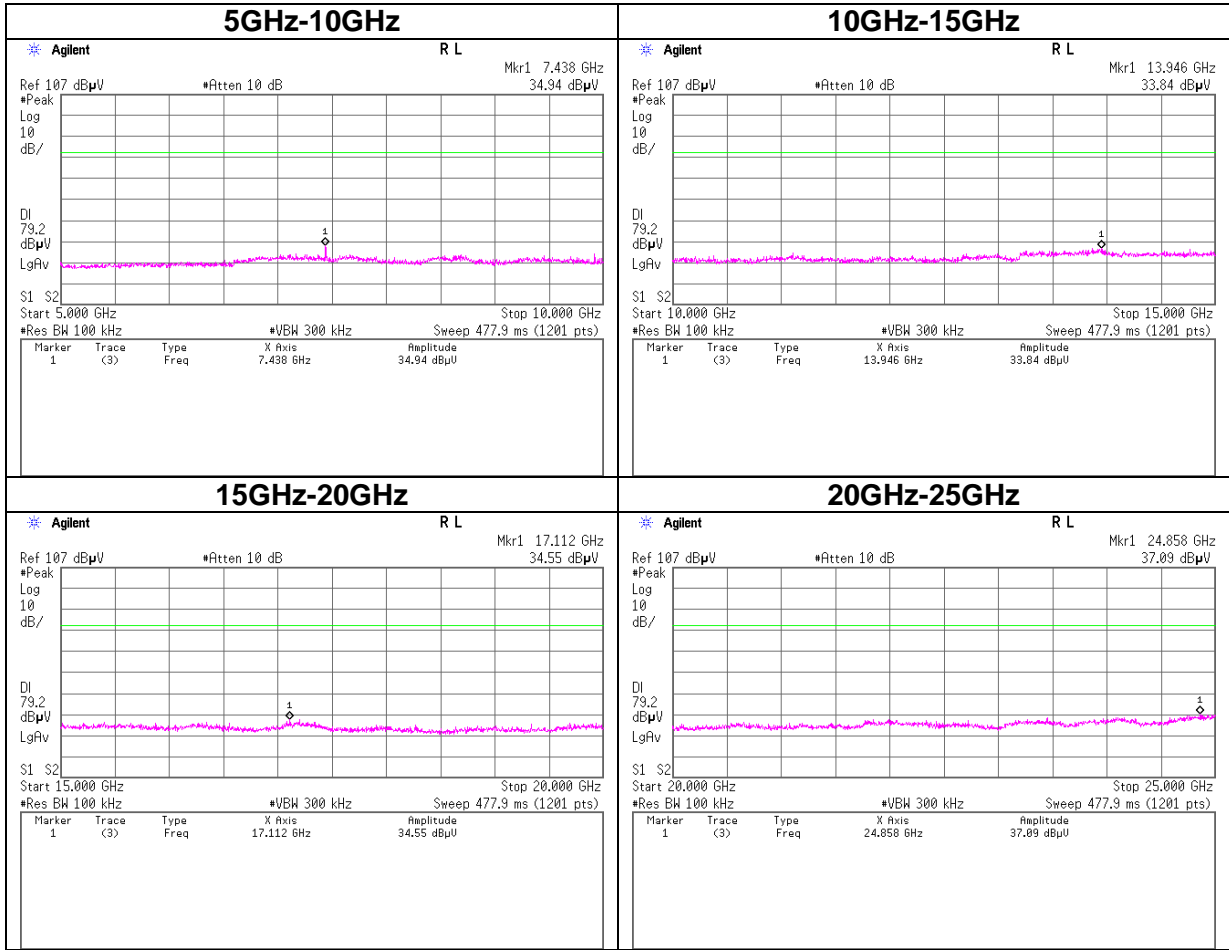

7. RADIATED TEST RESULTS

7.1. LIMITS AND PROCEDURE

LIMITS

FCC §15.205 and §15.209

IC RSS-210 Clause 2.5 (Transmitter)

Frequency Range (MHz)	Field Strength Limit (uV/m) at 3 m	Field Strength Limit (dBuV/m) at 3 m
30 - 88	100	40
88 - 216	150	43.5
216 - 960	200	46
Above 960	500	54

TEST PROCEDURE

The EUT is placed on a non-conducting table 80 cm above the ground plane. The antenna to EUT distance is 3 meters. The EUT is configured in accordance with ANSI C63.4. The EUT is set to transmit in a continuous mode.

For measurements below 1 GHz the resolution bandwidth is set to 100 kHz for peak detection measurements or 120 kHz for quasi-peak detection measurements. Peak detection is used unless otherwise noted as quasi-peak.

For measurements above 1 GHz the resolution bandwidth is set to 1 MHz, then the video bandwidth is set to 3 MHz for peak measurements and 10 Hz for average measurements.

The spectrum from 30 MHz to 26.5 GHz is investigated with the transmitter set to the lowest, middle, and highest channels in the 2.4 GHz band.

The frequency range of interest is monitored at a fixed antenna height and EUT azimuth. The EUT is rotated through 360 degrees to maximize emissions received. The antenna is scanned from 1 to 4 meters above the ground plane to further maximize the emission. Measurements are made with the antenna polarized in both the vertical and the horizontal positions.

Radiated Spurious Emission

Test place Head Office EMC Lab. No.4 Semi Anechoic Chamber
 Report No. 32KE0147-HO
 Date 06/22/2012 06/30/2012
 Temperature/ Humidity 24 deg.C/ 53% RH 24 deg.C/ 63% RH
 Engineer Satofumi Motoya Imura
 Matsuyama
 (Above 1GHz) (30-1000MHz)
 Mode BT Low Energy Tx 2440MHz

Polarity	Frequency [MHz]	Detector	Reading [dBuV]	Ant.Fac. [dB/m]	Loss [dB]	Gain [dB]	Result [dBuV/m]	Limit [dBuV/m]	Margin [dB]	Remark
Hori	41.560	QP	24.4	14.2	7.3	32.0	13.9	40.0	26.1	
Hori	99.638	QP	44.2	10.1	8.1	32.1	30.3	43.5	13.2	
Hori	150.622	QP	33.4	15.0	8.5	32.0	24.9	43.5	18.6	
Hori	168.432	QP	39.4	15.7	8.7	32.0	31.8	43.5	11.7	
Hori	400.000	QP	38.8	17.6	10.3	32.0	34.7	46.0	11.3	
Hori	451.688	QP	37.0	18.3	10.6	31.9	34.0	46.0	12.0	
Hori	4880.000	PK	47.6	31.4	4.3	31.5	51.8	73.9	22.1	
Hori	4880.000	AV	38.0	31.4	4.3	31.5	42.2	53.9	11.7	
Vert	41.560	QP	35.8	14.2	7.3	32.0	25.3	40.0	14.7	
Vert	99.638	QP	40.5	10.1	8.1	32.1	26.7	43.5	16.8	
Vert	150.621	QP	30.1	15.0	8.5	32.0	21.7	43.5	21.8	
Vert	168.522	QP	31.2	15.7	8.7	32.0	23.7	43.5	19.8	
Vert	400.000	QP	33.2	17.6	10.3	32.0	29.1	46.0	16.9	
Vert	451.680	QP	34.2	18.3	10.6	31.9	31.2	46.0	14.8	
Vert	4880.000	PK	46.7	31.4	4.3	31.5	50.9	73.9	23.0	
Vert	4880.000	AV	36.1	31.4	4.3	31.5	40.3	53.9	13.6	

Result = Reading + Ant Factor + Loss (Cable+Attenuator+Filter-Distance factor(above 10GHz)) - Gain(Amplifier)

*Other frequency noises omitted in this report were not seen or had enough margin (more than 20dB).

Distance factor: 10GHz-26.5GHz 20log(3.0m/1.0m)= 9.5dB

Radiated Spurious Emission

Test place Head Office EMC Lab. No.4 Semi Anechoic Chamber
 Report No. 32KE0147-HO
 Date 06/22/2012 06/30/2012
 Temperature/ Humidity 24 deg.C/ 53% RH 24 deg.C/ 63% RH
 Engineer Satofumi Motoya Imura
 Matsuyama
 (Above 1GHz) (30-1000MHz)
 Mode BT Low Energy Tx 2480MHz

Polarity	Frequency [MHz]	Detector	Reading [dBuV]	Ant.Fac. [dB/m]	Loss [dB]	Gain [dB]	Result [dBuV/m]	Limit [dBuV/m]	Margin [dB]	Remark
Hori	41.558	QP	24.3	14.2	7.3	32.0	13.8	40.0	26.2	
Hori	99.641	QP	44.3	10.1	8.1	32.1	30.4	43.5	13.1	
Hori	150.624	QP	33.6	15.0	8.5	32.0	25.1	43.5	18.4	
Hori	168.512	QP	39.7	15.7	8.7	32.0	32.1	43.5	11.4	
Hori	400.000	QP	39.1	17.6	10.3	32.0	35.0	46.0	11.0	
Hori	451.769	QP	36.5	18.3	10.6	31.9	33.5	46.0	12.5	
Hori	2483.500	PK	52.3	28.5	2.4	32.2	51.0	73.9	22.9	
Hori	4960.000	PK	47.8	31.6	4.3	31.5	52.2	73.9	21.7	
Hori	2483.500	AV	38.4	28.5	2.4	32.2	37.1	53.9	16.8	
Hori	4960.000	AV	37.8	31.6	4.3	31.5	42.2	53.9	11.7	
Vert	41.550	QP	35.9	14.2	7.3	32.0	25.4	40.0	14.6	
Vert	99.645	QP	40.6	10.1	8.1	32.1	26.8	43.5	16.7	
Vert	150.624	QP	30.1	15.0	8.5	32.0	21.7	43.5	21.8	
Vert	168.531	QP	31.2	15.7	8.7	32.0	23.7	43.5	19.8	
Vert	400.000	QP	33.1	17.6	10.3	32.0	29.0	46.0	17.0	
Vert	451.767	QP	34.3	18.3	10.6	31.9	31.3	46.0	14.7	
Vert	2483.500	PK	50.0	28.5	2.4	32.2	48.7	73.9	25.2	
Vert	4960.000	PK	46.6	31.6	4.3	31.5	51.0	73.9	22.9	
Vert	2483.500	AV	35.9	28.5	2.4	32.2	34.6	53.9	19.3	
Vert	4960.000	AV	36.0	31.6	4.3	31.5	40.4	53.9	13.5	

Result = Reading + Ant Factor + Loss (Cable+Attenuator+Filter-Distance factor(above 10GHz)) - Gain(Amplifier)

*Other frequency noises omitted in this report were not seen or had enough margin (more than 20dB).

Distance factor: 10GHz-26.5GHz 20log(3.0m/1.0m)= 9.5dB

8. AC POWER LINE CONDUCTED EMISSIONS

LIMITS

FCC §15.207 (a)

RSS-Gen 7.2.2

Frequency of Emission (MHz)	Conducted Limit (dBuV)	
	Quasi-peak	Average
0.15-0.5	66 to 56*	56 to 46*
0.5-5	56	46
5-30	60	50

*Decreases with the logarithm of the frequency.

TEST PROCEDURE

The EUT is placed on a non-conducting table 40 cm from the vertical ground plane and 80 cm above the horizontal ground plane. The EUT is configured in accordance with ANSI C63.4.

The receiver is set to a resolution bandwidth of 9 kHz. Peak detection is used unless otherwise noted as quasi-peak or average.

Line conducted data is recorded for both NEUTRAL and HOT lines.

RESULTS

Conducted Emission

DATA OF CONDUCTED EMISSION TEST

UL Japan, Inc. Head Office EMC Lab. No.4 Semi Anechoic Chamber
 Date : 2012/06/30

Report No. : 32KE0147-HO
 Power : AC 120V / 60Hz
 Temp./Humi. : 24deg. C / 63% RH
 Engineer : Motoya Imura

Mode / Remarks : Tx LE 2440MHz

LIMIT : FCC15.207 QP
 FCC15.207 AV

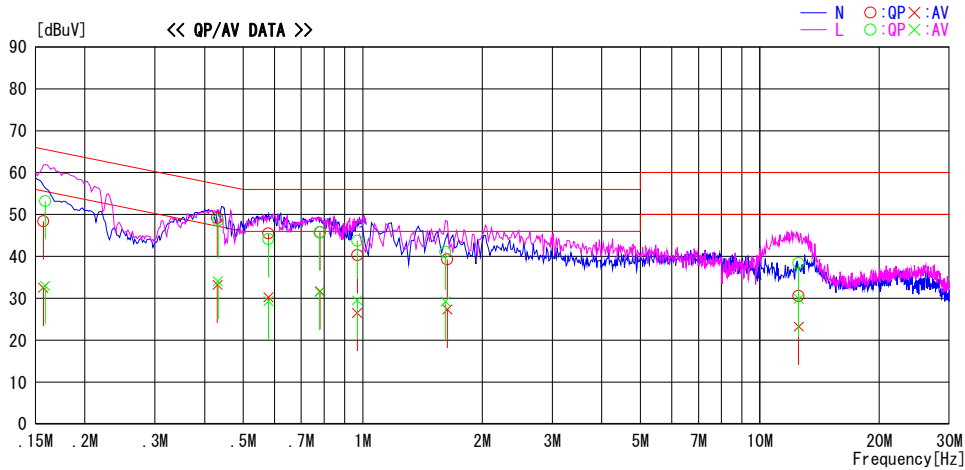

Frequency [MHz]	Reading Level		Corr. Factor [dB]	Results		Limit		Margin		Phase	Comment
	QP [dBuV]	AV [dBuV]		QP [dBuV]	AV [dBuV]	QP [dBuV]	AV [dBuV]	QP [dB]	AV [dB]		
0.15697	35.1	19.2	13.3	48.4	32.5	65.6	55.6	17.2	23.1	N	
0.43070	35.9	19.9	13.3	49.2	33.2	57.2	47.2	8.0	14.0	N	
0.57890	32.2	16.9	13.3	45.5	30.2	56.0	46.0	10.5	15.8	N	
0.78115	32.4	18.4	13.3	45.7	31.7	56.0	46.0	10.3	14.3	N	
0.96944	27.0	13.2	13.3	40.3	26.5	56.0	46.0	15.7	19.5	N	
1.63435	25.9	13.9	13.4	39.3	27.3	56.0	46.0	16.7	18.7	N	
12.52915	16.3	8.9	14.3	30.6	23.2	60.0	50.0	29.4	26.8	N	
0.15872	39.9	19.7	13.3	53.2	33.0	65.5	55.5	12.3	22.5	L	
0.43245	35.3	20.8	13.3	48.6	34.1	57.2	47.2	8.6	13.1	L	
0.57890	30.8	16.0	13.3	44.1	29.3	56.0	46.0	11.9	16.7	L	
0.77940	32.4	18.2	13.3	45.7	31.5	56.0	46.0	10.3	14.5	L	
0.96944	30.4	16.2	13.3	43.7	29.5	56.0	46.0	12.3	16.5	L	
1.61617	27.7	15.8	13.4	41.1	29.2	56.0	46.0	14.9	16.8	L	
12.52153	24.1	15.6	14.3	38.4	29.9	60.0	50.0	21.6	20.1	L	

CHART: WITH FACTOR, Peak hold data. CALCULATION: RESULT=READING+C, F (LISN LOSS+ATT LOSS +CABLE LOSS)
 Except for the above table : adequate margin data below the limits.

Conducted Emission

Test place	Head Office EMC Lab. No.4 Semi Anechoic Chamber
Date	06/17/2012
Temperature/ Humidity	24 deg.C/ 60% RH
Engineer	Motoya Imura
Mode	Tx LE

