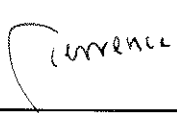
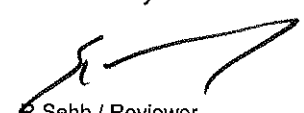

Produkte
Products

Prüfbericht - Nr.: 12604528 003		Seite 1 von 61 Page 1 of 61			
<i>Test Report No.:</i>					
Auftraggeber: <i>Client:</i>		Matsushita Electric Industrial Co., Ltd 4-3-1 Tsunashima-Higashi, Kohoku-ku, Yokohama 223-8639, Japan			
Gegenstand der Prüfung: <i>Test item:</i>		Order Taker (O/T)			
Bezeichnung: <i>Identification:</i>	WX-T3020	Serien-Nr.: <i>Serial No.:</i>	Pre-production		
Wareneingangs-Nr.: <i>Receipt No.:</i>	213080562	Eingangsdatum: <i>Date of receipt:</i>	2008-06-20		
Prüfart: <i>Testing location:</i>	TÜV Rheinland Japan Ltd. - Global Technology Assessment Center 4-25-2 Kita-Yamata, Tsuzuki-ku, Yokohama 224-0021, Japan				
Prüfgrundlage: <i>Test specification:</i>	47 CFR Part 15.247 (Subpart: B) 47 CFR Part 15 (Subpart: D) ANSI C63.4-2003 ANSI C63.17-1998 RSS-213 (Issue 2): 2007 RSS-Gen (Issue 2): 2007				
Prüfergebnis: <i>Test Result:</i>	Der Prüfgegenstand entspricht oben genannter Prüfgrundlage(n). <i>The test item passed the test specification(s).</i>				
Prüflaboratorium: <i>Testing Laboratory:</i>	TÜV Rheinland Japan Ltd. - Global Technology Assessment Center 4-25-2 Kita-Yamata, Tsuzuki-ku, Yokohama 224-0021, Japan				
geprüft/ tested by:		kontrolliert/ reviewed by:			
2008-09-10 T.Cheung / Inspector 		2008-09-10  R.Sehb / Reviewer			
Datum <i>Date</i>	Name/Stellung <i>Name/Position</i>	Unterschrift <i>Signature</i>	Datum <i>Date</i>	Name/Stellung <i>Name/Position</i>	Unterschrift <i>Signature</i>
Sonstiges / Other Aspects:					
Abkürzungen: P(ass) = entspricht Prüfgrundlage F(all) = entspricht nicht Prüfgrundlage N/A = nicht anwendbar N/T = nicht getestet					
Abbreviations: P(ass) = passed F(all) = failed N/A = not applicable N/T = not tested					
Dieser Prüfbericht bezieht sich nur auf das o.g. Prüfmuster und darf ohne Genehmigung der Prüfstelle nicht auszugswise vervielfältigt werden. Dieser Bericht berechtigt nicht zur Verwendung eines Prüfzeichens. <i>This test report relates to the a. m. test sample. Without permission of the test center this test report is not permitted to be duplicated in extracts. This test report does not entitle to carry any safety mark on this or similar products.</i>					

Prüfbericht - Nr.: 12604528 003
Test Report No.:

Seite 2 von 61
Page 2 of 61

TEST SUMMARY

3.2.1 ANTENNA REQUIREMENTS FCC 15.203, 15.303(c)(8), FCC 15.204 AND RSS-213 §4.3.4(B)(8)

RESULT: PASS

5.1.1 CONDUCTED OUTPUT POWER AT ANTENNA TERMINALS FCC 15.319(C) AND RSS-213 § 6.5

RESULT: PASS

5.1.2 26dB BANDWIDTH FCC 15.303(c),15.323(A) AND RSS-213 § 6.4

RESULT: PASS

5.1.3 IN-BAND UNWANTED EMISSIONS, EMISSIONS FCC 15.323(D) AND RSS-213 §6.7.2

RESULT: PASS

5.1.4 OUT-OF-BAND UNWANTED EMISSIONS, EMISSIONS FCC 15.323(D) AND RSS-213 § 6.7.1

RESULT: PASS

5.1.5 PEAK POWER SPECTRAL DENSITY FCC 15.319(D) AND RSS-213 § 6.6

RESULT: PASS

6.1.1 MAINS TERMINAL CONTINUOUS DISTURBANCE VOLTAGE FCC PART 15.207

RESULT: N/A

6.1.2 MAINS TERMINAL CONTINUOUS DISTURBANCE VOLTAGE FCC PART 15.107

RESULT: N/A

6.1.3 MAINS TERMINAL CONTINUOUS DISTURBANCE VOLTAGE FCC PART 15.107

RESULT: N/A

7.1.1 RADIATED EMISSION RECEIVER/DIGITAL SPURIOUS

RESULT: PASS

8.1.1 AUTOMATIC DISCONTINUATION OF TRANSMISSION FCC 15.319(F) AND RSS-213 § 4.3.4(A)

RESULT: PASS

8.1.2 LISTEN BEFORE TRANSMIT FCC 15.323(c)

RESULT: PASS

8.1.3 MONITORING TIME FCC 15.323(c)(1) AND RSS-213 § 4.3.4(B)

RESULT: PASS

8.1.4 MONITORING THRESHOLD, LEAST INTERFERED CHANNEL FCC 15.323(c)(2)(5) AND RSS-213 § 4.3.4(B)

RESULT: PASS

8.1.5 SYSTEM ACKNOWLEDGMENT AND MAXIMUM TRANSMIT PERIOD 15.323(c)(3)(4) AND RSS-213 §4.3.4(B)

RESULT: PASS

8.1.6 CHANNEL CONFIRMATION PERIOD 15.323(c)(5) AND RSS-213 § 4.3.4(B)

RESULT: PASS

Prüfbericht - Nr.: 12604528 003

Seite 3 von 61

Test Report No.:

Page 3 of 61

8.1.7 SYSTEM ACKNOWLEDGMENT AND MAXIMUM TRANSMIT PERIOD 15.323(c)(5) AND RSS-213 §4.3.4(B)(5)

RESULT: PASS

8.1.8 SEGMENT OCCUPANCY 15.323(c)(5) AND RSS-213 §4.3.4(B)(5)

RESULT: PASS

8.1.9 RANDOM WAITING 15.323(c)(6) AND RSS-213 §4.3.4(B)(6)

RESULT: N/A

8.1.10 MONITORING BANDWIDTH 15.323(c)(7) AND RSS-213 §4.3.4(B)(7)

RESULT: N/A

8.1.11 MONITORING REACTION TIME 15.323(c)(7) AND RSS-213 §4.3.4(B)(7)

RESULT: PASS

8.1.12 MONITORING THRESHOLD RELAXATION 15.323(c)(9) AND RSS-213 §4.3.4(B)(9)

RESULT: N/A

8.1.13 DUPLEX SYSTEM LBT 15.323(c)(10) AND RSS-213 §4.3.4(B)(10)

RESULT: N/A

8.1.14 ALTERNATIVE MONITORING INTERVAL 15.323(c)(11) AND RSS-213 §4.3.4(B)(11)

RESULT: N/A

8.1.15 FAIR ACCESS 15.323(c)(12) AND RSS-213 §4.3.4(B)(12)

RESULT: N/A

8.1.16 FRAME PERIOD 15.323(E) AND RSS-213 §4.3.4(C)

RESULT: PASS

8.1.17 FREQUENCY STABILITY 15.323(F) AND RSS-213 §6.2

RESULT: PASS

Contents

1.	GENERAL REMARKS	6
1.1	COMPLEMENTARY MATERIALS	6
1.2	FCC CROSS-REFERENCE TABLE	6
2.	TEST SITES	7
2.1	TEST FACILITIES	7
2.2	LIST OF TEST AND MEASUREMENT INSTRUMENTS	8
2.3	MEASUREMENT UNCERTAINTY	9
3.	GENERAL PRODUCT INFORMATION	10
3.1	PRODUCT FUNCTION AND INTENDED USE	10
3.2	SYSTEM DETAILS	10
3.2.1	<i>Antenna Requirements FCC 15.203, 15.303(c)(8), FCC 15.204 and RSS-213 §4.3.4(b)(8)....</i>	<i>11</i>
3.3	CLOCK FREQUENCIES	11
3.4	INDEPENDENT OPERATION MODES	11
3.5	NOISE SUPPRESSING PARTS	11
4.	TEST SET-UP AND OPERATION MODES	12
4.1	TEST METHODOLOGY	12
4.2	PHYSICAL CONFIGURATION FOR TESTING	12
4.3	TEST OPERATION AND TEST SOFTWARE	13
4.4	SPECIAL ACCESSORIES AND AUXILIARY EQUIPMENT	13
5.	TEST RESULTS CONDUCTED TESTING AT ANTENNA PORT	14
5.1.1	<i>Conducted Output Power at Antenna Terminals FCC 15.319(c) and RSS-213 §6.5.....</i>	<i>14</i>
5.1.2	<i>26dB Bandwidth FCC 15.303(c), 15.323(a) and RSS-213 §6.4</i>	<i>18</i>
5.1.3	<i>In-Band Unwanted Emissions, Emissions FCC 15.323(d) and RSS-213 §6.7.2</i>	<i>22</i>
5.1.4	<i>Out-of-Band Unwanted Emissions, Emissions FCC 15.323(d) and RSS-213 §6.7.1.....</i>	<i>25</i>
5.1.5	<i>Peak Power Spectral Density FCC 15.319(d) and RSS-213 §6.6</i>	<i>33</i>
6.	TEST RESULTS CONDUCTED EMISSIONS	35
6.1.1	<i>Mains Terminal Continuous Disturbance Voltage FCC part 15.207</i>	<i>35</i>
6.1.2	<i>Mains Terminal Continuous Disturbance Voltage FCC part 15.107</i>	<i>35</i>
6.1.3	<i>Mains Terminal Continuous Disturbance Voltage FCC part 15.107</i>	<i>35</i>
7.	TEST RESULTS SPURIOUS	36
7.1.1	<i>Radiated Emission Receiver/Digital spurious.....</i>	<i>36</i>
8.	VERIFICATION OF ACCESS PROTOCOLS	39
8.1.1	<i>Automatic Discontinuation of Transmission FCC 15.319(f) and RSS-213 §4.3.4(a).....</i>	<i>39</i>
8.1.2	<i>Listen before transmit FCC 15.323(c).....</i>	<i>40</i>

8.1.3	Monitoring Time FCC 15.323(c)(1) and RSS-213 §4.3.4(b)	41
8.1.4	Monitoring Threshold, Least Interfered Channel FCC 15.323(c)(2)(5) and RSS-213 §4.3.4(b)	42
8.1.5	System Acknowledgment and Maximum Transmit Period 15.323(c)(3)(4) and RSS-213 §4.3.4(b)	43
8.1.6	Channel Confirmation Period 15.323(c)(5) and RSS-213 §4.3.4(b)	45
8.1.7	System Acknowledgment and Maximum Transmit Period 15.323(c)(5) and RSS-213 §4.3.4(b)(5)	46
8.1.8	Segment Occupancy 15.323(c)(5) and RSS-213 §4.3.4(b)(5)	47
8.1.9	Random Waiting 15.323(c)(6) and RSS-213 §4.3.4(b)(6)	48
8.1.10	Monitoring Bandwidth 15.323(c)(7) and RSS-213 §4.3.4(b)(7)	49
8.1.11	Monitoring Reaction Time 15.323(c)(7) and RSS-213 §4.3.4(b)(7)	50
8.1.12	Monitoring Threshold Relaxation 15.323(c)(9) and RSS-213 §4.3.4(b)(9)	51
8.1.13	Duplex System LBT 15.323(c)(10) and RSS-213 §4.3.4(b)(10)	52
8.1.14	Alternative Monitoring Interval 15.323(c)(11) and RSS-213 §4.3.4(b)(11)	53
8.1.15	Fair Access 15.323(c)(12) and RSS-213 §4.3.4(b)(12)	54
8.1.16	Frame Period 15.323(e) and RSS-213 §4.3.4(c)	55
8.1.17	Frequency Stability 15.323(f) and RSS-213 §6.2	57
9.	PHOTOGRAPHS OF TEST SETUP	58
10.	LIST OF TABLES	60
11.	LIST OF FIGURES	60
12.	LIST OF PHOTOGRAPHS	61

Prüfbericht - Nr.: 12604528 003
Test Report No.:

Seite 6 von 61
Page 6 of 61

1. General Remarks

1.1 Complementary Materials

All attachments are integral parts of this test report.

1.2 FCC Cross-Reference Table

The results of emission measurements and product related information contained in this test report and the attached materials relate to the contents of the FCC standard report in the following way:

FCC § / Heading

1.1 Product Description	See 3.1
1.2 Tested System Details	See 4.2
1.3 Test Methodology	See 4.1
1.4 Test Facility	See 2.1
3.2 EUT Exercise Software	See 4.3
3.3 Special Accessories	See 4.4
3.4 Configuration of Tested System	See 4.2

Prüfbericht - Nr.: 12604528 003
*Test Report No.:*Seite 7 von 61
Page 7 of 61

2. Test Sites

2.1 Test Facilities

TÜV Rheinland Japan Ltd. - Global Technology Assessment Center
4-25-2 Kita-Yamata, Tsuzuki-ku, Yokohama 224-0021, Japan

The used test equipment is in accordance with CISPR 16 for measurement of radio interference.

The Federal Communication Commission has reviewed the technical characteristics of the radiated and conducted emission facility, and has found these test facilities to be in compliance with the requirements of section 2.948 of the FCC rules.

The description of the test facility is listed under FCC registration number 299054

The Industry Canada has reviewed the technical characteristics of the radiated and conducted emission facility, and has found these test facilities to be in compliance
The description of the test facility is listed under O.A.T.S filing number 3466B.

Prüfbericht - Nr.: 12604528 003
Test Report No.:
Seite 8 von 61
Page 8 of 61

2.2 List of Test and Measurement Instruments

Test Equipment calibration is traceable to NIST

Table 1: List of Test and Measurement Equipment

Kind of Equipment	Manufacturer	Model Name	Serial Number	Equipment ID	Calibrated until
Receiver	Rohde & Schwarz	ESU 40	100029	RF-0021	2009-02
Two-Line V-Network (LISN)	Rohde & Schwarz	ENV216	100276	RF-0016	2009-05
Receiver	Rohde & Schwarz	ESU 8	100025	RF-0020	2009-02
RF Selector (10m)	Toyo Corporation	NS4900	0703-182	RF-0029	2009-05
Low Noise Pre-Amplifier	TSJ	MLA-10K01-B01-35	1370750	RF-0253	2009-05
3dB Attenuator 50Ohm	Tamagawa Electronics Co., Ltd.	CFA-01	-	RF-0265	2009-05
Trilog Antenna	Schwarzbeck	VULB9168	0245	RF-0019	2009-05
Biconical Antenna	EMCO	3110B	9603-2379	RF-0207	2009-03
Broad Band Horn Antenna 1-10GHz	Schwarzbeck	BBHA9120B	419	RF-0050	2009-05
Double Ridged Broadband Horn Antenna (2-18GHz)	Toyo Corporation	HAP06-18W	00000025	RF-0065	2009-05
Broad Band Horn Antenna (18-26.5GHz)	Toyo Corporation	HAP18-26N	00000010	RF-0070	2009-05
Band Reject Filter	Nitsuki	NF-49BT	027	RF-0131	2008-12
Microwave Preamplifier, 1-8GHz	Toyo Corporation	TPA0108-40	0634	RF-0052	2008-12
Broad-Band Horn Antenna 1-10GHz	Schwarzbeck	BBHA9120B	420	RF-0051	2009-05
Double Ridged Horn Antenna (2-18GHz)	Schwarzbeck Mess-Electronik	BBHA9120C	400	RF-0064	2009-02
Standard Gain Horn Antenna (18-26.5GHz)	EMCO	3160-09	00069343	RF-0072	2009-02
DC POWER SUPPLY	Agilent	E3646A	MY400046 42	N/A	
Signal Generator	Rohde & Schwarz	SMIQ03B	100581	BT-8041	2009-12
Signal Generator	Rohde & Schwarz	SMIQ03B	835742/060	BT-8026	2011-04
Signal Generator	Rohde & Schwarz	SMR27	100010	BT-8005	2008-08
RF Signal Generator (1GHz-40GHz)	Rohde & Schwarz	SMR40	100498	RF-0074	2009-08

Prüfbericht - Nr.: 12604528 003
*Test Report No.:***Seite 9 von 61**
Page 9 of 61

2.3 Measurement Uncertainty

Measurement Type	Frequency	Uncertainty
Antenna Port Conducted Emissions	< 1GHz	±0.39dB
	> 1GHz	±0.68dB
Radiated Emission	9kHz-30MHz	±4.77dB
	30-1000MHz	±5.11dB
	1000-40GHz	±5.19dB

Prüfbericht - Nr.: 12604528 003
Test Report No.:

Seite 10 von 61
Page 10 of 61

3. General Product Information

3.1 Product Function and Intended Use

The **EUT (Equipment Under Test)** is DECT belt-clip worn radio operating in the 1920-1903 MHz band (UPCS). It use with its dedicated headset, in order to operate with a base unit in drive-thru or in quick service restaurant. The communication is controlled by the crews or manager of the quick service restaurant.

3.2 System Details

Radio Standard:	DECT
Specified power output:	19.0dBm
Antenna gain:	+3.09dBi
Antenna type:	Dipole antenna
Mounting type:	Internal
Frequency range:	1920 – 1930 MHz
Number of channel:	5
Frame Period:	10ms
Slots per Frame:	24 slots / 12 RX, 12 TX
Modulation type:	GFSK
FCC Classification:	PUT
Typical Nominal Voltage:	DC 3.7V
Protection Class:	III

UPCS Channel	Frequency MHz
4	1928.448
3	1926.720
2	1924.994
1	1923.264
0	1921.536

Prüfbericht - Nr.: 12604528 003

Test Report No.:

Seite 11 von 61

Page 11 of 61

3.2.1 Antenna Requirements FCC 15.203, 15.303(c)(8), FCC 15.204 and RSS-213 § 4.3.4(b)(8)**RESULT:****PASS**

The EUT has internal antenna which are permanently fixed to the product. Hence it complies with the requirements.

Also monitoring system use the same antenna used for transmission.

3.3 Clock Frequencies

The EUT generates internally following clock frequencies:

10.368 MHz

4MHz

3.4 Independent Operation Modes

The system was configured for testing with its typical normal connection.

The justification and manipulation of cables and equipment in order to simulate a worst-case behavior of the test setup has been carried out as prescribed in ANSI C63.17: 1998.

Testing was performed at the lowest operating frequency (1921.536 MHz), the operating frequency in the middle of the specified frequency band (1924.994 MHz), the highest operating frequency (1928.448 MHz) or typical communication with digital communication tester or companion device.

3.5 Noise Suppressing Parts

Refer to schematic provided by the client.

4. Test Set-up and Operation Modes

4.1 Test Methodology

The test methodology used is based on the requirements of 47 CFR Part 15 (2007-04-05), sections 15.31, 15.33, 15.35, 15.205, 15.209.

The test methods, which have been used, are based on ANSI C63.17: 1998.
Details see under each test.

4.2 Physical Configuration for Testing

Refer to section: Photographs of the Test Set-Up

Figure 1: Test setup

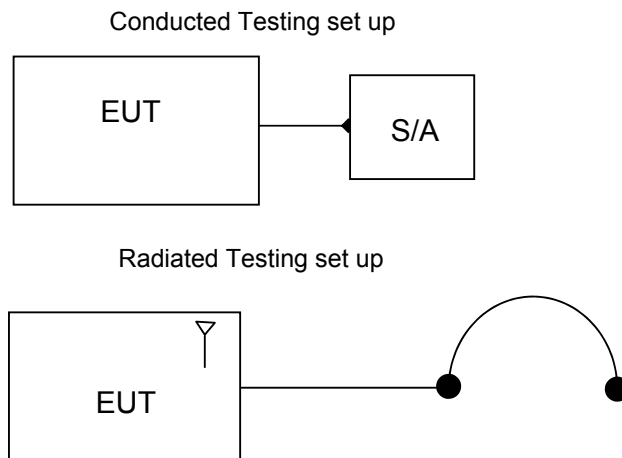

For conducted tests, the antenna was replaced by a 50Ω antenna connector.

Prüfbericht - Nr.: 12604528 003
Test Report No.:

Seite 13 von 61
Page 13 of 61

4.3 Test Operation and Test Software

Software version used for testing: N/A

The EUT had built-in test modes.

The EUT was exercised in the operation modes listed under 3.4 as appropriate.

4.4 Special Accessories and Auxiliary Equipment

The product has been tested together with the following additional accessory

1. Product: Central Module
Manufacturer: Matsushita Electric
Model: WX-C3010
Serial Number: Preproduction

2. Product: Digital Radio Communication Tester
Manufacturer: Rohde & Schwarz
Model: CMD60
Serial Number: 100185

3. Product: Digital Radio Test
Manufacturer: Rohde & Schwarz
Model: CTS60
Serial Number: 100762

Prüfbericht - Nr.: 12604528 003
Test Report No.:
Seite 14 von 61
Page 14 of 61

5. Test Results Conducted Testing At Antenna Port

For conducted tests, the antenna was replaced by a 50Ω antenna connector.

5.1.1 Conducted Output Power at Antenna Terminals FCC 15.319(c) and RSS-213 § 6.5

RESULT:
PASS

Date of testing: 2008-06-19

Ambient temperature: 24.0 °C

Relative humidity: 24 %

Atmospheric pressure: 1010hPa

Requirements:

For systems operating in the 1920-1930MHz band the maximum peak output power is 100 microwatt multiplied by the square root of the occupied bandwidth in hertz.

Test procedure:

ANSI C63.17-1998 section 6.1.2

The maximum peak output power (conducted) was measured directly (without additional cable) at the antenna connector with the spectrum analyzer following the procedure of ANSI 63.17-1998.

Table 2: Conducted output power at antenna port 0

Frequency (MHz)	Limit (dBm)	Output (dBm)	Output (mW)	Margin (dB)
1921.536	20.4	19.0	79.4	1.4
1924.994	20.4	18.9	77.6	1.5
1928.448	20.5	18.9	77.6	1.6

Figure 3: Power plots of 1924.994MHz

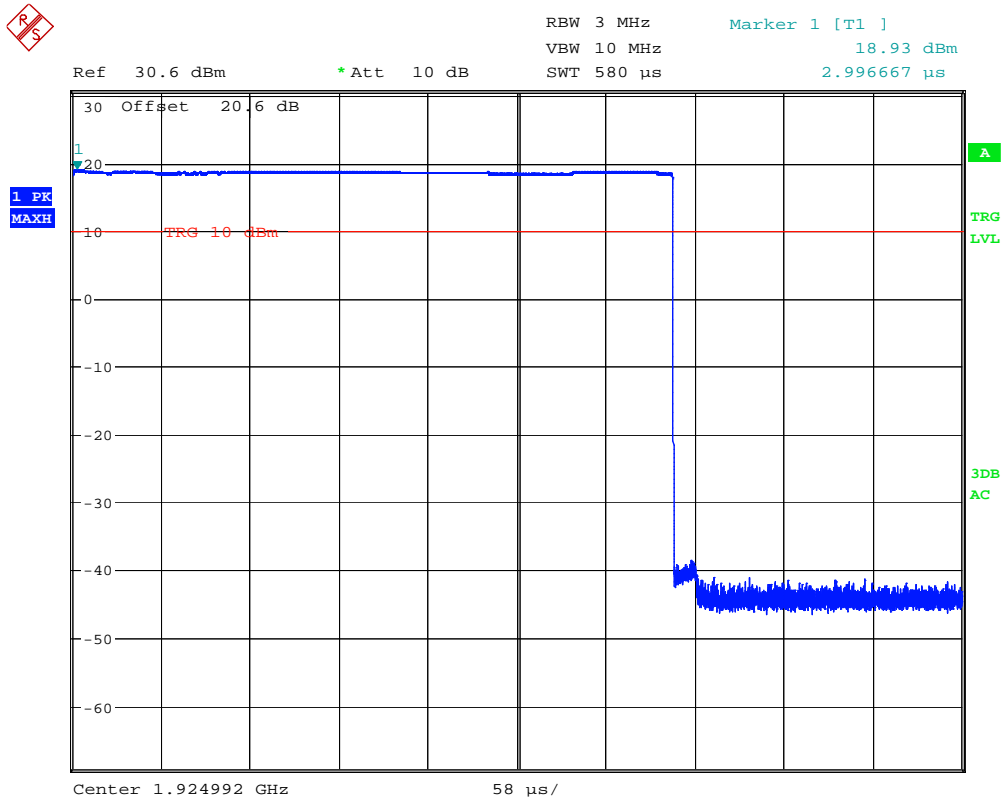

power mid channel

Date: 19.JUN.2008 17:18:49

Figure 4: Power plots of 1928.448MHz

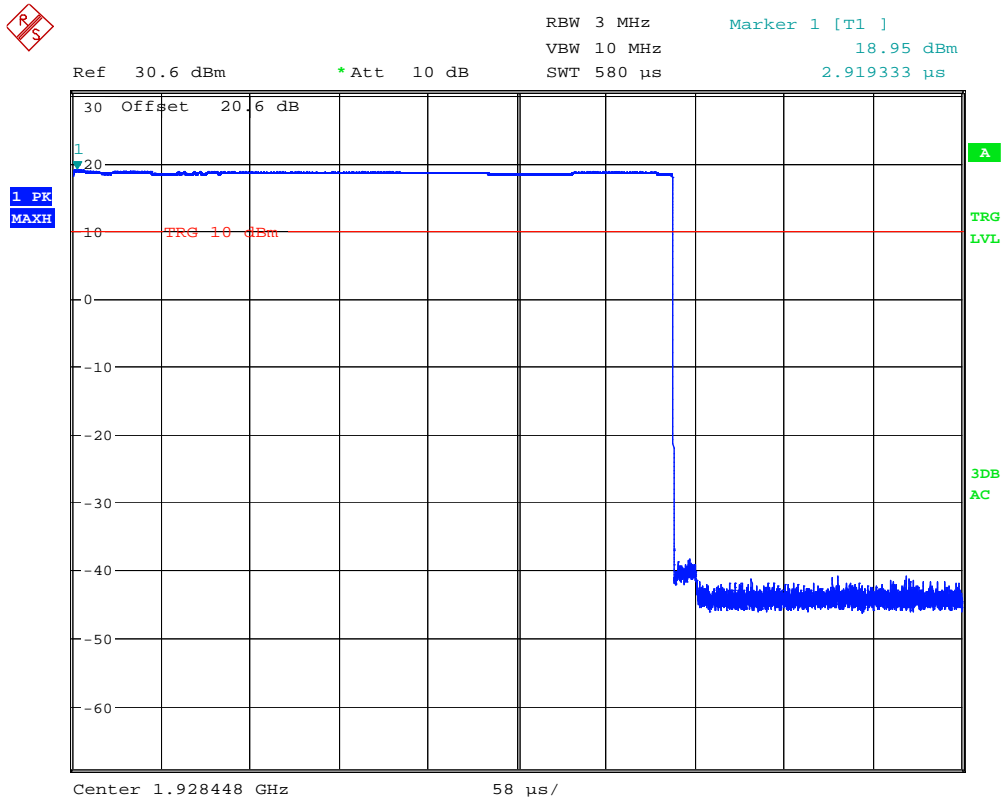

power high channel
Date: 19.JUN.2008 17:22:55

Prüfbericht - Nr.: 12604528 003
Test Report No.:
Seite 18 von 61
Page 18 of 61
5.1.2 26dB Bandwidth FCC 15.303(c),15.323(a) and RSS-213 § 6.4
RESULT:
PASS

Date of testing: 2008-06-17

Ambient temperature: 24.0 °C

Relative humidity: 24 %

Atmospheric pressure: 1010hPa

Requirements:

For systems using digital modulation in the 1920-1930MHz band the minimum 26dB bandwidth shall be at least 50 kHz and less than 2.5 MHz.

Test procedure:

ANSI C63.17-1998 section 6.1.3

The output connector is connected to a spectrum analyzer. The spectrum analyzer resolution bandwidth was set to 1% of the emission bandwidth and the spectrum analyzer center at the nominal frequency of the channel. The 26dBc(or 20 dBc) Bandwidth was measured by using the DELTA MARKER function of the analyzer.

Table 3: Bandwidth

Frequency (MHz)	Bandwidth (kHz)
1921.536	1282(26dB)
1924.994	1282(20dB)
1928.448	1298(26dB)

Figure 5: 26dB Bandwidth of 1921.536MHz

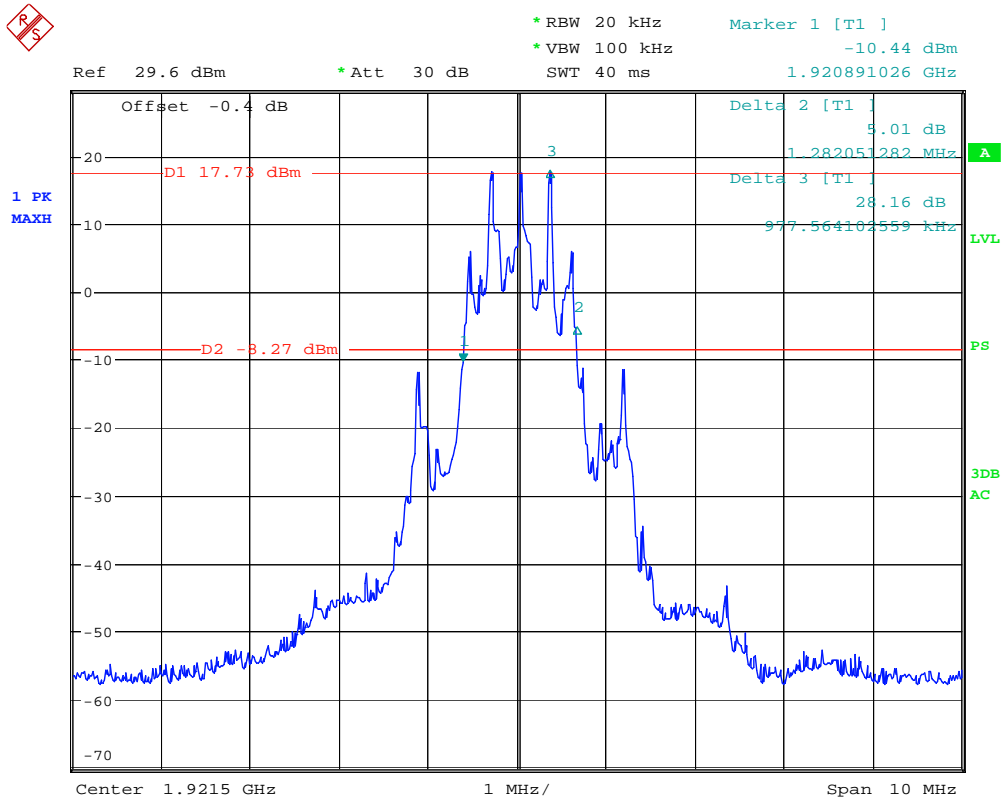

Low Channel (4)

Date: 17.JUN.2008 18:43:10

Figure 6: 20dB Bandwidth of 1924.994MHz

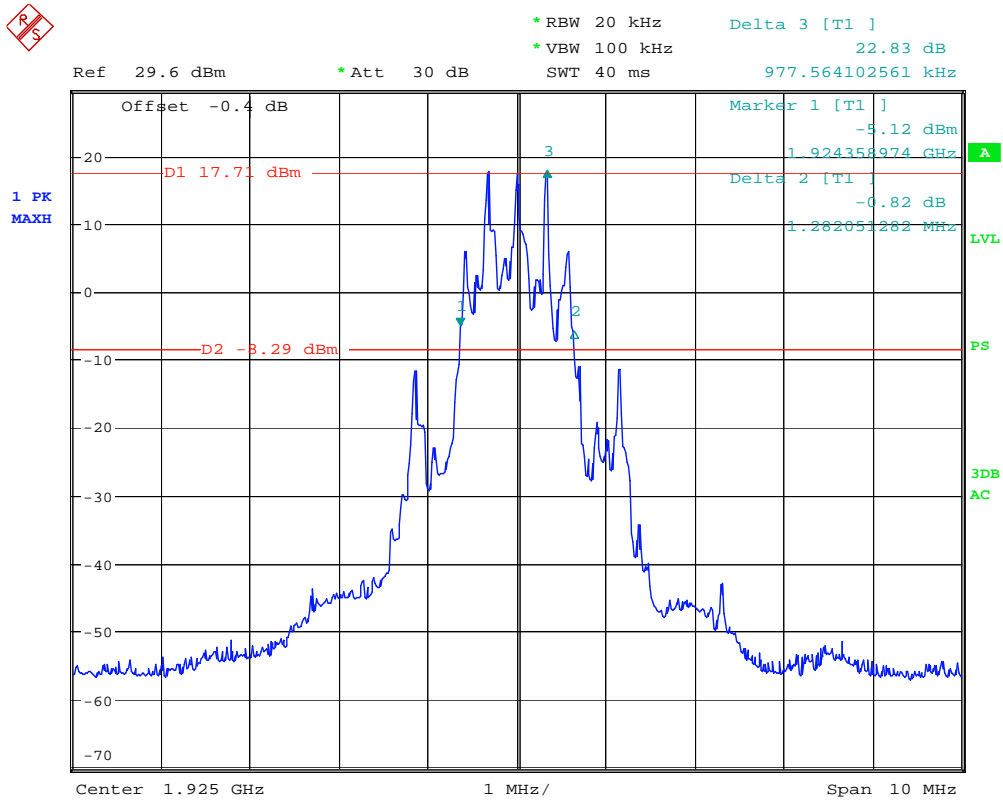

Mid Channel (2)

Date: 17.JUN.2008 18:47:51

Figure 7: 26dB Bandwidth of 1928.448MHz

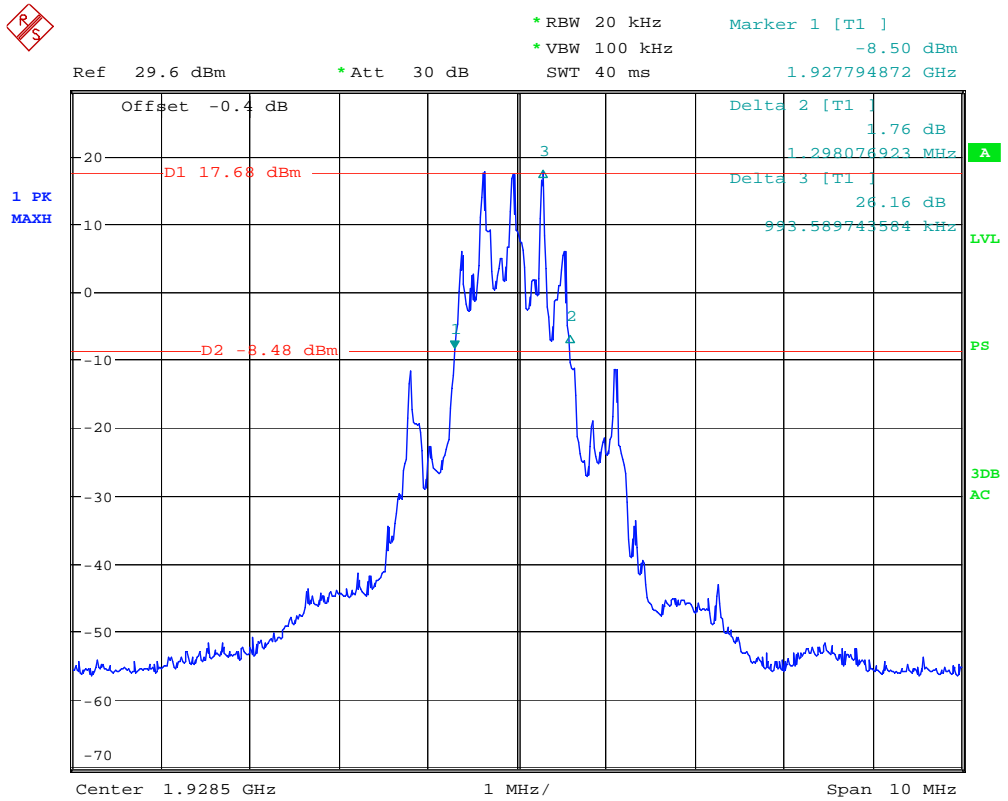

High Channel (0)

Date: 17.JUN.2008 18:35:47

Prüfbericht - Nr.: 12604528 003

Test Report No.:

Seite 22 von 61

Page 22 of 61

5.1.3 In-Band Unwanted Emissions, Emissions FCC 15.323(d) and RSS-213 §6.7.2**RESULT:****PASS**

Date of testing: 2008-06-19

Ambient temperature: 24.0 °C

Relative humidity: 24 %

Atmospheric pressure: 1010hPa

Requirements:

B<f≤2B:less than or equal to 30 dB below max. permitted peak power level

2B<f≤3B:less than or equal to 50 dB below max. permitted peak power level

3B<f≤Band Edge:less than or equal to 60 dB below max. permitted peak power level

Test procedure:

ANSI C63.17-1998 § 6.1.6.1

A spectrum analyzer was connected to the antenna port of the transmitter. For each channel investigated, the in-band measurements were performed.

Figure 8: In-band emission of 1921.536MHz

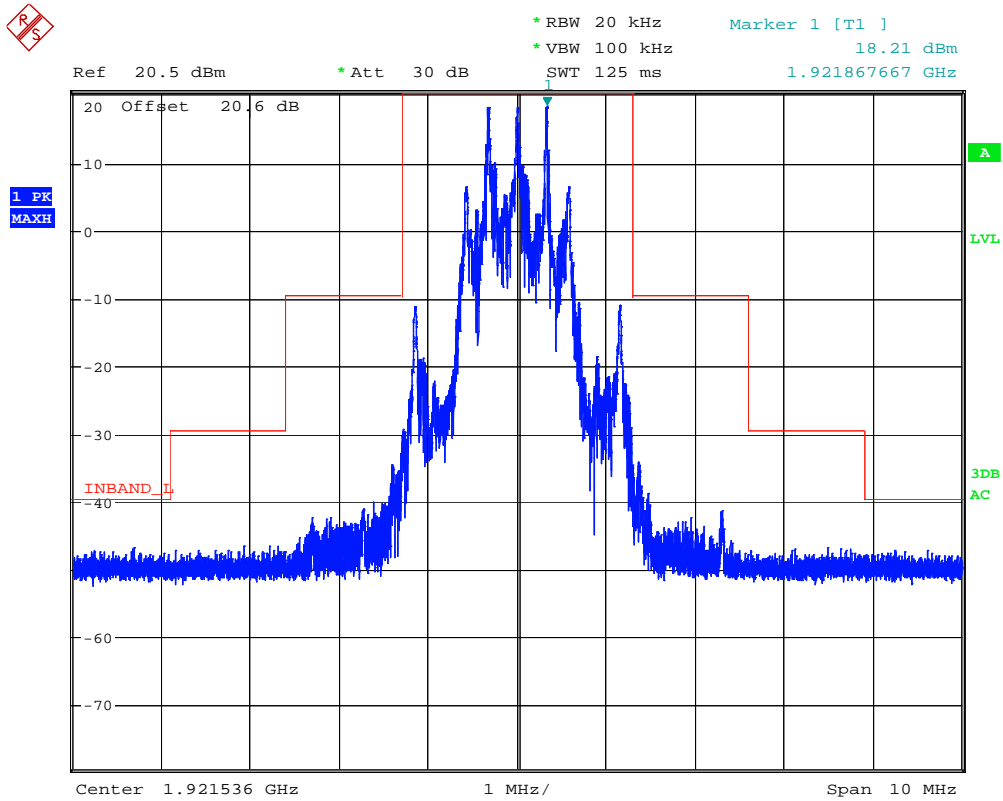

in-band emission

Date: 19.JUN.2008 20:26:21

Figure 9: In-band emission of 1928.448MHz

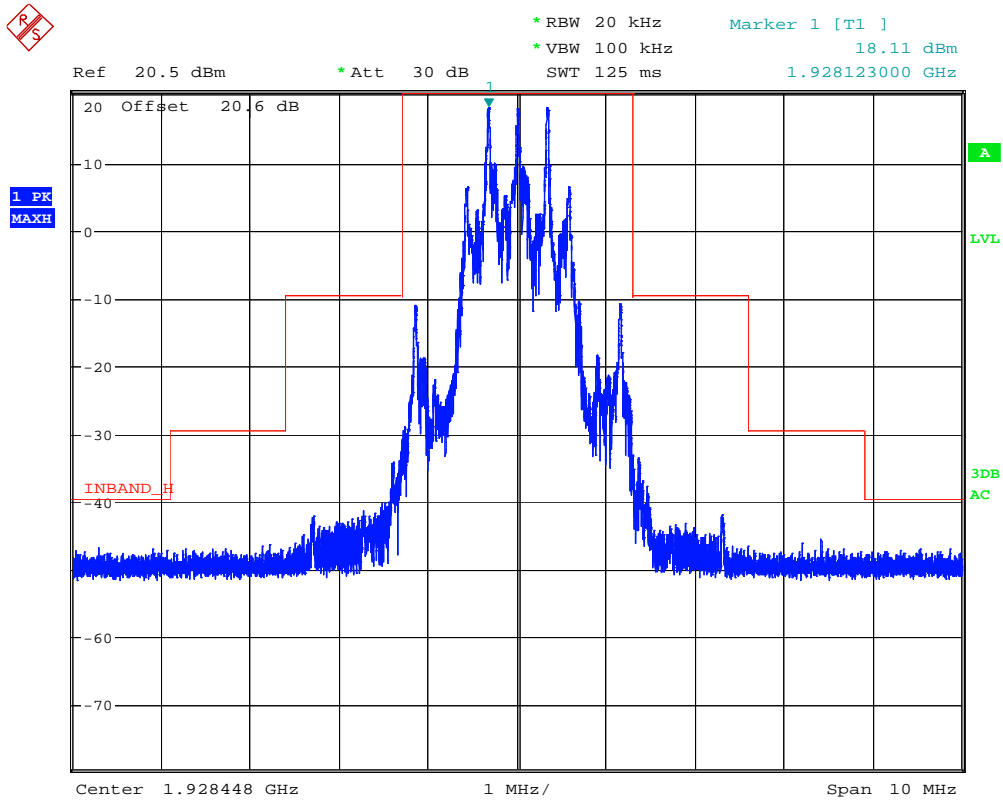

in-band emission

Date: 19.JUN.2008 20:21:27

Prüfbericht - Nr.: 12604528 003

Test Report No.:

Seite 25 von 61

Page 25 of 61

5.1.4 Out-of-Band Unwanted Emissions, Emissions FCC 15.323(d) and RSS-213 § 6.7.1**RESULT:****PASS**

Date of testing: 2008-06-19

Ambient temperature: 24.0 °C

Relative humidity: 24 %

Atmospheric pressure: 1010hPa

Requirements:

 $f \leq 1.25\text{MHz}$ outside band : limit -9.5dBm $1.25\text{MHz} \leq f \leq 2.5\text{MHz}$ outside band : limit -29.5 dBm $f \geq 2.5\text{MHz}$ outside band : limit -39.5 dBm

Test procedure:

ANSI C63.17-1998 § 6.1.6.1

A spectrum analyzer was connected to the antenna port of the transmitter. For each channel investigated, the out-of-band measurements were performed.

Figure 10: Out-of-band emission of 1921.536MHz

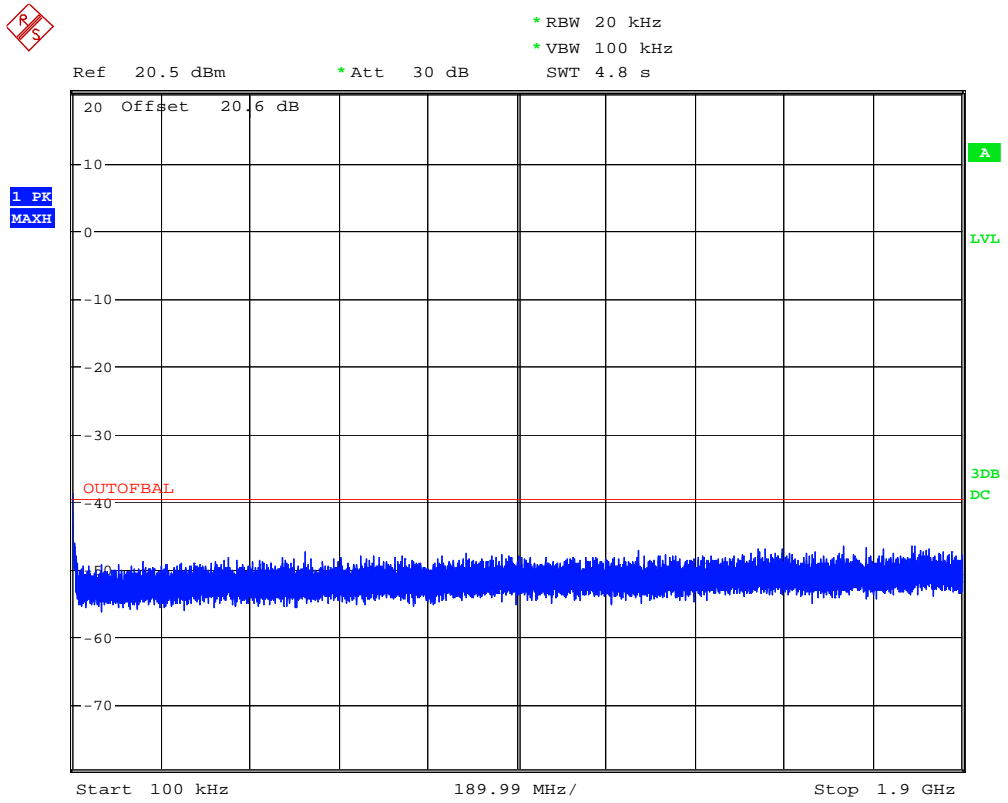

out-of-band emission
Date: 19.JUN.2008 20:32:03

Figure 11: Out-of-band emission of 1921.536MHz

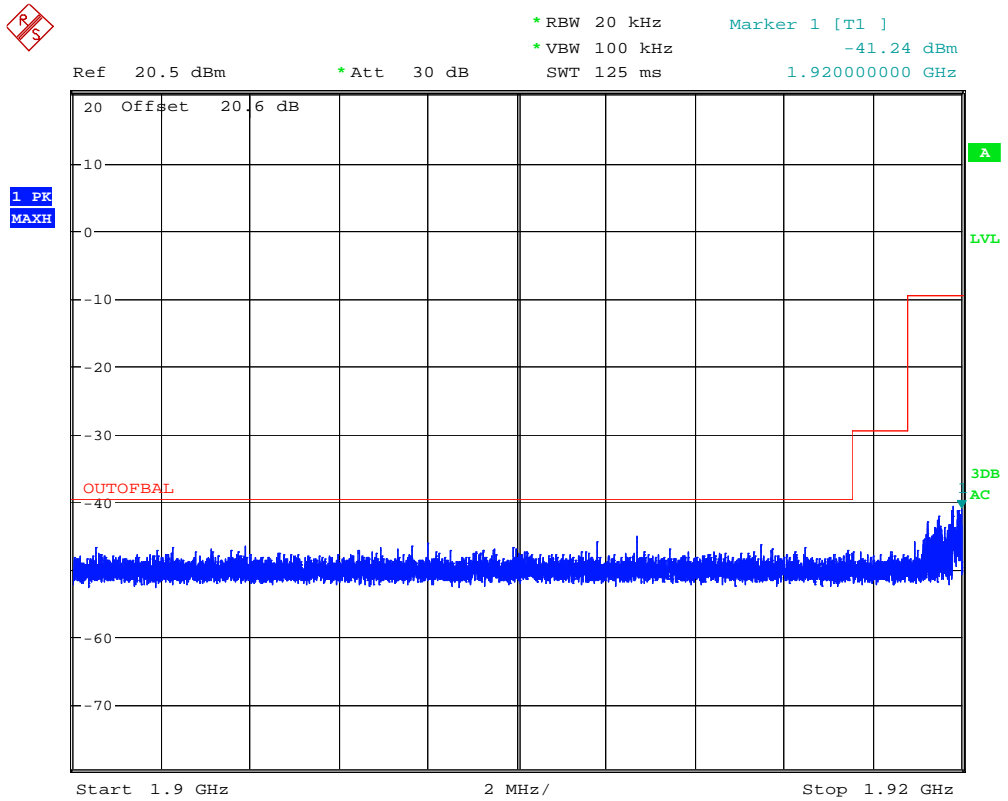

out-of-band emission
Date: 19.JUN.2008 20:29:45

Figure 12: Out-of-band emission of 1928.448MHz

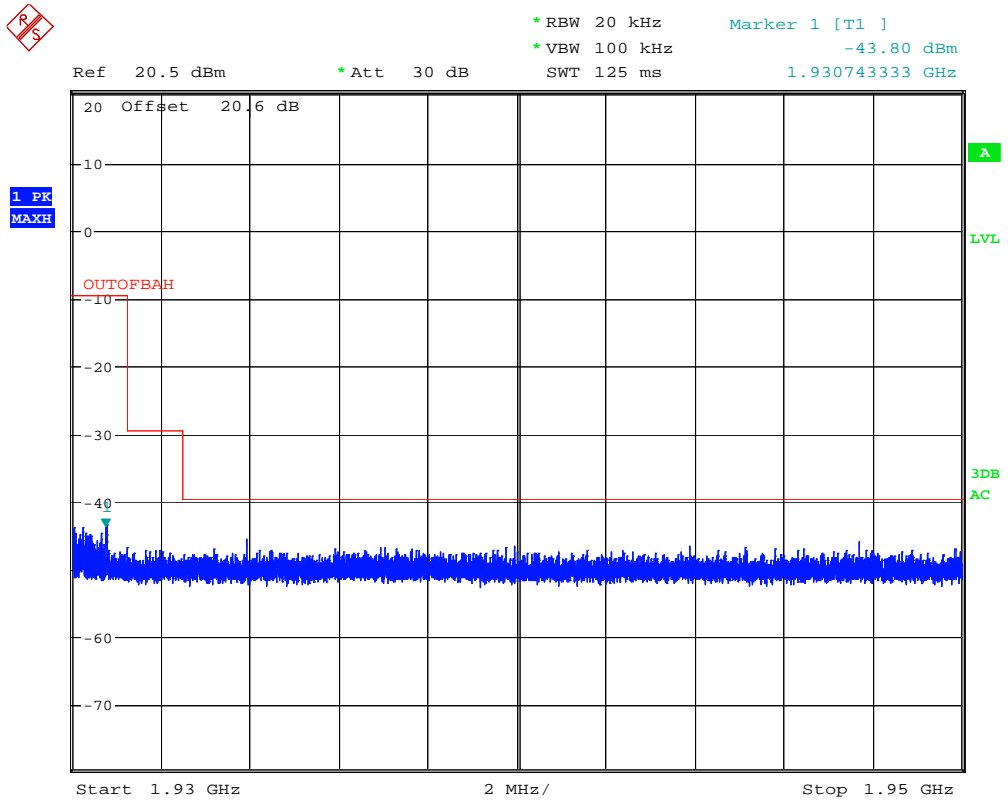

out-of-band emission
Date: 19.JUN.2008 20:35:16

Figure 13: Out-of-band emission of 1928.448MHz

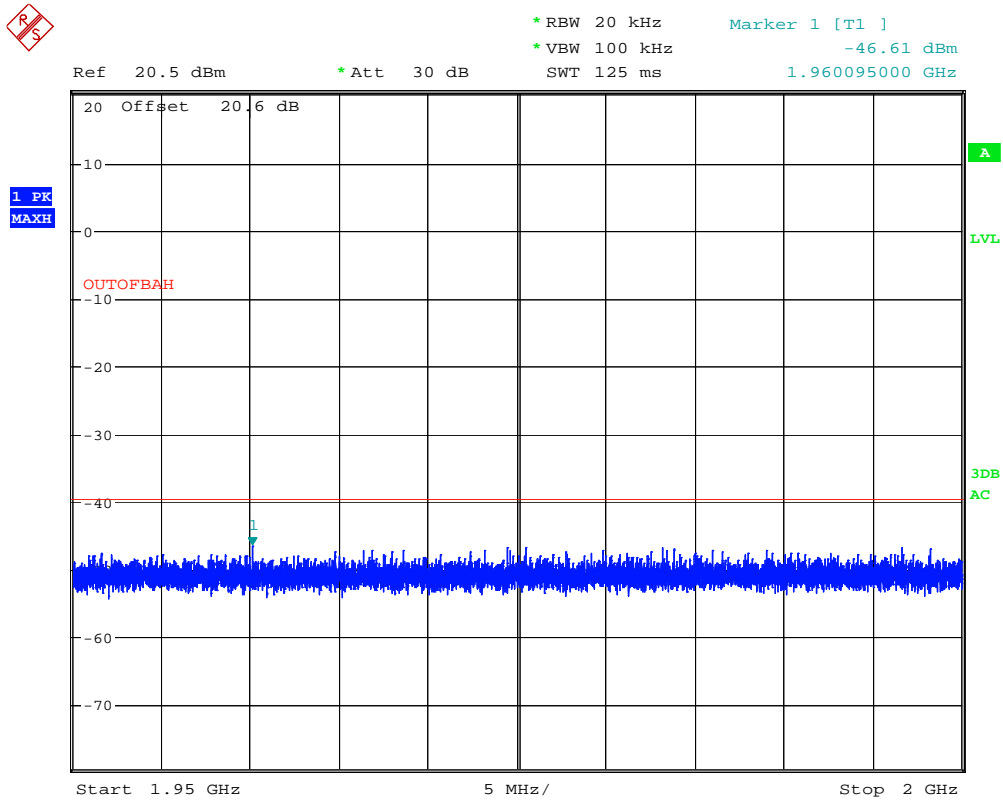

out-of-band emission
Date: 19.JUN.2008 20:36:57

Figure 14: Out-of-band emission of 1928.448MHz

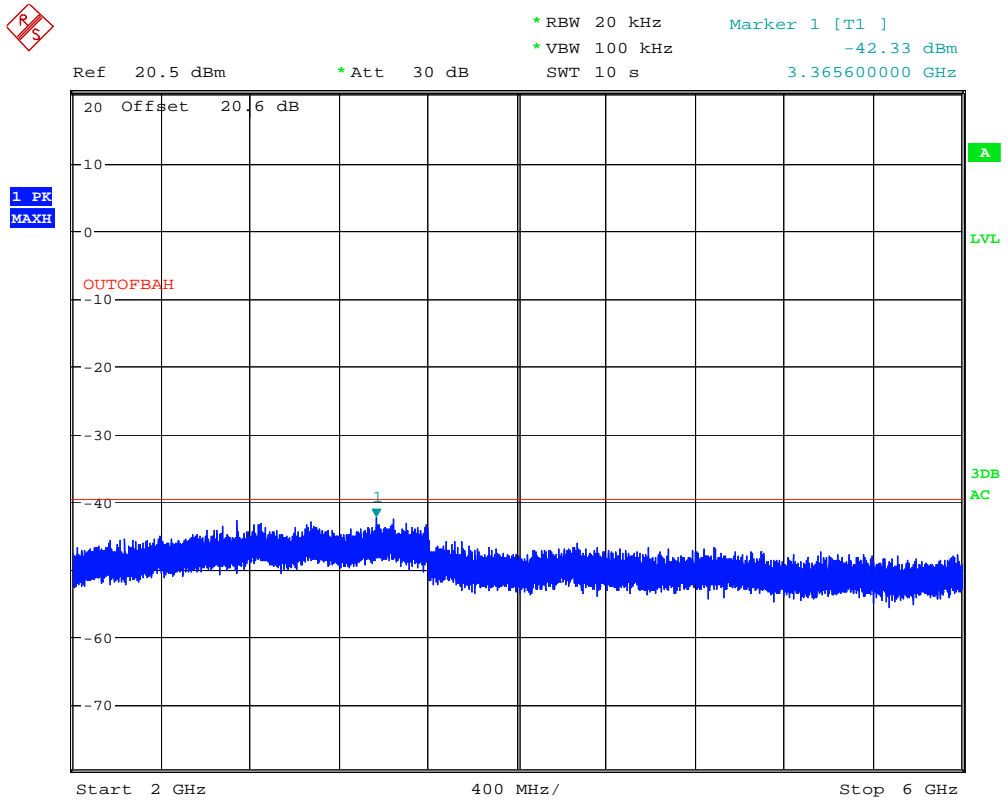

out-of-band emission
Date: 19.JUN.2008 20:38:43

Figure 15: Out-of-band emission of 1928.448MHz

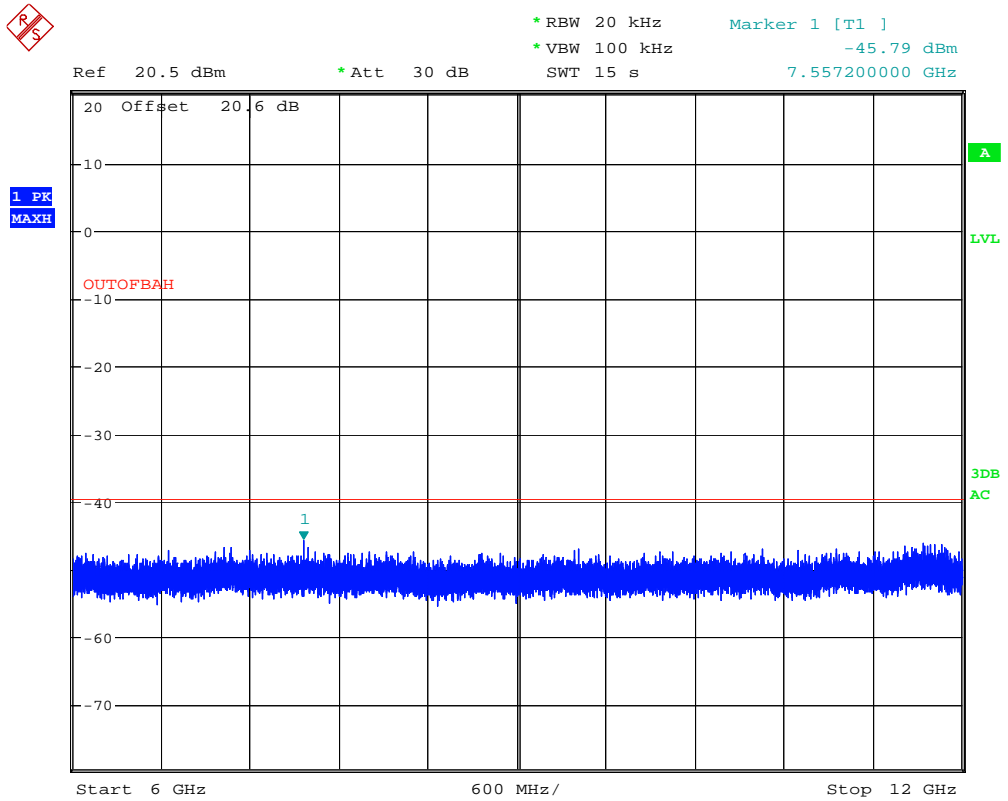

out-of-band emission

Date: 19.JUN.2008 20:40:11

Figure 16: Out-of-band emission of 1928.448MHz

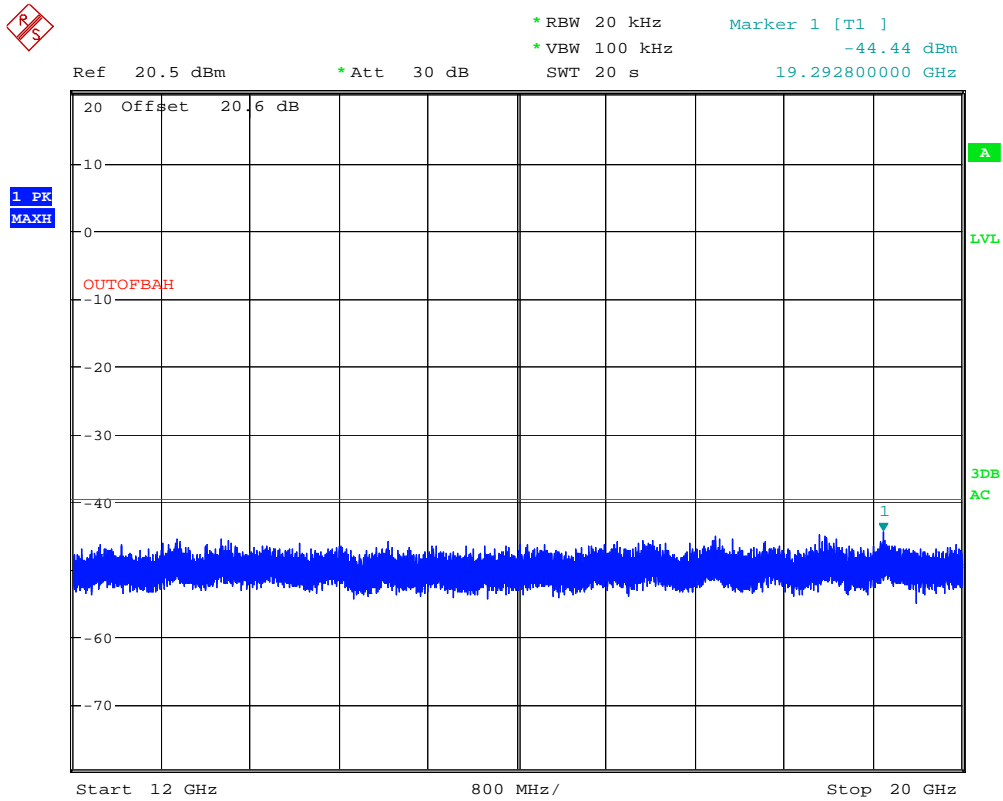

out-of-band emission

Date: 19.JUN.2008 20:41:27

Prüfbericht - Nr.: 12604528 003
Test Report No.:
Seite 33 von 61
Page 33 of 61
5.1.5 Peak Power Spectral Density FCC 15.319(d) and RSS-213 § 6.6
RESULT:
PASS

Date of testing: 2008-06-19

Ambient temperature: 24.0 °C

Relative humidity: 24 %

Atmospheric pressure: 1010hPa

Requirements:

Power spectral density shall not exceed 3 mW in any 3 kHz bandwidth as measured with a spectrum analyzer having a resolution bandwidth of 3 kHz.

Test procedure:

ANSI C63.17-1998 subclause 6.1.5 .

A spectrum analyzer was connected to the antenna port of the transmitter. Analyzer Resolution Bandwidth was set to 3 kHz. The Video Bandwidth was set to 10 kHz.

Table 4: Peak Power Spectral Density

Frequency (MHz)	Limit (dBm)	Power Density (dBm)	Margin (dB)
1921.536	4.77	-3.29	8.06
1928.448		2.74	2.03

Notes : 1) Power density = (Reading) + (Correction factor)

2) Correction factor = Cable loss

Figure 17: Power Spectral Density of 1921.536MHz

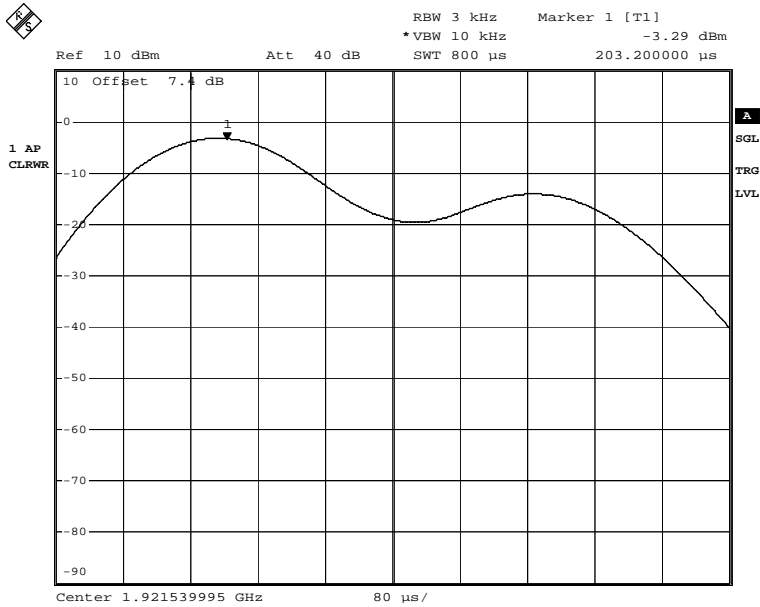

Date: 23.SEP.2008 18:03:16

Figure 18: Power Spectral Density of 1928.448MHz

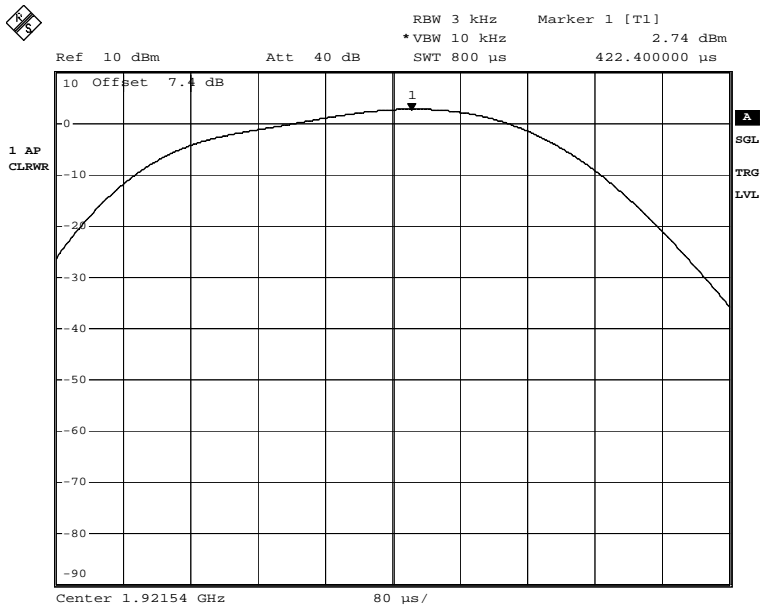

Date: 23.SEP.2008 17:46:07

Prüfbericht - Nr.: 12604528 003
Test Report No.:

Seite 35 von 61
Page 35 of 61

6. Test Results Conducted Emissions

6.1.1 Mains Terminal Continuous Disturbance Voltage FCC part 15.207

RESULT: N/A

Requirements:

The emissions from the intentional radiator shall not exceed the field strength specified in 15.207(a).

The device is battery operated therefore this test item is not applicable

6.1.2 Mains Terminal Continuous Disturbance Voltage FCC part 15.107

RESULT: N/A

Requirements:

The emissions shall not exceed the field strength specified in 15.107(a).

The device is battery operated therefore this test item is not applicable

6.1.3 Mains Terminal Continuous Disturbance Voltage FCC part 15.107

RESULT: N/A

Requirements:

The emissions shall not exceed the field strength specified in 15.107(a).

The device is battery operated therefore this test item is not applicable

Prüfbericht - Nr.: 12604528 003
Seite 36 von 61
Test Report No.:
Page 36 of 61

7. Test Results Spurious

7.1.1 Radiated Emission Receiver/Digital spurious

RESULT:
PASS

Date of testing:	2008-06-17
Ambient temperature:	24°C
Relative humidity:	57%
Atmospheric pressure:	1002hPa
Frequency range:	30MHz - 10GHz
Measurement distance:	3m
Kind of test site:	Semi Anechoic Chamber

Requirements:

The emissions from the intentional radiator shall not exceed the field strength specified in 15.109 class B and RSS-Gen Table 1.

Test procedure:

ANSI C63.4-2003, RSS-Gen 4.9, 4.10

The physical arrangement of the test system and associated cabling was varied in order to ensure that maximum emission amplitudes were attained.

Final radiated emissions measurements were made at 3meters. The EUT was placed on a nonconductive turntable 0.8 meters above the ground plane. The spectrum was examined from 9 kHz to the 5th harmonic of the highest fundamental transmitter frequency (10 GHz).

At each frequency, the EUT was rotated 360°, and the antenna was raised and lowered from 1 to 4 meters in order to determine the emission's maximum level. Measurements were taken using both horizontal and vertical antenna polarizations. For frequencies between 30 and 1000 MHz, the spectrum analyzer's 6 dB bandwidth was set to 120 kHz, and the analyzer was operated in the CISPR quasi-peak detection mode.

For emissions above 1000 MHz, emissions are measured using following settings:

Peak: RBW=1MHz, VBW=1MHz

Average: RBW=1MHz, VBW=10Hz

The highest emission amplitudes relative to the appropriate limit were recorded in this report.

The EUT was tested in the three axis, the worst cases were recorded.

Emissions other than those mentioned are small or not detectable.

Figure 19: Spectral Diagram, Radiated Emission 30MHz - 1GHz, Horizontal Antenna Orientation

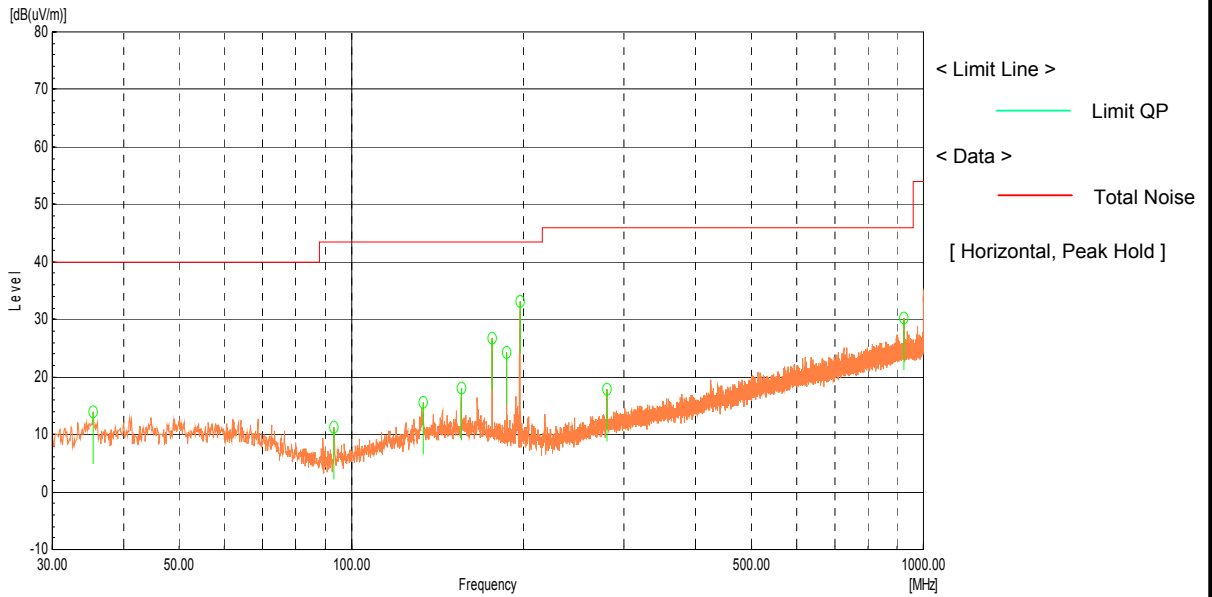
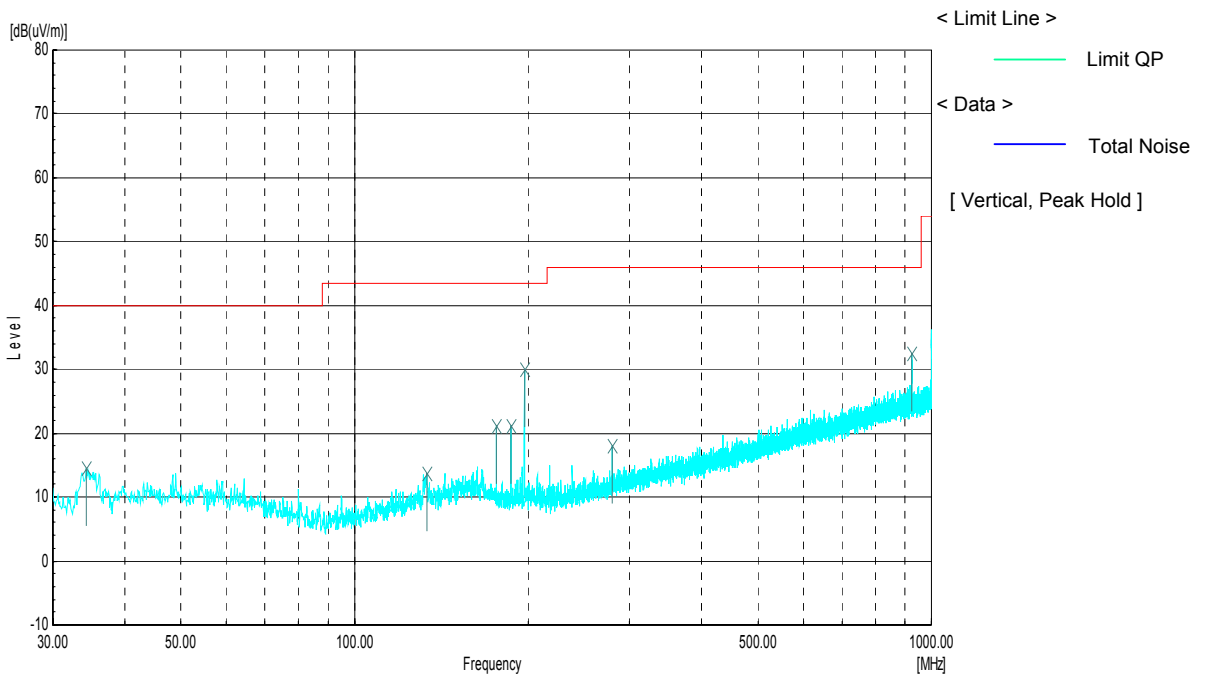

Figure 20: Spectral Diagram, Radiated Emission 30MHz - 1GHz, Vertical Antenna Orientation



Prüfbericht - Nr.: 12604528 003

Seite 38 von 61

Test Report No.:

Page 38 of 61

Table 5: Radiated Emission 30MHz - 1GHz, Horizontal & Vertical Antenna Orientations, Quasi Peak Data

Freq. [MHz]	Antenna Orientation	Result (Measured) QP [dB(μV)]	Factor [dB(1/m)]	Level QP [dB(μV/m)]	Limit [dB(μV/m)]	Margin QP [dB]	Height [cm]	Angle [°]
34.311	V	38.8	-24.3	14.5	40	25.5	100	350
35.388	H	37.9	-24	13.9	40	26.1	400	295
93.289	H	39.7	-28.4	11.3	43.5	32.2	400	326
133.456	H	39.2	-23.6	15.6	43.5	27.9	400	229
155.5	H	40.5	-22.4	18.1	43.5	25.4	400	250
176.269	H	50.3	-23.5	26.8	43.5	16.7	400	264
186.556	H	48.9	-24.7	24.2	43.5	19.3	400	288
196.941	H	58.7	-25.6	33.1	43.5	10.4	400	260
279.921	V	39.9	-21.9	18	46	28	100	56
924.368	H	40.1	-9.9	30.2	46	15.8	400	130
924.27	V	42.7	-10.1	32.6	46	13.4	100	304

Table 6: Radiated Emission Receiver 1GHz-10GHz, Horizontal & Vertical Antenna Orientations, Peak and Average Data

Freq. [MHz]	Antenna Orientation	Level AV [dB(μV/m)]	Level PK [dB(μV/m)]	Limit AV [dB(μV/m)]	Limit PK [dB(μV/m)]	Margin AV [dB]	Margin PK [dB]
1099.966	V	25.2	38.1	54.0	74.0	28.8	35.9
7741.382	V	32.5	46.9	54.0	74.0	21.5	27.1

Notes : 1) All correction factors (antenna, cable, pre-amplifier) are included in the measurement values.

2) AV: average, PK: peak

3) The peak measured value complies with the average limit hence measurement of the AV value can be omitted.

Prüfbericht - Nr.: 12604528 003
Test Report No.:
Seite 39 von 61
Page 39 of 61

8. Verification of Access Protocols

8.1.1 Automatic Discontinuation of Transmission FCC 15.319(f) and RSS-213 § 4.3.4(a)

RESULT: PASS

Date of testing: 2008-08-01

Ambient temperature: 24.0 °C

Relative humidity: 24 %

Requirements:

Section 15.319(f)

The device shall automatically discontinue transmission in case of either absence of information to transmit or operational failure. These provisions are not intended to preclude transmission of control and signaling information or use of repetitive codes used by certain digital technologies to complete frame or burst intervals.

Test procedure:

The following tests simulate the reaction of the EUT in case of either absence of information to transmit or operational failure after a connection with the companion device is established. This may be met by reference to relevant portions of the DECT standards.

The following tests are performed after a connection is first established between the EUT and its companion device.

Table 7: Test case operational failure requirement

Test	EUT Reaction	Verdict
1 Remove Power from companion device.	A	PASS
2 Switch off the companion device.	A	PASS
3 Terminate call at the companion device.	A	PASS
4 Switch off the EUT.	A	PASS
5 Terminate call at the EUT	A	PASS
1 Remove Power from companion device.	A	PASS

A – Connection is terminated and transmission ceases.

B – Connection is terminated but the EUT transmits control or signaling information

C – Connection is terminated but the companion device transmits control or signaling information

N/A - Not Applicable (the EUT does not have an on/off switch and can not perform Hook-

Prüfbericht - Nr.: 12604528 003
Test Report No.:

Seite 40 von 61
Page 40 of 61

8.1.2 Listen before transmit FCC 15.323(c)

RESULT:

PASS

Requirements:

Section 15.323(c)

Requirements for isochronous devices operating in the UPCS sub-band.

Test procedure:

This requirement is met as shown in section 8.1.4 to 8.1.16.

Prüfbericht - Nr.: 12604528 003

Seite 41 von 61

Test Report No.:

Page 41 of 61

8.1.3 Monitoring Time FCC 15.323(c)(1) and RSS-213 § 4.3.4(b)

RESULT:**PASS**

Date of testing: 2008-07-09

Ambient temperature: 24.0 °C

Relative humidity: 24 %

Requirements:

§ 15.323(c)(1)

Immediately prior to initiating transmission, devices must monitor the combined time and spectrum windows in which they intend to transmit for a period of at least 10 milliseconds for systems designed to use a 10 milliseconds or shorter frame period or at least 20 milliseconds for systems designed to use a 20 milliseconds frame period.

Test procedure:

ANSI C63.17-1998 subclause 7.5.

Description	EUT status	Result
Apply interference at frequency F_1 at level T_u and no interference F_2 . Communication is initiate and verify the EUT transmits at F_2	EUT transmits at F_2	Pass
Apply interference at frequency F_2 at level T_u and interference remove from F_1 . Communication is initiate at least 20 ms after the interference at F_2 is active verify the EUT transmits at F_1 .	EUT transmits at F_1	Pass

Prüfbericht - Nr.: 12604528 003

Seite 42 von 61
Page 42 of 61

Test Report No.:

**8.1.4 Monitoring Threshold, Least Interfered Channel FCC
15.323(c)(2)(5) and RSS-213 § 4.3.4(b)**

RESULT: PASS

Date of testing: 2008-07-09

Ambient temperature: 24.0 °C

Relative humidity: 24 %

Monitoring Threshold Limits:

Lower Threshold:

$TL = 15 \log B - 184 + 30 - PEUT$ (dBm)

Upper Threshold:

$TU = 15 \log B - 184 + 50 - PEUT$ (dBm)

B is measured Emission Bandwidth in Hz

PEUT is measured Transmitter Power in dBm

Value Calculated

Lower Threshold	-81.2
Upper Threshold	-61.2

Requirements:

The Lower Threshold is applicable for systems which have defined less than 40 duplex system access channels. The Upper Threshold is applicable for systems with more than 40 duplex system access channels and that implements the Least Interfered Channel Procedure (LIC).

Test procedure:

ANSI C63.17-1998 subclause 7.3.2.

Table 8: Lower and Upper Threshold

Least Interfered Channel Procedure NOT used:	
Lower Threshold	-82.5 dBm
Least Interfered Channel Procedure	
Upper Threshold	-62.4 dBm

Table 9: Least Interfered Channel (LIC) Procedure Test

ANSI C63.17	Observation	Verdict
b) F_1 $T_L + 13$ dB F_2 at $T_L + 6$ dB	Transmission always on F_2	Pass
c) F_1 $T_L + 6$ dB F_2 at $T_L + 13$ dB	Transmission always on F_1	Pass
d) F_1 $T_L + 7$ dB F_2 at T_L	Transmission always on F_2	Pass
e) F_1 T_L F_2 at $T_L + 7$ dB	Transmission always on F_1	Pass

Prüfbericht - Nr.: 12604528 003

Seite 43 von 61
Page 43 of 61

Test Report No.:

**8.1.5 System Acknowledgment and Maximum Transmit Period
15.323(c)(3)(4) and RSS-213 § 4.3.4(b)**

RESULT: PASS

Date of testing: 2008-08-06

Ambient temperature: 24.0 °C

Relative humidity: 24 %

Requirements:

15.323(c)(3): Occupation of the same combined time and spectrum windows by a device or group of cooperating devices continuously over a period of time longer than 8 hours is not permitted without repeating the access criteria.

15.323(c)(4): Once access to specific combined time and spectrum windows is obtained an acknowledgement from a system participant must be received by the initiating transmitter within one second or transmission must cease.

Periodic acknowledgements must be received at least every 30 seconds or transmission must cease. Channels used exclusively for control and signaling information may transmit continuously for 30 seconds without receiving an acknowledgement, at which time the access criteria must be repeated.

Test procedure:

Acknowledgments: ANSI C63.17-1998 subclause 8.2.1

Transmission duration: ANSI C63.17-1998 subclause 8.2.2

During the initial transmission, the time/spectrum from the EUT to the companion device is monitored via a spectrum analyzer.

Table 10: Acknowledgments

ANSI C63.17	Observation	Verdict
Initial transmission without acknowledgements	<1s	Pass
Transmission time after loss of acknowledgements	5.7s	Pass

Table 11: Transmission Duration

ANSI C63.17	Observation	Verdict
Transmission duration on same time and spectrum window	10 min	Pass

Figure 21: Acknowledgments plots

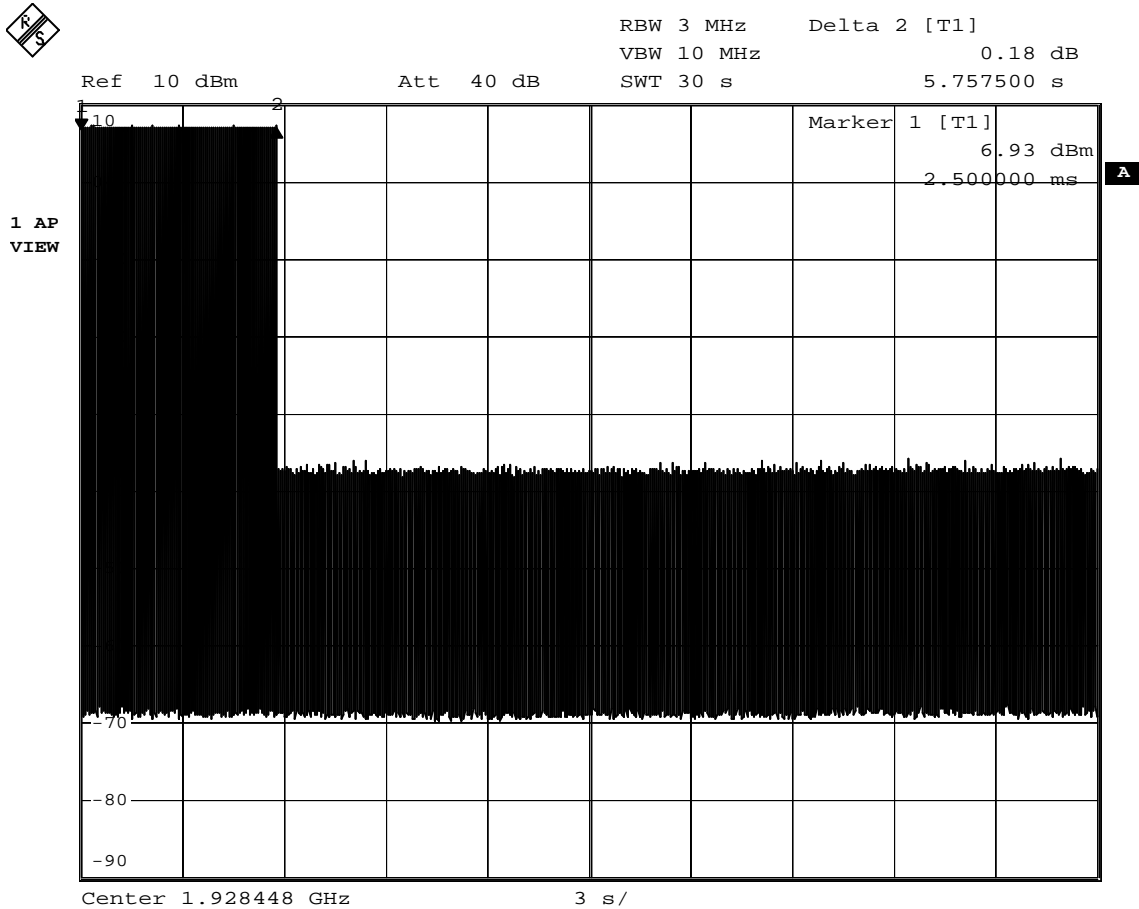

Comment A: acknowledgement for belt clip test
Date: 6.AUG.2008 19:11:36

Prüfbericht - Nr.: 12604528 003*Test Report No.:*

Seite 45 von 61

*Page 45 of 61***8.1.6 Channel Confirmation Period 15.323(c)(5) and RSS-213 § 4.3.4(b)****RESULT:****PASS**

Requirements:

15.323(c)(5): A device utilizing the provisions of this paragraph shall have monitored all access channels defined for its system within the last 10 s and shall verify, within the 20 ms (40 ms for devices designed to use a 20 ms frame period) immediately preceding actual channel access, that the detected power of the selected time and spectrum windows is no higher than the previously detected value.

Test procedure:

ANSI C63.17-1998 subclause 7.3.2.1

Refer to the test item Monitoring time and Least Interfered Channel section 8.1.15 and 8.1.5.

Prüfbericht - Nr.: 12604528 003*Test Report No.:*

Seite 46 von 61

*Page 46 of 61***8.1.7 System Acknowledgment and Maximum Transmit Period
15.323(c)(5) and RSS-213 § 4.3.4(b)(5)****RESULT:****PASS**

Requirements:

15.323(c)(5): The power measurement resolution for this comparison must be accurate to within 6 dB.

Test procedure:

ANSI C63.17-1998 subclause 7.3.2.1

The power measurement resolution for the testing performed according to part 15.323(c)(5) was accurate by at least 6dB.

Prüfbericht - Nr.: 12604528 003

Test Report No.:

Seite 47 von 61

Page 47 of 61

8.1.8 Segment Occupancy 15.323(c)(5) and RSS-213 § 4.3.4(b)(5)**RESULT:****PASS**

Requirements:

15.323(c)(5): No device or group of cooperating devices located within 1 meter of each other shall occupy more than three 1.25 MHz channels during any frame period.

RSS-213 § 4.3.4(b)(5): No device or group of cooperating devices located within 1 meter of each other shall during any frame period occupy more than 6 MHz of aggregate bandwidth, or alternatively, more than one third of the time and spectrum windows defined by the system.

Test procedure:

Declaration from client: The device complies with the DECT standards issued by ETSI, EN 300 175-2 and EN 300 175-3. Therefore during any frame period, the cooperating devices will not occupy more than one channel bandwidth.

Prüfbericht - Nr.: 12604528 003

Test Report No.:

Seite 48 von 61

Page 48 of 61

8.1.9 Random Waiting 15.323(c)(6) and RSS-213 § 4.3.4(b)(6)**RESULT:****N/A**

Requirements:

15.323(c)(6): If the selected combined time and spectrum windows are unavailable, the device may either monitor and select different windows or seek to use the same windows after waiting an amount of time, randomly chosen from a uniform random distribution between 10 and 150 milliseconds, commencing when the channel becomes available.

Test procedure:

ANSI C63.17-1998 subclause 8.1.3

The option describe in part 15.323(c)(6) is not available on the EUT.

Prüfbericht - Nr.: 12604528 003
Test Report No.:
Seite 49 von 61
Page 49 of 61
8.1.10 Monitoring Bandwidth 15.323(c)(7) and RSS-213 § 4.3.4(b)(7)
RESULT:
N/A
Requirements:

15.323(c)(7): The monitoring system bandwidth must be equal to or greater than the emission bandwidth of the intended transmission and have a maximum reaction time less than $50 \times \text{SQRT}$ ($1.25 / \text{emission bandwidth in MHz}$) microseconds for signals at the applicable threshold level but shall not be required to be less than 50 microseconds.

RSS-213 § 4.3.4(b)(7): The monitoring system bandwidth must be equal to or greater than the occupied bandwidth of the intended transmission. Note: Testing of the monitoring system bandwidth is not required if the designed bandwidth from the manufacturer is available and given in the test report.

Test procedure:

ANSI C63.17-1998 subclause 7.4

The monitoring is done via the base station used with the EUT to communicate.

Table 12: Monitoring Bandwidth

ANSI C63.17	Observation	Verdict
Simple Compliance test	N/A	Pass
More Detailed Test, at -6 dB points	N/A	N/A
More Detailed Test, at -12 dB points	N/A	N/A

Note:

- Test was performed with the level at upper level threshold+ 4dB
- The tested EUT uses the same receiver for monitoring and communication, this test is therefore not required. However the test has been performed nonetheless and the test is passed.

Prüfbericht - Nr.: 12604528 003
Test Report No.:

Seite 50 von 61
Page 50 of 61

8.1.11 Monitoring Reaction Time 15.323(c)(7) and RSS-213 §4.3.4(b)(7)

RESULT: PASS

Date of testing: 2008-07-27

Ambient temperature: 24.0 °C

Relative humidity: 24 %

Requirements:

15.323(c)(7): The monitoring system bandwidth must be equal to or greater than the emission bandwidth of the intended transmission and have a maximum reaction time less than $50 \times \text{SQRT}(1.25/\text{emission bandwidth in MHz})$ microseconds for signals at the applicable threshold level but shall not be required to be less than 50 microseconds. If a signal is detected that is 6 dB or more above the applicable threshold level, the maximum reaction time shall be $35 \times \text{SQRT}(1.25/\text{emission bandwidth in MHz})$ microseconds but shall not be required to be less than 35 microseconds.

Test procedure:

ANSI C63.17-1998 subclause 7.5

Table 13: Monitoring Reaction Time

Pluse width ANSI C63.17	Observation	Verdict
largest of 50 μ s or $50 \times \text{SQRT}(1.25/B)$	No transmission	Pass
largest of 35 μ s or $35 \times \text{SQRT}(1.25/B)$, and with interference level raised 6 dB	No transmission	Pass

Prüfbericht - Nr.: 12604528 003

Test Report No.:

Seite 51 von 61

Page 51 of 61

**8.1.12 Monitoring Threshold Relaxation 15.323(c)(9) and RSS-213
§4.3.4(b)(9)****RESULT:****N/A**

Requirements:

15.323(c)(9): Devices that have a power output lower than the maximum permitted under this subpart may increase their monitoring detection threshold by one decibel for each one decibel that the transmitter power is below the maximum permitted.

Test procedure:

ANSI C63.17-1998 subclause 4

EUT could increase the upper threshold by 1 dB based on a maximum rated transmit power found in table 2.

Prüfbericht - Nr.: 12604528 003

Test Report No.:

Seite 52 von 61

Page 52 of 61

8.1.13 Duplex System LBT 15.323(c)(10) and RSS-213 §4.3.4(b)(10)**RESULT:****N/A**

Requirements:

15.323(c)(10): An initiating device may attempt to establish a duplex connection by monitoring both its intended transmit and receive time and spectrum windows.

If both the intended transmit and receive time and spectrum windows meet the access criteria, then the initiating device can initiate a transmission in the intended transmit time and spectrum window. If the power detected by the responding device can be decoded as a duplex connection signal from the initiating device, then the responding device may immediately begin transmitting on the receive time and spectrum window monitored by the initiating device.

Test procedure:

ANSI C63.17-1998 subclause 8.2.3

The EUT does not contain this option

Prüfbericht - Nr.: 12604528 003

Test Report No.:

Seite 53 von 61

Page 53 of 61

**8.1.14 Alternative Monitoring Interval 15.323(c)(11) and RSS-213
§4.3.4(b)(11)****RESULT:****N/A**

Requirements:

15.323(c)(11): An initiating device that is prevented from monitoring during its intended transmit window due to monitoring system blocking from the transmissions of a co-located (within one meter) transmitter of the same system, may monitor the portions of the time and spectrum windows in which they intend to receive over a period of at least 10 milliseconds. The monitored time and spectrum window must total at least 50 percent of the 10 millisecond frame interval and the monitored spectrum must be within the 1.25 MHz frequency channel(s) already occupied by that device or co-located co-operating devices. If the access criteria is met for the intended receive time and spectrum window under the above conditions, then transmission in the intended transmit window by the initiating device may commence.

Test procedure:

ANSI C63.17-1998 subclause 8.2.4

The EUT does not contain this option

Prüfbericht - Nr.: 12604528 003
*Test Report No.:*Seite 54 von 61
Page 54 of 61**8.1.15 Fair Access 15.323(c)(12) and RSS-213 §4.3.4(b)(12)****RESULT:****N/A**

Requirements:

15.323(c)(12): The provisions of (c)(10) or (c)(11) shall not be used to extend the range of spectrum occupied over space or time for the purpose of denying fair access to spectrum to other devices.

Test procedure:

This EUT does not use any mechanisms as allowed by Part 15.323(c)(10) or (c)(11) to deny fair access to spectrum to other devices.

Prüfbericht - Nr.: 12604528 003

Seite 55 von 61

Test Report No.:

Page 55 of 61

8.1.16 Frame Period 15.323(e) and RSS-213 §4.3.4(c)

RESULT:**PASS**

Date of testing: 2008-08-08

Ambient temperature: 24.0 °C

Relative humidity: 24 %

Requirements:

15.323(e): The frame period (a set of consecutive time slots in which the position of each time slot can be identified by reference to a synchronizing source) of an intentional radiator operating in these subbands shall be 20 milliseconds or 10 milliseconds/X where X is a positive whole number. Each device that implements time division for the purposes of maintaining a duplex connection on a given frequency carrier shall maintain a frame repetition rate with a frequency stability of at least 50 parts per million (ppm). Each device which further divides access in time in order to support multiple communication links on a given frequency carrier shall maintain a frame repetition rate with a frequency stability of at least 10 ppm.

The jitter (time-related, abrupt, spurious variations in the duration of the frame interval) introduced at the two ends of such a communication link shall not exceed 25 microseconds for any two consecutive transmissions. Transmissions shall be continuous in every time and spectrum window during the frame period defined for the device.

Test procedure(Frame Repetition Stability):

ANSI C63.17-1998 subclause 6.2.3 and 6.2.4

A spectrum analyzer was used in order to determine the time duration between the rising edges of two consecutive frames over a period of at least 100 frames period. The results was use to calculate the 3X standard deviation of the frequency stability

Table 14: Frame Repetition Stability

Maximum Frame Repetition Stability (Hz/ppm)	Limit(ppm)	Verdict
< 0.0001Hz/3ppm	10	Pass

Prüfbericht - Nr.: 12604528 003

Test Report No.:

Seite 56 von 61

Page 56 of 61

Test procedure (Timing Jitter):

ANSI C63.17-1998 subclause 6.2.3 and 6.2.4

The CMD60 was logged by a computer programmed to get accurate readings over the noted time period or number of readings. The peak-to-peak difference was recorded and the mean value and deviation in ppm was calculated.

Table 15: Timing Jitter

Frame Period (ms)	Maximum Jitter(μ s)	Limit Max Jitter(μ s)	Verdict
10.0	-0.05	25	Pass

Prüfbericht - Nr.: 12604528 003

Seite 57 von 61
Page 57 of 61

Test Report No.:

8.1.17 Frequency Stability 15.323(f) and RSS-213 §6.2

RESULT: PASS

Date of testing: 2008-08-13

Ambient temperature: 24.0 °C
Relative humidity: 46 %

Requirements:

15.323(f): The frequency stability of the carrier frequency of the intentional radiator shall be maintained within +/-10 ppm over 1 hour or the interval between channel access monitoring, whichever is shorter. The frequency stability shall be maintained over a temperature variation of -20° to +50 °C at normal supply voltage. For equipment that is capable only of operating from a battery, the frequency stability tests shall be performed using a new battery without any further requirement to vary supply voltage

Test procedure:
ANSI C63.17-1998 subclause 6.2.2

Table 16: Frequency Stability

Frequency stability	Low temp-20°C	Nominal Temp	High Temp 50°C
	3 kHz	4 kHz	6 kHz
	1.5 ppm	2.0 ppm	3.0 ppm

Frequency stability	Low Voltage	High Voltage
	N/A	N/A
	N/A	N/A

Limit:±10ppm

10. List of Tables

Table 1: List of Test and Measurement Equipment.....	8
Table 2: Conducted output power at antenna port 0	14
Table 3: Bandwidth	18
Table 4: Peak Power Spectral Density.....	33
Table 5: Radiated Emission 30MHz - 1GHz, Horizontal & Vertical Antenna Orientations, Quasi Peak Data	38
Table 6: Radiated Emission Receiver 1GHz-10GHz, Horizontal & Vertical Antenna Orientations, Peak and Average Data	38
Table 7: Test case operational failure requirement	39
Table 8: Lower and Upper Threshold.....	42
Table 9: Least Interfered Channel (LIC) Procedure Test	42
Table 10: Acknowledgments.....	43
Table 11: Transmission Duration	43
Table 12: Monitoring Bandwidth	49
Table 13: Monitoring Reaction Time	50
Table 14: Frame Repetition Stability	55
Table 15: Timing Jitter	56
Table 16: Frequency Stability	57

11. List of Figures

Figure 1: Test setup.....	12
Figure 2: Power plots of 1921.536MHz.....	15
Figure 3: Power plots of 1924.994MHz.....	16
Figure 4: Power plots of 1928.448MHz.....	17
Figure 5: 26dB Bandwidth of 1921.536MHz.....	19
Figure 6: 20dB Bandwidth of 1924.994MHz.....	20
Figure 7: 26dB Bandwidth of 1928.448MHz.....	21
Figure 8: In-band emission of 1921.536MHz	23
Figure 9: In-band emission of 1928.448MHz	24
Figure 10: Out-of-band emission of 1921.536MHz	26
Figure 11: Out-of-band emission of 1921.536MHz	27
Figure 12: Out-of-band emission of 1928.448MHz	28
Figure 13: Out-of-band emission of 1928.448MHz	29
Figure 14: Out-of-band emission of 1928.448MHz	30
Figure 15: Out-of-band emission of 1928.448MHz	31
Figure 16: Out-of-band emission of 1928.448MHz	32
Figure 17: Power Spectral Density of 1921.536MHz.....	34
Figure 18: Power Spectral Density of 1928.448MHz.....	34
Figure 19: Spectral Diagram, Radiated Emission 30MHz - 1GHz, Horizontal Antenna Orientation.....	37
Figure 20: Spectral Diagram, Radiated Emission 30MHz - 1GHz, Vertical Antenna Orientation.....	37
Figure 21: Acknowledgments plots	44

Prüfbericht - Nr.: **12604528 003**
Test Report No.:

Seite 61 von 61
Page 61 of 61

12. List of Photographs

Photograph 1: Set-up for Radiated Emission, EUT Configuration, Y axis	58
Photograph 2: Set-up for Radiated Emission, EUT Configuration, X axis	59