

KANSAI ELECTRONIC INDUSTRY DEVELOPMENT CENTER

HEAD OFFICE
6-8-7 NISHITENMA
KITA-KU OSAKA 530-0047 JAPAN



Corporate Juridical Person

IKOMA TESTING LABORATORY
12128 TAKAYAMA-CHO
IKOMA-CITY NARA 630-0101 JAPAN

TEST REPORT

Report No. A-003-03-C

Date: 22 April 2003

This test report is to certify that the tested device properly complies with the requirements of:

FCC Rules and Regulations Part 90 : Private Land Mobile Radio Services.

The tests necessary to show compliance to the requirements were performed and these results met the specifications of requirement. The results of this report should not be construed to imply compliance of equipment other than that, which was tested. Unless the laboratory permission, this report should not be copied in part.

1. Applicant

Company Name : Matsushita Electric Industrial Co., Ltd. Panasonic System Solutions Company
Mailing Address : 4-3-1, TSUNASHIMA-HIGASHI, YOKOHAMA-CITY,
KANAGAWA, 223-8639 JAPAN

2. Identification of Tested Device

Type of Device : Private Land Mobile Radio Services.
Kind of Equipment Authorization : : DoC : Certification : Verification
FCC ID : ACJ9TAWX-CH2050
Device Name : All-in One Headset
Trade Name : Panasonic
Model Number : WX-CH2050
Serial Number : CC0001 : Prototype : Pre-production : Production
Date of Manufacture : April 2003

3. Test Items and Procedure

: Measurement of RF Power Output (Substitution Method)
: Modulation Characteristics
: Emission Bandwidth
: Measurement of Field Strength of Spurious Radiation (Substitution Method)
: Measurement of Spurious Emission at Antenna Terminal
: Frequency Stability Measurement

Above all tests were performed under: FCC Part 2 Sec2.1046, Sec2.1047,
Sec2.1049, Sec2.1051, Sec2.1053, Sec2.1055 and Sec2.1057.

: without deviation, : with deviation(details are found inside of this report)

4. Date of Test

Receipt of Test Sample : 8 April 2003
Condition of Test Sample : : Damage is not found on the set.
: Damage is found on the set. (Details are described in this report)
Test Completed on : 15 April 2003

Seiichi Izumi
General Manager / Ikoma Testing Laboratory

Table of Contents

| | | |
|------|------------------------------------------------------------|----|
| 0. | LABORATORY ACCREDITATION AND MEASUREMENT UNCERTAINTY | 3 |
| 0.1. | Laboratory Accreditation..... | 3 |
| 0.2. | Measurement Uncertainty | 3 |
| 1. | CERTIFICATION OF THE COMPLIANCE..... | 3 |
| 2. | GENERAL INFORMATION | 4 |
| 2.1. | Product Description | 4 |
| 2.2. | Description for Equipment Authorization | 4 |
| 2.3. | Test Facility | 4 |
| 3. | TESTED SYSTEM..... | 5 |
| 3.1. | Test Mode..... | 5 |
| 3.2. | Block Diagram of EUT System | 5 |
| 3.3. | List of EUT System | 5 |
| 4. | RF POWER OUTPUT | 6 |
| 4.1. | Reference Rule and Specification | 6 |
| 4.2. | Test Configuration | 6 |
| 4.3. | Test Procedure..... | 7 |
| 4.4. | Test Results | 8 |
| 5. | MODULATION CHARACTERISTICS..... | 9 |
| 5.1. | Reference Rule and Specification | 9 |
| 5.2. | Test Results | 9 |
| 6. | EMISSION BANDWIDTH | 11 |
| 6.1. | Reference Rule and Specification | 11 |
| 6.2. | Test Procedure..... | 11 |
| 6.3. | Test Configuration | 11 |
| 6.4. | Test Results | 12 |
| 7. | FIELD STRENGTH OF SPURIOUS RADIATION..... | 16 |
| 7.1. | Reference Rule and Specification | 16 |
| 7.2. | Test Procedure..... | 16 |
| 7.3. | Test Configuration | 17 |
| 7.4. | Photographs of EUT System Configuration | 18 |
| 7.5. | Test Results | 19 |
| 8. | FREQUENCY STABILITY MEASUREMENT..... | 20 |
| 8.1. | Reference Rule and Specification | 20 |
| 8.2. | Frequency vs Temperature Test..... | 20 |
| 8.3. | Frequency vs Voltage Test | 21 |
| 9. | USED TEST EQUIPMENTS AND CALIBRATION STATUS..... | 22 |

0. LABORATORY ACCREDITATION AND MEASUREMENT UNCERTAINTY

0.1. Laboratory Accreditation

KEC is accredited by the National Voluntary Laboratory Accreditation Program (NVLAP) for the specific scope of accreditation under Lab Code: 200207-0.

When the test report concerns with the NVLAP accreditation test, the first page of the test report is signed by NVLAP Approved Signatory accompanied by the NVLAP logo.

The report must not be used by the client to claim product endorsement by NVLAP or any agency of the U.S. Government.

0.2. Measurement Uncertainty

The result of a measurement is only an approximation or estimate of the value of a specific quantity. And thus the measurand is complete only when a statement of uncertainty is given.

KEC quotes Measurement Uncertainty (U) of +/- 4.9 dB for Radiated Emissions and
of +/- 2.2 dB for Conducted Emissions.

1. CERTIFICATION OF THE COMPLIANCE

This test report is to certify that the tested device properly complies with the requirements of FCC Rules and Regulations Part 15 Subpart B Unintentional Radiators.

KEC evaluation criteria for compliance:

The Product complies, if

the measured results are below the specification limit by a margin more than or equal

$1/2 U$ (2.5 dB) for Radiated Emissions and

U (2.2 dB) for Conducted Emissions.

2. GENERAL INFORMATION

2.1. Product Description

The Panasonic Model No. WX-CH2050 (referred as EUT in this report) is a All-in-One Headset.

(1) Technical Specification

Operating Frequency : 463.6125 – 464.3875MHz
 Type of Antenna : Internal Antenna
 Type of Emission Designator : F3E

(2) Contained Oscillator

VCO Clock : 442.2125 - 442.9875 MHz
 PLL Clock : 21.85 MHz
 CPU Clock : 4.19 MHz
 Baseband : 3.58 MHz

(3) Rated Power Supply : DC 3.7V (Li-ion Battery)

2.2. Description for Equipment Authorization

| | |
|--------------------------------------|------------------------------------------------------------------------------------------------|
| (1) Reference Rule and Specification | : FCC Rule Part 90 Private Land Mobile Radio Services |
| (2) Kind of Equipment Authorization | : <input checked="" type="checkbox"/> Certification <input type="checkbox"/> Verification |
| (3) Procedure of Application | : <input checked="" type="checkbox"/> Original Equipment <input type="checkbox"/> Modification |

2.3. Test Facility

| | |
|--------------------------------------------------------------------------------------------------------------------------------------------------------------------------------------------------------------------------------------------------------------------------------------------------------------------------------------------------------------------------------|------------------------------------------------------------------------------------------------------------------------------------|
| All tests described in this report were performed by: | |
| Name: | KANSAI ELECTRONIC INDUSTRY DEVELOPMENT CENTER (KEC) IKOMA TESTING LABORATORY |
| Open Area Test Site | <input type="checkbox"/> No.1 <input type="checkbox"/> No.3 <input checked="" type="checkbox"/> No.4 |
| Anechoic Chamber | <input type="checkbox"/> No.1 <input type="checkbox"/> No.3 |
| Shielded Room | <input type="checkbox"/> No.1 <input checked="" type="checkbox"/> No.2 <input type="checkbox"/> No.4 <input type="checkbox"/> No.5 |
| Address: | 12128, Takayama-cho Ikoma-city, Nara, 630-0101 Japan |
| <p>These test facilities have been filed with the FCC under the criteria of ANSI C63.4-1992. The KEC has been accredited by the NVLAP (Lab. Code: 200207-0) based on ISO/IEC 17025. Also the laboratory has been authorized by TUV Product Service (GER) and TUV Rheinland (GER) based on their criteria for testing laboratory (ISO/IEC 17025).</p> | |

3. TESTED SYSTEM

3.1. Test Mode

The compliance tests were performed under the following operation mode.

- Continuous Tx

[Note]

- (1) The EUT is not operated without DTMF signal from the “Center Module”. Therefore, the center module was located a distance sufficient to ensure that it does not contribute to the measured level.
- (2) In RF output power and Spurious emission measurement, the compliance tests were performed both of horizontally placed and vertically placed in EUT. As a results, the data of operation mode that produce the maximum emission were reported.

3.2. Block Diagram of EUT System

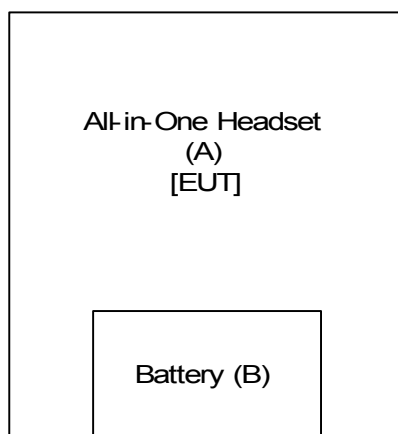

[Note]

See 3.3 List of EUT System.

3.3. List of EUT System

| No | Device Name | Model Number (Serial Number) | FCC ID (Trade Name) | Note | Remark |
|----|--------------------|---------------------------------|--------------------------------|------|--------|
| A | All-in-One Headset | WX-CH2050 (CC0001) | ACJ9TAWX-CH2050 (Panasonic) | EUT | |
| B | Battery Pack | BAT2050 (-) | N/A (Panasonic) | | |

[Attention]

N/A : Not Applicable

4. RF POWER OUTPUT

4.1. Reference Rule and Specification

FCC Rule Part 90 [Section90.217] and Part 2 Subpart J [Section2.1046],[Section2.1053]

4.2. Test Configuration

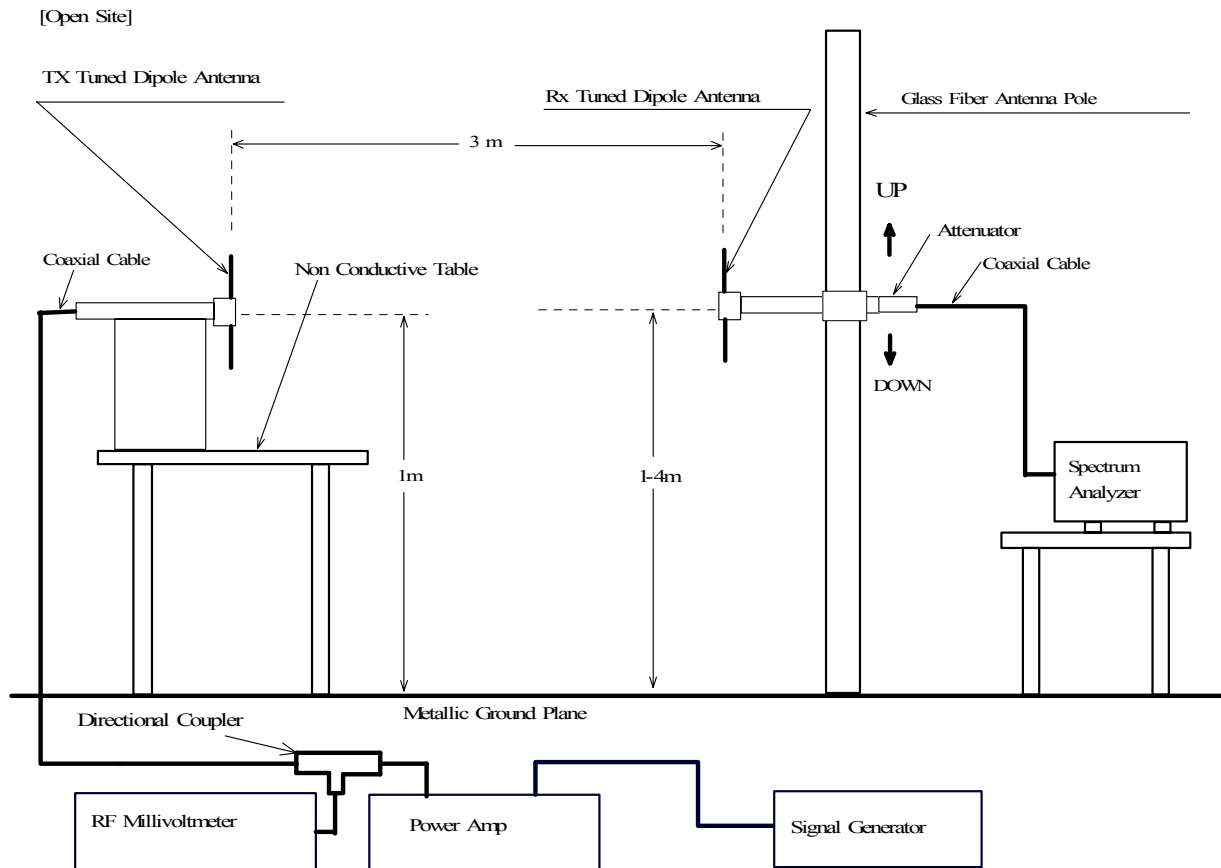

4.3. Test Procedure

- (1) Tune-up the transmitter.
- (2) The receiving antenna is adjusted to the correct length for the carrier frequency.
- (3) Raise and lower the receiving antenna to obtain a maximum reading on the Spectrum Analyzer with the antenna at horizontal polarity. Then the turntable is rotated to further increase this maximum reading. Repeat this procedure of raising and lower the antenna and rotating the turntable until the highest possible signal has been obtain. Record this maximum reading.
- (4) Repeat step3 with the antenna polarized vertically.
- (5) Remove the transmitter and replace it with the half-wave antenna. The center of these antennas are approximately at the same location as the center of the transmitter.
- (6) Feed the half-wave antenna at the transmitter end with a signal generator connected to the antenna by means of a non-radiating cable. With the antennas at both ends horizontally polarized and with the signal generator tuned to the carrier frequency, raise and lower the receiver antenna to obtain a maximum reading at the Spectrum Analyzer. Adjust the level of the signal generator output until the previous recording maximum reading for this set of conditions its obtained.
- (7) Repeat step6 with both antennas vertically polarized.

4.4. Test Results

| Measured Frequency [MHz] | Meter Reading | | Cable Loss [dB] | Carrier Power | | Maximum Carrier Power [mW] | Limit [mW] |
|-------------------------------|------------------|------------------|----------------------|------------------|------------------|---------------------------------|-----------------|
| | Hori. [dBm] | Vert. [dBm] | | Hori. [dBm] | Vert. [dBm] | | |
| 464.21 | 11.3 | 8.9 | 1.5 | 9.8 | 7.4 | 9.5 | 120.0 |

[Calculation method]

The RF Power Output can be calculated from following formula:

$$\text{RF Power (mW)} = \frac{(\text{Mr} - \text{Lo}) \div 10}{10}$$

where,

Mr: RF Meter Reading (dBm)
Lo: Loss of Cable (dB)

[Environment]

Temperature : 17 °C Humidity : 40 %

Tested Date : 9 April 2003

Tester Signature



Ikuya Minematsu

5. MODULATION CHARACTERISTICS

5.1. Reference Rule and Specification

FCC Rule Part 2 Subpart J [Section 2.1047 (a), (b)]

5.2. Test Results

(A) Overall Audio Frequency Response

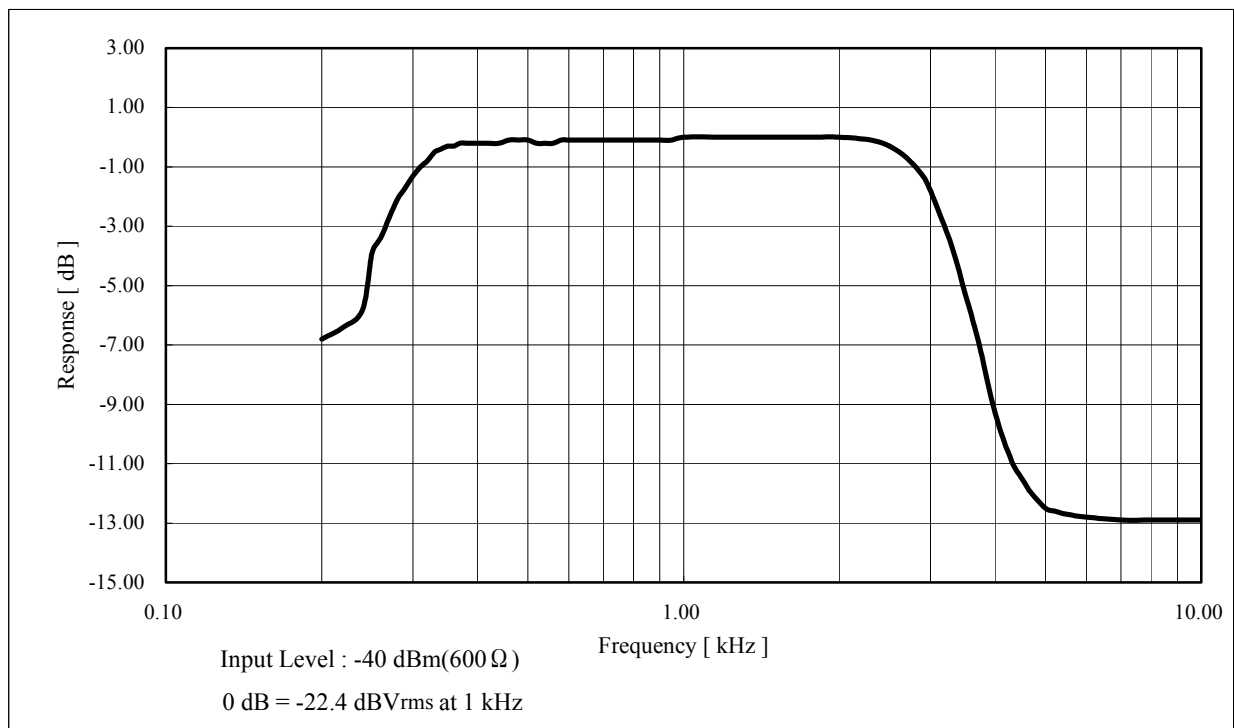

(b) Transmitter Deviation for a Range of Input Signal Level and Modulating Frequencies

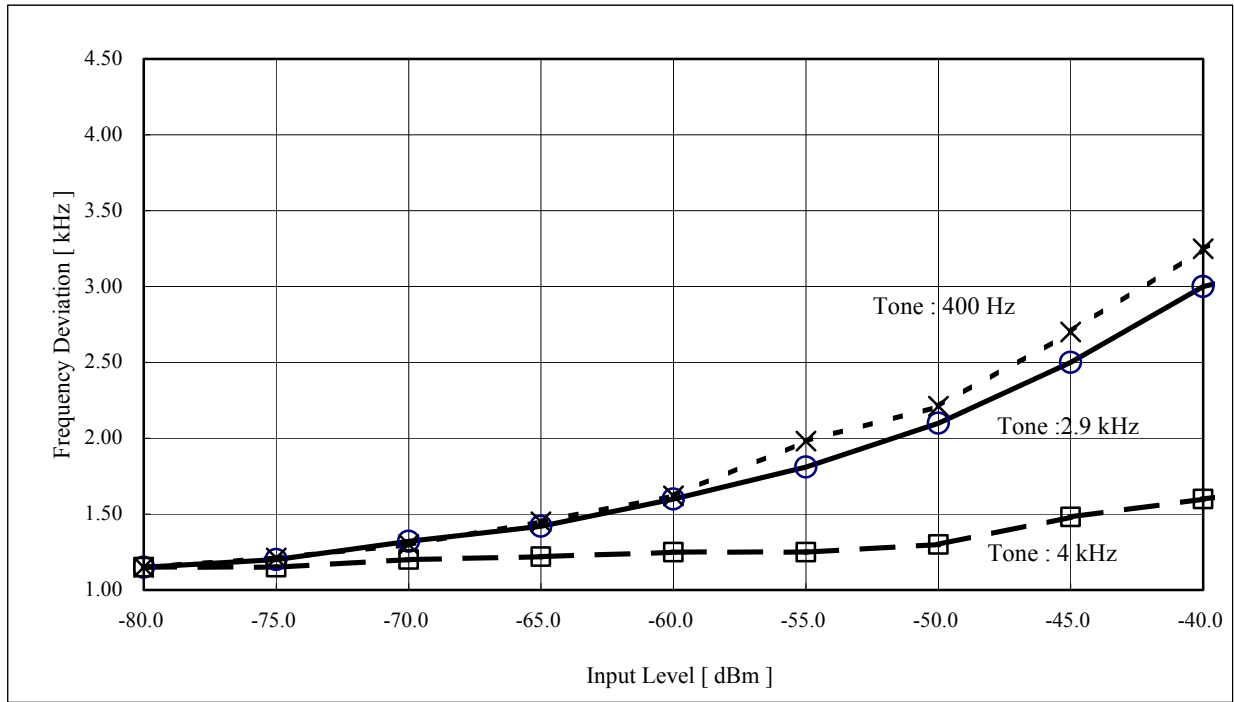

[Environment]

Temperature : 22 °C Humidity : 46 %

Tested Date : 14 April 2003

Tester Signature

Ikuya Minematsu

6. EMISSION BANDWIDTH

6.1. Reference Rule and Specification

FCC Part 2 Subpart J [Section2.1049]

6.2. Test Procedure

- (1) Set the reference level of the spectrum analyzer to the unmodulated carrier level of the EUT.
- (2) Searched maximum response of audio frequency and read maximum frequency deviation. Then set the frequency deviation to 50% and read audio input level.
- (3) Then EUT was modulated by 2.5kHz and it's level was increased 16dB.

6.3. Test Configuration

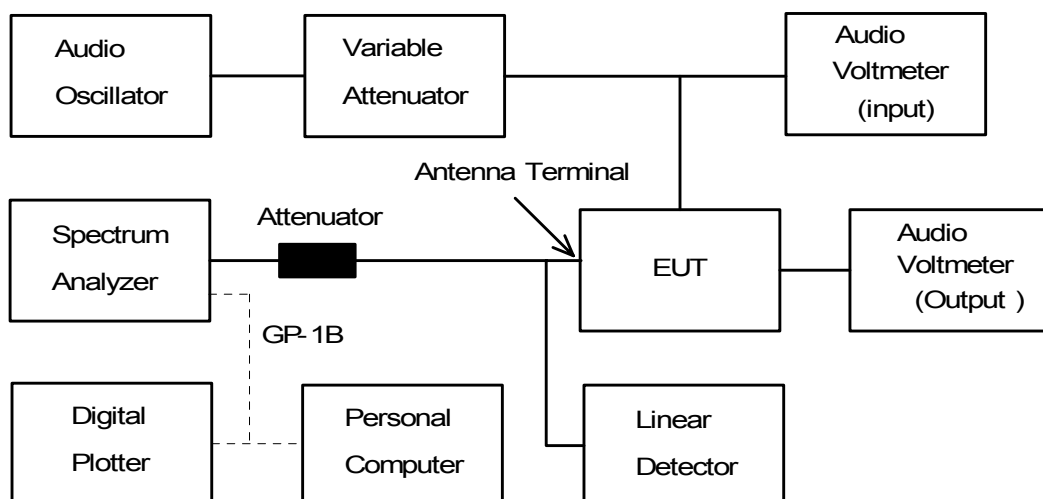

6.4. Test Results

See next figure (the picture of spectrum analyzer)

Occupied Bandwidth

The OBW was measured by the spectrum analyzer R3261B which could measure 99% occupied bandwidth (OBW).

There are 701 data on horizontal axis of display.

One of them is V_n . Then total power P can be calculated from the following formula.

$$P = \sum_{n=1}^{701} \frac{V_n^2}{R} \dots\dots\dots (1)$$

where, R is input impedance of R3261B.

Let, x is the point which gives 0.5% of the total power and Y is the point which gives 99.5% of the total power. Then we can get the following formula.

$$0.005P = \sum_{n=1}^x \frac{V_n^2}{R} \dots\dots\dots (2)$$

$$0.995P = \sum_{n=1}^y \frac{V_n^2}{R} \dots\dots\dots (3)$$

From(1)- (3), OBW becomes .

$$OBW = \frac{F_{span}(Y - X)}{700}$$

where, F_{span} is frequency span of the spectrum analyzer.

Operation Mode of EUT

Modulated by DTMF Signal.

| Ref Level | Start Frequency | Stop Frequency | Center Frequency | RBW | VBW |
|-----------|-----------------|----------------|------------------|-------|---------|
| (dBm) | MHz | (MHz) | (MHz) | (kHz) | (kHz) |
| -8.70 | 464.163 | 464.263 | 464.21 | 0.30 | 1000.00 |

| M1/M2 Point | Level | Occupied Bandwidth | Authorized Bandwidth |
|-------------|-------|--------------------|----------------------|
| (MHz) | (dBm) | (kHz) | (kHz) |
| 464.21100 | -33.9 | 3.00 | 25.00 |
| 464.21400 | -17.5 | | |

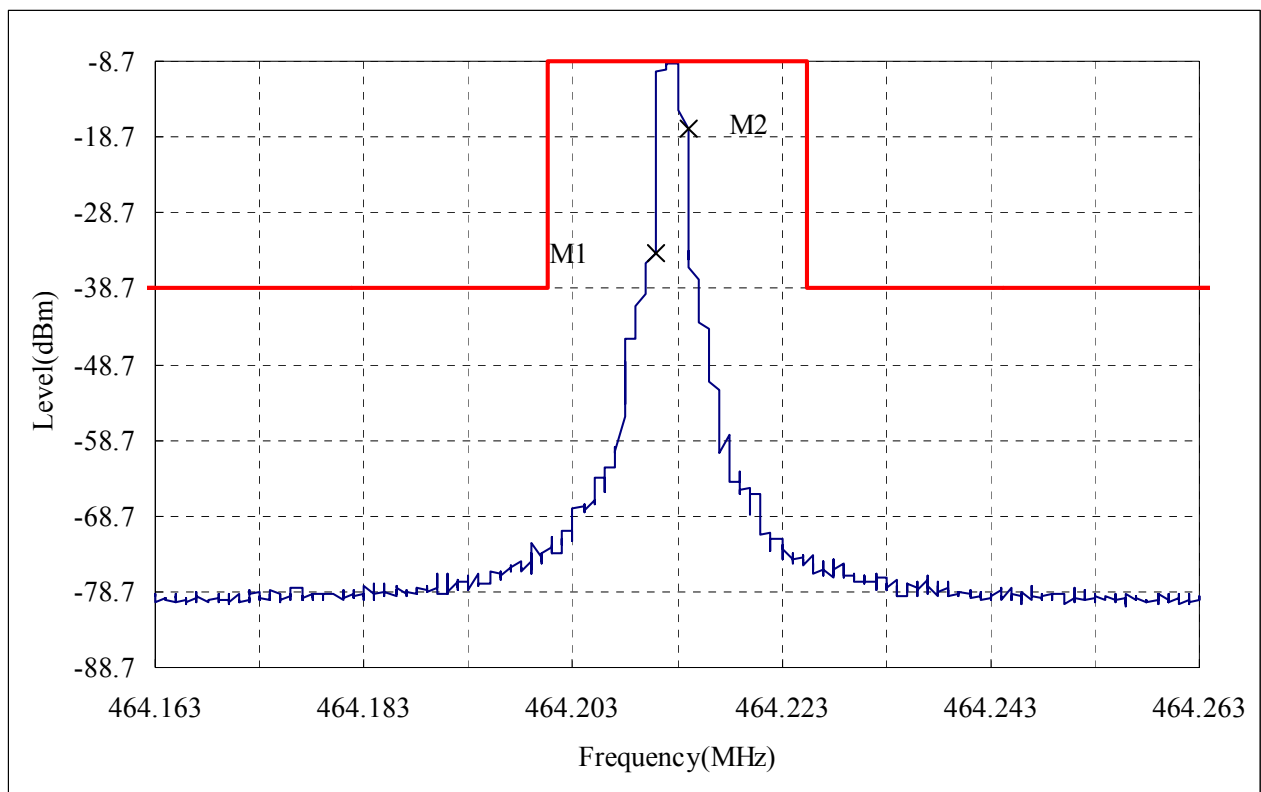

Operation Mode of EUT

Modulated by 2.5 kHz tone at input level 16 dB greater than that necessary to produce 50% modulation. Then input level was established at frequency of maximum response of the modulation circuit.

| Ref Level | Start Frequency | Stop Frequency | Center Frequency | RBW | VBW |
|-----------|-----------------|----------------|------------------|-------|---------|
| (dBm) | MHz | (MHz) | (MHz) | (kHz) | (kHz) |
| -8.70 | 464.163 | 464.263 | 464.21 | 0.30 | 1000.00 |

| M1/M2 Point | Level | Occupied Bandwidth | Authorized Bandwidth |
|-------------|-------|--------------------|----------------------|
| (MHz) | (dBm) | (kHz) | (kHz) |
| 464.20700 | -28.3 | 11.00 | 25.00 |
| 464.21800 | -27.3 | | |

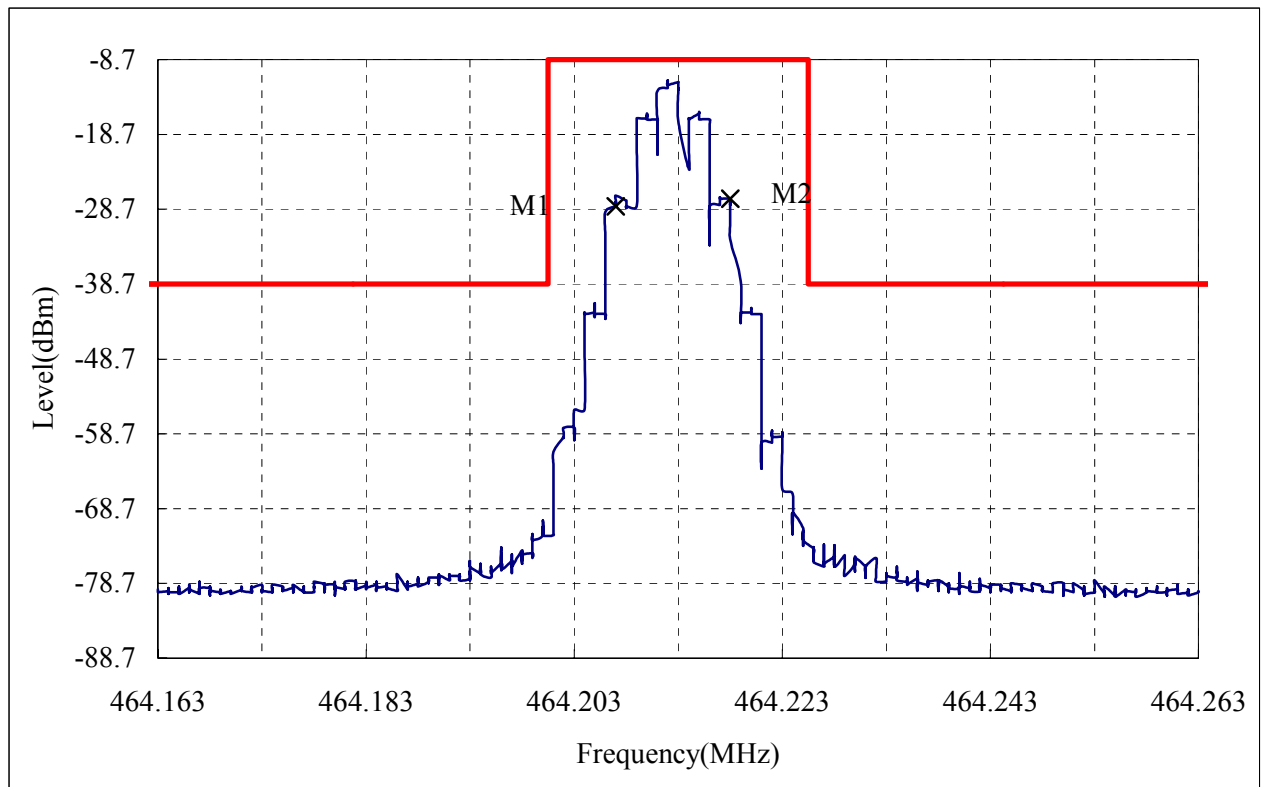

[NOTE]

1. Maximum response of audio frequency was 1.0kHz. and maximum frequency deviation was 4.15kHz. and audio input level was -52.0dBVrms.
2. Then 50% of maximum frequency deviation was 2.08kHz. and input level became to -67.0dBVrms.
3. Then EUT was modulated by 2.5kHz and audio input level became to -67.0 + 16 = -51.0dBVrms.

[Environment]

Temperature: 24°C

Humidity: 64%

[Summary of Test Results]

Above data shows that the test device complies with the requirements.

Tested Date : 15 April 2003

Tester Signature



Ikuya Minematsu

7. FIELD STRENGTH OF SPURIOUS RADIATION

7.1. Reference Rule and Specification

FCC Rule Part 90 [Section 90.217] and Part 2 Subpart J [Section 2.1053]

7.2. Test Procedure

- (1) Tune-up the transmitter(EUT).
- (2) Device Vertical : Place the device so that it's longest axis is vertical.
- (3) For each spurious measurement the receiving antenna is adjusted to the correct length for the frequency involved. These measurements are made from the lowest radio frequency generated in the EUT or 25MHz to the tenth harmonic of the carrier.
- (4) For each spurious frequency, raise and lower the receiving antenna to obtain a maximum reading on the spectrum analyzer with the antenna at horizontal polarity.
Then the turntable is rotated to further increase this maximum reading. Repeat this procedure of raising and lower the antenna and rotating the turntable until highest possible signal has been obtain. Record this maximum reading.
- (5) Repeat Step4 for each spurious frequency with the antennae polarized vertically.
- (6) Device Horizontal : Place the device so that it's longest axis is horizontal.
- (7) Repeat Step3, Step4, and Step5
- (8) The attenuation of the spurious in dB can be calculated from the following formula:

$$\begin{array}{rcccl} \text{Spurious Emission} & & \text{Carrier} & & \text{Spurious Emission} \\ \text{Attenuation} & = & \text{Power} & - & \text{Power} \\ \text{[dB]} & & \text{[dBm]} & & \text{[dBm]} \end{array}$$

7.3. Test Configuration

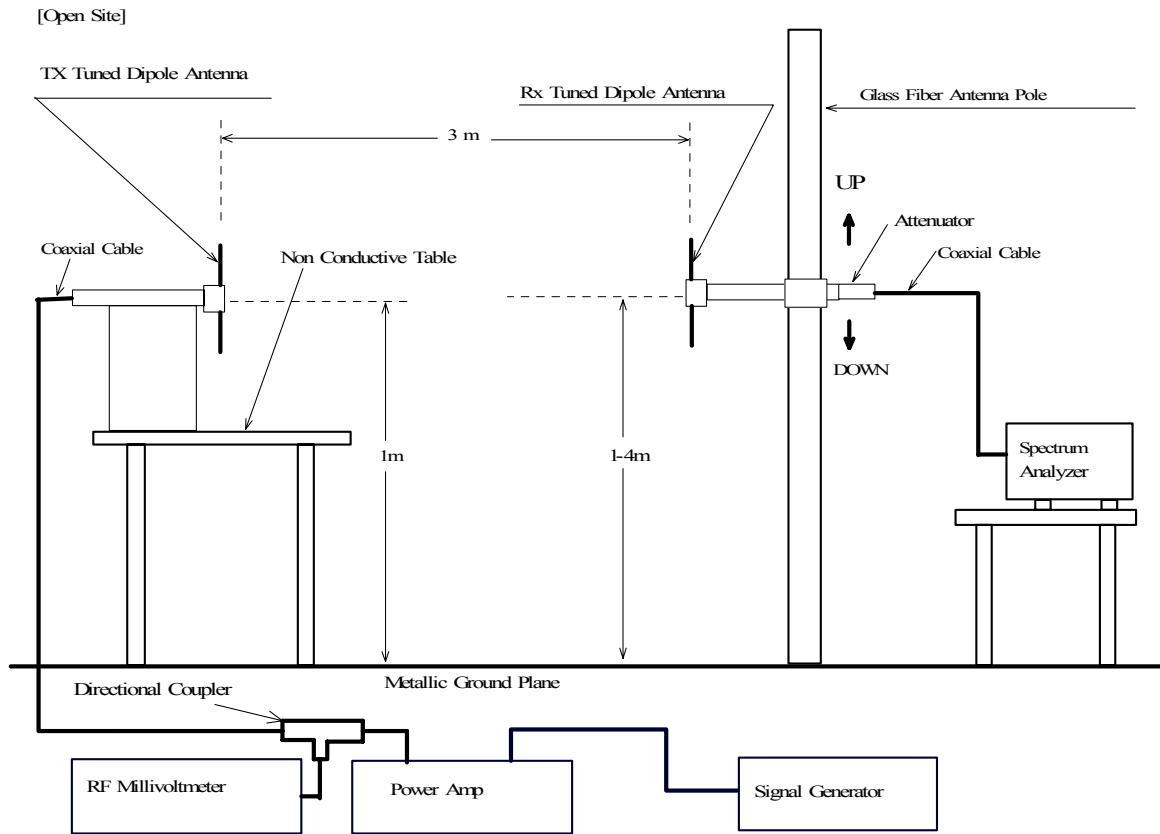

7.4. Photographs of EUT System Configuration

Horizontally Placing



Vertically Placing



7.5. Test Results

| Measured Frequency [MHz] | SG Output Level | | Tx Ant. Gain [dBi] | Cable Loss [dB] | Effective Radiated Power | | Deviation From Carrier [dBc] | Limit [dBc] |
|-------------------------------|------------------|------------------|-------------------------|----------------------|--------------------------|------------------|-----------------------------------|------------------|
| | Hori. [dBm] | Vert. [dBm] | | | Hori. [dBm] | Vert. [dBm] | | |
| 928.42 | -27.2 | -30.8 | 2.2 | 2.2 | -29.4 | -33.0 | 39.2 | 30.0 |
| 1392.63 | -43.5 | -45.0 | 11.7 | 2.7 | -36.7 | -38.2 | 46.5 | 30.0 |
| 1856.84 | -37.4 | -43.7 | 14.1 | 3.1 | -28.6 | -34.9 | 38.4 | 30.0 |
| 2321.05 | -47.1 | -49.5 | 16.3 | 3.5 | -36.5 | -38.9 | 46.3 | 30.0 |
| 2785.26 | -49.1 | -50.6 | 17.7 | 3.9 | -37.5 | -39.0 | 47.3 | 30.0 |
| 3249.47 | -52.7 | -54.5 | 18.9 | 4.2 | -40.2 | -42.0 | 50.0 | 30.0 |
| 3713.68 | -49.5 | -49.2 | 19.5 | 4.5 | -36.7 | -36.4 | 46.2 | 30.0 |
| 4177.89 | -51.8 | -50.5 | 20.0 | 4.8 | -38.8 | -37.5 | 47.3 | 30.0 |
| 4642.10 | -43.1 | -40.8 | 20.4 | 5.2 | -30.1 | -27.8 | 37.6 | 30.0 |

[Calculation method]

Effective Radiated Power (Horizontal or Vertical Polarization) [dBm]
= Meter Reading (Horizontal or Vertical Polarization) [dBm] + Tx Ant. Gain [dBi] – 2.2 [dBi](*)
– Cable loss [dB]

* : Half wave dipole antenna isotropic gain

[Environment]

Temperature : 17°C Humidity : 40%

Tested Date : 9 April 2003

Tester Signature



Ikuya Minematsu

8. FREQUENCY STABILITY MEASUREMENT

8.1. Reference Rule and Specification

FCC Rule Part 90 [Section90.217(C)] and Part 2 Subpart J [Section2.1055]

8.2. Frequency vs Temperature Test

Test Setup Diagram

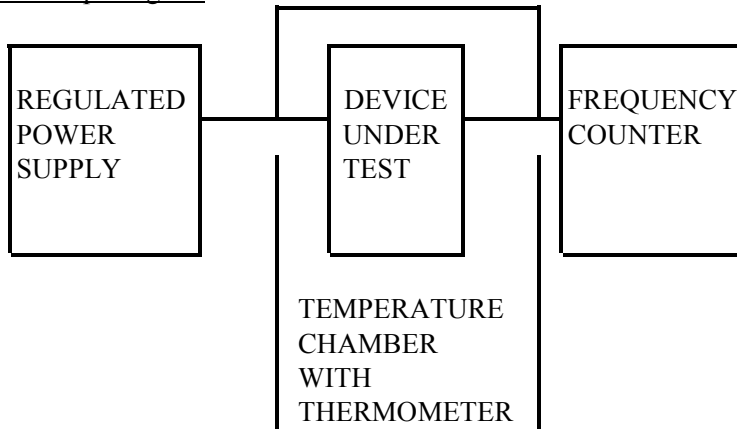

Test Result

Test Voltage: DC3.7V

| REFERENCE FREQUENCY [MHz] | TEMPERATURE [°C] | FREQUENCY DRIFT [kHz] | LIMIT [kHz] |
|-----------------------------------|-----------------------|-------------------------------|------------------|
| 464.2125 | -30 | -3.691 | ±12.5 |
| | -20 | -0.761 | |
| | -10 | 1.475 | |
| | 0 | 1.477 | |
| | +10 | 1.315 | |
| | +20 | 0.676 | |
| | +30 | -0.410 | |
| | +40 | -1.269 | |
| | +50 | -1.704 | |

8.3. Frequency vs Voltage Test

Test Setup Diagram : Same as (1)

Test Result

Temperature : +20°C

| REFERENCE FREQUENCY [MHz] | SUPPLIED VOLTAGE [Volt] | FREQUENCY DRIFT [kHz] | LIMIT [kHz] |
|--------------------------------------------|------------------------------------------|----------------------------------------|--------------------------|
| 464.2125 | 3.5 | 0.656 | ±12.5 |

[Environment] Temperature : 21 °C Humidity : 45 %

[Summary of Test Results]

Above data shows that the test device complies with the requirements.

Tested Date : 10 April 2003

Tester Signature



Hironobu Matsuyama

9. USED TEST EQUIPMENTS AND CALIBRATION STATUS

| Equipment | Manufacturer | Model No. | Specifications | KEC Control No. | Test Item (*) | Last Cal. | Next Cal. |
|--------------------------------------|-------------------------------|--------------|----------------------------------------------------------------|-----------------|---------------|-----------|-----------|
| Spectrum Analyzer | Advantest | R3261B | Frequency Range 9 kHz - 3.6 GHz | SA-33 | 3 | 2002/5 | 2003/5 |
| | Hewlett Packard | 71210C | Frequency Range 30 Hz - 25 GHz | SA-34 | 1,4 | 2002/10 | 2003/10 |
| Biconical Antenna | Schwarzbeck | BBA9106 | Frequency Range 30 MHz - 300 MHz | AN-94 | 4 | 2003/2 | 2004/2 |
| Log-Periodic | Schwarzbeck | UHALP9107 | Frequency Range 300 MHz - 1 GHz | AN-217 | 4 | 2003/2 | 2004/2 |
| Tuned Dipole Antenna | Kyoritsu | KBA-511S | Frequency Range 25 MHz - 500 MHz | AN-134 | 1,4 | 2002/4 | 2003/4 |
| | | | | AN-135 | 1,4 | 2003/2 | 2005/2 |
| | | KBA-611S | Frequency Range 500 MHz - 1 GHz | AN-137 | 1,4 | 2003/2 | 2005/2 |
| Power Meter | Hewlett Packard | E4419B | Frequency Range 50 MHz - 18 GHz | VV-39 | 4 | 2001/8 | 2003/8 |
| Power Sensor | Hewlett Packard | E4412A | Frequency Range 50 MHz - 18 GHz | VV-39-1 | 4 | 2001/8 | 2003/8 |
| Coaxial Cable | Suhner | SUCOFLEX 104 | Length : 10m [SMA(p)-SMA(p)] | CL-45 | 1,4 | 2003/2 | 2004/2 |
| | | | | CL-46 | 1,4 | 2003/2 | 2004/2 |
| Attenuator | Weinschel Engineering | 2 | Frequency Range 1 MHz – 20 GHz -10 dB | AT-42-1 | 6 | 2003/2 | 2004/2 |
| Regurated DC Power Supply | Kikusui | PAB18-3A | Output 0-18V, 3A | PD-32 | 2,3,6 | – | – |
| Temperature Chamber With Thermometer | Tabai Mfg. | MC-710 | Temperature Range -75 - +100 °C | CH-31 | 3 | 2002/8 | 2003/8 |
| Frequency Counter | Anritsu | MF2412B | Freq.Range 10 Hz – 1 GHz | CU-18 | 3 | 2002/5 | 2003/5 |
| Multimeter | John Fluke | 37 | Volt Range 0.1mV - 1000 V Ampere Range 0.01 mA - 20 A | MM-91 | 2,3 | 2003/2 | 2004/3 |
| Digital Oscilloscope | Matsushita Communication Ind. | VP-5740A | Frequency Range DC -10 MHz | OS-22 | 2,3 | 2002/5 | 2003/5 |

- Continued -

| Equipment | Manufacturer | Model No. | Specifications | KEC Control No. | Test Item (*) | Last Cal. | Next Cal. |
|-----------------------------|--------------------------|-----------|---------------------------------------------------------------------|-----------------|---------------|-----------|-----------|
| Power Amp. | ENI | 60IL | Freq. Range: 800KHz to 1000MHz Gain:37dB (Max 1.2W) | AM-24 | 1 | 2002/6 | 2003/6 |
| Signal Generator | Willtron | 6759A-10 | Freq. Range: 50MHz to 40GHz | SG-38 | 1,4 | 2003/5 | 2004/5 |
| Synthesized Level Generator | Anritsu | MG443B | Freq. Range: 10Hz to 30MHz 600Ω Balance output | MG-41 | 2,3 | 2002/12 | 2003/12 |
| FM Linear Detector | Anritsu | MS61A | Freq. Range: 20 to 1000MHz Deviation: 0.05 to 300KHz | MM-54 | 2,3 | 2001/5 | 2002/5 |
| Variable Attenuator | Anritsu | MN510C | Freq. Range: DC to 500MHz Attenuation: 0 to 91dB (50 ohms) | SG-30-2 | 2,3 | 2003/1 | 2004/1 |
| AC Voltmeter | Matsushita Communication | VP-9631A | Freq. Range: 10Hz to 1MHz Level:300μV to 300V | VV-19 | 2,3 | 2002/8 | 2003/8 |
| | | VP-9690A | Freq. Range: 10Hz to 500KHz Level:300μV to 300V | VV-20 | 2,3 | 2002/8 | 2003/8 |

[Note]

- Test Item (*):
- 1: Measurement of RF Power Output (Substitution Method)
 - 2: Modulation Characteristics
 - 3: Emission Bandwidth
 - 4: Measurement of Field Strength of Spurious Radiation
 - 5: Measurement of Spurious Emission at Antenna Terminal
 - 6: Frequency Stability Measurement
 - N/A: Not Applicable

The overall program of calibration and verification of equipment is designed and operated so as to ensure that measurements made by KEC are traceable to national standards of measurement or equivalent abroad.