



EMI TEST REPORT

Test Report No. : 25AE0290-HO-1

Applicant : Matsushita Electric Industrial Co.,Ltd
Panasonic System Solutions Company

Type of Equipment : Center Module

Model No. : WX-CC2010

Test standard : FCC Part 90 : 2003

FCC ID : ACJ9TAWX-CC2010Z

Test Result : Complied

- 1.This test report shall not be reproduced in full or partial, without the written approval of UL Apex Co., Ltd.
- 2.The results in this report apply only to the sample tested.
- 3.This equipment is in compliance with above regulation. We hereby certify that the data contain a true representation of the EMC profile.
- 4.The test results in this report are traceable to the national or international standards.

Date of test:

September 15 to December 15, 2004

Tested by:



Kenichi Adachi
EMC Service

Tested by:



Hiroka Umeyama
EMC Service

Approved by:

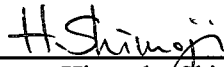

Hironobu Shimoji
Group Leader of
EMC Service

UL Apex Co., Ltd.

Head Office EMC Lab.

4383-326 Asama-cho, Ise-shi, Mie-ken 516-0021 JAPAN

Telephone : +81 596 24 8116

Facsimile : +81 596 24 8124

MF060b(10.04.03)

CONTENTS

	<u>PAGE</u>
SECTION 1: Client information	3
SECTION 2: Equipment under test (E.U.T.)	3
SECTION 3: Test specification, procedures and results	5
SECTION 4: Operation of E.U.T. during testing	7
SECTION 5: RF Output power	8
SECTION 6: Modulation Characteristics	8
SECTION 7: Emission Bandwidth	9
SECTION 8: Field Strength of Spurious Emission	9
SECTION 9: Frequency Stability	10
Test Setup	11
Worst Case Position (Z-axis:Horizontal / X-axis:Vertical)	12
APPENDIX 2: Test Instruments	13
APPENDIX 3: Data of EMI test	14
RF Output Power	14
Modulation Characteristics	15
Emission Bandwidth	17
Field Strength of Spurious Emission	18
Frequency Stability Measurement	19

UL Apex Co., Ltd.

Head Office EMC Lab.

4383-326 Asama-cho, Ise-shi, Mie-ken 516-0021 JAPAN

Telephone : +81 596 24 8116

Facsimile : +81 596 24 8124

MF060b(10.04.03)

SECTION 1: Client information

Company name : Matsushita Electric Industrial Co.,Ltd Panasonic System Solutions Company
Brand name : Panasonic
Address : 4-3-1,TSUNASHIMA-HIGASHI,YOKOHAMA-CITY,
KANAGAWA, 223-8639 JAPAN
Telephone Number : +81-045-540-5525
Facsimile Number : +81-045-540-5511
Contact Person : Shinichi ohgo

SECTION 2: Equipment under test (E.U.T.)

2.1 Identification of E.U.T.

Type of Equipment : Center Module
Model No. : WX-CC2010
Serial No. : DI0001
Rating : AC12V / 1.2A
Country of Manufacture : JAPAN
Receipt Date of Sample : September 10, 2004
Condition of EUT : Engineering prototype
(Not for Sale: This sample is equivalent to mass-produced items.)

UL Apex Co., Ltd.

Head Office EMC Lab.

4383-326 Asama-cho, Ise-shi, Mie-ken 516-0021 JAPAN

Telephone : +81 596 24 8116

Facsimile : +81 596 24 8124

MF060b(10.04.03)

2.2 Product Description

Model: WX-CC2010 (referred to as the EUT in this report) is the Center Module.

(Transmitter)

Equipment identification	:	Center Module
Intended use/Purpose of the equipment	:	Drive Through System for the first food store
Equipment Type	:	Transceiver
Frequency of Operation	:	from 468.6125MHz to 469.3875MHz
Other Clock Frequency	:	PLL clock 21.85MHz AF CPU clock 8.38MHz DSP clock 16.38MHz RF CPU clock 4.19MHz Baseband clock 3.58MHz
Modulation	:	Frequency modulation
Bandwidth / Channel spacing	:	12.5kHz / 25kHz
Transmit power or power range	:	25mW (not including the antenna gain)
Channel access protocol	:	Rotary SW
Mode of operation	:	Duplex
Antenna Gain	:	-3dBi
Antenna Type	:	Whip ¼ Lambda Antenna
Antenna connector Type	:	BNC
Method of Frequency Generation	:	Synthesizer
Power Supply	:	12VAC
Operating voltage (Inner)	:	12VDC,5VDC,3.3VDC,1.8VDC
Operating temperature range	:	-10 deg. C. to 50 deg. C.
Power & Signal Cable Length	:	>3m

(Receiver)

Type of Receiver	:	Double Super heterodyne
Frequency operation	:	PLL clock 21.85MHz Receive VCO 442.2125-442.9875MHz
Intermediate Frequency	:	21.4MHz, 450kHz
Other Clock Frequency	:	AF CPU clock 8.38MHz DSP clock 16.384MHz RF CPU clock 4.19MHz Baseband clock 3.58MHz
Antenna Type	:	Internal Antenna
Antenna Connector Type	:	SH Connector
Method of Frequency Generation	:	Synthesizer
Power Supply	:	12VAC
Operating voltage (Inner)	:	12VDC, 5VDC, 3.3VDC, 1.8VDC
Operating temperature	:	-10 deg. C. to 50 deg. C.

UL Apex Co., Ltd.

Head Office EMC Lab.

4383-326 Asama-cho, Ise-shi, Mie-ken 516-0021 JAPAN

Telephone : +81 596 24 8116

Facsimile : +81 596 24 8124

MF060b(10.04.03)

SECTION 3: Test specification, procedures and results

3.1 Test Specification

Test Specification : FCC Part90 : 2003
Title : PRIVATE LAND MOBILE RADIO SERVICES

3.2 Procedures and results

No.	Item	Test Procedure	Specification	Deviation	Worst margin	Results
1	RF Output Power	Section 2.1046 (a)(c)	Section 90.217	N/A	-	Complied
2	Modulation Characteristics	Section 2.1047 (a)(b)	-	N/A	-	Complied
3	Emission Bandwidth	Section 2.1049 (c)	-	N/A	-	Complied
4	Field Strength of Spurious Emission	Section 2.1053 (a)(b)	Section 90.217	N/A	1.8dB 938.43MHz Horizontal	Complied
5	Frequency Stability Measurement	Section 2.1055 (a)-(e)	Section 90.217(c)	N/A	-	Complied

Note: UL Apex's EMI Work Test Procedure QPM05.

3.3 Additions to Standards

No addition, deviation or exclusion has been made from standards.

3.4 Confirmation

UL Apex Co, Ltd. hereby confirms that E.U.T., in the configuration tested, complies with the specifications FCC Part 90 2003.

3.5 Uncertainty

Spurious Emission(Radiated)

The measurement uncertainty (with a 95% confidence level) for this test using Biconical antenna is ± 4.5 dB.

The measurement uncertainty (with a 95% confidence level) for this test using Logperiodic antenna is ± 5.2 dB.

The measurement uncertainty (with a 95% confidence level) for this test using Horn antenna is ± 6.6 dB.

The result is within Head Office EMC Lab's uncertainty.

UL Apex Co., Ltd.

Head Office EMC Lab.

4383-326 Asama-cho, Ise-shi, Mie-ken 516-0021 JAPAN

Telephone : +81 596 24 8116

Facsimile : +81 596 24 8124

MF060b(10.04.03)

3.6 Test Location

UL Apex Co., Ltd. Head Office EMC Lab. *NVLAP Lab. code: 200572-0
4383-326 Asama-cho, Ise-shi, Mie-ken 516-0021 JAPAN
Telephone : +81 596 24 8116
Facsimile : +81 596 24 8124

	Listed date (for NVLAP)	FCC Registration Number	IC Registration Number	Width x Depth x Height (m)	Size of reference ground plane (m) / horizontal conducting plane	Other rooms
No.1 semi-anechoic chamber	February 01, 2002	313583	IC4247	19.2 x 11.2 x 7.7m	7.0 x 6.0m	Preparation room
No.2 semi-anechoic chamber	June 05, 2002	846015	IC4247-2	7.5 x 5.8 x 5.2m	4.0 x 4.0m	-
No.3 shielded room	-	-	-	4.7 x 7.5 x 2.7m	4.7 x 7.5m	-
No.4 measurement room	-	-	-	3.1 x 5.0 x 2.7m	N/A	-

* Size of vertical conducting plane (for Conducted Emission test) : 2.0 x 2.0m for No.1 and No.2 semi-anechoic and No.3 measurement room.

3.7 Test setup and test instruments

Refer to APPENDIX 1 and 2.

UL Apex Co., Ltd.

Head Office EMC Lab.

4383-326 Asama-cho, Ise-shi, Mie-ken 516-0021 JAPAN
Telephone : +81 596 24 8116
Facsimile : +81 596 24 8124

MF060b(10.04.03)

SECTION 4: Operation of E.U.T. during testing

4.1 Operating Modes

The EUT was operated in a manner similar to typical use during the tests.

The mode is used : Continuous Transmitting mode

Justification : The system was configured in typical fashion (as a customer would normally use it) for testing.

4.2 Configuration and peripherals

Front View

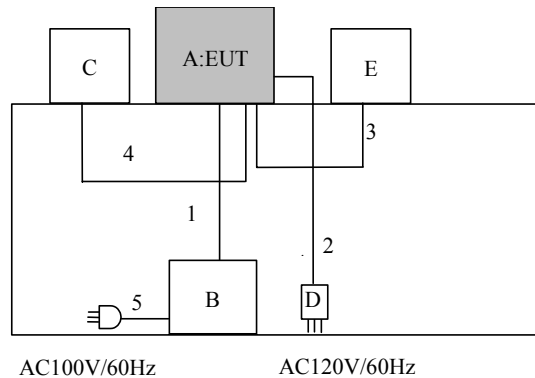

Cabling was taken into consideration and test data was taken under worst case conditions.

Description of EUT and Support equipment

No.	Item	Model number	Serial number	Manufacturer	FCC ID	Remark
A	Center Module	WX-CC2010	DI0001	Panasonic	ACJ9TAWX-CC2010Z	EUT
B	Pulse Generator *1	TG1304	164769	TTI	-	-
C	Speaker	WX-C550	-	Panasonic	-	-
D	AC Adaptor	WX-C516	AH0099	Panasonic	-	-
E	Microphone Speaker	WX-C550	-	Panasonic	-	-

*1: Pulse Generator was not used Frequency Stability Test.

List of cables used

No.	Name	Length (m)	Shield	Backshell Material
1	Audio Cable *1	1.5	N	Polyvinyl chloride
2	Power Cable	3.0	Y	Polyvinyl chloride
3	Mic. Speaker Cable	1.0	Y	Polyvinyl chloride
4	Speaker Cable	1.0	Y	Polyvinyl chloride
5	Power Cable	2.0	N	Polyvinyl chloride

*1: Audio Cable was not used Frequency Stability Test.

UL Apex Co., Ltd.

Head Office EMC Lab.

4383-326 Asama-cho, Ise-shi, Mie-ken 516-0021 JAPAN

Telephone : +81 596 24 8116

Facsimile : +81 596 24 8124

MF060b(10.04.03)

SECTION 5: RF Output power

Test Procedure : **FCC part 2.1046 (a)(c)**

- (1) Tune up the transmitter.
- (2) The receiving antenna is adjusted to the correct length for the carrier frequency.
- (3) Raise and lower the receiving antenna to obtain a maximum reading on the Spectrum Analyzer with the antenna at horizontal polarity. Then the turntable is rotated to further increase this maximum reading. Repeat this procedure of raising and lowering the antenna and rotating the turntable until the highest possible signal Obtains. Record this maximum reading.
- (4) Repeat step3 with the antenna polarized vertically.
- (5) Remove the transmitter and replace it with the half-wave dipole antenna. The center of this antenna is approximately at the same location as the center of the transmitter.
- (6) Feed the input of the half-wave dipole antenna with a signal generator connected to the antenna by means of a non-radiating cable. With the antennas at both transmitting and receiving antennas horizontally polarized and with the signal generator tuned to the carrier frequency, raise and lower the receiver antenna to obtain a maximum reading at the Spectrum Analyzer. Adjust the level of the signal generator output until the maximum reading at the Spectrum Analyzer is obtained.
- (7) Repeat step6 with both transmitting and receiving antennas vertically polarized.

Test data : **APPENDIX 3**

Test result : **Pass**

Test instruments : **APPENDIX 2**

SECTION 6: Modulation Characteristics

Test Procedure : **FCC part 2.1047 (a)(b)**

The Modulation Characteristics was measured with the device of modulation-analyzed function.

Test data : **APPENDIX 3**

Test result : **Pass**

Test instruments : **APPENDIX 2**

UL Apex Co., Ltd.

Head Office EMC Lab.

4383-326 Asama-cho, Ise-shi, Mie-ken 516-0021 JAPAN

Telephone : +81 596 24 8116

Facsimile : +81 596 24 8124

MF060b(10.04.03)

SECTION 7: Emission Bandwidth

Test Procedure : **FCC part 2.1049 (c)**

- (1) Set the reference level the spectrum analyzer to the unmodulated carrier level of the EUT.
- (2) The Carrier is modulated by a 2.5kHz tone at an input level 16dB greater than that necessary to produce 50 percent modulation. The input level shall be established at the frequency of maximum response of the audio modulation.

Test data : **APPENDIX 3**

Test result : **Pass**

Test instruments : **APPENDIX 2**

SECTION 8: Field Strength of Spurious Emission

Test Procedure

- (1) The Carrier is modulated by a 2.5kHz tone at an input level 16dB greater than that necessary to produce 50 percent modulation. The input level shall be established at the frequency of maximum response of the audio modulation.
- (2) Tune-up the transmitter (EUT).
- (3) EUT was placed on a platform of nominal size, 0.5m by 1.0m, raised 100cm above the conducting ground plane. The Radiated Electric Field Strength intensity has been measured in a Semi Anechoic Chamber with a ground plane and at a distance of 3m.
- (4) The height of the measuring varied between 1 and 4m and EUT was rotated a full revolution in order to obtain the maximum value of the electric field intensity. The measurements were performed for both vertical and horizontal antenna polarization with the Test Receiver or the Spectrum Analyzer.
- (5) The attenuation of the spurious in dB can be calculated from the following formula:

* **Spurious Emission Power = 10 * LOG({ (Electric Field Strength [V/m] * Distance:3[m]) ^ 2 } / 30)**

Spurious Emission Attenuation [dB]	=	Carrier Power [dBm]	-	Spurious Emission Power * [dBm]
---	---	----------------------------	---	--

The carrier level and noise levels were measured at each position in axes X, Y and Z of EUT, and the position that has the maximum noise levels were determined. With the position, the noise levels of all the frequencies was measured.

Test data : **APPENDIX 3**

Test result : **Pass**

Test instruments : **APPENDIX 2**

UL Apex Co., Ltd.

Head Office EMC Lab.

4383-326 Asama-cho, Ise-shi, Mie-ken 516-0021 JAPAN

Telephone : +81 596 24 8116

Facsimile : +81 596 24 8124

MF060b(10.04.03)

SECTION 9: Frequency Stability

Test Procedure : **FCC part 2.1055 (a)-(e)**

The Frequency Stability was measured with frequency counter.

Test data : **APPENDIX 3**

Test result : **Pass**

Test instruments : **APPENDIX 2**

UL Apex Co., Ltd.

Head Office EMC Lab.

4383-326 Asama-cho, Ise-shi, Mie-ken 516-0021 JAPAN

Telephone : +81 596 24 8116

Facsimile : +81 596 24 8124

MF060b(10.04.03)

APPENDIX 2: Test Instruments

Control No.	Instrument	Manufacturer	Model No	Test Item	Calibration Date * Interval(month)
MPM-04	Power Meter	Agilent	E4416A	1	2004/03/03 * 12
MPSE-04	Power sensor	Agilent	E9327A	1	2004/03/11 * 12
MSA-03	Spectrum Analyzer	Agilent	E4448A	1,3	2004/06/12 * 12
MRENT-09	Spectrum Analyzer	Advantest	R3273	1,2,4	2004/02/18 * 12
MPG-06	Pulse Generator	TTI	TG1304	1,2,3	2004/01/06 * 12
MCC-26	Microwave Cable	Suhner	SUCOFLEX104	1,2,3	2004/08/26 * 12
MST-01	Digitizing Oscilloscope	Sony Tektronix	TDS420A	1,2	2004/03/05 * 12
MAT-17	Attenuator	Weinschel Corp	93459	2	2004/01/29 * 12
MAT-10	Attenuator	Weinschel Corp	2	2	2003/12/16 * 12
MAEC-02	Anechoic Chamber	TDK	Semi Anechoic Chamber 3m	4	2004/04/12 * 12
MTR-02	Test Receiver	Rohde & Schwarz	ESCS30	4	2004/02/03 * 12
MCC-12	Coaxial Cable	Fujikura/Agilent	-	4	2004/02/24 * 12
MPA-06	Pre Amplifier	Hewlett Packard	8447D	4	2004/08/29 * 12
MAT-07	Attenuator(6dB)	Weinschel Corp	2	4	2003/12/16 * 12
MBA-02	Biconical Antenna	Schwarzbeck	BBA9106	4	2003/10/15 * 12
MLA-02 *1	Logperiodic Antenna	Schwarzbeck	USLP9143	4	2003/10/15 * 12
MLA-02 *2	Logperiodic Antenna	Schwarzbeck	USLP9143	4	2004/10/14 * 12
EST-09	Universal Counter	Agilent	53131A	5	2003/11/07 * 12
MDPS-01	DC Power Supply	Agilent	6642A	5	Pre Check
MHA-06	Horn Antenna	Schwarzbeck	BBHA9120D	4	2004/01/10 * 12
MCC-04	Microwave Cable	Storm	421-011	4	2004/01/06 * 12
MCC-24	Microwave Cable	Storm	-	4	2004/05/01 * 12
MPA-01	Pre Amplifier	Agilent	8449B	4	2004/02/06 * 12
MRENT-12	Modulation Analyzer	Anritsu	MS616B	2	2004/09/15* 12

*1: tested date : 2004/9/23,27

*2: tested date : 2004/12/15

All equipment is calibrated with traceable calibrations. Each calibration is traceable to the national or international standards.

Test Item:

- 1:RF Power Output
- 2:Modulation Characteristics
- 3:Bandwidth
- 4:Spurious emission(Radiated)
- 5:Frequency Stability

UL Apex Co., Ltd.

Head Office EMC Lab.

4383-326 Asama-cho, Ise-shi, Mie-ken 516-0021 JAPAN

Telephone : +81 596 24 8116

Facsimile : +81 596 24 8124

MF060b(10.04.03)

APPENDIX 3: Data of EMI test

RF Output Power

UL Apex Co., Ltd.
Head Office EMC Lab. Semi Anechoic Chamber No2

COMPANY	Matsushita Electric Industrial Co., Ltd.	REPORT NO	25AE0290-HO
EQUIPMENT	Center Module	REGULATION	FCC Part90.217 / Part2.1046
MODEL	WX-CC2010	TEST DISTANCE	3m
S/N	DI0001	DATE	15/12/2004
POWER	AC12V (AC adapter:AC120V/ 60Hz)	TEMPERATURE	22deg.C.
MODE	Tx 469.2125 MHz	HUMIDITY	30%
POSITION	H: Z-axis / V: X-axis	CALIBRATION	OK
		ENGINEER	Hiroka Umeyama

No.	FREQ [MHz]	SG READING [dBm]		CABLE LOSS [dB]	ATTEN [dB]	RESULT [dBm]		RESULT [mW]		LIMITS (ERP) [mW]
		HOR	VER			HOR	VER	HOR	VER	
1	468.94	24.7	25.2	1.5	9.9	13.3	13.8	21.4	24.0	120.0

CALCULATION:READING(SG)-LOSS(CABLE)-ATTEN
Tx/Rx ANTENNA:Dipole Antenna

UL Apex Co., Ltd.

Head Office EMC Lab.

4383-326 Asama-cho, Ise-shi, Mie-ken 516-0021 JAPAN

Telephone : +81 596 24 8116

Facsimile : +81 596 24 8124

MF060b(10.04.03)

Modulation Characteristics
Transmitter Pre Emphasis Frequency and Deviation

UL Apex Co., Ltd.
Head Office EMC Lab. No.3 measurement room

COMPANY : Matsushita Electric Industrial Co., Ltd.
EQUIPMENT : Center Module
MODEL : WX-CC2010
S/N : DI0001
POWER : AC 12V (AC adapter : AC 120V/ 60Hz)
MODE : Tx : 469.2125MHz

REPORT NO : 25AE0290-HO
REGULATION : FCC part 2.1047
TEST DISTANCE : -
DATE : 09/15/200- 09/16/2004
TEMPERATURE : 24.3deg.C 23.2deg.C
HUMIDITY : 54% 53%
ENGINEER : Kenichi Adachi

Input Freq	Deviation [kHz]		
	-2.87dBm	-17.5dBm	-30dBm
100	1.10	1.05	1.00
200	1.70	1.30	1.20
300	2.40	1.98	1.40
400	2.40	1.97	1.42
500	2.45	1.98	1.45
600	2.45	1.98	1.45
700	2.48	2.00	1.45
800	2.49	2.01	1.45
900	2.50	2.01	1.46
1000	2.50	2.02	1.46
(1100)	2.52	2.03	1.47
1200	2.54	2.04	1.47
(1300)	2.55	2.05	1.47
(1400)	2.55	2.05	1.48
1500	2.56	2.06	1.48
(1600)	2.58	2.07	1.49
1700	2.59	2.08	1.49
(1800)	2.60	2.09	1.50
(1900)	2.61	2.09	1.50
2000	2.62	2.10	1.51
(2100)	2.63	2.10	1.51
2200	2.63	2.10	1.51
(2300)	2.64	2.10	1.51
(2400)	2.64	2.10	1.51
2500	2.65	2.10	1.51
(2600)	2.62	2.09	1.50
2700	2.59	2.08	1.49
(2800)	2.54	2.05	1.47
(2900)	2.50	2.01	1.46
3000	2.45	1.98	1.44
(3100)	2.36	1.92	1.41
(3200)	2.27	1.86	1.38
(3300)	2.17	1.80	1.36
(3400)	2.08	1.74	1.33
3500	1.99	1.68	1.30
(3600)	1.91	1.62	1.27
(3700)	1.83	1.57	1.25
(3800)	1.75	1.51	1.22
(3900)	1.67	1.46	1.20
4000	1.59	1.40	1.17
(4100)	1.53	1.36	1.15
(4200)	1.48	1.33	1.13
(4300)	1.42	1.29	1.12
(4400)	1.37	1.26	1.10
4500	1.31	1.22	1.08
(4600)	1.28	1.20	1.07
(4700)	1.25	1.18	1.06
(4800)	1.21	1.15	1.06
(4900)	1.18	1.13	1.05
5000	1.15	1.11	1.04

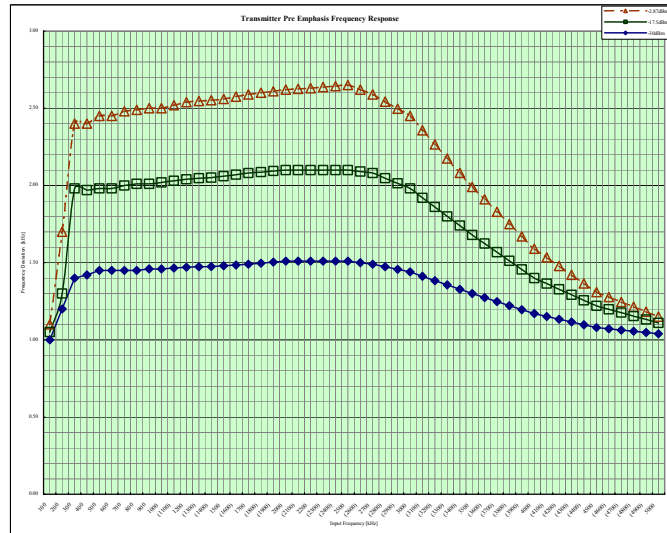

* Input level : -2.87dBm , -17.5dBm , -30dBm
* MS616B setting : HPF: 50Hz / LPF: 20kHz
* note : Frequency's () is calculate data.

Modulation Characteristics

Transmitter Deviation for Range of Input Signal Level and Modulating Frequencies

Head Office EMC Lab. No.3 measurement room

COMPANY : Matsushita Electric Industrial Co., Ltd.	REPORT NO : 25AE0290-HO
EQUIPMENT : Center Module	REGULATION : FCC part 2.1047
MODEL : WX-CC2010	TEST DISTANCE : -
S/ N : DI0001	DATE : 09/15/2004
POWER : AC 12V (AC adapter : AC 120V/ 60Hz)	TEMPERATURE : 24.3deg.C
MODE : Tx : 469.2125MHz	HUMIDITY : 54%
	ENGINEER : Kenichi Adachi

Input [dBm]	Deviation [kHz](PK)	
	400Hz	4KHz
-80.0	0.15	0.15
-75.0	0.15	0.16
-70.0	0.16	0.16
-65.0	0.17	0.17
-60.0	0.20	0.19
-55.0	0.21	0.24
-50.0	0.26	0.30
-45.0	0.32	0.34
-40.0	0.38	0.40
-35.0	0.46	0.49
-30.0	0.56	0.61
-25.0	0.73	0.77
-20.0	0.93	1.01
-15.0	1.22	1.32
-10.0	1.58	1.71
-5.0	2.07	2.24
0.0	2.61	2.62
5.0	2.60	2.68
10.0	2.63	2.70

* Input Frequency : 400Hz, 2.9kHz, 4kHz
* MS616B setting : HPF: 50Hz, LPF: 20kHz

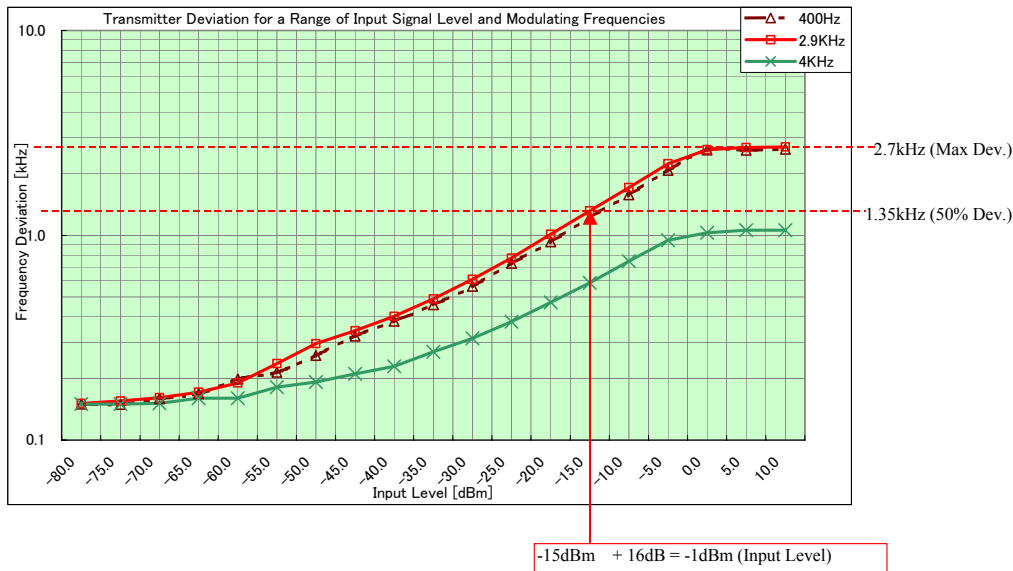

Emission Bandwidth

UL Apex Co., Ltd.
 Head Office EMC Lab. No3 Measurements room.

COMPANY Matsushita Electric Industrial Co.,Ltd.
 EQUIPMENT Center Module
 MODEL WX-CC2010
 S/N DI0001
 POWER AC12V (AC adapter AC 120V / 60Hz)
 MODE Transmitting

REPORT NO. 25AE0290-HO
 REGULATION Fcc Part2.1049
 TEST DISTANCE -
 DATE 09/17/2004
 TEMPERATURE 23deg.C
 HUMIDITY 57%
 ENGINEER Kenichi Adachi

(1) No input (No modulation)

99% Occupied Bandwidth 2.42 kHz

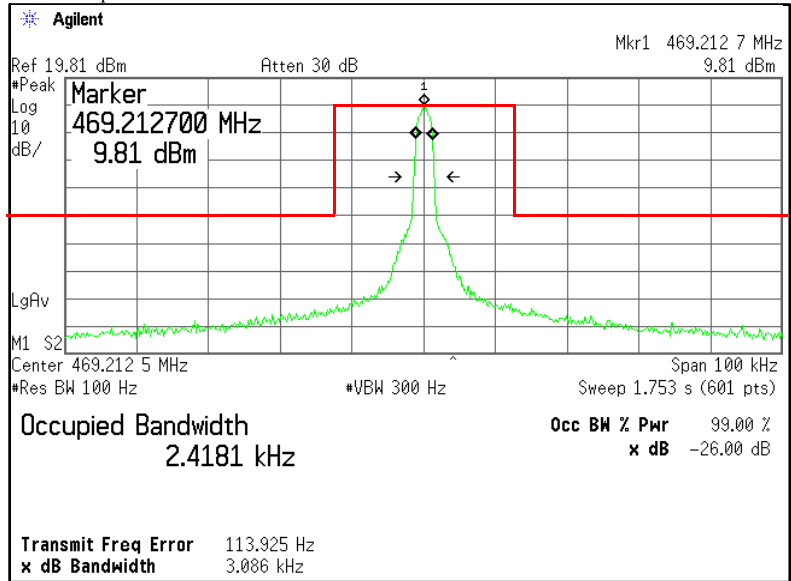

(2) Input Level : -1dBm (= 50% deviation Level + 16dBm), Input Frequency : 2.5kHz

99% Occupied Bandwidth : 10.81 kHz

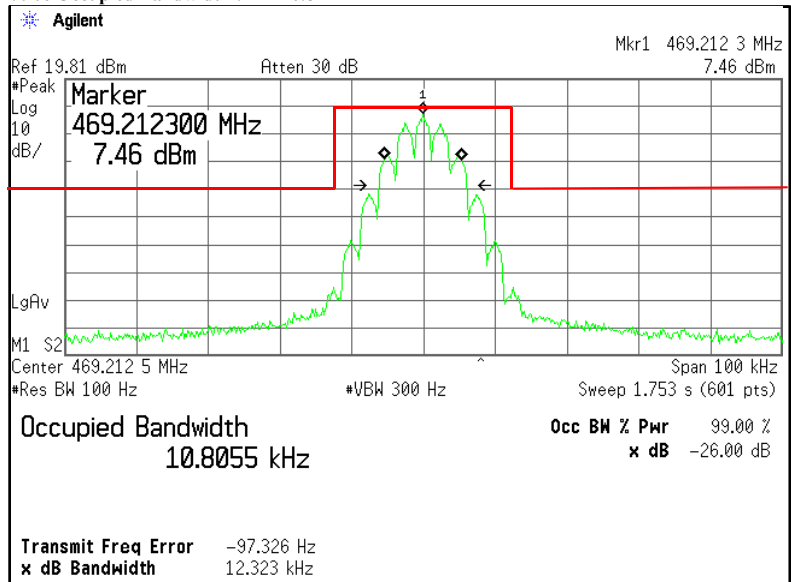

UL Apex Co., Ltd.

Head Office EMC Lab.

4383-326 Asama-cho, Ise-shi, Mie-ken 516-0021 JAPAN

Telephone : +81 596 24 8116

Facsimile : +81 596 24 8124

Field Strength of Spurious Emission

UL Apex Co., Ltd.
Head Office EMC Lab. Semi Anechoic Chamber : No.2

COMPANY	Matsushita Electric Industrial Co.,Ltd.	REPORT NO	25AE0290-HO
EQUIPMENT	Center Module	REGULATION	FCC part 90.217
MODEL	WX-CC2010	TEST METHOD	FCC Part2 Section 2.1053
S/N	DI0001	TEST DISTANCE	3 m
POWER	AC120V / 60Hz (EUT : AC12V)	DATE	09/23/2004 09/27/2004
MODE	Tx 469.2125 MHz	TEMPERATURE	26deg.C. 23deg.C.
POSITION	H: Z-axis / V: X-axis	HUMIDITY	60% 56%
Height	1m	ENGINEER	Kenichi Adachi

No.	FREQUENCY [MHz]	Electric Field Strength (After Factor Calculation) [dBuV/m]		RESULT [dBm] (dBm)		LIMIT [dBm] (ERP)	MARGIN [dB]		Mode
		HOR	VER	HOR	VER		HOR	VER	
1	440.00	37.1	42.9	-58.1	-52.3	-10.8	47.3	41.5	Operating
2	442.82	38.0	35.4	-57.2	-59.8	-10.8	46.4	49.0	Operating
3	469.22	114.4	113.8	19.2	18.6	19.2	-	-	Operating (carrier)
4	938.43	82.6	81.0	-12.6	-14.2	-10.8	1.8	3.4	Operating
5	1407.60	64.6	63.9	-30.6	-31.3	-10.8	19.8	20.5	Operating
6	1876.84	68.9	72.3	-26.3	-22.9	-10.8	15.5	12.1	Operating
7	2346.10	63.7	64.1	-31.5	-31.1	-10.8	20.7	20.3	Operating
8	2560.29	59.4	63.3	-35.8	-31.9	-10.8	25.0	21.1	Operating
9	2815.24	66.2	65.4	-29.0	-29.8	-10.8	18.2	19.0	Operating
10	3284.50	66.6	66.0	-28.6	-29.2	-10.8	17.8	18.4	Operating
11	3753.76	56.3	58.2	-38.9	-37.0	-10.8	28.1	26.2	Operating
12	4222.86	61.1	62.3	-34.1	-32.9	-10.8	23.3	22.1	Operating
13	4692.13	59.3	59.3	-35.9	-35.9	-10.8	25.1	25.1	Operating

Rx-ANTENNA : Biconical Antena(30-300MHz), Logperriodic Antenna(300-1000MHz), Horn Antenna(1-19GHz)
Tx-ANTENNA : Dipole Antenna(30-1000MHz), Horn Antenna(1-19GHz)
All other emissions were at least 20dB below the specification limit.
*The noise level was too low to detect.
The noise was measured at each position of all three axes X, Y and Z to compare the level, and the maximum noise.
With the result above, the effective radiated power was calculated on the basis of the reference value
- for the calibration data on the substitution measurement.

Below 1GHz : S/A PK(RBW/VBW:10kHz) ,
Above 1GHz : S/A PK(RBW/VBW:1MHz)

FCC 2.1053 Transmitters limits for spurious emissions

Range		Limit(dBm)		No
Start	End	Operating	Standby	
25	468.2025	-10.8	-10.8	1
468.2125	470.2025	19.2	19.2	2
470.2125	12750	-10.8	-10.8	3

Frequency Stability Measurement

UL Apex Co., Ltd.
Head Office EMC Lab. No.3 Measurement Room

COMPANY : Matsushita Electric Industrial Co.,Ltd.	REPORT NO : 25AE0290-HO
EQUIPMENT : Center Module	REGULATION : Fcc Part90 Section90.217
MODEL : WX-CC2010	TEST METHOD : Fcc Part 2 Section 2.1055(a)(1)and(b),(d)(1)
S/N : D10001	TEST DISTANCE : -
POWER : AC 120V / 60Hz (EUT: AC12V)	DATE : 09/20/2004
MODE : Tx : 469.2125 MHz	TEMPERATURE : 23 deg.C
	HUMIDITY : 49 %
	ENGINEER : Kenichi Adachi

Temp. [deg.C]	Volt. [V]		Frequency Reading [MHz]	Frequency Error [kHz]	Limit (12.5kHz) [kHz]	Margin [kHz]
-30.0	120.0	On	469.2123475	-1.43	12.50	11.07
		2 min.	469.2127667	-1.02	12.50	11.48
		5min.	469.2129804	-0.80	12.50	11.70
		10 min.	469.2129545	-0.83	12.50	11.67
-20.0	120.0	On	469.2147945	1.01	12.50	11.49
		2 min.	469.2150396	1.26	12.50	11.24
		5min.	469.2150864	1.30	12.50	11.20
		10 min.	469.2150381	1.26	12.50	11.24
-10.0	120.0	On	469.2158145	2.03	12.50	10.47
		2 min.	469.2158195	2.04	12.50	10.46
		5min.	469.2158162	2.03	12.50	10.47
		10 min.	469.2158110	2.03	12.50	10.47
0.0	120.0	On	469.2150287	1.25	12.50	11.25
		2 min.	469.2150938	1.31	12.50	11.19
		5min.	469.2152698	1.49	12.50	11.01
		10 min.	469.2154585	1.68	12.50	10.82
10.0	120.0	On	469.2151732	1.39	12.50	11.11
		2 min.	469.2151174	1.33	12.50	11.17
		5min.	469.2150298	1.25	12.50	11.25
		10 min.	469.2149943	1.21	12.50	11.29
20.0	120.0	On	469.2141770	0.39	12.50	12.11
		2 min.	469.2140312	0.25	12.50	12.25
		5min.	469.2139132	0.13	12.50	12.37
		10 min.	469.2137832	0.00	12.50	12.50
30.0	120.0	On	469.2137213	-0.06	12.50	12.44
		2 min.	469.2135761	-0.21	12.50	12.29
		5min.	469.2128852	-0.90	12.50	11.60
		10 min.	469.2125525	-1.23	12.50	11.27
40.0	120.0	On	469.2126098	-1.17	12.50	11.33
		2 min.	469.2124083	-1.37	12.50	11.13
		5min.	469.2121940	-1.59	12.50	10.91
		10 min.	469.2117934	-1.99	12.50	10.51
50.0	120.0	On	469.2119698	-1.81	12.50	10.69
		2 min.	469.2117600	-2.02	12.50	10.48
		5min.	469.2115723	-2.21	12.50	10.29
		10 min.	469.2111481	-2.63	12.50	9.87

Temp. [deg.C]	Volt. [V]		Frequency Reading [MHz]	Frequency Error [kHz]	Limit (12.5kHz) [kHz]	Margin [kHz]
20.0	138.0	On	469.2150650	1.28	12.50	11.22
		2 min.	469.2150155	1.23	12.50	11.27
		5min.	469.2149433	1.16	12.50	11.34
		10 min.	469.2148735	1.09	12.50	11.41
20.0	102.0	On	469.2141463	0.36	12.50	12.14
		2 min.	469.2141046	0.32	12.50	12.18
		5min.	469.2139360	0.15	12.50	12.35
		10 min.	469.2138193	0.04	12.50	12.46