



# RADIO TEST REPORT

**Test Report No. : 11500829H-A-R1**

**Applicant** : **Panasonic Corporation of North America**  
**Type of Equipment** : **Common Trigger Box**  
**Model No.** : **WV-TW37003**  
**FCC ID** : **ACJ9TAWV-TW37003**  
**Test regulation** : **FCC Part 15 Subpart C: 2016**  
**(\*WLAN, Bluetooth Low Energy part)**  
**Test Result** : **Complied**

1. This test report shall not be reproduced in full or partial, without the written approval of UL Japan, Inc.
2. The results in this report apply only to the sample tested.
3. This sample tested is in compliance with the above regulation.
4. The test results in this report are traceable to the national or international standards.
5. This test report must not be used by the customer to claim product certification, approval, or endorsement by NVLAP, NIST, or any agency of the Federal Government.
6. This test report covers Radio technical requirements. It does not cover administrative issues such as Manual or non-Radio test related Requirements. (if applicable)
7. This report is a revised version of 11500829H-A. 11500829H-A is replaced with this report.

**Date of test:** December 13 to 22, 2016

**Representative test engineer:**

  
Tomoki Matsui  
Engineer

Consumer Technology Division

**Approved by:**

  
Tsubasa Takayama

Engineer

Consumer Technology Division



NVLAP LAB CODE: 200572-0

This laboratory is accredited by the NVLAP LAB CODE 200572-0, U.S.A. The tests reported herein have been performed in accordance with its terms of accreditation.

\*As for the range of Accreditation in NVLAP, you may refer to the WEB address,  
[http://japan.ul.com/resources/emc\\_accredited/](http://japan.ul.com/resources/emc_accredited/)

**UL Japan, Inc.**

**Ise EMC Lab.**

4383-326 Asama-cho, Ise-shi, Mie-ken 516-0021 JAPAN

Telephone : +81 596 24 8999

Facsimile : +81 596 24 8124

13-EM-F0429



---

<b>CONTENTS</b>	<b>PAGE</b>
<b>SECTION 1: Customer information.....</b>	<b>4</b>
<b>SECTION 2: Equipment under test (E.U.T.).....</b>	<b>4</b>
<b>SECTION 3: Test specification, procedures &amp; results.....</b>	<b>6</b>
<b>SECTION 4: Operation of E.U.T. during testing.....</b>	<b>9</b>
<b>SECTION 5: Radiated Spurious Emission .....</b>	<b>12</b>
<b>SECTION 6: Antenna Terminal Conducted Tests.....</b>	<b>14</b>
<b>APPENDIX 1: Test data .....</b>	<b>15</b>
6dB Bandwidth .....	15
Maximum Peak Output Power .....	18
Average Output Power .....	22
Radiated Spurious Emission .....	25
Conducted Spurious Emission .....	46
Power Density .....	50
99%Occupied Bandwidth .....	53
<b>APPENDIX 2: Test instruments .....</b>	<b>55</b>
<b>APPENDIX 3: Photographs of test setup .....</b>	<b>56</b>
Radiated Spurious Emission .....	56
Worst Case Position .....	57

## **SECTION 1: Customer information**

### **Applicant**

Company Name : Panasonic Corporation of North America  
Address : Two Riverfront Plaza, Newark, NJ 07102-5490  
Telephone Number : +1-201-348-7724  
Facsimile Number : +1-201-392-4564  
Contact Person : Vir Angelo Lontoc

### **Manufacturer**

Company Name : Panasonic System Networks Co., Ltd.  
Address : 4-1-62, Minoshima, Hakata-ku, Fukuoka 812-8531, Japan  
Telephone Number : +81-50-3380-1993  
Facsimile Number : +81-50-3380-2002  
Contact Person : Yukio Kaneko

#### **\*Remarks:**

Panasonic Corporation of North America designates Panasonic System Networks Co., Ltd. as manufacturer of the product (Common Trigger Box).

## **SECTION 2: Equipment under test (E.U.T.)**

### **2.1 Identification of E.U.T.**

Type of Equipment : Common Trigger Box  
Model No. : WV-TW37003  
Serial No. : Refer to Section 4, Clause 4.2  
Rating : DC 12 V, DC 24 V  
Receipt Date of Sample : December 10, 2016  
Country of Mass-production : Japan  
Condition of EUT : Engineering prototype  
(Not for Sale: This sample is equivalent to mass-produced items.)  
Modification of EUT : No Modification by the test lab

---

**UL Japan, Inc.**

**Ise EMC Lab.**

4383-326 Asama-cho, Ise-shi, Mie-ken 516-0021 JAPAN

Telephone : +81 596 24 8999

Facsimile : +81 596 24 8124

## 2.2 Product Description

Model: WV-TW37003 (referred to as the EUT in this report) is a Common Trigger Box.

### Radio Specification

Radio Type : Transceiver  
Power Supply (inner) : DC 4.0 V (POWER), DC 1.8 V (IO)  
Clock frequency (crystal) : 37.4 MHz

	IEEE802.11b	IEEE802.11g/n (20 M band)	IEEE802.11a/n/ac (20 M band)	IEEE802.11n/ac (40 M band)	IEEE802.11ac (80 M band)
Frequency of operation	2412 MHz to 2462 MHz <sup>*1)</sup>	2412 MHz to 2462 MHz <sup>*1)</sup>	5745 MHz to 5825 MHz	5755 MHz 5795 MHz	5775 MHz
Type of modulation	DSSS (CCK, DQPSK, DBPSK)	OFDM-CCK (64QAM, 16QAM, QPSK, BPSK)	OFDM (64QAM, 16QAM, QPSK, BPSK, 256QAM(IEEE802.11ac only))		
Channel spacing	5MHz		20MHz	40MHz	80MHz
Antenna type	Patterned dipole antenna				
Antenna Connector type	RP-SMA Jack (Female)				
Antenna Gain	-0.8 dBi (2.4 GHz Band), -8.1 dBi (5 GHz Band) *including cable loss				

	Bluetooth Ver.4.1 with EDR function / Bluetooth Low Energy <sup>*1)</sup>
Frequency of operation	2402 MHz - 2480 MHz
Type of modulation	BT: FHSS (GFSK, $\pi/4$ -DQPSK, 8-DPSK) LE: GFSK
Channel spacing	BT: 1 MHz LE: 2 MHz
Antenna type	Patterned dipole antenna
Antenna Connector type	RP-SMA Jack (Female)
Antenna Gain	-0.8 dBi *including cable loss

\*1) This test report applies to WLAN (2.4 GHz Band only) and Bluetooth Low Energy.

\*Wireless LAN and Bluetooth do not transmit simultaneously.

### **SECTION 3: Test specification, procedures & results**

#### **3.1 Test Specification**

Test Specification : FCC Part 15 Subpart C  
FCC Part 15 final revised on November 14, 2016 and effective December 14, 2016

Title : FCC 47CFR Part15 Radio Frequency Device Subpart C Intentional Radiators  
Section 15.207 Conducted limits  
Section 15.247 Operation within the bands 902-928MHz,  
2400-2483.5MHz, and 5725-5850MHz

\* The revision on November 14, 2016, does not affect the test specification applied to the EUT.

#### **3.2 Procedures and results**

Item	Test Procedure	Specification	Worst margin	Results	Remarks
Conducted Emission	FCC: ANSI C63.10-2013 6. Standard test methods IC: RSS-Gen 8.8	FCC: Section 15.207 IC: RSS-Gen 8.8		N/A *1)	-
6dB Bandwidth	FCC: KDB 558074 D01 DTS Meas Guidance v03r05 IC: -	FCC: Section 15.247(a)(2) IC: RSS-247 5.2(1)	See data.	Complied	Conducted
Maximum Peak Output Power	FCC: KDB 558074 D01 DTS Meas Guidance v03r05 IC: RSS-Gen 6.12	FCC: Section 15.247(b)(3) IC: RSS-247 5.4(4)		Complied	Conducted
Power Density	FCC: KDB 558074 D01 DTS Meas Guidance v03r05 IC: -	FCC: Section 15.247(e) IC: RSS-247 5.2(2)		Complied	Conducted
Spurious Emission Restricted Band Edges	FCC: KDB 558074 D01 DTS Meas Guidance v03r05 IC: RSS-Gen 6.13	FCC: Section 15.247(d) IC: RSS-247 5.5 RSS-Gen 8.9 RSS-Gen 8.10	1.7 dB 1150.000 MHz, Horizontal / Vertical, AV	Complied	Conducted (below 30 MHz)/ Radiated (above 30 MHz) *2)

Note: UL Japan, Inc.'s EMI Work Procedures No. 13-EM-W0420 and 13-EM-W0422.

\*1) The test is not applicable since the EUT is not the device that is designed to be connected to the public utility (AC) power line.

\*2) Radiated test was selected over 30 MHz based on section 15.247(d) and KDB 558074 D01 DTS Meas Guidance v03r05 12.2.7.

\* In case any questions arise about test procedure, ANSI C63.10: 2013 is also referred.

#### **FCC Part 15.31 (e)**

The EUT provides stable voltage (DC 4.0 V, DC 1.8 V) constantly to the wireless transmitter regardless of input voltage. The test was performed with DC 12.0 V by using DC power supply.  
That does not affect the test result, therefore the EUT complies with the requirement.

#### **FCC Part 15.203 Antenna requirement**

The EUT has a unique coupling/antenna connector (RP-SMA Jack). Therefore the equipment complies with the requirement of 15.203.

**UL Japan, Inc.**

**Ise EMC Lab.**

4383-326 Asama-cho, Ise-shi, Mie-ken 516-0021 JAPAN

Telephone : +81 596 24 8999

Facsimile : +81 596 24 8124

### 3.3 Addition to standard

Item	Test Procedure	Specification	Worst margin	Results	Remarks
99% Occupied Bandwidth	IC: RSS-Gen 6.6	IC: -	N/A	-	Conducted

Other than above, no addition, exclusion nor deviation has been made from the standard.

### 3.4 Uncertainty

#### EMI

The following uncertainties have been calculated to provide a confidence level of 95 % using a coverage factor  $k = 2$ .  
Ise EMC Lab.

Antenna terminal test Uncertainty (+/-)							
Power meter		Conducted emission and Power density			Conducted emission		Channel power
Below 1 GHz	Above 1 GHz	Below 1 GHz	1 GHz - 3 GHz	3 GHz - 18 GHz	18 GHz - 26.5 GHz	26.5 GHz - 40 GHz	
0.9 dB	1.0 dB	1.4 dB	1.5 dB	2.8 dB	2.8 dB	2.9 dB	2.6 dB

Test distance	Radiated emission (+/-) 9 kHz - 30 MHz
3m	3.8 dB
10m	3.7 dB

Polarity	Radiated emission (Below 1GHz)			
	(3 m*) (+/-)		(10 m*) (+/-)	
	30 - 200 MHz	200 - 1000MHz	30 - 200 MHz	200 - 1000MHz
Horizontal	5.0 dB	5.3 dB	5.0 dB	5.0 dB
Vertical	4.7 dB	5.9 dB	5.0 dB	5.1 dB

Radiated emission (Above 1GHz)				
(3 m*) (+/-)		(1 m*) (+/-)		(10 m*) (+/-)
1 - 6GHz	6 - 18GHz	10 - 26.5 GHz	26.5 - 40GHz	1 - 18 GHz
5.2 dB	5.4 dB	5.5 dB	5.5 dB	5.4 dB

\*Measurement distance

#### Radiated emission test

The data listed in this report meets the limits unless the uncertainty is taken into consideration.

### 3.5 Test Location

UL Japan, Inc. Ise EMC Lab. \*NVLAP Lab. code: 200572-0  
4383-326 Asama-cho, Ise-shi, Mie-ken 516-0021 JAPAN  
Telephone: +81 596 24 8999, Facsimile: +81 596 24 8124

Test site	IC Registration Number	Width x Depth x Height (m)	Size of reference ground plane (m) / horizontal conducting plane	Other rooms	Maximum measurement distance
No.1 semi-anechoic chamber	2973C-1	19.2 x 11.2 x 7.7	7.0 x 6.0	No.1 Power source room	10 m
No.2 semi-anechoic chamber	2973C-2	7.5 x 5.8 x 5.2	4.0 x 4.0	-	3 m
No.3 semi-anechoic chamber	2973C-3	12.0 x 8.5 x 5.9	6.8 x 5.75	No.3 Preparation room	3 m
No.3 shielded room	-	4.0 x 6.0 x 2.7	N/A	-	-
No.4 semi-anechoic chamber	2973C-4	12.0 x 8.5 x 5.9	6.8 x 5.75	No.4 Preparation room	3 m
No.4 shielded room	-	4.0 x 6.0 x 2.7	N/A	-	-
No.5 semi-anechoic chamber	-	6.0 x 6.0 x 3.9	6.0 x 6.0	-	-
No.6 shielded room	-	4.0 x 4.5 x 2.7	4.0 x 4.5	-	-
No.6 measurement room	-	4.75 x 5.4 x 3.0	4.75 x 4.15	-	-
No.7 shielded room	-	4.7 x 7.5 x 2.7	4.7 x 7.5	-	-
No.8 measurement room	-	3.1 x 5.0 x 2.7	N/A	-	-
No.9 measurement room	-	8.8 x 4.6 x 2.8	2.4 x 2.4	-	-
No.11 measurement room	-	6.2 x 4.7 x 3.0	4.8 x 4.6	-	-

\* Size of vertical conducting plane (for Conducted Emission test) : 2.0 m x 2.0m for No.1, No.2, No.3, and No.4 semi-anechoic chambers and No.3 and No.4 shielded rooms.

### 3.6 Test data, Test instruments, and Test set up

Refer to APPENDIX.

## **SECTION 4: Operation of E.U.T. during testing**

### **4.1 Operating Mode(s)**

Test operating mode was determined as follows according to “Section 1 of 6 802.11 a/b/g/n testing - Managing Complex Regulatory Approvals - ” of TCB Council Workshop October 2009.

<b>Mode</b>	<b>Remarks*</b>
IEEE 802.11b (11b)	11 Mbps, PN9
IEEE 802.11g (11g)	6 Mbps, PN9
IEEE 802.11n 20 MHz BW (11n-20)	MCS 0 (Short GI), PN9
Bluetooth Low Energy (BT LE)	-
*The worst condition was determined based on the test result of Maximum Peak Output Power (Mid Channel)	
*The power value of the EUT was set for testing as follows (setting value might be different from product specification value); Power settings: WLAN: Same as production model BT LE: 2 dBm Software: bcm43455c0 *This setting of software is the worst case. Any conditions under the normal use do not exceed the condition of setting. In addition, end users cannot change the settings of the output power of the product.	

\*The details of Operating mode(s)

<b>Test Item</b>	<b>Operating Mode</b>	<b>Tested frequency</b>
Conducted Spurious Emission, Radiated Spurious Emission (Below 1GHz)	11g Tx *1)	2462 MHz
	BT LE Tx	2402 MHz 2440 MHz 2480 MHz
	11b Tx	2412 MHz
	11g Tx *2)	2437 MHz 2462 MHz
Radiated Spurious Emission (Above 1GHz)	11n-20 Tx *3)	2412 MHz 2462 MHz
	BT LE Tx	2402 MHz 2440 MHz 2480 MHz
	11b Tx	2412 MHz
	11g Tx	2437 MHz
6dB Bandwidth Maximum Peak Output Power Power Density 99% Occupied Bandwidth	11n-20 Tx	2462 MHz
	BT LE Tx	2402 MHz 2440 MHz 2480 MHz

\*1) The mode was tested as a representative, because it had the highest power at antenna terminal test.

\*2) Since 11g and 11n-20 have the same modulation method and no differences in transmitting specification, test was performed on the representative mode that had the highest peak output power.

\*3) 11n-20 was only tested for band-edge.

**UL Japan, Inc.**

**Ise EMC Lab.**

4383-326 Asama-cho, Ise-shi, Mie-ken 516-0021 JAPAN

Telephone : +81 596 24 8999

Facsimile : +81 596 24 8124

## 4.2 Configuration and peripherals

### For Radiated Spurious Emission test

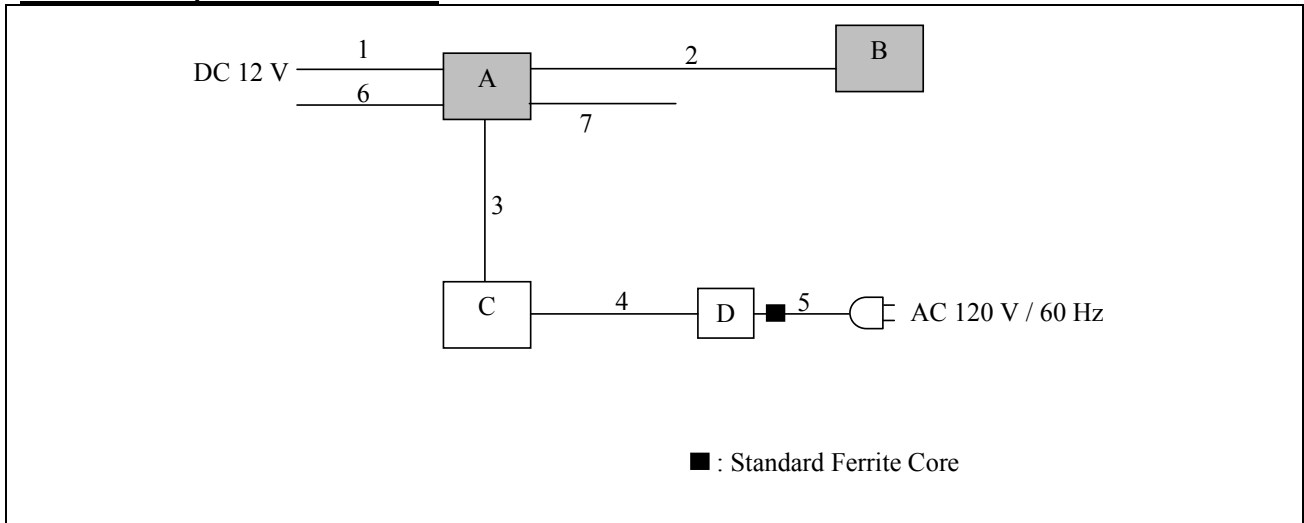

\* Cabling and setup(s) were taken into consideration and test data was taken under worse case conditions.

### Description of EUT and Support equipment

No.	Item	Model number	Serial number	Manufacturer	Remarks
A	Common Trigger Box	WV-TW37003	001	Panasonic System Networks Co., Ltd.	EUT
B	Antenna	AP-W-M-S2-R P-WH	001	ANTENNA PLUS	EUT
C	Laptop PC	T60	L3-DM302	IBM	-
D	AC Adapter	92P1160	11S92P1160Z1ZBGH6B6DKV	IBM	-

### List of cables used

No.	Name	Length (m)	Shield		Remarks
			Cable	Connector	
1	DC Cable	2.0	Unshielded	Unshielded	-
2	Antenna Cable	3.0	Shielded	Shielded	-
3	LAN Cable	3.0	Unshielded	Unshielded	-
4	DC Cable	1.8	Unshielded	Unshielded	-
5	AC Cable	0.9	Unshielded	Unshielded	-
6	Signal Cable	1.0	Unshielded	Unshielded	-
7	Flat Cable	0.12	Unshielded	Unshielded	-

**UL Japan, Inc.**

**Ise EMC Lab.**

4383-326 Asama-cho, Ise-shi, Mie-ken 516-0021 JAPAN

Telephone : +81 596 24 8999

Facsimile : +81 596 24 8124

**For Antenna Terminal Conducted Tests**

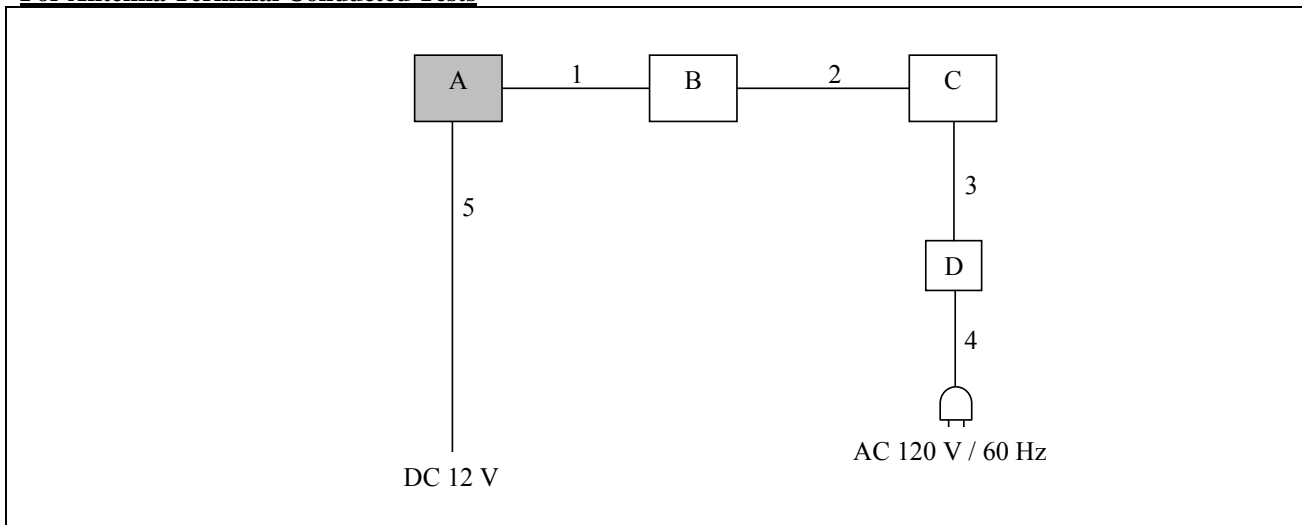

\* Cabling and setup(s) were taken into consideration and test data was taken under worse case conditions.

**Description of EUT and Support equipment**

No.	Item	Model number	Serial number	Manufacturer	Remarks
A	Common Trigger Box	WV-TW37003	002	Panasonic System Networks Co., Ltd.	EUT
B	Jig	-	-	-	-
C	Laptop PC	T450	0715PC06BG66	Lenovo	-
D	AC Adapter	ADLX65NCC2A	11S45N0263Z1ZS995578FZ	Lenovo	-

**List of cables used**

No.	Name	Length (m)	Shield		Remarks
			Cable	Connector	
1	Flat Cable	0.12	Unshielded	Unshielded	-
2	USB Cable	0.7	Unshielded	Unshielded	-
3	DC Cable	1.6	Unshielded	Unshielded	-
4	AC Cable	0.8	Unshielded	Unshielded	-
5	DC Cable	0.6	Unshielded	Unshielded	-

**UL Japan, Inc.**

**Ise EMC Lab.**

4383-326 Asama-cho, Ise-shi, Mie-ken 516-0021 JAPAN

Telephone : +81 596 24 8999

Facsimile : +81 596 24 8124

## **SECTION 5: Radiated Spurious Emission**

### **Test Procedure**

It was measured based on "11.0 Emissions in non-restricted frequency bands" of "558074 D01 DTS Meas Guidance v03r05".

[For below 1 GHz]

EUT was placed on a urethane platform of nominal size, 1.0 m by 1.5 m, raised 0.8 m above the conducting ground plane. The Radiated Electric Field Strength has been measured in a Semi Anechoic Chamber with a ground plane.

[For above 1 GHz]

EUT was placed on a urethane platform of nominal size, 0.5 m by 0.5 m, raised 1.5 m above the conducting ground plane.

The Radiated Electric Field Strength has been measured in a Semi Anechoic Chamber with absorbent materials lined on a ground plane.

The height of the measuring antenna varied between 1 and 4 m and EUT was rotated a full revolution in order to obtain the maximum value of the electric field strength.

The measurements were performed for both vertical and horizontal antenna polarization with the Test Receiver, or the Spectrum Analyzer.

The measurements were made with the following detector function of the test receiver and the Spectrum analyzer (in linear mode).

The test was made with the detector (RBW/VBW) in the following table.

When using Spectrum analyzer, the test was made with adjusting span to zero by using peak hold.

### **Test Antennas are used as below;**

Frequency	30 MHz to 200 MHz	200 MHz to 1 GHz	Above 1 GHz
Antenna Type	Biconical	Logperiodic	Horn

In any 100 kHz bandwidth outside the restricted band in which the spread spectrum intentional radiator is operating, the radio frequency power that is produced by the intentional radiator confirmed 20 dB below that in the 100 kHz bandwidth within the band that contains the highest level of the desired power, based on a radiated measurement.

### **20 dBc was applied to the frequency over the limit of FCC 15.209 / Table 4 of RSS-Gen 8.9(IC) and outside the restricted band of FCC15.205 / Table 6 of RSS-Gen 8.10 (IC).**

Frequency	Below 1 GHz	Above 1 GHz		20 dBc
Instrument used	Test Receiver	Spectrum Analyzer		Spectrum Analyzer
Detector	QP	PK	AV *1)	PK
IF Bandwidth	BW 120 kHz	RBW: 1 MHz VBW: 3 MHz	Average Power Method: RBW: 1 MHz VBW: 3 MHz Detector: Power Averaging (RMS) Trace: 100 traces If duty cycle was less than 98%, a duty factor was added to the results.	RBW: 100 kHz VBW: 300kHz
Test Distance	3 m	4.45 m *2) (1 GHz – 10 GHz), 1 m *3) (10 GHz – 26.5 GHz)		4.45 m *2) (1 GHz – 10 GHz), 1 m *3) (10 GHz – 26.5 GHz)

\*1) Average Power Measurement was performed based on 6.0 & 12.2.5 of "KDB 558074 D01 DTS Meas Guidance v03r05".

\*2) Distance Factor:  $20 \times \log(4.45 \text{ m} / 3.0 \text{ m}) = 3.43 \text{ dB}$

\*3) Distance Factor:  $20 \times \log(1.0 \text{ m} / 3.0 \text{ m}) = -9.5 \text{ dB}$

## **UL Japan, Inc.**

### **Ise EMC Lab.**

4383-326 Asama-cho, Ise-shi, Mie-ken 516-0021 JAPAN

Telephone : +81 596 24 8999

Facsimile : +81 596 24 8124

- The carrier level and noise levels were confirmed at each position of X, Y and Z axes of EUT (Common Trigger Box and antenna) to see the position of maximum noise, and the test was made at the position that has the maximum noise.

The test results and limit are rounded off to one decimal place, so some differences might be observed.

**Measurement range** : 30 MHz - 26.5 GHz  
**Test data** : APPENDIX  
**Test result** : Pass

## **SECTION 6: Antenna Terminal Conducted Tests**

### **Test Procedure**

The tests were made with below setting connected to the antenna port.

<b>Test</b>	<b>Span</b>	<b>RBW</b>	<b>VBW</b>	<b>Sweep time</b>	<b>Detector</b>	<b>Trace</b>	<b>Instrument used</b>
6dB Bandwidth	20 MHz	100 kHz	300 kHz	Auto	Peak	Max Hold	Spectrum Analyzer
99% Occupied Bandwidth *1)	Enough width to display emission skirts	1 to 5 % of OBW	Three times of RBW	Auto	Peak	Max Hold	Spectrum Analyzer
Maximum Peak Output Power	-	-	-	Auto	Peak/Average *2)	-	Power Meter (Sensor: 50 MHz BW)
Peak Power Density	1.5 times the 6dB Bandwidth	3 kHz	10 kHz	Auto	Peak	Max Hold	Spectrum Analyzer *3)
Conducted Spurious Emission	9kHz to 150kHz	200 Hz	620 Hz	Auto	Peak	Max Hold	Spectrum Analyzer
	150kHz to 30MHz	9.1 kHz	27 kHz				
*1) Peak hold was applied as Worst-case measurement. *2) Reference data *3) Section 10.2 Method PKPSD (peak PSD) of "KDB 558074 D01 DTS Meas Guidance v03r05". *4) In the frequency range below 30MHz, RBW was narrowed to separate the noise contents. Then, wide-band noise near the limit was checked separately, however the noise was not detected as shown in the chart. (9 kHz - 150 kHz: RBW = 200 Hz, 150 kHz - 30 MHz: RBW = 9.1 kHz)							

The test results and limit are rounded off to two decimals place, so some differences might be observed.

**Test data** : **APPENDIX**  
**Test result** : **Pass**

**UL Japan, Inc.**

**Ise EMC Lab.**

4383-326 Asama-cho, Ise-shi, Mie-ken 516-0021 JAPAN

Telephone : +81 596 24 8999

Facsimile : +81 596 24 8124

## APPENDIX 1: Test data

### 6dB Bandwidth

Test place Ise EMC Lab. No.6 Measurement Room  
Report No. 11500829H  
Date December 13, 2016  
Temperature / Humidity 24 deg. C / 31 % RH  
Engineer Yutaka Yoshida  
Mode Tx

Mode	Frequency [MHz]	6dB Bandwidth [MHz]	Limit [kHz]
11b	2412	8.329	> 500
	2437	8.197	> 500
	2462	8.277	> 500
11g	2412	16.340	> 500
	2437	15.693	> 500
	2462	15.479	> 500
11n-20	2412	17.426	> 500
	2437	16.332	> 500
	2462	15.802	> 500
BT LE	2402	0.718	> 500
	2440	0.713	> 500
	2480	0.717	> 500

### 6dB Bandwidth

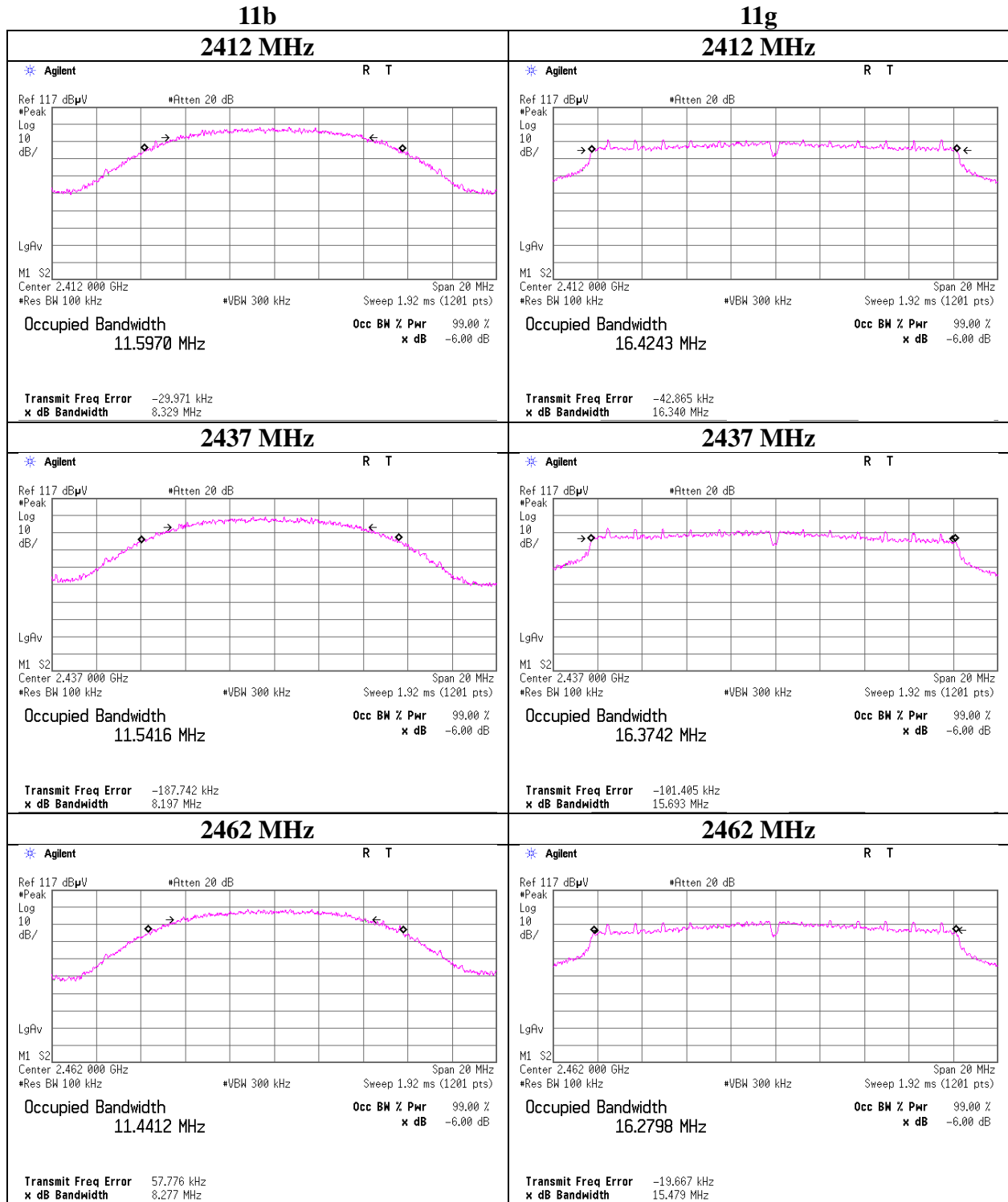

### 6dB Bandwidth

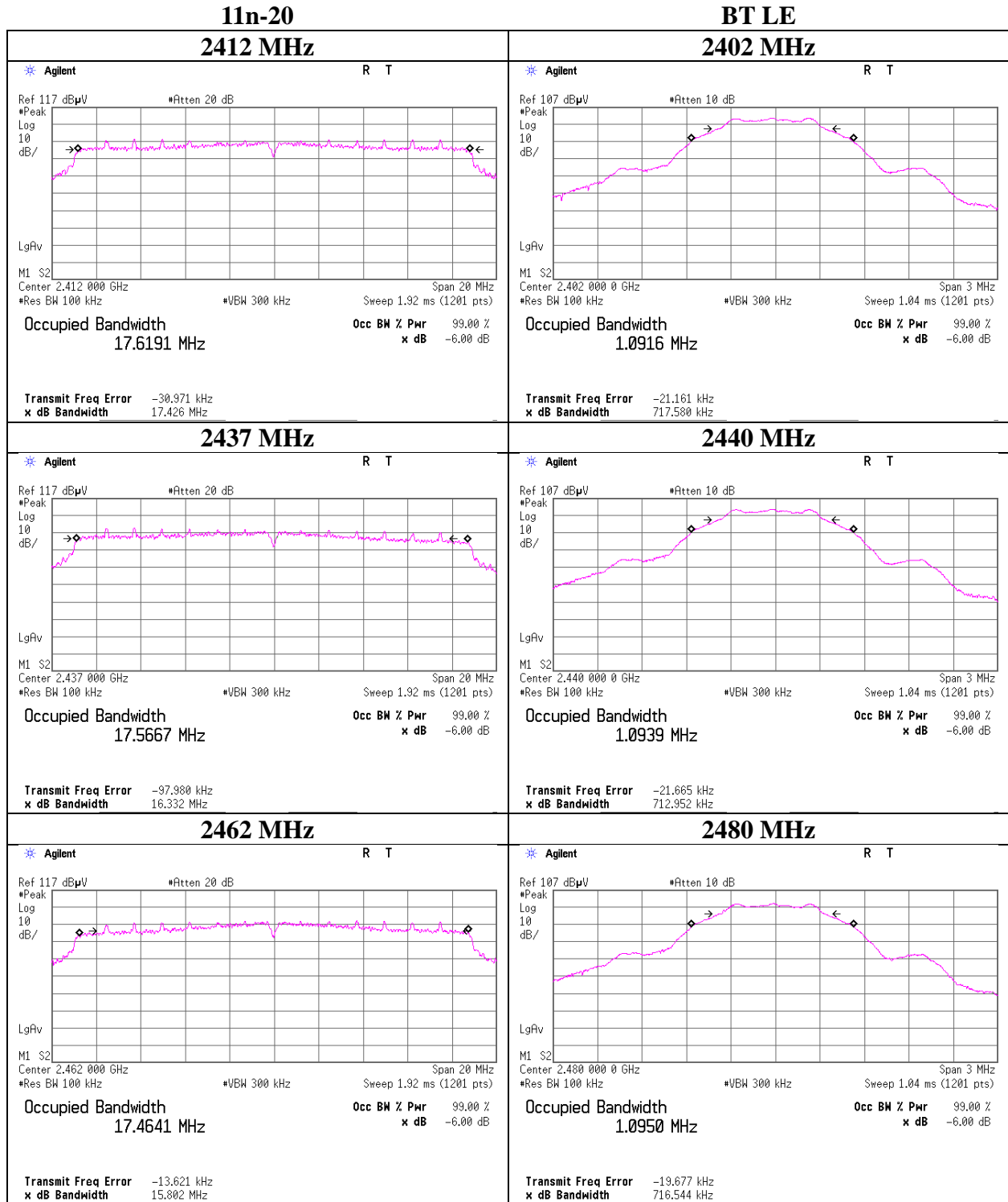

**UL Japan, Inc.**

**Ise EMC Lab.**

4383-326 Asama-cho, Ise-shi, Mie-ken 516-0021 JAPAN

Telephone : +81 596 24 8999

Facsimile : +81 596 24 8124

### Maximum Peak Output Power

Test place : Ise EMC Lab. No.6 Measurement Room  
Report No. : 11500829H  
Date : December 13, 2016  
Temperature / Humidity : 24 deg. C / 31 % RH  
Engineer : Yutaka Yoshida  
Mode : Tx 11b

11Mbps

Freq. [MHz]	Reading [dBm]	Cable Loss [dB]	Atten. Loss [dB]	Result		Limit		Margin [dB]
				[dBm]	[mW]	[dBm]	[mW]	
2412	9.50	1.51	10.06	21.07	127.94	30.00	1000	8.93
2437	10.26	1.52	10.06	21.84	152.76	30.00	1000	8.16
2462	10.22	1.52	10.06	21.80	151.36	30.00	1000	8.20

Sample Calculation:

Result = Reading + Cable Loss (including the cable(s) customer supplied) + Attenuator Loss

2437MHz

Rate [Mbps]	Reading [dBm]	Remark
1	9.54	
2	10.06	
5.5	10.10	
11	10.26	*

\*: Worst Rate

All comparison were carried out on same frequency and measurement factors.

### Maximum Peak Output Power

Test place	Ise EMC Lab. No.6 Measurement Room
Report No.	11500829H
Date	December 13, 2016
Temperature / Humidity	24 deg. C / 31 % RH
Engineer	Yutaka Yoshida
Mode	Tx 11g

6Mbps

Freq. [MHz]	Reading [dBm]	Cable Loss [dB]	Atten. Loss [dB]	Result		Limit		Margin [dB]
				[dBm]	[mW]	[dBm]	[mW]	
2412	12.74	1.51	10.06	24.31	269.77	30.00	1000	5.69
2437	13.09	1.52	10.06	24.67	293.09	30.00	1000	5.33
2462	13.42	1.52	10.06	25.00	316.23	30.00	1000	5.00

Sample Calculation:

Result = Reading + Cable Loss (including the cable(s) customer supplied) + Attenuator Loss

2437MHz

Rate [Mbps]	Reading [dBm]	Remark
6	13.09	*
9	13.01	
12	12.80	
18	12.83	
24	12.58	
36	12.76	
48	12.93	
54	12.27	

\*: Worst Rate

All comparison were carried out on same frequency and measurement factors.

## Maximum Peak Output Power

Test place	Ise EMC Lab. No.6 Measurement Room
Report No.	11500829H
Date	December 13, 2016
Temperature / Humidity	24 deg. C / 31 % RH
Engineer	Yutaka Yoshida
Mode	Tx 11n-20

### MCS0 Short GI

Freq. [MHz]	Reading [dBm]	Cable Loss [dB]	Atten. Loss [dB]	Result		Limit		Margin [dB]
				[dBm]	[mW]	[dBm]	[mW]	
2412	12.70	1.51	10.06	24.27	267.30	30.00	1000	5.73
2437	13.07	1.52	10.06	24.65	291.74	30.00	1000	5.35
2462	13.22	1.52	10.06	24.80	302.00	30.00	1000	5.20

Sample Calculation:

Result = Reading + Cable Loss (including the cable(s) customer supplied) + Attenuator Loss

2437MHz

Short GI

MCS Index Number	Reading [dBm]	Remark
0	13.07	*
1	12.98	
2	12.85	
3	12.97	
4	12.75	
5	12.82	
6	12.82	
7	12.78	

Long GI

MCS Index Number	Reading [dBm]	Remark
0	13.05	
1	12.93	
2	12.91	
3	12.99	
4	12.89	
5	12.70	
6	12.75	
7	12.71	

\*: Worst Rate

All comparison were carried out on same frequency and measurement factors.

### Maximum Peak Output Power

Test place Ise EMC Lab. No.6 Measurement Room  
Report No. 11500829H  
Date December 13, 2016  
Temperature / Humidity 24 deg. C / 31 % RH  
Engineer Yutaka Yoshida  
Mode Tx BT LE

Freq. [MHz]	Reading [dBm]	Cable Loss [dB]	Atten. Loss [dB]	Result		Limit		Margin [dB]
				[dBm]	[mW]	[dBm]	[mW]	
2402	-5.99	1.51	10.06	5.58	3.61	30.00	1000	24.42
2440	-5.94	1.52	10.06	5.64	3.66	30.00	1000	24.36
2480	-7.49	1.53	10.06	4.10	2.57	30.00	1000	25.90

Sample Calculation:

Result = Reading + Cable Loss (including the cable(s) customer supplied) + Attenuator Loss

**Average Output Power**  
**(Reference data for RF Exposure)**

Test place : Ise EMC Lab. No.6 Measurement Room  
Report No. : 11500829H  
Date : December 13, 2016  
Temperature / Humidity : 24 deg. C / 31 % RH  
Engineer : Yutaka Yoshida  
Mode : Tx

**11b 1 Mbps**

Freq. [MHz]	Reading [dBm]	Cable Loss [dB]	Atten. Loss [dB]	Result (Time average)		Duty factor [dB]	Result (Burst power average)	
				[dBm]	[mW]		[dBm]	[mW]
2412	5.86	1.51	10.06	17.43	55.34	0.05	17.48	55.98
2437	6.55	1.52	10.06	18.13	65.01	0.05	18.18	65.77
2462	6.46	1.52	10.06	18.04	63.68	0.05	18.09	64.42

**11g 6 Mbps**

Freq. [MHz]	Reading [dBm]	Cable Loss [dB]	Atten. Loss [dB]	Result (Time average)		Duty factor [dB]	Result (Burst power average)	
				[dBm]	[mW]		[dBm]	[mW]
2412	2.48	1.51	10.06	14.05	25.41	0.29	14.34	27.16
2437	3.29	1.52	10.06	14.87	30.69	0.29	15.16	32.81
2462	3.28	1.52	10.06	14.86	30.62	0.29	15.15	32.73

**11n-20 MCS 0 Short GI**

Freq. [MHz]	Reading [dBm]	Cable Loss [dB]	Atten. Loss [dB]	Result (Time average)		Duty factor [dB]	Result (Burst power average)	
				[dBm]	[mW]		[dBm]	[mW]
2412	2.06	1.51	10.06	13.63	23.07	0.35	13.98	25.00
2437	2.81	1.52	10.06	14.39	27.48	0.35	14.74	29.79
2462	2.83	1.52	10.06	14.41	27.61	0.35	14.76	29.92

**BT LE**

Freq. [MHz]	Reading [dBm]	Cable Loss [dB]	Atten. Loss [dB]	Result (Time average)		Duty factor [dB]	Result (Burst power average)	
				[dBm]	[mW]		[dBm]	[mW]
2402	-9.93	1.51	10.06	1.64	1.46	3.61	5.25	3.35
2440	-9.86	1.52	10.06	1.72	1.49	3.61	5.33	3.41
2480	-11.56	1.53	10.06	0.03	1.01	3.61	3.64	2.31

Sample Calculation:

Result (Time average) = Reading + Cable Loss (including the cable(s) customer supplied) + Attenuator Loss  
Result (Burst power average) = Time average + Duty factor

**The average output power was measured with the lowest order modulation and lowest data rate configuration in each IEEE 802.11 mode based on KDB 248227 D01.**

### Burst rate confirmation

Test place	Ise EMC Lab. No.6 Measurement Room
Report No.	11500829H
Date	December 13, 2016
Temperature / Humidity	24 deg. C / 31 % RH
Engineer	Yutaka Yoshida
Mode	Tx

#### 11b 1 Mbps

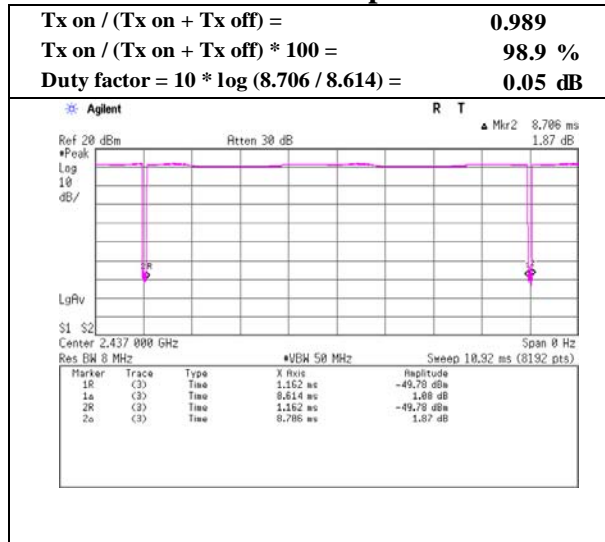

#### 11b 11 Mbps

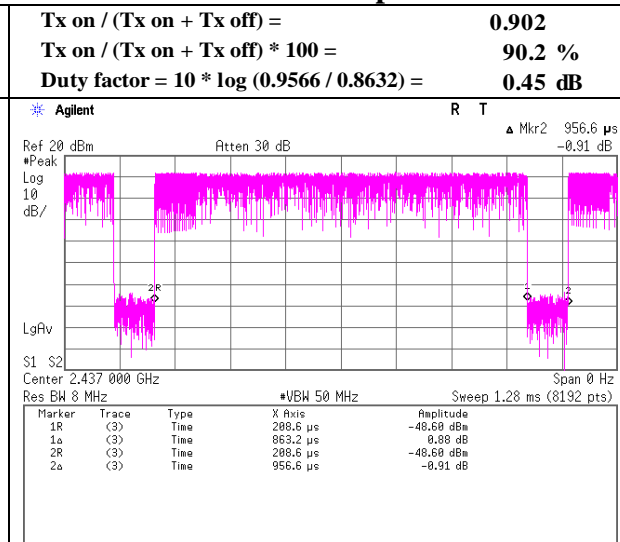

### Burst rate confirmation

Test place	Ise EMC Lab. No.6 Measurement Room
Report No.	11500829H
Date	December 13, 2016
Temperature / Humidity	24 deg. C / 31 % RH
Engineer	Yutaka Yoshida
Mode	Tx

#### 11g 6Mbps

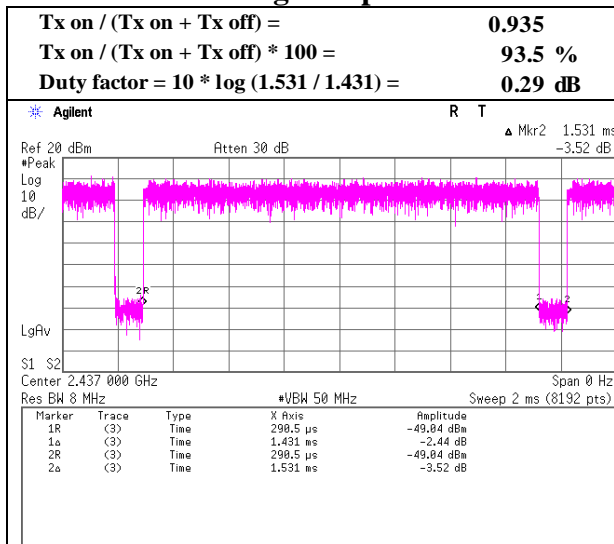

#### 11n-20 MCS 0 Short GI

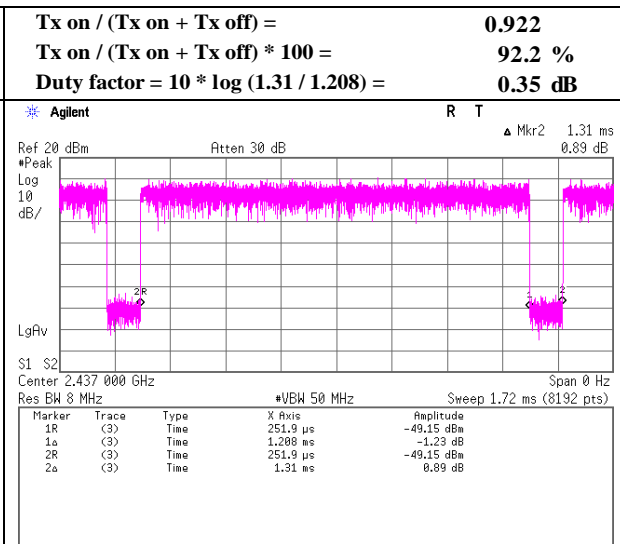

#### BT LE

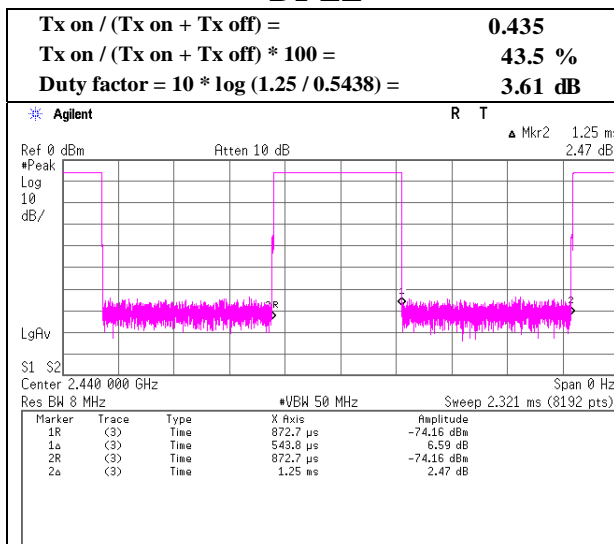

## Radiated Spurious Emission

Test place	Ise EMC Lab. No.3 Semi Anechoic Chamber		
Report No.	11500829H		
Date	December 20, 2016	December 21, 2016	December 21, 2016
Temperature / Humidity	25 deg. C / 37 % RH	21 deg. C / 34 % RH	25deg. C / 33 % RH
Engineer	Takumi Shimada	Ken Fujita	Tomoki Matsui
	(1 GHz -10 GHz)	(10 GHz - 18 GHz)	(18 GHz - 26.5 GHz)
Mode	Tx 11b 2412 MHz		

Polarity	Frequency [MHz]	Detector	Reading [dBuV]	Ant.Fac. [dB/m]	Loss [dB]	Gain [dB]	Duty Factor [dB]	Result [dBuV/m]	Limit [dBuV/m]	Margin [dB]	Remark
Hori	1050.000	PK	57.7	23.7	5.7	35.2	-	51.9	73.9	22.0	
Hori	1150.000	PK	56.7	24.1	5.8	34.9	-	51.7	73.9	22.2	
Hori	1250.000	PK	52.5	24.4	5.9	34.6	-	48.2	73.9	25.7	
Hori	2390.000	PK	57.1	26.7	6.8	32.7	-	57.9	73.9	16.0	
Hori	4824.000	PK	40.4	31.1	9.0	31.8	-	48.7	73.9	25.2	Floor noise
Hori	7236.000	PK	40.9	35.7	10.3	32.6	-	54.3	73.9	19.6	Floor noise
Hori	9648.000	PK	41.9	37.2	10.9	33.3	-	56.7	73.9	17.2	Floor noise
Hori	1050.000	AV	56.2	23.7	5.7	35.2	-	50.4	53.9	3.5	
Hori	1150.000	AV	55.2	24.1	5.8	34.9	-	50.2	53.9	3.7	
Hori	1250.000	AV	50.3	24.4	5.9	34.6	-	46.0	53.9	7.9	
Hori	2390.000	AV	46.6	26.7	6.8	32.7	0.5	47.9	53.9	6.1	*1)
Hori	4824.000	AV	29.9	31.1	9.0	31.8	-	38.2	53.9	15.7	Floor noise
Hori	7236.000	AV	30.9	35.7	10.3	32.6	-	44.3	53.9	9.6	Floor noise
Hori	9648.000	AV	30.8	37.2	10.9	33.3	-	45.6	53.9	8.3	Floor noise
Vert	1050.000	PK	53.1	23.7	5.7	35.2	-	47.3	73.9	26.6	
Vert	1150.000	PK	57.1	24.1	5.8	34.9	-	52.1	73.9	21.8	
Vert	1250.000	PK	53.1	24.4	5.9	34.6	-	48.8	73.9	25.1	
Vert	2390.000	PK	54.1	26.7	6.8	32.7	-	54.9	73.9	19.0	
Vert	4824.000	PK	40.8	31.1	9.0	31.8	-	49.1	73.9	24.8	Floor noise
Vert	7236.000	PK	41.3	35.7	10.3	32.6	-	54.7	73.9	19.2	Floor noise
Vert	9648.000	PK	41.2	37.2	10.9	33.3	-	56.0	73.9	17.9	Floor noise
Vert	1050.000	AV	50.1	23.7	5.7	35.2	-	44.3	53.9	9.6	
Vert	1150.000	AV	55.6	24.1	5.8	34.9	-	50.6	53.9	3.3	
Vert	1250.000	AV	50.4	24.4	5.9	34.6	-	46.1	53.9	7.8	
Vert	2390.000	AV	45.6	26.7	6.8	32.7	0.5	46.9	53.9	7.1	*1)
Vert	4824.000	AV	31.0	31.1	9.0	31.8	-	39.3	53.9	14.6	Floor noise
Vert	7236.000	AV	32.7	35.7	10.3	32.6	-	46.1	53.9	7.8	Floor noise
Vert	9648.000	AV	32.6	37.2	10.9	33.3	-	47.4	53.9	6.5	Floor noise

Result = Reading + Ant Factor + Loss (Cable+Attenuator+Filter+Distance factor(above 1 GHz)) - Gain(Amplifier) + Duty factor

\*Other frequency noises omitted in this report were not seen or had enough margin (more than 20 dB).

Distance factor: 1 GHz - 10 GHz 20log(4.45 m / 3.0 m) = 3.43 dB  
10 GHz - 26.5 GHz 20log(1.0 m / 3.0 m) = -9.5 dB

\*1) Not Out of Band emission(Leakage Power)

### 20dBc Data Sheet

Polarity	Frequency [MHz]	Detector	Reading [dBuV]	Ant Factor [dB/m]	Loss [dB]	Gain [dB]	Result [dBuV/m]	Limit [dBuV/m]	Margin [dB]	Remark
Hori	2412.000	PK	107.0	26.7	6.8	32.7	107.8	-	-	Carrier
Hori	2400.000	PK	66.6	26.7	6.8	32.7	67.4	87.8	20.4	-
Vert	2412.000	PK	103.8	26.7	6.8	32.7	104.6	-	-	Carrier
Vert	2400.000	PK	63.7	26.7	6.8	32.7	64.5	84.6	20.1	-

Result = Reading + Ant Factor + Loss (Cable+Attenuator+Filter+Distance factor(above 1 GHz)) - Gain(Amplifier)

**UL Japan, Inc.**

**Ise EMC Lab.**

4383-326 Asama-cho, Ise-shi, Mie-ken 516-0021 JAPAN

Telephone : +81 596 24 8999

Facsimile : +81 596 24 8124

## Radiated Spurious Emission (Reference Plot for band-edge)

Test place	Ise EMC Lab. No.3 Semi Anechoic Chamber
Report No.	11500829H
Date	December 20, 2016
Temperature / Humidity	25 deg. C / 37 % RH
Engineer	Takumi Shimada (1 GHz -10 GHz)
Mode	Tx 11b 2412 MHz

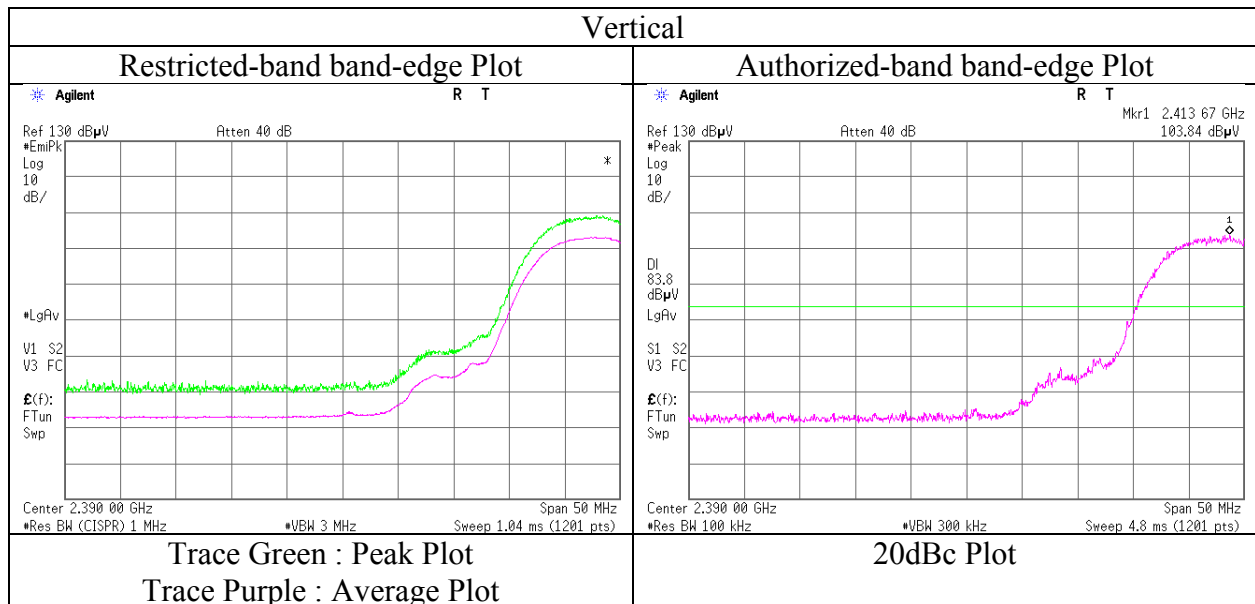
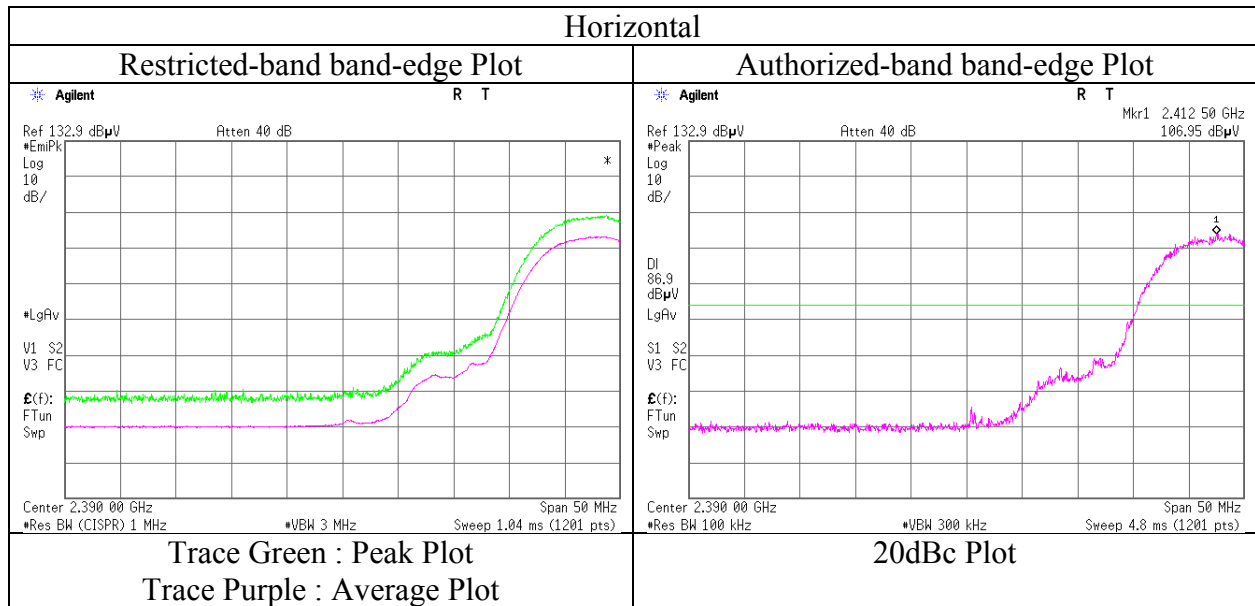

\* Final result of restricted band edge was shown in tabular data.

**UL Japan, Inc.**

**Ise EMC Lab.**

4383-326 Asama-cho, Ise-shi, Mie-ken 516-0021 JAPAN

Telephone : +81 596 24 8999

Facsimile : +81 596 24 8124

## Radiated Spurious Emission

Test place	Ise EMC Lab. No.3 Semi Anechoic Chamber		
Report No.	11500829H		
Date	December 20, 2016	December 21, 2016	December 21, 2016
Temperature / Humidity	25 deg. C / 37 % RH	21 deg. C / 34 % RH	25deg. C / 33 % RH
Engineer	Takumi Shimada	Ken Fujita	Tomoki Matsui
	(1 GHz -10 GHz)	(10 GHz - 18 GHz)	(18 GHz - 26.5 GHz)
Mode	Tx 11b 2437 MHz		

Polarity	Frequency [MHz]	Detector	Reading [dBuV]	Ant.Fac. [dB/m]	Loss [dB]	Gain [dB]	Duty Factor [dB]	Result [dBuV/m]	Limit [dBuV/m]	Margin [dB]	Remark
Hori	1050.000	PK	57.1	23.7	5.7	35.2	-	51.3	73.9	22.6	
Hori	1150.000	PK	57.5	24.1	5.8	34.9	-	52.5	73.9	21.4	
Hori	1250.000	PK	51.5	24.4	5.9	34.6	-	47.2	73.9	26.7	
Hori	4874.000	PK	39.7	31.2	9.0	31.7	-	48.2	73.9	25.7	Floor noise
Hori	7311.000	PK	40.9	35.6	10.3	32.6	-	54.2	73.9	19.7	Floor noise
Hori	9748.000	PK	40.1	37.2	10.9	33.3	-	54.9	73.9	19.0	Floor noise
Hori	1050.000	AV	55.4	23.7	5.7	35.2	-	49.6	53.9	4.3	
Hori	1150.000	AV	55.6	24.1	5.8	34.9	-	50.6	53.9	3.3	
Hori	1250.000	AV	49.8	24.4	5.9	34.6	-	45.5	53.9	8.4	
Hori	4874.000	AV	31.2	31.2	9.0	31.7	-	39.7	53.9	14.2	Floor noise
Hori	7311.000	AV	31.9	35.6	10.3	32.6	-	45.2	53.9	8.7	Floor noise
Hori	9748.000	AV	32.2	37.2	10.9	33.3	-	47.0	53.9	6.9	Floor noise
Vert	1050.000	PK	54.2	23.7	5.7	35.2	-	48.4	73.9	25.5	
Vert	1150.000	PK	57.5	24.1	5.8	34.9	-	52.5	73.9	21.4	
Vert	1250.000	PK	54.0	24.4	5.9	34.6	-	49.7	73.9	24.2	
Vert	4874.000	PK	40.2	31.2	9.0	31.7	-	48.7	73.9	25.2	Floor noise
Vert	7311.000	PK	41.0	35.6	10.3	32.6	-	54.3	73.9	19.6	Floor noise
Vert	9748.000	PK	40.3	37.2	10.9	33.3	-	55.1	73.9	18.8	Floor noise
Vert	1050.000	AV	51.3	23.7	5.7	35.2	-	45.5	53.9	8.4	
Vert	1150.000	AV	55.8	24.1	5.8	34.9	-	50.8	53.9	3.1	
Vert	1250.000	AV	51.2	24.4	5.9	34.6	-	46.9	53.9	7.0	
Vert	4874.000	AV	31.7	31.2	9.0	31.7	-	40.2	53.9	13.7	Floor noise
Vert	7311.000	AV	32.3	35.6	10.3	32.6	-	45.6	53.9	8.3	Floor noise
Vert	9748.000	AV	32.2	37.2	10.9	33.3	-	47.0	53.9	6.9	Floor noise

Result = Reading + Ant Factor + Loss (Cable+Attenuator+Filter+Distance factor(above 1 GHz)) - Gain(Amplifier)

\*Other frequency noises omitted in this report were not seen or had enough margin (more than 20 dB).

Distance factor:     1 GHz - 10 GHz    20log (4.45 m / 3.0 m) = 3.43 dB  
                          10 GHz - 26.5 GHz 20log (1.0 m / 3.0 m) = -9.5 dB

## Radiated Spurious Emission

Test place : Ise EMC Lab. No.3 Semi Anechoic Chamber  
Report No. : 11500829H  
Date : December 20, 2016      December 21, 2016      December 21, 2016  
Temperature / Humidity : 25 deg. C / 37 % RH      21 deg. C / 34 % RH      25deg. C / 33 % RH  
Engineer : Takumi Shimada      Ken Fujita      Tomoki Matsui  
              (1 GHz -10 GHz)      (10 GHz - 18 GHz)      (18 GHz - 26.5 GHz)  
Mode : Tx 11b 2462 MHz

Polarity	Frequency [MHz]	Detector	Reading [dBuV]	Ant.Fac. [dB/m]	Loss [dB]	Gain [dB]	Duty Factor [dB]	Result [dBuV/m]	Limit [dBuV/m]	Margin [dB]	Remark
Hori	1050.000	PK	57.0	23.7	5.7	35.2	-	51.2	73.9	22.7	
Hori	1150.000	PK	57.9	24.1	5.8	34.9	-	52.9	73.9	21.0	
Hori	1250.000	PK	52.3	24.4	5.9	34.6	-	48.0	73.9	25.9	
Hori	2483.500	PK	55.8	26.8	6.9	32.6	-	56.9	73.9	17.0	
Hori	4924.000	PK	39.7	31.4	9.0	31.7	-	48.4	73.9	25.5	Floor noise
Hori	7386.000	PK	41.2	35.5	10.2	32.7	-	54.2	73.9	19.7	Floor noise
Hori	9848.000	PK	40.2	37.2	11.0	33.3	-	55.1	73.9	18.8	Floor noise
Hori	1050.000	AV	55.1	23.7	5.7	35.2	-	49.3	53.9	4.6	
Hori	1150.000	AV	56.6	24.1	5.8	34.9	-	51.6	53.9	2.3	
Hori	1250.000	AV	50.6	24.4	5.9	34.6	-	46.3	53.9	7.6	
Hori	2483.500	AV	48.2	26.8	6.9	32.6	0.5	49.8	53.9	4.1	*1)
Hori	4924.000	AV	29.0	31.4	9.0	31.7	-	37.7	53.9	16.2	Floor noise
Hori	7386.000	AV	30.3	35.5	10.2	32.7	-	43.3	53.9	10.6	Floor noise
Hori	9848.000	AV	30.1	37.2	11.0	33.3	-	45.0	53.9	8.9	Floor noise
Vert	1050.000	PK	55.1	23.7	5.7	35.2	-	49.3	73.9	24.6	
Vert	1150.000	PK	57.6	24.1	5.8	34.9	-	52.6	73.9	21.3	
Vert	1250.000	PK	53.9	24.4	5.9	34.6	-	49.6	73.9	24.3	
Vert	2483.500	PK	55.2	26.8	6.9	32.6	-	56.3	73.9	17.6	
Vert	4924.000	PK	40.7	31.4	9.0	31.7	-	49.4	73.9	24.5	Floor noise
Vert	7386.000	PK	40.9	35.5	10.2	32.7	-	53.9	73.9	20.0	Floor noise
Vert	9848.000	PK	40.3	37.2	11.0	33.3	-	55.2	73.9	18.7	Floor noise
Vert	1050.000	AV	52.8	23.7	5.7	35.2	-	47.0	53.9	6.9	
Vert	1150.000	AV	56.0	24.1	5.8	34.9	-	51.0	53.9	2.9	
Vert	1250.000	AV	51.1	24.4	5.9	34.6	-	46.8	53.9	7.1	
Vert	2483.500	AV	45.0	26.8	6.9	32.6	0.5	46.6	53.9	7.3	*1)
Vert	4924.000	AV	31.6	31.4	9.0	31.7	-	40.3	53.9	13.6	Floor noise
Vert	7386.000	AV	32.2	35.5	10.2	32.7	-	45.2	53.9	8.7	Floor noise
Vert	9848.000	AV	31.7	37.2	11.0	33.3	-	46.6	53.9	7.3	Floor noise

Result = Reading + Ant Factor + Loss (Cable+Attenuator+Filter+Distance factor(above 1 GHz)) - Gain(Amplifier) + Duty factor

\*Other frequency noises omitted in this report were not seen or had enough margin (more than 20 dB).

Distance factor:      1 GHz - 10 GHz      20log(4.45 m / 3.0 m) = 3.43 dB  
                              10 GHz - 26.5 GHz 20log(1.0 m / 3.0 m) = -9.5 dB

\*1) Not Out of Band emission(Leakage Power)

**Radiated Spurious Emission**  
**(Reference Plot for band-edge)**

Test place	Ise EMC Lab. No.3 Semi Anechoic Chamber
Report No.	11500829H
Date	December 20, 2016
Temperature / Humidity	25 deg. C / 37 % RH
Engineer	Takumi Shimada (1 GHz -10 GHz)
Mode	Tx 11b 2462 MHz

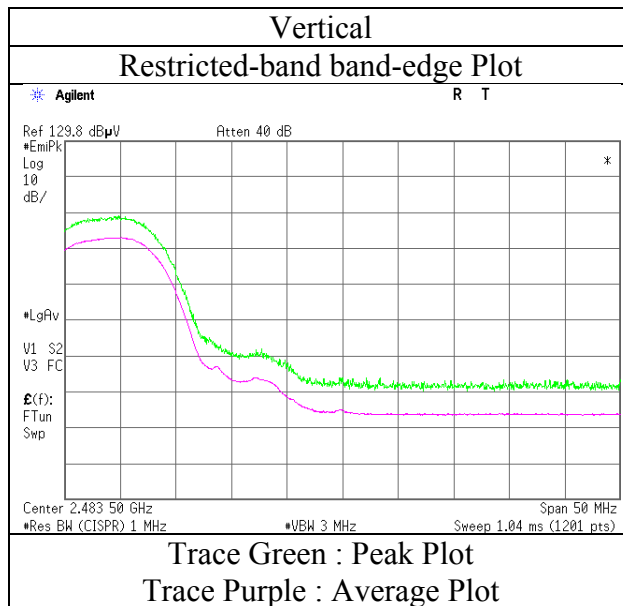
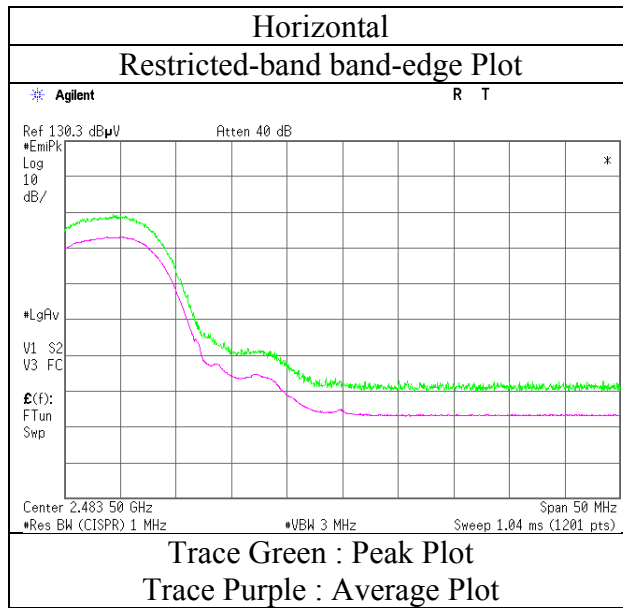

\* Final result of restricted band edge was shown in tabular data.



## Radiated Spurious Emission (Reference Plot for band-edge)

Test place	Ise EMC Lab. No.3 Semi Anechoic Chamber
Report No.	11500829H
Date	December 20, 2016
Temperature / Humidity	25 deg. C / 37 % RH
Engineer	Takumi Shimada
	(1 GHz -10 GHz)
Mode	Tx 11g 2412 MHz

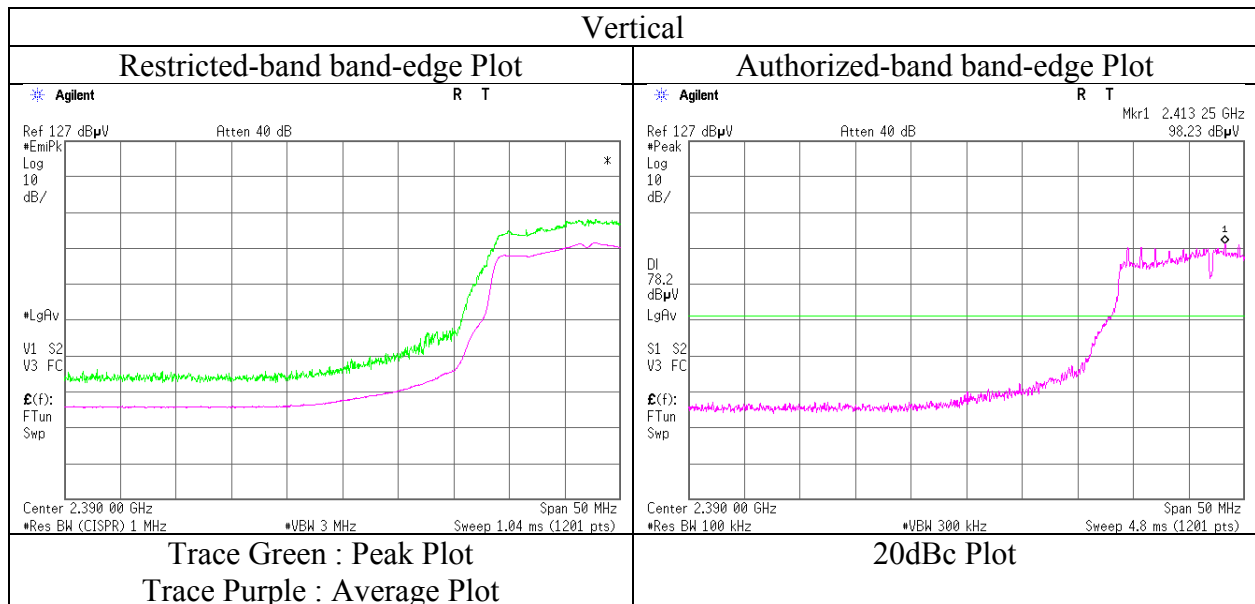
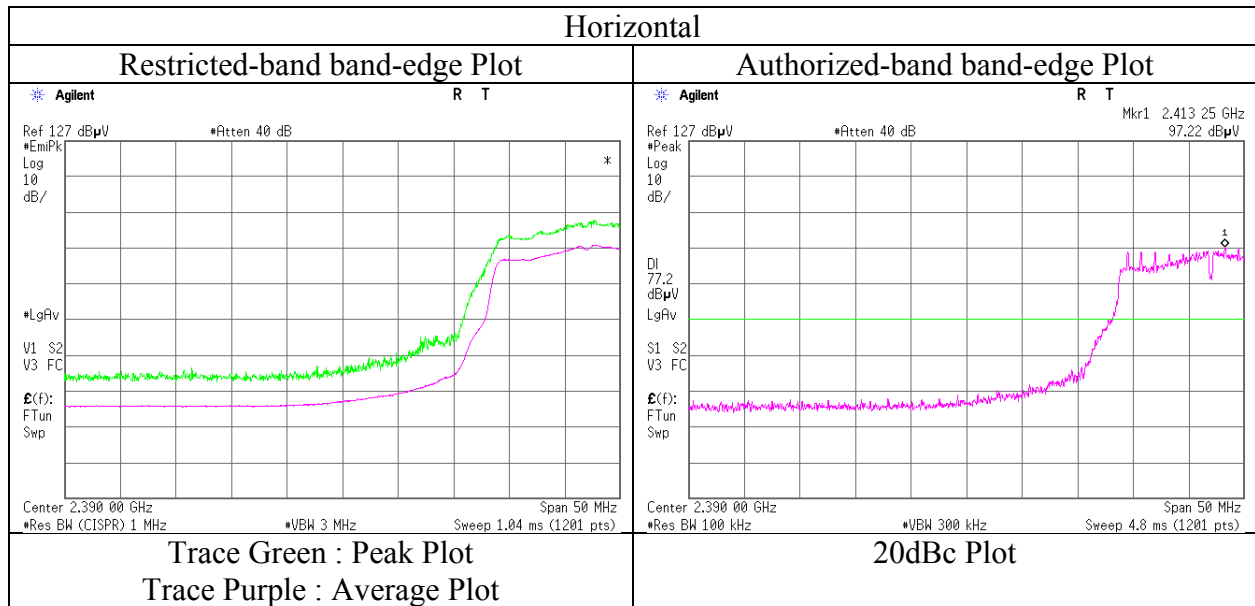

\* Final result of restricted band edge was shown in tabular data.

**UL Japan, Inc.**

**Ise EMC Lab.**

4383-326 Asama-cho, Ise-shi, Mie-ken 516-0021 JAPAN

Telephone : +81 596 24 8999

Facsimile : +81 596 24 8124

## Radiated Spurious Emission

Test place	Ise EMC Lab. No.3 Semi Anechoic Chamber		
Report No.	11500829H		
Date	December 20, 2016	December 21, 2016	December 21, 2016
Temperature / Humidity	25 deg. C / 37 % RH	21 deg. C / 34 % RH	25deg. C / 33 % RH
Engineer	Takumi Shimada	Ken Fujita	Tomoki Matsui
	(1 GHz -10 GHz)	(10 GHz - 18 GHz)	(18 GHz - 26.5 GHz)
Mode	Tx 11g 2437 MHz		

Polarity	Frequency [MHz]	Detector	Reading [dBuV]	Ant.Fac. [dB/m]	Loss [dB]	Gain [dB]	Duty Factor [dB]	Result [dBuV/m]	Limit [dBuV/m]	Margin [dB]	Remark
Hori	1050.000	PK	55.1	23.7	5.7	35.2	-	49.3	73.9	24.6	
Hori	1150.000	PK	54.5	24.1	5.8	34.9	-	49.5	73.9	24.4	
Hori	1250.000	PK	50.1	24.4	5.9	34.6	-	45.8	73.9	28.1	
Hori	4874.000	PK	40.6	31.2	9.0	31.7	-	49.1	73.9	24.8	Floor noise
Hori	7311.000	PK	40.2	35.6	10.3	32.6	-	53.5	73.9	20.4	Floor noise
Hori	9748.000	PK	40.4	37.2	10.9	33.3	-	55.2	73.9	18.7	Floor noise
Hori	1050.000	AV	52.3	23.7	5.7	35.2	-	46.5	53.9	7.4	
Hori	1150.000	AV	51.5	24.1	5.8	34.9	-	46.5	53.9	7.4	
Hori	1250.000	AV	48.7	24.4	5.9	34.6	-	44.4	53.9	9.5	
Hori	4874.000	AV	30.5	31.2	9.0	31.7	-	39.0	53.9	14.9	Floor noise
Hori	7311.000	AV	31.3	35.6	10.3	32.6	-	44.6	53.9	9.3	Floor noise
Hori	9748.000	AV	32.3	37.2	10.9	33.3	-	47.1	53.9	6.8	Floor noise
Vert	1050.000	PK	52.3	23.7	5.7	35.2	-	46.5	73.9	27.4	
Vert	1150.000	PK	55.4	24.1	5.8	34.9	-	50.4	73.9	23.5	
Vert	1250.000	PK	51.2	24.4	5.9	34.6	-	46.9	73.9	27.0	
Vert	4874.000	PK	40.6	31.2	9.0	31.7	-	49.1	73.9	24.8	Floor noise
Vert	7311.000	PK	41.6	35.6	10.3	32.6	-	54.9	73.9	19.0	Floor noise
Vert	9748.000	PK	41.0	37.2	10.9	33.3	-	55.8	73.9	18.1	Floor noise
Vert	1050.000	AV	50.9	23.7	5.7	35.2	-	45.1	53.9	8.8	
Vert	1150.000	AV	54.5	24.1	5.8	34.9	-	49.5	53.9	4.4	
Vert	1250.000	AV	49.8	24.4	5.9	34.6	-	45.5	53.9	8.4	
Vert	4874.000	AV	31.4	31.2	9.0	31.7	-	39.9	53.9	14.0	Floor noise
Vert	7311.000	AV	32.9	35.6	10.3	32.6	-	46.2	53.9	7.7	Floor noise
Vert	9748.000	AV	32.4	37.2	10.9	33.3	-	47.2	53.9	6.7	Floor noise

Result = Reading + Ant Factor + Loss (Cable+Attenuator+Filter+Distance factor(above 1 GHz)) - Gain(Amplifier)

\*Other frequency noises omitted in this report were not seen or had enough margin (more than 20 dB).

Distance factor:     1 GHz - 10 GHz    20log (4.45 m / 3.0 m) = 3.43 dB  
                          10 GHz - 26.5 GHz 20log (1.0 m / 3.0 m) = -9.5 dB



**Radiated Spurious Emission**  
**(Reference Plot for band-edge)**

Test place	Ise EMC Lab. No.1 Semi Anechoic Chamber
Report No.	11500829H
Date	December 20, 2016
Temperature / Humidity	25 deg. C / 37 % RH
Engineer	Takumi Shimada (1 GHz -10 GHz)
Mode	Tx 11g 2462 MHz

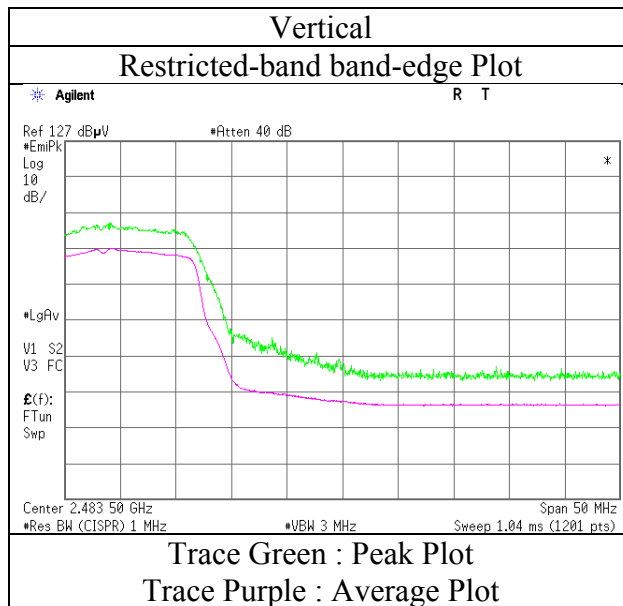
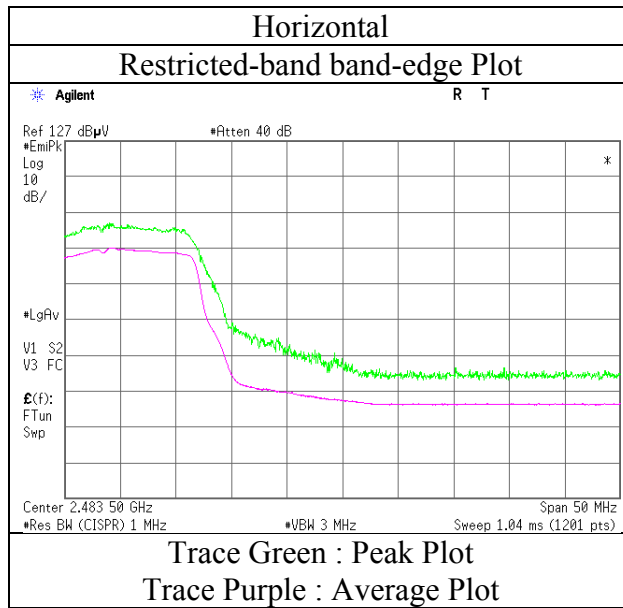

\* Final result of restricted band edge was shown in tabular data.

## Radiated Spurious Emission

Test place : Ise EMC Lab. No.3 Semi Anechoic Chamber  
Report No. : 11500829H  
Date : December 20, 2016  
Temperature / Humidity : 25 deg. C / 37 % RH  
Engineer : Takumi Shimada  
(Band Edge)  
Mode : Tx 11n-20 2412 MHz

Polarity	Frequency [MHz]	Detector	Reading [dBuV]	Ant.Fac. [dB/m]	Loss [dB]	Gain [dB]	Duty Factor [dB]	Result [dBuV/m]	Limit [dBuV/m]	Margin [dB]	Remark
Hori	2390.000	PK	64.6	26.7	6.8	32.7	-	65.4	73.9	8.5	
Hori	2390.000	AV	48.0	26.7	6.8	32.7	0.4	49.2	53.9	4.7	*1)
Vert	2390.000	PK	62.4	26.7	6.8	32.7	-	63.2	73.9	10.7	
Vert	2390.000	AV	46.5	26.7	6.8	32.7	0.4	47.7	53.9	6.2	*1)

Result = Reading + Ant Factor + Loss (Cable+Attenuator+Filter+Distance factor(above 1 GHz)) - Gain(Amplifier) + Duty factor  
\*Other frequency noises omitted in this report were not seen or had enough margin (more than 20 dB).

Distance factor: 1 GHz - 10 GHz  $20\log(4.45\text{ m} / 3.0\text{ m}) = 3.43\text{ dB}$   
10 GHz - 26.5 GHz  $20\log(1.0\text{ m} / 3.0\text{ m}) = -9.5\text{ dB}$

\*1) Not Out of Band emission(Leakage Power)

### 20dBc Data Sheet

Polarity	Frequency [MHz]	Detector	Reading [dBuV]	Ant Factor [dB/m]	Loss [dB]	Gain [dB]	Result [dBuV/m]	Limit [dBuV/m]	Margin [dB]	Remark
Hori	2412.000	PK	97.3	26.7	6.8	32.7	98.1	-	-	Carrier
Hori	2400.000	PK	62.7	26.7	6.8	32.7	63.5	78.1	14.6	
Vert	2412.000	PK	97.4	26.7	6.8	32.7	98.2	-	-	Carrier
Vert	2400.000	PK	61.3	26.7	6.8	32.7	62.1	78.2	16.1	

Result = Reading + Ant Factor + Loss (Cable+Attenuator+Filter+Distance factor(above 1 GHz)) - Gain(Amplifier)

**Radiated Spurious Emission**  
**(Reference Plot for band-edge)**

Test place	Ise EMC Lab. No.3 Semi Anechoic Chamber
Report No.	11500829H
Date	December 20, 2016
Temperature / Humidity	25 deg. C / 37 % RH
Engineer	Takumi Shimada (Band Edge)
Mode	Tx 11n-20 2412 MHz

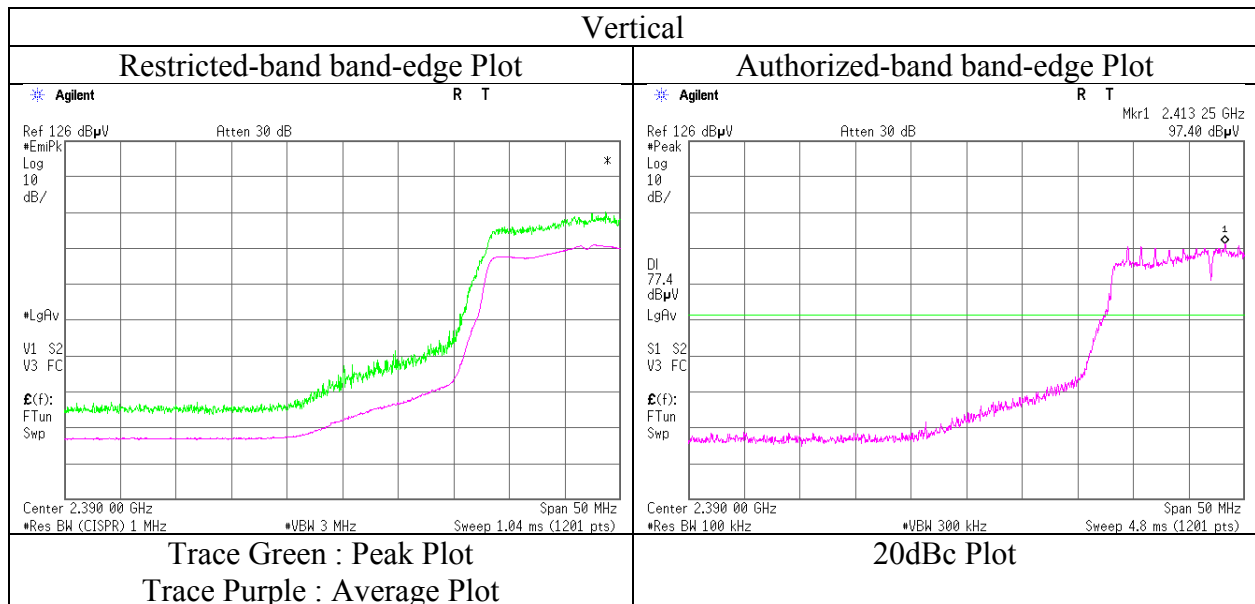
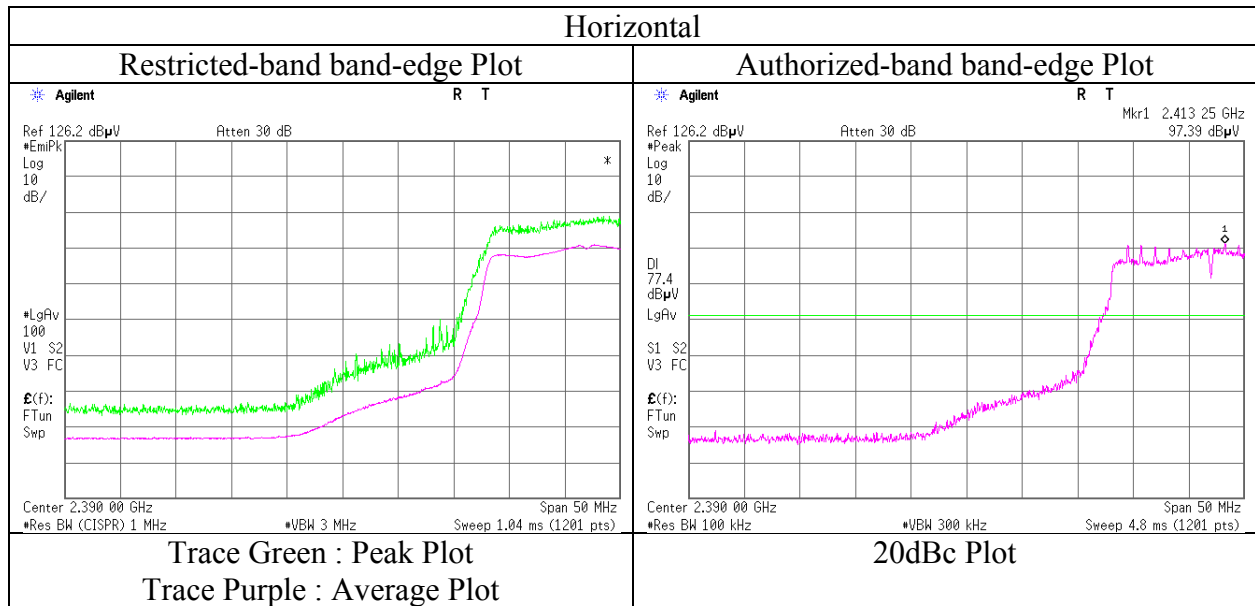

\* Final result of restricted band edge was shown in tabular data.

## Radiated Spurious Emission

Test place : Ise EMC Lab. No.3 Semi Anechoic Chamber  
Report No. : 11500829H  
Date : December 20, 2016  
Temperature / Humidity : 25 deg. C / 37 % RH  
Engineer : Takumi Shimada  
(Band Edge)  
Mode : Tx 11n-20 2462 MHz

Polarity	Frequency [MHz]	Detector	Reading [dBuV]	Ant.Fac. [dB/m]	Loss [dB]	Gain [dB]	Duty Factor [dB]	Result [dBuV/m]	Limit [dBuV/m]	Margin [dB]	Remark
Hori	2483.500	PK	68.2	26.8	6.9	32.6	-	69.3	73.9	4.6	
Hori	2483.500	AV	43.6	26.8	6.9	32.6	0.4	45.1	53.9	8.8	*1)
Vert	2483.500	PK	69.1	26.8	6.9	32.6	-	70.2	73.9	3.7	
Vert	2483.500	AV	49.6	26.8	6.9	32.6	0.4	51.1	53.9	2.8	*1)

Result = Reading + Ant Factor + Loss (Cable+Attenuator+Filter+Distance factor(above 1 GHz)) - Gain(Amplifier) + Duty factor

\*Other frequency noises omitted in this report were not seen or had enough margin (more than 20 dB).

Distance factor: 1 GHz - 10 GHz  $20\log(4.45\text{ m} / 3.0\text{ m}) = 3.43\text{ dB}$   
10 GHz - 26.5 GHz  $20\log(1.0\text{ m} / 3.0\text{ m}) = -9.5\text{ dB}$

\*1) Not Out of Band emission(Leakage Power)

**Radiated Spurious Emission**  
**(Reference Plot for band-edge)**

Test place : Ise EMC Lab. No.1 Semi Anechoic Chamber  
Report No. : 11500829H  
Date : December 20, 2016  
Temperature / Humidity : 25 deg. C / 37 % RH  
Engineer : Takumi Shimada  
(Band Edge)  
Mode : Tx 11n-20 2462 MHz

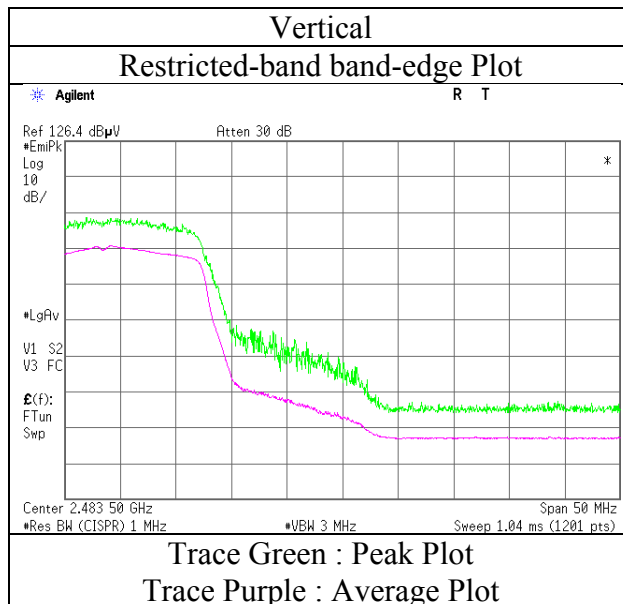
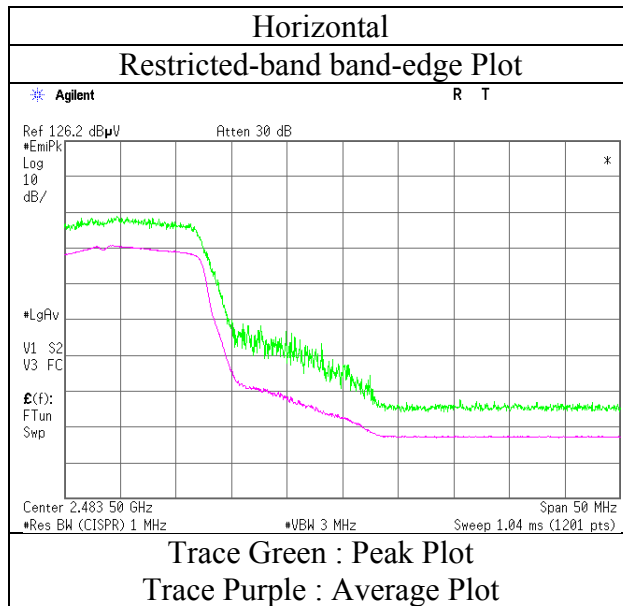

\* Final result of restricted band edge was shown in tabular data.

## Radiated Spurious Emission

Test place : Ise EMC Lab. No.3 Semi Anechoic Chamber  
Report No. : 11500829H  
Date : December 19, 2016      December 21, 2016      December 21, 2016      December 22, 2016  
Temperature / Humidity : 24 deg. C / 33 % RH      21 deg. C / 34 % RH      25deg. C / 33 % RH      23deg. C / 45 % RH  
Engineer : Tomoki Matsui      Ken Fujita      Tomoki Matsui      Tomoki Matsui  
            (1 GHz -10 GHz)      (10 GHz - 18 GHz)      (18 GHz - 26.5 GHz)      (Below 1 GHz)  
Mode : Tx BT LE 2402 MHz

Polarity	Frequency [MHz]	Detector	Reading [dBuV]	Ant.Fac. [dB/m]	Loss [dB]	Gain [dB]	Duty Factor [dB]	Result [dBuV/m]	Limit [dBuV/m]	Margin [dB]	Remark
Hori	52.740	QP	39.6	9.8	7.5	32.2	-	24.7	40.0	15.3	
Hori	126.000	QP	42.0	13.4	8.5	32.1	-	31.8	43.5	11.7	
Hori	168.000	QP	46.0	15.9	8.9	32.1	-	38.7	43.5	4.8	
Hori	180.000	QP	38.0	16.3	9.0	32.1	-	31.2	43.5	12.3	
Hori	192.000	QP	43.8	16.4	9.1	32.1	-	37.2	43.5	6.3	
Hori	196.600	QP	38.7	16.4	9.2	32.1	-	32.2	43.5	11.3	
Hori	1050.000	PK	55.5	23.7	5.7	35.2	-	49.7	73.9	24.2	
Hori	1150.000	PK	56.5	24.1	5.8	34.9	-	51.5	73.9	22.4	
Hori	1250.000	PK	54.5	24.4	5.9	34.6	-	50.2	73.9	23.7	
Hori	2390.000	PK	42.9	26.7	6.8	32.7	-	43.7	73.9	30.2	
Hori	4804.000	PK	38.6	31.0	9.0	31.8	-	46.8	73.9	27.1	Floor noise
Hori	7206.000	PK	39.2	35.7	10.3	32.6	-	52.6	73.9	21.3	Floor noise
Hori	9608.000	PK	40.2	37.2	10.9	33.2	-	55.1	73.9	18.8	Floor noise
Hori	1050.000	AV	53.3	23.7	5.7	35.2	-	47.5	53.9	6.4	
Hori	1150.000	AV	54.9	24.1	5.8	34.9	-	49.9	53.9	4.0	
Hori	1250.000	AV	52.7	24.4	5.9	34.6	-	48.4	53.9	5.5	
Hori	2390.000	AV	33.1	26.7	6.8	32.7	3.6	37.5	53.9	16.4	*1)
Hori	4804.000	AV	30.1	31.0	9.0	31.8	-	38.3	53.9	15.6	Floor noise
Hori	7206.000	AV	30.7	35.7	10.3	32.6	-	44.1	53.9	9.8	Floor noise
Hori	9608.000	AV	31.5	37.2	10.9	33.2	-	46.4	53.9	7.5	Floor noise
Vert	39.350	QP	44.1	14.5	7.3	32.2	-	33.7	40.0	6.3	
Vert	45.020	QP	44.2	12.6	7.4	32.2	-	32.0	40.0	8.0	
Vert	48.002	QP	46.4	11.5	7.4	32.2	-	33.1	40.0	6.9	
Vert	158.000	QP	34.0	15.5	8.8	32.1	-	26.2	43.5	17.3	
Vert	168.000	QP	43.4	15.9	8.9	32.1	-	36.1	43.5	7.4	
Vert	196.600	QP	36.8	16.4	9.2	32.1	-	30.3	43.5	13.2	
Vert	1050.000	PK	56.5	23.7	5.7	35.2	-	50.7	73.9	23.2	
Vert	1150.000	PK	58.5	24.1	5.8	34.9	-	53.5	73.9	20.4	
Vert	1250.000	PK	53.4	24.4	5.9	34.6	-	49.1	73.9	24.8	
Vert	2390.000	PK	41.3	26.7	6.8	32.7	-	42.1	73.9	31.8	
Vert	4804.000	PK	38.6	31.0	9.0	31.8	-	46.8	73.9	27.1	Floor noise
Vert	7206.000	PK	39.2	35.7	10.3	32.6	-	52.6	73.9	21.3	Floor noise
Vert	9608.000	PK	40.2	37.2	10.9	33.2	-	55.1	73.9	18.8	Floor noise
Vert	1050.000	AV	54.4	23.7	5.7	35.2	-	48.6	53.9	5.3	
Vert	1150.000	AV	57.2	24.1	5.8	34.9	-	52.2	53.9	1.7	
Vert	1250.000	AV	51.1	24.4	5.9	34.6	-	46.8	53.9	7.1	
Vert	2390.000	AV	33.0	26.7	6.8	32.7	3.6	37.4	53.9	16.5	*1)
Vert	4804.000	AV	30.1	31.0	9.0	31.8	-	38.3	53.9	15.6	Floor noise
Vert	7206.000	AV	30.7	35.7	10.3	32.6	-	44.1	53.9	9.8	Floor noise
Vert	9608.000	AV	31.5	37.2	10.9	33.2	-	46.4	53.9	7.5	Floor noise

Result = Reading + Ant Factor + Loss (Cable+Attenuator+Filter+Distance factor(above 1 GHz)) - Gain(Amplifier) + Duty factor

\*Other frequency noises omitted in this report were not seen or had enough margin (more than 20 dB).

Distance factor: 1 GHz - 10 GHz 20log (4.45 m / 3.0 m) = 3.43 dB

10 GHz - 26.5 GHz 20log (1.0 m / 3.0 m) = -9.5 dB

\*1) Not Out of Band emission(Leakage Power)

### 20dBc Data Sheet

Polarity	Frequency [MHz]	Detector	Reading [dBuV]	Ant Factor [dB/m]	Loss [dB]	Gain [dB]	Result [dBuV/m]	Limit [dBuV/m]	Margin [dB]	Remark
Hori	2402.000	PK	98.7	26.7	6.8	32.7	99.5	-	-	Carrier
Hori	2400.000	PK	42.0	26.7	6.8	32.7	42.8	79.5	36.7	
Vert	2402.000	PK	99.1	26.7	6.8	32.7	99.9	-	-	Carrier
Vert	2400.000	PK	41.4	26.7	6.8	32.7	42.2	79.9	37.7	

Result = Reading + Ant Factor + Loss (Cable+Attenuator+Filter+Distance factor(above 1 GHz)) - Gain(Amplifier)

**UL Japan, Inc.**

**Ise EMC Lab.**

4383-326 Asama-cho, Ise-shi, Mie-ken 516-0021 JAPAN

Telephone : +81 596 24 8999

Facsimile : +81 596 24 8124

## Radiated Spurious Emission (Reference Plot for band-edge)

Test place	Ise EMC Lab. No.3 Semi Anechoic Chamber
Report No.	11500829H
Date	December 19, 2016
Temperature / Humidity	24 deg. C / 33 % RH
Engineer	Tomoki Matsui
	(1 GHz -10 GHz)
Mode	Tx BT LE 2402 MHz

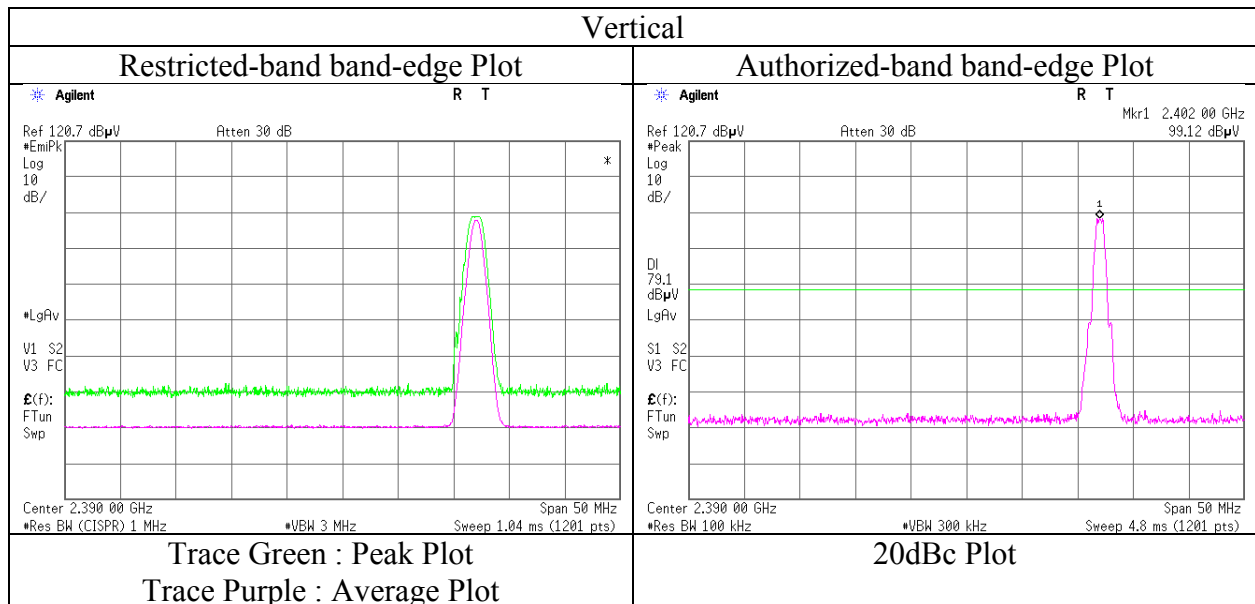
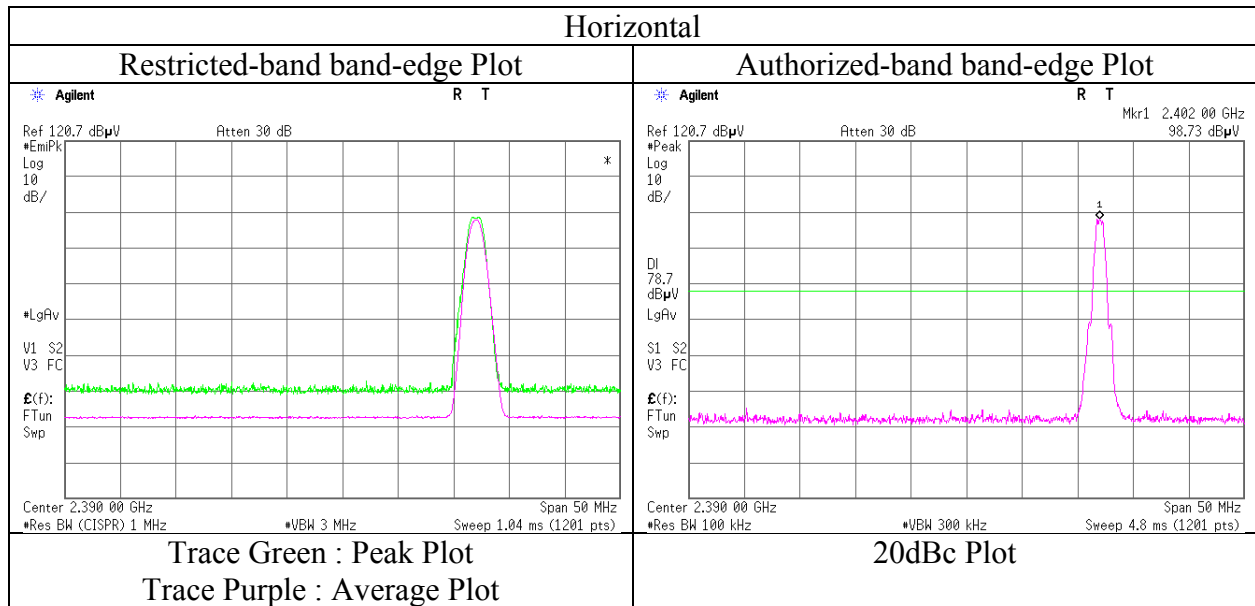

\* Final result of restricted band edge was shown in tabular data.

**UL Japan, Inc.**

**Ise EMC Lab.**

4383-326 Asama-cho, Ise-shi, Mie-ken 516-0021 JAPAN

Telephone : +81 596 24 8999

Facsimile : +81 596 24 8124

## Radiated Spurious Emission

Test place : Ise EMC Lab. No.3 Semi Anechoic Chamber  
Report No. : 11500829H  
Date : December 19, 2016      December 21, 2016      December 21, 2016      December 22, 2016  
Temperature / Humidity : 24 deg. C / 33 % RH      21 deg. C / 34 % RH      25deg. C / 33 % RH      23deg. C / 45 % RH  
Engineer : Tomoki Matsui      Ken Fujita      Tomoki Matsui      Tomoki Matsui  
            (1 GHz - 10 GHz)      (10 GHz - 18 GHz)      (18 GHz - 26.5 GHz)      (Below 1 GHz)  
Mode : Tx BT LE 2440 MHz

Polarity	Frequency [MHz]	Detector	Reading [dBuV]	Ant.Fac. [dB/m]	Loss [dB]	Gain [dB]	Duty Factor [dB]	Result [dBuV/m]	Limit [dBuV/m]	Margin [dB]	Remark
Hori	52.740	QP	39.6	9.8	7.5	32.2	-	24.7	40.0	15.3	
Hori	126.000	QP	42.0	13.4	8.5	32.1	-	31.8	43.5	11.7	
Hori	168.000	QP	46.0	15.9	8.9	32.1	-	38.7	43.5	4.8	
Hori	180.000	QP	38.0	16.3	9.0	32.1	-	31.2	43.5	12.3	
Hori	192.000	QP	43.2	16.4	9.1	32.1	-	36.6	43.5	6.9	
Hori	196.600	QP	38.6	16.4	9.2	32.1	-	32.1	43.5	11.4	
Hori	1050.000	PK	55.9	23.7	5.7	35.2	-	50.1	73.9	23.8	
Hori	1150.000	PK	58.0	24.1	5.8	34.9	-	53.0	73.9	20.9	
Hori	1250.000	PK	54.1	24.4	5.9	34.6	-	49.8	73.9	24.1	
Hori	4880.000	PK	38.4	31.3	9.0	31.7	-	47.0	73.9	26.9	Floor noise
Hori	7320.000	PK	40.5	35.6	10.2	32.6	-	53.7	73.9	20.2	Floor noise
Hori	9760.000	PK	39.2	37.2	10.9	33.3	-	54.0	73.9	19.9	Floor noise
Hori	1050.000	AV	53.6	23.7	5.7	35.2	-	47.8	53.9	6.1	
Hori	1150.000	AV	56.8	24.1	5.8	34.9	-	51.8	53.9	2.1	
Hori	1250.000	AV	51.9	24.4	5.9	34.6	-	47.6	53.9	6.3	
Hori	4880.000	AV	29.8	31.3	9.0	31.7	-	38.4	53.9	15.5	Floor noise
Hori	7320.000	AV	30.9	35.6	10.2	32.6	-	44.1	53.9	9.8	Floor noise
Hori	9760.000	AV	30.7	37.2	10.9	33.3	-	45.5	53.9	8.4	Floor noise
Vert	39.350	QP	44.2	14.5	7.3	32.2	-	33.8	40.0	6.2	
Vert	45.020	QP	44.3	12.6	7.4	32.2	-	32.1	40.0	7.9	
Vert	48.002	QP	46.4	11.5	7.4	32.2	-	33.1	40.0	6.9	
Vert	158.000	QP	34.0	15.5	8.8	32.1	-	26.2	43.5	17.3	
Vert	168.000	QP	43.0	15.9	8.9	32.1	-	35.7	43.5	7.8	
Vert	196.600	QP	36.4	16.4	9.2	32.1	-	29.9	43.5	13.6	
Vert	1050.000	PK	55.4	23.7	5.7	35.2	-	49.6	73.9	24.3	
Vert	1150.000	PK	56.6	24.1	5.8	34.9	-	51.6	73.9	22.3	
Vert	1250.000	PK	51.4	24.4	5.9	34.6	-	47.1	73.9	26.8	
Vert	4880.000	PK	38.4	31.3	9.0	31.7	-	47.0	73.9	26.9	Floor noise
Vert	7320.000	PK	40.5	35.6	10.2	32.6	-	53.7	73.9	20.2	Floor noise
Vert	9760.000	PK	39.2	37.2	10.9	33.3	-	54.0	73.9	19.9	Floor noise
Vert	1050.000	AV	52.9	23.7	5.7	35.2	-	47.1	53.9	6.8	
Vert	1150.000	AV	54.9	24.1	5.8	34.9	-	49.9	53.9	4.0	
Vert	1250.000	AV	48.7	24.4	5.9	34.6	-	44.4	53.9	9.5	
Vert	4880.000	AV	29.8	31.3	9.0	31.7	-	38.4	53.9	15.5	Floor noise
Vert	7320.000	AV	30.9	35.6	10.2	32.6	-	44.1	53.9	9.8	Floor noise
Vert	9760.000	AV	30.7	37.2	10.9	33.3	-	45.5	53.9	8.4	Floor noise

Result = Reading + Ant Factor + Loss (Cable+Attenuator+Filter+Distance factor(above 1 GHz)) - Gain(Amplifier)

\*Other frequency noises omitted in this report were not seen or had enough margin (more than 20 dB).

Distance factor:      1 GHz - 10 GHz      20log (4.45 m / 3.0 m) = 3.43 dB  
                                 10 GHz - 26.5 GHz 20log (1.0 m / 3.0 m) = -9.5 dB

## Radiated Spurious Emission

Test place : Ise EMC Lab. No.3 Semi Anechoic Chamber  
Report No. : 11500829H  
Date : December 19, 2016      December 21, 2016      December 21, 2016      December 22, 2016  
Temperature / Humidity : 24 deg. C / 33 % RH      21 deg. C / 34 % RH      25deg. C / 33 % RH      23deg. C / 45 % RH  
Engineer : Tomoki Matsui      Ken Fujita      Tomoki Matsui      Tomoki Matsui  
            (1 GHz -10 GHz)      (10 GHz - 18 GHz)      (18 GHz - 26.5 GHz)      (Below 1 GHz)  
Mode : Tx BT LE 2480 MHz

Polarity	Frequency [MHz]	Detector	Reading [dBuV]	Ant.Fac. [dB/m]	Loss [dB]	Gain [dB]	Duty Factor [dB]	Result [dBuV/m]	Limit [dBuV/m]	Margin [dB]	Remark
Hori	52.740	QP	39.6	9.8	7.5	32.2	-	24.7	40.0	15.3	
Hori	126.000	QP	42.1	13.4	8.5	32.1	-	31.9	43.5	11.6	
Hori	168.000	QP	45.8	15.9	8.9	32.1	-	38.5	43.5	5.0	
Hori	180.000	QP	38.0	16.3	9.0	32.1	-	31.2	43.5	12.3	
Hori	192.000	QP	43.4	16.4	9.1	32.1	-	36.8	43.5	6.7	
Hori	196.600	QP	38.7	16.4	9.2	32.1	-	32.2	43.5	11.3	
Hori	1050.000	PK	55.4	23.7	5.7	35.2	-	49.6	73.9	24.3	
Hori	1150.000	PK	57.9	24.1	5.8	34.9	-	52.9	73.9	21.0	
Hori	1250.000	PK	54.1	24.4	5.9	34.6	-	49.8	73.9	24.1	
Hori	2483.500	PK	46.0	26.8	6.9	32.6	-	47.1	73.9	26.8	
Hori	4960.000	PK	39.2	31.5	9.0	31.7	-	48.0	73.9	25.9	Floor noise
Hori	7440.000	PK	38.6	35.5	10.3	32.7	-	51.7	73.9	22.2	Floor noise
Hori	9920.000	PK	39.8	37.2	11.0	33.4	-	54.6	73.9	19.3	Floor noise
Hori	1050.000	AV	53.2	23.7	5.7	35.2	-	47.4	53.9	6.5	
Hori	1150.000	AV	56.5	24.1	5.8	34.9	-	51.5	53.9	2.4	
Hori	1250.000	AV	52.0	24.4	5.9	34.6	-	47.7	53.9	6.2	
Hori	2483.500	AV	34.1	26.8	6.9	32.6	3.6	38.8	53.9	15.1	*1)
Hori	4960.000	AV	30.3	31.5	9.0	31.7	-	39.1	53.9	14.8	Floor noise
Hori	7440.000	AV	30.2	35.5	10.3	32.7	-	43.3	53.9	10.6	Floor noise
Hori	9920.000	AV	31.0	37.2	11.0	33.4	-	45.8	53.9	8.1	Floor noise
Vert	39.350	QP	44.1	14.5	7.3	32.2	-	33.7	40.0	6.3	
Vert	45.020	QP	44.3	12.6	7.4	32.2	-	32.1	40.0	7.9	
Vert	48.002	QP	46.1	11.5	7.4	32.2	-	32.8	40.0	7.2	
Vert	158.000	QP	34.0	15.5	8.8	32.1	-	26.2	43.5	17.3	
Vert	168.000	QP	43.0	15.9	8.9	32.1	-	35.7	43.5	7.8	
Vert	196.600	QP	36.4	16.4	9.2	32.1	-	29.9	43.5	13.6	
Vert	1050.000	PK	55.7	23.7	5.7	35.2	-	49.9	73.9	24.0	
Vert	1150.000	PK	56.7	24.1	5.8	34.9	-	51.7	73.9	22.2	
Vert	1250.000	PK	52.6	24.4	5.9	34.6	-	48.3	73.9	25.6	
Vert	2483.500	PK	43.9	26.8	6.9	32.6	-	45.0	73.9	28.9	
Vert	4960.000	PK	39.2	31.5	9.0	31.7	-	48.0	73.9	25.9	Floor noise
Vert	7440.000	PK	38.6	35.5	10.3	32.7	-	51.7	73.9	22.2	Floor noise
Vert	9920.000	PK	39.8	37.2	11.0	33.4	-	54.6	73.9	19.3	Floor noise
Vert	1050.000	AV	53.1	23.7	5.7	35.2	-	47.3	53.9	6.6	
Vert	1150.000	AV	55.2	24.1	5.8	34.9	-	50.2	53.9	3.7	
Vert	1250.000	AV	49.7	24.4	5.9	34.6	-	45.4	53.9	8.5	
Vert	2483.500	AV	33.5	26.8	6.9	32.6	3.6	38.2	53.9	15.7	*1)
Vert	4960.000	AV	30.3	31.5	9.0	31.7	-	39.1	53.9	14.8	Floor noise
Vert	7440.000	AV	30.2	35.5	10.3	32.7	-	43.3	53.9	10.6	Floor noise
Vert	9920.000	AV	31.0	37.2	11.0	33.4	-	45.8	53.9	8.1	Floor noise

Result = Reading + Ant Factor + Loss (Cable+Attenuator+Filter+Distance factor(above 1 GHz)) - Gain(Amplifier) + Duty factor

\*Other frequency noises omitted in this report were not seen or had enough margin (more than 20 dB).

Distance factor: 1 GHz - 10 GHz  $20\log(4.45\text{ m} / 3.0\text{ m}) = 3.43\text{ dB}$

10 GHz - 26.5 GHz  $20\log(1.0\text{ m} / 3.0\text{ m}) = -9.5\text{ dB}$

\*1) Not Out of Band emission(Leakage Power)

**Radiated Spurious Emission**  
**(Reference Plot for band-edge)**

Test place	Ise EMC Lab. No.3 Semi Anechoic Chamber
Report No.	11500829H
Date	December 19, 2016
Temperature / Humidity	24 deg. C / 33 % RH
Engineer	Tomoki Matsui
	(1 GHz -10 GHz)
Mode	Tx BT LE 2480 MHz

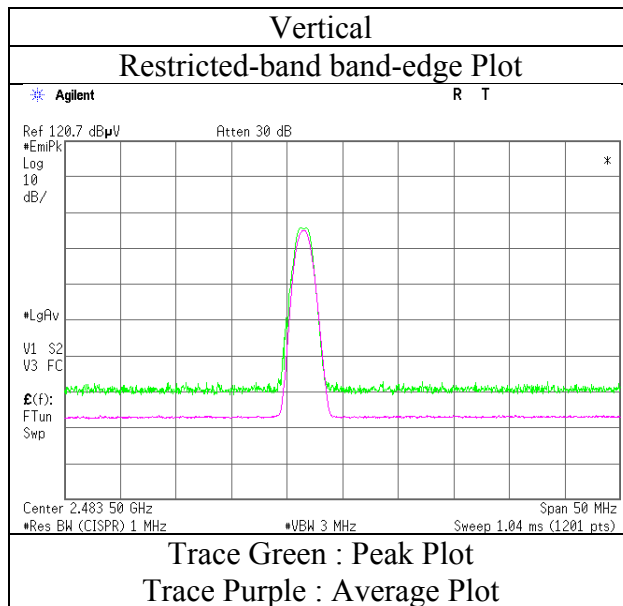
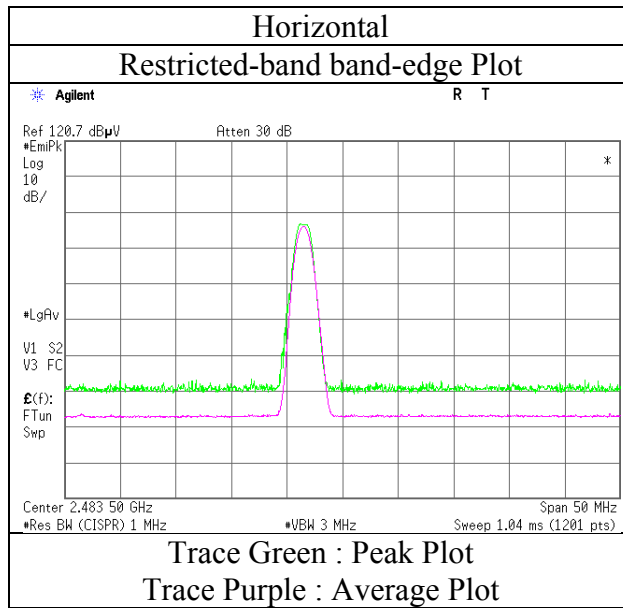

\* Final result of restricted band edge was shown in tabular data.

**Radiated Spurious Emission**  
**(Plot data, Worst case)**

Test place	Ise EMC Lab. No.3 Semi Anechoic Chamber			
Report No.	11500829H			
Date	December 20, 2016	December 21, 2016	December 21, 2016	December 22, 2016
Temperature / Humidity	25 deg. C / 37 % RH	21 deg. C / 34 % RH	25deg. C / 33 % RH	23deg. C / 45 % RH
Engineer	Takumi Shimada (1 GHz -10 GHz)	Ken Fujita (10 GHz - 18 GHz)	Tomoki Matsui (18 GHz - 26.5 GHz)	Tomoki Matsui (Below 1 GHz)
Mode	Tx 11g 2462 MHz			

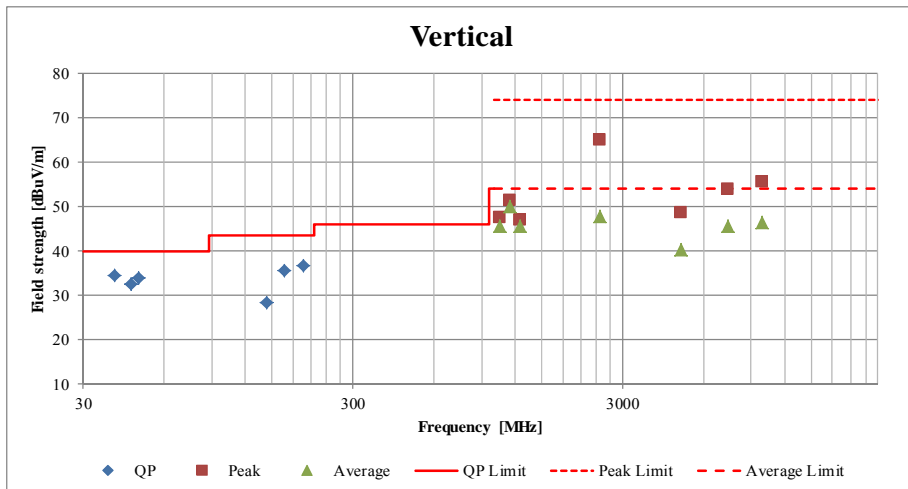
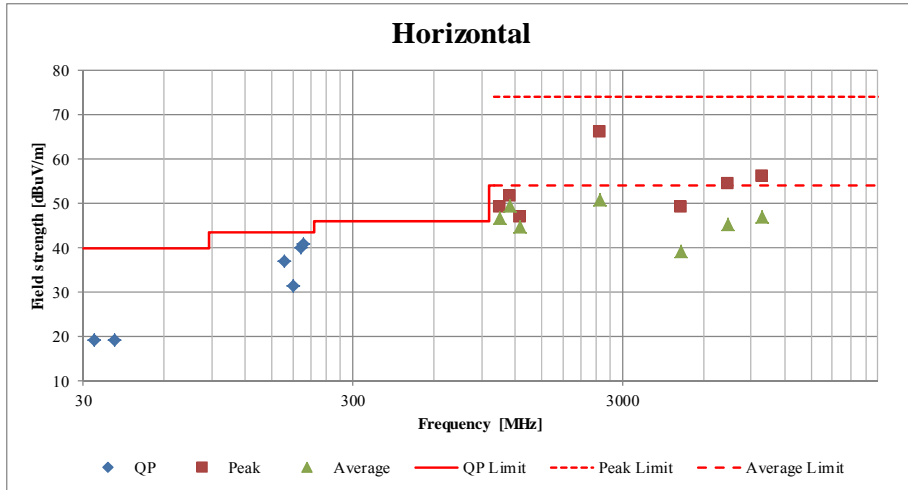

\*These plots data contains sufficient number to show the trend of characteristic features for EUT.

## Radiated Spurious Emission (Plot data, Worst case)

Test place	Ise EMC Lab. No.3 Semi Anechoic Chamber			
Report No.	11500829H			
Date	December 19, 2016	December 21, 2016	December 21, 2016	December 22, 2016
Temperature / Humidity	24 deg. C / 33 % RH	21 deg. C / 34 % RH	25deg. C / 33 % RH	23deg. C / 45 % RH
Engineer	Tomoki Matsui	Ken Fujita	Tomoki Matsui	Tomoki Matsui
	(1 GHz - 10 GHz)	(10 GHz - 18 GHz)	(18 GHz - 26.5 GHz)	(Below 1 GHz)
Mode	Tx BT LE 2440 MHz			

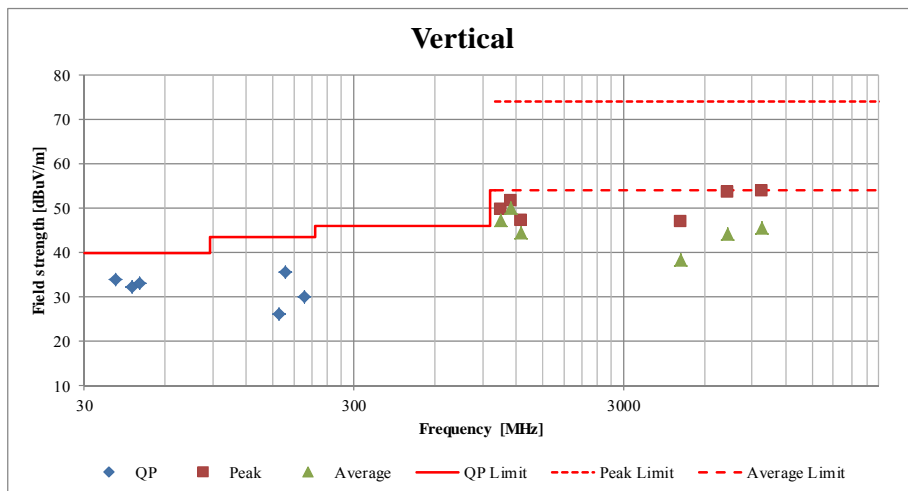
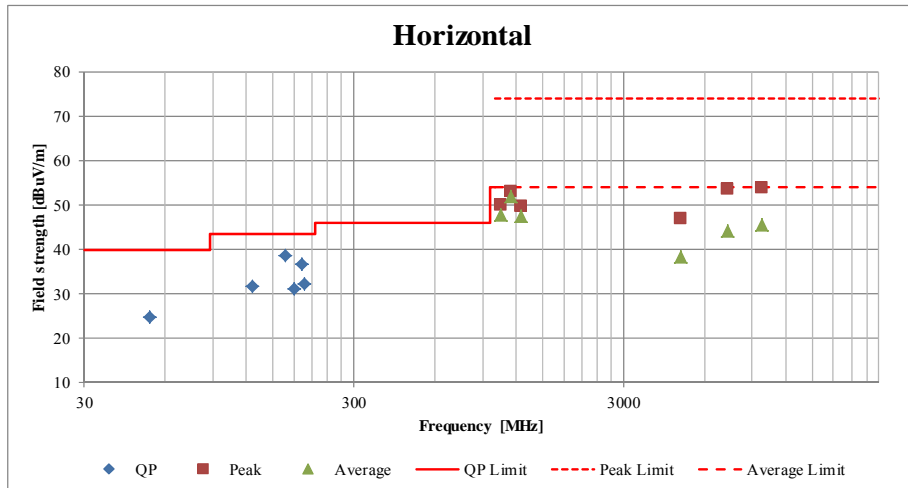

\*These plots data contains sufficient number to show the trend of characteristic features for EUT.

## Conducted Spurious Emission

Test place	Ise EMC Lab. No.6 Measurement Room
Report No.	11500829H
Date	December 13, 2016
Temperature / Humidity	24 deg. C / 31 % RH
Engineer	Yutaka Yoshida
Mode	Tx 11g 2462 MHz

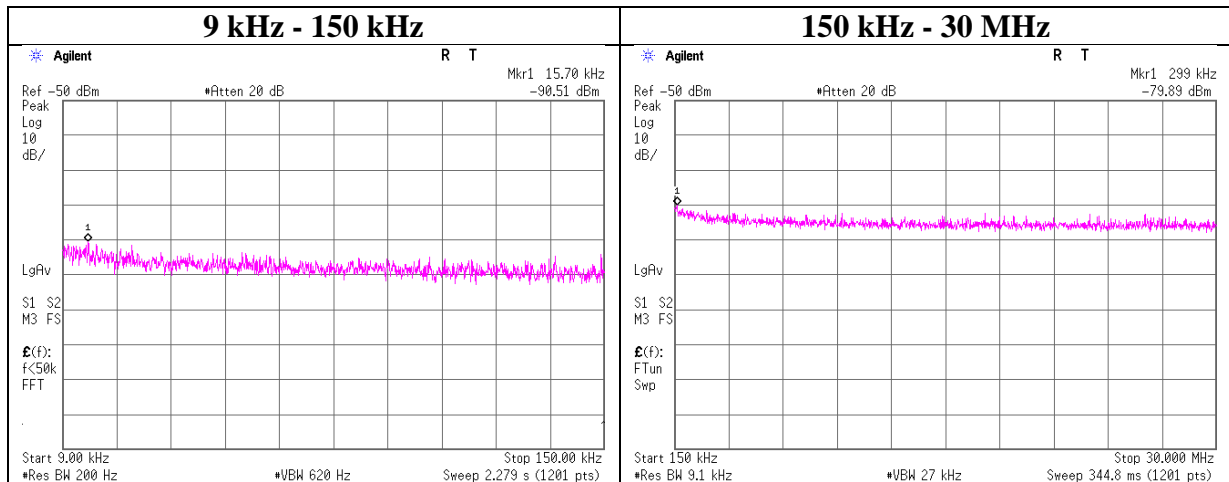

Frequency [kHz]	Reading [dBm]	Cable Loss [dB]	Attenuator Loss [dB]	Antenna Gain* [dBi]	N (Number of Output)	EIRP [dBm]	Distance [m]	Ground bounce [dB]	E (field strength) [dBuV/m]	Limit [dBuV/m]	Margin [dB]	Remark
15.70	-90.5	0.51	9.8	2.0	1	-78.2	300	6.0	-16.9	43.6	60.5	
299.00	-79.9	0.51	9.8	2.0	1	-67.5	300	6.0	-6.3	18.0	24.3	

$$E \text{ [dBuV/m]} = \text{EIRP [dBm]} - 20 \log (\text{Distance [m]}) + \text{Ground bounce [dB]} + 104.8 \text{ [dBuV/m]}$$

$$\text{EIRP [dBm]} = \text{Reading [dBm]} + \text{Cable loss [dB]} + \text{Attenuator Loss [dB]} + \text{Antenna gain [dBi]} + 10 * \log (N)$$

N: Number of output

\*2.0 dBi was applied to the test result based on KDB 558074 since antenna gain was less than 2.0 dBi.

**UL Japan, Inc.**

**Ise EMC Lab.**

4383-326 Asama-cho, Ise-shi, Mie-ken 516-0021 JAPAN

Telephone : +81 596 24 8999

Facsimile : +81 596 24 8124

## Conducted Spurious Emission

Test place	Ise EMC Lab. No.6 Measurement Room
Report No.	11500829H
Date	December 13, 2016
Temperature / Humidity	24 deg. C / 31 % RH
Engineer	Yutaka Yoshida
Mode	Tx BT LE 2402 MHz

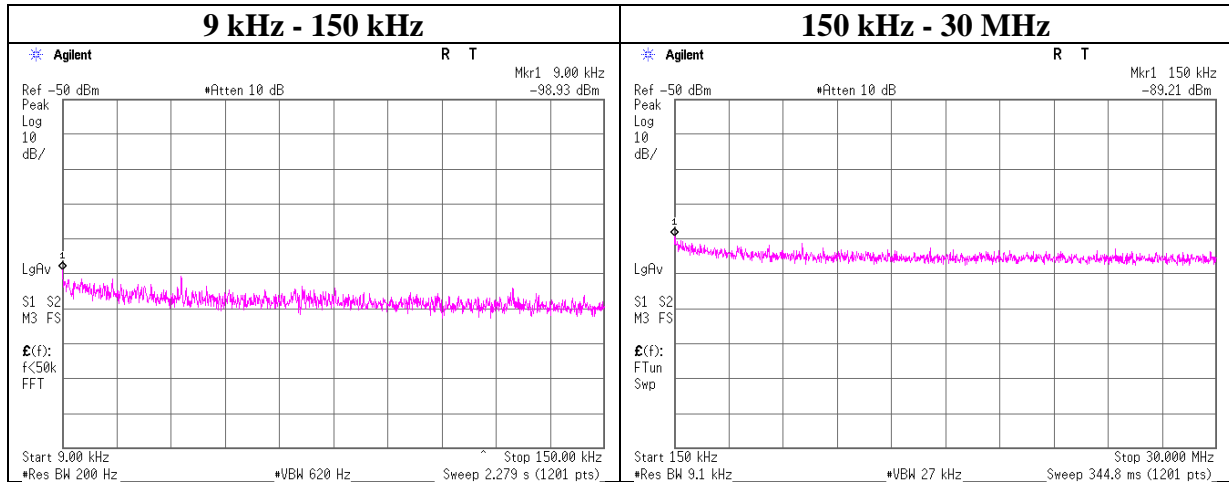

Frequency [kHz]	Reading [dBm]	Cable Loss [dB]	Attenuator Loss [dB]	Antenna Gain* [dBi]	N (Number of Output)	EIRP [dBm]	Distance [m]	Ground bounce [dB]	E (field strength) [dBuV/m]	Limit [dBuV/m]	Margin [dB]	Remark
9.00	-98.9	0.51	9.8	2.0	1	-86.6	300	6.0	-25.3	48.5	73.8	
150.00	-89.2	0.51	9.8	2.0	1	-76.9	300	6.0	-15.6	24.0	39.6	

$$E \text{ [dBuV/m]} = \text{EIRP [dBm]} - 20 \log (\text{Distance [m]}) + \text{Ground bounce [dB]} + 104.8 \text{ [dBuV/m]}$$

$$\text{EIRP [dBm]} = \text{Reading [dBm]} + \text{Cable loss [dB]} + \text{Attenuator Loss [dB]} + \text{Antenna gain [dBi]} + 10 * \log (N)$$

N: Number of output

\*2.0 dBi was applied to the test result based on KDB 558074 since antenna gain was less than 2.0 dBi.

**UL Japan, Inc.**

**Ise EMC Lab.**

4383-326 Asama-cho, Ise-shi, Mie-ken 516-0021 JAPAN

Telephone : +81 596 24 8999

Facsimile : +81 596 24 8124

## Conducted Spurious Emission

Test place	Ise EMC Lab. No.6 Measurement Room
Report No.	11500829H
Date	December 13, 2016
Temperature / Humidity	24 deg. C / 31 % RH
Engineer	Yutaka Yoshida
Mode	Tx BT LE 2440 MHz

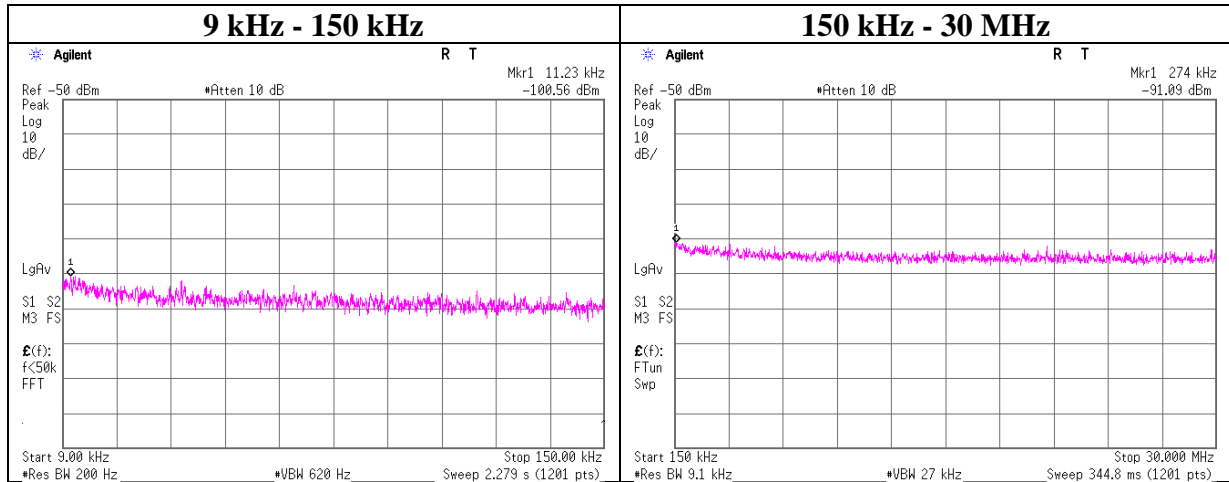

Frequency [kHz]	Reading [dBm]	Cable Loss [dB]	Attenuator Loss [dB]	Antenna Gain* [dBi]	N (Number of Output)	EIRP [dBm]	Distance [m]	Ground bounce [dB]	E (field strength) [dBuV/m]	Limit [dBuV/m]	Margin [dB]	Remark
11.23	-100.6	0.51	9.8	2.0	1	-88.2	300	6.0	-27.0	46.5	73.5	
274.00	-91.1	0.51	9.8	2.0	1	-78.7	300	6.0	-17.5	18.8	36.3	

$$E \text{ [dBuV/m]} = \text{EIRP [dBm]} - 20 \log (\text{Distance [m]}) + \text{Ground bounce [dB]} + 104.8 \text{ [dBuV/m]}$$

$$\text{EIRP [dBm]} = \text{Reading [dBm]} + \text{Cable loss [dB]} + \text{Attenuator Loss [dB]} + \text{Antenna gain [dBi]} + 10 * \log (N)$$

N: Number of output

\*2.0 dBi was applied to the test result based on KDB 558074 since antenna gain was less than 2.0 dBi.

## Conducted Spurious Emission

Test place	Ise EMC Lab. No.6 Measurement Room
Report No.	11500829H
Date	December 13, 2016
Temperature / Humidity	24 deg. C / 31 % RH
Engineer	Yutaka Yoshida
Mode	Tx BT LE 2480 MHz

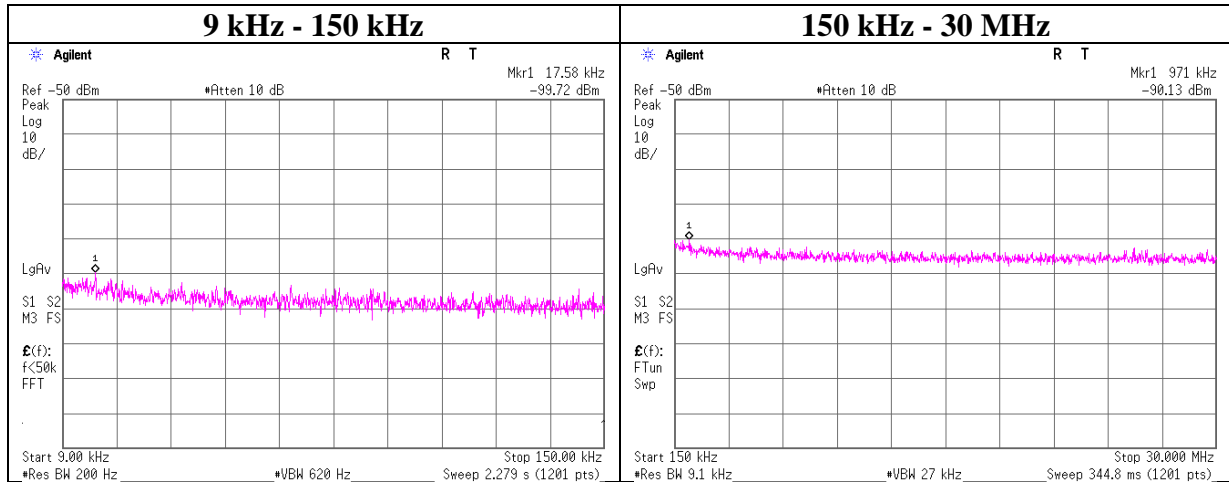

Frequency [kHz]	Reading [dBm]	Cable Loss [dB]	Attenuator Loss [dB]	Antenna Gain* [dBi]	N (Number of Output)	EIRP [dBm]	Distance [m]	Ground bounce [dB]	E (field strength) [dBuV/m]	Limit [dBuV/m]	Margin [dB]	Remark
17.58	-99.7	0.51	9.8	2.0	1	-87.4	300	6.0	-26.1	42.7	68.8	
971.00	-90.1	0.52	9.8	2.0	1	-77.8	30	6.0	3.5	27.8	24.3	

$E \text{ [dBuV/m]} = \text{EIRP [dBm]} - 20 \log(\text{Distance [m]}) + \text{Ground bounce [dB]} + 104.8 \text{ [dBuV/m]}$

$\text{EIRP [dBm]} = \text{Reading [dBm]} + \text{Cable loss [dB]} + \text{Attenuator Loss [dB]} + \text{Antenna gain [dBi]} + 10 * \log(N)$

N: Number of output

\*2.0 dBi was applied to the test result based on KDB 558074 since antenna gain was less than 2.0 dBi.

## Power Density

Test place Ise EMC Lab. No.6 Measurement Room  
Report No. 11500829H  
Date December 13, 2016  
Temperature / Humidity 24 deg. C / 31 % RH  
Engineer Yutaka Yoshida  
Mode Tx

### 11b 11Mbps

Freq. [MHz]	Reading [dBm]	Cable Loss [dB]	Atten. Loss [dB]	Result [dBm]	Limit [dBm]	Margin [dB]
2412.00	-16.95	1.51	10.06	-5.38	8.00	13.38
2437.00	-15.92	1.52	10.06	-4.34	8.00	12.34
2462.00	-15.26	1.52	10.06	-3.68	8.00	11.68

### 11g 6Mbps

Freq. [MHz]	Reading [dBm]	Cable Loss [dB]	Atten. Loss [dB]	Result [dBm]	Limit [dBm]	Margin [dB]
2412.00	-20.84	1.51	10.06	-9.27	8.00	17.27
2437.00	-19.73	1.52	10.06	-8.15	8.00	16.15
2462.00	-19.32	1.52	10.06	-7.74	8.00	15.74

### 11n-20 MCS0 Short GI

Freq. [MHz]	Reading [dBm]	Cable Loss [dB]	Atten. Loss [dB]	Result [dBm]	Limit [dBm]	Margin [dB]
2412.00	-21.45	1.51	10.06	-9.88	8.00	17.88
2437.00	-20.19	1.52	10.06	-8.61	8.00	16.61
2462.00	-19.61	1.52	10.06	-8.03	8.00	16.03

### BT LE

Freq. [MHz]	Reading [dBm]	Cable Loss [dB]	Atten. Loss [dB]	Result [dBm]	Limit [dBm]	Margin [dB]
2402.00	-21.16	1.51	10.06	-9.59	8.00	17.59
2440.00	-21.02	1.52	10.06	-9.44	8.00	17.44
2480.00	-22.66	1.53	10.06	-11.07	8.00	19.07

Sample Calculation:

Result = Reading + Cable Loss (including the cable(s) customer supplied) + Attenuator Loss

**Power Density**

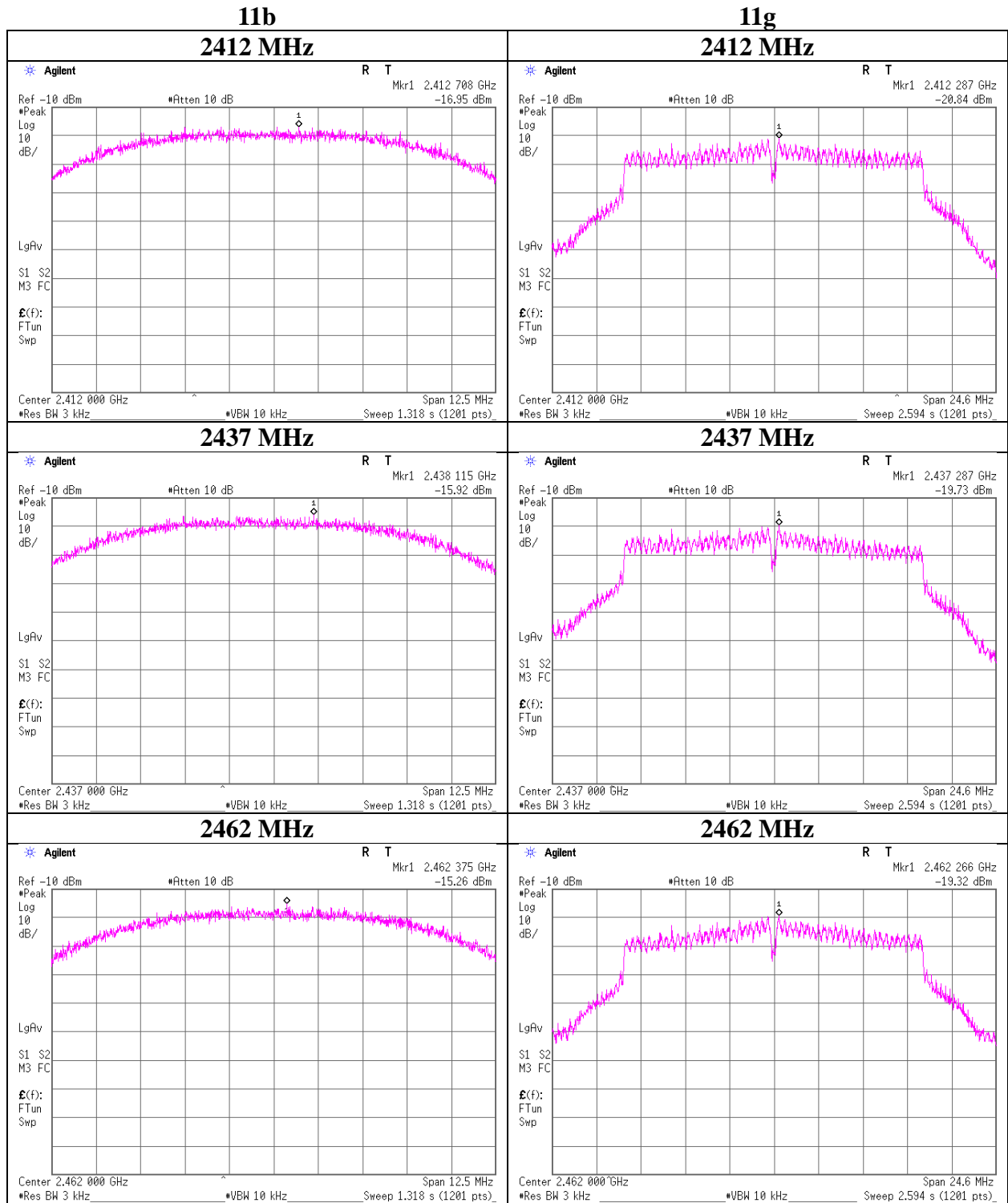

**UL Japan, Inc.**

**Ise EMC Lab.**

4383-326 Asama-cho, Ise-shi, Mie-ken 516-0021 JAPAN

Telephone : +81 596 24 8999

Facsimile : +81 596 24 8124

**Power Density**

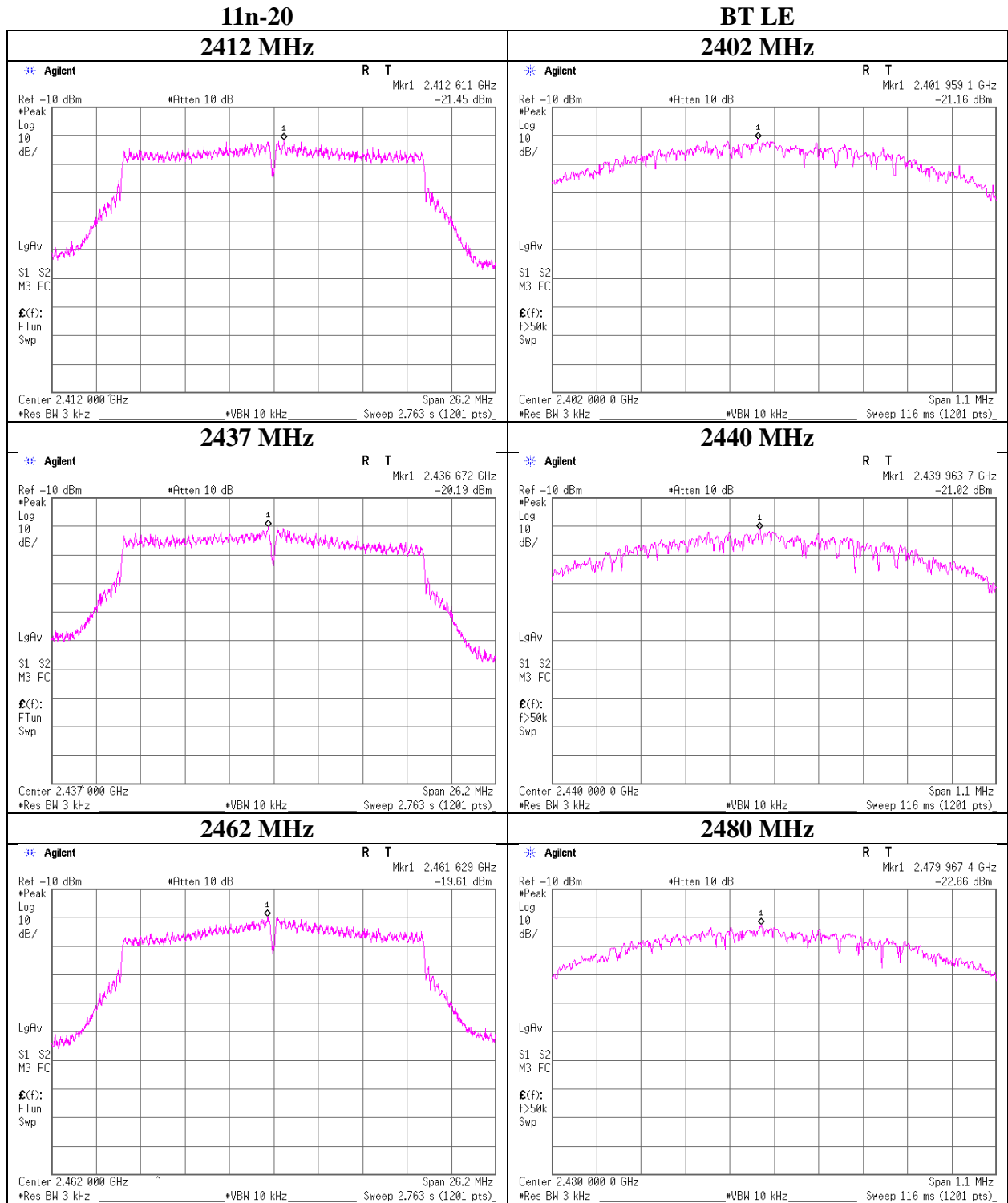

**UL Japan, Inc.**

**Ise EMC Lab.**

4383-326 Asama-cho, Ise-shi, Mie-ken 516-0021 JAPAN

Telephone : +81 596 24 8999

Facsimile : +81 596 24 8124

### 99% Occupied Bandwidth

Test place	Ise EMC Lab. No.6 Measurement Room
Report No.	11500829H
Date	December 13, 2016
Temperature / Humidity	24 deg. C / 31 % RH
Engineer	Yutaka Yoshida
Mode	Tx

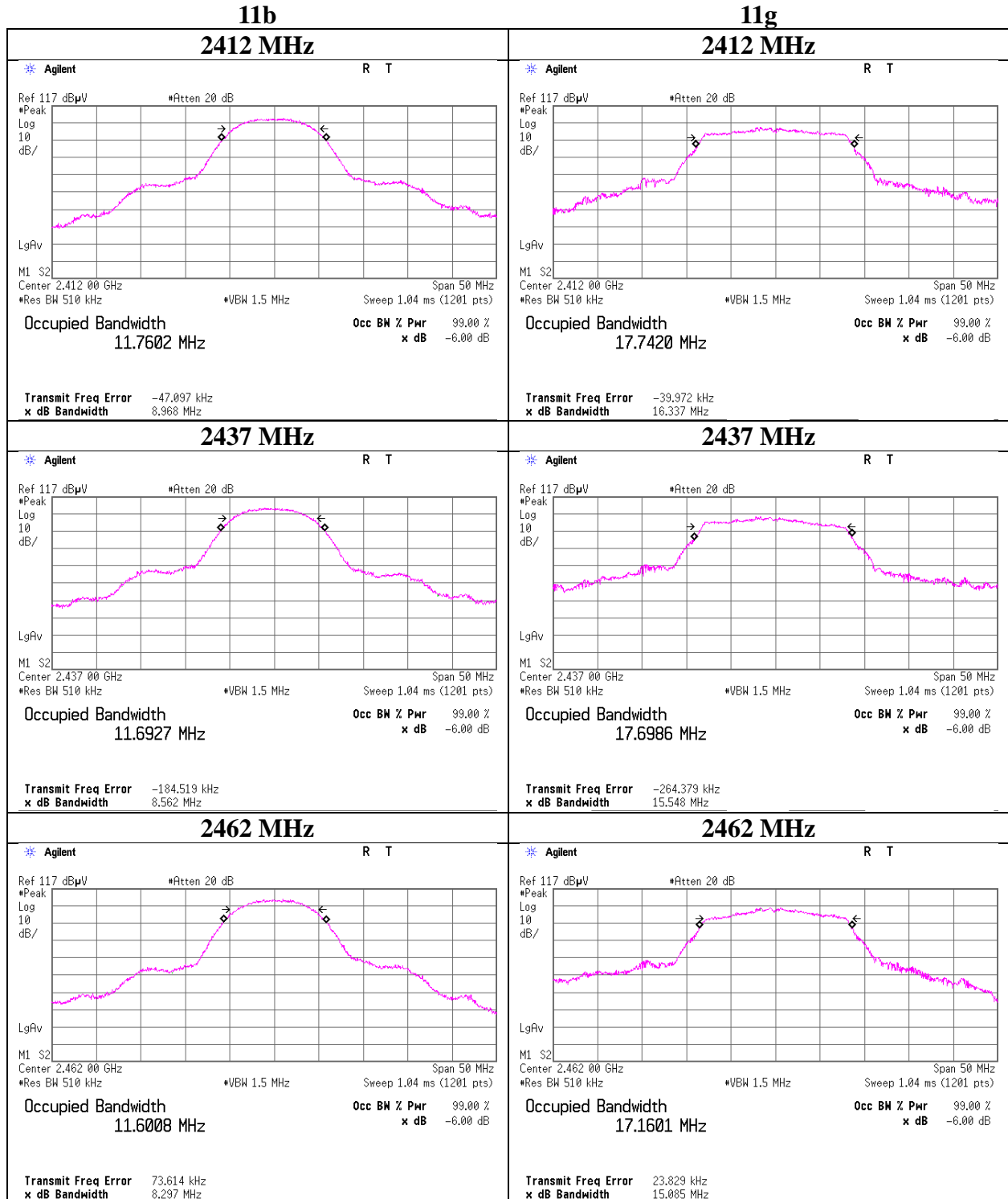

## 99% Occupied Bandwidth

Test place	Ise EMC Lab. No.6 Measurement Room
Report No.	11500829H
Date	December 13, 2016
Temperature / Humidity	24 deg. C / 31 % RH
Engineer	Yutaka Yoshida
Mode	Tx

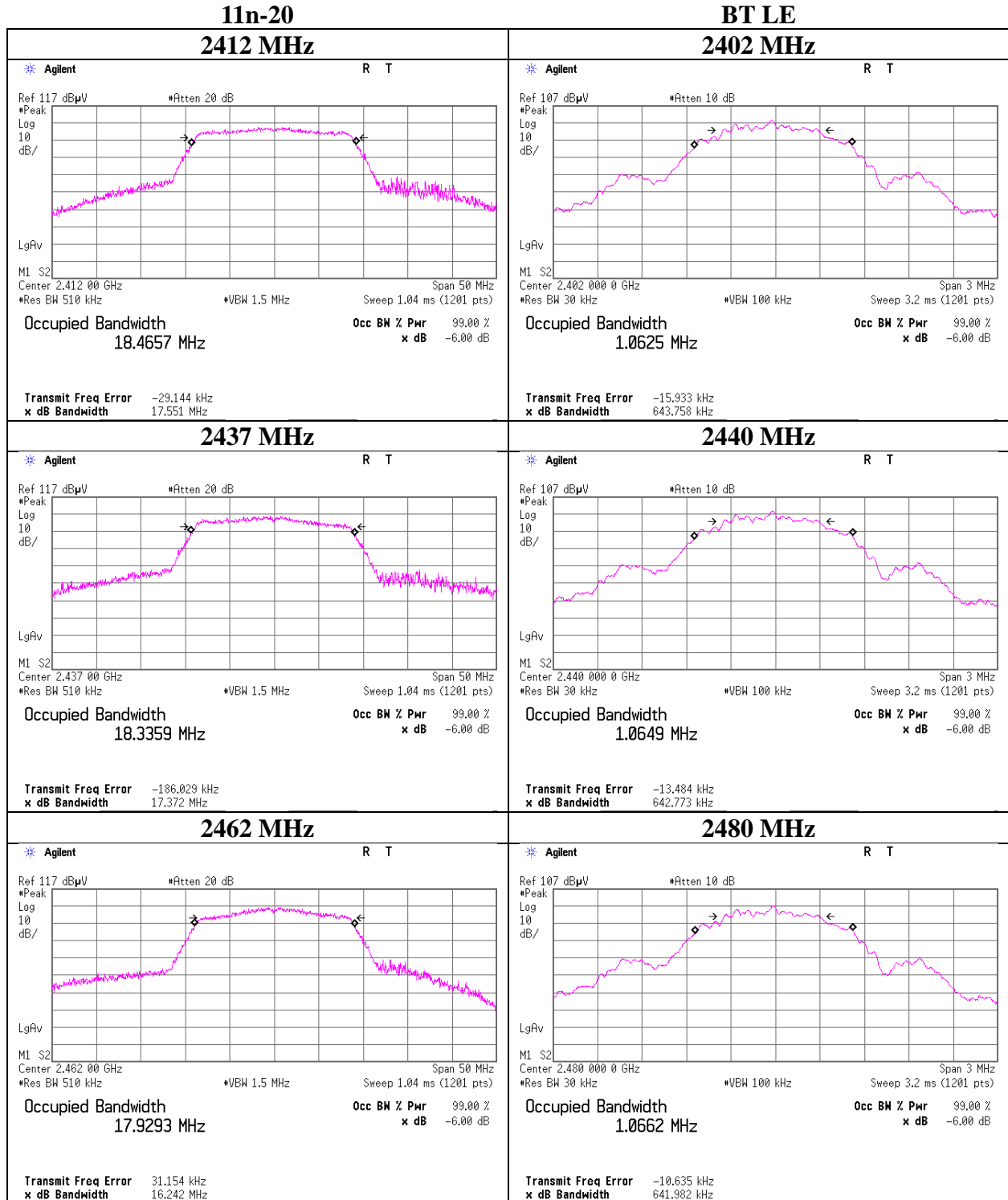

**UL Japan, Inc.**

**Ise EMC Lab.**

4383-326 Asama-cho, Ise-shi, Mie-ken 516-0021 JAPAN

Telephone : +81 596 24 8999

Facsimile : +81 596 24 8124

## **APPENDIX 2: Test instruments**

### **Test equipment**

Control No.	Instrument	Manufacturer	Model No	Serial No	Test Item	Calibration Date * Interval(month)
MOS-14	Thermo-Hygrometer	Custom	CTH-201	1401	AT	2016/01/21 * 12
MSA-10	Spectrum Analyzer	Agilent	E4448A	MY46180655	AT	2016/08/17 * 12
MCC-172	Microwave Cable	Junkosha	MWX221	1409S495	AT	2016/03/11 * 12
MAT-58	Attenuator(10dB)	Suhner	6810.19.A	-	AT	2016/12/15 * 12
MMM-10	DIGITAL HiTESTER	Hioki	3805	051201148	AT	2016/01/18 * 12
MPM-16	Power Meter	Agilent	8990B	MY51000271	AT	2016/04/07 * 12
MPSE-23	Power sensor	Agilent	N1923A	MY54070004	AT	2016/04/07 * 12
MCC-64	Coaxial Cable	UL Japan	-	-	AT	2016/03/10 * 12
MAT-10	Attenuator(10dB)	Weinschel Corp	2	BL1173	AT	2016/11/28 * 12
MAEC-03	Semi Anechoic Chamber(NSA)	TDK	Semi Anechoic Chamber 3m	DA-10005	RE	2016/10/20 * 12
MOS-13	Thermo-Hygrometer	Custom	CTH-180	1301	RE	2016/01/21 * 12
MJM-16	Measure	KOMELON	KMC-36	-	RE	-
COTS-MEMI	EMI measurement program	TSJ	TEPTO-DV	-	RE	-
MSA-16	Spectrum Analyzer	Agilent	E4440A	MY46186390	RE	2016/02/08 * 12
MHA-20	Horn Antenna 1-18GHz	Schwarzbeck	BBHA9120D	258	RE	2016/05/29 * 12
MCC-167	Microwave Cable	Junkosha	MWX221	1404S374(1m) / 1405S074(5m)	RE	2016/05/20 * 12
MPA-11	MicroWave System Amplifier	Agilent	83017A	MY39500779	RE	2016/03/24 * 12
MMM-08	DIGITAL HiTESTER	Hioki	3805	051201197	RE	2016/01/13 * 12
MHF-25	High Pass Filter 3.5-18.0GHz	UL Japan	HPF SELECTOR	001	RE	2016/09/21 * 12
MHA-16	Horn Antenna 15-40GHz	Schwarzbeck	BBHA9170	BBHA9170306	RE	2016/05/29 * 12
MTR-08	Test Receiver	Rohde & Schwarz	ESCI	100767	RE	2016/09/15 * 12
MBA-03	Biconical Antenna	Schwarzbeck	BBA9106	1915	RE	2016/10/15 * 12
MLA-22	Logperiodic Antenna(200-1000MHz)	Schwarzbeck	VUSLP9111B	911B-191	RE	2016/01/30 * 12
MCC-51	Coaxial cable	UL Japan	-	-	RE	2016/07/26 * 12
MAT-98	Attenuator	KEYSIGHT	8491A	MY52462349	RE	2016/12/05 * 12
MPA-13	Pre Amplifier	SONOMA INSTRUMENT	310	260834	RE	2016/03/24 * 12

**The expiration date of the calibration is the end of the expired month.**

**All equipment is calibrated with valid calibrations. Each measurement data is traceable to the national or international standards.**

**As for some calibrations performed after the tested dates, those test equipment have been controlled by means of an unbroken chains of calibrations.**

**Test Item: RE: Radiated Emission test  
AT: Antenna Terminal Conducted test**

**UL Japan, Inc.**

**Ise EMC Lab.**

4383-326 Asama-cho, Ise-shi, Mie-ken 516-0021 JAPAN

Telephone : +81 596 24 8999

Facsimile : +81 596 24 8124