



RADIO TEST REPORT

Test Report No. : 11500829H-B-R1

Applicant : Panasonic Corporation of North America
Type of Equipment : Common Trigger Box
Model No. : WV-TW37003
FCC ID : ACJ9TAWV-TW37003
Test regulation : FCC Part 15 Subpart C: 2016
(*Bluetooth part)
Test Result : Complied

1. This test report shall not be reproduced in full or partial, without the written approval of UL Japan, Inc.
2. The results in this report apply only to the sample tested.
3. This sample tested is in compliance with the above regulation.
4. The test results in this report are traceable to the national or international standards.
5. This test report must not be used by the customer to claim product certification, approval, or endorsement by NVLAP, NIST, or any agency of the Federal Government.
6. This test report covers Radio technical requirements. It does not cover administrative issues such as Manual or non-Radio test related Requirements. (if applicable)
7. This report is a revised version of 11500829H-B. 11500829H-B is replaced with this report.

Date of test: December 12 to 22, 2016

Representative test engineer:

Tomoki Matsui
Engineer
Consumer Technology Division

Approved by:

Tsubasa Takayama
Engineer
Consumer Technology Division



NVLAP LAB CODE: 200572-0

This laboratory is accredited by the NVLAP LAB CODE 200572-0, U.S.A. The tests reported herein have been performed in accordance with its terms of accreditation.
*As for the range of Accreditation in NVLAP, you may refer to the WEB address,
http://japan.ul.com/resources/emc_accredited/

UL Japan, Inc.

Ise EMC Lab.

4383-326 Asama-cho, Ise-shi, Mie-ken 516-0021 JAPAN

Telephone : +81 596 24 8999

Facsimile : +81 596 24 8124

13-EM-F0429

CONTENTS	PAGE
SECTION 1: Customer information.....	4
SECTION 2: Equipment under test (E.U.T.).....	4
SECTION 3: Test specification, procedures & results.....	6
SECTION 4: Operation of E.U.T. during testing.....	9
SECTION 5: Radiated Spurious Emission	12
SECTION 6: Antenna Terminal Conducted Tests.....	13
APPENDIX 1: Test data	14
20dB Bandwidth and Carrier Frequency Separation.....	14
Number of Hopping Frequency	17
Dwell time.....	19
Maximum Peak Output Power	22
Average Output Power	23
Radiated Spurious Emission	25
Conducted Spurious Emission	36
Conducted Emission Band Edge compliance	42
99%Occupied Bandwidth	44
APPENDIX 2: Test instruments	46
APPENDIX 3: Photographs of test setup	47
Radiated Spurious Emission	47
Worst Case Position	48

SECTION 1: Customer information

Applicant

Company Name : Panasonic Corporation of North America
Address : Two Riverfront Plaza, Newark, NJ 07102-5490
Telephone Number : +1-201-348-7724
Facsimile Number : +1-201-392-4564
Contact Person : Vir Angelo Lontoc

Manufacturer

Company Name : Panasonic System Networks Co., Ltd.
Address : 4-1-62, Minoshima, Hakata-ku, Fukuoka 812-8531, Japan
Telephone Number : +81-50-3380-1993
Facsimile Number : +81-50-3380-2002
Contact Person : Yukio Kaneko

***Remarks:**

Panasonic Corporation of North America designates Panasonic System Networks Co., Ltd. as manufacturer of the product (Common Trigger Box).

SECTION 2: Equipment under test (E.U.T.)

2.1 Identification of E.U.T.

Type of Equipment : Common Trigger Box
Model No. : WV-TW37003
Serial No. : Refer to Section 4, Clause 4.2
Rating : DC 12 V, DC 24 V
Receipt Date of Sample : December 10, 2016
Country of Mass-production : Japan
Condition of EUT : Engineering prototype
(Not for Sale: This sample is equivalent to mass-produced items.)
Modification of EUT : No Modification by the test lab

UL Japan, Inc.

Ise EMC Lab.

4383-326 Asama-cho, Ise-shi, Mie-ken 516-0021 JAPAN

Telephone : +81 596 24 8999

Facsimile : +81 596 24 8124

2.2 Product Description

Model: WV-TW37003 (referred to as the EUT in this report) is a Common Trigger Box.

Radio Specification

Radio Type : Transceiver
Power Supply (inner) : DC 4.0 V (POWER), DC 1.8 V (IO)
Clock frequency (crystal) : 37.4 MHz

	IEEE802.11b	IEEE802.11g/n (20 M band)	IEEE802.11a/n/ac (20 M band)	IEEE802.11n/ac (40 M band)	IEEE802.11ac (80 M band)
Frequency of operation	2412 MHz to 2462 MHz	2412 MHz to 2462 MHz	5745 MHz to 5825 MHz	5755 MHz 5795 MHz	5775 MHz
Type of modulation	DSSS (CCK, DQPSK, DBPSK)	OFDM-CCK (64QAM, 16QAM, QPSK, BPSK)	OFDM (64QAM, 16QAM, QPSK, BPSK, 256QAM(IEEE802.11ac only))		
Channel spacing	5MHz		20MHz	40MHz	80MHz
Antenna type	Patterned dipole antenna				
Antenna Connector type	RP-SMA Jack (Female)				
Antenna Gain	-0.8 dBi (2.4 GHz Band), -8.1 dBi (5 GHz Band) *including cable loss				

	Bluetooth Ver.4.1 with EDR function ^{*1)} / Bluetooth Low Energy
Frequency of operation	2402 MHz - 2480 MHz
Type of modulation	BT: FHSS (GFSK, $\pi/4$ -DQPSK, 8-DPSK) LE: GFSK
Channel spacing	BT: 1 MHz LE: 2 MHz
Antenna type	Patterned dipole antenna
Antenna Connector type	RP-SMA Jack (Female)
Antenna Gain	-0.8 dBi *including cable loss

*1) This test report applies to Bluetooth.

*Wireless LAN and Bluetooth do not transmit simultaneously.

SECTION 3: Test specification, procedures & results

3.1 Test Specification

Test Specification : FCC Part 15 Subpart C
FCC Part 15 final revised on November 14, 2016 and effective December 14, 2016

Title : FCC 47CFR Part15 Radio Frequency Device Subpart C Intentional Radiators
Section 15.207 Conducted limits
Section 15.247 Operation within the bands 902-928MHz,
2400-2483.5MHz, and 5725-5850MHz

* The revision on November 14, 2016, does not affect the test specification applied to the EUT.

3.2 Procedures and results

Item	Test Procedure	Specification	Worst Margin	Results	Remarks
Conducted Emission	FCC: ANSI C63.10-2013 6. Standard test methods IC: RSS-Gen 8.8	FCC: Section 15.207 IC: RSS-Gen 8.8	-	N/A *1)	-
Carrier Frequency Separation	FCC: FCC Public Notice DA 00-705 IC: -	FCC: Section15.247(a)(1) IC: RSS-247 5.1 (2)	See data.	Complied	Conducted
20dB Bandwidth	FCC: FCC Public Notice DA 00-705 IC: -	FCC: Section15.247(a)(1) IC: RSS-247 5.1 (1)		Complied	Conducted
Number of Hopping Frequency	FCC: FCC Public Notice DA 00-705 IC: -	FCC: Section15.247(a)(1)(iii) IC: RSS-247 5.1 (4)		Complied	Conducted
Dwell time	FCC: FCC Public Notice DA 00-705 IC: -	FCC: Section15.247(a)(1)(iii) IC: RSS-247 5.1 (4)		Complied	Conducted
Maximum Peak Output Power	FCC: FCC Public Notice DA 00-705 IC: RSS-Gen 6.12	FCC: Section15.247(a)(b)(1) IC: RSS-247 5.4 (2)		Complied	Conducted
Spurious Emission & Band Edge Compliance	FCC: FCC Public Notice DA 00-705 IC: RSS-Gen 6.13	FCC: Section15.247(d) IC: RSS-247 5.5 RSS-Gen 8.9 RSS-Gen 8.10	2.6 dB 1150.000 MHz, Vertical, AV	Complied	Conducted/ Radiated (above 30 MHz) *2)

Note: UL Japan, Inc.'s EMI Work Procedures No. 13-EM-W0420 and 13-EM-W0422.

*1) The test is not applicable since the EUT is not the device that is designed to be connected to the public utility (AC) power line.

*2) Radiated test was selected over 30 MHz based on section 15.247(d).

* In case any questions arise about test procedure, ANSI C63.10: 2013 is also referred.

FCC Part 15.31 (e)

The EUT provides stable voltage (DC 4.0 V, DC 1.8 V) constantly to the wireless transmitter regardless of input voltage. The test was performed with DC 12.0 V by using DC power supply.

That does not affect the test result, therefore the EUT complies with the requirement.

FCC Part 15.203 Antenna requirement

The EUT has a unique coupling/antenna connector (RP-SMA Jack). Therefore the equipment complies with the requirement of 15.203.

UL Japan, Inc.

Ise EMC Lab.

4383-326 Asama-cho, Ise-shi, Mie-ken 516-0021 JAPAN

Telephone : +81 596 24 8999

Facsimile : +81 596 24 8124

3.3 Addition to standard

Item	Test Procedure	Specification	Worst margin	Results	Remarks
99% Occupied Bandwidth	IC: RSS-Gen 6.6	IC: -	N/A	-	Conducted

Other than above, no addition, exclusion nor deviation has been made from the standard.

3.4 Uncertainty

EMI

The following uncertainties have been calculated to provide a confidence level of 95 % using a coverage factor $k = 2$.

Ise EMC Lab.

Antenna terminal test Uncertainty (+/-)							
Power meter		Conducted emission and Power density			Conducted emission		Channel power
Below 1 GHz	Above 1 GHz	Below 1 GHz	1 GHz - 3 GHz	3 GHz - 18 GHz	18 GHz - 26.5 GHz	26.5 GHz - 40 GHz	
0.9 dB	1.0 dB	1.4 dB	1.5 dB	2.8 dB	2.8 dB	2.9 dB	2.6 dB

Test distance	Radiated emission (+/-) 9 kHz - 30 MHz
3m	3.8 dB
10m	3.7 dB

Polarity	Radiated emission (Below 1GHz)			
	(3 m*) (+/-)		(10 m*) (+/-)	
	30 - 200 MHz	200 - 1000MHz	30 - 200 MHz	200 - 1000MHz
Horizontal	5.0 dB	5.3 dB	5.0 dB	5.0 dB
Vertical	4.7 dB	5.9 dB	5.0 dB	5.1 dB

Radiated emission (Above 1GHz)				
(3 m*) (+/-)		(1 m*) (+/-)		(10 m*) (+/-)
1 - 6GHz	6 - 18GHz	10 - 26.5 GHz	26.5 - 40GHz	1 - 18 GHz
5.2 dB	5.4 dB	5.5 dB	5.5 dB	5.4 dB

*Measurement distance

Radiated emission test

The data listed in this report meets the limits unless the uncertainty is taken into consideration.

3.5 Test Location

UL Japan, Inc. Ise EMC Lab. *NVLAP Lab. code: 200572-0
4383-326 Asama-cho, Ise-shi, Mie-ken 516-0021 JAPAN
Telephone: +81 596 24 8999, Facsimile: +81 596 24 8124

Test site	IC Registration Number	Width x Depth x Height (m)	Size of reference ground plane (m) / horizontal conducting plane	Other rooms	Maximum measurement distance
No.1 semi-anechoic chamber	2973C-1	19.2 x 11.2 x 7.7	7.0 x 6.0	No.1 Power source room	10 m
No.2 semi-anechoic chamber	2973C-2	7.5 x 5.8 x 5.2	4.0 x 4.0	-	3 m
No.3 semi-anechoic chamber	2973C-3	12.0 x 8.5 x 5.9	6.8 x 5.75	No.3 Preparation room	3 m
No.3 shielded room	-	4.0 x 6.0 x 2.7	N/A	-	-
No.4 semi-anechoic chamber	2973C-4	12.0 x 8.5 x 5.9	6.8 x 5.75	No.4 Preparation room	3 m
No.4 shielded room	-	4.0 x 6.0 x 2.7	N/A	-	-
No.5 semi-anechoic chamber	-	6.0 x 6.0 x 3.9	6.0 x 6.0	-	-
No.6 shielded room	-	4.0 x 4.5 x 2.7	4.0 x 4.5	-	-
No.6 measurement room	-	4.75 x 5.4 x 3.0	4.75 x 4.15	-	-
No.7 shielded room	-	4.7 x 7.5 x 2.7	4.7 x 7.5	-	-
No.8 measurement room	-	3.1 x 5.0 x 2.7	N/A	-	-
No.9 measurement room	-	8.8 x 4.6 x 2.8	2.4 x 2.4	-	-
No.11 measurement room	-	6.2 x 4.7 x 3.0	4.8 x 4.6	-	-

* Size of vertical conducting plane (for Conducted Emission test) : 2.0 m x 2.0 m for No.1, No.2, No.3, and No.4 semi-anechoic chambers and No.3 and No.4 shielded rooms.

3.6 Test data, Test instruments, and Test set up

Refer to APPENDIX.

UL Japan, Inc.

Ise EMC Lab.

4383-326 Asama-cho, Ise-shi, Mie-ken 516-0021 JAPAN

Telephone : +81 596 24 8999

Facsimile : +81 596 24 8124

SECTION 4: Operation of E.U.T. during testing

4.1 Operating Mode(s)

Bluetooth (BT): Transmitting (Tx), Payload: PRBS9

Details of Operating Mode(s)

Test Item	Mode	Tested frequency
Spurious Emission (Conducted/Radiated)	Tx (Hopping Off) DH5, 3DH5	2402 MHz 2441 MHz 2480 MHz
Carrier Frequency Separation	Tx (Hopping On) DH5, 3DH5	2402 MHz 2441 MHz 2480 MHz
20dB Bandwidth	Tx (Hopping Off) DH5, 3DH5	2402 MHz 2441 MHz 2480 MHz
Number of Hopping Frequency	Tx (Hopping On) DH5, 3DH5	-
Dwell time	Tx (Hopping On), -DH1, DH3, DH5 -3DH1, 3DH3, 3DH5	-
Maximum Peak Output Power	Tx (Hopping Off) DH5, 2DH5, 3DH5	2402 MHz 2441 MHz 2480 MHz
Band Edge Compliance (Conducted)	Tx DH5, 3DH5 -Hopping On -Hopping Off	2402 MHz 2480 MHz
99% Occupied Bandwidth	Tx DH5, 3DH5 -Hopping On -Hopping Off	2402 MHz 2441 MHz 2480 MHz
<p>*As a result of preliminary test, the formal test was performed with the above modes, which had the maximum payload length (except Dwell time test)</p> <p>*2DH mode (2Mb/s EDR: pi/4DQPSK) was excluded for other tests than power measurement by using 3DH mode (3 Mb/s EDR: 8DPSK) as a representative.</p> <p>* It is considered that the non-tested packet type (e.g. inquiry) can be omitted as it is complied with above all the test items based on Bluetooth Core specification.</p> <p>*The power value of the EUT was set for testing as follows (setting value might be different from product specification value); Power settings: EDR: -1 dBm BDR: 5 dBm Software: BLUETest3 *This setting of software is the worst case. Any conditions under the normal use do not exceed the condition of setting. In addition, end users cannot change the settings of the output power of the product.</p>		

4.2 Configuration and peripherals

For Radiated Spurious Emission test

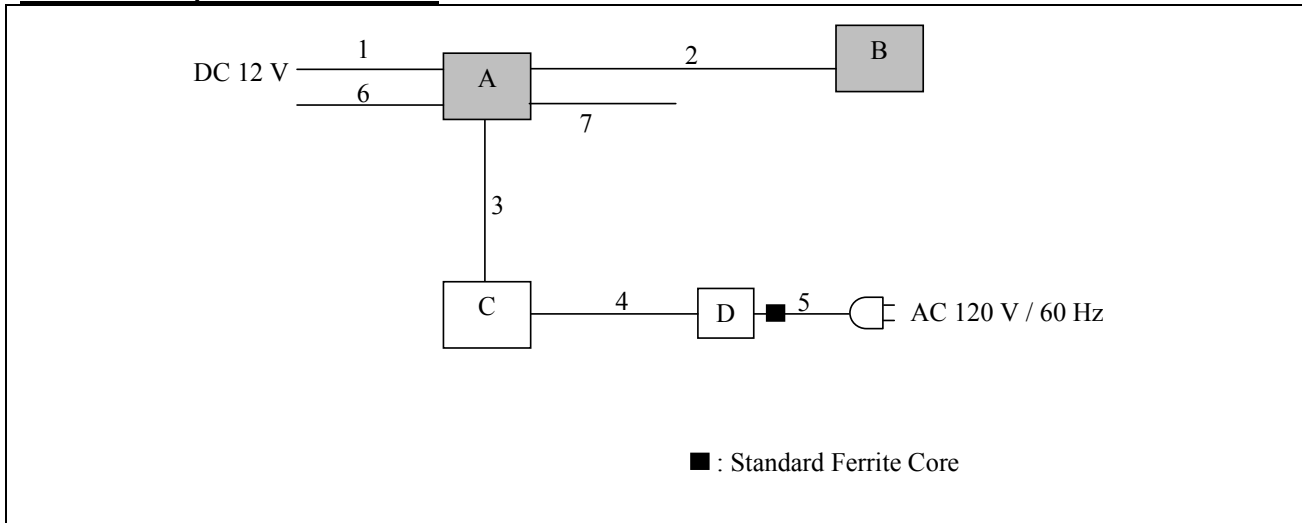

* Cabling and setup(s) were taken into consideration and test data was taken under worse case conditions.

Description of EUT and Support equipment

No.	Item	Model number	Serial number	Manufacturer	Remarks
A	Common Trigger Box	WV-TW37003	001	Panasonic System Networks Co., Ltd.	EUT
B	Antenna	AP-W-M-S2-R P-WH	001	ANTENNA PLUS	EUT
C	Laptop PC	T60	L3-DM302	IBM	-
D	AC Adapter	92P1160	11S92P1160Z1ZBGH6B6DKV	IBM	-

List of cables used

No.	Name	Length (m)	Shield		Remarks
			Cable	Connector	
1	DC Cable	2.0	Unshielded	Unshielded	-
2	Antenna Cable	3.0	Shielded	Shielded	-
3	LAN Cable	3.0	Unshielded	Unshielded	-
4	DC Cable	1.8	Unshielded	Unshielded	-
5	AC Cable	0.9	Unshielded	Unshielded	-
6	Signal Cable	1.0	Unshielded	Unshielded	-
7	Flat Cable	0.12	Unshielded	Unshielded	-

UL Japan, Inc.

Ise EMC Lab.

4383-326 Asama-cho, Ise-shi, Mie-ken 516-0021 JAPAN

Telephone : +81 596 24 8999

Facsimile : +81 596 24 8124

For Antenna Terminal Conducted Tests

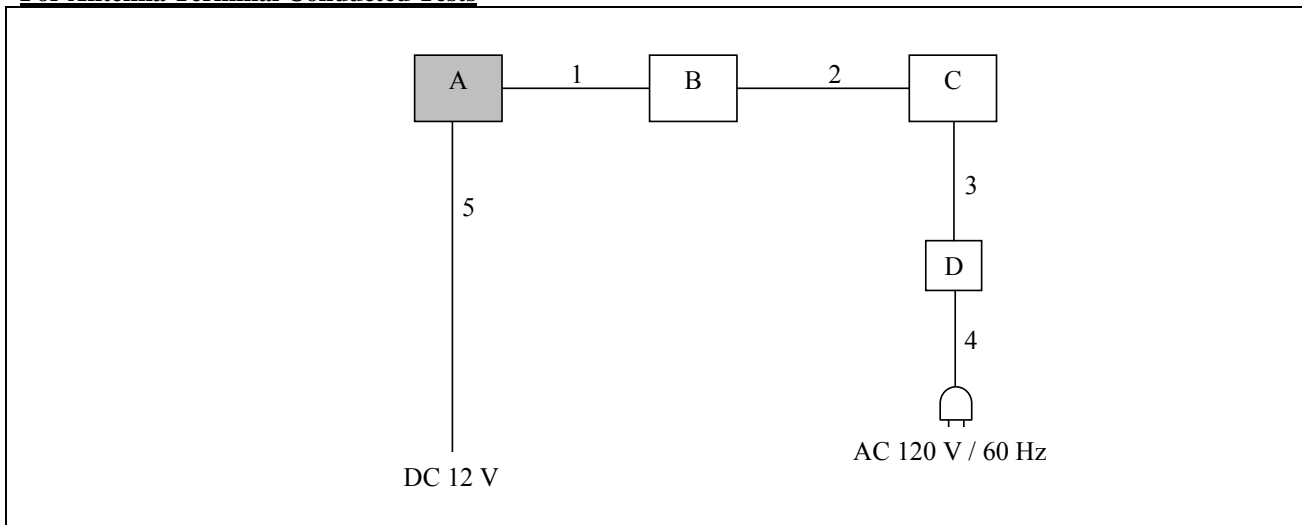

* Cabling and setup(s) were taken into consideration and test data was taken under worse case conditions.

Description of EUT and Support equipment

No.	Item	Model number	Serial number	Manufacturer	Remarks
A	Common Trigger Box	WV-TW37003	002	Panasonic System Networks Co., Ltd.	EUT
B	Jig	-	-	-	-
C	Laptop PC	T450	0715PC06BG66	Lenovo	-
D	AC Adapter	ADLX65NCC2A	11S45N0263Z1ZS995578FZ	Lenovo	-

List of cables used

No.	Name	Length (m)	Shield		Remarks
			Cable	Connector	
1	Flat Cable	0.12	Unshielded	Unshielded	-
2	USB Cable	0.7	Unshielded	Unshielded	-
3	DC Cable	1.6	Unshielded	Unshielded	-
4	AC Cable	0.8	Unshielded	Unshielded	-
5	DC Cable	0.6	Unshielded	Unshielded	-

UL Japan, Inc.

Ise EMC Lab.

4383-326 Asama-cho, Ise-shi, Mie-ken 516-0021 JAPAN

Telephone : +81 596 24 8999

Facsimile : +81 596 24 8124

SECTION 5: Radiated Spurious Emission

Test Procedure

[For below 1 GHz]

EUT was placed on a urethane platform of nominal size, 1.0 m by 1.5 m, raised 0.8 m above the conducting ground plane. The Radiated Electric Field Strength has been measured in a Semi Anechoic Chamber with a ground plane.

[For above 1 GHz]

EUT was placed on a urethane platform of nominal size, 0.5 m by 0.5 m, raised 1.5 m above the conducting ground plane.

The Radiated Electric Field Strength has been measured in a Semi Anechoic Chamber with absorbent materials lined on a ground plane.

The height of the measuring antenna varied between 1 and 4 m and EUT was rotated a full revolution in order to obtain the maximum value of the electric field strength.

The measurements were performed for both vertical and horizontal antenna polarization with the Test Receiver, or the Spectrum Analyzer.

The measurements were made with the following detector function of the test receiver and the Spectrum analyzer (in linear mode).

The test was made with the detector (RBW/VBW) in the following table.

When using Spectrum analyzer, the test was made with adjusting span to zero by using peak hold.

Test Antennas are used as below;

Frequency	30 MHz to 200 MHz	200 MHz to 1 GHz	Above 1 GHz
Antenna Type	Biconical	Logperiodic	Horn

In any 100 kHz bandwidth outside the restricted band in which the spread spectrum intentional radiator is operating, the radio frequency power that is produced by the intentional radiator confirmed 20 dB below that in the 100 kHz bandwidth within the band that contains the highest level of the desired power, based on a radiated measurement.

20 dBc was applied to the frequency over the limit of FCC 15.209 / Table 4 of RSS-Gen 8.9 (IC) and outside the restricted band of FCC15.205 / Table 6 of RSS-Gen 8.10 (IC).

Frequency	Below 1 GHz	Above 1 GHz		20 dBc
Instrument used	Test Receiver	Spectrum Analyzer		Spectrum Analyzer
Detector	QP	PK	AV	PK
IF Bandwidth	BW 120 kHz	RBW: 1 MHz VBW: 3 MHz	RBW: 1 MHz VBW: 10 Hz *1)	RBW: 100 kHz VBW: 300 kHz
Test Distance	3 m	4.45 m*2) (1 GHz – 10 GHz), 1 m*3) (10 GHz – 26.5 GHz)		4.45 m*2) (1 GHz – 10 GHz), 1 m*3) (10 GHz – 26.5 GHz)

*1) Although DA 00-705 accepts VBW = 10 Hz for AV measurements, it was confirmed that superfluous smoothing was not performed.

*2) Distance Factor: $20 \times \log(4.45 \text{ m}/3.0 \text{ m}) = 3.43 \text{ dB}$

*3) Distance Factor: $20 \times \log(1.0 \text{ m}/3.0 \text{ m}) = -9.5 \text{ dB}$

- The carrier level and noise levels were confirmed at each position of X, Y and Z axes of EUT (Common Trigger Box and antenna) to see the position of maximum noise, and the test was made at the position that has the maximum noise.

The test results and limit are rounded off to one decimal place, so some differences might be observed.

Measurement range : 30 MHz - 26.5 GHz
Test data : APPENDIX
Test result : Pass

UL Japan, Inc.

Ise EMC Lab.

4383-326 Asama-cho, Ise-shi, Mie-ken 516-0021 JAPAN

Telephone : +81 596 24 8999

Facsimile : +81 596 24 8124

SECTION 6: Antenna Terminal Conducted Tests

Test Procedure

The tests were made with below setting connected to the antenna port.

Test	Span	RBW	VBW	Sweep time	Detector	Trace	Instrument used
20dB Bandwidth	3 MHz	30 kHz	100 kHz	Auto	Peak	Max Hold	Spectrum Analyzer
99% Occupied Bandwidth *1)	Enough width to display emission skirts	1 to 5 % of OBW	Three times of RBW	Auto	Peak	Max Hold	Spectrum Analyzer
Maximum Peak Output Power	-	-	-	Auto	Peak Average *2)	-	Power Meter (Sensor: 50MHz BW)
Carrier Frequency Separation	3 MHz	30 kHz	100 kHz	Auto	Peak	Max Hold	Spectrum Analyzer
Number of Hopping Frequency	30 MHz	300 kHz	1 MHz	Auto	Peak	Max Hold	Spectrum Analyzer
Dwell Time	Zero Span	100 kHz, 1 MHz	300 kHz, 3 MHz	As necessary capture the entire dwell time per hopping channel	Peak	Clear Write	Spectrum Analyzer
Conducted Spurious Emission *3)	9 kHz to 150 kHz	200 Hz	620 Hz	Auto	Peak	Max Hold	Spectrum Analyzer
	150 kHz to 30 MHz	9.1 kHz	27 kHz				
	30 MHz to 25 GHz	100 kHz	300 kHz				
Conducted Spurious Emission Band Edge compliance	10 MHz	100 kHz	300 kHz	Auto	Peak	Max Hold	Spectrum Analyzer

*1) Peak hold was applied as Worst-case measurement.

*2) Reference data

*3) In the frequency range below 30MHz, RBW was narrowed to separate the noise contents.

Then, wide-band noise near the limit was checked separately, however the noise was not detected as shown in the chart.

(9 kHz -150 kHz: RBW = 200 Hz, 150 kHz - 30 MHz: RBW = 9.1 kHz)

The test results and limit are rounded off to two decimals place, so some differences might be observed.

Test data : APPENDIX
Test result : Pass

APPENDIX 1: Test data

20dB Bandwidth and Carrier Frequency Separation

Test place Ise EMC Lab. No.6 Measurement Room
Report No. 11500829H
Date December 12, 2016
Temperature / Humidity 26 deg. C / 24 % RH
Engineer Yutaka Yoshida
Mode Tx, Hopping Off, DH5

Mode	Freq. [MHz]	20dB Bandwidth [MHz]	Carrier Frequency Separation [MHz]	Limit for Carrier Frequency separation [MHz]
DH5	2402.0	1.034	1.000	≥ 0.689
DH5	2441.0	1.028	1.000	≥ 0.685
DH5	2480.0	1.052	1.000	≥ 0.701
3DH5	2402.0	1.314	1.000	≥ 0.876
3DH5	2441.0	1.321	1.000	≥ 0.881
3DH5	2480.0	1.326	1.000	≥ 0.884

Limit: Two-thirds of 20dB Bandwidth or 25kHz (whichever is greater).

No limit applies to 20dB Bandwidth.

20dB Bandwidth and Carrier Frequency Separation

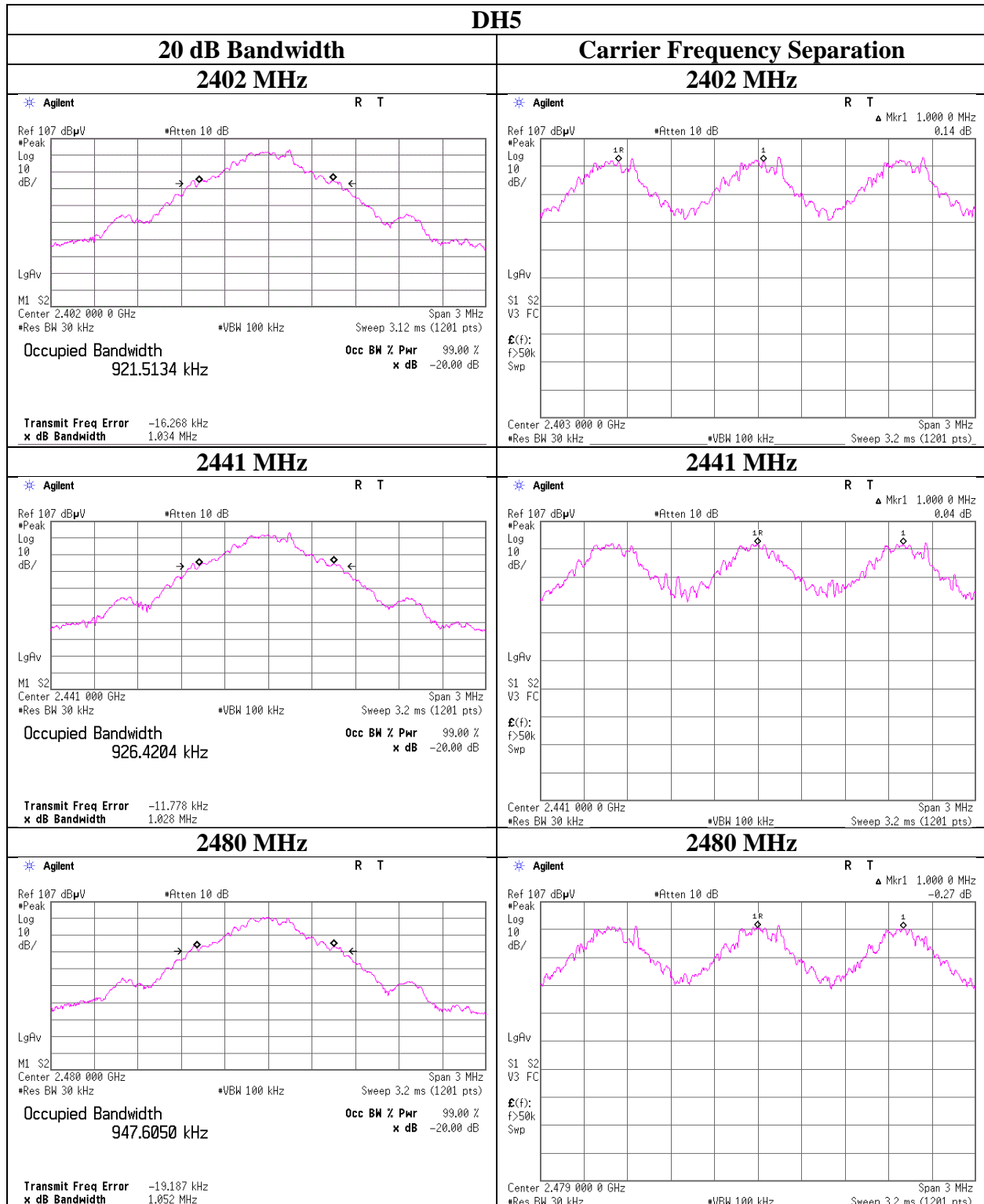

UL Japan, Inc.

Ise EMC Lab.

4383-326 Asama-cho, Ise-shi, Mie-ken 516-0021 JAPAN

Telephone : +81 596 24 8999

Facsimile : +81 596 24 8124

20dB Bandwidth and Carrier Frequency Separation

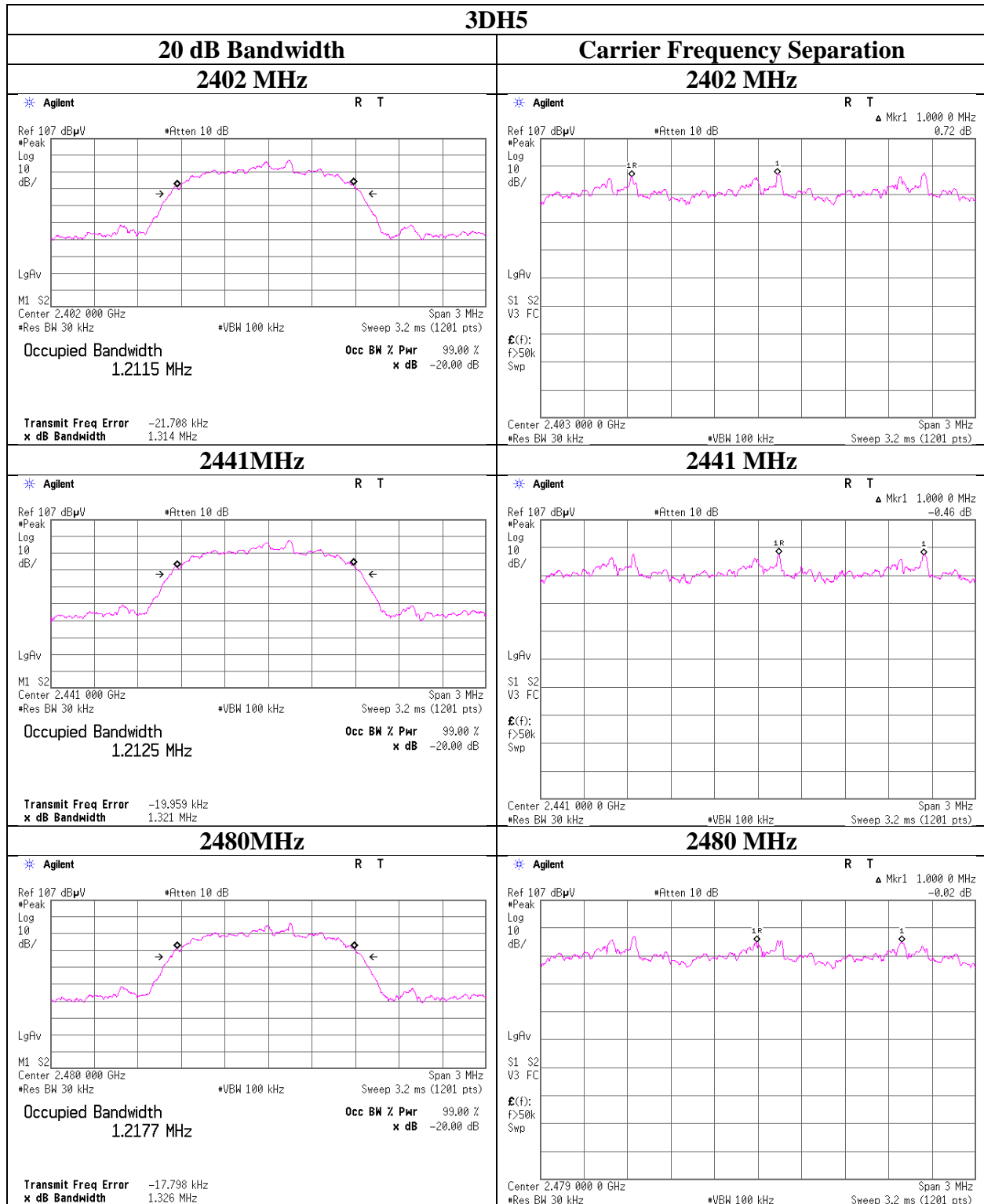

UL Japan, Inc.

Ise EMC Lab.

4383-326 Asama-cho, Ise-shi, Mie-ken 516-0021 JAPAN

Telephone : +81 596 24 8999

Facsimile : +81 596 24 8124

Number of Hopping Frequency

Test place Ise EMC Lab. No.6 Measurement Room
Report No. 11500829H
Date December 12, 2016
Temperature / Humidity 26 deg. C / 24 % RH
Engineer Yutaka Yoshida
Mode Tx, Hopping On

Mode	Number of channel [channels]	Limit [channels]
DH5	79	≥ 15
3DH5	79	≥ 15

Test was not performed at AFH mode whose number of hopping channel is 20 channels because this Bluetooth radio is in compliance of Bluetooth Specification.

Number of Hopping Frequency

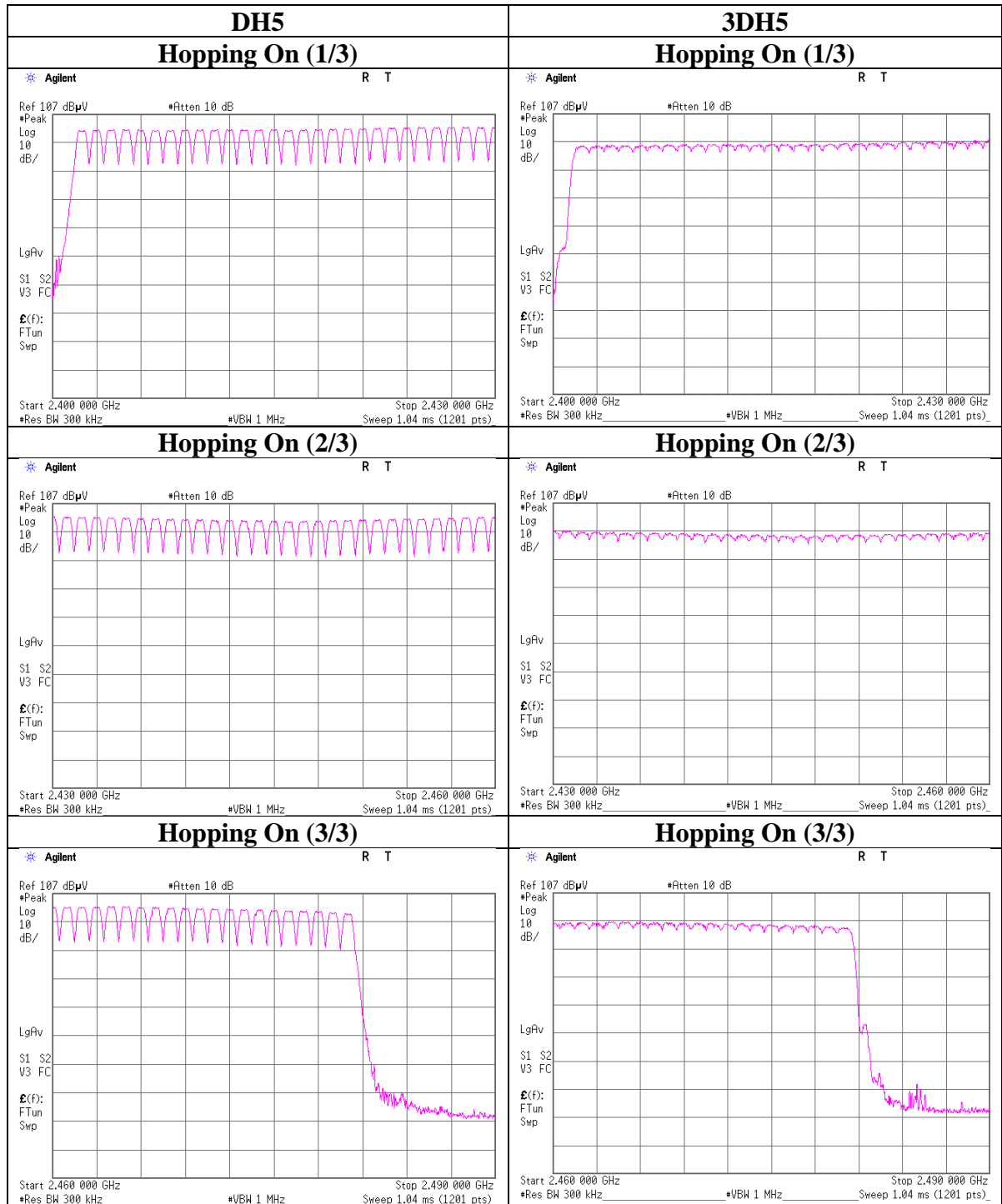

Dwell time

Test place Ise EMC Lab. No.6 Measurement Room
Report No. 11500829H
Date December 12, 2016
Temperature / Humidity 26 deg. C / 23 % RH
Engineer Yutaka Yoshida
Mode Tx, Hopping On

Mode	Number of transmission in a 31.6(79 Hopping x 0.4) / 12.8 (32 Hopping x 0.4) second period			Length of transmission [msec]	Result [msec]	Limit [msec]
DH1	50.0 times /	5 sec. x	31.6 sec. =	316 times	0.422	400
DH3	23.0 times /	5 sec. x	31.6 sec. =	146 times	1.682	400
DH5	16.2 times /	5 sec. x	31.6 sec. =	103 times	2.930	400
3DH1	49.4 times /	5 sec. x	31.6 sec. =	313 times	0.430	400
3DH3	23.6 times /	5 sec. x	31.6 sec. =	150 times	1.682	400
3DH5	15.6 times /	5 sec. x	31.6 sec. =	99 times	2.937	400

Sample Calculation

Result = Number of transmission x Length of transmission

*Average data of 5 tests.(except Inquiry)

Mode	Sampling [times]					Average [times]
	1	2	3	4	5	
DH1	50	51	49	50	50	50
DH3	24	22	24	23	22	23
DH5	12	16	17	15	21	16.2
3DH1	48	51	49	50	49	49.4
3DH3	25	22	22	25	24	23.6
3DH5	16	15	15	19	13	15.6

Sample Calculation

Average = Summation (Sampling 1 to 5) / 5

This device complies with the Bluetooth protocol for FHSS operation, employing a pseudo random channel selection and hopping rate to ensure that the occupancy time in $N \times 0.4s$, where N is the number of channels being used in the hopping sequence ($20 \leq N \leq 79$), is always less than $0.4s$ regardless of packet size. This is confirmed in the test report for $N = 79$.

Dwell time

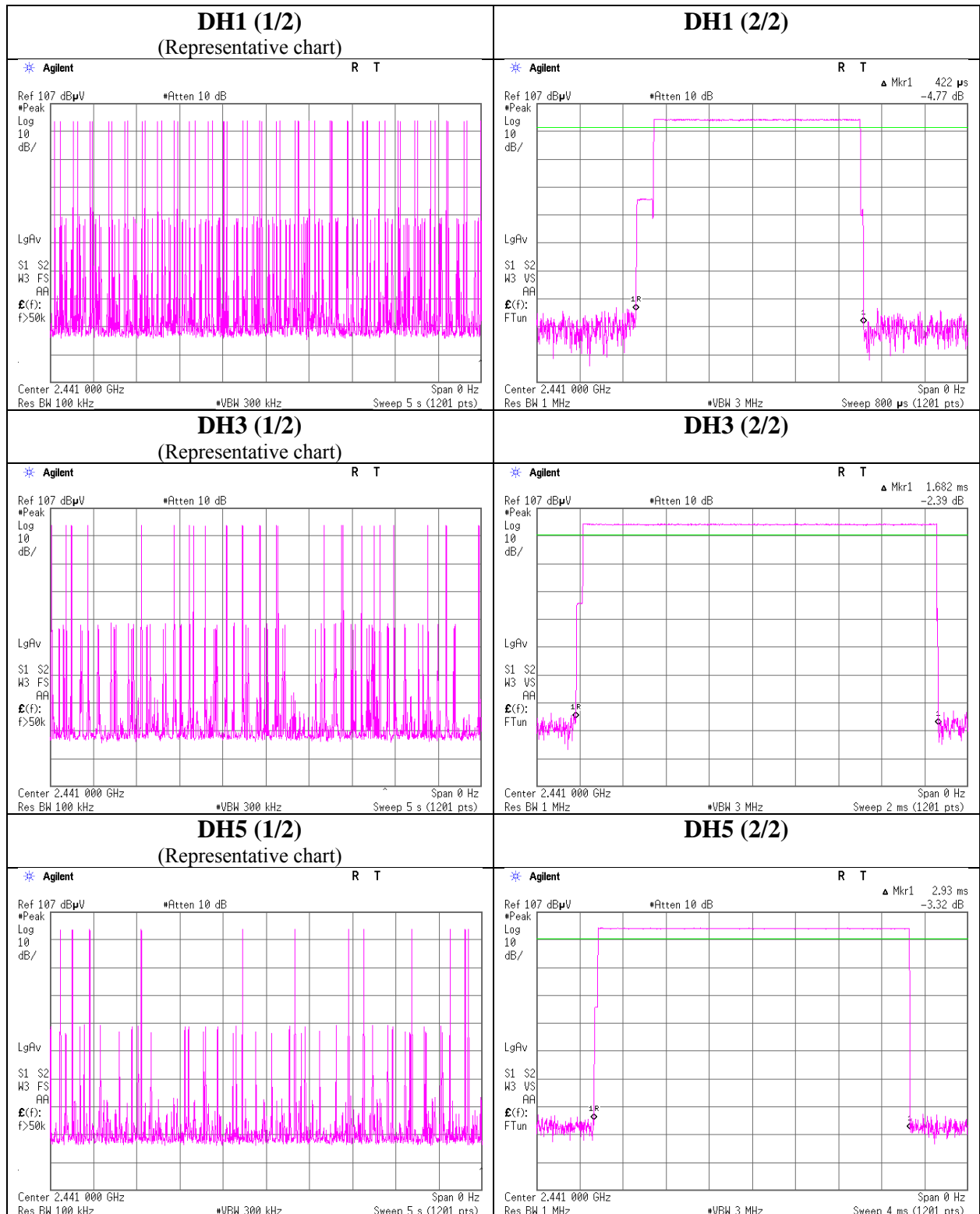

UL Japan, Inc.

Ise EMC Lab.

4383-326 Asama-cho, Ise-shi, Mie-ken 516-0021 JAPAN

Telephone : +81 596 24 8999

Facsimile : +81 596 24 8124

Dwell time

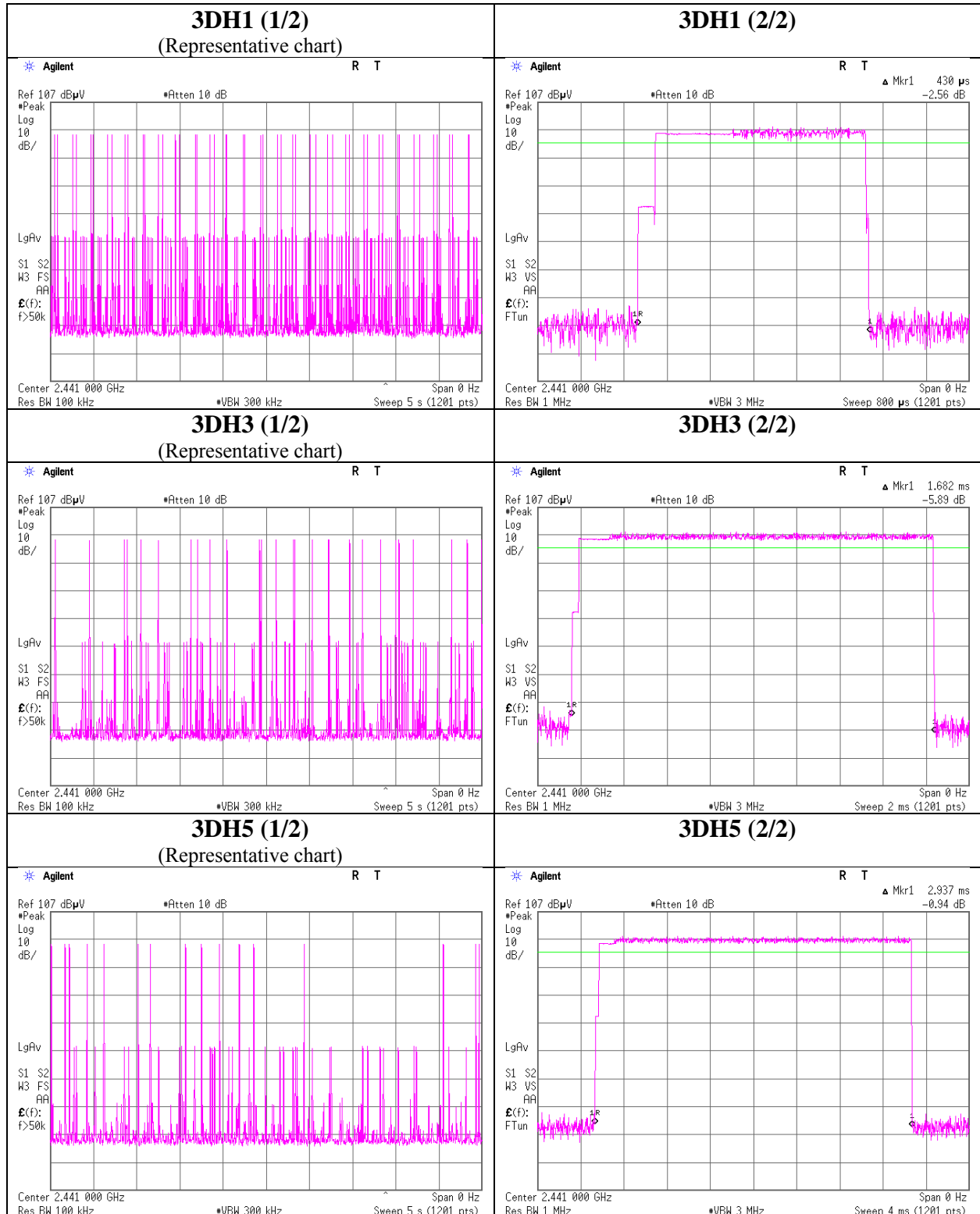

UL Japan, Inc.

Ise EMC Lab.

4383-326 Asama-cho, Ise-shi, Mie-ken 516-0021 JAPAN

Telephone : +81 596 24 8999

Facsimile : +81 596 24 8124

Maximum Peak Output Power

Test place : Ise EMC Lab. No.6 Measurement Room
Report No. : 11500829H
Date : December 12, 2016
Temperature / Humidity : 26 deg. C / 23 % RH
Engineer : Yutaka Yoshida
Mode : Tx, Hopping Off

Mode	Freq. [MHz]	Reading [dBm]	Cable Loss [dB]	Atten. Loss [dB]	Result		Limit		Margin [dB]
					[dBm]	[mW]	[dBm]	[mW]	
DH5	2402.0	-5.53	1.51	10.06	6.04	4.02	20.96	125	14.92
DH5	2441.0	-5.66	1.52	10.06	5.92	3.91	20.96	125	15.04
DH5	2480.0	-6.93	1.53	10.06	4.66	2.92	20.96	125	16.30
2DH5	2402.0	-8.91	1.51	10.06	2.66	1.85	20.96	125	18.30
2DH5	2441.0	-8.52	1.52	10.06	3.06	2.02	20.96	125	17.90
2DH5	2480.0	-9.74	1.53	10.06	1.85	1.53	20.96	125	19.11
3DH5	2402.0	-8.59	1.51	10.06	2.98	1.99	20.96	125	17.98
3DH5	2441.0	-8.18	1.52	10.06	3.40	2.19	20.96	125	17.56
3DH5	2480.0	-9.56	1.53	10.06	2.03	1.60	20.96	125	18.93

Sample Calculation:

Result = Reading + Cable Loss (including the cable(s) customer supplied) + Attenuator Loss

Test was not performed at AFH mode, because the decrease of number of channel (min: 20ch) at AFH mode does not influence on the output power and bandwidth of the EUT.

As this device had AFH mode and frequency separation could not meet the requirement of over 20dB BW without 2/3 relaxation, 125mW power limit was applied to it.

Average Output Power
(Reference data for RF Exposure)

Test place : Ise EMC Lab. No.6 Measurement Room
Report No. : 11500829H
Date : December 12, 2016
Temperature / Humidity : 26 deg. C / 23 % RH
Engineer : Yutaka Yoshida
Mode : Tx, Hopping Off

Mode	Freq. [MHz]	Reading [dBm]	Cable Loss [dB]	Atten. Loss [dB]	Result (Time average)		Duty factor [dB]	Result (Burst power average)	
					[dBm]	[mW]		[dBm]	[mW]
DH5	2402.0	-6.82	1.51	10.06	4.75	2.99	1.08	5.83	3.83
DH5	2441.0	-6.93	1.52	10.06	4.65	2.92	1.08	5.73	3.74
DH5	2480.0	-8.26	1.53	10.06	3.33	2.15	1.08	4.41	2.76
2DH5	2402.0	-12.69	1.51	10.06	-1.12	0.77	1.07	-0.05	0.99
2DH5	2441.0	-12.17	1.52	10.06	-0.59	0.87	1.07	0.48	1.12
2DH5	2480.0	-13.51	1.53	10.06	-1.92	0.64	1.07	-0.85	0.82
3DH5	2402.0	-12.56	1.51	10.06	-0.99	0.80	1.07	0.08	1.02
3DH5	2441.0	-12.16	1.52	10.06	-0.58	0.87	1.07	0.49	1.12
3DH5	2480.0	-13.51	1.53	10.06	-1.92	0.64	1.07	-0.85	0.82

Sample Calculation:

Result (Time average) = Reading + Cable Loss (including the cable(s) customer supplied) + Attenuator Loss

Result (Burst power average) = Time average + Duty factor

Burst Rate Confirmation

Test place	Ise EMC Lab. No.6 Measurement Room
Report No.	11500829H
Date	December 12, 2016
Temperature / Humidity	26 deg. C / 23 % RH
Engineer	Yutaka Yoshida
Mode	Tx, Hopping Off

DH5

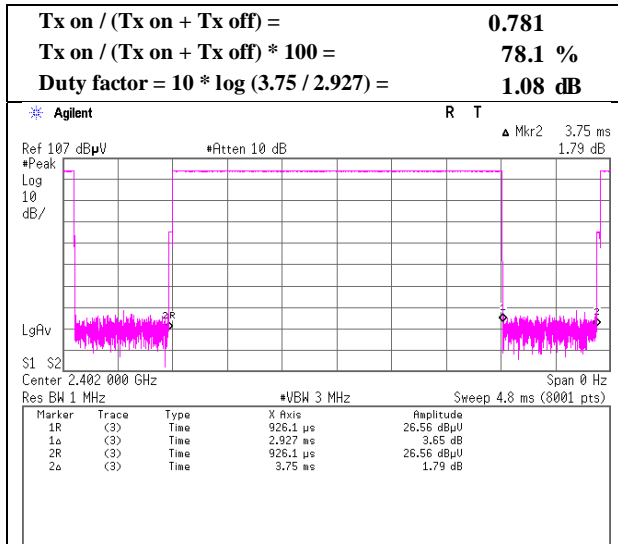

2DH5

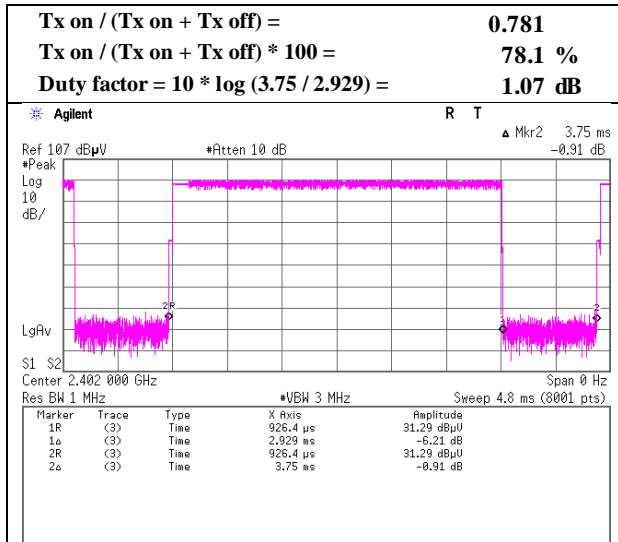

3DH5

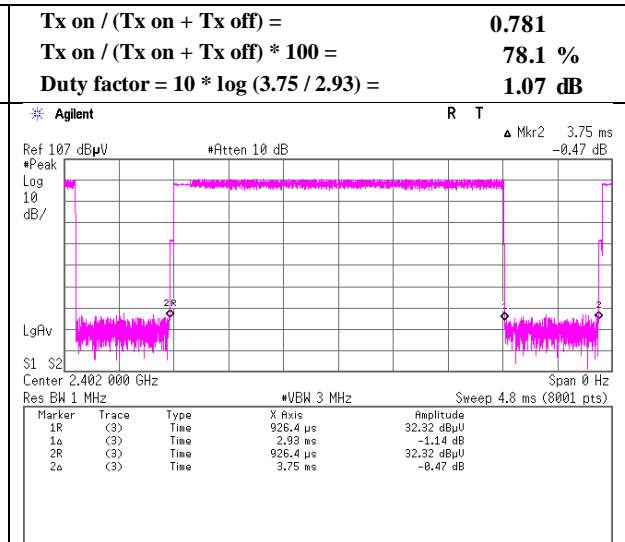

UL Japan, Inc.

Ise EMC Lab.

4383-326 Asama-cho, Ise-shi, Mie-ken 516-0021 JAPAN

Telephone : +81 596 24 8999

Facsimile : +81 596 24 8124

Radiated Spurious Emission

Test place : Ise EMC Lab. No.3 Semi Anechoic Chamber
Report No. : 11500829H
Date : December 19, 2016 December 21, 2016 December 21, 2016 December 22, 2016
Temperature / Humidity : 24 deg. C / 33 % RH 21 deg. C / 34 % RH 25deg. C / 33 % RH 23deg. C / 45 % RH
Engineer : Tomoki Matsui Ken Fujita Tomoki Matsui Tomoki Matsui
 (1 GHz -10 GHz) (10 GHz - 18 GHz) (18 GHz - 26.5 GHz) (Below 1 GHz)
Mode : Tx, Hopping Off, DH5 2402 MHz

Polarity	Frequency [MHz]	Detector	Reading [dBuV]	Ant.Fac. [dB/m]	Loss [dB]	Gain [dB]	Duty Factor [dB]	Result [dBuV/m]	Limit [dBuV/m]	Margin [dB]	Remark
Hori	32.940	QP	27.9	16.5	7.2	32.2	-	19.4	40.0	20.6	
Hori	52.740	QP	39.6	9.8	7.5	32.2	-	24.7	40.0	15.3	
Hori	168.000	QP	46.2	15.9	8.9	32.1	-	38.9	43.5	4.6	
Hori	180.000	QP	38.2	16.3	9.0	32.1	-	31.4	43.5	12.1	
Hori	192.000	QP	44.1	16.4	9.1	32.1	-	37.5	43.5	6.0	
Hori	196.600	QP	38.9	16.4	9.2	32.1	-	32.4	43.5	11.1	
Hori	1050.000	PK	56.7	23.7	5.7	35.2	-	50.9	73.9	23.0	
Hori	1150.000	PK	57.8	24.1	5.8	34.9	-	52.8	73.9	21.1	
Hori	1250.000	PK	54.9	24.4	5.9	34.6	-	50.6	73.9	23.3	
Hori	2390.000	PK	43.0	26.7	6.8	32.7	-	43.8	73.9	30.1	
Hori	4804.000	PK	39.8	31.0	9.0	31.8	-	48.0	73.9	25.9	Floor noise
Hori	7206.000	PK	40.0	35.7	10.3	32.6	-	53.4	73.9	20.5	Floor noise
Hori	9608.000	PK	39.6	37.2	10.9	33.2	-	54.5	73.9	19.4	Floor noise
Hori	1050.000	AV	54.8	23.7	5.7	35.2	-	49.0	53.9	4.9	
Hori	1150.000	AV	56.2	24.1	5.8	34.9	-	51.2	53.9	2.7	
Hori	1250.000	AV	53.0	24.4	5.9	34.6	-	48.7	53.9	5.2	
Hori	2390.000	AV	29.2	26.7	6.8	32.7	-	30.0	53.9	23.9	
Hori	4804.000	AV	26.4	31.0	9.0	31.8	-	34.6	53.9	19.3	Floor noise
Hori	7206.000	AV	27.1	35.7	10.3	32.6	-	40.5	53.9	13.4	Floor noise
Hori	9608.000	AV	27.5	37.2	10.9	33.2	-	42.4	53.9	11.5	Floor noise
Vert	39.350	QP	44.6	14.5	7.3	32.2	-	34.2	40.0	5.8	
Vert	45.020	QP	44.2	12.6	7.4	32.2	-	32.0	40.0	8.0	
Vert	48.002	QP	46.4	11.5	7.4	32.2	-	33.1	40.0	6.9	
Vert	158.000	QP	33.7	15.5	8.8	32.1	-	25.9	43.5	17.6	
Vert	168.000	QP	43.4	15.9	8.9	32.1	-	36.1	43.5	7.4	
Vert	196.600	QP	36.8	16.4	9.2	32.1	-	30.3	43.5	13.2	
Vert	1050.000	PK	55.1	23.7	5.7	35.2	-	49.3	73.9	24.6	
Vert	1150.000	PK	56.3	24.1	5.8	34.9	-	51.3	73.9	22.6	
Vert	1250.000	PK	56.3	24.4	5.9	34.6	-	52.0	73.9	21.9	
Vert	2390.000	PK	43.9	26.7	6.8	32.7	-	44.7	73.9	29.2	
Vert	4804.000	PK	39.7	31.0	9.0	31.8	-	47.9	73.9	26.0	Floor noise
Vert	7206.000	PK	40.0	35.7	10.3	32.6	-	53.4	73.9	20.5	Floor noise
Vert	9608.000	PK	39.6	37.2	10.9	33.2	-	54.5	73.9	19.4	Floor noise
Vert	1050.000	AV	52.3	23.7	5.7	35.2	-	46.5	53.9	7.4	
Vert	1150.000	AV	54.7	24.1	5.8	34.9	-	49.7	53.9	4.2	
Vert	1250.000	AV	54.4	24.4	5.9	34.6	-	50.1	53.9	3.8	
Vert	2390.000	AV	29.2	26.7	6.8	32.7	-	30.0	53.9	23.9	
Vert	4804.000	AV	26.4	31.0	9.0	31.8	-	34.6	53.9	19.3	Floor noise
Vert	7206.000	AV	27.1	35.7	10.3	32.6	-	40.5	53.9	13.4	Floor noise
Vert	9608.000	AV	27.5	37.2	10.9	33.2	-	42.4	53.9	11.5	Floor noise

Result = Reading + Ant Factor + Loss (Cable+Attenuator+Filter+Distance factor(above 1 GHz)) - Gain(Amplifier)

*Other frequency noises omitted in this report were not seen or had enough margin (more than 20 dB).

Distance factor: 1 GHz - 10 GHz 20log (4.45 m / 3.0 m) = 3.43 dB
 10 GHz - 26.5 GHz 20log (1.0 m / 3.0 m) = -9.5 dB

20dBc Data Sheet

Polarity	Frequency [MHz]	Detector	Reading [dBuV]	Ant Factor [dB/m]	Loss [dB]	Gain [dB]	Result [dBuV/m]	Limit [dBuV/m]	Margin [dB]	Remark
Hori	2402.000	PK	100.3	26.7	6.8	32.7	101.1	-	-	Carrier
Hori	2400.000	PK	41.2	26.7	6.8	32.7	42.0	81.1	39.1	
Vert	2402.000	PK	100.1	26.7	6.8	32.7	100.9	-	-	Carrier
Vert	2400.000	PK	42.8	26.7	6.8	32.7	43.6	80.9	37.3	

Result = Reading + Ant Factor + Loss (Cable+Attenuator+Filter+Distance factor(above 1 GHz)) - Gain(Amplifier)

***These results have sufficient margin without taking account Dwell time factor.**

UL Japan, Inc.

Ise EMC Lab.

4383-326 Asama-cho, Ise-shi, Mie-ken 516-0021 JAPAN

Telephone : +81 596 24 8999

Facsimile : +81 596 24 8124

Radiated Spurious Emission
(Reference Plot for band-edge)

Test place : Ise EMC Lab. No.3 Semi Anechoic Chamber
Report No. : 11500829H
Date : December 19, 2016
Temperature / Humidity : 24 deg. C / 33 % RH
Engineer : Tomoki Matsui
(1 GHz -10 GHz)
Mode : Tx, Hopping Off, DH5 2402 MHz

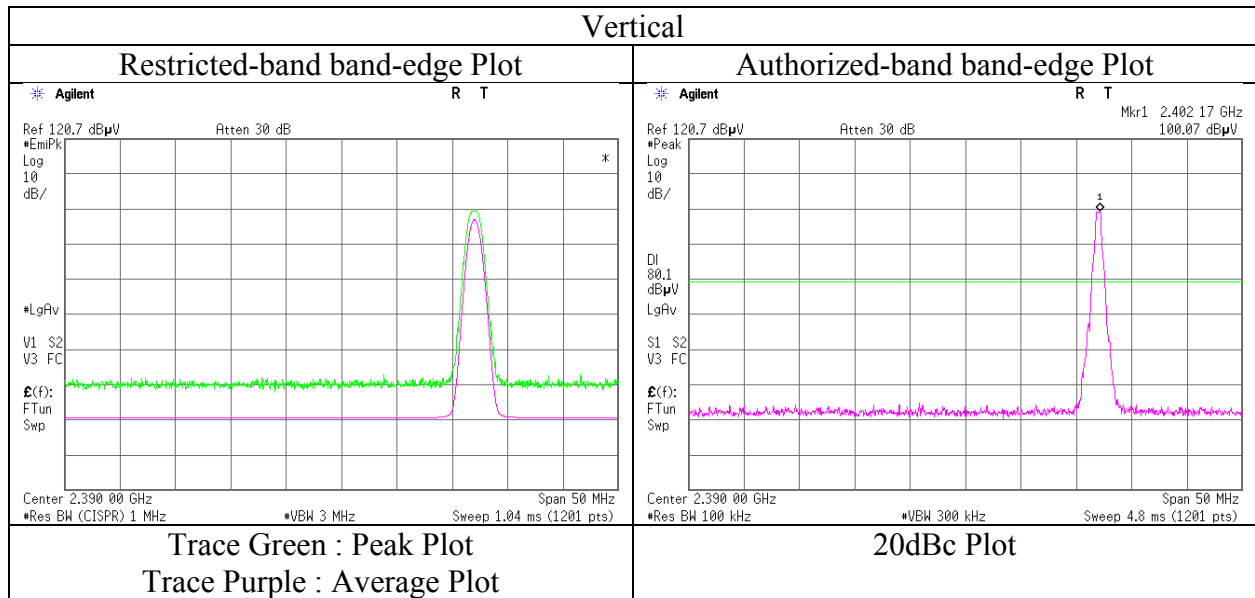
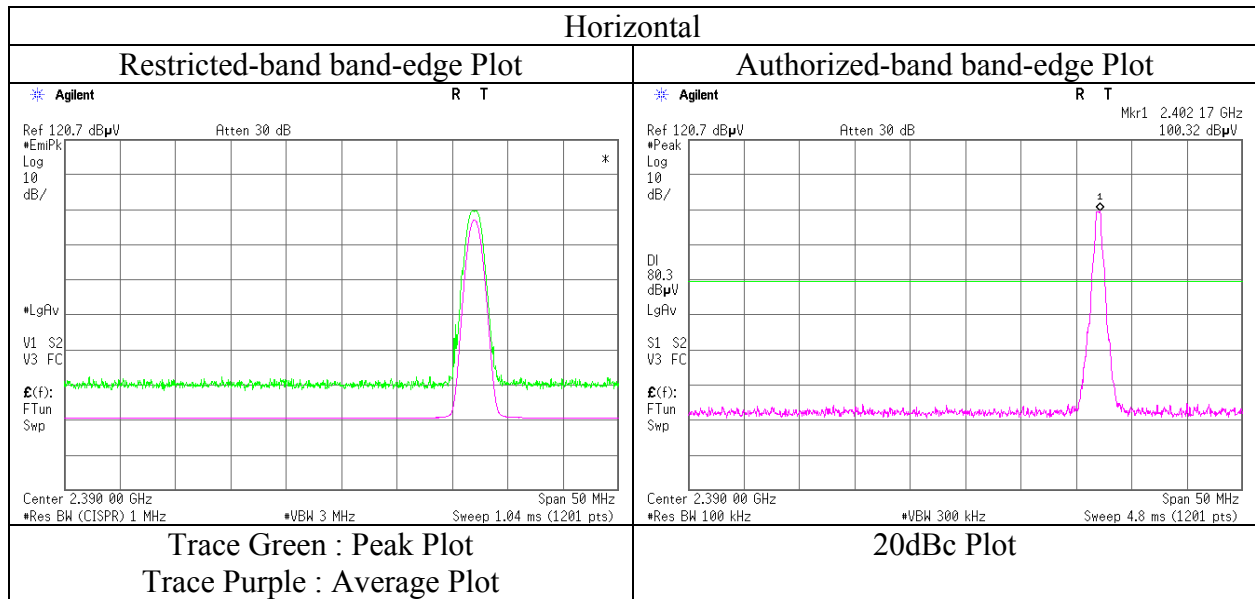

* Final result of restricted band edge was shown in tabular data.

Radiated Spurious Emission

Test place : Ise EMC Lab. No.3 Semi Anechoic Chamber
Report No. : 11500829H
Date : December 19, 2016 December 21, 2016 December 21, 2016 December 22, 2016
Temperature / Humidity : 24 deg. C / 33 % RH 21 deg. C / 34 % RH 25deg. C / 33 % RH 23deg. C / 45 % RH
Engineer : Tomoki Matsui Ken Fujita Tomoki Matsui Tomoki Matsui
 (1 GHz - 10 GHz) (10 GHz - 18 GHz) (18 GHz - 26.5 GHz) (Below 1 GHz)
Mode : Tx, Hopping Off, DH5 2441 MHz

Polarity	Frequency [MHz]	Detector	Reading [dBuV]	Ant.Fac. [dB/m]	Loss [dB]	Gain [dB]	Duty Factor [dB]	Result [dBuV/m]	Limit [dBuV/m]	Margin [dB]	Remark
Hori	32.940	QP	28.0	16.5	7.2	32.2	-	19.5	40.0	20.5	
Hori	52.740	QP	39.6	9.8	7.5	32.2	-	24.7	40.0	15.3	
Hori	168.000	QP	46.2	15.9	8.9	32.1	-	38.9	43.5	4.6	
Hori	180.000	QP	38.0	16.3	9.0	32.1	-	31.2	43.5	12.3	
Hori	192.000	QP	44.1	16.4	9.1	32.1	-	37.5	43.5	6.0	
Hori	196.600	QP	39.0	16.4	9.2	32.1	-	32.5	43.5	11.0	
Hori	1050.000	PK	57.3	23.7	5.7	35.2	-	51.5	73.9	22.4	
Hori	1150.000	PK	57.6	24.1	5.8	34.9	-	52.6	73.9	21.3	
Hori	1250.000	PK	54.5	24.4	5.9	34.6	-	50.2	73.9	23.7	
Hori	4882.000	PK	39.7	31.3	9.0	31.7	-	48.3	73.9	25.6	Floor noise
Hori	7323.000	PK	41.2	35.6	10.2	32.6	-	54.4	73.9	19.5	Floor noise
Hori	9764.000	PK	40.5	37.2	10.9	33.3	-	55.3	73.9	18.6	Floor noise
Hori	1050.000	AV	54.9	23.7	5.7	35.2	-	49.1	53.9	4.8	
Hori	1150.000	AV	56.1	24.1	5.8	34.9	-	51.1	53.9	2.8	
Hori	1250.000	AV	52.5	24.4	5.9	34.6	-	48.2	53.9	5.7	
Hori	4882.000	AV	27.5	31.3	9.0	31.7	-	36.1	53.9	17.8	Floor noise
Hori	7323.000	AV	29.0	35.6	10.2	32.6	-	42.2	53.9	11.7	Floor noise
Hori	9764.000	AV	27.7	37.2	10.9	33.3	-	42.5	53.9	11.4	Floor noise
Vert	39.350	QP	44.4	14.5	7.3	32.2	-	34.0	40.0	6.0	
Vert	45.020	QP	44.2	12.6	7.4	32.2	-	32.0	40.0	8.0	
Vert	48.002	QP	46.3	11.5	7.4	32.2	-	33.0	40.0	7.0	
Vert	158.000	QP	33.7	15.5	8.8	32.1	-	25.9	43.5	17.6	
Vert	168.000	QP	43.4	15.9	8.9	32.1	-	36.1	43.5	7.4	
Vert	196.600	QP	37.1	16.4	9.2	32.1	-	30.6	43.5	12.9	
Vert	1050.000	PK	55.8	23.7	5.7	35.2	-	50.0	73.9	23.9	
Vert	1150.000	PK	56.0	24.1	5.8	34.9	-	51.0	73.9	22.9	
Vert	1250.000	PK	55.1	24.4	5.9	34.6	-	50.8	73.9	23.1	
Vert	4882.000	PK	39.7	31.3	9.0	31.7	-	48.3	73.9	25.6	Floor noise
Vert	7323.000	PK	41.2	35.6	10.2	32.6	-	54.4	73.9	19.5	Floor noise
Vert	9764.000	PK	40.5	37.2	10.9	33.3	-	55.3	73.9	18.6	Floor noise
Vert	1050.000	AV	53.4	23.7	5.7	35.2	-	47.6	53.9	6.3	
Vert	1150.000	AV	54.3	24.1	5.8	34.9	-	49.3	53.9	4.6	
Vert	1250.000	AV	53.2	24.4	5.9	34.6	-	48.9	53.9	5.0	
Vert	4882.000	AV	27.5	31.3	9.0	31.7	-	36.1	53.9	17.8	Floor noise
Vert	7323.000	AV	29.0	35.6	10.2	32.6	-	42.2	53.9	11.7	Floor noise
Vert	9764.000	AV	27.7	37.2	10.9	33.3	-	42.5	53.9	11.4	Floor noise

Result = Reading + Ant Factor + Loss (Cable+Attenuator+Filter+Distance factor(above 1 GHz)) - Gain(Amplifier)

*Other frequency noises omitted in this report were not seen or had enough margin (more than 20 dB).

Distance factor: 1 GHz - 10 GHz 20log (4.45 m / 3.0 m) = 3.43 dB
 10 GHz - 26.5 GHz 20log (1.0 m / 3.0 m) = -9.5 dB

Radiated Spurious Emission

Test place : Ise EMC Lab. No.3 Semi Anechoic Chamber
Report No. : 11500829H
Date : December 19, 2016 December 21, 2016 December 21, 2016 December 22, 2016
Temperature / Humidity : 24 deg. C / 33 % RH 21 deg. C / 34 % RH 25deg. C / 33 % RH 23deg. C / 45 % RH
Engineer : Tomoki Matsui Ken Fujita Tomoki Matsui Tomoki Matsui
 (1 GHz -10 GHz) (10 GHz - 18 GHz) (18 GHz - 26.5 GHz) (Below 1 GHz)
Mode : Tx, Hopping Off, DH5 2480 MHz

Polarity	Frequency [MHz]	Detector	Reading [dBuV]	Ant.Fac. [dB/m]	Loss [dB]	Gain [dB]	Duty Factor [dB]	Result [dBuV/m]	Limit [dBuV/m]	Margin [dB]	Remark
Hori	32.940	QP	27.9	16.5	7.2	32.2	-	19.4	40.0	20.6	
Hori	52.740	QP	39.5	9.8	7.5	32.2	-	24.6	40.0	15.4	
Hori	168.000	QP	46.2	15.9	8.9	32.1	-	38.9	43.5	4.6	
Hori	180.000	QP	38.2	16.3	9.0	32.1	-	31.4	43.5	12.1	
Hori	192.000	QP	44.1	16.4	9.1	32.1	-	37.5	43.5	6.0	
Hori	196.600	QP	38.7	16.4	9.2	32.1	-	32.2	43.5	11.3	
Hori	1050.000	PK	57.1	23.7	5.7	35.2	-	51.3	73.9	22.6	
Hori	1150.000	PK	57.4	24.1	5.8	34.9	-	52.4	73.9	21.5	
Hori	1250.000	PK	54.5	24.4	5.9	34.6	-	50.2	73.9	23.7	
Hori	2483.500	PK	47.6	26.8	6.9	32.6	-	48.7	73.9	25.2	
Hori	4960.000	PK	39.8	31.5	9.0	31.7	-	48.6	73.9	25.3	Floor noise
Hori	7440.000	PK	41.0	35.5	10.3	32.7	-	54.1	73.9	19.8	Floor noise
Hori	9920.000	PK	41.3	37.2	11.0	33.4	-	56.1	73.9	17.8	Floor noise
Hori	1050.000	AV	54.6	23.7	5.7	35.2	-	48.8	53.9	5.1	
Hori	1150.000	AV	55.7	24.1	5.8	34.9	-	50.7	53.9	3.2	
Hori	1250.000	AV	52.5	24.4	5.9	34.6	-	48.2	53.9	5.7	
Hori	2483.500	AV	31.5	26.8	6.9	32.6	-	32.6	53.9	21.3	
Hori	4960.000	AV	26.6	31.5	9.0	31.7	-	35.4	53.9	18.5	Floor noise
Hori	7440.000	AV	27.7	35.5	10.3	32.7	-	40.8	53.9	13.1	Floor noise
Hori	9920.000	AV	27.7	37.2	11.0	33.4	-	42.5	53.9	11.4	Floor noise
Vert	39.350	QP	44.2	14.5	7.3	32.2	-	33.8	40.0	6.2	
Vert	45.020	QP	44.2	12.6	7.4	32.2	-	32.0	40.0	8.0	
Vert	48.002	QP	46.3	11.5	7.4	32.2	-	33.0	40.0	7.0	
Vert	158.000	QP	33.7	15.5	8.8	32.1	-	25.9	43.5	17.6	
Vert	168.000	QP	43.6	15.9	8.9	32.1	-	36.3	43.5	7.2	
Vert	196.600	QP	37.0	16.4	9.2	32.1	-	30.5	43.5	13.0	
Vert	1050.000	PK	55.0	23.7	5.7	35.2	-	49.2	73.9	24.7	
Vert	1150.000	PK	55.8	24.1	5.8	34.9	-	50.8	73.9	23.1	
Vert	1250.000	PK	54.8	24.4	5.9	34.6	-	50.5	73.9	23.4	
Vert	2483.500	PK	47.5	26.8	6.9	32.6	-	48.6	73.9	25.3	
Vert	4960.000	PK	39.8	31.5	9.0	31.7	-	48.6	73.9	25.3	Floor noise
Vert	7440.000	PK	41.0	35.5	10.3	32.7	-	54.1	73.9	19.8	Floor noise
Vert	9920.000	PK	41.3	37.2	11.0	33.4	-	56.1	73.9	17.8	Floor noise
Vert	1050.000	AV	52.4	23.7	5.7	35.2	-	46.6	53.9	7.3	
Vert	1150.000	AV	54.1	24.1	5.8	34.9	-	49.1	53.9	4.8	
Vert	1250.000	AV	53.0	24.4	5.9	34.6	-	48.7	53.9	5.2	
Vert	2483.500	AV	31.5	26.8	6.9	32.6	-	32.6	53.9	21.3	
Vert	4960.000	AV	26.6	31.5	9.0	31.7	-	35.4	53.9	18.5	Floor noise
Vert	7440.000	AV	27.7	35.5	10.3	32.7	-	40.8	53.9	13.1	Floor noise
Vert	9920.000	AV	27.7	37.2	11.0	33.4	-	42.5	53.9	11.4	Floor noise

Result = Reading + Ant Factor + Loss (Cable+Attenuator+Filter+Distance factor(above 1 GHz)) - Gain(Amplifier)

*Other frequency noises omitted in this report were not seen or had enough margin (more than 20 dB).

Distance factor: 1 GHz - 10 GHz 20log (4.45 m / 3.0 m) = 3.43 dB
 10 GHz - 26.5 GHz 20log (1.0 m / 3.0 m) = -9.5 dB

Radiated Spurious Emission
(Reference Plot for band-edge)

Test place : Ise EMC Lab. No.3 Semi Anechoic Chamber
Report No. : 11500829H
Date : December 19, 2016
Temperature / Humidity : 24 deg. C / 33 % RH
Engineer : Tomoki Matsui
(1 GHz -10 GHz)
Mode : Tx, Hopping Off, DH5 2480 MHz

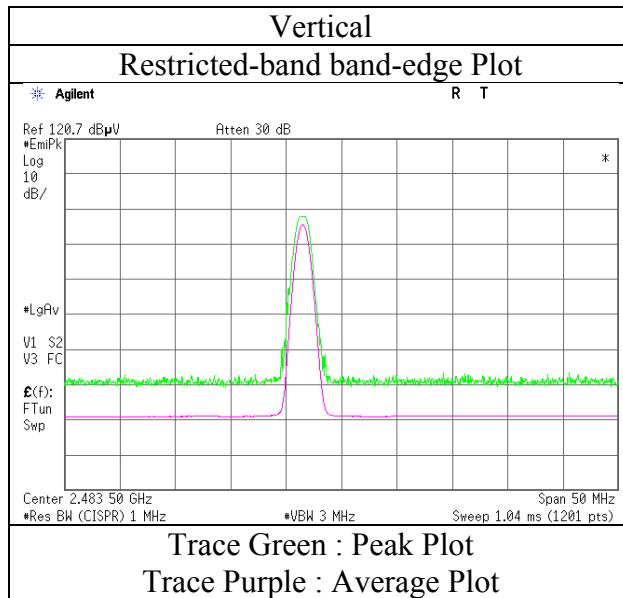
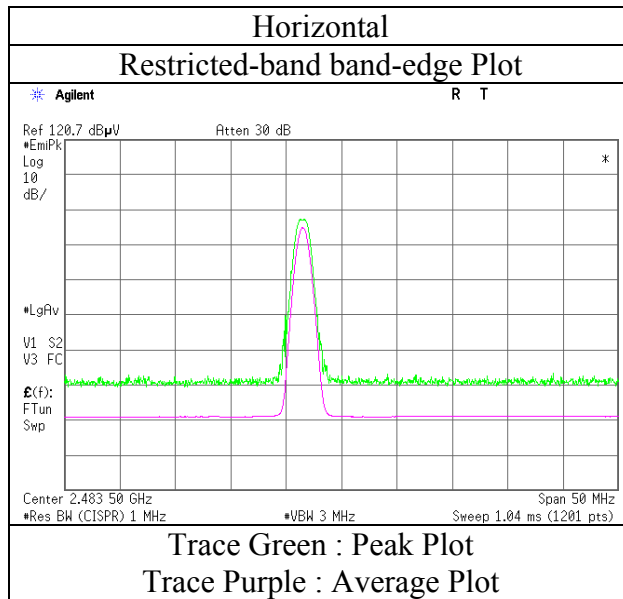

* Final result of restricted band edge was shown in tabular data.

Radiated Spurious Emission

Test place : Ise EMC Lab. No.3 Semi Anechoic Chamber
Report No. : 11500829H
Date : December 19, 2016 December 21, 2016 December 21, 2016 December 22, 2016
Temperature / Humidity : 24 deg. C / 33 % RH 21 deg. C / 34 % RH 25deg. C / 33 % RH 23deg. C / 45 % RH
Engineer : Tomoki Matsui Ken Fujita Tomoki Matsui Tomoki Matsui
 (1 GHz -10 GHz) (10 GHz - 18 GHz) (18 GHz - 26.5 GHz) (Below 1 GHz)
Mode : Tx, Hopping Off, 3DH5 2402 MHz

Polarity	Frequency [MHz]	Detector	Reading [dBuV]	Ant.Fac. [dB/m]	Loss [dB]	Gain [dB]	Duty Factor [dB]	Result [dBuV/m]	Limit [dBuV/m]	Margin [dB]	Remark
Hori	32.940	QP	28.1	16.5	7.2	32.2	-	19.6	40.0	20.4	
Hori	52.740	QP	39.6	9.8	7.5	32.2	-	24.7	40.0	15.3	
Hori	168.000	QP	46.2	15.9	8.9	32.1	-	38.9	43.5	4.6	
Hori	180.000	QP	38.0	16.3	9.0	32.1	-	31.2	43.5	12.3	
Hori	192.000	QP	44.1	16.4	9.1	32.1	-	37.5	43.5	6.0	
Hori	196.600	QP	38.7	16.4	9.2	32.1	-	32.2	43.5	11.3	
Hori	1050.000	PK	55.5	23.7	5.7	35.2	-	49.7	73.9	24.2	
Hori	1150.000	PK	56.8	24.1	5.8	34.9	-	51.8	73.9	22.1	
Hori	1250.000	PK	54.5	24.4	5.9	34.6	-	50.2	73.9	23.7	
Hori	2390.000	PK	43.2	26.7	6.8	32.7	-	44.0	73.9	29.9	
Hori	4804.000	PK	39.8	31.0	9.0	31.8	-	48.0	73.9	25.9	Floor noise
Hori	7206.000	PK	40.0	35.7	10.3	32.6	-	53.4	73.9	20.5	Floor noise
Hori	9608.000	PK	39.6	37.2	10.9	33.2	-	54.5	73.9	19.4	Floor noise
Hori	1050.000	AV	53.3	23.7	5.7	35.2	-	47.5	53.9	6.4	
Hori	1150.000	AV	55.0	24.1	5.8	34.9	-	50.0	53.9	3.9	
Hori	1250.000	AV	52.4	24.4	5.9	34.6	-	48.1	53.9	5.8	
Hori	2390.000	AV	29.1	26.7	6.8	32.7	-	29.9	53.9	24.0	
Hori	4804.000	AV	26.4	31.0	9.0	31.8	-	34.6	53.9	19.3	Floor noise
Hori	7206.000	AV	27.1	35.7	10.3	32.6	-	40.5	53.9	13.4	Floor noise
Hori	9608.000	AV	27.5	37.2	10.9	33.2	-	42.4	53.9	11.5	Floor noise
Vert	39.350	QP	44.1	14.5	7.3	32.2	-	33.7	40.0	6.3	
Vert	45.020	QP	44.2	12.6	7.4	32.2	-	32.0	40.0	8.0	
Vert	48.002	QP	46.3	11.5	7.4	32.2	-	33.0	40.0	7.0	
Vert	158.000	QP	33.9	15.5	8.8	32.1	-	26.1	43.5	17.4	
Vert	168.000	QP	43.2	15.9	8.9	32.1	-	35.9	43.5	7.6	
Vert	196.600	QP	37.0	16.4	9.2	32.1	-	30.5	43.5	13.0	
Vert	1050.000	PK	54.1	23.7	5.7	35.2	-	48.3	73.9	25.6	
Vert	1150.000	PK	57.8	24.1	5.8	34.9	-	52.8	73.9	21.1	
Vert	1250.000	PK	53.2	24.4	5.9	34.6	-	48.9	73.9	25.0	
Vert	2390.000	PK	41.9	26.7	6.8	32.7	-	42.7	73.9	31.2	
Vert	4804.000	PK	39.7	31.0	9.0	31.8	-	47.9	73.9	26.0	Floor noise
Vert	7206.000	PK	40.0	35.7	10.3	32.6	-	53.4	73.9	20.5	Floor noise
Vert	9608.000	PK	39.6	37.2	10.9	33.2	-	54.5	73.9	19.4	Floor noise
Vert	1050.000	AV	50.8	23.7	5.7	35.2	-	45.0	53.9	8.9	
Vert	1150.000	AV	56.0	24.1	5.8	34.9	-	51.0	53.9	2.9	
Vert	1250.000	AV	50.7	24.4	5.9	34.6	-	46.4	53.9	7.5	
Vert	2390.000	AV	29.1	26.7	6.8	32.7	-	29.9	53.9	24.0	
Vert	4804.000	AV	26.4	31.0	9.0	31.8	-	34.6	53.9	19.3	Floor noise
Vert	7206.000	AV	27.1	35.7	10.3	32.6	-	40.5	53.9	13.4	Floor noise
Vert	9608.000	AV	27.5	37.2	10.9	33.2	-	42.4	53.9	11.5	Floor noise

Result = Reading + Ant Factor + Loss (Cable+Attenuator+Filter+Distance factor(above 1 GHz)) - Gain(Amplifier)

*Other frequency noises omitted in this report were not seen or had enough margin (more than 20 dB).

Distance factor: 1 GHz - 10 GHz 20log (4.45 m / 3.0 m) = 3.43 dB
 10 GHz - 26.5 GHz 20log (1.0 m / 3.0 m) = -9.5 dB

20dBc Data Sheet

Polarity	Frequency [MHz]	Detector	Reading [dBuV]	Ant Factor [dB/m]	Loss [dB]	Gain [dB]	Result [dBuV/m]	Limit [dBuV/m]	Margin [dB]	Remark
Hori	2402.000	PK	93.8	26.7	6.8	32.7	94.6	-	-	Carrier
Hori	2400.000	PK	39.6	26.7	6.8	32.7	40.4	74.6	34.2	
Vert	2402.000	PK	94.3	26.7	6.8	32.7	95.1	-	-	Carrier
Vert	2400.000	PK	39.0	26.7	6.8	32.7	39.8	75.1	35.3	

Result = Reading + Ant Factor + Loss (Cable+Attenuator+Filter+Distance factor(above 1 GHz)) - Gain(Amplifier)

UL Japan, Inc.

Ise EMC Lab.

4383-326 Asama-cho, Ise-shi, Mie-ken 516-0021 JAPAN

Telephone : +81 596 24 8999

Facsimile : +81 596 24 8124

Radiated Spurious Emission (Reference Plot for band-edge)

Test place	Ise EMC Lab. No.3 Semi Anechoic Chamber
Report No.	11500829H
Date	December 19, 2016
Temperature / Humidity	24 deg. C / 33 % RH
Engineer	Tomoki Matsui
	(1 GHz -10 GHz)
Mode	Tx, Hopping Off, 3DH5 2402 MHz

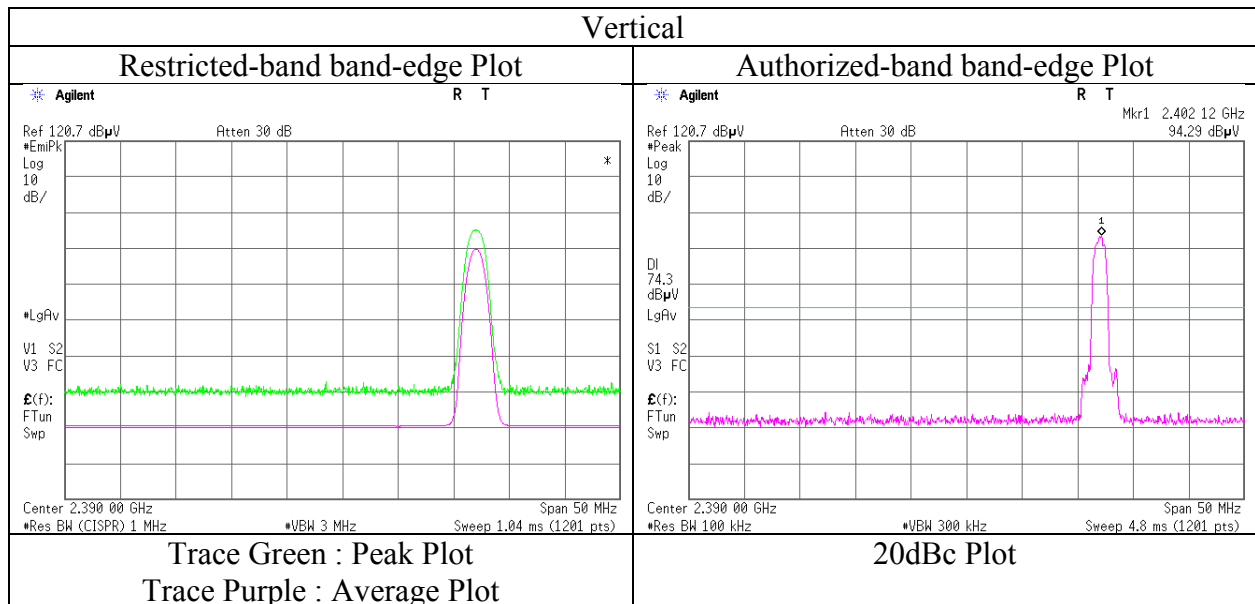
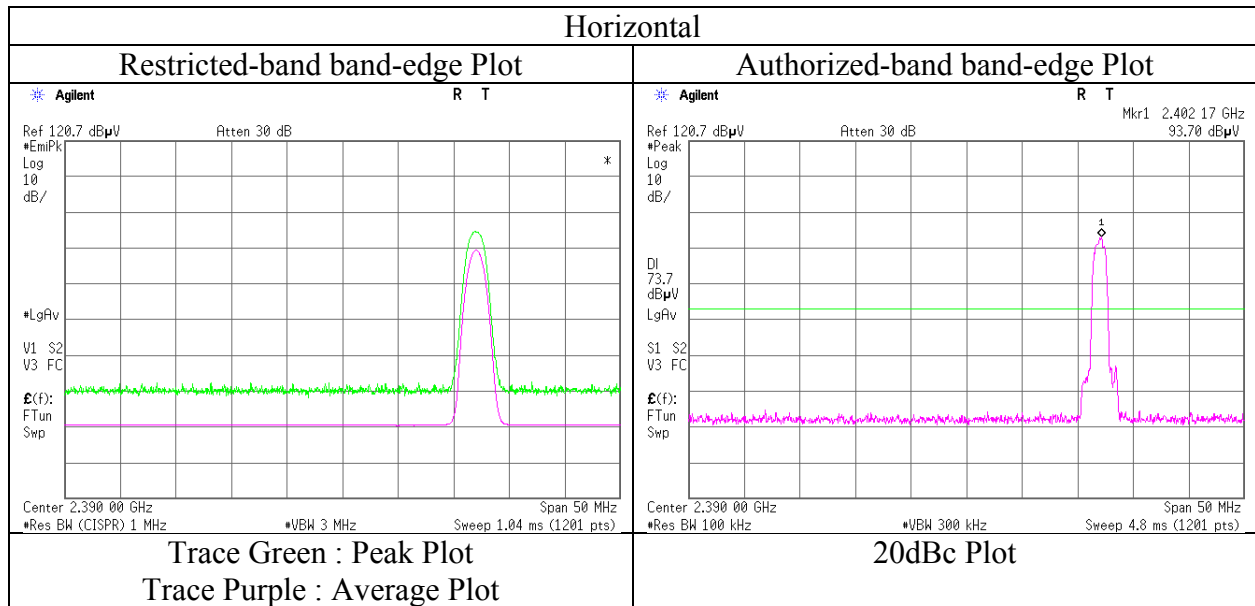

* Final result of restricted band edge was shown in tabular data.

UL Japan, Inc.

Ise EMC Lab.

4383-326 Asama-cho, Ise-shi, Mie-ken 516-0021 JAPAN

Telephone : +81 596 24 8999

Facsimile : +81 596 24 8124

Radiated Spurious Emission

Test place : Ise EMC Lab. No.3 Semi Anechoic Chamber
Report No. : 11500829H
Date : December 19, 2016 December 21, 2016 December 21, 2016 December 22, 2016
Temperature / Humidity : 24 deg. C / 33 % RH 21 deg. C / 34 % RH 25deg. C / 33 % RH 23deg. C / 45 % RH
Engineer : Tomoki Matsui Ken Fujita Tomoki Matsui Tomoki Matsui
 (1 GHz - 10 GHz) (10 GHz - 18 GHz) (18 GHz - 26.5 GHz) (Below 1 GHz)
Mode : Tx, Hopping Off, 3DH5 2441 MHz

Polarity	Frequency [MHz]	Detector	Reading [dBuV]	Ant.Fac. [dB/m]	Loss [dB]	Gain [dB]	Duty Factor [dB]	Result [dBuV/m]	Limit [dBuV/m]	Margin [dB]	Remark
Hori	32.940	QP	28.1	16.5	7.2	32.2	-	19.6	40.0	20.4	
Hori	52.740	QP	39.6	9.8	7.5	32.2	-	24.7	40.0	15.3	
Hori	168.000	QP	46.2	15.9	8.9	32.1	-	38.9	43.5	4.6	
Hori	180.000	QP	38.0	16.3	9.0	32.1	-	31.2	43.5	12.3	
Hori	192.000	QP	44.1	16.4	9.1	32.1	-	37.5	43.5	6.0	
Hori	196.600	QP	38.7	16.4	9.2	32.1	-	32.2	43.5	11.3	
Hori	1050.000	PK	56.2	23.7	5.7	35.2	-	50.4	73.9	23.5	
Hori	1150.000	PK	56.4	24.1	5.8	34.9	-	51.4	73.9	22.5	
Hori	1250.000	PK	54.1	24.4	5.9	34.6	-	49.8	73.9	24.1	
Hori	4882.000	PK	39.7	31.3	9.0	31.7	-	48.3	73.9	25.6	Floor noise
Hori	7323.000	PK	41.2	35.6	10.2	32.6	-	54.4	73.9	19.5	Floor noise
Hori	9764.000	PK	40.5	37.2	10.9	33.3	-	55.3	73.9	18.6	Floor noise
Hori	1050.000	AV	53.4	23.7	5.7	35.2	-	47.6	53.9	6.3	
Hori	1150.000	AV	54.8	24.1	5.8	34.9	-	49.8	53.9	4.1	
Hori	1250.000	AV	51.7	24.4	5.9	34.6	-	47.4	53.9	6.5	
Hori	4882.000	AV	27.5	31.3	9.0	31.7	-	36.1	53.9	17.8	Floor noise
Hori	7323.000	AV	29.0	35.6	10.2	32.6	-	42.2	53.9	11.7	Floor noise
Hori	9764.000	AV	27.7	37.2	10.9	33.3	-	42.5	53.9	11.4	Floor noise
Vert	39.350	QP	44.1	14.5	7.3	32.2	-	33.7	40.0	6.3	
Vert	45.020	QP	44.2	12.6	7.4	32.2	-	32.0	40.0	8.0	
Vert	48.002	QP	46.4	11.5	7.4	32.2	-	33.1	40.0	6.9	
Vert	158.000	QP	34.0	15.5	8.8	32.1	-	26.2	43.5	17.3	
Vert	168.000	QP	43.2	15.9	8.9	32.1	-	35.9	43.5	7.6	
Vert	196.600	QP	37.0	16.4	9.2	32.1	-	30.5	43.5	13.0	
Vert	1050.000	PK	54.2	23.7	5.7	35.2	-	48.4	73.9	25.5	
Vert	1150.000	PK	57.5	24.1	5.8	34.9	-	52.5	73.9	21.4	
Vert	1250.000	PK	54.8	24.4	5.9	34.6	-	50.5	73.9	23.4	
Vert	4882.000	PK	39.7	31.3	9.0	31.7	-	48.3	73.9	25.6	Floor noise
Vert	7323.000	PK	41.2	35.6	10.2	32.6	-	54.4	73.9	19.5	Floor noise
Vert	9764.000	PK	40.5	37.2	10.9	33.3	-	55.3	73.9	18.6	Floor noise
Vert	1050.000	AV	51.3	23.7	5.7	35.2	-	45.5	53.9	8.4	
Vert	1150.000	AV	56.0	24.1	5.8	34.9	-	51.0	53.9	2.9	
Vert	1250.000	AV	52.6	24.4	5.9	34.6	-	48.3	53.9	5.6	
Vert	4882.000	AV	27.5	31.3	9.0	31.7	-	36.1	53.9	17.8	Floor noise
Vert	7323.000	AV	29.0	35.6	10.2	32.6	-	42.2	53.9	11.7	Floor noise
Vert	9764.000	AV	27.7	37.2	10.9	33.3	-	42.5	53.9	11.4	Floor noise

Result = Reading + Ant Factor + Loss (Cable+Attenuator+Filter+Distance factor(above 1 GHz)) - Gain(Amplifier)

*Other frequency noises omitted in this report were not seen or had enough margin (more than 20 dB).

Distance factor: 1 GHz - 10 GHz 20log (4.45 m / 3.0 m) = 3.43 dB
 10 GHz - 26.5 GHz 20log (1.0 m / 3.0 m) = -9.5 dB

Radiated Spurious Emission

Test place : Ise EMC Lab. No.3 Semi Anechoic Chamber
Report No. : 11500829H
Date : December 19, 2016 December 21, 2016 December 21, 2016 December 22, 2016
Temperature / Humidity : 24 deg. C / 33 % RH 21 deg. C / 34 % RH 25deg. C / 33 % RH 23deg. C / 45 % RH
Engineer : Tomoki Matsui Ken Fujita Tomoki Matsui Tomoki Matsui
 (1 GHz - 10 GHz) (10 GHz - 18 GHz) (18 GHz - 26.5 GHz) (Below 1 GHz)
Mode : Tx, Hopping Off, 3DH5 2480 MHz

Polarity	Frequency [MHz]	Detector	Reading [dBuV]	Ant.Fac. [dB/m]	Loss [dB]	Gain [dB]	Duty Factor [dB]	Result [dBuV/m]	Limit [dBuV/m]	Margin [dB]	Remark
Hori	32.940	QP	27.9	16.5	7.2	32.2	-	19.4	40.0	20.6	
Hori	52.740	QP	39.6	9.8	7.5	32.2	-	24.7	40.0	15.3	
Hori	168.000	QP	46.2	15.9	8.9	32.1	-	38.9	43.5	4.6	
Hori	180.000	QP	38.0	16.3	9.0	32.1	-	31.2	43.5	12.3	
Hori	192.000	QP	43.6	16.4	9.1	32.1	-	37.0	43.5	6.5	
Hori	196.600	QP	38.7	16.4	9.2	32.1	-	32.2	43.5	11.3	
Hori	1050.000	PK	54.6	23.7	5.7	35.2	-	48.8	73.9	25.1	
Hori	1150.000	PK	56.0	24.1	5.8	34.9	-	51.0	73.9	22.9	
Hori	1250.000	PK	54.1	24.4	5.9	34.6	-	49.8	73.9	24.1	
Hori	2483.500	PK	45.9	26.8	6.9	32.6	-	47.0	73.9	26.9	
Hori	4960.000	PK	39.8	31.5	9.0	31.7	-	48.6	73.9	25.3	Floor noise
Hori	7440.000	PK	41.0	35.5	10.3	32.7	-	54.1	73.9	19.8	Floor noise
Hori	9920.000	PK	41.3	37.2	11.0	33.4	-	56.1	73.9	17.8	Floor noise
Hori	1050.000	AV	52.1	23.7	5.7	35.2	-	46.3	53.9	7.6	
Hori	1150.000	AV	54.0	24.1	5.8	34.9	-	49.0	53.9	4.9	
Hori	1250.000	AV	52.2	24.4	5.9	34.6	-	47.9	53.9	6.0	
Hori	2483.500	AV	30.0	26.8	6.9	32.6	-	31.1	53.9	22.8	
Hori	4960.000	AV	26.6	31.5	9.0	31.7	-	35.4	53.9	18.5	Floor noise
Hori	7440.000	AV	27.7	35.5	10.3	32.7	-	40.8	53.9	13.1	Floor noise
Hori	9920.000	AV	27.7	37.2	11.0	33.4	-	42.5	53.9	11.4	Floor noise
Vert	39.350	QP	44.1	14.5	7.3	32.2	-	33.7	40.0	6.3	
Vert	45.020	QP	44.2	12.6	7.4	32.2	-	32.0	40.0	8.0	
Vert	48.002	QP	46.4	11.5	7.4	32.2	-	33.1	40.0	6.9	
Vert	158.000	QP	34.0	15.5	8.8	32.1	-	26.2	43.5	17.3	
Vert	168.000	QP	43.2	15.9	8.9	32.1	-	35.9	43.5	7.6	
Vert	196.600	QP	36.7	16.4	9.2	32.1	-	30.2	43.5	13.3	
Vert	1050.000	PK	54.2	23.7	5.7	35.2	-	48.4	73.9	25.5	
Vert	1150.000	PK	58.0	24.1	5.8	34.9	-	53.0	73.9	20.9	
Vert	1250.000	PK	53.5	24.4	5.9	34.6	-	49.2	73.9	24.7	
Vert	2483.500	PK	45.4	26.8	6.9	32.6	-	46.5	73.9	27.4	
Vert	4960.000	PK	39.8	31.5	9.0	31.7	-	48.6	73.9	25.3	Floor noise
Vert	7440.000	PK	41.0	35.5	10.3	32.7	-	54.1	73.9	19.8	Floor noise
Vert	9920.000	PK	41.3	37.2	11.0	33.4	-	56.1	73.9	17.8	Floor noise
Vert	1050.000	AV	51.3	23.7	5.7	35.2	-	45.5	53.9	8.4	
Vert	1150.000	AV	56.3	24.1	5.8	34.9	-	51.3	53.9	2.6	
Vert	1250.000	AV	50.9	24.4	5.9	34.6	-	46.6	53.9	7.3	
Vert	2483.500	AV	29.9	26.8	6.9	32.6	-	31.0	53.9	22.9	
Vert	4960.000	AV	26.6	31.5	9.0	31.7	-	35.4	53.9	18.5	Floor noise
Vert	7440.000	AV	27.7	35.5	10.3	32.7	-	40.8	53.9	13.1	Floor noise
Vert	9920.000	AV	27.7	37.2	11.0	33.4	-	42.5	53.9	11.4	Floor noise

Result = Reading + Ant Factor + Loss (Cable+Attenuator+Filter+Distance factor(above 1 GHz)) - Gain(Amplifier)

*Other frequency noises omitted in this report were not seen or had enough margin (more than 20 dB).

Distance factor: 1 GHz - 10 GHz 20log (4.45 m / 3.0 m) = 3.43 dB
 10 GHz - 26.5 GHz 20log (1.0 m / 3.0 m) = -9.5 dB

Radiated Spurious Emission
(Reference Plot for band-edge)

Test place : Ise EMC Lab. No.3 Semi Anechoic Chamber
Report No. : 11500829H
Date : December 19, 2016
Temperature / Humidity : 24 deg. C / 33 % RH
Engineer : Tomoki Matsui
(1 GHz -10 GHz)
Mode : Tx, Hopping Off, 3DH5 2480 MHz

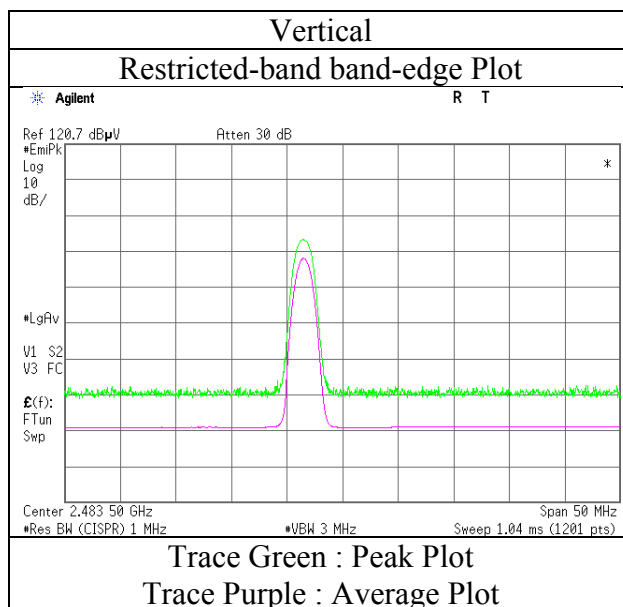
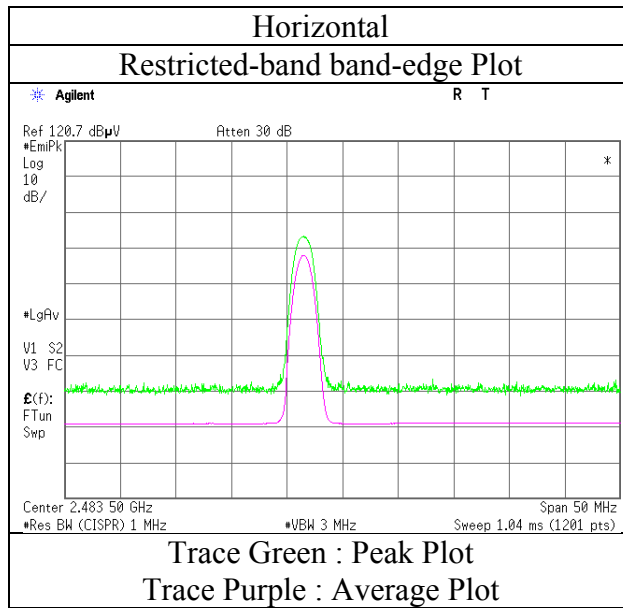

* Final result of restricted band edge was shown in tabular data.

Radiated Spurious Emission
(Plot data, Worst case)

Test place	Ise EMC Lab. No.3 Semi Anechoic Chamber			
Report No.	11500829H			
Date	December 19, 2016	December 21, 2016	December 21, 2016	December 22, 2016
Temperature / Humidity	24 deg. C / 33 % RH	21 deg. C / 34 % RH	25deg. C / 33 % RH	23deg. C / 45 % RH
Engineer	Tomoki Matsui	Ken Fujita	Tomoki Matsui	Tomoki Matsui
	(1 GHz -10 GHz)	(10 GHz - 18 GHz)	(18 GHz - 26.5 GHz)	(Below 1 GHz)
Mode	Tx, Hopping Off, DH5 2402 MHz			

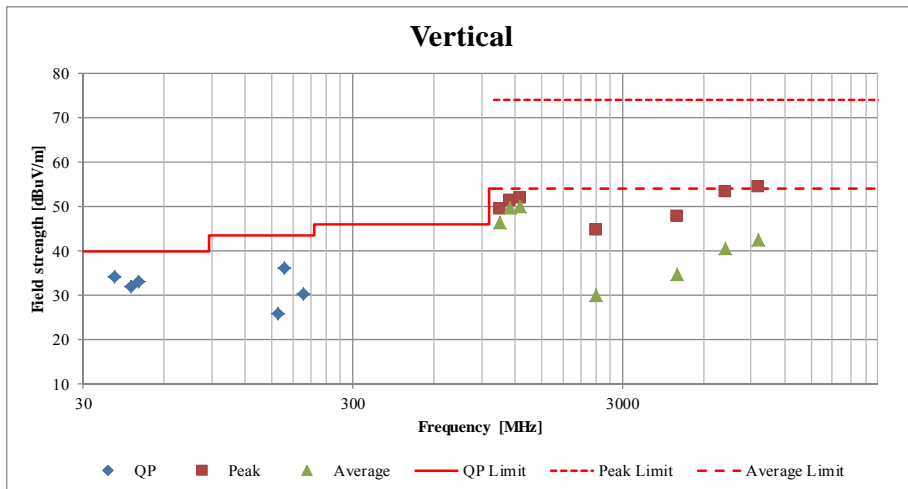
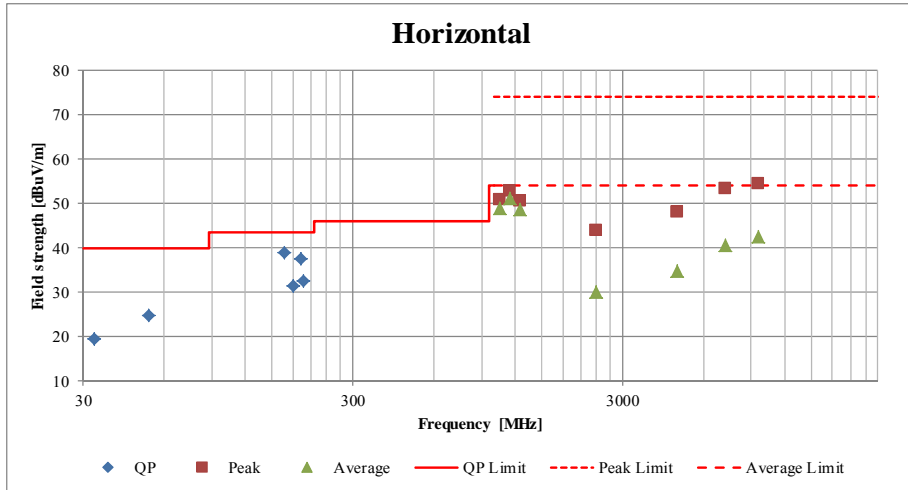

*These plots data contains sufficient number to show the trend of characteristic features for EUT.

Conducted Spurious Emission

Test place	Ise EMC Lab. No.6 Measurement Room
Report No.	11500829H
Date	December 12, 2016
Temperature / Humidity	26 deg. C / 23 % RH
Engineer	Yutaka Yoshida
Mode	Tx, Hopping Off, DH5

2402 MHz

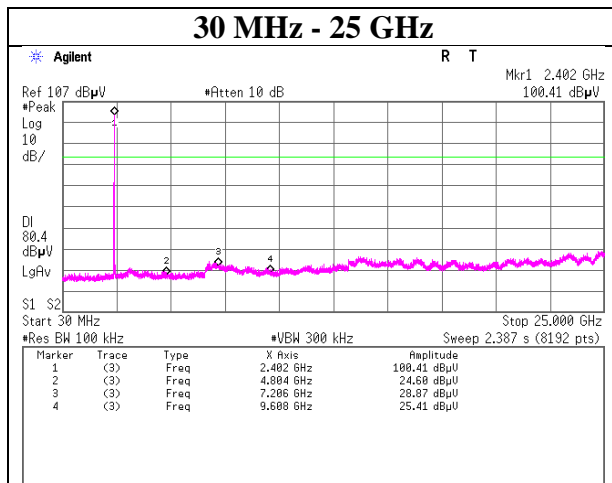
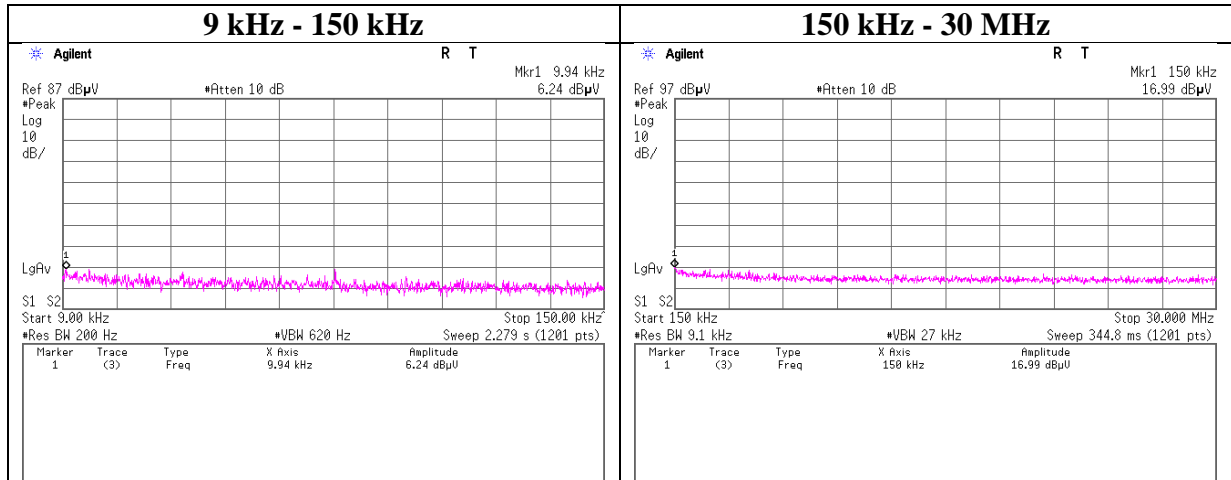

Conducted Spurious Emission

Test place	Ise EMC Lab. No.6 Measurement Room
Report No.	11500829H
Date	December 12, 2016
Temperature / Humidity	26 deg. C / 23 % RH
Engineer	Yutaka Yoshida
Mode	Tx, Hopping Off, DH5

2441 MHz

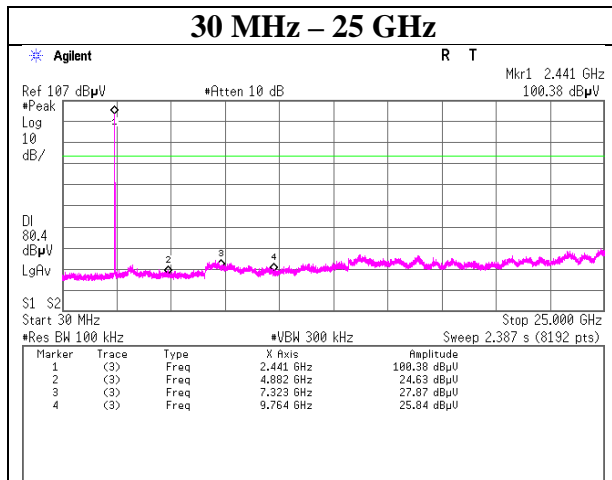
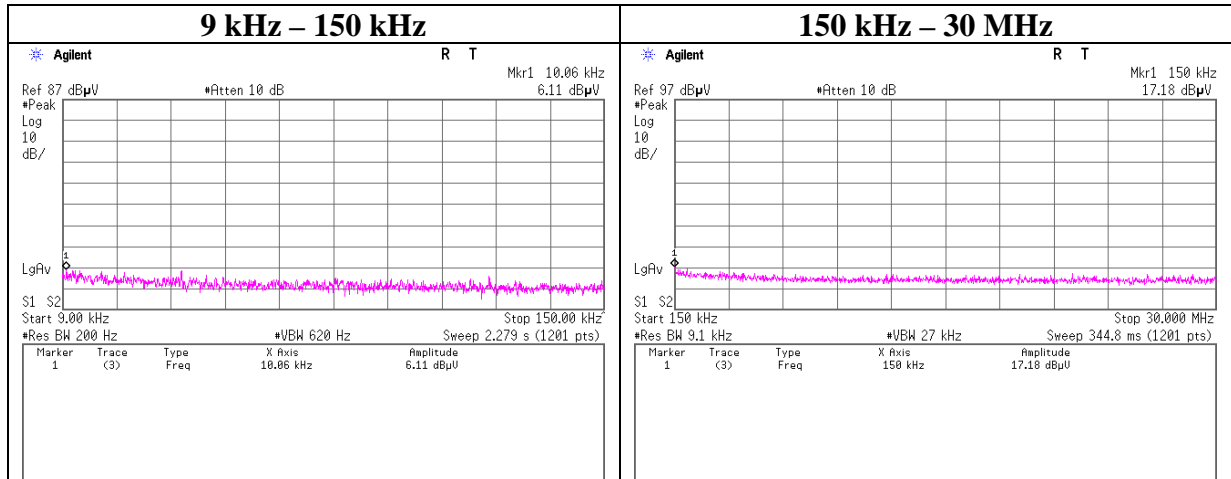

UL Japan, Inc.

Ise EMC Lab.

4383-326 Asama-cho, Ise-shi, Mie-ken 516-0021 JAPAN

Telephone : +81 596 24 8999

Facsimile : +81 596 24 8124

Conducted Spurious Emission

Test place	Ise EMC Lab. No.6 Measurement Room
Report No.	11500829H
Date	December 12, 2016
Temperature / Humidity	26 deg. C / 23 % RH
Engineer	Yutaka Yoshida
Mode	Tx, Hopping Off, DH5

2480 MHz

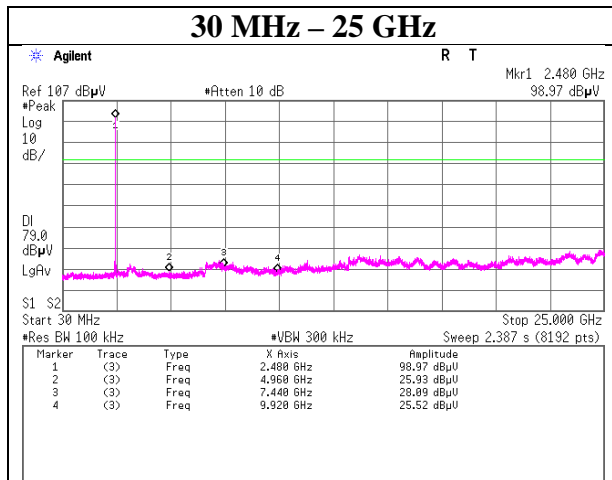
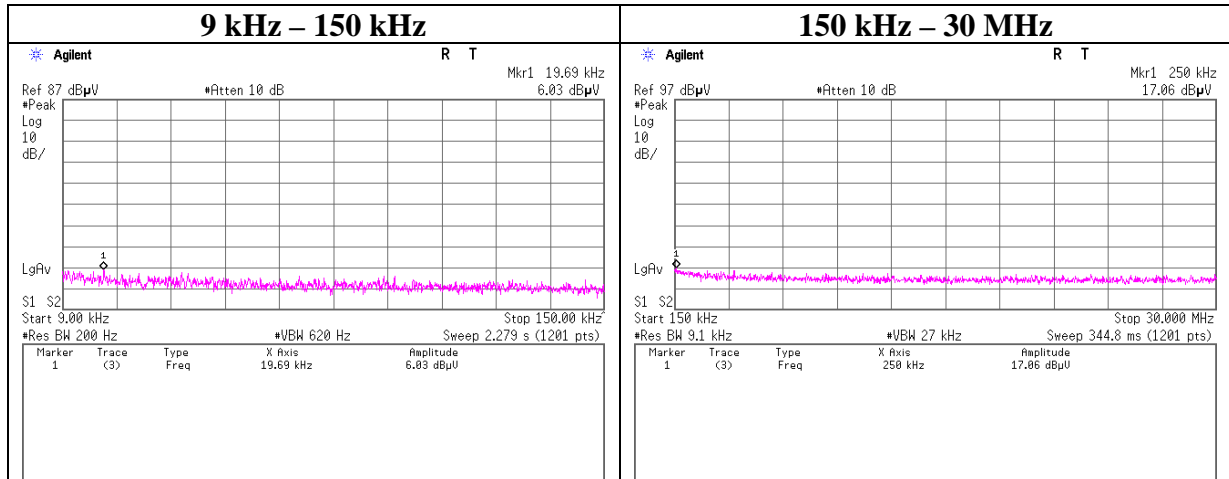

UL Japan, Inc.

Ise EMC Lab.

4383-326 Asama-cho, Ise-shi, Mie-ken 516-0021 JAPAN

Telephone : +81 596 24 8999

Facsimile : +81 596 24 8124

Conducted Spurious Emission

Test place	Ise EMC Lab. No.6 Measurement Room
Report No.	11500829H
Date	December 12, 2016
Temperature / Humidity	26 deg. C / 23 % RH
Engineer	Yutaka Yoshida
Mode	Tx, Hopping Off, 3DH5

2402 MHz

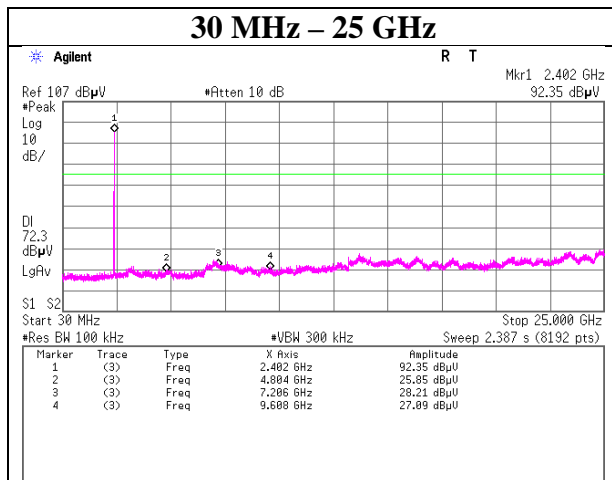
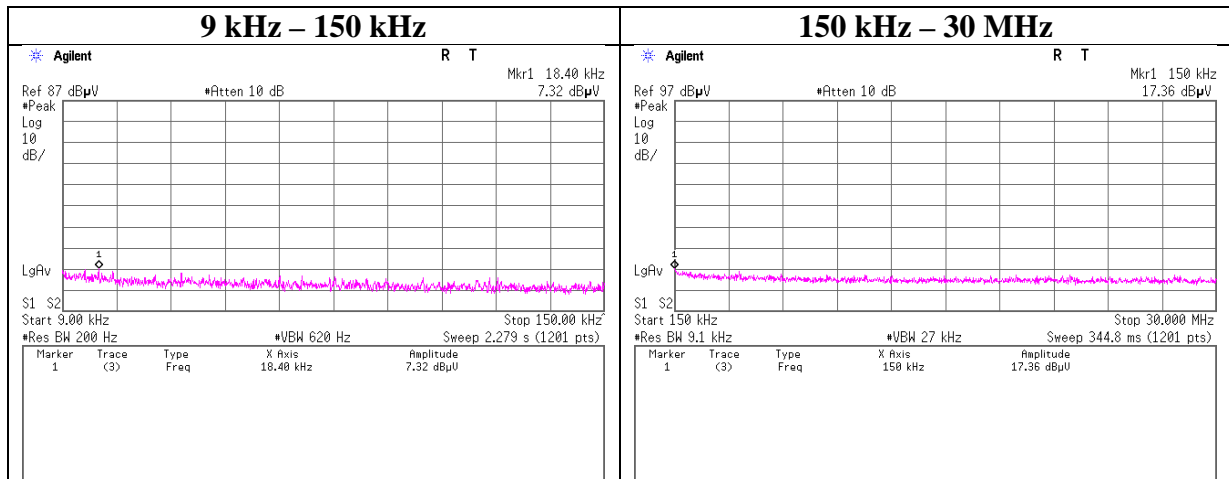

Conducted Spurious Emission

Test place	Ise EMC Lab. No.6 Measurement Room
Report No.	11500829H
Date	December 12, 2016
Temperature / Humidity	26 deg. C / 23 % RH
Engineer	Yutaka Yoshida
Mode	Tx, Hopping Off, 3DH5

2441 MHz

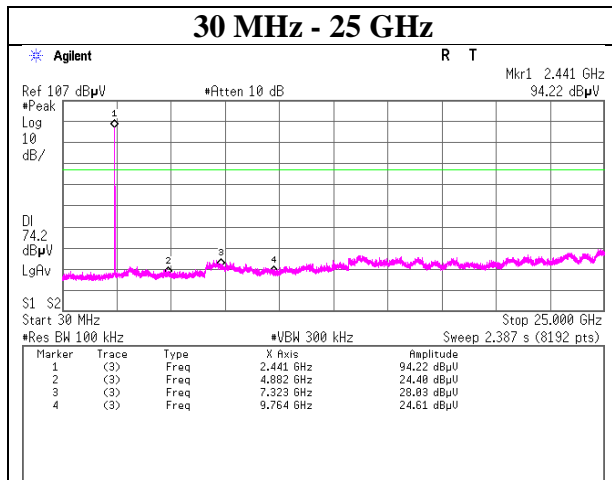
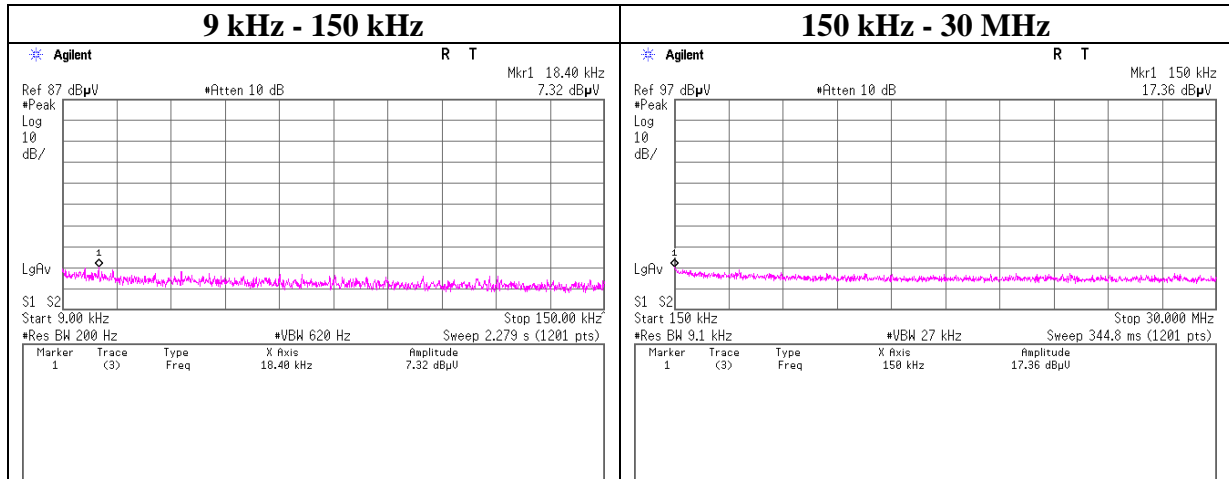

UL Japan, Inc.

Ise EMC Lab.

4383-326 Asama-cho, Ise-shi, Mie-ken 516-0021 JAPAN

Telephone : +81 596 24 8999

Facsimile : +81 596 24 8124

Conducted Spurious Emission

Test place	Ise EMC Lab. No.6 Measurement Room
Report No.	11500829H
Date	December 12, 2016
Temperature / Humidity	26 deg. C / 23 % RH
Engineer	Yutaka Yoshida
Mode	Tx, Hopping Off, 3DH5

2480 MHz

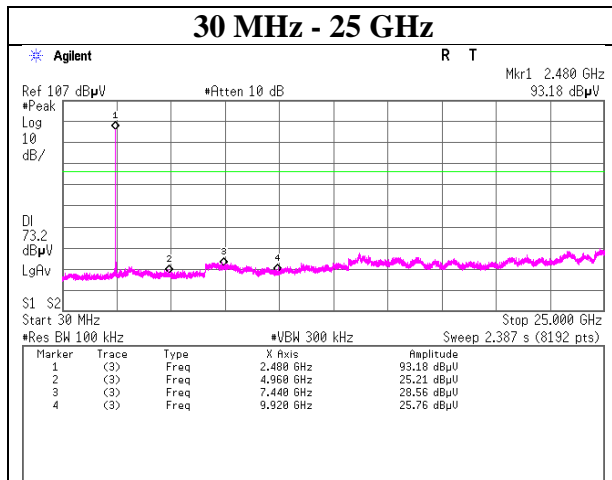
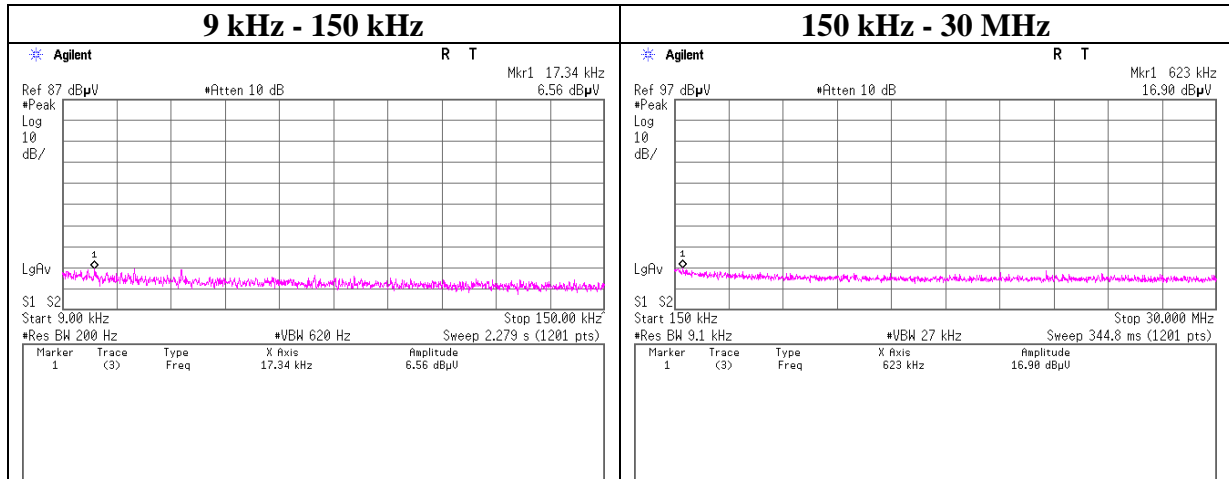

UL Japan, Inc.

Ise EMC Lab.

4383-326 Asama-cho, Ise-shi, Mie-ken 516-0021 JAPAN

Telephone : +81 596 24 8999

Facsimile : +81 596 24 8124

Conducted Emission Band Edge compliance

Test place	Ise EMC Lab. No.6 Measurement Room
Report No.	11500829H
Date	December 12, 2016
Temperature / Humidity	26 deg. C / 23 % RH
Engineer	Yutaka Yoshida
Mode	Tx DH5

Hopping On

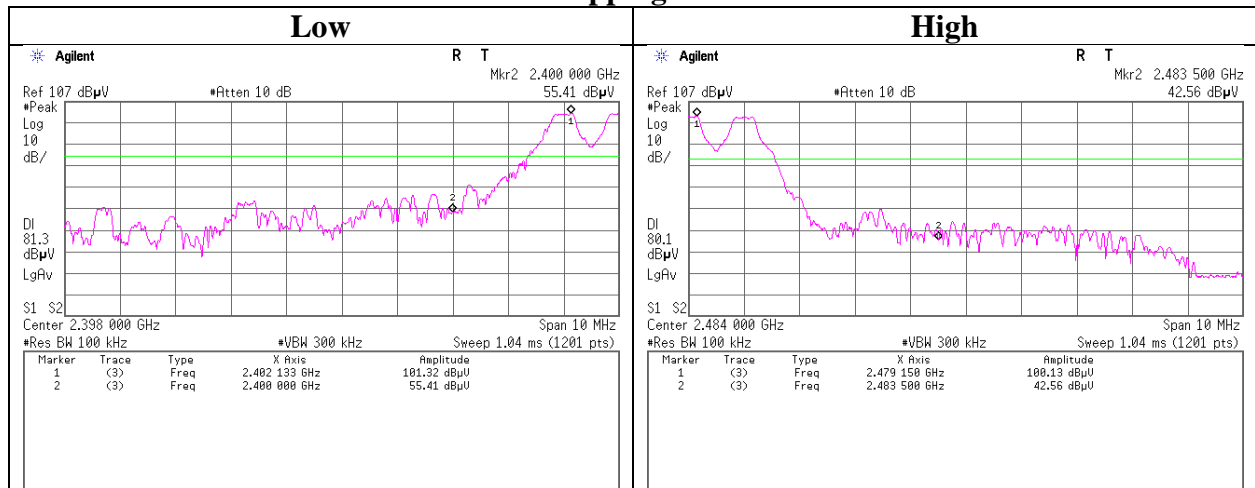

Hopping Off

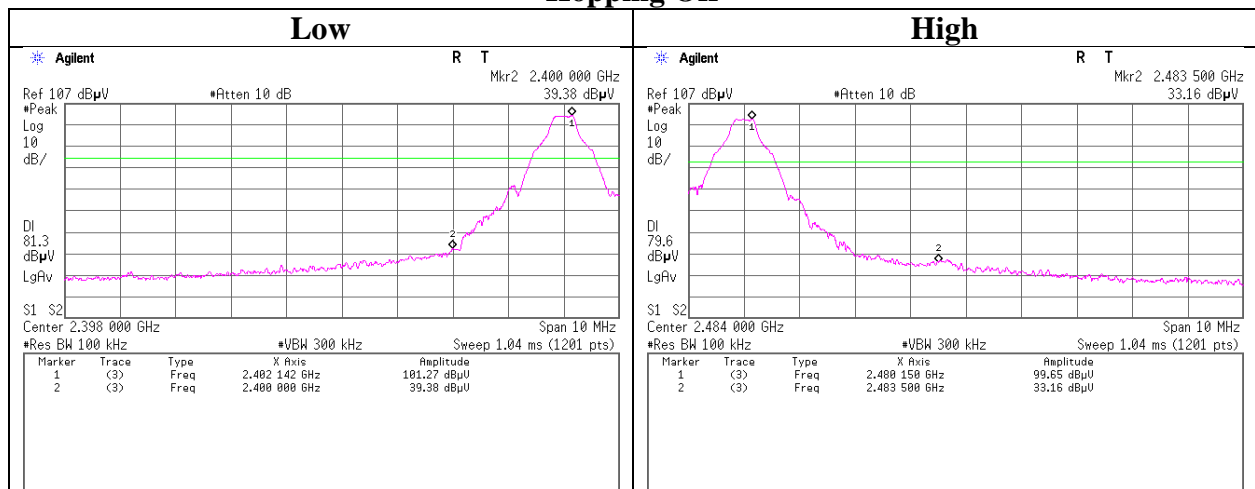

UL Japan, Inc.

Ise EMC Lab.

4383-326 Asama-cho, Ise-shi, Mie-ken 516-0021 JAPAN

Telephone : +81 596 24 8999

Facsimile : +81 596 24 8124

Conducted Emission Band Edge compliance

Test place	Ise EMC Lab. No.6 Measurement Room
Report No.	11500829H
Date	December 12, 2016
Temperature / Humidity	26 deg. C / 23 % RH
Engineer	Yutaka Yoshida
Mode	Tx 3DH5

Hopping On

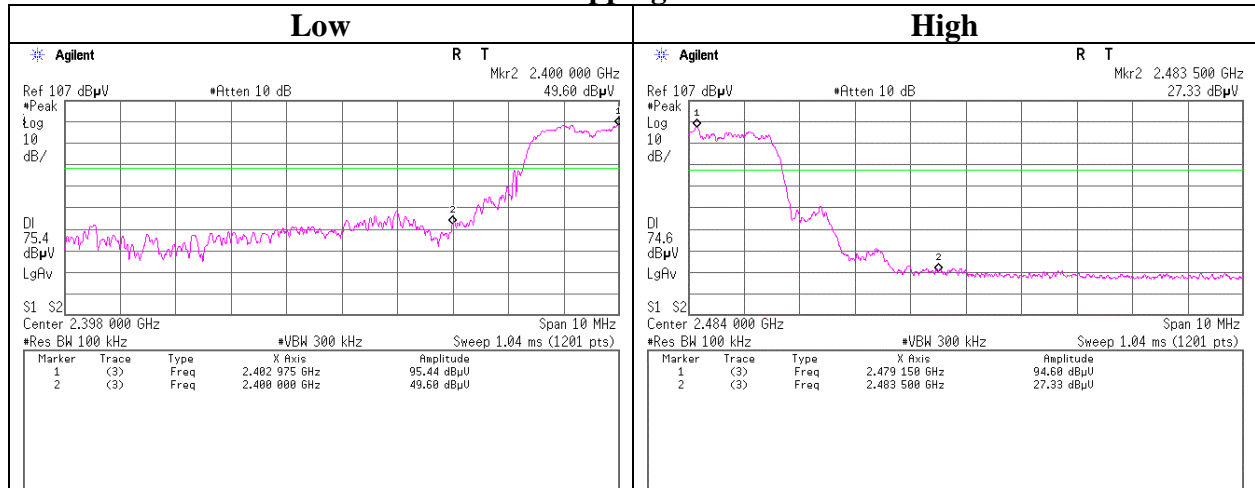

Hopping Off

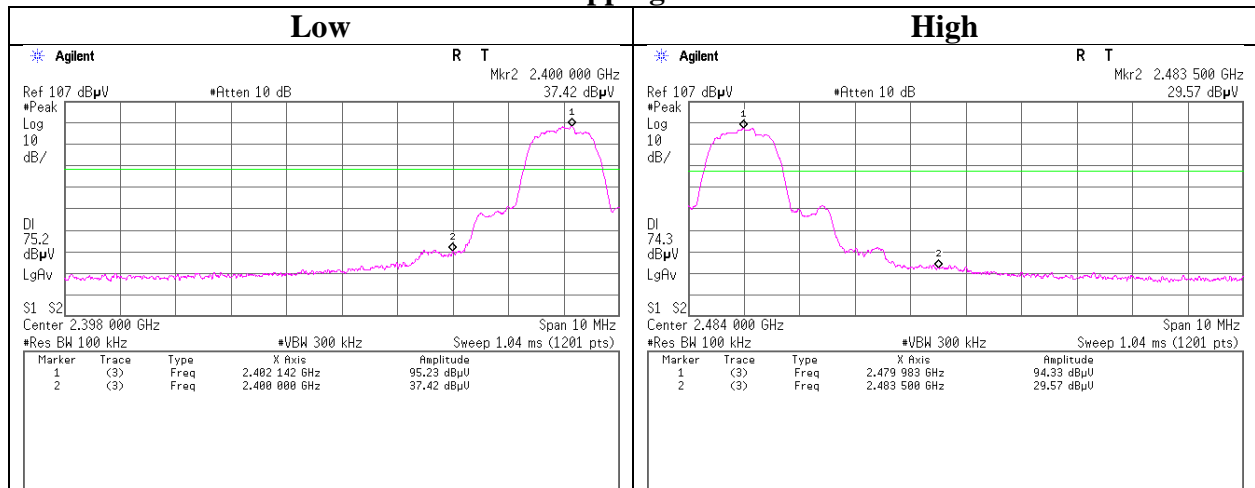

UL Japan, Inc.

Ise EMC Lab.

4383-326 Asama-cho, Ise-shi, Mie-ken 516-0021 JAPAN

Telephone : +81 596 24 8999

Facsimile : +81 596 24 8124

99% Occupied Bandwidth

Test place	Ise EMC Lab. No.6 Measurement Room
Report No.	11500829H
Date	December 12, 2016
Temperature / Humidity	23 deg. C / 68 % RH
Engineer	Yutaka Yoshida
Mode	Tx Hopping Off

Hopping Off, DH5

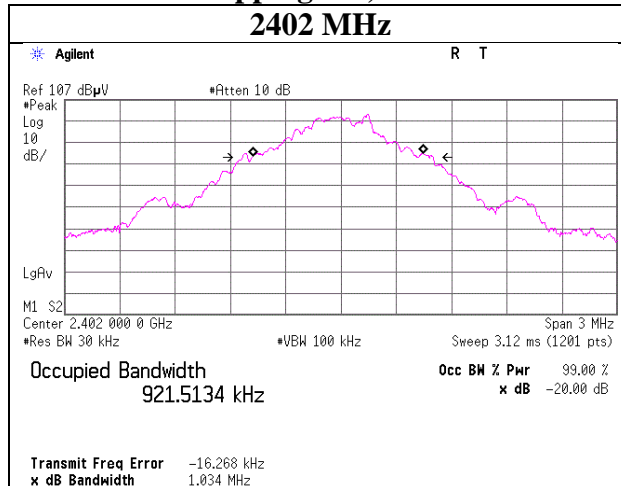

Hopping Off, 3DH5

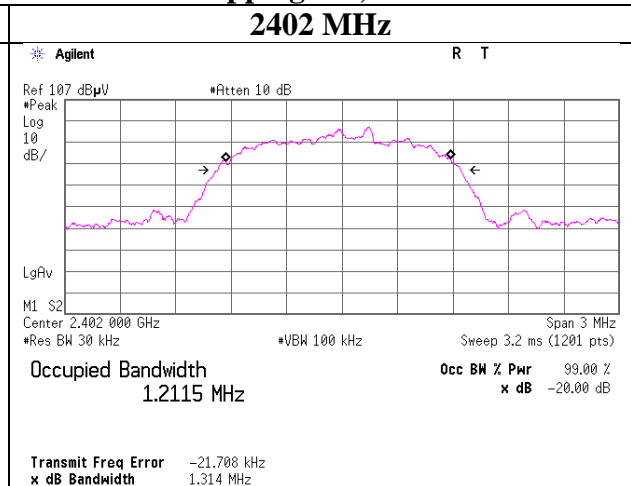

2441 MHz

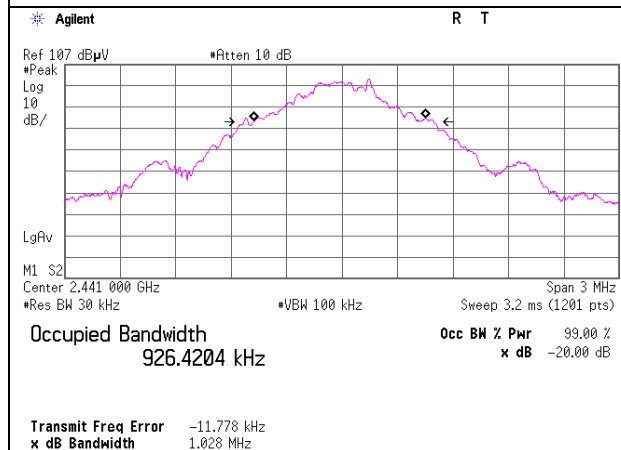

2441 MHz

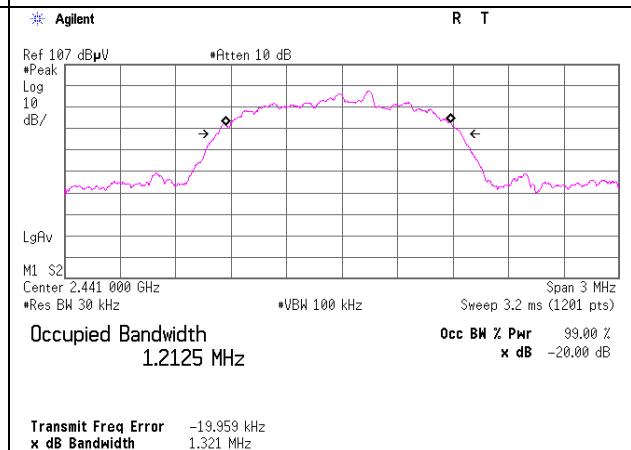

2480 MHz

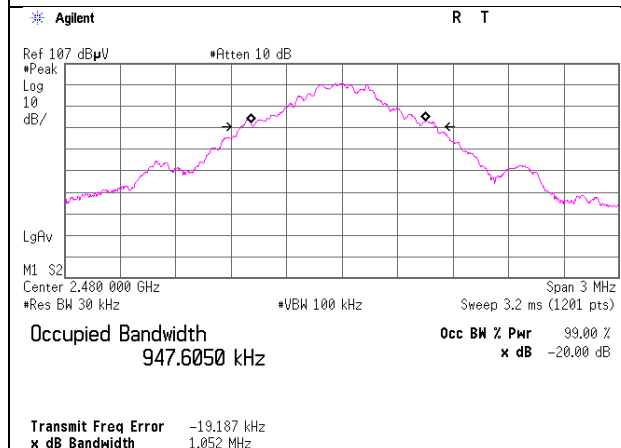

2480 MHz

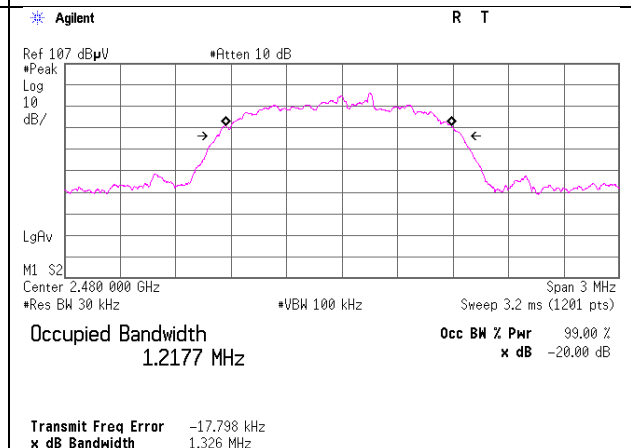

UL Japan, Inc.

Ise EMC Lab.

4383-326 Asama-cho, Ise-shi, Mie-ken 516-0021 JAPAN

Telephone : +81 596 24 8999

Facsimile : +81 596 24 8124

99% Occupied Bandwidth

Test place	Ise EMC Lab. No.6 Measurement Room
Report No.	11500829H
Date	December 12, 2016
Temperature / Humidity	26 deg. C / 23 % RH
Engineer	Yutaka Yoshida
Mode	Tx Hopping On

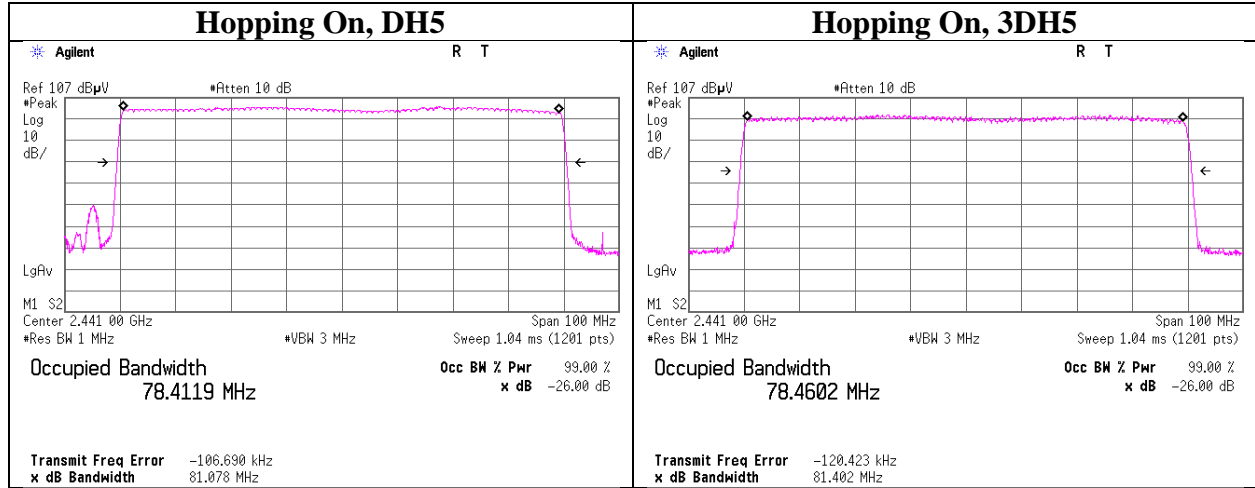

UL Japan, Inc.

Ise EMC Lab.

4383-326 Asama-cho, Ise-shi, Mie-ken 516-0021 JAPAN

Telephone : +81 596 24 8999

Facsimile : +81 596 24 8124

APPENDIX 2: Test instruments

Test equipment

Control No.	Instrument	Manufacturer	Model No	Serial No	Test Item	Calibration Date * Interval(month)
MOS-14	Thermo-Hygrometer	Custom	CTH-201	1401	AT	2016/01/21 * 12
MSA-10	Spectrum Analyzer	Agilent	E4448A	MY46180655	AT	2016/08/17 * 12
MCC-172	Microwave Cable	Junkosha	MWX221	1409S495	AT	2016/03/11 * 12
MAT-58	Attenuator(10dB)	Suhner	6810.19.A	-	AT	2016/12/15 * 12
MMM-10	DIGITAL HiTESTER	Hioki	3805	051201148	AT	2016/01/18 * 12
MPM-16	Power Meter	Agilent	8990B	MY51000271	AT	2016/04/07 * 12
MPSE-23	Power sensor	Agilent	N1923A	MY54070004	AT	2016/04/07 * 12
MCC-64	Coaxial Cable	UL Japan	-	-	AT	2016/03/10 * 12
MAT-10	Attenuator(10dB)	Weinschel Corp	2	BL1173	AT	2016/11/28 * 12
MAEC-03	Semi Anechoic Chamber(NSA)	TDK	Semi Anechoic Chamber 3m	DA-10005	RE	2016/10/20 * 12
MOS-13	Thermo-Hygrometer	Custom	CTH-180	1301	RE	2016/01/21 * 12
MJM-16	Measure	KOMELON	KMC-36	-	RE	-
COTS-MEMI	EMI measurement program	TSJ	TEPTO-DV	-	RE	-
MSA-16	Spectrum Analyzer	Agilent	E4440A	MY46186390	RE	2016/02/08 * 12
MHA-20	Horn Antenna 1-18GHz	Schwarzbeck	BBHA9120D	258	RE	2016/05/29 * 12
MCC-167	Microwave Cable	Junkosha	MWX221	1404S374(1m) / 1405S074(5m)	RE	2016/05/20 * 12
MPA-11	MicroWave System Amplifier	Agilent	83017A	MY39500779	RE	2016/03/24 * 12
MMM-08	DIGITAL HiTESTER	Hioki	3805	051201197	RE	2016/01/13 * 12
MHF-25	High Pass Filter 3.5-18.0GHz	UL Japan	HPF SELECTOR	001	RE	2016/09/21 * 12
MHA-16	Horn Antenna 15-40GHz	Schwarzbeck	BBHA9170	BBHA9170306	RE	2016/05/29 * 12
MTR-08	Test Receiver	Rohde & Schwarz	ESCI	100767	RE	2016/09/15 * 12
MBA-03	Biconical Antenna	Schwarzbeck	BBA9106	1915	RE	2016/10/15 * 12
MLA-22	Logperiodic Antenna(200-1000MHz)	Schwarzbeck	VUSLP9111B	911B-191	RE	2016/01/30 * 12
MCC-51	Coaxial cable	UL Japan	-	-	RE	2016/07/26 * 12
MAT-98	Attenuator	KEYSIGHT	8491A	MY52462349	RE	2016/12/05 * 12
MPA-13	Pre Amplifier	SONOMA INSTRUMENT	310	260834	RE	2016/03/24 * 12

The expiration date of the calibration is the end of the expired month.

All equipment is calibrated with valid calibrations. Each measurement data is traceable to the national or international standards.

As for some calibrations performed after the tested dates, those test equipment have been controlled by means of an unbroken chains of calibrations.

**Test Item: RE: Radiated Emission test
AT: Antenna Terminal Conducted test**

UL Japan, Inc.

Ise EMC Lab.

4383-326 Asama-cho, Ise-shi, Mie-ken 516-0021 JAPAN

Telephone : +81 596 24 8999

Facsimile : +81 596 24 8124