



# RADIO TEST REPORT

Test Report No. : 11085654H-B

**Applicant** : Panasonic Corporation of North America  
**Type of Equipment** : Wireless LAN Module  
**Model No.** : WJ-VR3004  
**FCC ID** : ACJ9TAWJ-VR3004  
**Test regulation** : FCC Part 15 Subpart E: 2015  
(DFS test only)  
**Test Result** : Complied

1. This test report shall not be reproduced in full or partial, without the written approval of UL Japan, Inc.
2. The results in this report apply only to the sample tested.
3. This sample tested is in compliance with above regulation.
4. The test results in this report are traceable to the national or international standards.
5. This test report must not be used by the customer to claim product certification, approval, or endorsement by NVLAP, NIST, or any agency of the Federal Government.
6. This test report covers Radio technical requirements. It does not cover administrative issues such as Manual or non-Radio test related Requirements. (if applicable)

**Date of test:** April 20 and 21, 2016

**Representative test engineer:**

*S. Matsuyama*  
Satofumi Matsuyama  
Engineer  
Consumer Technology Division

**Approved by:**

*Tsubasa Takayama*  
Tsubasa Takayama  
Engineer  
Consumer Technology Division



NVLAP LAB CODE: 200572-0

This laboratory is accredited by the NVLAP LAB CODE 200572-0, U.S.A. The tests reported herein have been performed in accordance with its terms of accreditation.

\*As for the range of Accreditation in NVLAP, you may refer to the WEB address,  
[http://japan.ul.com/resources/emc\\_accredited/](http://japan.ul.com/resources/emc_accredited/)

**UL Japan, Inc.**  
**Ise EMC Lab.**

4383-326 Asama-cho, Ise-shi, Mie-ken 516-0021 JAPAN

Telephone : +81 596 24 8999

Facsimile : +81 596 24 8124

13-EM-F0429



<b>CONTENTS</b>	<b>PAGE</b>
<b>SECTION 1: Customer information.....</b>	<b>4</b>
<b>SECTION 2: Equipment under test (E.U.T.).....</b>	<b>4</b>
<b>SECTION 3: Scope of Report.....</b>	<b>4</b>
<b>SECTION 4: Test specification, procedures &amp; results.....</b>	<b>5</b>
<b>SECTION 5: Operation of E.U.T. during testing.....</b>	<b>10</b>
<b>SECTION 6: U-NII Detection Bandwidth.....</b>	<b>17</b>
<b>SECTION 7: Initial Channel Availability Check Time .....</b>	<b>19</b>
<b>SECTION 8: Radar Burst at the Beginning of the Channel Availability Check Time.....</b>	<b>20</b>
<b>SECTION 9: Radar Burst at the End of the Channel Availability Check Time .....</b>	<b>21</b>
<b>SECTION 10: Non-Occupancy Period .....</b>	<b>22</b>
<b>SECTION 11: In-Service Monitoring(Statistical Performance Check) .....</b>	<b>23</b>
<b>APPENDIX 1: Data of DFS test .....</b>	<b>25</b>
<b>APPENDIX 2: Test instruments .....</b>	<b>60</b>
<b>APPENDIX 3: Photographs of test setup .....</b>	<b>61</b>

## **SECTION 1: Customer information**

Company Name : Panasonic System Networks Co., Ltd.\*  
Address : 1-62, 4-chome, Minoshima, Hakata-ku, Fukuoka 812-853 Japan  
Telephone Number : +81-50-3380-6162  
Facsimile Number : +81-92-477-1487  
Contact Person : Yukio Kaneko

\* Panasonic System Networks Co., Ltd. is on behalf of the applicant: Panasonic Corporation of North America.

## **SECTION 2: Equipment under test (E.U.T.)**

### **2.1 Identification of E.U.T.**

Type of Equipment : Wireless LAN Module  
Model No. : WJ-VR3004  
Serial No. : Refer to Section 4, Clause 4.2  
Rating : DC10.5V  
Receipt Date of Sample : April 8, 2016  
Country of Mass-production : Japan  
Condition of EUT : Production prototype  
(Not for Sale: This sample is equivalent to mass-produced items.)  
Modification of EUT : No Modification by the test lab

### **2.2 Product Description**

#### **General Specification**

Clock frequency(ies) in the system : 32.768kHz, 38.4MHz

#### **Radio Specification**

##### **[WLAN (IEEE802.11a/b/g/n-20)]**

Equipment Type	Transceiver	
Frequency of Operation	2412-2462MHz	W53: 5280-5320MHz W58: 5745-5825MHz
Type of Modulation	DSSS, OFDM	OFDM
Antenna Type	Dual (Planar patch)	Dual (Inverted F)
Antenna connector type	Module side: Rectangular Coaxial Connector (SMT) Antenna side: RP-SMA	
Antenna Gain with cable loss	0.58dBi (2.4GHz)	-0.98dBi (5GHz)

##### **[WLAN (IEEE802.11n-40)]**

Equipment Type	Transceiver	
Frequency of Operation	2422-2452MHz	W53: 5310MHz W58: 5755-5795MHz
Type of Modulation	OFDM	OFDM
Antenna Type	Dual (Planar patch)	Dual (Inverted F)
Antenna connector type	Module side: Rectangular Coaxial Connector (SMT) Antenna side: RP-SMA	
Antenna Gain with cable loss	0.58dBi (2.4GHz)	-0.98dBi (5GHz)

## **SECTION 3: Scope of Report**

This report only covers DFS requirement, as specified by the following referenced procedures.

**UL Japan, Inc.**

**Ise EMC Lab.**

4383-326 Asama-cho, Ise-shi, Mie-ken 516-0021 JAPAN

Telephone : +81 596 24 8999

Facsimile : +81 596 24 8124

## **SECTION 4: Test specification, procedures & results**

### **4.1 Test Specification**

Test Specification	:	FCC Part 15 Subpart E: 2015, final revised on November 23, 2015 *Some parts are effective on and after December 17, 2015 or December 23, 2015. The revision does not affect the test specification applied to the EUT.
Title	:	FCC 47CFR Part15 Radio Frequency Device Subpart E Unlicensed National Information Infrastructure Devices Section 15.407 General technical requirements
Test Specification	:	KDB905462 D02 UNII DFS Compliance Procedures New Rules v02
Title	:	COMPLIANCE MEASUREMENT PROCEDURES FOR UNLICENSED- NATIONAL INFORMATION INFRASTRUCTURE DEVICES OPERATING IN THE 5250-5350MHz AND 5470-5725MHz BANDS INCORPORATING DYNAMIC FREQUENCY SELECTION
Test Specification	:	KDB905462 D04 Operational Modes for DFS Testing New Rules v01
Title	:	OPERATIONAL MODES SUGGESTED FOR DFS TESTING

#### **FCC Part 15.31 (e)**

The RF Module has its own regulator.

The RF Module is constantly provided voltage (DC3.3/1.8V) through the regulator regardless of input voltage.

Therefore, this EUT complies with the requirement.

#### **FCC Part 15.203/212 Antenna requirement**

The EUT has a unique coupling/antenna connector (Module side: Rectangular Coaxial Connector (SMT), Antenna side: RP-SMA).

Therefore the equipment complies with the requirement of 15.203/212.

---

**UL Japan, Inc.**

**Ise EMC Lab.**

4383-326 Asama-cho, Ise-shi, Mie-ken 516-0021 JAPAN

Telephone : +81 596 24 8999

Facsimile : +81 596 24 8124

## 4.2 Procedures and results

**Table 1: Applicability of DFS Requirements**

<Master mode>

Requirement	Operating Mode	Test Procedures	Limits	Deviation	Results
	Master				
U-NII Detection Bandwidth	Yes	FCC/IC: KDB905462 D02 7.8.1	FCC/IC:KDB905462 D02 5.3	N/A	Complied
Initial Channel Availability Check Time	Yes	FCC/IC: KDB905462 D02 7.8.2.1	FCC:FCC15.407(h)(2)(ii) IC:RSS-247 6.3(2)(ii)	N/A	Complied *1
Radar Burst at the Beginning of the Channel Availability Check Time	Yes	FCC/IC: KDB905462 D02 7.8.2.2	FCC:FCC15.407(h)(2)(ii) IC:RSS-247 6.3(2)(ii)	N/A	Complied *1
Radar Burst at the End of the Channel Availability Check Time	Yes	FCC/IC: KDB905462 D02 7.8.2.3	FCC:FCC15.407(h)(2)(ii) IC:RSS-247 6.3(2)(ii)	N/A	Complied *1
In-Service Monitoring for Channel Move Time, Channel Closing Transmission Time	Yes	FCC/IC: KDB905462 D02 7.8.3	FCC:FCC15.407(h)(2)(iii) IC:RSS-247 6.3(2)(iii)(iv)	N/A	N/A *3
In-Service Monitoring for Non-Occupancy period	Yes	FCC/IC: KDB905462 D02 7.8.3	FCC: FCC15.407(h)(2)(iv) IC:RSS-247 6.3(2)(v)	N/A	Complied *1
Statistical Performance Check	Yes	FCC/IC: KDB905462 D02 7.8.4	FCC/IC:KDB905462 D02 6.1,6.2,6.3	N/A	Complied *2

Note: UL Japan, Inc.'s EMI Work Procedures No. 13-EM-W0422.

\*1) The test was performed with only Rader Type1 which was changed due to the update of KDB905462 D02.

\*2) The test was performed with only Rader Type1 and 5 which was changed due to the update of KDB905462 D02.

\*3) Please refer to original test report (10229481H-C-R1).

**UL Japan, Inc.**

**Ise EMC Lab.**

4383-326 Asama-cho, Ise-shi, Mie-ken 516-0021 JAPAN

Telephone : +81 596 24 8999

Facsimile : +81 596 24 8124

**Table 2 DFS Detection Thresholds for Master Devices and Client Devices With Radar Detection**

Maximum Transmit Power	Value (See Notes 1,2, and 3)
≥ 200 milliwatt	-64 dBm
< 200 milliwatt and power spectral density < 10dBm/MHz	-62 dBm
< 200 milliwatt that do not meet the power spectral density requirement	-64 dBm
<p>Note 1: This is the level at the input of the receiver assuming a 0 dBi receive antenna.</p> <p>Note 2: Throughout these test procedures an additional 1 dB has been added to the amplitude of the test transmission waveforms to account for variations in measurement equipment. This will ensure that the test signal is at or above the detection threshold level to trigger a DFS response.</p> <p>Note 3: EIRP is based on the highest antenna gain. For MIMO devices refer to KDB Publication 662911 D01.</p>	

**Table 3 DFS Response Requirement Values**

Parameter	Value
Non-occupancy period	Minimum 30 minutes
Channel Availability Check Time	60 seconds
Channel Move Time	10 seconds See Note 1
Channel Closing Transmission Time	200 milliseconds + an aggregate of 60 milliseconds over remaining 10 second period. See Notes 1 and 2
U-NII Detection Bandwidth	Minimum 100% of the U-NII 99% transmission power bandwidth See Note 3
<p><b>Note 1:</b> Channel Move Time and the Channel Closing Transmission Time should be performed with Radar Type 0. The measurement timing begins at the end of the Radar Type 0 burst.</p> <p><b>Note 2:</b> The Channel Closing Transmission Time is comprised of 200 milliseconds starting at the beginning of the Channel Move Time plus any additional intermittent control signals required to facilitate a Channel move (an aggregate of 60 milliseconds) during the remainder of the 10 second period. The aggregate duration of control signal will not count quiet periods in between transmissions.</p> <p><b>Note 3:</b> During the U-NII Detection Bandwidth detection test, radar type 0 should be used. For each frequency step the minimum percentage of detection is 90 percent. Measurements are performed with no data traffic.</p>	

**Table 4 Short Pulse Radar Test Waveform**

Radar Type	Pulse Width (μsec)	PRI (μsec)	Number of Pulses	Minimum Percentage of Successful Detection	Minimum Number of Trials
0	1	1428	18	See Note 1	See Note 1
1	1	Test A: 15 unique PRI values randomly selected from the list of 23 PRI values in Table 5a	Roundup $\{(1/360) * (19 * 10^6 / \text{PRI}_{\text{μsec}})\}$	60%	30
		Test B: 15 unique PRI values randomly selected within the range of 518-3066 μsec, with a minimum increment of 1 μsec, excluding PRI values selected in Test A			
2	1-5	150-230	23-29	60%	30
3	6-10	200-500	16-18	60%	30
4	11-20	200-500	12-16	60%	30
Aggregate (Rader Types 1-4)				80%	120
Note 1: Short Pulse Radar Type 0 should be used for the detection bandwidth test, channel move time, and channel closing time tests.					

**Table 5 Long Pulse Radar Test Waveform**

Radar Type	Pulse Width (μsec)	Chip Width (MHz)	PRI (μsec)	Number of Pulses per Burst	Number of Burst	Minimum Percentage of Successful Detection	Minimum Number of Trials
5	50-100	5-20	1000-2000	1-3	8-20	80%	30

**Table 6 Frequency Hopping Radar Test Waveform**

Radar Type	Pulse Width (μsec)	PRI (μsec)	Pulse per Hop (kHz)	Hopping Rate (kHz)	Hopping Sequence Length (msec)	Minimum Percentage of Successful Detection	Minimum Number of Trials
6	1	333	9	0.333	300	70%	30

### 4.3 Test Location

UL Japan, Inc. Ise EMC Lab. \*NVLAP Lab. code: 200572-0  
4383-326 Asama-cho, Ise-shi, Mie-ken 516-0021 JAPAN  
Telephone : +81 596 24 8999 Facsimile : +81 596 24 8124

	IC Registration Number	Width x Depth x Height (m)	Size of reference ground plane (m) / horizontal conducting plane	Other rooms
No.1 semi-anechoic chamber	2973C-1	19.2 x 11.2 x 7.7m	7.0 x 6.0m	No.1 Power source room
No.2 semi-anechoic chamber	2973C-2	7.5 x 5.8 x 5.2m	4.0 x 4.0m	-
No.3 semi-anechoic chamber	2973C-3	12.0 x 8.5 x 5.9m	6.8 x 5.75m	No.3 Preparation room
No.3 shielded room	-	4.0 x 6.0 x 2.7m	N/A	-
No.4 semi-anechoic chamber	2973C-4	12.0 x 8.5 x 5.9m	6.8 x 5.75m	No.4 Preparation room
No.4 shielded room	-	4.0 x 6.0 x 2.7m	N/A	-
No.5 semi-anechoic chamber	-	6.0 x 6.0 x 3.9m	6.0 x 6.0m	-
No.6 shielded room	-	4.0 x 4.5 x 2.7m	4.0 x 4.5 m	-
No.6 measurement room	-	4.75 x 5.4 x 3.0m	4.75 x 4.15 m	-
No.7 shielded room	-	4.7 x 7.5 x 2.7m	4.7 x 7.5m	-
No.8 measurement room	-	3.1 x 5.0 x 2.7m	N/A	-
No.9 measurement room	-	8.0 x 4.6 x 2.8m	2.4 x 2.4m	-
No.11 measurement room	-	6.2 x 4.7 x 3.0m	4.8 x 4.6m	-

\* Size of vertical conducting plane (for Conducted Emission test) : 2.0 x 2.0m for No.1, No.2, No.3, and No.4 semi-anechoic chambers and No.3 and No.4 shielded rooms.

### 4.4 Uncertainty

The following uncertainties have been calculated to provide a confidence level of 95% using a coverage factor k=2.  
Time Measurement uncertainty for this test was: (±) 0.012%

### 4.5 Data of DFS test, Test instruments of DFS, Test set up

Refer to APPENDIX.

## UL Japan, Inc. Ise EMC Lab.

4383-326 Asama-cho, Ise-shi, Mie-ken 516-0021 JAPAN  
Telephone : +81 596 24 8999  
Facsimile : +81 596 24 8124

## **SECTION 5: Operation of E.U.T. during testing**

### **5.1 Operating Modes**

The EUT, which is a Master Device, operates over the 5250-5350MHz.

Power level(EIRP) of the EUT[dBm]

5250-5350MHz Band*	
Output Power (Max)	
20Mband	40Mband
15.12	14.64

\*Refer to 10229481H-B, FCC Part 15E (FCC 15.407) report for other parts than DFS.

The channel-loading of approximately 17% or greater was used for testing, and its test data was transferred from the Master Device to the Client Device for all test configurations.

The EUT utilizes the 802.11n architecture, with a 20MHz and 40MHz channel bandwidth.

WLAN traffic is generated by streaming the MPEG Test file “6 ½ Magic Hours” from the Master to the Client in full motion video mode.

#### 1. In case of Master mode

The rated output power of the Master unit is <200mW(23dBm). Therefore the required interference threshold level is -62 dBm. After correction for antenna gain and procedural adjustments, the required conducted threshold at the antenna port is  $-62 + 1 + (-0.98) + 1.2 = -60.78$  dBm (threshold level + additional 1dB + antenna gain with cable loss + cable loss).

It is impossible for users to change DFS control, because the DFS function is written on the firmware and users cannot access it.

The EUT was set by the software as follows:

Software name & version: Dut Wlan BT Labtool Version 1.0.8.1.6

---

**UL Japan, Inc.**

**Ise EMC Lab.**

4383-326 Asama-cho, Ise-shi, Mie-ken 516-0021 JAPAN

Telephone : +81 596 24 8999

Facsimile : +81 596 24 8124

## 5.2 Configuration and peripherals

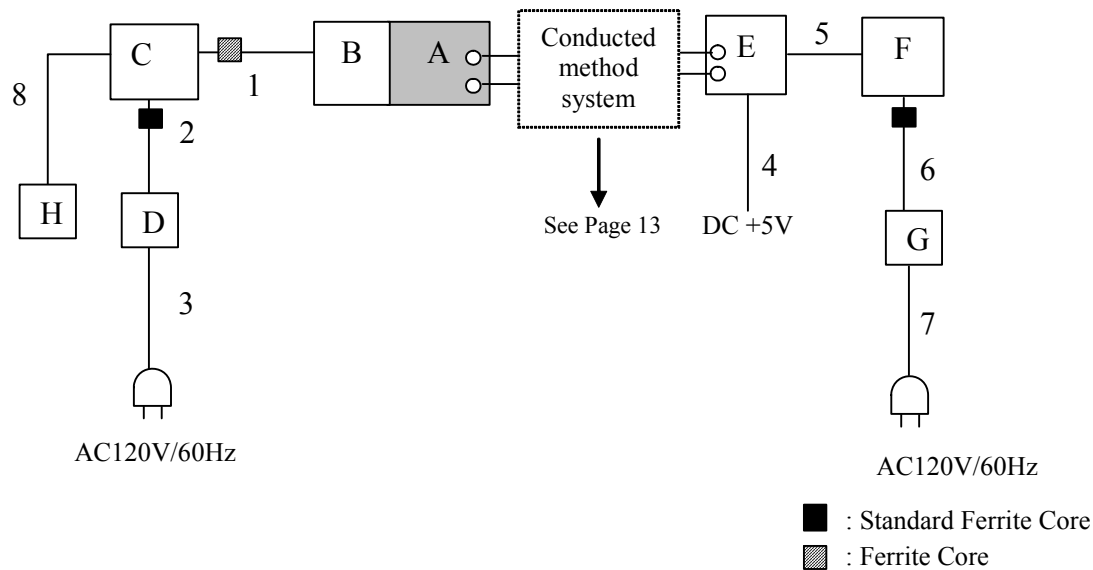

### Description of EUT and Support equipment

No.	Item	Model number	Serial number	Manufacturer	Remarks
A	WLAN Module	WJ-VR3004	4T7V	Panasonic	EUT
B	Jig Board	-	-	Panasonic	-
C	Laptop PC	CF-31	1AKSA41769	Panasonic	-
D	AC Adaptor	CF-AA1652A	05500198B	Panasonic	-
E	WLAN Module	WYSBCVJXM	-	TAIYO YUDEN	-
F	Laptop PC	FMV-B8240	R7901207	FUJITSU	-
G	AC Adaptor	SEB55N2-16-0	08X03576A	FUJITSU	-
H	Mouse	M-U0026	1552HS02RRR8	Logicool	-

### List of cables used

No.	Name	Length (m)	Shield		Remarks
			Cable	Connector	
1	USB Cable	1.0	Shielded	Shielded	*1)
2	DC Cable	1.8	Unshielded	Unshielded	
3	AC Cable	1.9	Unshielded	Unshielded	
4	DC Cable	0.5	Unshielded	Unshielded	
5	USB Cable	1.8	Shielded	Shielded	
6	DC Cable	1.2	Unshielded	Unshielded	
7	AC Cable	2.0	Unshielded	Unshielded	
8	USB Cable	1.8	Shielded	Shielded	

<Notes for Ferrite cores>

\*1) Ferrite Core, Model No. (Manufacturer: KITAGAWA INDUSTRIES CO.,LTD.), 5cm from Item C, 1 turn.

**UL Japan, Inc.**

**Ise EMC Lab.**

4383-326 Asama-cho, Ise-shi, Mie-ken 516-0021 JAPAN

Telephone : +81 596 24 8999

Facsimile : +81 596 24 8124

## 5.3 Test and Measurement System

### SYSTEM OVERVIEW

The measurement system is based on a conducted test method.

The software selects waveform parameters from within the bounds of the signal type on a random basis using uniform distribution. The short pulse type 1 and the long pulse type 5 parameters are randomized at run-time.

The signal monitoring equipment consists of a spectrum analyzer with the capacity to display 8001 bins on the horizontal axis. A time-domain resolution of 2 msec/bin is achievable with a 16 second sweep time, meeting the 10 seconds short pulse reporting criteria. The aggregate ON time is calculated by multiplying the number of bins above a threshold during a particular observation period by the dwell time per bin, with the analyzer set to peak detection.

---

**UL Japan, Inc.**

**Ise EMC Lab.**

4383-326 Asama-cho, Ise-shi, Mie-ken 516-0021 JAPAN

Telephone : +81 596 24 8999

Facsimile : +81 596 24 8124

**CONDUCTED METHODS SYSTEM BLOCK DIAGRAM**

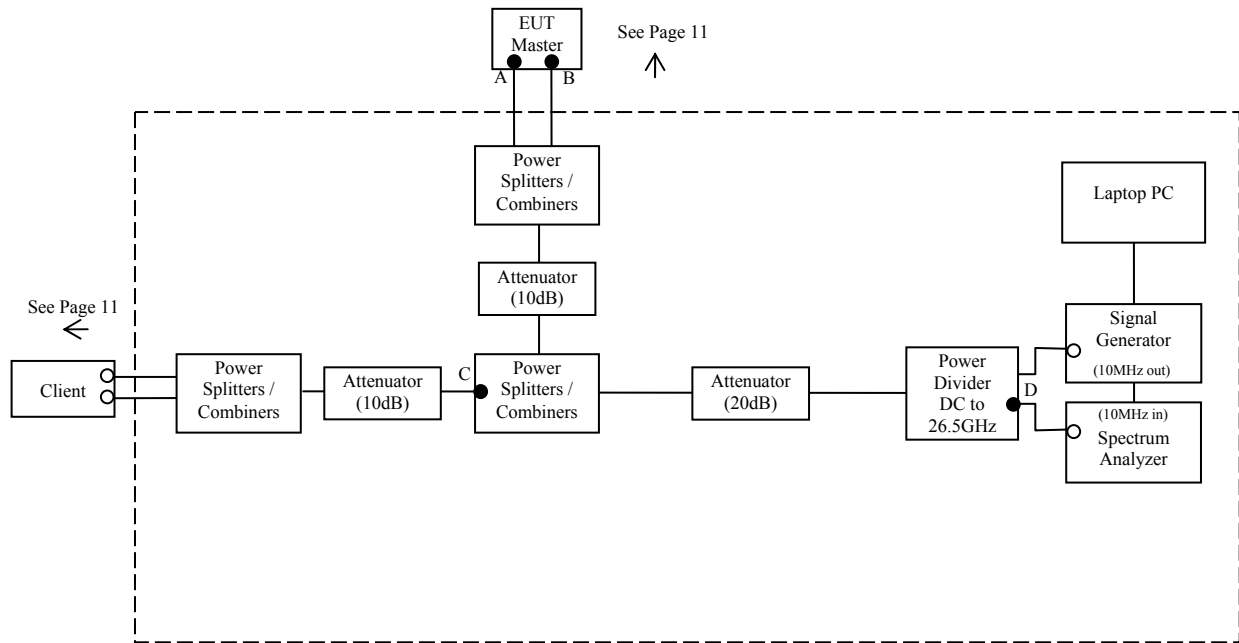

**MEASUREMENT SYSTEM FREQUENCY REFERENCE**

Lock the signal generator and the spectrum analyzer to the same reference sources as follows: Connect the 10MHz OUT on the signal generator to the 10MHz IN on the spectrum analyzer and set the spectrum analyzer 10MHz In to On.

## **SYSTEM CALIBRATION**

<Master mode>

**Step 1:** Set the system as shown in Figure 2 of KDB905462 D02 7.2.1.

**Step 2:** Adjust each attenuator to fulfill the following three conditions:

- WLAN can be communicated, and
- Rader detection threshold level is bigger than Master Device traffic level on the spectrum analyzer, and
- Client Device traffic level is not displayed on the spectrum analyzer.

**Step 3:** Terminate 50 ohm at B, C, and D points, and connect the spectrum analyzer to the point A. (See the figure on page 13)

At the point A, adjust the signal generator and spectrum analyzer to the center frequency of the channel to be measured.

Download the applicable radar waveforms to the signal generator. Select the radar waveform, trigger a burst manually and measure the amplitude on the spectrum analyzer. Readjust the amplitude of the signal generator as required so that the peak level of the waveform is at a displayed level equal to the required or desired interference detection threshold.

Separate signal generator amplitude settings are determined as required for each radar type.

Terminate at the points A, C, and D and confirm at the point B if it has the same value as point A.

If necessary, add the attenuator to make the same level.

**Step 4:** Without changing any of the instrument settings, restore the system setting to Step 2 and adjust the Reference Level Offset of the spectrum analyzer to the level at Step 3.

By taking the above steps 1 to 4, the spectrum analyzer displays the level of the signal generator as received at the antenna ports of the Master Device.

See Clause 5.4 for Plots of Noise, Rader Waveforms, and WLAN signals.

---

**UL Japan, Inc.**

**Ise EMC Lab.**

4383-326 Asama-cho, Ise-shi, Mie-ken 516-0021 JAPAN

Telephone : +81 596 24 8999

Facsimile : +81 596 24 8124

5.4 Plots of Noise, Rader Waveforms, and WLAN signals

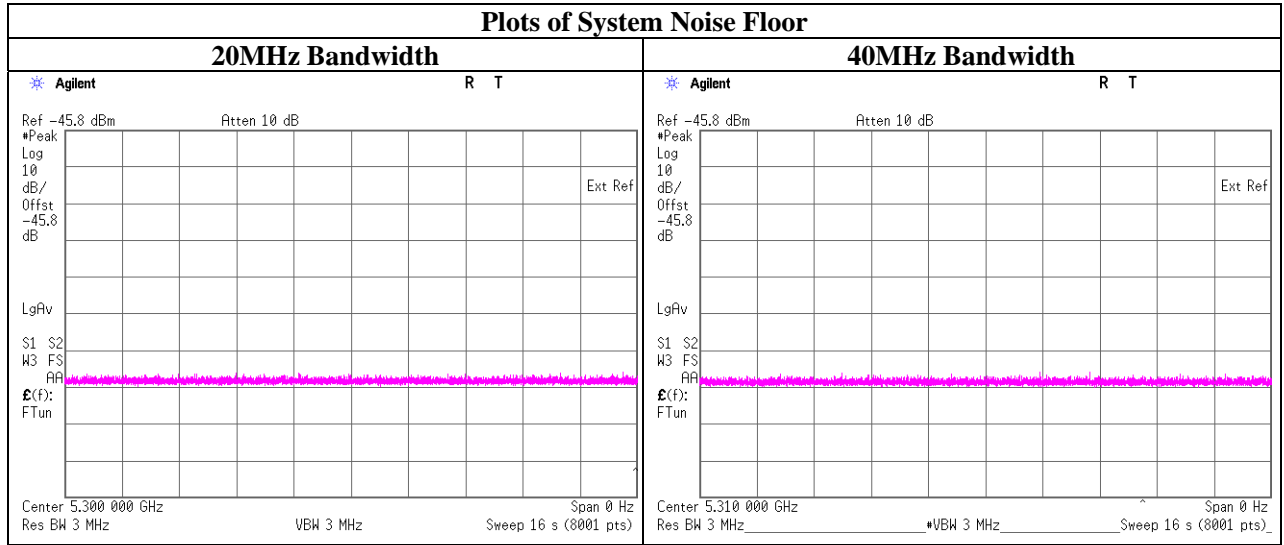

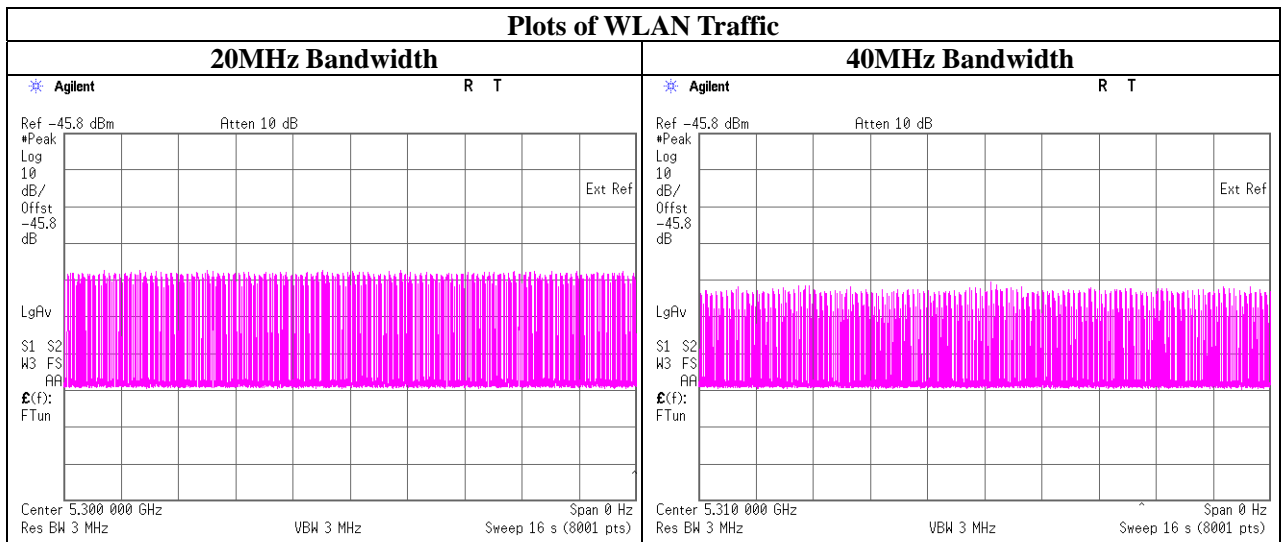
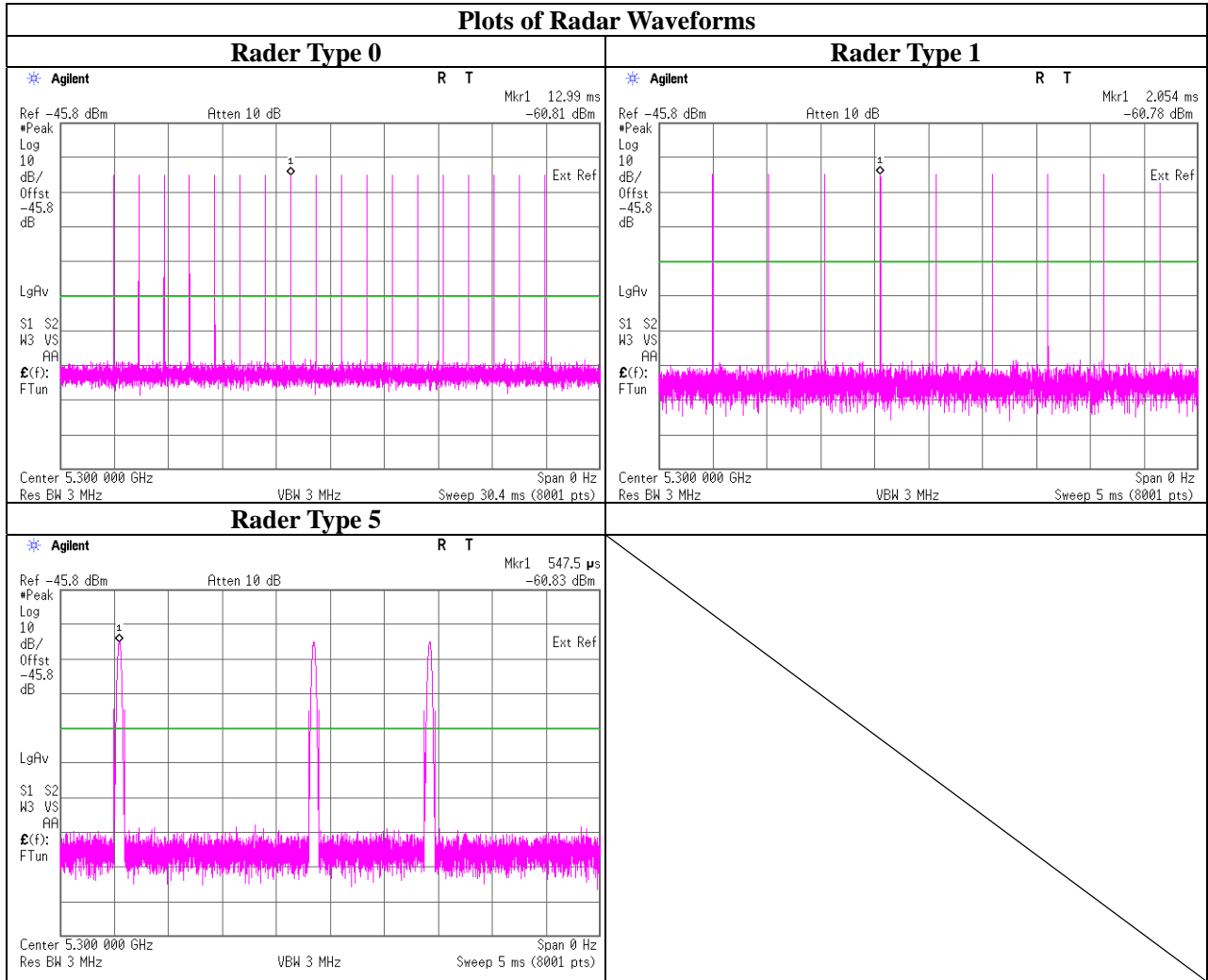

## **SECTION 6: U-NII Detection Bandwidth**

### **6.1 Operating environment**

Test place : Ise EMC Lab. No.6 measurement room  
Date : 04/21/2016  
Temperature/ Humidity : 20deg. C / 58% RH  
Engineer : Satofumi Matsuyama

### **6.2 Test Procedure**

Adjust the equipment to produce a single Burst of the Short Pulse Radar Type 0 at the center frequency of the EUT Operating Channel at the specified DFS Detection Threshold level. Set the EUT up as a standalone device (no associated Client or Master, as appropriate) and no traffic. Frame based systems will be set to a talk/listen ratio reflecting the worst case (maximum) that is user configurable during this test.

Generate a single radar Burst, and note the response of the EUT. Repeat for a minimum of 10 trials. The EUT must detect the Radar Waveform within the DFS band using the specified U-NII Detection Bandwidth criterion. In cases where the channel bandwidth may exceed past the DFS band edge on specific channels (i.e., 802.11ac or wideband frame based systems) select a channel that has the entire emission bandwidth within the DFS band. If this is not possible, test the detection BW to the DFS band edge.

Starting at the center frequency of the EUT operating Channel, increase the radar frequency in 5 MHz steps, repeating the above test sequence, until the detection rate falls below the U-NII Detection Bandwidth criterion. Repeat this measurement in 1MHz steps at frequencies 5 MHz below where the detection rate begins to fall. Record the highest frequency (denote as FH) at which detection is greater than or equal to the U-NII Detection Bandwidth criterion. Recording the detection rate at frequencies above FH is not required to demonstrate compliance.

Starting at the center frequency of the EUT operating Channel, decrease the radar frequency in 5 MHz steps, repeating the above test sequence, until the detection rate falls below the U-NII Detection Bandwidth criterion. Repeat this measurement in 1MHz steps at frequencies 5 MHz above where the detection rate begins to fall. Record the lowest frequency (denote as FL) at which detection is greater than or equal to the U-NII Detection Bandwidth criterion. Recording the detection rate at frequencies below FL is not required to demonstrate compliance.

The U-NII Detection Bandwidth is calculated as follows:

U-NII Detection Bandwidth = FH – FL

Radar detection is observed by two techniques.

- a). Monitoring LAN traffic with Spectrum Analyzer.
- b). Indicator of EUT and PC connected to EUT

---

**UL Japan, Inc.**

**Ise EMC Lab.**

4383-326 Asama-cho, Ise-shi, Mie-ken 516-0021 JAPAN

Telephone : +81 596 24 8999

Facsimile : +81 596 24 8124

### 6.3 Test data

5300MHz (20MHz Bandwidth)

Waveform : Radar Type 0

FL [MHz]	FH [MHz]	Detection Bandwidth [MHz]	99% Power Bandwidth [MHz]	Ratio of Detection BW to 99% Power BW [%]	Limit [%]	Results
5290	5310	20	17.8936	111.8	100	Pass

5310MHz (40MHz Bandwidth)

Waveform : Radar Type 0

FL [MHz]	FH [MHz]	Detection Bandwidth [MHz]	99% Power Bandwidth [MHz]	Ratio of Detection BW to 99% Power BW [%]	Limit [%]	Results
5291	5329	38	36.3189	104.6	100	Pass

### 99% Occupied Bandwidth

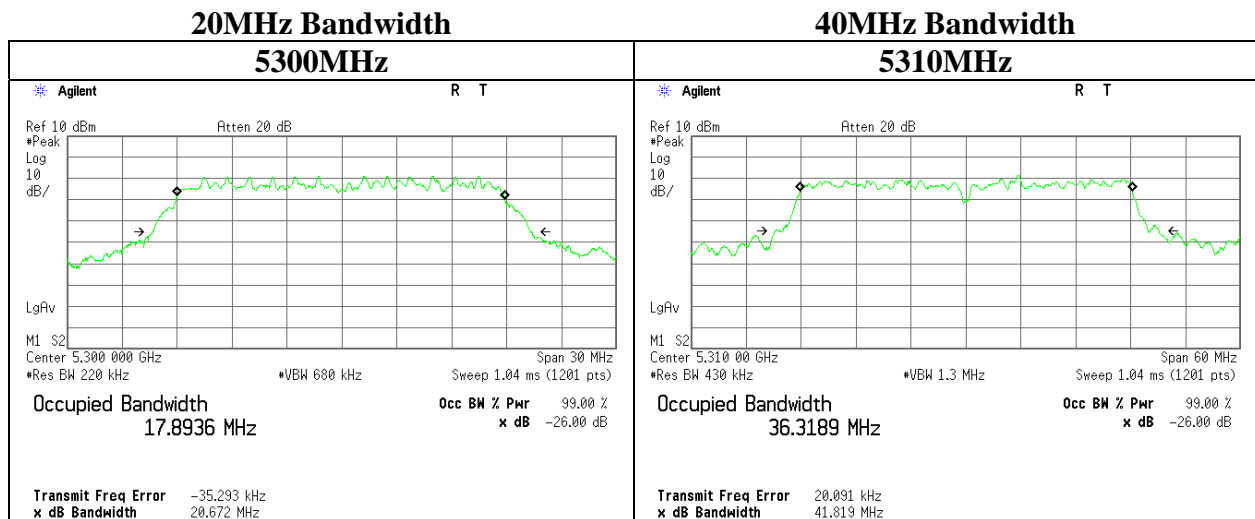

### 6.4 Test result

Test result: Pass

**UL Japan, Inc.**  
**Ise EMC Lab.**

4383-326 Asama-cho, Ise-shi, Mie-ken 516-0021 JAPAN  
Telephone : +81 596 24 8999  
Facsimile : +81 596 24 8124

## SECTION 7: Initial Channel Availability Check Time

### 7.1 Operating environment

Test place : Ise EMC Lab. No.6 measurement room  
Date : 04/21/2016  
Temperature/ Humidity : 20deg. C / 58% RH  
Engineer : Satofumi Matsuyama

### 7.2 Test Procedure

The Initial Channel Availability Check Time tests that the EUT does not emit beacon, control, or data signals on the test Channel until the power-up sequence has been completed and the U-NII device checks for Radar Waveforms for one minute on the test Channel.

This test does not use any Radar Waveforms and only needs to be performed one time.

The U-NII devices will be powered on and be instructed to operate on the appropriate U-NII Channel that must incorporate DFS functions. At the same time the EUT is powered on, the spectrum analyzer will be set to zero span mode with a 3 MHz RBW and 3 MHz VBW on the Channel occupied by the radar (Chr) with a 2.5 minute sweep time. The spectrum analyzer's sweep will be started at the same time power is applied to the U-NII device.

The EUT should not transmit any beacon or data transmissions until at least 1 minute after the completion of the power-on cycle.

### 7.3 Test data

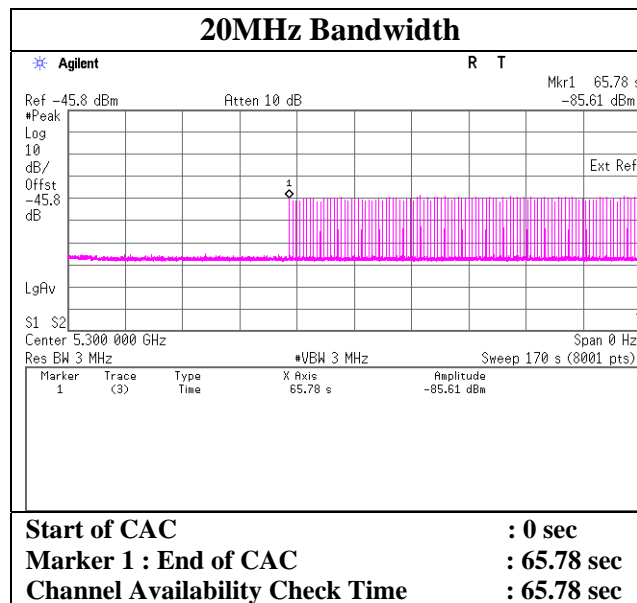

### 7.4 Test result

Test result: Pass

## SECTION 8: Radar Burst at the Beginning of the Channel Availability Check Time

### 8.1 Operating environment

Test place : Ise EMC Lab. No.6 measurement room  
Date : 04/21/2016  
Temperature/ Humidity : 20deg. C / 58% RH  
Engineer : Satofumi Matsuyama

### 8.2 Test Procedure

A single Burst of the Short Pulse Radar Type 1 will commence within a 6 second window starting at Start of CAC. An additional 1 dB is added to the radar test signal to ensure it is at or above the DFS Detection Threshold, accounting for equipment variations/errors.

Verify that during the 2.5 minute measurement window no EUT transmissions occurred on Chr.

### 8.3 Test data

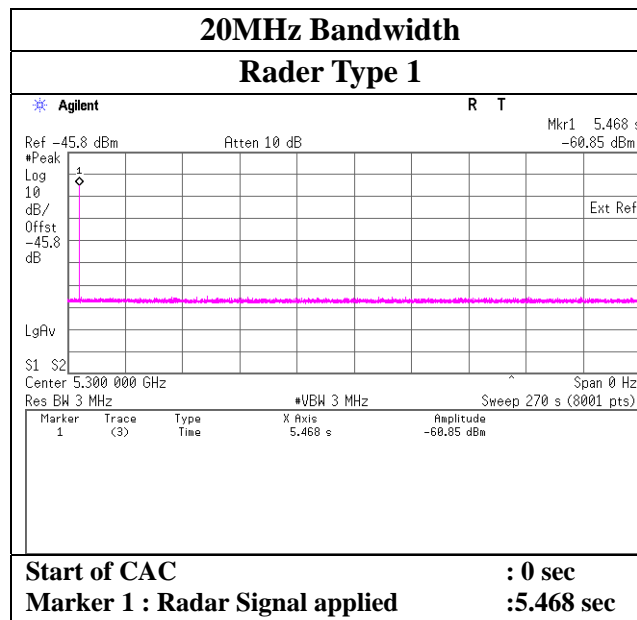

### 8.4 Test result

Test result: Pass

## SECTION 9: Radar Burst at the End of the Channel Availability Check Time

### 9.1 Operating environment

Test place : Ise EMC Lab. No.6 measurement room  
Date : 04/21/2016  
Temperature/ Humidity : 20deg. C / 58% RH  
Engineer : Satofumi Matsuyama

### 9.2 Test Procedure

A single Burst of the Short Pulse Radar Type 1 will commence within a 6 second window starting at Start of CAC + 54 seconds. An additional 1 dB is added to the radar test signal to ensure it is at or above the DFS Detection Threshold, accounting for equipment variations/errors. Verify that during the 2.5 minute measurement window no EUT transmissions occurred on Chr.

### 9.3 Test data

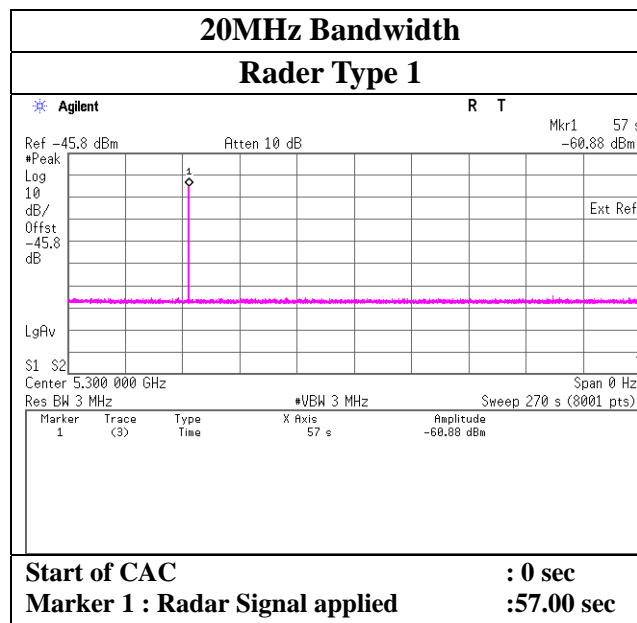

### 9.4 Test result

Test result: Pass

## SECTION 10: Non-Occupancy Period

### 10.1 Operating environment

Test place : Ise EMC Lab. No.6 measurement room  
Date : 04/21/2016  
Temperature/ Humidity : 20deg. C / 58% RH  
Engineer : Satofumi Matsuyama

### 10.2 Test Procedure

The following two tests are performed:

1).Stream the MPEG test file from the Master Device to the Client Device on the test Channel for the entire period of the test.

The Radar Waveform generator sends a Burst of pulses for one of the Radar Type 1 (Master Device) or the Radar Types 0(Client Device) at levels defined on the Operating Channel. An additional 1 dB is added to the radar test signal to ensure it is at or above the DFS Detection Threshold, accounting for equipment variations/errors.

Observe the transmissions of the EUT after the Channel Move Time on the Operating Channel for duration greater than 30 minutes.

### 10.3 Test data

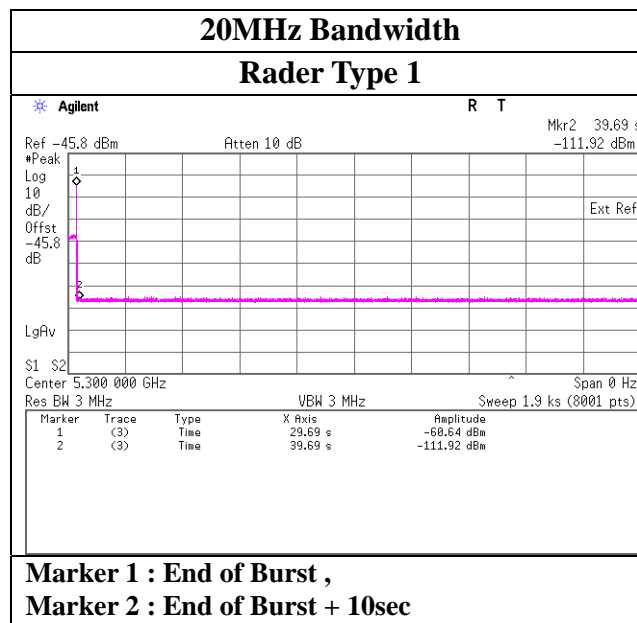

### 10.4 Test result

Test result: Pass

**UL Japan, Inc.**  
**Ise EMC Lab.**

4383-326 Asama-cho, Ise-shi, Mie-ken 516-0021 JAPAN  
Telephone : +81 596 24 8999  
Facsimile : +81 596 24 8124

## **SECTION 11: In-Service Monitoring(Statistical Performance Check)**

### **11.1 Operating environment**

Test place : Ise EMC Lab. No.6 measurement room  
Date : 04/20/2016  
Temperature/ Humidity : 24deg. C / 39% RH  
Engineer : Satofumi Matsuyama

### **11.2 Test Procedure**

Stream the MPEG test file from the Master Device to the Client Device on the test Channel for the entire period of the test.

Radar Waveform generator sends the individual waveform for each of the Radar Types 1-6, at levels defined, on the Operating Channel. An additional 1dB is added to the radar test signal to ensure it is at or above the DFS Detection Threshold, accounting for equipment variations/errors.

Observe the transmissions of the EUT at the end of the Burst on the Operating Channel for duration greater than 10 seconds for Short Pulse Radar Types 1-4 and 6 to ensure detection occurs.

Observe the transmissions of the EUT at the end of the Burst on the Operating Channel for duration greater than 22 seconds for Long Pulse Radar Type 5 to ensure detection occurs.

For long pulse radar Type 5

Three subsets of trials has been performed with a minimum of ten trials per subset. The subset of trials differ in where the Long Pulse Type 5 Signal is tuned in frequency:

- a) the Channel center frequency
- b) tuned frequencies such that 90% of the Long Pulse Type 5 frequency modulation is within the low edge of the UUT Occupied Bandwidth
- c) tuned frequencies such that 90% of the Long Pulse Type 5 frequency modulation is within the high edge of the UUT Occupied Bandwidth

Each center frequency calculated by:

the low edge of the UUT Occupied Bandwidth  $+(0.4*Chirp\ Width\ [in\ MHz])$

the high edge of the UUT Occupied Bandwidth  $-(0.4*Chirp\ Width\ [in\ MHz])$

Radar detection is observed by two techniques.

- a). Monitoring LAN traffic with Spectrum Analyzer.
- b). Indicator of PC connected to EUT

---

**UL Japan, Inc.**

**Ise EMC Lab.**

4383-326 Asama-cho, Ise-shi, Mie-ken 516-0021 JAPAN

Telephone : +81 596 24 8999

Facsimile : +81 596 24 8124

### 11.3 Test data

#### 5300MHz (20MHz Bandwidth)

Radar Type	Number of Trials	Number of Successful Detections	Percentage of Successful Detections [%]	Limit [%]	Results	Remarks
1	30	27	90.00	60	Pass	
2	30	29	96.67	60	Pass	*1
3	30	28	93.33	60	Pass	*1
4	30	21	70.00	60	Pass	*1
Aggregate of 1 to 4	-	-	87.50	80	Pass	
5	30	30	100.00	80	Pass	
6	30	29	96.67	70	Pass	*1

#### 5310MHz (40MHz Bandwidth)

Radar Type	Number of Trials	Number of Successful Detections	Percentage of Successful Detections [%]	Limit [%]	Results	Remarks
1	30	27	90.00	60	Pass	
2	30	30	100.00	60	Pass	*1
3	30	29	96.67	60	Pass	*1
4	30	24	80.00	60	Pass	*1
Aggregate of 1 to 4	-	-	91.67	80	Pass	
5	30	30	100.00	80	Pass	
6	30	30	100.00	70	Pass	*1

\*1) This data is reference data (10229481H-C-R1).

### 11.4 Test result

Test result: Pass

**UL Japan, Inc.**

**Ise EMC Lab.**

4383-326 Asama-cho, Ise-shi, Mie-ken 516-0021 JAPAN

Telephone : +81 596 24 8999

Facsimile : +81 596 24 8124

**APPENDIX 1: Data of DFS test**

**U-NII Detection Bandwidth**

**5300MHz (20MHz Bandwidth)**

Frequency [MHz]	Number of Trials [Times]	Number of Detected [Times]	Ratio of Detected [%]	Mark
5290	10	10	100	FL
5291	10	10	100	
5292	10	10	100	
5293	10	10	100	
5294	10	10	100	
5295	10	10	100	
5300	10	10	100	
5305	10	10	100	
5306	10	10	100	
5307	10	10	100	
5308	10	10	100	
5309	10	10	100	
5310	10	10	100	FH

**5310MHz (40MHz Bandwidth)**

Frequency [MHz]	Number of Trials [Times]	Number of Detected [Times]	Ratio of Detected [%]	Mark
5290	10	0	0	
5291	10	10	100	FL
5292	10	10	100	
5293	10	10	100	
5294	10	10	100	
5295	10	10	100	
5300	10	10	100	
5305	10	10	100	
5310	10	10	100	
5315	10	10	100	
5320	10	10	100	
5325	10	10	100	
5326	10	10	100	
5327	10	10	100	
5328	10	10	100	
5329	10	10	100	FH
5330	10	0	0	

**UL Japan, Inc.**  
**Ise EMC Lab.**

4383-326 Asama-cho, Ise-shi, Mie-ken 516-0021 JAPAN  
Telephone : +81 596 24 8999  
Facsimile : +81 596 24 8124

**Statistical Performance Check**

**5300MHz (20MHz Bandwidth)**

Trial #	Radar Type1	Radar Type5
	Detection	Detection
	Yes/No	Yes/No
1	YES	YES
2	YES	YES
3	NO	YES
4	YES	YES
5	YES	YES
6	NO	YES
7	YES	YES
8	YES	YES
9	YES	YES
10	YES	YES
11	YES	YES
12	YES	YES
13	YES	YES
14	YES	YES
15	YES	YES
16	YES	YES
17	YES	YES
18	YES	YES
19	YES	YES
20	NO	YES
21	YES	YES
22	YES	YES
23	YES	YES
24	YES	YES
25	YES	YES
26	YES	YES
27	YES	YES
28	YES	YES
29	YES	YES
30	YES	YES
EUT Test Frequency:5300MHz Radar Frequency:5300MHz		

**Statistical Performance Check**

**5310MHz (40MHz Bandwidth)**

Trial #	Radar Type1	Radar Type5
	Detection	Detection
	Yes/No	Yes/No
1	YES	YES
2	YES	YES
3	YES	YES
4	YES	YES
5	YES	YES
6	YES	YES
7	YES	YES
8	YES	YES
9	YES	YES
10	YES	YES
11	YES	YES
12	YES	YES
13	YES	YES
14	NO	YES
15	YES	YES
16	YES	YES
17	YES	YES
18	YES	YES
19	YES	YES
20	YES	YES
21	YES	YES
22	YES	YES
23	YES	YES
24	NO	YES
25	YES	YES
26	YES	YES
27	NO	YES
28	YES	YES
29	YES	YES
30	YES	YES
EUT Test Frequency:5310MHz Radar Frequency:5310MHz		

**Parameter Data sheet for Radar Type 1**

**5300MHz (20MHz Bandwidth)**

Radar Type1				
Trial #	Pulse Repetition Frequency Number(1 to 23)	Pulse Repetition Frequency (Pulses Per Second)	Number of Pulses	Pulse Repetition Interval (Microseconds)
1	3	1792.1	95	558
2	2	1858.7	99	538
3	9	1474.9	78	678
4	15	1253.1	67	798
5	21	1089.3	58	918
6	1	1930.5	102	518
7	10	1432.7	76	698
8	14	1285.3	68	778
9	16	1222.5	65	818
10	5	1672.2	89	598
11	4	1730.1	92	578
12	7	1567.4	83	638
13	19	1139.0	61	878
14	17	1193.3	63	838
15	20	1113.6	59	898
16	-	916.6	49	1091
17	-	425.0	23	2353
18	-	1049.3	56	953
19	-	838.9	45	1192
20	-	569.2	31	1757
21	-	612.7	33	1632
22	-	485.0	26	2062
23	-	1321.0	70	757
24	-	731.0	39	1368
25	-	888.9	47	1125
26	-	394.8	21	2533
27	-	1466.3	78	682
28	-	349.7	19	2860
29	-	889.7	47	1124
30	-	448.4	24	2230

**UL Japan, Inc.**

**Ise EMC Lab.**

4383-326 Asama-cho, Ise-shi, Mie-ken 516-0021 JAPAN

Telephone : +81 596 24 8999

Facsimile : +81 596 24 8124

**Parameter Data sheet for Radar Type 1**

**5310MHz (40MHz Bandwidth)**

Radar Type1				
Trial #	Pulse Repetition Frequency Number(1 to 23)	Pulse Repetition Frequency (Pulses Per Second)	Number of Pulses	Pulse Repetition Interval (Microseconds)
1	21	1089.3	58	918
2	6	1618.1	86	618
3	14	1285.3	68	778
4	7	1567.4	83	638
5	15	1253.1	67	798
6	3	1792.1	95	558
7	2	1858.7	99	538
8	4	1730.1	92	578
9	11	1392.8	74	718
10	10	1432.7	76	698
11	16	1222.5	65	818
12	23	326.2	18	3066
13	8	1519.8	81	658
14	12	1355.0	72	738
15	9	1474.9	78	678
16	-	481.0	26	2079
17	-	450.0	24	2222
18	-	1440.9	77	694
19	-	863.6	46	1158
20	-	386.8	21	2585
21	-	639.8	34	1563
22	-	637.3	34	1569
23	-	335.5	18	2981
24	-	1065.0	57	939
25	-	526.6	28	1899
26	-	535.6	29	1867
27	-	1124.9	60	889
28	-	648.9	35	1541
29	-	486.1	26	2057
30	-	404.9	22	2470

**UL Japan, Inc.**

**Ise EMC Lab.**

4383-326 Asama-cho, Ise-shi, Mie-ken 516-0021 JAPAN

Telephone : +81 596 24 8999

Facsimile : +81 596 24 8124

**Parameter Data sheet for Radar Type 5**

**5300MHz (20MHz Bandwidth)**

Trial #	Burst Number	Number of Pulses	Pulse Width [usec]	Chirp Width	Pulse 1-to-2 Spacing [usec]	Pulse 2-to-3 Spacing [usec]	Starting Location Within Interval [usec]	Center Frequency [MHz]
1	1	1	61	12			750	5300
	2	2	91	7	1378		48026	5300
	3	3	55	20	1061	1772	599080	5300
	4	2	58	15	1070		344082	5300
	5	1	70	10			639970	5300
	6	3	96	12	1800	1074	704434	5300
	7	1	71	9			352295	5300
	8	3	95	7	1810	1215	180503	5300
	9	3	63	16	1736	1335	493621	5300
	10	1	89	12			440679	5300
	11	1	72	10			791151	5300
	12	2	88	5	1121		190472	5300
	13	1	63	12			37682	5300
	14	2	92	8	1908		432633	5300

Trial #	Burst Number	Number of Pulses	Pulse Width [usec]	Chirp Width	Pulse 1-to-2 Spacing [usec]	Pulse 2-to-3 Spacing [usec]	Starting Location Within Interval [usec]	Center Frequency [MHz]
2	1	1	82	18			218	5300
	2	2	96	17	1298		107123	5300
	3	1	76	9			778517	5300
	4	2	92	19	1070		435502	5300
	5	3	55	14	1862	1343	343178	5300
	6	1	56	15			226975	5300
	7	2	82	12	1289		431877	5300
	8	2	95	14	1958		119075	5300
	9	3	62	6	1595	1378	422177	5300
	10	2	83	15	1127		745443	5300
	11	1	52	17			667561	5300
	12	1	58	10			282288	5300
	13	2	96	9	1017		226630	5300
	14	2	60	10	1140		389765	5300
	15	3	80	14	1674	1223	548004	5300

**UL Japan, Inc.**  
**Ise EMC Lab.**

4383-326 Asama-cho, Ise-shi, Mie-ken 516-0021 JAPAN  
Telephone : +81 596 24 8999  
Facsimile : +81 596 24 8124

Trial #	Burst Number	Number of Pulses	Pulse Width [usec]	Chirp Width	Pulse 1-to-2 Spacing [usec]	Pulse 2-to-3 Spacing [usec]	Starting Location Within Interval [usec]	Center Frequency [MHz]
3	1	2	64	20	1000		405943	5300
	2	1	62	18			329570	5300
	3	2	79	16	1498		513617	5300
	4	3	92	19	1588	1126	759562	5300
	5	2	75	19	1944		748435	5300
	6	2	68	17	1397		537788	5300
	7	3	69	20	1645	1159	6398	5300
	8	3	79	16	1949	1043	775049	5300
	9	3	96	19	1194	1987	148105	5300
	10	3	92	16	1149	1099	721912	5300
	11	1	57	11			113344	5300
	12	3	85	9	1875	1012	158107	5300
	13	3	84	16	1245	1957	571938	5300
	14	2	68	7	1119		51846	5300
	15	1	82	15			231945	5300

Trial #	Burst Number	Number of Pulses	Pulse Width [usec]	Chirp Width	Pulse 1-to-2 Spacing [usec]	Pulse 2-to-3 Spacing [usec]	Starting Location Within Interval [usec]	Center Frequency [MHz]
4	1	2	60	18	1000		158392	5300
	2	1	93	7			822776	5300
	3	2	53	20	1927		675795	5300
	4	2	73	18	1109		806569	5300
	5	1	83	11			105139	5300
	6	2	66	20	1921		504163	5300
	7	3	52	8	1229	1137	628807	5300
	8	3	67	16	1735	1506	580204	5300
	9	2	72	12	1274		526599	5300
	10	2	87	20	1270		97349	5300
	11	2	84	11	1318		224819	5300
	12	2	79	20	1378		235660	5300
	13	2	87	7	1728		617692	5300
	14	1	67	12			183780	5300

**UL Japan, Inc.**  
**Ise EMC Lab.**

4383-326 Asama-cho, Ise-shi, Mie-ken 516-0021 JAPAN  
Telephone : +81 596 24 8999  
Facsimile : +81 596 24 8124

Trial #	Burst Number	Number of Pulses	Pulse Width [usec]	Chirp Width	Pulse 1-to-2 Spacing [usec]	Pulse 2-to-3 Spacing [usec]	Starting Location Within Interval [usec]	Center Frequency [MHz]
5	1	2	89	17	1000		139197	5300
	2	3	84	13	1034	1546	875793	5300
	3	1	60	14			91402	5300
	4	1	68	17			387185	5300
	5	3	56	11	1327	1496	1056946	5300
	6	1	66	20			334650	5300
	7	3	78	20	1516	1107	965714	5300
	8	1	96	14			283072	5300
	9	3	61	15	1798	1808	962468	5300
	10	2	56	8	1140		1002259	5300

Trial #	Burst Number	Number of Pulses	Pulse Width [usec]	Chirp Width	Pulse 1-to-2 Spacing [usec]	Pulse 2-to-3 Spacing [usec]	Starting Location Within Interval [usec]	Center Frequency [MHz]
6	1	3	69	16	1287	1582	623021	5300
	2	1	79	18			142624	5300
	3	1	93	17			519544	5300
	4	3	50	20	1969	1454	93019	5300
	5	2	81	12	2000		302176	5300
	6	3	77	14	1414	1355	490580	5300
	7	1	96	11			584321	5300
	8	3	77	20	1992	1311	276486	5300
	9	2	63	5	1096		531792	5300
	10	2	61	18	1915		603253	5300
	11	1	55	9			731119	5300
	12	2	99	20	1411		728728	5300
	13	1	77	9			141613	5300
	14	2	68	18	1922		170743	5300
	15	1	88	20			98132	5300
	16	2	63	15	1625		648535	5300

**UL Japan, Inc.**  
**Ise EMC Lab.**

4383-326 Asama-cho, Ise-shi, Mie-ken 516-0021 JAPAN  
Telephone : +81 596 24 8999  
Facsimile : +81 596 24 8124

Trial #	Burst Number	Number of Pulses	Pulse Width [usec]	Chirp Width	Pulse 1-to-2 Spacing [usec]	Pulse 2-to-3 Spacing [usec]	Starting Location Within Interval [usec]	Center Frequency [MHz]
7	1	3	68	16	1155	1077	1015033	5300
	2	1	76	10			436586	5300
	3	1	69	20			890562	5300
	4	3	78	7	1879	1944	23317	5300
	5	2	80	8	1149		504927	5300
	6	2	56	16	1190		135605	5300
	7	3	68	20	1278	1944	52078	5300
	8	2	80	13	1023		1069464	5300
	9	1	86	10			681750	5300
	10	2	73	16	1218		186970	5300
	11	1	75	17			469371	5300

Trial #	Burst Number	Number of Pulses	Pulse Width [usec]	Chirp Width	Pulse 1-to-2 Spacing [usec]	Pulse 2-to-3 Spacing [usec]	Starting Location Within Interval [usec]	Center Frequency [MHz]
8	1	1	58	12			599	5300
	2	2	64	10	1366		453006	5300
	3	2	95	9	1942		709308	5300
	4	1	86	13			465769	5300
	5	2	72	14	1272		387302	5300
	6	3	55	13	1389	1815	359922	5300
	7	1	70	15			660734	5300
	8	1	62	7			667432	5300
	9	3	55	20	1411	1516	777093	5300
	10	1	61	12			17491	5300
	11	2	93	7	1362		400789	5300
	12	1	66	13			57616	5300
	13	1	59	6			186221	5300

**UL Japan, Inc.**

**Ise EMC Lab.**

4383-326 Asama-cho, Ise-shi, Mie-ken 516-0021 JAPAN

Telephone : +81 596 24 8999

Facsimile : +81 596 24 8124

Trial #	Burst Number	Number of Pulses	Pulse Width [usec]	Chirp Width	Pulse 1-to-2 Spacing [usec]	Pulse 2-to-3 Spacing [usec]	Starting Location Within Interval [usec]	Center Frequency [MHz]
9	1	3	67	5	1129	1101	661564	5300
	2	1	68	15			289553	5300
	3	2	89	6	1971		193511	5300
	4	2	62	12	1347		584939	5300
	5	2	88	5	1608		303869	5300
	6	3	80	6	1892	1463	296316	5300
	7	3	62	17	1054	1091	450330	5300
	8	1	96	15			695232	5300
	9	1	66	14			676981	5300
	10	3	90	10	1057	1735	315928	5300
	11	1	82	18			495302	5300
	12	1	75	15			427507	5300
	13	1	82	19			296153	5300

Trial #	Burst Number	Number of Pulses	Pulse Width [usec]	Chirp Width	Pulse 1-to-2 Spacing [usec]	Pulse 2-to-3 Spacing [usec]	Starting Location Within Interval [usec]	Center Frequency [MHz]
10	1	2	62	11	1000		250302	5300
	2	2	69	14	1024		66413	5300
	3	2	81	13	1753		28181	5300
	4	2	74	17	1759		650363	5300
	5	1	54	18			515383	5300
	6	2	84	13	1255		398076	5300
	7	3	56	5	1075	1359	7659	5300
	8	2	85	10	1276		481996	5300
	9	2	90	5	1985		474385	5300
	10	3	63	20	1435	1901	277052	5300
	11	1	84	15			632041	5300
	12	3	94	8	1992	1160	374717	5300
	13	2	69	8	1392		256378	5300
	14	1	76	6			254914	5300

**UL Japan, Inc.**  
**Ise EMC Lab.**

4383-326 Asama-cho, Ise-shi, Mie-ken 516-0021 JAPAN  
Telephone : +81 596 24 8999  
Facsimile : +81 596 24 8124

Trial #	Burst Number	Number of Pulses	Pulse Width [usec]	Chirp Width	Pulse 1-to-2 Spacing [usec]	Pulse 2-to-3 Spacing [usec]	Starting Location Within Interval [usec]	Center Frequency [MHz]
11	1	3	86	19	1647	1017	784161	5299
	2	3	93	8	1205	1878	1231913	5294
	3	3	96	7	1168	1980	1470270	5294
	4	3	96	6	1351	1522	1428842	5294
	5	2	54	11	1198		679037	5296
	6	2	87	8	1359		905916	5294
	7	2	92	9	1989		677762	5295
	8	2	53	14	1163		254006	5297

Trial #	Burst Number	Number of Pulses	Pulse Width [usec]	Chirp Width	Pulse 1-to-2 Spacing [usec]	Pulse 2-to-3 Spacing [usec]	Starting Location Within Interval [usec]	Center Frequency [MHz]
12	1	2	81	14	1000		47301	5297
	2	1	59	11			221676	5296
	3	3	57	16	1405	1563	531838	5298
	4	1	54	15			346095	5297
	5	1	51	7			87918	5294
	6	2	98	13	1554		40872	5296
	7	2	58	9	1471		410576	5295
	8	2	98	7	1749		136269	5294
	9	3	54	5	1411	1056	101703	5293
	10	3	91	7	1775	1307	162685	5294
	11	2	64	19	1043		474577	5299
	12	2	95	20	1671		284199	5299
	13	1	68	16			144395	5298
	14	1	74	7			441457	5294
	15	3	86	17	1793	1843	495762	5298
	16	3	76	6	1445	1374	517613	5294
	17	3	75	12	1186	1610	180262	5296
	18	3	89	15	1806	1361	316242	5297
	19	3	84	20	1517	1949	444265	5299
	20	1	55	12			244574	5296

**UL Japan, Inc.**  
**Ise EMC Lab.**

4383-326 Asama-cho, Ise-shi, Mie-ken 516-0021 JAPAN  
Telephone : +81 596 24 8999  
Facsimile : +81 596 24 8124

Trial #	Burst Number	Number of Pulses	Pulse Width [usec]	Chirp Width	Pulse 1-to-2 Spacing [usec]	Pulse 2-to-3 Spacing [usec]	Starting Location Within Interval [usec]	Center Frequency [MHz]
13	1	1	97	11			499	5296
	2	3	66	7	1908	1086	321822	5294
	3	2	80	8	1866		105619	5294
	4	1	93	12			249390	5296
	5	1	84	20			311308	5299
	6	1	83	14			546402	5297
	7	1	65	19			535195	5299
	8	1	71	11			678066	5296
	9	1	95	9			95467	5295
	10	3	62	19	1787	1587	171066	5299
	11	3	96	8	1987	1713	472368	5294
	12	3	100	10	1472	1232	682631	5295
	13	2	68	14	1288		131608	5297

Trial #	Burst Number	Number of Pulses	Pulse Width [usec]	Chirp Width	Pulse 1-to-2 Spacing [usec]	Pulse 2-to-3 Spacing [usec]	Starting Location Within Interval [usec]	Center Frequency [MHz]
14	1	1	78	19			81	5299
	2	1	71	10			829078	5295
	3	1	58	20			1000917	5299
	4	2	69	14	1192		1164886	5297
	5	2	70	5	1582		723311	5293
	6	2	90	13	1846		761840	5296
	7	2	59	18	1496		1132478	5298
	8	3	64	14	1775	1531	1012143	5297
	9	3	50	5	1181	1386	180574	5293
	10	1	68	10			470112	5295

**UL Japan, Inc.**  
**Ise EMC Lab.**

4383-326 Asama-cho, Ise-shi, Mie-ken 516-0021 JAPAN  
Telephone : +81 596 24 8999  
Facsimile : +81 596 24 8124

Trial #	Burst Number	Number of Pulses	Pulse Width [usec]	Chirp Width	Pulse 1-to-2 Spacing [usec]	Pulse 2-to-3 Spacing [usec]	Starting Location Within Interval [usec]	Center Frequency [MHz]
15	1	2	96	7	1000		911879	5294
	2	1	70	12			545087	5296
	3	3	75	18	1985	1608	802780	5298
	4	1	89	20			889721	5299
	5	1	59	13			912431	5296
	6	2	71	16	1573		548023	5298
	7	2	86	7	1124		1241708	5294
	8	3	60	16	1579	1959	159319	5298

Trial #	Burst Number	Number of Pulses	Pulse Width [usec]	Chirp Width	Pulse 1-to-2 Spacing [usec]	Pulse 2-to-3 Spacing [usec]	Starting Location Within Interval [usec]	Center Frequency [MHz]
16	1	2	57	17	1000		730863	5298
	2	2	99	15	1797		79971	5297
	3	2	76	11	1291		512824	5296
	4	3	94	14	1265	1984	306345	5297
	5	1	89	5			840583	5293
	6	2	77	16	1579		533943	5298
	7	1	52	17			70313	5298
	8	2	81	15	1269		62995	5297
	9	3	52	6	1006	1661	804683	5294
	10	1	77	16			637185	5298
	11	3	70	15	1140	1290	798926	5297
	12	2	67	19	1947		711082	5299
	13	2	64	8	1779		870875	5294

**UL Japan, Inc.**  
**Ise EMC Lab.**

4383-326 Asama-cho, Ise-shi, Mie-ken 516-0021 JAPAN  
Telephone : +81 596 24 8999  
Facsimile : +81 596 24 8124

Trial #	Burst Number	Number of Pulses	Pulse Width [usec]	Chirp Width	Pulse 1-to-2 Spacing [usec]	Pulse 2-to-3 Spacing [usec]	Starting Location Within Interval [usec]	Center Frequency [MHz]
17	1	2	91	10	1000		420179	5295
	2	1	71	19			348389	5299
	3	3	62	15	1214	1026	523473	5297
	4	1	96	11			203904	5296
	5	1	82	16			482486	5298
	6	1	91	17			98827	5298
	7	1	77	19			592421	5299
	8	2	56	7	1956		618308	5294
	9	2	54	7	1835		586580	5294
	10	1	54	17			191496	5298
	11	1	70	10			79357	5295
	12	3	58	16	1685	1699	397916	5298
	13	2	66	15	1556		360743	5297
	14	2	57	19	1585		567207	5299
	15	3	58	16	1465	1179	486580	5298
	16	2	58	17	1020		631941	5298

Trial #	Burst Number	Number of Pulses	Pulse Width [usec]	Chirp Width	Pulse 1-to-2 Spacing [usec]	Pulse 2-to-3 Spacing [usec]	Starting Location Within Interval [usec]	Center Frequency [MHz]
18	1	2	67	13	1000		398851	5296
	2	3	95	20	1045	1868	378141	5299
	3	3	50	9	1339	1170	357392	5295
	4	1	91	10			541844	5295
	5	1	72	12			464211	5296
	6	3	56	19	1016	1324	214194	5299
	7	1	66	9			17782	5295
	8	2	68	7	1097		346593	5294
	9	3	58	18	1596	1860	469747	5298
	10	2	57	19	1511		159358	5299
	11	1	68	5			243967	5293
	12	3	67	9	1468	1458	524176	5295
	13	2	91	13	1217		327487	5296
	14	3	85	8	1483	1370	234369	5294
	15	3	67	10	1529	1110	94531	5295
	16	3	67	11	1994	1852	326111	5296
	17	3	87	8	1038	1656	284052	5294
	18	1	73	20			493727	5299

**UL Japan, Inc.**  
**Ise EMC Lab.**

4383-326 Asama-cho, Ise-shi, Mie-ken 516-0021 JAPAN  
Telephone : +81 596 24 8999  
Facsimile : +81 596 24 8124

Trial #	Burst Number	Number of Pulses	Pulse Width [usec]	Chirp Width	Pulse 1-to-2 Spacing [usec]	Pulse 2-to-3 Spacing [usec]	Starting Location Within Interval [usec]	Center Frequency [MHz]
19	1	3	92	15	1154	1949	391303	5297
	2	3	90	14	1923	1690	201670	5297
	3	3	58	15	1495	1939	549444	5297
	4	1	88	6			332660	5294
	5	2	67	5	1641		599516	5293
	6	2	60	12	1351		14387	5296
	7	2	82	19	1490		385479	5299
	8	1	66	20			524897	5299
	9	3	98	14	1683	1715	515942	5297
	10	1	98	13			113493	5296
	11	1	59	20			60018	5299
	12	2	100	7	1111		47164	5294
	13	3	89	19	1613	1969	328553	5299
	14	1	59	17			518980	5298
	15	2	51	8	1895		551676	5294
	16	2	67	16	1207		368282	5298
	17	1	80	14			502662	5297
	18	2	60	17	1503		234909	5298
	19	1	89	12			92415	5296

Trial #	Burst Number	Number of Pulses	Pulse Width [usec]	Chirp Width	Pulse 1-to-2 Spacing [usec]	Pulse 2-to-3 Spacing [usec]	Starting Location Within Interval [usec]	Center Frequency [MHz]
20	1	3	85	14	1406	1478	1246808	5297
	2	3	92	11	1439	1139	1314064	5296
	3	1	60	20			1257031	5299
	4	2	98	9	1970		190078	5295
	5	2	100	16	1399		1190594	5298
	6	1	82	13			607665	5296
	7	2	78	6	1027		575659	5294
	8	2	51	16	1516		14264	5298
	9	3	87	15	1600	1308	378946	5297

**UL Japan, Inc.**  
**Ise EMC Lab.**

4383-326 Asama-cho, Ise-shi, Mie-ken 516-0021 JAPAN  
Telephone : +81 596 24 8999  
Facsimile : +81 596 24 8124

Trial #	Burst Number	Number of Pulses	Pulse Width [usec]	Chirp Width	Pulse 1-to-2 Spacing [usec]	Pulse 2-to-3 Spacing [usec]	Starting Location Within Interval [usec]	Center Frequency [MHz]
21	1	3	55	19	1251	1023	339102	5301
	2	3	94	20	1642	1458	443778	5301
	3	2	90	15	1392		936899	5303
	4	3	64	13	1705	1547	129856	5304
	5	3	97	12	1174	1829	529593	5304
	6	3	99	17	1885	1962	56954	5302
	7	3	96	11	1747	1276	340713	5304
	8	3	90	7	1693	1687	954979	5306
	9	1	68	7			631673	5306
	10	3	74	7	1944	1460	743676	5306
	11	3	82	20	1697	1701	659084	5301
	12	1	67	16			548548	5302

Trial #	Burst Number	Number of Pulses	Pulse Width [usec]	Chirp Width	Pulse 1-to-2 Spacing [usec]	Pulse 2-to-3 Spacing [usec]	Starting Location Within Interval [usec]	Center Frequency [MHz]
22	1	3	67	18	1745	1114	725998	5302
	2	3	54	19	1313	1133	439044	5301
	3	3	67	11	1597	1848	380423	5304
	4	3	81	16	1935	1841	276203	5302
	5	3	81	14	1854	1119	758409	5303
	6	2	52	19	1631		805691	5301
	7	3	91	8	1854	1032	794809	5306
	8	3	65	16	1558	1337	316670	5302
	9	3	76	18	1003	1723	822588	5302
	10	1	93	20			540638	5301
	11	1	66	19			494293	5301
	12	3	52	10	1787	1708	324736	5305
	13	1	92	15			671168	5303
	14	2	56	19	1810		629648	5301

**UL Japan, Inc.**  
**Ise EMC Lab.**

4383-326 Asama-cho, Ise-shi, Mie-ken 516-0021 JAPAN  
Telephone : +81 596 24 8999  
Facsimile : +81 596 24 8124

Trial #	Burst Number	Number of Pulses	Pulse Width [usec]	Chirp Width	Pulse 1-to-2 Spacing [usec]	Pulse 2-to-3 Spacing [usec]	Starting Location Within Interval [usec]	Center Frequency [MHz]
23	1	2	70	20	1000		440502	5301
	2	2	68	8	1072		19600	5306
	3	1	51	5			13049	5307
	4	3	81	15	1044	1895	412085	5303
	5	2	50	19	1744		503075	5301
	6	1	75	9			361265	5305
	7	3	52	6	1186	1778	284592	5306
	8	1	78	6			182345	5306
	9	2	77	9	1480		564237	5305
	10	1	57	6			21663	5306
	11	2	95	5	1541		135882	5307
	12	2	50	18	1106		550021	5302
	13	2	91	14	1208		239983	5303
	14	3	72	18	1193	1870	551028	5302
	15	1	74	5			201689	5307
	16	2	75	18	1982		207102	5302
	17	3	91	12	1936	1961	183560	5304
	18	3	92	14	1181	1478	173416	5303
	19	1	89	6			475127	5306
	20	3	80	12	1633	1273	151614	5304

Trial #	Burst Number	Number of Pulses	Pulse Width [usec]	Chirp Width	Pulse 1-to-2 Spacing [usec]	Pulse 2-to-3 Spacing [usec]	Starting Location Within Interval [usec]	Center Frequency [MHz]
24	1	3	72	10	1860	1552	997971	5305
	2	1	90	10			239805	5305
	3	3	52	5	1135	1159	519059	5307
	4	3	90	10	1611	1053	1011723	5305
	5	3	88	17	1180	1468	577712	5302
	6	1	72	9			48322	5305
	7	2	71	17	1097		757448	5302
	8	2	57	15	1048		353619	5303
	9	2	60	17	1665		24782	5302
	10	2	91	6	1197		773989	5306
	11	1	62	19			495448	5301

**UL Japan, Inc.**  
**Ise EMC Lab.**

4383-326 Asama-cho, Ise-shi, Mie-ken 516-0021 JAPAN  
Telephone : +81 596 24 8999  
Facsimile : +81 596 24 8124

Trial #	Burst Number	Number of Pulses	Pulse Width [usec]	Chirp Width	Pulse 1-to-2 Spacing [usec]	Pulse 2-to-3 Spacing [usec]	Starting Location Within Interval [usec]	Center Frequency [MHz]
25	1	1	60	10			294	5305
	2	3	65	5	1563	1740	452908	5307
	3	3	77	13	1520	1959	237217	5304
	4	3	86	10	1449	1461	121394	5305
	5	2	51	16	1190		436733	5302
	6	2	94	9	1168		78316	5305
	7	3	65	6	1734	1397	147071	5306
	8	3	68	9	1709	1129	530734	5305
	9	3	74	9	1210	1237	63635	5305
	10	3	83	19	1261	1997	449314	5301
	11	1	70	6			494861	5306
	12	1	71	12			139234	5304
	13	1	67	16			238444	5302
	14	1	72	12			275247	5304
	15	3	81	7	1764	1457	527655	5306
	16	2	76	15	1014		223586	5303
	17	2	63	13	1937		15827	5304
	18	2	57	15	1451		463597	5303
	19	3	93	10	1690	1167	524388	5305
	20	1	99	15			586711	5303

Trial #	Burst Number	Number of Pulses	Pulse Width [usec]	Chirp Width	Pulse 1-to-2 Spacing [usec]	Pulse 2-to-3 Spacing [usec]	Starting Location Within Interval [usec]	Center Frequency [MHz]
26	1	3	55	10	1498	1331	707845	5305
	2	1	91	17			420216	5302
	3	2	83	14	1882		307327	5303
	4	1	82	19			378323	5301
	5	1	80	16			938618	5302
	6	2	89	12	1858		401130	5304
	7	2	72	18	1702		613010	5302
	8	1	77	13			992455	5304
	9	3	86	19	1340	1113	390273	5301
	10	3	83	12	1553	1989	217203	5304

**UL Japan, Inc.**  
**Ise EMC Lab.**

4383-326 Asama-cho, Ise-shi, Mie-ken 516-0021 JAPAN  
Telephone : +81 596 24 8999  
Facsimile : +81 596 24 8124

Trial #	Burst Number	Number of Pulses	Pulse Width [usec]	Chirp Width	Pulse 1-to-2 Spacing [usec]	Pulse 2-to-3 Spacing [usec]	Starting Location Within Interval [usec]	Center Frequency [MHz]
27	1	1	99	15			284	5303
	2	3	74	11	1911	1987	936473	5304
	3	2	97	14	1435		319093	5303
	4	2	61	10	1907		1112104	5305
	5	3	83	20	1264	1225	131821	5301
	6	1	51	6			351420	5306
	7	3	69	7	1061	1832	848090	5306
	8	1	57	18			319615	5302
	9	3	64	19	1113	1761	460842	5301

Trial #	Burst Number	Number of Pulses	Pulse Width [usec]	Chirp Width	Pulse 1-to-2 Spacing [usec]	Pulse 2-to-3 Spacing [usec]	Starting Location Within Interval [usec]	Center Frequency [MHz]
28	1	3	58	20	1173	1716	321784	5301
	2	2	57	17	1268		697202	5302
	3	3	58	16	1945	1605	235039	5302
	4	1	58	8			632320	5306
	5	3	83	17	1785	1602	661553	5302
	6	1	80	15			607014	5303
	7	1	68	11			496640	5304
	8	3	82	10	1431	1738	543181	5305
	9	1	52	11			230059	5304
	10	3	72	12	1816	1738	419053	5304
	11	3	98	5	1267	1207	8455	5307
	12	1	70	12			859663	5304
	13	1	85	16			92738	5302

**UL Japan, Inc.**  
**Ise EMC Lab.**

4383-326 Asama-cho, Ise-shi, Mie-ken 516-0021 JAPAN  
Telephone : +81 596 24 8999  
Facsimile : +81 596 24 8124

Trial #	Burst Number	Number of Pulses	Pulse Width [usec]	Chirp Width	Pulse 1-to-2 Spacing [usec]	Pulse 2-to-3 Spacing [usec]	Starting Location Within Interval [usec]	Center Frequency [MHz]
29	1	3	56	13	1758	1162	797476	5304
	2	1	80	12			425366	5304
	3	2	99	14	1463		1097251	5303
	4	2	95	11	1396		139789	5304
	5	2	70	5	1352		715600	5307
	6	3	82	16	1454	1155	1453713	5302
	7	1	90	12			1039321	5304
	8	3	82	13	1683	1022	1118154	5304

Trial #	Burst Number	Number of Pulses	Pulse Width [usec]	Chirp Width	Pulse 1-to-2 Spacing [usec]	Pulse 2-to-3 Spacing [usec]	Starting Location Within Interval [usec]	Center Frequency [MHz]
30	1	2	55	14	1000		598840	5303
	2	3	67	20	1808	1134	523187	5301
	3	3	95	20	1936	1307	556733	5301
	4	2	61	12	1000		370177	5304
	5	2	83	15	1970		46954	5303
	6	2	54	15	1068		374096	5303
	7	2	58	7	1694		458473	5306
	8	1	82	19			103777	5301
	9	2	52	12	1464		642061	5304
	10	3	66	9	1814	1051	20764	5305
	11	3	81	20	1244	1244	27585	5301
	12	2	71	5	1373		426123	5307
	13	3	81	20	1678	1896	621619	5301
	14	1	58	7			435293	5306
	15	3	92	10	1962	1602	355013	5305
	16	2	93	14	1407		515660	5303
	17	1	91	8			445259	5306
	18	3	69	10	1905	1265	473468	5305

**UL Japan, Inc.**  
**Ise EMC Lab.**

4383-326 Asama-cho, Ise-shi, Mie-ken 516-0021 JAPAN  
Telephone : +81 596 24 8999  
Facsimile : +81 596 24 8124

**Parameter Data sheet for Radar Type 5**

**5310MHz (40MHz Bandwidth)**

Trial #	Burst Number	Number of Pulses	Pulse Width [usec]	Chirp Width	Pulse 1-to-2 Spacing [usec]	Pulse 2-to-3 Spacing [usec]	Starting Location Within Interval [usec]	Center Frequency [MHz]
1	1	3	56	13	1484	1321	646023	5310
	2	2	52	20	1456		500181	5310
	3	1	94	8			570743	5310
	4	1	91	12			318158	5310
	5	3	54	13	1904	1506	156501	5310
	6	2	99	8	1959		95198	5310
	7	1	64	18			209852	5310
	8	1	73	20			259316	5310
	9	1	56	10			265789	5310
	10	2	75	5	1859		483447	5310
	11	1	55	12			192129	5310
	12	1	81	16			444429	5310
	13	1	58	18			418809	5310
	14	1	72	6			83655	5310
	15	2	94	19	1117		365919	5310
	16	2	72	19	1321		127051	5310
	17	2	93	12	1798		54264	5310
	18	3	67	15	1178	1549	487757	5310

Trial #	Burst Number	Number of Pulses	Pulse Width [usec]	Chirp Width	Pulse 1-to-2 Spacing [usec]	Pulse 2-to-3 Spacing [usec]	Starting Location Within Interval [usec]	Center Frequency [MHz]
2	1	1	53	6			224	5310
	2	3	94	10	1448	1781	472625	5310
	3	1	77	11			265299	5310
	4	3	96	11	1509	1930	447910	5310
	5	1	86	17			725704	5310
	6	3	56	16	1313	1657	257782	5310
	7	3	74	19	1254	1723	141758	5310
	8	3	83	14	1847	1581	484257	5310
	9	3	89	18	1351	1960	638721	5310
	10	2	70	11	1715		713039	5310
	11	2	56	20	1606		441011	5310
	12	2	52	17	1066		239876	5310
	13	1	56	14			503484	5310
	14	3	90	5	1412	1039	131105	5310
	15	3	52	14	1626	1268	205821	5310
	16	2	75	15	1618		206463	5310

**UL Japan, Inc.**  
**Ise EMC Lab.**

4383-326 Asama-cho, Ise-shi, Mie-ken 516-0021 JAPAN  
Telephone : +81 596 24 8999  
Facsimile : +81 596 24 8124

Trial #	Burst Number	Number of Pulses	Pulse Width [usec]	Chirp Width	Pulse 1-to-2 Spacing [usec]	Pulse 2-to-3 Spacing [usec]	Starting Location Within Interval [usec]	Center Frequency [MHz]
3	1	3	70	19	1578	1129	237486	5310
	2	1	50	19			666775	5310
	3	3	69	13	1543	1668	700443	5310
	4	1	84	6			261964	5310
	5	3	54	9	1282	1124	750084	5310
	6	2	51	18	1048		731459	5310
	7	3	78	11	1233	1090	251403	5310
	8	1	96	20			454066	5310
	9	1	83	15			518283	5310
	10	3	51	7	1633	1541	430584	5310
	11	1	53	16			60545	5310
	12	2	58	17	1042		447625	5310
	13	2	58	18	1158		56736	5310
	14	3	74	14	1823	1295	324694	5310
	15	1	98	6			222452	5310

Trial #	Burst Number	Number of Pulses	Pulse Width [usec]	Chirp Width	Pulse 1-to-2 Spacing [usec]	Pulse 2-to-3 Spacing [usec]	Starting Location Within Interval [usec]	Center Frequency [MHz]
4	1	2	61	19	1000		93755	5310
	2	3	70	5	1994	1027	16000	5310
	3	1	70	16			558054	5310
	4	1	70	11			85038	5310
	5	3	55	5	1057	2000	30339	5310
	6	1	59	16			463509	5310
	7	3	85	6	1739	1832	601545	5310
	8	3	64	20	1375	1213	194023	5310
	9	3	66	18	1466	1946	478849	5310
	10	2	81	19	1764		613525	5310
	11	1	56	20			578235	5310
	12	3	77	8	1226	1061	336557	5310
	13	2	80	10	1952		61456	5310
	14	2	93	17	1432		170753	5310
	15	1	83	8			651221	5310
	16	1	62	11			457935	5310
	17	3	83	9	1948	1077	32240	5310
	18	1	99	7			342082	5310

**UL Japan, Inc.**  
**Ise EMC Lab.**

4383-326 Asama-cho, Ise-shi, Mie-ken 516-0021 JAPAN  
Telephone : +81 596 24 8999  
Facsimile : +81 596 24 8124

Trial #	Burst Number	Number of Pulses	Pulse Width [usec]	Chirp Width	Pulse 1-to-2 Spacing [usec]	Pulse 2-to-3 Spacing [usec]	Starting Location Within Interval [usec]	Center Frequency[MHz]
5	1	2	98	7	1000		546539	5310
	2	1	87	10			1342480	5310
	3	3	56	17	1583	1987	1463814	5310
	4	3	95	5	1588	1332	609253	5310
	5	2	88	7	1229		130154	5310
	6	1	64	17			1444170	5310
	7	2	93	7	1904		882935	5310
	8	1	72	16			141832	5310

Trial #	Burst Number	Number of Pulses	Pulse Width [usec]	Chirp Width	Pulse 1-to-2 Spacing [usec]	Pulse 2-to-3 Spacing [usec]	Starting Location Within Interval [usec]	Center Frequency[MHz]
6	1	2	55	15	1000		215380	5310
	2	1	74	16			204067	5310
	3	1	65	6			111004	5310
	4	3	80	8	1660	1436	408552	5310
	5	1	84	15			508887	5310
	6	1	62	18			768363	5310
	7	2	84	10	1514		637129	5310
	8	2	66	16	1387		20544	5310
	9	1	98	7			149755	5310
	10	1	64	10			17411	5310
	11	1	75	12			343020	5310
	12	2	95	6	1960		573669	5310
	13	2	90	7	1043		359631	5310
	14	1	77	12			336366	5310
	15	3	94	12	1604	1829	73975	5310

**UL Japan, Inc.**  
**Ise EMC Lab.**

4383-326 Asama-cho, Ise-shi, Mie-ken 516-0021 JAPAN  
Telephone : +81 596 24 8999  
Facsimile : +81 596 24 8124

Trial #	Burst Number	Number of Pulses	Pulse Width [usec]	Chirp Width	Pulse 1-to-2 Spacing [usec]	Pulse 2-to-3 Spacing [usec]	Starting Location Within Interval [usec]	Center Frequency[MHz]
7	1	1	63	15			693	5310
	2	2	92	16	1443		416173	5310
	3	1	62	13			73925	5310
	4	2	86	15	1122		1064144	5310
	5	3	56	12	1604	1217	491259	5310
	6	3	52	8	1579	1469	222275	5310
	7	1	71	15			139270	5310
	8	3	95	15	1578	1541	270426	5310
	9	3	99	8	1824	1917	419095	5310
	10	1	59	17			941580	5310
	11	1	93	11			514357	5310

Trial #	Burst Number	Number of Pulses	Pulse Width [usec]	Chirp Width	Pulse 1-to-2 Spacing [usec]	Pulse 2-to-3 Spacing [usec]	Starting Location Within Interval [usec]	Center Frequency[MHz]
8	1	2	61	8	1000		1080713	5310
	2	1	55	18			88817	5310
	3	2	71	7	1554		901462	5310
	4	1	78	9			771692	5310
	5	1	79	20			1250556	5310
	6	3	60	5	1296	1463	490373	5310
	7	3	72	16	1790	1442	469541	5310
	8	2	64	12	1757		613893	5310
	9	2	62	6	1113		392619	5310

**UL Japan, Inc.**  
**Ise EMC Lab.**

4383-326 Asama-cho, Ise-shi, Mie-ken 516-0021 JAPAN  
Telephone : +81 596 24 8999  
Facsimile : +81 596 24 8124

Trial #	Burst Number	Number of Pulses	Pulse Width [usec]	Chirp Width	Pulse 1-to-2 Spacing [usec]	Pulse 2-to-3 Spacing [usec]	Starting Location Within Interval [usec]	Center Frequency[MHz]
9	1	1	98	18			39	5310
	2	2	92	11	1270		1218548	5310
	3	3	72	16	1261	1975	764761	5310
	4	3	70	6	1593	1090	740446	5310
	5	1	51	6			250783	5310
	6	2	51	15	1537		54017	5310
	7	1	75	20			1336179	5310
	8	1	83	6			1250411	5310

Trial #	Burst Number	Number of Pulses	Pulse Width [usec]	Chirp Width	Pulse 1-to-2 Spacing [usec]	Pulse 2-to-3 Spacing [usec]	Starting Location Within Interval [usec]	Center Frequency[MHz]
10	1	3	77	14	1959	1439	496544	5310
	2	3	98	10	1613	1736	495566	5310
	3	3	80	10	1826	1247	790360	5310
	4	2	55	12	1011		1293490	5310
	5	3	100	12	1520	1906	176516	5310
	6	2	52	12	1576		374318	5310
	7	2	93	14	1108		424987	5310
	8	1	53	8			735226	5310
	9	2	80	8	1799		472068	5310

**UL Japan, Inc.**  
**Ise EMC Lab.**

4383-326 Asama-cho, Ise-shi, Mie-ken 516-0021 JAPAN  
Telephone : +81 596 24 8999  
Facsimile : +81 596 24 8124

Trial #	Burst Number	Number of Pulses	Pulse Width [usec]	Chirp Width	Pulse 1-to-2 Spacing [usec]	Pulse 2-to-3 Spacing [usec]	Starting Location Within Interval [usec]	Center Frequency [MHz]
11	1	2	64	11	1000		605321	5296
	2	2	62	9	1261		419349	5295
	3	1	80	5			202852	5294
	4	3	88	7	1009	1219	479385	5295
	5	2	94	5	1657		327076	5294
	6	3	92	10	1436	1728	674472	5296
	7	1	64	15			430023	5298
	8	2	76	10	1019		478710	5296
	9	1	94	15			366723	5298
	10	3	73	11	1211	1909	24565	5296
	11	1	77	14			383120	5297
	12	2	74	11	1403		566422	5296
	13	3	58	11	1256	1122	70248	5296
	14	2	91	11	1006		267925	5296
	15	1	92	13			328211	5297
	16	2	69	6	1721		569500	5294

Trial #	Burst Number	Number of Pulses	Pulse Width [usec]	Chirp Width	Pulse 1-to-2 Spacing [usec]	Pulse 2-to-3 Spacing [usec]	Starting Location Within Interval [usec]	Center Frequency [MHz]
12	1	2	56	11	1000		742949	5296
	2	3	81	15	1420	1784	284187	5298
	3	2	94	12	1150		285988	5297
	4	3	51	5	1278	1903	364352	5294
	5	3	82	17	1897	1731	348544	5299
	6	3	89	18	1049	1759	575999	5299
	7	1	53	12			817527	5297
	8	2	63	17	1606		952873	5299
	9	3	87	14	1401	1656	374829	5297
	10	2	51	20	1430		596962	5300
	11	1	73	7			148698	5295

**UL Japan, Inc.**  
**Ise EMC Lab.**

4383-326 Asama-cho, Ise-shi, Mie-ken 516-0021 JAPAN  
Telephone : +81 596 24 8999  
Facsimile : +81 596 24 8124

Trial #	Burst Number	Number of Pulses	Pulse Width [usec]	Chirp Width	Pulse 1-to-2 Spacing [usec]	Pulse 2-to-3 Spacing [usec]	Starting Location Within Interval [usec]	Center Frequency [MHz]
13	1	3	57	8	1298	1590	1157084	5295
	2	3	88	8	1104	1890	1018967	5295
	3	1	79	11			811132	5296
	4	3	64	11	1633	1245	437344	5296
	5	3	57	6	1739	1735	1158590	5294
	6	2	96	17	1463		1224313	5299
	7	2	84	20	1587		1040926	5300
	8	3	96	12	1328	1982	1272846	5297
	9	1	75	17			685734	5299

Trial #	Burst Number	Number of Pulses	Pulse Width [usec]	Chirp Width	Pulse 1-to-2 Spacing [usec]	Pulse 2-to-3 Spacing [usec]	Starting Location Within Interval [usec]	Center Frequency [MHz]
14	1	1	75	12			706	5297
	2	2	61	15	1072		178693	5298
	3	3	73	20	1598	1113	598174	5300
	4	1	95	7			103908	5295
	5	1	52	20			559348	5300
	6	1	57	6			161921	5294
	7	1	50	7			343418	5295
	8	1	96	15			571580	5298
	9	1	56	5			692411	5294
	10	2	73	15	1144		630726	5298
	11	3	74	8	1885	1792	70339	5295
	12	2	87	13	1967		491202	5297
	13	3	61	11	1810	1345	245913	5296
	14	3	69	9	1236	1993	439653	5295
	15	3	91	14	1361	1115	398454	5297
	16	3	52	8	1177	1740	540712	5295

**UL Japan, Inc.**  
**Ise EMC Lab.**

4383-326 Asama-cho, Ise-shi, Mie-ken 516-0021 JAPAN  
Telephone : +81 596 24 8999  
Facsimile : +81 596 24 8124

Trial #	Burst Number	Number of Pulses	Pulse Width [usec]	Chirp Width	Pulse 1-to-2 Spacing [usec]	Pulse 2-to-3 Spacing [usec]	Starting Location Within Interval [usec]	Center Frequency [MHz]
15	1	2	66	13	1000		729282	5297
	2	2	94	18	1707		775139	5299
	3	1	73	10			576364	5296
	4	2	66	6	1988		549405	5294
	5	1	92	8			563013	5295
	6	2	52	20	1364		101300	5300
	7	2	87	11	1187		144648	5296
	8	1	85	12			624576	5297
	9	1	57	6			655414	5294
	10	2	66	17	1706		379501	5299
	11	2	95	12	1622		186423	5297
	12	2	55	17	1381		725653	5299

Trial #	Burst Number	Number of Pulses	Pulse Width [usec]	Chirp Width	Pulse 1-to-2 Spacing [usec]	Pulse 2-to-3 Spacing [usec]	Starting Location Within Interval [usec]	Center Frequency [MHz]
16	1	3	97	5	1202	1224	187491	5294
	2	1	65	5			153934	5294
	3	2	80	11	1178		411254	5296
	4	1	64	8			508594	5295
	5	3	67	11	1240	1879	334476	5296
	6	3	75	5	1803	1931	246611	5294
	7	2	62	16	1713		818563	5298
	8	2	68	17	1892		621114	5299
	9	1	55	13			238930	5297

**UL Japan, Inc.**  
**Ise EMC Lab.**

4383-326 Asama-cho, Ise-shi, Mie-ken 516-0021 JAPAN  
Telephone : +81 596 24 8999  
Facsimile : +81 596 24 8124

Trial #	Burst Number	Number of Pulses	Pulse Width [usec]	Chirp Width	Pulse 1-to-2 Spacing [usec]	Pulse 2-to-3 Spacing [usec]	Starting Location Within Interval [usec]	Center Frequency [MHz]
17	1	2	59	11	1000		112691	5296
	2	3	66	17	1880	1243	549982	5299
	3	3	70	7	1220	1393	396750	5295
	4	2	91	18	1895		240058	5299
	5	2	95	18	1068		646329	5299
	6	1	57	5			6377	5294
	7	1	92	12			278154	5297
	8	3	62	13	1804	1463	275287	5297
	9	1	54	18			139794	5299
	10	2	79	5	1718		254683	5294
	11	3	74	8	1484	1418	18377	5295
	12	2	92	18	1476		64990	5299
	13	3	98	15	1109	1097	464286	5298
	14	2	72	9	1855		282634	5295
	15	2	72	12	1991		79860	5297
	16	3	82	13	1431	1764	391013	5297
	17	1	72	15			183221	5298
	18	2	58	11	1727		316729	5296

Trial #	Burst Number	Number of Pulses	Pulse Width [usec]	Chirp Width	Pulse 1-to-2 Spacing [usec]	Pulse 2-to-3 Spacing [usec]	Starting Location Within Interval [usec]	Center Frequency [MHz]
18	1	2	67	19	1000		36628	5299
	2	2	93	20	1377		603168	5300
	3	3	66	18	1959	1960	583151	5299
	4	3	58	16	1453	1292	722581	5298
	5	3	87	18	1579	1256	771224	5299
	6	3	71	14	1267	1778	744615	5297
	7	1	98	16			218337	5298
	8	2	85	16	1154		318232	5298
	9	2	99	17	1256		537510	5299
	10	2	89	14	1646		484187	5297
	11	2	57	11	1439		176970	5296
	12	1	88	5			195	5294
	13	3	84	7	1785	1887	337766	5295
	14	3	62	16	1585	1097	270750	5298
	15	2	69	16	1475		89020	5298

**UL Japan, Inc.**  
**Ise EMC Lab.**

4383-326 Asama-cho, Ise-shi, Mie-ken 516-0021 JAPAN  
Telephone : +81 596 24 8999  
Facsimile : +81 596 24 8124

Trial #	Burst Number	Number of Pulses	Pulse Width [usec]	Chirp Width	Pulse 1-to-2 Spacing [usec]	Pulse 2-to-3 Spacing [usec]	Starting Location Within Interval [usec]	Center Frequency [MHz]
19	1	3	64	13	1990	1197	86287	5297
	2	2	69	9	1055		536458	5295
	3	2	59	9	1169		395357	5295
	4	2	60	16	1451		928928	5298
	5	3	59	10	1654	1032	76966	5296
	6	3	80	17	1695	1949	1159336	5299
	7	1	84	7			410147	5295
	8	2	80	10	1722		271347	5296
	9	3	58	19	1736	1728	1060237	5299
	10	3	60	15	1989	1701	29055	5298

Trial #	Burst Number	Number of Pulses	Pulse Width [usec]	Chirp Width	Pulse 1-to-2 Spacing [usec]	Pulse 2-to-3 Spacing [usec]	Starting Location Within Interval [usec]	Center Frequency [MHz]
20	1	1	68	10			362	5296
	2	2	95	17	1227		24631	5299
	3	3	57	14	1993	1382	107383	5297
	4	3	65	8	1733	1165	114400	5295
	5	3	72	12	1976	1616	62459	5297
	6	3	51	16	1298	1271	128380	5298
	7	3	75	17	1131	1854	214092	5299
	8	1	82	20			524590	5300
	9	1	68	15			411627	5298
	10	1	56	7			304060	5295
	11	3	77	17	1761	1584	529662	5299
	12	2	82	13	1161		150868	5297
	13	3	60	19	1144	1534	569909	5299
	14	2	80	10	1555		326083	5296
	15	2	57	11	1520		42623	5296
	16	3	71	5	1399	1779	143712	5294
	17	2	74	12	1911		365622	5297
	18	2	81	10	1209		513011	5296
	19	2	76	8	1397		37220	5295
	20	3	81	13	1382	1249	277524	5297

**UL Japan, Inc.**  
**Ise EMC Lab.**

4383-326 Asama-cho, Ise-shi, Mie-ken 516-0021 JAPAN  
Telephone : +81 596 24 8999  
Facsimile : +81 596 24 8124

Trial #	Burst Number	Number of Pulses	Pulse Width [usec]	Chirp Width	Pulse 1-to-2 Spacing [usec]	Pulse 2-to-3 Spacing [usec]	Starting Location Within Interval [usec]	Center Frequency [MHz]
21	1	3	62	16	1198	1199	104965	5322
	2	3	76	16	1585	1014	249648	5322
	3	2	64	8	1646		616141	5325
	4	1	97	9			262256	5325
	5	1	92	12			146884	5323
	6	2	72	11	1743		716802	5324
	7	2	68	11	1611		315556	5324
	8	2	61	19	1490		131198	5321
	9	2	60	6	1219		964635	5326
	10	1	97	12			596483	5323
	11	3	52	18	1132	1526	824109	5321

Trial #	Burst Number	Number of Pulses	Pulse Width [usec]	Chirp Width	Pulse 1-to-2 Spacing [usec]	Pulse 2-to-3 Spacing [usec]	Starting Location Within Interval [usec]	Center Frequency [MHz]
22	1	2	60	16	1000		1008216	5322
	2	3	75	12	1340	1860	470962	5323
	3	3	73	19	1620	1692	1235330	5321
	4	2	92	9	1137		995855	5325
	5	1	84	16			726921	5322
	6	3	83	14	1791	1409	632983	5323
	7	1	89	9			169877	5325
	8	1	93	11			62128	5324
	9	3	73	11	1331	1782	206602	5324

**UL Japan, Inc.**

**Ise EMC Lab.**

4383-326 Asama-cho, Ise-shi, Mie-ken 516-0021 JAPAN

Telephone : +81 596 24 8999

Facsimile : +81 596 24 8124

Trial #	Burst Number	Number of Pulses	Pulse Width [usec]	Chirp Width	Pulse 1-to-2 Spacing [usec]	Pulse 2-to-3 Spacing [usec]	Starting Location Within Interval [usec]	Center Frequency [MHz]
23	1	1	99	11			116	5324
	2	2	100	6	1878		576577	5326
	3	2	83	10	1680		226191	5324
	4	3	76	10	1807	1352	678266	5324
	5	1	84	8			62748	5325
	6	3	82	14	1089	1527	351654	5323
	7	1	60	19			666537	5321
	8	1	84	10			412245	5324
	9	1	54	6			672525	5326
	10	2	72	8	1661		502597	5325
	11	3	55	13	1453	1924	702981	5323
	12	3	95	13	1279	1591	652833	5323
	13	2	87	9	1236		552475	5325

Trial #	Burst Number	Number of Pulses	Pulse Width [usec]	Chirp Width	Pulse 1-to-2 Spacing [usec]	Pulse 2-to-3 Spacing [usec]	Starting Location Within Interval [usec]	Center Frequency [MHz]
24	1	2	76	6	1000		272328	5326
	2	3	79	6	1988	1152	209652	5326
	3	1	58	17			657923	5321
	4	2	62	5	1868		593170	5326
	5	3	100	11	1722	1612	619755	5324
	6	2	84	12	1742		476606	5323
	7	2	66	17	1777		649459	5321
	8	2	53	10	1246		502193	5324
	9	3	66	8	1326	1687	390489	5325
	10	2	60	7	1907		254551	5325
	11	3	62	11	1089	1174	3336	5324
	12	3	72	18	1463	1186	90498	5321
	13	2	94	5	1017		464178	5326
	14	3	87	7	1391	1076	214057	5325
	15	3	60	14	1497	1500	427389	5323
	16	1	93	8			413349	5325

**UL Japan, Inc.**  
**Ise EMC Lab.**

4383-326 Asama-cho, Ise-shi, Mie-ken 516-0021 JAPAN  
Telephone : +81 596 24 8999  
Facsimile : +81 596 24 8124

Trial #	Burst Number	Number of Pulses	Pulse Width [usec]	Chirp Width	Pulse 1-to-2 Spacing [usec]	Pulse 2-to-3 Spacing [usec]	Starting Location Within Interval [usec]	Center Frequency[MHz]
25	1	1	69	19			360	5321
	2	1	54	17			95131	5321
	3	3	82	11	1400	1948	565541	5324
	4	3	68	12	1537	1996	157676	5323
	5	1	77	7			24057	5325
	6	2	63	14	1457		51014	5323
	7	2	63	12	1544		3060	5323
	8	2	89	20	1800		325775	5320
	9	2	63	18	1719		478296	5321
	10	3	86	18	1017	1455	337116	5321
	11	3	69	10	1590	1169	510563	5324
	12	2	88	10	1099		277362	5324
	13	3	88	14	1149	1108	344312	5323
	14	2	91	13	1183		353653	5323
	15	1	84	20			23658	5320
	16	1	54	11			545856	5324
	17	1	93	17			202399	5321
	18	2	99	12	1375		168111	5323
	19	3	65	9	1035	1960	384121	5325
	20	1	75	11			472910	5324

Trial #	Burst Number	Number of Pulses	Pulse Width [usec]	Chirp Width	Pulse 1-to-2 Spacing [usec]	Pulse 2-to-3 Spacing [usec]	Starting Location Within Interval [usec]	Center Frequency[MHz]
26	1	2	53	17	1000		79888	5321
	2	3	95	10	1270	1413	285649	5324
	3	1	81	16			542673	5322
	4	3	79	17	1767	1436	436175	5321
	5	1	76	11			284557	5324
	6	2	78	11	1485		201890	5324
	7	3	75	17	1431	1422	235646	5321
	8	2	70	14	1089		497553	5323
	9	3	74	7	1334	1235	565636	5325
	10	2	74	13	1748		420261	5323
	11	2	64	12	1082		362898	5323
	12	2	61	17	1257		195402	5321
	13	3	71	8	1763	1841	17690	5325
	14	1	85	9			363273	5325
	15	2	87	6	1985		564206	5326
	16	2	73	9	1316		168741	5325
	17	3	67	10	1910	1628	265949	5324
	18	1	95	8			641785	5325

**UL Japan, Inc.**  
**Ise EMC Lab.**

4383-326 Asama-cho, Ise-shi, Mie-ken 516-0021 JAPAN  
Telephone : +81 596 24 8999  
Facsimile : +81 596 24 8124

Trial #	Burst Number	Number of Pulses	Pulse Width [usec]	Chirp Width	Pulse 1-to-2 Spacing [usec]	Pulse 2-to-3 Spacing [usec]	Starting Location Within Interval [usec]	Center Frequency[MHz]
27	1	3	90	12	1605	1537	248099	5323
	2	2	54	17	1712		252196	5321
	3	2	77	7	1788		23587	5325
	4	1	90	18			584186	5321
	5	3	99	6	1538	1703	418817	5326
	6	2	61	16	1453		221822	5322
	7	3	57	16	1156	1150	609775	5322
	8	2	64	18	1808		741847	5321
	9	2	81	13	1420		192644	5323
	10	2	65	5	1155		64590	5326
	11	1	77	5			474689	5326
	12	2	67	10	1751		262759	5324
	13	2	64	14	1949		778381	5323
	14	3	58	7	1586	1997	97259	5325

Trial #	Burst Number	Number of Pulses	Pulse Width [usec]	Chirp Width	Pulse 1-to-2 Spacing [usec]	Pulse 2-to-3 Spacing [usec]	Starting Location Within Interval [usec]	Center Frequency[MHz]
28	1	2	62	7	1000		606646	5325
	2	1	88	11			52072	5324
	3	1	50	8			295698	5325
	4	1	98	14			93975	5323
	5	2	90	9	1071		706232	5325
	6	2	62	19	1168		634929	5321
	7	1	100	20			663935	5320
	8	2	84	17	1668		440997	5321
	9	1	50	12			344911	5323
	10	1	86	13			453693	5323
	11	3	62	5	1350	1032	203095	5326
	12	1	61	19			198900	5321
	13	2	63	11	1532		84149	5324

**UL Japan, Inc.**  
**Ise EMC Lab.**

4383-326 Asama-cho, Ise-shi, Mie-ken 516-0021 JAPAN  
Telephone : +81 596 24 8999  
Facsimile : +81 596 24 8124

Trial #	Burst Number	Number of Pulses	Pulse Width [usec]	Chirp Width	Pulse 1-to-2 Spacing [usec]	Pulse 2-to-3 Spacing [usec]	Starting Location Within Interval [usec]	Center Frequency [MHz]
29	1	1	77	20			53	5320
	2	2	75	13	1042		188103	5323
	3	3	56	10	1557	1359	540489	5324
	4	1	95	19			439663	5321
	5	1	53	10			359144	5324
	6	1	73	6			1039906	5326
	7	3	54	11	1583	1137	811423	5324
	8	2	64	15	1221		318435	5322
	9	3	75	15	1102	1560	151106	5322

Trial #	Burst Number	Number of Pulses	Pulse Width [usec]	Chirp Width	Pulse 1-to-2 Spacing [usec]	Pulse 2-to-3 Spacing [usec]	Starting Location Within Interval [usec]	Center Frequency [MHz]
30	1	1	93	19			327	5321
	2	3	58	9	1514	1120	437688	5325
	3	3	89	11	1096	1662	462273	5324
	4	2	92	7	1273		607354	5325
	5	2	61	6	1210		419675	5326
	6	2	83	18	1854		373443	5321
	7	1	56	18			160524	5321
	8	1	79	14			415547	5323
	9	1	66	20			273586	5320
	10	1	52	19			282032	5321
	11	2	63	17	1641		379818	5321
	12	3	97	12	1042	1828	179722	5323
	13	1	80	14			277390	5323
	14	3	96	5	1640	1619	317944	5326
	15	2	99	20	1611		526463	5320
	16	2	81	15	1808		362420	5322
	17	2	61	7	1998		297232	5325
	18	3	78	14	1878	1892	559478	5323
	19	2	98	5	1429		383594	5326

**UL Japan, Inc.**  
**Ise EMC Lab.**

4383-326 Asama-cho, Ise-shi, Mie-ken 516-0021 JAPAN  
Telephone : +81 596 24 8999  
Facsimile : +81 596 24 8124

## **APPENDIX 2: Test instruments**

### **EMI Test Equipment**

Control No.	Instrument	Manufacturer	Model No	Serial No	Test Item	Calibration Date * Interval(month)
MSA-13	Spectrum Analyzer	Agilent	E4440A	MY46185823	DFS	2015/06/02 * 12
EST-48 *1)	Signal Generator	Agilent	E4438C	MY45090353	DFS	2015/12/30 * 12
COTS-MDFS-01	Signal Studio Software for DFS	Agilent	N7620A-101	5010-7739	DFS	-
COTS-MDFS-02	Radar Generating Software for DFS	Agilent	-	-	DFS	-
MCC-66	Microwave Cable 1G-40GHz	Suhner	SUCOFLEX102	28636/2	DFS	2016/04/18 * 12
MCC-67	Microwave Cable 1G-40GHz	Suhner	SUCOFLEX102	28635/2	DFS	2016/04/18 * 12
MPD-01	PowerDivider DC to 26.5GHz	Agilent	11636B	52258	DFS	2016/03/23 * 12
MAT-60	Attenuator(20dB)	Suhner	6820.19.A	-	DFS	Pre Check
MPSC-06	Power Splitters/Combiners	Pasternack Enterprises	ZFRSC-123-S+	ZFRSC-123-00231	DFS	Pre Check
MAT-58	Attenuator(10dB)	Suhner	6810.19.A	-	DFS	2016/01/18 * 12
MPSC-04	Power Splitters/Combiners	Mini-Circuit	ZFSC-2-10G	0326	DFS	2015/09/18 * 12
MAT-56	Attenuator(10dB)	Suhner	6810.19.A	-	DFS	2016/01/18 * 12
MPSC-07	Power Splitters/Combiners	Pasternack Enterprises	ZFRSC-123-S+	ZFRSC-123-00232	DFS	Pre Check
MCC-94	Microwave Cable 1G-40GHz	Suhner	SUCOFLEX102	30815/2	DFS	-
MCC-100	Microwave Cable 1G-40GHz	Suhner	SUCOFLEX102	30821/2	DFS	-
MOS-14	Thermo-Hygrometer	Custom	CTH-201	1401	DFS	2016/01/21 * 12

**\*1) Signal generator is only used to generate radar test signal, and the wave form is confirmed with spectrum analyzer every time before the test.**

**The expiration date of the calibration is the end of the expired month.**

**All equipment is calibrated with valid calibrations. Each measurement data is traceable to the national or international standards.**

**As for some calibrations performed after the tested dates, those test equipment have been controlled by means of an unbroken chains of calibrations.**

**DFS: Dynamic Frequency Selection**

**UL Japan, Inc.**

**Ise EMC Lab.**

4383-326 Asama-cho, Ise-shi, Mie-ken 516-0021 JAPAN

Telephone : +81 596 24 8999

Facsimile : +81 596 24 8124